

US007855718B2

(12) **United States Patent**
Westerman

(10) **Patent No.:** **US 7,855,718 B2**
(45) **Date of Patent:** **Dec. 21, 2010**

(54) **MULTI-TOUCH INPUT DISCRIMINATION**

(75) Inventor: **Wayne C. Westerman**, San Francisco, CA (US)

(73) Assignee: **Apple Inc.**, Cupertino, CA (US)

(*) Notice: Subject to any disclaimer, the term of this patent is extended or adjusted under 35 U.S.C. 154(b) by 777 days.

| | | |
|-------------|---------|-------------------|
| 4,914,624 A | 4/1990 | Dunthorn |
| 4,954,967 A | 9/1990 | Takahashi |
| 5,073,950 A | 12/1991 | Colbert et al. |
| 5,113,041 A | 5/1992 | Blonder et al. |
| 5,189,732 A | 2/1993 | Kondo |
| 5,252,951 A | 10/1993 | Tannenbaum et al. |
| 5,267,327 A | 11/1993 | Hirayama |
| RE34,476 E | 12/1993 | Norwood |
| 5,276,794 A | 1/1994 | Lamb, Jr. |
| 5,293,430 A | 3/1994 | Shiau et al. |

(Continued)

(21) Appl. No.: **11/619,464**

(22) Filed: **Jan. 3, 2007**

(65) **Prior Publication Data**

US 2008/0158145 A1 Jul. 3, 2008

(51) **Int. Cl.**
G06F 3/041 (2006.01)

(52) **U.S. Cl.** **345/173; 345/156**

(58) **Field of Classification Search** **345/158-173; 382/172, 312, 191, 181, 203, 210**

See application file for complete search history.

(56) **References Cited**

U.S. PATENT DOCUMENTS

| | | |
|-------------|---------|---------------------|
| 4,219,847 A | 8/1980 | Pinkney et al. |
| 4,290,052 A | 9/1981 | Eichelberger et al. |
| 4,293,734 A | 10/1981 | Pepper, Jr. |
| 4,340,911 A | 7/1982 | Kato et al. |
| 4,526,043 A | 7/1985 | Boie et al. |
| 4,550,221 A | 10/1985 | Mabusth |
| 4,618,989 A | 10/1986 | Tsukune et al. |
| 4,678,869 A | 7/1987 | Kable |
| 4,686,332 A | 8/1987 | Greanias et al. |
| 4,736,191 A | 4/1988 | Matzke et al. |
| 4,763,356 A | 8/1988 | Day, Jr. et al. |
| 4,806,709 A | 2/1989 | Evans |
| 4,899,138 A | 2/1990 | Araki et al. |

FOREIGN PATENT DOCUMENTS

EP 0827064 A2 3/1998

(Continued)

OTHER PUBLICATIONS

Harrison, B. et al. "Squeeze Me, Hold Me, Tilt Me! An Exploration of Manipulative User Interfaces," CHI '98, Human Factors in Computing Systems, Conference Proceedings, Los Angeles, CA Apr. 18-23, 1998.

(Continued)

Primary Examiner—Alexander Eisen
Assistant Examiner—Patrick Marinelli

(74) *Attorney, Agent, or Firm*—Morrison & Foerster LLP

(57) **ABSTRACT**

Techniques for identifying and discriminating between different input patterns to a multi-touch touch-screen device are described. By way of example, large objects hovering a short distance from the touch-surface (e.g., a cheek, thigh or chest) may be identified and distinguished from physical contacts to the surface. In addition, rough contacts due to, for example, ears and earlobes, may be similarly identified and distinguished from contacts due to fingers, thumbs, palms and finger clasps.

75 Claims, 5 Drawing Sheets

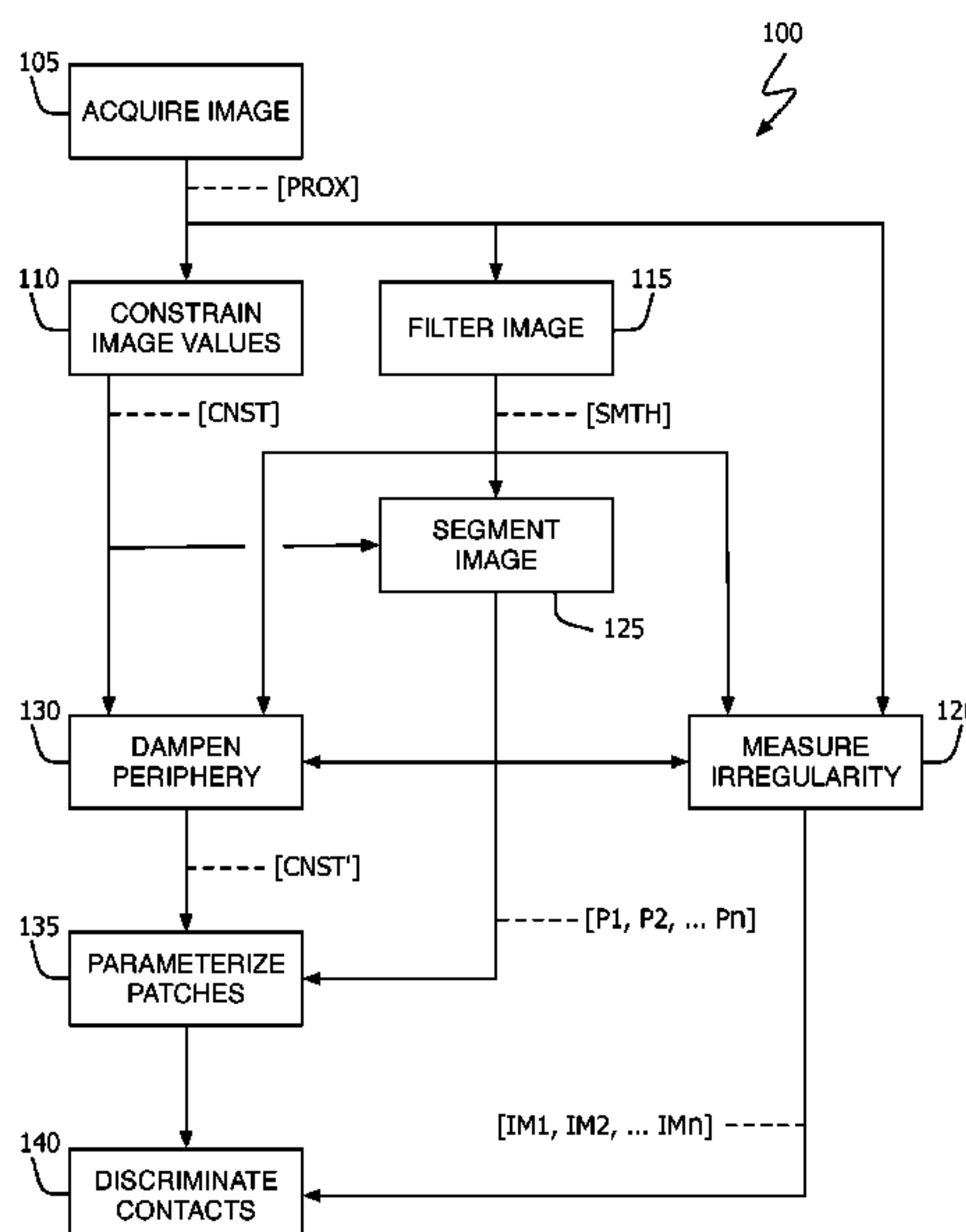

U.S. PATENT DOCUMENTS

5,305,017 A 4/1994 Gerpheide
 5,327,161 A 7/1994 Logan et al.
 5,347,295 A 9/1994 Agulnick et al.
 5,367,453 A 11/1994 Capps et al.
 5,376,946 A 12/1994 Mikan
 5,386,219 A 1/1995 Greanias et al.
 5,432,531 A 7/1995 Calder et al.
 5,446,480 A 8/1995 Yoshida
 5,457,476 A 10/1995 Jenson
 5,463,388 A 10/1995 Boie et al.
 5,479,528 A 12/1995 Speeter
 5,483,261 A 1/1996 Yasutake
 5,488,204 A 1/1996 Mead et al.
 5,491,495 A 2/1996 Ward et al.
 5,543,588 A 8/1996 Bisset et al.
 5,543,590 A 8/1996 Gillespie et al.
 5,543,591 A 8/1996 Gillespie et al.
 5,546,334 A 8/1996 Hsieh et al.
 5,552,787 A 9/1996 Schuler et al.
 5,570,113 A 10/1996 Zetts
 5,583,543 A 12/1996 Takahashi et al.
 5,585,823 A 12/1996 Duchon et al.
 5,594,806 A 1/1997 Colbert
 5,602,943 A * 2/1997 Velho et al. 382/266
 5,603,053 A 2/1997 Gough et al.
 5,638,093 A 6/1997 Takahashi et al.
 5,666,438 A 9/1997 Beernink et al.
 5,673,066 A 9/1997 Toda et al.
 5,734,742 A 3/1998 Asaeda et al.
 5,768,492 A 6/1998 Schumer
 5,793,355 A 8/1998 Youens
 5,805,144 A 9/1998 Scholder et al.
 5,809,166 A 9/1998 Huang et al.
 5,825,352 A 10/1998 Bisset et al.
 5,835,079 A 11/1998 Shieh
 5,838,302 A 11/1998 Kuriyama et al.
 5,856,822 A 1/1999 Du et al.
 5,875,311 A 2/1999 Bertram et al.
 5,880,411 A 3/1999 Gillespie et al.
 5,898,434 A 4/1999 Small et al.
 5,943,043 A 8/1999 Furuhashi et al.
 5,977,950 A 11/1999 Rhyne
 5,982,302 A 11/1999 Ure
 6,008,800 A 12/1999 Pryor
 6,016,355 A 1/2000 Dickinson et al.
 6,029,214 A 2/2000 Dorfman et al.
 6,088,025 A 7/2000 Akamine et al.
 6,118,435 A 9/2000 Fujita et al.
 6,121,960 A 9/2000 Carroll et al.
 6,128,014 A 10/2000 Nakagawa et al.
 6,169,538 B1 1/2001 Nowlan et al.
 6,188,391 B1 2/2001 Seely et al.
 6,262,717 B1 7/2001 Donohue et al.
 6,281,887 B1 8/2001 Wang
 6,310,610 B1 10/2001 Beaton et al.
 6,311,162 B1 10/2001 Reichwein et al.
 6,323,846 B1 11/2001 Westerman et al.
 6,353,433 B1 3/2002 Schumer
 6,504,530 B1 1/2003 Wilson et al.
 6,518,957 B1 2/2003 Lehtinen et al.
 6,552,719 B2 4/2003 Lui et al.
 6,610,936 B2 8/2003 Gillespie et al.
 6,633,683 B1 * 10/2003 Dinh et al. 382/260
 6,657,614 B1 12/2003 Ito et al.
 6,664,982 B1 12/2003 Bi
 6,690,387 B2 2/2004 Zimmerman et al.
 6,727,891 B2 4/2004 Moriya et al.
 6,788,815 B2 9/2004 Lui et al.
 6,924,790 B1 8/2005 Bi
 7,015,894 B2 3/2006 Morohoshi
 7,030,860 B1 4/2006 Hsu et al.

7,030,862 B2 4/2006 Nozaki
 7,053,886 B2 5/2006 Shin
 7,184,064 B2 2/2007 Zimmerman et al.
 7,274,353 B2 9/2007 Chiu et al.
 7,283,126 B2 10/2007 Leung
 7,292,229 B2 11/2007 Morag et al.
 7,339,580 B2 3/2008 Westerman et al.
 7,444,163 B2 10/2008 Ban et al.
 7,633,076 B2 12/2009 Huppi et al.
 2002/0080123 A1 6/2002 Kennedy et al.
 2002/0191029 A1 12/2002 Gillespie et al.
 2003/0117380 A1 6/2003 Kanzaki
 2003/0161517 A1 * 8/2003 Vuylsteke 382/128
 2003/0214488 A1 11/2003 Katoh
 2004/0119700 A1 6/2004 Ichikawa
 2005/0052427 A1 3/2005 Wu et al.
 2005/0104867 A1 * 5/2005 Westerman et al. 345/173
 2005/0226505 A1 * 10/2005 Wilson 382/180
 2006/0026521 A1 2/2006 Hotelling et al.
 2006/0044259 A1 3/2006 Hotelling et al.
 2006/0044280 A1 3/2006 Huddleston et al.
 2006/0097991 A1 5/2006 Hotelling et al.
 2006/0161871 A1 7/2006 Hotelling et al.
 2006/0197750 A1 9/2006 Kerr et al.
 2006/0197753 A1 9/2006 Hotelling
 2006/0232567 A1 10/2006 Westerman et al.
 2007/0083372 A1 4/2007 Cho et al.
 2008/0012835 A1 * 1/2008 Rimon et al. 345/173
 2008/0158145 A1 7/2008 Westerman

FOREIGN PATENT DOCUMENTS

GB 2 139 762 A 11/1984
 JP 62-030888 A 2/1987
 JP 2000-163031 A 6/2000
 JP 2000-300543 A 10/2000
 JP 2002-342033 A 11/2002
 JP 2004-178547 A 6/2004
 KR 100664964 B1 12/2006
 WO WO-97/18547 A1 5/1997
 WO WO-99/38149 A1 7/1999
 WO WO 2005/114369 A2 12/2005
 WO WO 2006/020305 A2 2/2006
 WO WO 2006/074289 A2 7/2006
 WO WO 2006/133018 A2 12/2006
 WO WO-2008/085404 A2 7/2008
 WO WO-2008/085785 A2 10/2008
 WO WO-2008/085785 A3 10/2008

OTHER PUBLICATIONS

Rekimoto, Jun, "SmartSkin: An Infrastructure for Freehand Manipulation on Interactive Surfaces," CHI 2002, Human Factors in Computing Systems, Conference Proceedings, Minneapolis, MN, Apr. 20-25, 2002.
 International Search Report mailed Dec. 4, 2008, for PCT Application No. PCT/2007/026145, filed Dec. 21, 2007, nine pages.
 Gonzalez, Rafael C. et al., "Digital Image Processing (passage)", Prentice Hall, Upper Saddle River, New Jersey, Jan. 1, 2002.
 Synaptics Pilotfish, "Onyx", http://www.web.archive.org/web/20061125030217/http://www.synaptics.com/products/pdf/onyx_concept.pdf, Nov. 25, 2006.
 International Search Report mailed Jul. 29, 2008, for PCT Application No. PCT/2007/089164, filed Dec. 28, 2007, three pages.
 Invitation to Pay Additional Fees mailed Jul. 16, 2008, for PCT Application No. PCT/US07/26145, filed Dec. 21, 2007, six pages.
 Apte, A. et al. (Nov. 1993). "Recognizing Multistroke Geometric Shapes: An Experimental Evaluation," *Association for Computing Machinery UIST '93*, Atlanta, GA, Nov. 3-5, 1993, 121-128.
 Buxton, W. et al. (Jul. 1985). "Issues and Techniques in Touch-Sensitive Tablet Input," *Association for Computing Machinery SIG-GRAPH '85*, San Francisco, CA, Jul. 22-26, 1985, 19(3):215-224.

- Cirque Corporation. (1994). GripePoint® Portable Touch Surface Round Mouse Post PS/2 Version User's Guide, Guide Version 1.0, 16 pages.
- Davies, E.R. (Aug. 1987). "Lateral Histograms for Efficient Object Location: Speed Versus Ambiguity," *Pattern Recognition Letters* 6(3):189-198.
- Davies, E.R. (1990). *Machine Vision: Theory, Algorithms, Practicalities*, Academic Press, Inc.: San Diego, CA, 575 pages.
- Dvorak, J. (Apr. 1992). "Whatever Happened to the Gavilan Mobile Computer?," *Computer Shopper* 12(4):668, Dialog® search result, nine pages.
- Elo Touchsystems, Inc. (1993). SmartSet™ Touchscreen Controller Family Technical Reference Manual, Manual Version 1.0, 139 pages.
- Elographics, Inc. (1988). E271-140 AccuTouch® Serial Touchscreen Controller, User's Manual Version 2.0, 24 pages.
- Elographics, Inc. (1989). "All the Building Blocks You Need to Quickly Develop Touchscreen Applications," eight pages.
- Elographics, Inc. (1989). "Application Development Tools," four pages.
- Elographics, Inc. (1990). ELODEV™ Touchscreen Driver Program Version 1.4, Installation Guide and Programmer's Reference Manual, Manual Version 2.0c, 119 pages.
- Elographics, Inc. (1990). MonitorMouse™ and MonitorMouse for Windows™ 3.0, Version 1.2, User's Guide, Manual Version 1.2, 33 pages.
- Elographics, Inc. (1993). "In Touch with Excellence," seven pages.
- Elographics, Inc. (1993). TouchBack™ Version 1.2 Programmer's Reference Manual, Manual Version 2.0a, 70 pages.
- Fearing, R.S. (1988). "Tactile Sensing, Perception and Shape Interpretation," A Dissertation Submitted to the Department of Electrical Engineering and the Committee on Graduate Studies of Stanford University in Partial Fulfillment of the Requirements for the Degree of Doctor of Philosophy, presented Dec. 1987, 160 pages.
- Fearing, R.S. (Jun. 1990). "Tactile Sensing Mechanisms," *Robotics Research* 9(3):3-23.
- Gavilan Computer Corporation. (Jan. 23, 1984). Gavilan™ Mobile Computer: MS-DOS User's Guide, Part No: 620-0010-02, 276 pages.
- Kirk, D.E. (1970). "The Method of Steepest Descent," Chapter 6.2 in *Optimal Control Theory: An introduction*, Prentice-Hall, Inc.: Englewood Cliffs, NJ, pp. 331-343.
- Lee, S. (Oct. 1984). "A Fast Multiple-Touch-Sensitive Input Device," A Thesis Submitted in Conformity with the Requirements for the Degree of Master of Applied Science in the Department of Electrical Engineering, University of Toronto, 115 pages.
- Lee, S.K. et al. (Apr. 1985). "A Multi-Touch Three Dimensional Touch-Sensitive Tablet," *Proceedings of CHI: ACM Conference on Human Factors in Computing Systems*, pp. 21-25.
- Logitech, Fremont, Inc. (Aug. 2, 1998). P2.1 Touchpad, Firmware Engineering Specification FWS-761588-0000, Revision A, 25 pages.
- Logitech, Inc. (Jun. 24, 1997). TP3™ -Standard Touch Pad Product Specification, Document ID: PS-761311-0000-USA, 27 pages.
- Mehta, N. (Oct. 1982). "A Flexible Human Machine Interface," A Thesis Submitted in Conformity with the Requirements for the Degree of Master of Applied Science in the University of Toronto, 87 pages.
- Microtouch Systems, Inc. (1993). TouchWare for DOS, Windows and NT, User's Guide, Revision 3.0 #19-207, 33 pages.
- Microtouch Systems, Inc. (1993). Windows Touch Driver, User's Guide, Revision 2.0 #9006601, 26 pages.
- Ogawa, H. (1979). "Preprocessing for Chinese Character Recognition and Global Classification of Handwritten Chinese Characters," *Pattern Recognition*, 11(1):1-7.
- Rubine, D. (Sep. 1988). "The VideoHarp," *Proceedings of the 14th International Computer Music Conference*, Cologne, FR, Sep. 20-25, 1988, 11 pages.
- Rubine, D. (Jul. 1991). "Specifying Gestures by Example," *Computer Graphics* 25(4):329-337.
- Rubine, D.H. (Dec. 1991). "The Automatic Recognition of Gestures," CMU-CS-91-202, Submitted in Partial Fulfillment of the Requirements of the Degree of Doctor of Philosophy in Computer Science at Carnegie Mellon University, 285 pages.
- Rubine, D.H. (May 1992). "Combining Gestures and Direct Manipulation," CHI '92, pp. 659-660.
- Sensor Frame Corporation. (May 8, 1990). "The Sensor Frame Graphic Manipulator Final Report," Sensor Frame Corporation: NASA-CR-194243, 28 pages.
- Siegel, D.M. et al. (1987). "Performance Analysis of a Tactile Sensor," IEEE, pp. 1493-1499.
- Stauffer, R.N., ed. (Jun. 1983). "Progress in Tactile Sensor Development," *Robotics Today* pp. 43-49.
- Sugiyama, S. et al. (Mar. 1990). "Tactile Image Detection Using a 1K-Element Silicon Pressure Sensor Array," *Sensors and Actuators*, A22(Nos. 1-2):397-400.
- Summagraphics Corporation. (1987). Four-Button Cursor for the Summagraphics® Bit Pad® Plus, one page.
- Summagraphics Corporation. (Sep. 1989). CR™ 1212 Graphics Tablet Technical Reference, Publication #84-2001-002, 53 pages.
- Synaptics, Inc. (1999). The TouchPad: A Revolutionary Human Interface Device, four pages.
- Westerman, W. (Spring 1999). "Hand Tracking, Finger Identification, and Chordic Manipulation on a Multi-Touch Surface," A Dissertation Submitted to the Faculty of the University of Delaware in Partial Fulfillment of the Requirements for the Degree of Doctor of Philosophy in Electrical Engineering, 364 pages.
- International Preliminary Report on Patentability mailed Jul. 7, 2009, for PCT Application No. PCT/2007/026145, filed Dec. 21, 2007, 13 pages.
- International Preliminary Report on Patentability Response mailed Sep. 23, 2010, in EP Patent Application No. 07863193.4, 15 pages.
- Notice of Allowance mailed Jul. 9, 2010, for U.S. Appl. No. 11/756,211, filed May 31, 2007, 13 pages.

* cited by examiner

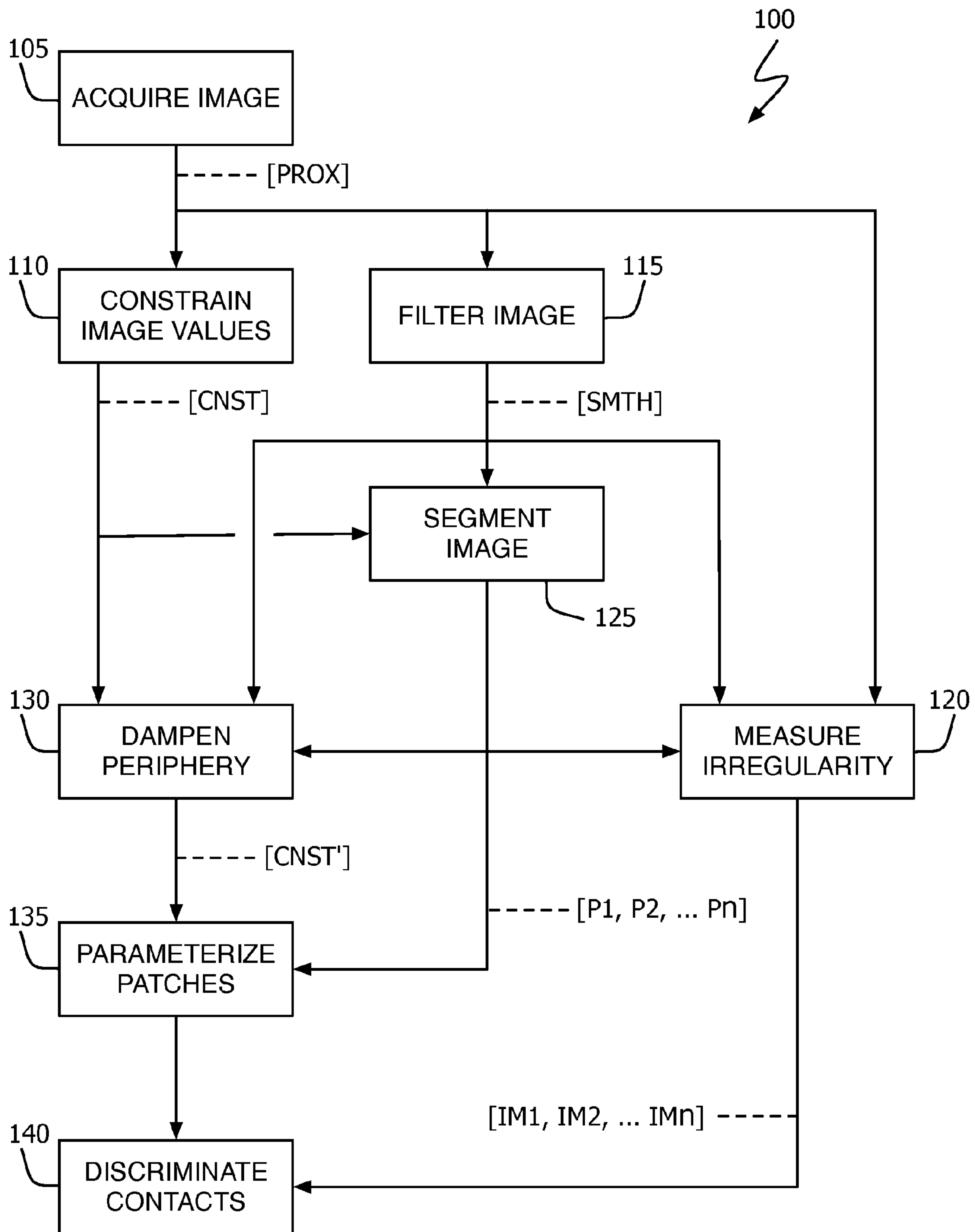

FIG. 1

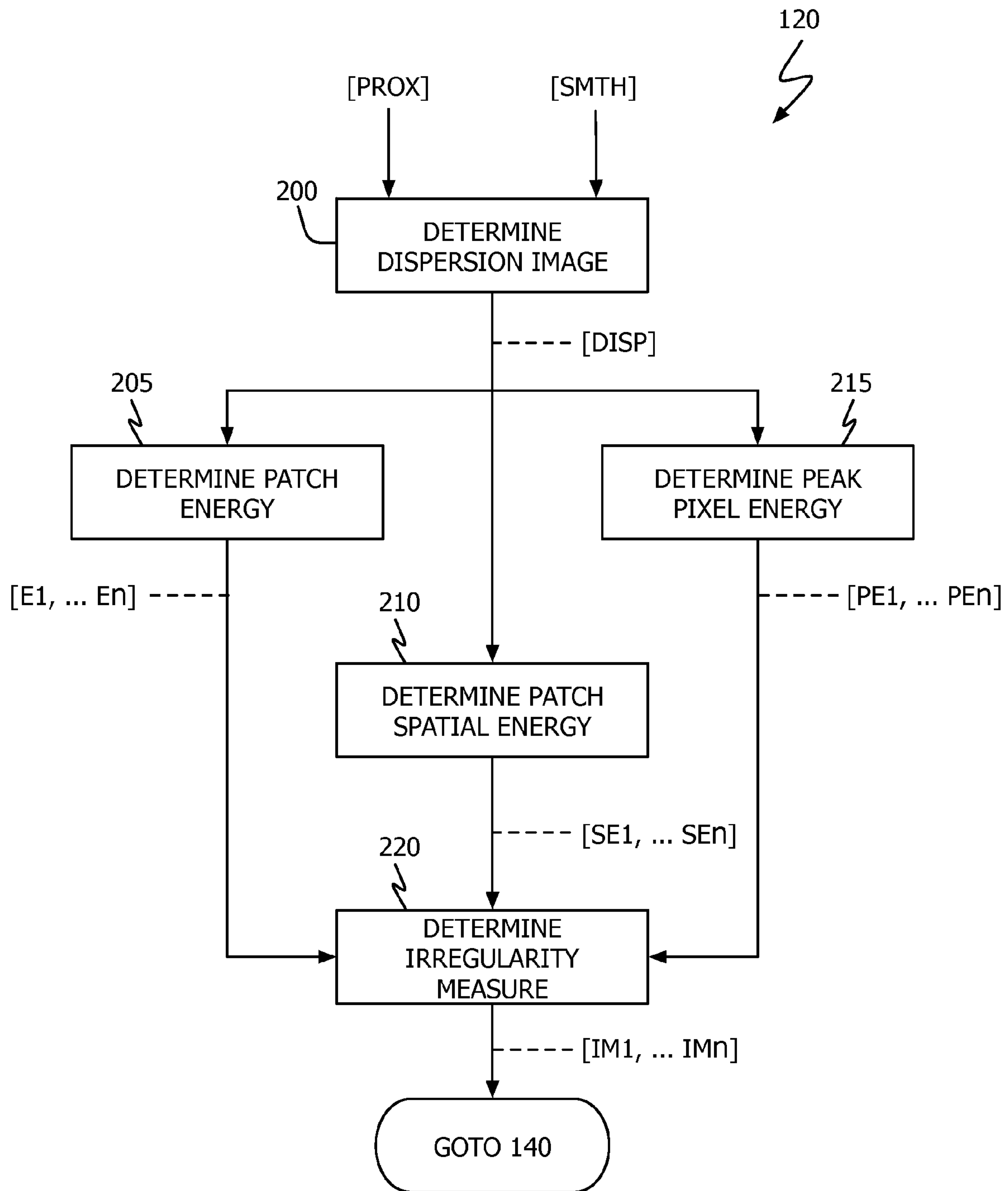

FIG. 2

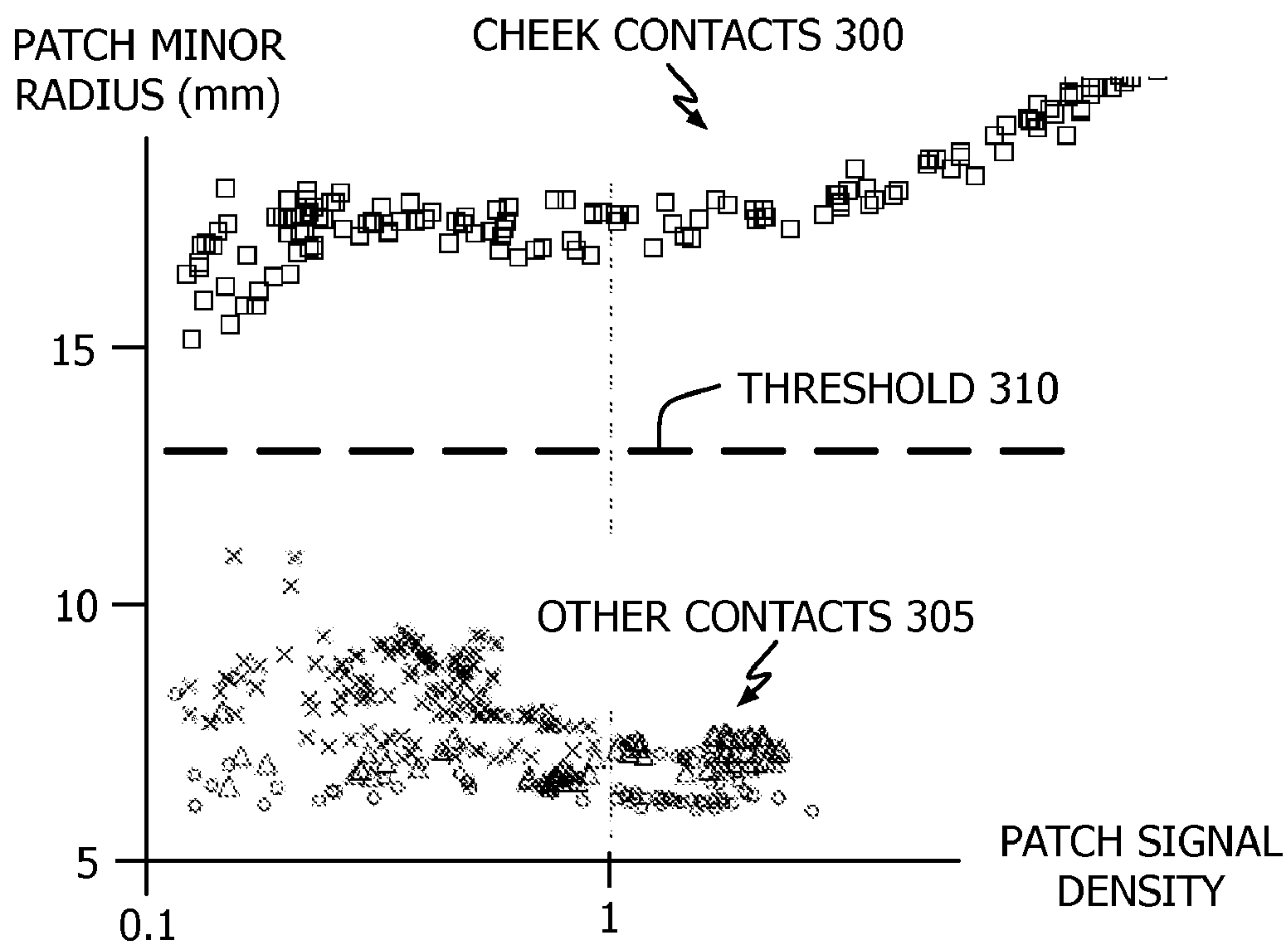

FIG. 3

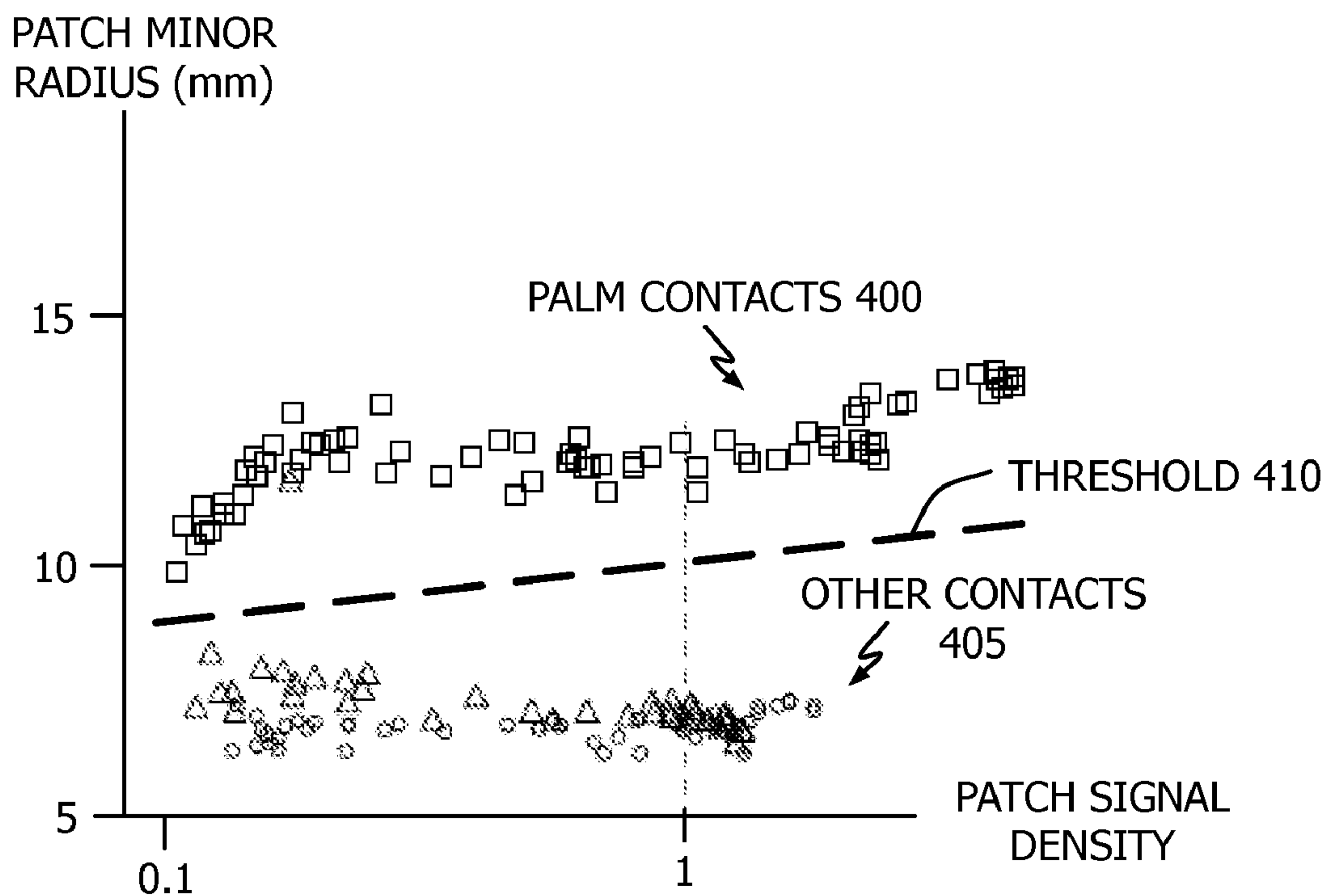

FIG. 4

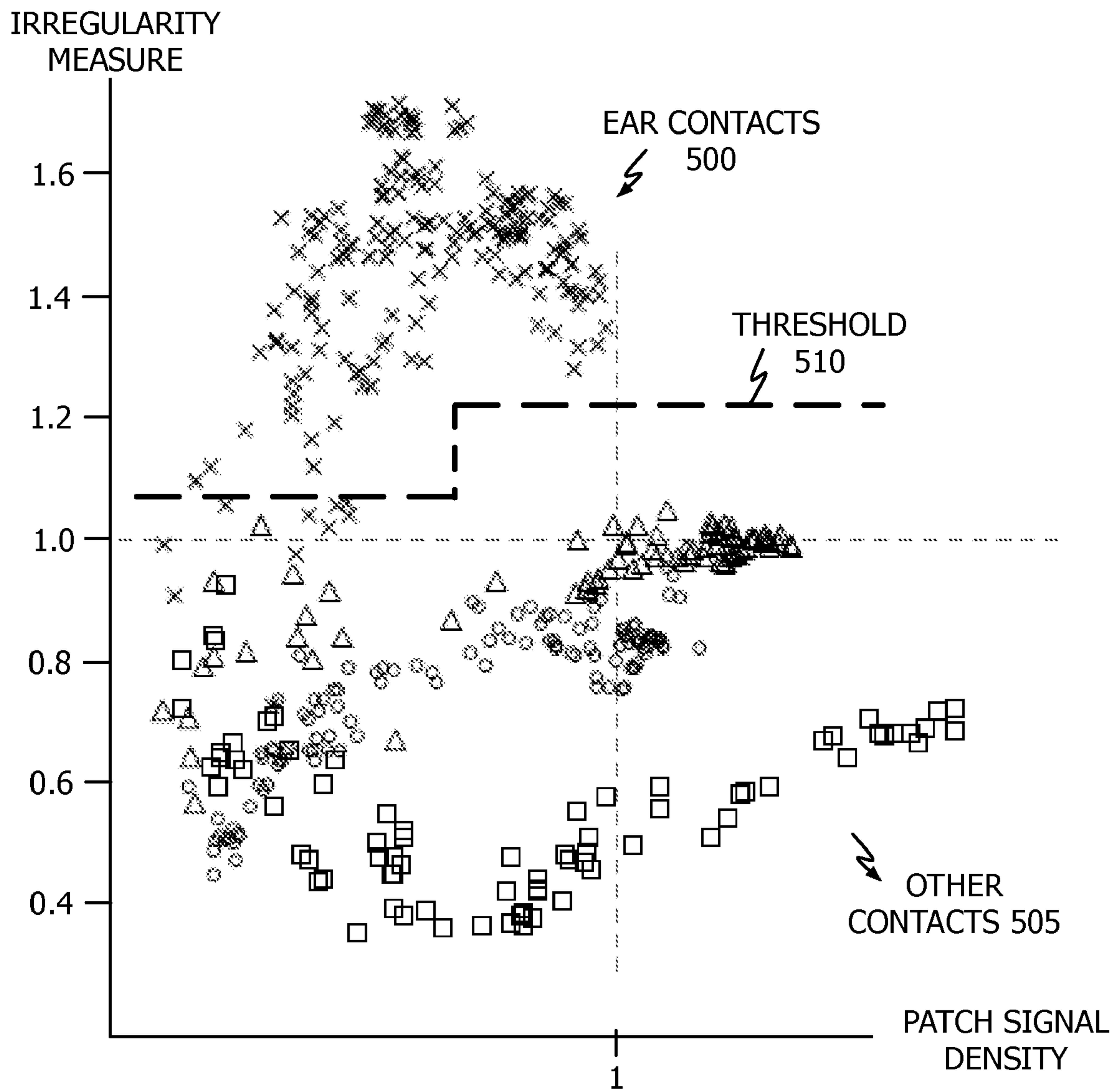

FIG. 5

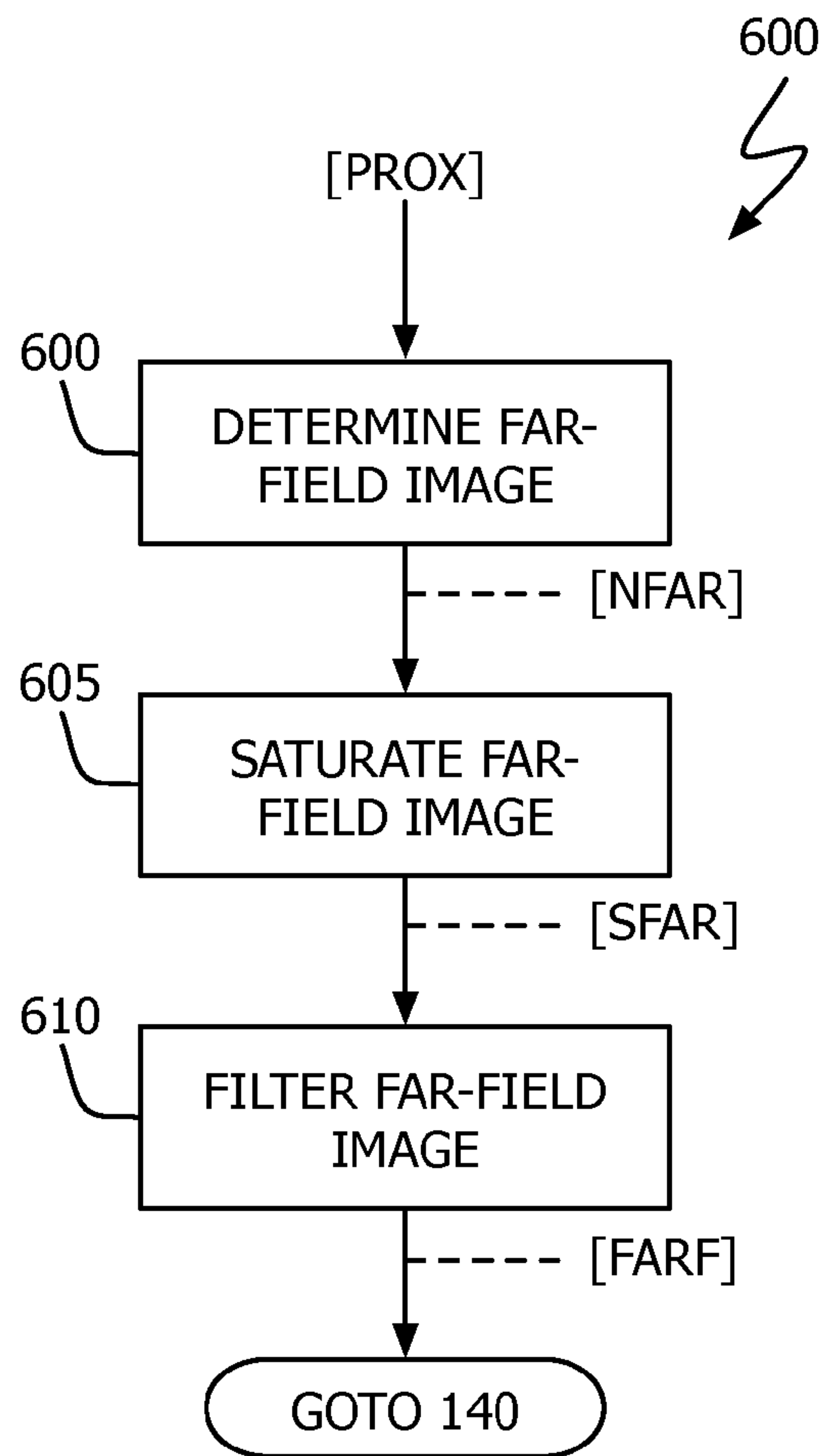

FIG. 6

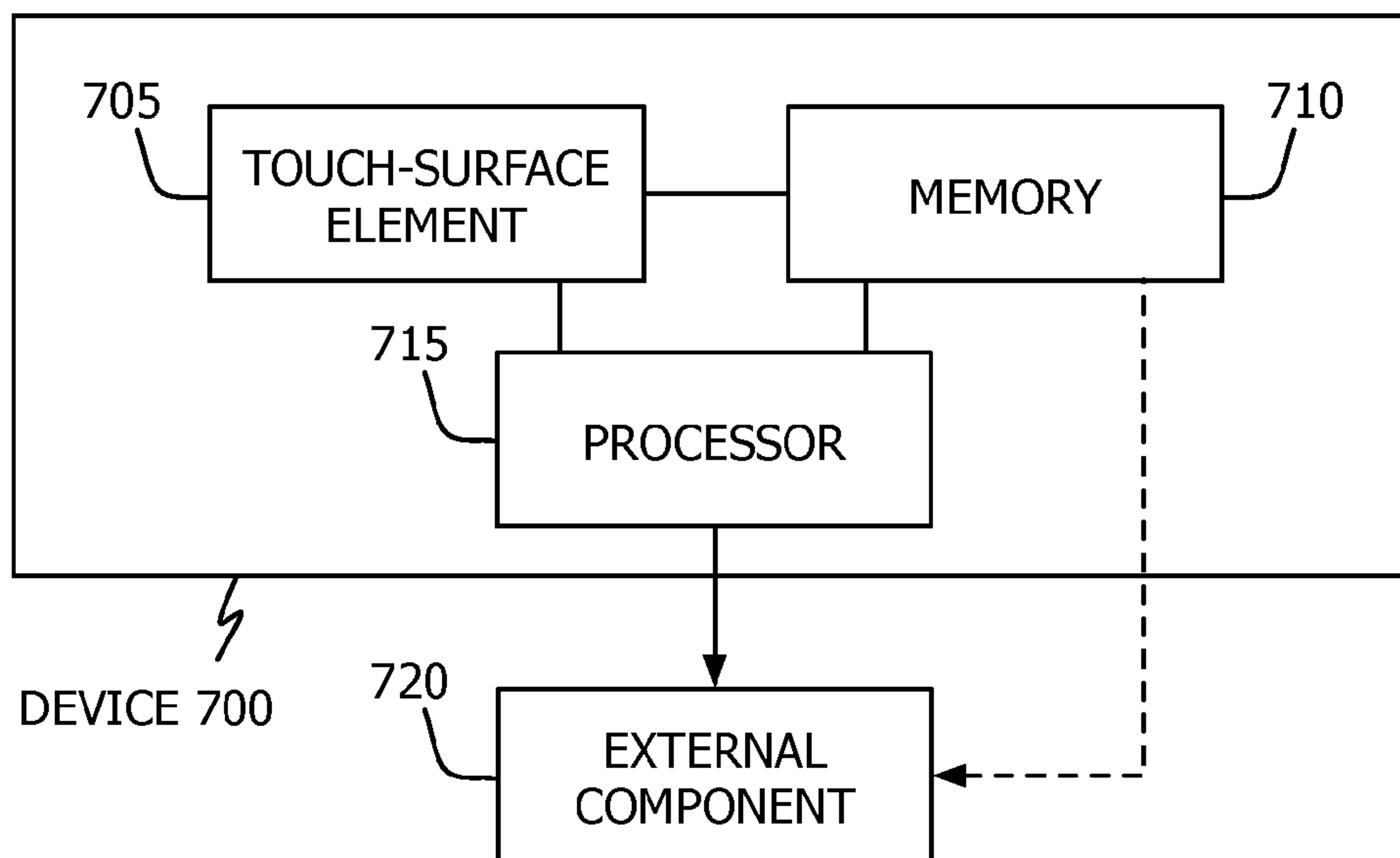

FIG. 7

MULTI-TOUCH INPUT DISCRIMINATION

BACKGROUND

The subject matter described and claimed herein is related to the subject matter described in U.S. Pat. No. 6,323,846, issued 27 Nov. 2001, entitled "Method and Apparatus for Integrating Manual Input" by W. Westerman and J. Elias and to application Ser. No. 11/619,595, filed 3 Jan. 2007, entitled "Multi-Event Input System" by S. Herz, R. Yopez and W. Westerman, both of which are hereby incorporated by reference.

The invention relates generally to data input methods and devices for electronic equipment and, more particularly, to methods and devices for discriminating between various inputs to a multi-touch touch-surface input device.

There currently exist many types of input devices for performing operations with an electronic system. These operations often correspond to moving a cursor and/or making selections on a display screen. Illustrative electronic systems include tablet, notebook, desktop and server computer systems, personal digital assistants, audio and video control systems, portable music and video players and mobile and satellite telephones. The use of touch pad and touch screen systems (collectively "touch-surfaces") has become increasingly popular in these types of electronic systems because of their ease of use and versatility of operation.

One particular type of touch-surface is the touch screen. Touch screens typically include a touch panel, a controller and a software driver. The touch panel is characteristically an optically clear panel with a touch sensitive surface that is positioned in front of a display screen so that the touch sensitive surface is coextensive with a specified portion of the display screen's viewable area (most often, the entire display area). The touch panel registers touch events and sends signals indicative of these events to the controller. The controller processes these signals and sends the resulting data to the software driver. The software driver, in turn, translates the resulting data into events recognizable by the electronic system (e.g., finger movements and selections).

Unlike earlier input devices, touch-surfaces now becoming available are capable of simultaneously detecting multiple objects as they approach and/or contact the touch-surface, and detecting object shapes in much more detail. To take advantage of this capability, it is necessary to measure, identify and distinguish between the many kinds of objects that may approach or contact such touch-surfaces simultaneously. Prior art touch-surface systems (including their supporting software and/or circuitry) do not provide a robust ability to do this. Thus, it would be beneficial to provide methods and devices that identify and discriminate multiple simultaneous hover or touch events such as, for example, two or more closely grouped fingers, palm heels from one or more fingers, fingers from thumbs, and fingers from ears and cheeks.

SUMMARY

In one embodiment the invention provides a method to discriminate input sources to a touch-surface device. The method includes obtaining a proximity image, segmenting the proximity image to identify a plurality of patches, determining the minor axis radius for each of the plurality of patches, identifying one of the patches as being associated with a large object (e.g., a cheek or leg surface) if the minor axis radius value of the patch is above a first specified threshold, and controlling the operation of a touch-surface device based on the identified large object. In one embodiment,

device control is manifest through changing the device's operating mode (e.g., off to on). In another embodiment, device control is manifest through ignoring the identified large object so that it does not cause a change in the device's operating state.

In another embodiment, the invention is directed to identifying and distinguishing various inputs to a multi-touch touch-surface. Illustrative inputs result from sources such as ears, cheeks, legs, chests, fingers, thumbs and palms.

Illustrative touch-surface devices include, but are not limited to, tablet computer systems, notebook computer systems, portable music and video systems and mobile telephones. Methods in accordance with any of the described methodologies may be stored in any media that is readable and executable by a programmable control device such as, for example, by a general purpose computer processor.

BRIEF DESCRIPTION OF THE DRAWINGS

FIG. 1 shows, in flowchart form, a multi-touch processing methodology in accordance with one embodiment of the invention.

FIG. 2 shows, in flowchart form, a patch irregularity calculation in accordance with one embodiment of the invention.

FIG. 3 shows a plot of empirically determined data illustrating patch minor radii's ability to discriminate between large touch-surface contacts (cheeks, for example) and other touch-surface contacts (fingertips and thumbs, for example).

FIG. 4 shows a plot of empirically determined data illustrating patch minor radii's ability to discriminate between palm contacts and other touch-surface contacts (e.g., fingertips and thumbs).

FIG. 5 shows a plot of empirically determined data illustrating a patch irregularity measure's ability to discriminate between ear contacts and other touch-surface contacts (e.g., fingertips, thumbs and cheeks).

FIG. 6 shows, in flowchart form, far-field operations in accordance with one embodiment of the invention.

FIG. 7 shows, in block diagram form, a touch-surface device in accordance with one embodiment of the invention.

DETAILED DESCRIPTION

Methods and devices to detect and discriminate between multiple simultaneous close approaches or touches to a touch-surface are described. The following embodiments are presented to enable any person skilled in the art to make and use the invention as claimed and are provided in the context of mutual capacitance touch-surface devices. Variations using other types of touch-surfaces such as force or optical sensing touch-surfaces will be readily apparent to those skilled in the art. Accordingly, the claims appended hereto are not intended to be limited by the disclosed embodiments, but are to be accorded their widest scope consistent with the principles and features disclosed herein.

As previously noted, recent touch-surface input devices are capable of simultaneously detecting multiple objects as they approach and/or contact the touch-surface. For a hand-held multi-touch touch-surface device that may be put into a pocket, purse, or held against the head (e.g., portable music player, portable video player, personal digital assistant or mobile phone), detecting when the device is being clasped on the way into or out of the pocket, against the body, or against the head is very useful for: input rejection (ensuring that touch-surface input signals generated as a result of these actions are not mistaken for normal finger/stylus touches); operational mode transitions (e.g., dimming the device's

backlight, putting the device to sleep and waking the device from a low-power state); and, for mobile telephones, answering calls (e.g., when the device is brought near, but not necessarily touching the head) and/or terminating calls (e.g., when the unit is placed into a pocket or purse).

Each sensing element (aka “pixel”) in a two dimensional array of sensing elements (i.e., a touch-surface) generates an output signal indicative of the electric field disturbance (for capacitance sensors), force (for pressure sensors) or optical coupling (for optical sensors) at the sensor element. The ensemble of pixel values represents a “proximity image.” As described herein, various embodiments of the invention address the ability to detect and discriminate between touch-surface signals (represented as a proximity image) resulting from, for example, the types of actions identified in the preceding paragraph.

Referring to FIG. 1, multi-touch processing methodology **100** in accordance with one embodiment of the invention begins with the acquisition of proximity image data (block **105**). Because the acquired data is usually a superposition of information (indicating an object close to or in contact with the touch-surface) fixed offsets (due to circuitry baselines) and noise (e.g., radio frequency interference), an initial adjustment to acquired pixel data may be made to compensate for sensor element baseline activity. For example, on multi-touch device initialization and/or when being brought out of a low-power mode (e.g., sleep), one or more images may be captured. By assuming these initial images include no surface contacts, they may be used to provide the sensor’s baseline. Averaging over multiple sequential images (using, for example, infinite or finite impulse response filters) has been found to provide more accurate baseline values. These baseline values may be subtracted from each subsequently captured image to provide a proximity image for use in ongoing image processing steps. In another embodiment, baseline pixel values may be slowly adjusted over time to compensate for temperature or static charge. In addition, the initial baseline values may need to be adjusted if, in fact, touch-surface contacts were present at start-up. In yet another embodiment, a plurality of image samples may be acquired each at a different sensor element driving frequency. For each pixel in these images, the mean or median of subtracted samples (i.e., between the captured baseline and information images) may be combined to create an initial (typically signed) image in accordance with block **105**. For noise that occasionally generates large outlier pixel values (“spiky” noise), other rank-order filters may be useful. As noted in FIG. 1, proximity image data resulting from operations in accordance with block **105** is denoted [PROX].

Next, [PROX] image data feeds other processing blocks that may operate sequentially or in parallel with one another (blocks **110**, **115** and **120**). It has been found that filtering or smoothing a proximity image (block **115**) prior to segmentation (block **125**) reduces the number of spurious peaks and thus helps reduce over segmentation. In one embodiment of block **115**, each pixel value may be averaged with its nearest neighbor pixels in accordance with a discrete diffusion operation. If this approach is employed, it has been found beneficial to insert a “border” around the captured image so that there is a value with which to average the pixels at the edge of the captured image. For example, a one (1) pixel border may be added to the [PROX] image—where each “border” pixel is assigned a value corresponding to the image’s “background” (e.g., zero). In another embodiment, both temporal (e.g., obtaining multiple images over a period of time) and spatial (e.g., averaging neighbor pixels) smoothing operations may be used. Multiple smoothing operations may be beneficial if

the captured pixel data is particularly noisy. As noted in FIG. 1, image data resulting from operations in accordance with block **115** is denoted [SMTH].

While [PROX] image pixel values are typically zero or positive in response to an object contacting the touch-surface (aka, a “grounded” object), background noise or objects close to but not touching the touch-surface (aka “ungrounded” objects) may produce an image some of whose pixel values are negative. Background noise may be static or vary with circuit temperature, touch-surface moisture, or other factors. Noisy, negative pixels can cause excessive jitter in centroid and other patch measurements (see discussion below regarding block [135]). To compensate for this, [PROX] image pixel values may be confined to a desired, typically positive, range (block **110**). Subtracting the noise threshold helps reduce centroid jitter induced from pixels that wander around (above and below) the noise threshold in successive image frames. As noted in FIG. 1, image data resulting from operations in accordance with block **110** is denoted [CNST]. In one embodiment, all pixel whose values are less than a background noise threshold are set to zero. In another embodiment, a noise-threshold is subtracted from each pixel value and the result is forced to be non-negative, as shown in Table 1.

TABLE 1

| Illustrative Pixel Constraint Technique | |
|---|-------------------------------------|
| On a pixel-by-pixel basis: | |
| If [PROX] < (Noise Threshold) | [CNST] = (Background Value) |
| Else | [CNST] = [PROX] – (Noise Threshold) |

In one embodiment, the noise-threshold value is set to between 1 and 3 standard deviations of the noise measured at each pixel and the background-value is set to zero. One skilled in the art will recognize that other values are possible and that the precise choice of values depends, inter alia, on the type of sensor element used, the actual or expected level of pixel noise and the multi-touch device’s operational environment. For example, the noise threshold may be set to a specified expected value on a per-pixel basis or a single value may be used for all pixels in an image. In addition, pixel noise values may be allowed to vary over time such that thermal and environmental effects on sensor element noise may be compensated for.

Touch-surface contacts typically show up as grouped collections of “active” pixel values, where each region of fleshy contact (e.g. finger, palm, cheek, ear or thigh) is represented by a roughly elliptical patch of pixels.

By analyzing an image’s topography, image segmentation operations can identify distinct pixel patches that correspond to touch-surface contacts (block **125**). In one embodiment, bottom-up, ridge-hiking algorithms may be used to group pixels that are part of the same watershed around each peak pixel—each watershed group or pixel patch corresponds to a touch-surface contact. In another embodiment, top-down search algorithms may be used to identify pixel patches surrounding each peak pixel, starting from the peak, searching outward and stopping at valleys. As part of the image segmentation process, one-dimensional patches may be culled from the identified patches in that they generally result from isolated noise spikes or failure of an entire row or column of sensor elements and/or associated circuitry. In addition, because large contacts such as palms and elongated thumbs

5

may produce multiple peaks in a proximity image (due to noise or non-uniform signal saturation, for example), multiple peaks in the image can grow into multiple, split patches. To account for this phenomenon, multiple detected patches may be merged to produce a reduced number of patches for further processing. Heuristic or empirically determined rules may, for example, be applied to accomplish this. For example, two separately identified patches may be merged when the saddle point along their shared border is not “very deep”—e.g., when the saddle magnitude is more than 60% to 80% of the two patches’ peak pixel values. As noted in FIG. 1, identified patches resulting from operations in accordance with block 125 are denoted [P1, P2, . . . Pn].

Analysis shows that noise from pixels on the periphery of a patch, far from the center or peak pixel, can cause more jitter in calculated centroid (center-of-‘mass’) measurements than the same amount of noise from central pixels. This phenomenon applies to other statistically-fitted patch parameters such as major/minor radii and orientation as well. This jitter can be a particularly serious problem for the smooth tracking of hovering objects because hovering objects do not generally induce strong central pixels, leaving the peripheral pixels with even greater influence on the centroid measurement. However, completely leaving these peripheral pixels out of a patches’ centroid calculations would discard potentially useful information about the position, size, and shape of the patch. It is further noted that performing patch parameterization on diffused images may reduce noise from peripheral pixels, but standard spatial filtering processes also cause swelling and distortion of patch shape, cause adjacent patches to spread into one another and other effects that bias centroid and ellipse radii measurements in particular. Thus, a technique is needed that minimizes the amount of noise from patch periphery pixels without strongly distorting patch shape and ensuing measurements.

In accordance with one embodiment of the invention, therefore, patch peripheral pixel values may be selectively reduced, down-scaled or dampened (block 130). Generally, patch centroid determination may be improved by selectively down-scaling patch peripheral pixels that are fairly weak and whose neighbors are very weak. More specifically, in one embodiment calibrated image pixel values (e.g., in [CNST]) whose corresponding smoothed value (e.g., in [SMTH]) falls within a specified range defined by a lower-limit and an upper-limit are reduced in proportion to where the smoothed value falls within that range. Lower and upper limits are chosen empirically so that only those pixel values that are relatively weak (compared to patch peak values and background noise) are manipulated. It has been found that: if the lower-limit is set too low, the patch will “bloom” from background pixels that happen to have positive noise; if the lower-limit is set too high, the patches’ centroid position will have a spatially periodic bias toward sensor element centers (e.g., capacitive electrode plate centers); if the upper-limit is not sufficiently higher than the lower-limit, periphery dampening will not provide any significant centroid jitter reduction benefits; and if the upper-limit is too high, all patch pixels besides the patches’ peak pixel will be affected, again biasing determination of the patches’ centroid toward sensor element centers. In accordance with one embodiment of the invention, the lower-limit is set, on a pixel-by-pixel basis, to approximately twice the background noise standard deviation and the upper-limit is set to approximately four times the background noise standard deviation (with the background value typically being zero). In another embodiment, the lower-limit is set to a value indicative of the “average” or “expected” noise across all pixels in the proximity image. In some embodiments, the

6

noise value may change dynamically to reflect changing operational conditions (see comments above). As noted in FIG. 1, an image whose peripheral patch pixels have been dampened in accordance with block 130 is denoted [CNST’]. In one embodiment, peripheral patch pixels are dampened as shown in Table 2.

TABLE 2

| Illustrative Peripheral Patch Pixel Dampening | |
|---|------------------------------|
| For each pixel in a patch: | |
| If [SMTH] < (Lower Limit) | [CNST’] = (Background Value) |
| Else If [SMTH] > (Upper Limit) | [CNST’] = [CNST] |
| Else | |
| $[CNST'] = \frac{[SMTH] - \text{Lower Limit}}{\text{Upper Limit} - \text{Lower Limit}} \times [CNST]$ | |

Patch peripheral pixel dampening such as described above is equally applicable to touch-surfaces that provide one-dimensional proximity images. For example, projection scan touch-surfaces provide an output value (or signal) for each row and column of sensor elements in a touch-surface. In these types of touch-surfaces, a “patch” comprises a plurality of values, where each value represents a row or column measurement. The values at the ends of these patches (i.e., the peripheral values) may benefit from noise dampening as described here.

For certain touch-surface input devices such as a telephone, the ear and earlobe may contact the touch-surface sooner or more often than the cheek during calls. Unfortunately, earlobe patches can be very close in size to finger and thumb patches—but should, nevertheless, not cause spurious finger-button activations during a call. In accordance with one embodiment of the invention, a measurement of patch irregularity is defined that does not look for any specific ear (patch) shape, but rather indicates a general roughness, non-roundness or folds in the pixel patch (block 120). That is, if a patches’ irregularity measure is above a specified threshold, the contact is identified as an irregular object (e.g., not a cheek, finger or palm), otherwise the patch is identified as not an irregular object (e.g., a cheek, finger or palm).

Referring to FIG. 2, patch irregularity determination methodology 120 begins with the computation of a dispersion image (block 200). In general, the dispersion image (denoted [DISP] in FIG. 2) may be any high-pass filtered version of the initial proximity image [PROX]. In one embodiment, the [DISP] image is generated using a form of unsharp masking as follows:

$$[DISP] = [PROX] - [SMTH] \quad \text{EQ. 1}$$

Next, the total energy for each patch [P1, P2, . . . Pn] is computed (block 205). In one embodiment, for example, a patches’ total energy may be calculated by summing the square of each pixel value in the patch. This may be expressed mathematically as follows:

$$\text{Total Energy in Patch } p = E_p = \sum_{i,j \text{ in } p} [DISP_{[i][j]}^2] \quad \text{EQ. 2}$$

As noted in FIG. 2, total patch energy values resulting from operations in accordance with block 205 are denoted [E1, . . . En].

7

The total energy between adjacent pixels in a patch is then determined (block **210**). To reduce the effect of energy spikes for pixel patches straddling an edge, the summations below should neglect (i.e., assume a value of zero) contributions from pixels whose neighboring pixels are at the image's border, see EQ. 3. For the same reason, the summations below should ignore contributions from pixels whose neighboring pixels are from a different patch.

$$\begin{aligned} \text{Total Spatial Energy for Patch } p &= SE_p \\ &= \left(\begin{aligned} &\sum_{i,j \text{ in } p} \left(\frac{[DISP_{[i][j]}] - [DISP_{[i+1][j]}}{[DISP_{[i][j]}]} \right)^2 + \\ &\sum_{i,j \text{ in } p} \left(\frac{[DISP_{[i][j]}] - [DISP_{[i-1][j]}}{[DISP_{[i][j]}]} \right)^2 + \\ &\sum_{i,j \text{ in } p} \left(\frac{[DISP_{[i][j]}] - [DISP_{[i][j+1]}}{[DISP_{[i][j]}]} \right)^2 + \\ &\sum_{i,j \text{ in } p} \left(\frac{[DISP_{[i][j]}] - [DISP_{[i][j-1]}}{[DISP_{[i][j]}]} \right)^2 \end{aligned} \right) \div 4 \end{aligned} \quad \text{EQ. 3}$$

The sum is divided by 4 because each pixel gets counted once for each direction in the proximity image (left, right, up and down). As noted in FIG. 2, total patch spatial energy values resulting from operations in accordance with block **210** are denoted [SE1, . . . SEN]. Next, the energy associated with each patches' peak pixel is determined (block **215**) as follows:

$$\text{Peak Energy for Patch } p = PE_p = \max_{i,j \text{ in } p} ([DISP])^2 \quad \text{EQ. 4}$$

As noted in FIG. 2, peak patch energy values resulting from operations in accordance with block **215** are denoted [PE1, . . . PEN].

Finally, an irregularity measure for each patch is calculated (block **220**). In one embodiment, the irregularity measure is defined as the ratio of a patches' spatial energy minus its peak energy to the patches' total energy:

$$\text{Irregularity Measure for Patch } p = IM_p = \frac{SE_p - PE_p}{E_p} \quad \text{EQ. 5}$$

As noted in FIG. 2, patch irregularity measure values resulting from operations in accordance with block **220** are denoted [IM1, . . . IMn]. Alternative embodiments might discard any negative pixels values generated during computation of pixel energy values, or take absolute pixel values rather than squaring pixel values when calculating patch energies.

In another embodiment, the irregularity measure may be based on the proximity image as a whole. That is, the entirety of the dispersion image (i.e., all pixels) may be treated as a single "patch" for purposes of generating an irregularity measure value. One benefit to this approach is that abnormal touch-surface surface conditions may be detected, and responded to, prior to segmentation operations in accordance with block **125** (see FIG. 1). Illustrative abnormal touch-surface surface conditions include, but are not limited to,

8

liquid (e.g., water or sweat) on the touch-surface or multiple irregular objects in close proximity to or in contact with the touch-surface (e.g., coins and/or keys). When these conditions are detected, it may be beneficial to acquire new sensor element baseline values. In addition, if multiple touch-surface sensor sampling frequencies are employed an irregularity measure may be computed at each of the frequencies. If one or more of the computed irregularity measure values is greater than a specified threshold as discussed above, the sampling frequencies associated with the above-threshold values may be deemed to be affected by an excessive amount of noise and ignored (e.g., radio frequency noise). Periodic determination of frequency-dependent irregularity measures in this manner may be used to detect when such noise sources occur and when they disappear. For example, due to a touch-surface devices operating environment changes.

In general, an oddly shaped collection of pixels (i.e., a patch) can require a relatively large set of numbers to define its boundary and signal value at each pixel within the patch. To reduce the computational complexity of identifying, distinguishing and tracking touch events, however, it is advantageous to characterize patches identified in accordance with block **125** with as few numbers as practical. Because most patches from flesh contact tend to have an elliptical shape, one approach to patch parameterization is to fit an ellipse to each patch. One benefit of this approach is that an ellipse is completely described by a relatively small collection of numbers—its center coordinates, major and minor axis lengths, and major axis orientation.

Referring again to FIG. 1, using this approach known centroid or center-of-mass computations may be used to parameterize each patch (block **135**). In general, a patches' centroid may be determined using these techniques and the [CNST'] image (see block **130**). In addition, the [CNST'] image may be used to generate patch covariance matrices whose Eigenvalues identify a patches' major and minor radii and whose Eigenvectors identify the patches' orientation. For contact discrimination operations (see discussion below regarding block **140**), the following patch characteristics are also computed:

$$\text{Total Signal for Patch } p = \sum_{i,j \text{ in } p} [CNST'_{[i][j]}] \quad \text{EQ. 6}$$

$$\text{Signal Density for Patch } p = \frac{(\text{Total Signal for Patch } p)}{(\text{Geometric Mean Radius of Patch } p)} \quad \text{EQ. 7}$$

In another embodiment, patch signal density may be approximated by:

$$\text{Signal Density for Patch } p = \frac{(\text{Total Signal for Patch } p)}{(\text{Number of Pixels in Patch } p)} \quad \text{EQ. 8}$$

Prior art techniques to discriminate between objects that actually contact a touch-surface from those that are merely hovering above it have relied upon a patches' total signal parameter (see, for example, EQ. 6). This approach, however, is very dependent upon the size of the object being identified. That is, prior art techniques that threshold on a patches' total signal value generally only work well for objects of a single size. For example, a total patch signal threshold selected to identify a fingertip contact could trigger detection of a thumb or palm when those objects are far above the touch-surface.

Such a situation can lead to the mis-activation of keys, buttons or other control elements, the activation of control elements prior to surface contact and the mis-identification of patches (e.g., identifying a patch actually caused by a palm as a thumb).

In contrast, a discrimination technique in accordance with one embodiment of the invention uses a patches' signal density parameter (see, for example, EQs. 7 and 8). It has been found that this approach provides a robust means to distinguish objects that contact the touch-surface from those that are held or hovering above the surface—regardless of the object's size. For instance, the same density threshold can discriminate surface contact for fingers (adult and children), thumbs, palms and cheeks.

If the patch signal density parameter is normalized such that a firm fingertip contacting the touch-surface produces a peak value of 1, then a lightly brushing contact typically produces values slightly greater than 0.5 (e.g., half the normalized value) while a hovering object would produce a patch density value generally less than 0.5. It will be recognized that what constitutes "slightly greater" or "slightly less" is dependent upon factors such as the type of sensor elements used and their physical layout. Accordingly, while the precise determination of a threshold value based on patch signal density will require some experimentation, it would be within the purview of an artisan of ordinary skill with benefit of this disclosure.

It has also been determined that fingernail touches produce patch signal density values generally less than approximately 0.5. This is because the non-conductive fingernail holds the conductive finger flesh more than approximately 1 millimeter above the touch-surface. Accordingly, a threshold operation based on patch signal density is also a reliable means for discriminating between fleshy fingertip touches and back-of-fingernail touches.

With patch parameterization complete, the various types of touch-surface contacts may be discriminated (block 140). Using the parameters identified above, it is possible to robustly and reliably distinguish large objects (e.g., cheeks and palms) from other objects (e.g., fingers and thumbs), irregular objects (e.g., ears) from regular objects (e.g., fingers, thumbs, cheeks and palms) and finger-clasp actions (e.g., when a user claps a multi-touch touch-surface device to put it into or withdraw it from a pocket). Identification of and discrimination between these types of touch-surface inputs permits an associated device to be controlled in a more robust manner. For example, in one embodiment detection of a large object may be used to transition the device from one operational state (e.g., off) to another (e.g., on). In another embodiment, input identified as the result of a large or irregular object, which might normally cause a state transition, may be safely ignored if in one or more specified states. For example, if a touch-surface telephone is already in an "on" or "active" state, identification of a large or irregular object may be ignored.

As previously noted, it can be advantageous to distinguish large objects (e.g., cheeks and palms) from small objects (e.g., fingertips), regardless of whether the objects are hovering a few millimeters above the touch-surface or are pressed firmly against the surface. It has been found that a contact's minor radius measure provides a robust discriminative measure to accomplish this. If a patches' minor radius exceeds a specified threshold, the contact can reliably be classified as a cheek—as opposed to a finger or thumb, for example. This same measurement can also detect a nearby leg (e.g., thigh) through a few millimeters of fabric (e.g. when a device is inserted in the pocket with its touch-surface facing the body).

This measurement has been found to be so robust that if other patches appear on the surface with smaller minor radii (e.g. from an earlobe), they may be safely ignored. Referring to FIG. 3, illustrative empirical data is shown that illustrates the distinction between cheek contacts 300 and other contacts 305 (e.g., fingertips and thumbs) based on patch minor radii. While the exact values for patch contacts may vary from sensor to sensor and population to population, it is clear from FIG. 3 that threshold 310 may be made anywhere between approximately 11 millimeters and approximately 15 millimeters. (In this and the following data plots, patch signal density values are normalized to 1 for a fully contacting fingertip.) While threshold 310 is described by a constant value (i.e., dependent only upon patch minor radius), this is not necessary. For example, threshold 310 may be described by a linear or non-linear relationship between multiple parameters such patch minor-radius and patch signal density (see discussion below regarding FIG. 4).

A similar size testing may be performed using a patches' major or geometric mean radius (i.e.,

$$\sqrt{(\text{patch major axis radius})(\text{patch minor axis radius})},$$

the minor-radius discrimination described here has been found to be superior because it is better able to discriminate between thumbs or flattened fingers. (Flattened fingers may produce major radii as large as a cheek major radius, but their minor radii are typically no larger than a normal fingertip touch.)

It will be recognized that distinguishing a palm contact from fingertip or thumb contacts can be especially difficult because the patch radii resulting from a palm contact for people with small hands may approach the patch radii caused by thumb or fingertip contacts for people with large hands. These types of contacts may also be distinguished in accordance with the invention using the patch minor radius parameter. Referring to FIG. 4, illustrative empirical data is shown that illustrates the distinction between palm contacts 400 and other contacts 405 (e.g., fingertips and thumbs) based on patch minor radii. It has been found that patch signal density values tend to be low for hovering contacts of any size, and saturate at a level independent of object size as the object presses firmly onto the touch-surface. Thus, the palm versus other object decision threshold 410 may be reduced for contacts with lower signal density because hovering or lightly touching fingers produce lower minor radii than firmly touching fingers, whereas palms tend to produce large minor radii even when hovering. Accordingly, decision threshold 410 may be represented by a straight curve with a small positive slope. While the exact values for patch contacts will vary as noted above, it is clear from FIG. 4 that threshold 410 may be made to distinguish palm contacts from other contacts. Using this approach, there is virtually no risk that a hovering palm (a contact that typically produces a patch signal density value similar to that of a touching finger) will mistakenly be interpreted as a cursor move or button activation (e.g., a "click" event).

Ear and earlobe contacts can generate patches that are roughly the same size as those generated by fingers and thumbs. It has been found, however, that the creases, ridges, and generally rough topography of the ear do produce proximity images unique from fingers and thumbs, at least if the imaging sensor (i.e., touch-surface) covers a significant por-

11

tion of the ear (i.e. not just the fleshy lobule). The irregularity measure described above is one way to characterize contact roughness (see EQ. 5). This permits a robust means to discriminate between contacts due to ears and earlobes from contacts due to fingers, thumbs, cheeks, thighs and palms. It has been found that the defined irregularity measure tends to give values between 1.0 to 2.0 for ear and earlobe contacts while regular (e.g., smooth) contacts attributable to fingers, thumbs, palms and cheeks give values less than about 1.0. Referring to FIG. 5, illustrative empirical data is shown that illustrates the distinction between ear contacts **500** and other contacts **505** (e.g., fingertips, thumbs and cheeks) based on the above defined irregularity measure. In one embodiment, threshold **510** comprises a linear step-like or spline structure with a first level at an irregularity measure of between approximately 1.0 to 1.2 and a second level at approximately between 1.1 and 1.2. In another embodiment, a single linear function having a positive slope may be used. In yet another embodiment, higher level functions may be used to segregate the various contact types. As noted above, while the exact values for patch contacts may vary from those shown in FIG. 5, it is clear that most rough object contacts may be distinguished from most smooth or regular object contacts using the defined irregularity measure—where the exact nature or form of a decision threshold (e.g., threshold **510**) is dependent upon the precise implementation, operational goals and capabilities of the target multi-touch device.

In one embodiment, successive proximity images (aka “frames”) are used to track objects as they move across a touch-surface. For example, as an object is moved across a touch-surface, its associated patch(es) may be correlated through overlap calculations. That is, patches identified in successive images that overlap in a specified number of pixels (or fraction of patch pixels) may be interpreted to be caused by the same object. In such an embodiment, the maximum patch minor radius over the life of the tracked contact may be compared to the thresholds discussed above (e.g., thresholds **310** in FIG. 3, **410** in FIG. 4 and **510** in FIG. 5). This approach ensures that a, for example, palm contact does not lose its palm identity should its minor radius temporarily fall below the decision threshold (e.g., **410**). It is further noted that if a decision threshold is not a constant value (e.g., **310**) but rather some curve (e.g., **410** and **510**), it may be advantageous to apply a density-correction to the instantaneous minor radius prior to the maximum minor radius accumulation operation described here.

When taking a multi-touch device in and out of a pocket, or otherwise generally handling it, users should have the freedom to clasp their hand around it without producing spurious input. Such finger-clasps can be detected via any one of the following criteria:

Identification (via block **125** in FIG. 1) of five, six or more distinct surface contacts. (For a touch-surface the size of a deck of cards, this many fingertips won’t normally fit on the surface, but since the phalange joints of each flattened finger may get segmented into more than one contact patch, two or three flattened fingers may generate five or more contact patches.)

Two, three or more contact patches are identified and the major radius of at least two exceed approximately 15 millimeters to 18 millimeters. Since cheeks and other large body parts normally produce just one patch with large major radius, the requirement for two or three large patches prevents this test from triggering on a cheek, leg or chest. Also, the requirement for multiple large major

12

radii prevents this test from triggering on a couple fingertips accompanied by a long thumb laid flat against the surface.

In another embodiment of the invention, multi-touch processing methodology may include far-field processing. As used herein, far-field processing refers to the detection and processing associated with bodies (e.g., fingers, palms, cheeks, ears, thighs, . . .) that are close to (e.g., less than one millimeter to more than a centimeter) but not in contact with the touch-surface. The ability to detect far-field objects may be beneficial in touch-surface devices that, during normal use, are brought into close proximity to a user. One example of such a device is a telephone that includes touch-surface for user input (e.g., dialing).

Referring to FIG. 6, in one embodiment initial far-field processing may be performed after proximity image data is acquired. That is, after operations in accordance with block **105** in FIG. 1. If the far-field measurement is designed to remain negative in the absence of any object near the touch-surface, and only become positive in the presence of a large object, a first step subtracts a small noise factor from the initially acquired proximity image to create a negative-background far-field image (block **600**):

$$\text{Negative Far-Field Image} = [\text{PROX}] - (\text{Noise Factor}) \quad \text{EQ. 9}$$

In one embodiment, the noise factor may be set to between approximately 1 and 2 standard deviations of the average noise measured or expected over the entire image. This will cause most pixels in the resulting negative far-field image to be slightly negative rather than neutral in the absence of any touch-surface contact. As noted in FIG. 6, the negative far-field image resulting from operations in accordance with block **600** is denoted [NFAR].

Next, each pixel in the [NFAR] image is saturated to the highest level expected from an object hovering a few millimeters from the touch-surface (block **605**). In one embodiment, the resulting far-field saturation image (denoted [SFAR] in FIG. 6) is generated as shown in Table 3.

TABLE 3

| Illustrative Far-Field Saturation Operations | |
|--|---------------------------------------|
| For each pixel in the initial far-field image: | |
| If [NFAR] > (Far-Field Saturation Limit) | [SFAR] = (Far-Field Saturation Limit) |
| Else | [SFAR] = [NFAR] |

Since a goal of far-field operations is to be sensitive to large numbers of pixels only slightly activated (e.g., having small positive values), without being overwhelmed by a few strongly active pixels (e.g., having large positive values), the saturation limit value should be less than the peak pixel value from fingers or thumbs hovering within approximately 1 to 2 millimeters of the touch-surface, but not so low as to cause the resulting [SFAR] image to lose too much information content. While the precise far-field saturation limit value will vary from implementation to implementation (due to differences in sensor element technology and associated circuitry), it has been determined empirically that a suitable value will generally lie between +3 standard deviations and +6 standard deviations of noise associated with the initial far-field image. (Again, this noise may be on a per-pixel, or whole image basis.)

If the initial proximity image [PROX] contains a significant amount of noise, it may be beneficial to filter the [SFAR]

image (block 610). In one embodiment, a finite impulse response filter technique may be used wherein two or more consecutive [SFAR] images are averaged together. In another embodiment, an infinite impulse response filter technique may be used to generate a smoothed image. It will be recognized that an infinite impulse response filter generates a weighted running average (or auto-regressive) image. In one embodiment, for example, an infinite impulse response filter combines the current far-field saturated image (e.g., [SFAR]_{new}) with the immediately prior far-field saturated image (e.g., [SFAR]_{prior}) in a one-third to two-thirds ratio. As noted in FIG. 6, a filtered far-field saturated image generated in accordance with block 610 is denoted [FARF].

Following image segmentation operations in accordance with block 125 (see FIG. 1), a weighted average of non-linearly scaled background pixel values may be used to generate a scalar far-field indicator value (FAR-FIELD) in accordance with the invention as follows:

$$\text{FAR-FIELD} = \frac{\sum_{\text{background } i,j} \text{ENeg}([FARF]_{[i][j]}) \times [LOC]_{[i][j]}}{\sum_{\text{background } i,j} [LOC]_{[i][j]}} \quad \text{EQ. 10}$$

where the ENeg() function non-linearly amplifies pixel values below a threshold (e.g., zero) and [LOC] represents a pixel weighting mechanism. As indicated in EQ. 10, only proximity image background pixels contribute to the computed FAR-FIELD value. That is, pixels identified as belonging to a patch during image segmentation operations are excluded during far-field measurement operations.

In one embodiment, the ENeg() function disproportionately emphasizes the contributions from background pixels as follows:

$$\text{ENeg}(\text{pixel value}) = \begin{cases} \text{pixel value} & \text{for } 0 \leq \text{pixel value} \leq B \\ 2 \times \text{pixel value} & \text{for } (-B \div 2) \leq \text{pixel value} < 0 \\ B + (3 \times \text{pixel value}) & \text{for } \text{pixel value} < (-B \div 2) \end{cases} \quad \text{EQ. 11}$$

where B represents a far-field saturation limit value. Empirically determined, B is chosen to permit a small number of negative pixels to cancel out a finger or thumb-sized patch of positive pixels. In this way, only a nearly full coverage cheek-sized patch of positive pixels, plus a small remainder of neutral/background pixels, can produce a strongly positive far-field measurement.

While not necessary, disproportionately emphasizing the contributions from background pixels in accordance with EQs. 10 and 11 permits the FAR-FIELD measurement to be more selective for bodies large enough to positively affect most of a touch-surface's pixel (e.g., cheeks and legs), while not being overly influenced by medium-sized objects (e.g., hovering thumbs). For example, if a hovering thumb causes half of a touch-surface's sensor elements to have a slightly above-background pixel value, disproportionately emphasizing the half that remain below background will keep the measured FAR-FIELD value below zero—indicating no large object is “near” the touch-surface (e.g., within 1 to 3 centimeters). In another embodiment, background pixels may be linearly combined (e.g., summed).

As noted above, [LOC] represents a pixel weighting mechanism. In general, there is one value in [LOC] for each pixel present in the touch-surface. If it is desired to consider all touch-surface pixels equally, each value in the [LOC] image may be set to 1.0 (or some similar constant value). For hand-held form-factors selectivity for large bodies may be improved, however, by lowering the weights near the bottom and side edges (for example, to values between 0.1 and 0.9). Doing this can lessen false-positive contributions from a hand whose fingers wrap around the device during (clasp) operations. In mobile phone form-factors, to retain sensitivity to ear and cheek far-fields, the weights along the top edge (where thumbs and fingers are less likely to hover or wrap) may be kept at full strength.

Returning now to FIG. 1 at block 140, when far-field measurements are taken into account during contact discrimination operations, a FAR-FIELD value greater than a specified threshold (e.g., zero) indicates a large “near by” object has been detected. As previously noted, this information may be used to transition the touch-surface device into a specified mode (e.g., on, off or low power). In addition, far-field measurements may be combined with other measurements (e.g., the irregularity measure) to provide improved ear detection. For example, when a touch-surface is partly against an ear and also hovering a centimeter or two from a cheek, a weak ear pixel patch may be segmented in accordance with block 125 at the top of the screen. Meanwhile, the middle and bottom of the touch-surface would only be affected by the cheek's far-field. Even if the FAR-FIELD measurement as taken outside the ear patch is not strong enough to exceed the specified far-field threshold on its own, the FAR-FIELD value can be added or otherwise combined with (weak) patch density and irregularity measure indicators such that the sum or combination surpasses an ear detection threshold.

In addition, one or more proximity sensors may be positioned above the touch-surface's top edge or around, for example, a telephone's receiver opening. Illustrative proximity sensors of this type include, but are not limited to, active infrared-reflectance sensors and capacitance-sensitive electrode strips. In a mobile telephone form-factor, when the device is held such that the receiver is centered on the ear canal, ear ridges may trigger the proximity sensor. Meanwhile the earlobe may cause a small pixel patch in the top portion of the touch-surface. Discrimination operations in accordance with block 140 could decide that when a pixel patch at the top of the touch-surface is accompanied by any significant receiver proximity trigger, the pixel patch must be an ear, not a finger. In another embodiment, the same conditions but with a significant FAR-FIELD value for the lower portion of the touch-surface (indicating a hovering cheek) may be used to trigger detection of an ear at the top of the touch-surface. Generally speaking, one or more of signal density (see EQs. 7 and 8), patch irregularity (see EQ. 5), FAR-FIELD measurement (see EQ. 10) and proximity sensor input may be combined (e.g., a weighted average) so that ear detection can trigger when multiple indicators are weakly active, or just one indicator is strongly active. Finally, it is noted that contact discrimination parameters such as a patches' centroid, minor axis radius, patch irregularity (EQ. 5), patch signal density (EQs. 7 and 8), far-field (EQ. 10) and proximity sensor input (if available) may be (low-pass) filtered to help counteract their often sporadic nature. This may be particularly beneficial if the filters employ adaptive time constants that rise quickly in response to rising input values, but decay more slowly when input values drop and/or are missing.

Referring to FIG. 7, a touch-surface device 700 of the type described herein is shown in block diagram form. As used herein, a touch-surface device is any device that receives user input from a multi-touch capable touch-surface component (i.e., an input unit that provides user input in the form of a proximity image). Illustrative touch-surface devices include, but are not limited, to tablet computer system, notebook computer systems, portable music and video display devices, personal digital assistants and mobile telephones.

As illustrated, touch-surface element 705 includes sensor elements and necessary drive and signal acquisition and detection circuitry. Memory 710 may be used to retain acquired proximity image information (e.g., [PROX] image data) and by processor 715 for computed image information (e.g., patch characterization parameters). Processor 715 represents a computational unit or programmable control device that is capable of using the information generated by touch-surface element 705 to determine various metrics in accordance with FIG. 1. In addition, external component 720 represents an entity that uses the generated information. In the illustrative embodiment, external component 720 may obtain information from processor 715 or directly from memory 710. For example, processor 715 could maintain a data structure in memory 710 to retain indication of, for example, large body contact status, large body far-field status, irregular object indication status, proximity sensor status (if utilized), flat finger clasp status and normal finger touch status. In one embodiment, each status may be indicated by a single Boolean value (i.e., a flag).

Various changes in the materials, components, circuit elements, as well as in the details of the illustrated operational methods are possible without departing from the scope of the following claims. It will be recognized, for example, that not all steps identified in FIG. 1 need be performed while others may be combined and still others divided into more refined steps. By way of example, in one embodiment patch peripheral pixel noise is not suppressed (see block 130). In another embodiment, patch peripheral pixel noise suppression is employed but no patch irregularity measure is made (see block 120). In still another embodiment, both patch peripheral pixel noise suppression and patch irregularity measures are determined and used. For embodiments that do not employ peripheral patch pixel noise reduction techniques, patch parameterization operations in accordance with block 135 use the [CNST] image and not the [CNST'] image as discussed above (see Table 2). In addition, patch parameterization operations in accordance with block 135 do not need to rely on statistical ellipse fitting. They could instead sum patch perimeter pixels and compare the obtained value to all patch pixels or attempt polygonal fits. Further, calibration operations (see Tables 1 and 2) may be delayed until, or made part of, image segmentation operations (block 125). In addition, it may be beneficial for purposes of image segmentation to mark pixels that are at, or have been set to, the background level (e.g., during operations in accordance with block 110). It is also noted that because the criteria for identifying a finger clasp are orthogonal to large body contact detection (see discussion above in [044]), flat finger clasps may be used as a distinct gesture commanding a particular operation like locking the screen, going to sleep, or terminating a telephone call.

With respect to illustrative touch-surface device 700, touch-surface element 705 may incorporate memory (e.g., 710) and/or processor (e.g., 715) functions. In addition, external component 720 may represent a hardware element (e.g., a host processor) or a software element (e.g., a driver utility).

Finally, acts in accordance with FIGS. 1, 2 and 6 may be performed by a programmable control device executing

instructions organized into one or more program modules. A programmable control device may be a single computer processor, a special purpose processor (e.g., a digital signal processor, "DSP"), a plurality of processors coupled by a communications link or a custom designed state machine. Custom designed state machines may be embodied in a hardware device such as an integrated circuit including, but not limited to, application specific integrated circuits ("ASICs") or field programmable gate array ("FPGAs"). Storage devices suitable for tangibly embodying program instructions include, but are not limited to: magnetic disks (fixed, floppy, and removable) and tape; optical media such as CD-ROMs and digital video disks ("DVDs"); and semiconductor memory devices such as Electrically Programmable Read-Only Memory ("EPROM"), Electrically Erasable Programmable Read-Only Memory ("EEPROM"), Programmable Gate Arrays and flash devices.

The invention claimed is:

1. A method to discriminate input sources to a touch-surface device, comprising:
 - obtaining a proximity image;
 - segmenting the proximity image to identify a plurality of patches;
 - determining a minor axis radius value for each of the plurality of patches;
 - identifying one of the plurality of patches as being associated with a large object if the minor axis radius value of the patch is above a first specified threshold; and
 - using the identified patch to control an operation of a touch-surface device.
2. The method of claim 1, wherein the large object comprises a cheek.
3. The method of claim 1, wherein the large object comprises a leg.
4. The method of claim 1, further comprising:
 - identifying a second of the plurality of patches as being associated with a palm if the minor axis value of the second patch is less than the first specified threshold and greater than a second specified threshold; and
 - using the identified second patch to control an operation of a touch-surface device.
5. The method of claim 4, further comprising:
 - identifying a third of the plurality of patches as being associated with a finger if the minor axis value of the third patch is less than the second specified threshold; and
 - using the identified third patch to control an operation of a touch-surface device.
6. The method of claim 5, wherein the patch associated with the finger contact comprises a patch associated with a thumb.
7. The method of claim 1, wherein the first specified threshold is represented by a constant function.
8. The method of claim 4, wherein the second specified threshold is represented by a constant function.
9. The method of claim 1, wherein the first specified threshold is represented by a linear function.
10. The method of claim 4, wherein the second specified threshold is represented by a linear function.
11. The method of claim 1, wherein the first specified threshold is represented by a non-linear function.
12. The method of claim 4, wherein the second specified threshold is represented by a non-linear function.
13. The method of claim 1, wherein one or more of the plurality of patches are associated with objects that are in physical contact with a surface of the touch-surface device.

17

14. The method of claim 1, wherein one or more of the plurality of patches are associated with objects that are not in physical contact with a surface of the touch-surface device.

15. The method of claim 4, wherein the second specified threshold is represented by a linear function.

16. The method of claim 1, wherein the act of obtaining comprises obtaining a proximity image from a capacitive touch-surface device.

17. The method of claim 1, wherein the act of obtaining comprises obtaining a proximity image from a pressure-sensitive touch-surface device.

18. The method of claim 1, wherein the act of obtaining comprises:

obtaining a first proximity image, the first proximity image comprising a plurality of pixels, each pixel having a value; and

subtracting sensor element baseline values from the plurality of pixels values in the first proximity image.

19. The method of claim 1, wherein the act of obtaining comprises:

obtaining a first proximity image; and

filtering the first proximity image to generate a filtered proximity image.

20. The method of claim 19, wherein the act of filtering comprises spatially filtering the first proximity image.

21. The method of claim 20, wherein the act of spatially filtering comprises inserting a border around the first proximity image prior to spatially filtering the first proximity image.

22. The method of claim 19, wherein the act of filtering comprises temporally filtering the first proximity image with a second proximity image.

23. The method of claim 19, further comprising constraining pixel values associated with the filtered proximity image to be less than a specified value.

24. The method of claim 1, wherein the touch-surface device comprises one of the following devices: tablet computer system, notebook computer system, portable music player, portable video player, personal digital assistant and mobile telephone.

25. A program storage device, readable by a programmable control device, comprising instructions stored thereon for causing the programmable control device to perform the method of claim 1.

26. A portable electronic device, comprising:

a multi-touch input touch-surface component;

means for receiving a proximity image from the multi-touch input touch-surface; and

processing means for performing acts in accordance with claim 1.

27. The device in accordance with claim 26, wherein the portable electronic device comprises a tablet computer system.

28. The device in accordance with claim 26, wherein the portable electronic device comprises a hand-held computer system.

29. The device in accordance with claim 26, wherein the portable electronic device comprises a mobile telephone.

30. The device in accordance with claim 26, wherein the portable electronic device comprises a portable music player system.

31. The device in accordance with claim 26, wherein the portable electronic device comprises a portable video player system.

18

32. A method to identify an input source to a multi-touch touch-surface device, comprising:

obtaining a proximity image;

segmenting the proximity image to identify a patch;

determining a minor axis radius value for the patch;

identifying the patch as being associated with a large object if the minor axis radius value of the patch is above a first specified threshold; and

using the identified patch to control an operation of a multi-touch touch-surface device.

33. The method of claim 32, wherein the first specified threshold is represented by a constant function.

34. The method of claim 32, wherein the first specified threshold is represented by a linear function.

35. The method of claim 32, wherein the first specified threshold is represented by a non-linear function.

36. The method of claim 32, wherein the identified patch is associated with an object that is in physical contact with a surface of the touch-surface device.

37. The method of claim 32, wherein the identified patch is associated with an object that is not in physical contact with a surface of the touch-surface device.

38. A method to identify an input source to a multi-touch touch-surface device, comprising:

obtaining a proximity image;

segmenting the proximity image to identify a patch;

determining a minor axis radius value for the patch;

identifying the patch as being associated with a palm if the minor axis value of the patch is less than a first specified threshold and greater than a second specified threshold; and

using the identified patch to control an operation of a multi-touch touch-surface device.

39. The method of claim 38, wherein the first specified threshold is represented by a constant function.

40. The method of claim 38, wherein the first specified threshold is represented by a linear function.

41. The method of claim 38, wherein the first specified threshold is represented by a non-linear function.

42. The method of claim 38, wherein the identified patch is associated with an object that is in physical contact with a surface of the multi-touch touch-surface device.

43. The method of claim 38, wherein the identified patch is associated with an object that is not in physical contact with a surface of the multi-touch touch-surface device.

44. A method to identify an input source to a multi-touch touch-surface device, comprising:

obtaining a proximity image;

segmenting the proximity image to identify a patch;

determining a minor axis radius value for the patch;

identifying a patch as being associated with a finger if the minor axis value of the patch is less than a first specified threshold; and

using the identified patch to control an operation of a multi-touch touch-surface device.

45. The method of claim 44, wherein the first specified threshold is represented by a constant function.

46. The method of claim 44, wherein the first specified threshold is represented by a linear function.

47. The method of claim 44, wherein the first specified threshold is represented by a non-linear function.

48. The method of claim 44, wherein the identified patch is associated with an object that is in physical contact with a surface of the multi-touch touch-surface device.

49. The method of claim 44, wherein the identified patch is associated with an object that is not in physical contact with a surface of the multi-touch touch-surface device.

50. A program storage device, readable by a programmable control device, comprising instructions stored thereon for causing the programmable control device to perform the method of claim **32**.

51. The method of claim **32**, wherein the multi-touch touch-surface device comprises one of the following devices: tablet computer system, notebook computer system, portable music player, portable video player, personal digital assistant and mobile telephone.

52. A program storage device, readable by a programmable control device, comprising instructions stored thereon for causing the programmable control device to perform the method of claim **38**.

53. The method of claim **38**, wherein the multi-touch touch-surface device comprises one of the following devices: tablet computer system, notebook computer system, portable music player, portable video player, personal digital assistant and mobile telephone.

54. A program storage device, readable by a programmable control device, comprising instructions stored thereon for causing the programmable control device to perform the method of claim **44**.

55. The method of claim **44**, wherein the multi-touch touch-surface device comprises one of the following devices: tablet computer system, notebook computer system, portable music player, portable video player, personal digital assistant and mobile telephone.

56. A method to identify an input source to a multi-touch touch-surface device, comprising:

- obtaining a proximity image;
- segmenting the proximity image to identify a plurality of patches;
- determining that at least five of the identified patches are associated with finger contacts to a touch-surface;
- identifying the at least five identified patches as being associated with a finger-clasp operation;
- and using the identified finger-clasp operation to control an operation of a multi-touch touch-surface device.

57. The method of claim **56**, wherein the multi-touch touch-surface device comprises one of the devices selected from the group consisting of: a tablet computer system, a hand-held computer system, a portable music player system, a portable video player system.

58. The method of claim **56**, wherein the multi-touch touch-surface device comprises a mobile telephone.

59. A method to identify an input source to a multi-touch touch-surface device, comprising:

- obtaining a proximity image;
- segmenting the proximity image to identify a plurality of patches;
- determining that at least two of the identified patches have major axis radius values larger than approximately 15 millimeters;
- identifying the at least two identified patches as being associated with a fingerclasp operation; and
- using the identified finger-clasp operation to control an operation of a multitouch touch-surface device.

60. The method of claim **59**, wherein the multi-touch touch-surface device comprises one of the devices selected from the group consisting of: a tablet computer system, a hand-held computer system, a portable music player system, a portable video player system.

61. The method of claim **59**, wherein the multi-touch touch-surface device comprises a mobile telephone.

62. A method to identify an input source to a touch-surface device, comprising:

- obtaining a proximity image;
- segmenting the proximity image to identify one or more patches, each patch having a plurality of pixels, each pixel having a value;
- determining a signal density value for at least one of the one or more patches;
- identifying the at least one patch as being associated with an object contacting a touch-surface of a touch-surface device if the at least one patch has a signal density value greater than a specified value;
- identifying the at least one patch as being associated with an object hovering above the touch-surface if the at least one patch has a signal density value less than the specified value; and
- performing a control operation on the touch-surface device in response to the acts of identifying.

63. The method of claim **62**, wherein the signal density value is determined by dividing the sum of all pixel values in a patch by the number of pixels in the patch.

64. The method of claim **62**, wherein the signal density value is determined by dividing the sum of all pixel values in a patch by a radius of the patch.

65. The method of claim **64**, wherein the radius of the patch comprises a geometric mean radius of the patch.

66. The method of claim **62**, wherein the signal density value is determined by dividing the sum of all pixel values in a patch by the patches' area.

67. The method of claim **62**, wherein the control operation comprises causing the touch-surface device to change an operational state.

68. The method of claim **62**, wherein the control operation comprises performing a specified function.

69. The method of claim **62**, wherein the control operation comprises ignoring the object contacting the touch-surface.

70. The method of claim **62**, wherein the touch-surface device comprises one of the devices selected from the group consisting of: a tablet computer system, a hand-held computer system, a portable music player system, a portable video player system.

71. The method of claim **62**, wherein the touch-surface device comprises a mobile telephone.

72. A program storage device, readable by a programmable control device, comprising instructions stored thereon for causing the programmable control device to perform the method of claim **62**.

73. A method to identify an input source to a multi-touch touch-surface device, comprising:

- obtaining a proximity image;
- segmenting the proximity image to identify a plurality of patches;
- determining that at least two of the identified patches have major axis radius values larger than threshold;
- identifying the at least two identified patches as being associated with a finger-clasp operation; and
- using the identified finger-clasp operation to control an operation of a multi-touch touch-surface device.

74. The method of claim **73**, wherein the multi-touch touch-surface device comprises one of the devices selected from the group consisting of: a tablet computer system, a hand-held computer system, a portable music player system, a portable video player system.

75. The method of claim **73**, wherein the multi-touch touch-surface device comprises a mobile telephone.

UNITED STATES PATENT AND TRADEMARK OFFICE
CERTIFICATE OF CORRECTION

PATENT NO. : 7,855,718 B2
APPLICATION NO. : 11/619464
DATED : December 21, 2010
INVENTOR(S) : Wayne C. Westerman

Page 1 of 1

It is certified that error appears in the above-identified patent and that said Letters Patent is hereby corrected as shown below:

On page 3, in column 1, under "Other Publications", line 1, delete "GlivePoint®" and insert -- GlidePoint® --, therefor.

On page 3, in column 2, under "Other Publications", line 1, delete "Macine" and insert -- Machine --, therefor.

On page 3, in column 2, under "Other Publications", line 5, delete "Sysyems," and insert -- Systems, --, therefor.

On page 3, in column 2, under "Other Publications", line 7, delete "Sysyems," and insert -- Systems, --, therefor.

In column 15, line 58, delete "[044])," and insert -- [0044]), --, therefor.

In column 19, line 57, in claim 59, delete "fingerclasp" and insert -- finger-clasp --, therefor.

In column 19, line 59, in claim 59, delete "multitouch" and insert -- multi-touch --, therefor.

Signed and Sealed this
First Day of November, 2011



David J. Kappos
Director of the United States Patent and Trademark Office