



US007844142B2

(12) **United States Patent**  
**Mouli**

(10) **Patent No.:** **US 7,844,142 B2**  
(45) **Date of Patent:** **Nov. 30, 2010**

(54) **COMMUNICATION METHODS, METHODS OF FORMING AN INTERCONNECT, SIGNAL INTERCONNECTS, INTEGRATED CIRCUIT STRUCTURES, CIRCUITS, AND DATA APPARATUSES**

(75) Inventor: **Chandra Mouli**, Boise, ID (US)

(73) Assignee: **Micron Technology, Inc.**, Boise, ID (US)

(\*) Notice: Subject to any disclaimer, the term of this patent is extended or adjusted under 35 U.S.C. 154(b) by 1124 days.

(21) Appl. No.: **11/515,296**

(22) Filed: **Aug. 31, 2006**

(65) **Prior Publication Data**

US 2008/0069359 A1 Mar. 20, 2008

(51) **Int. Cl.**  
**G02B 6/12** (2006.01)  
**H04J 14/00** (2006.01)  
**H01L 21/00** (2006.01)  
**H01R 33/945** (2006.01)

(52) **U.S. Cl.** ..... **385/14; 385/53; 385/88; 385/89; 385/129; 385/130; 398/79; 438/29; 438/31; 439/577**

(58) **Field of Classification Search** ..... 385/14, 385/53, 88, 89, 92, 101, 129-132, 122; 439/577; 250/208.1; 398/79; 438/29, 31  
See application file for complete search history.

(56) **References Cited**

U.S. PATENT DOCUMENTS

5,562,838 A \* 10/1996 Wojnarowski et al. .... 216/24  
5,659,648 A \* 8/1997 Knapp et al. .... 385/129  
5,793,909 A \* 8/1998 Leone et al. .... 385/24  
6,539,156 B1 \* 3/2003 Dickson et al. .... 385/129  
6,821,146 B2 \* 11/2004 Tolmie ..... 439/577  
6,843,606 B2 \* 1/2005 Deane et al. .... 385/92  
6,862,396 B2 \* 3/2005 Dickson et al. .... 385/141

6,947,634 B2 \* 9/2005 Tanaka et al. .... 385/31  
7,170,142 B2 \* 1/2007 Wojcik et al. .... 257/449  
7,215,845 B1 \* 5/2007 Chan et al. .... 385/24  
7,366,373 B2 \* 4/2008 Hyde et al. .... 385/30  
7,427,165 B2 \* 9/2008 Benaron et al. .... 385/75  
7,447,396 B2 \* 11/2008 Hyde et al. .... 385/16  
7,454,095 B2 \* 11/2008 Baehr-Jones et al. .... 385/14  
7,583,882 B2 \* 9/2009 Guo ..... 385/131  
2002/0025101 A1 \* 2/2002 Kaatz ..... 385/14  
2003/0147616 A1 \* 8/2003 Dickson et al. .... 385/129  
2005/0104684 A1 \* 5/2005 Wojcik et al. .... 333/108  
2005/0111777 A1 \* 5/2005 Stenger et al. .... 385/14  
2005/0263675 A1 12/2005 Mouli ..... 250/208.1  
2005/0281524 A1 12/2005 Mouli ..... 385/129

(Continued)

**OTHER PUBLICATIONS**

“Fine tuning work function of indium tin oxide by surface molecular desing: Enhanced hole injection in organic electroluminescent devices”; Ganzorig et al.; Applied Physics Letters, vol. 79, No. 2; Jul. 9, 2001; pp. 272-274.

(Continued)

*Primary Examiner*—Brian M Healy  
(74) *Attorney, Agent, or Firm*—Wells St. John, P.S.

(57) **ABSTRACT**

Some embodiments include communication methods, methods of forming an interconnect, signal interconnects, integrated circuit structures, circuits, and data apparatuses. In one embodiment, a communication method includes accessing an optical signal comprising photons to communicate information, accessing an electrical signal comprising electrical data carriers to communicate information, and using a single interconnect, communicating the optical and electrical signals between a first spatial location and a second spatial location spaced from the first spatial location.

**50 Claims, 3 Drawing Sheets**

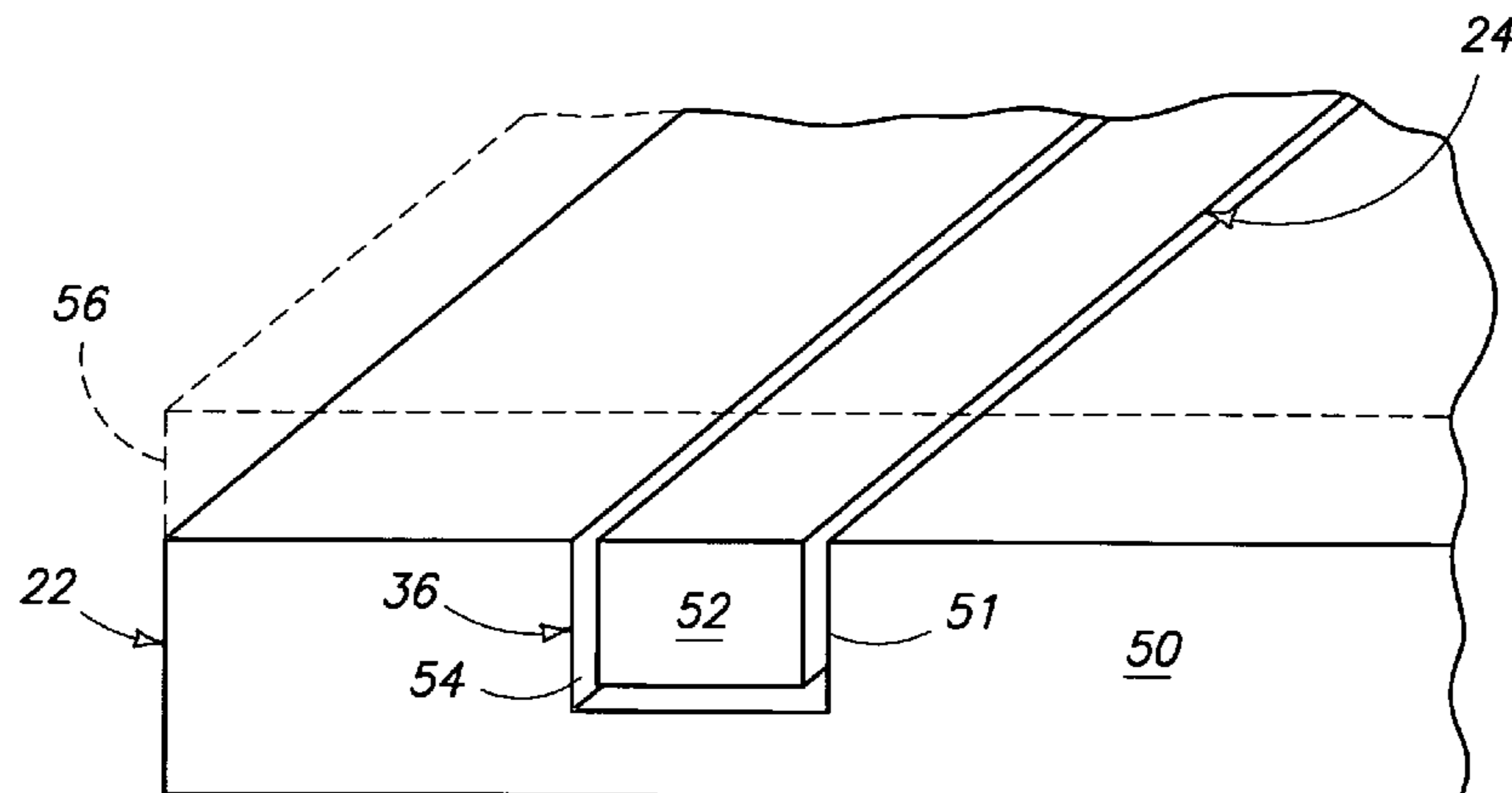

# US 7,844,142 B2

Page 2

---

## U.S. PATENT DOCUMENTS

2006/0006485 A1 1/2006 Mouli ..... 257/432  
2006/0186318 A1 8/2006 Mouli ..... 250/208.1  
2006/0186319 A1 8/2006 Mouli ..... 250/208.1  
2008/0069359 A1\* 3/2008 Mouli ..... 380/259  
2008/0080807 A1\* 4/2008 Kim et al. .... 385/14

## OTHER PUBLICATIONS

“Work function of indium tin oxide transparent conductor measured by photoelectron spectroscopy”; Park et al.; Applied Physics Letter 68 (19) May 6, 1996; pp. 2699-2701.

\* cited by examiner

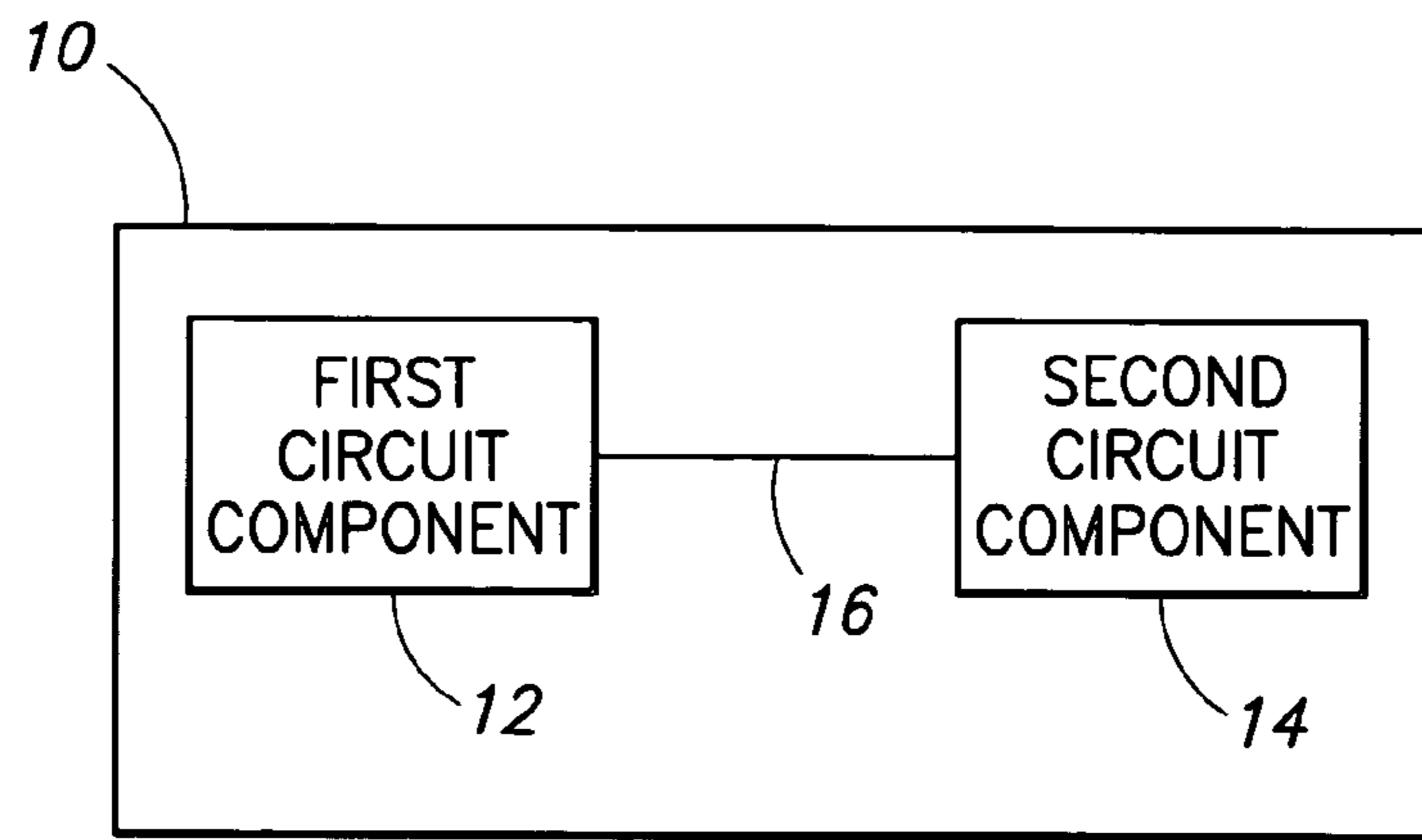

FIG. 1

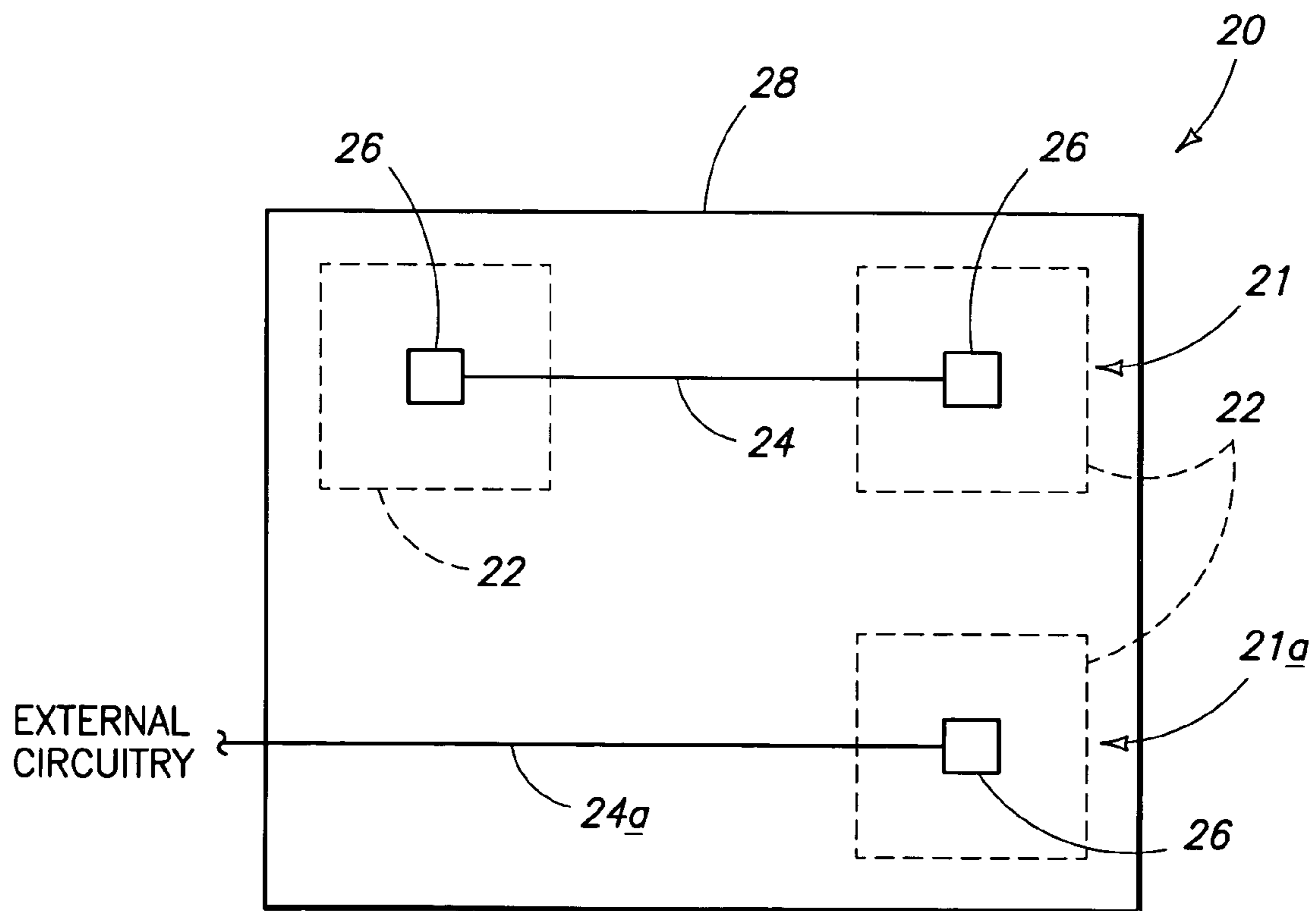
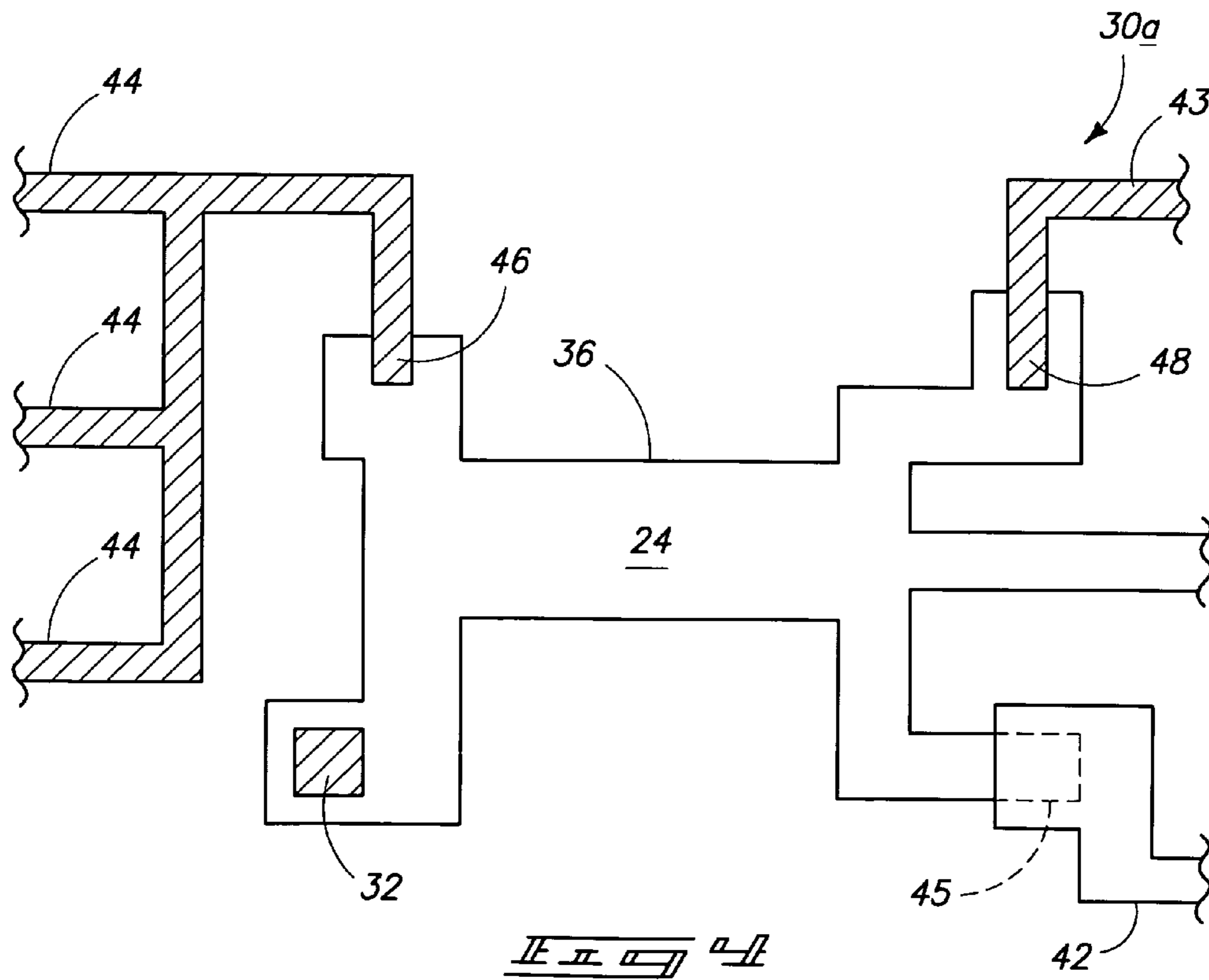
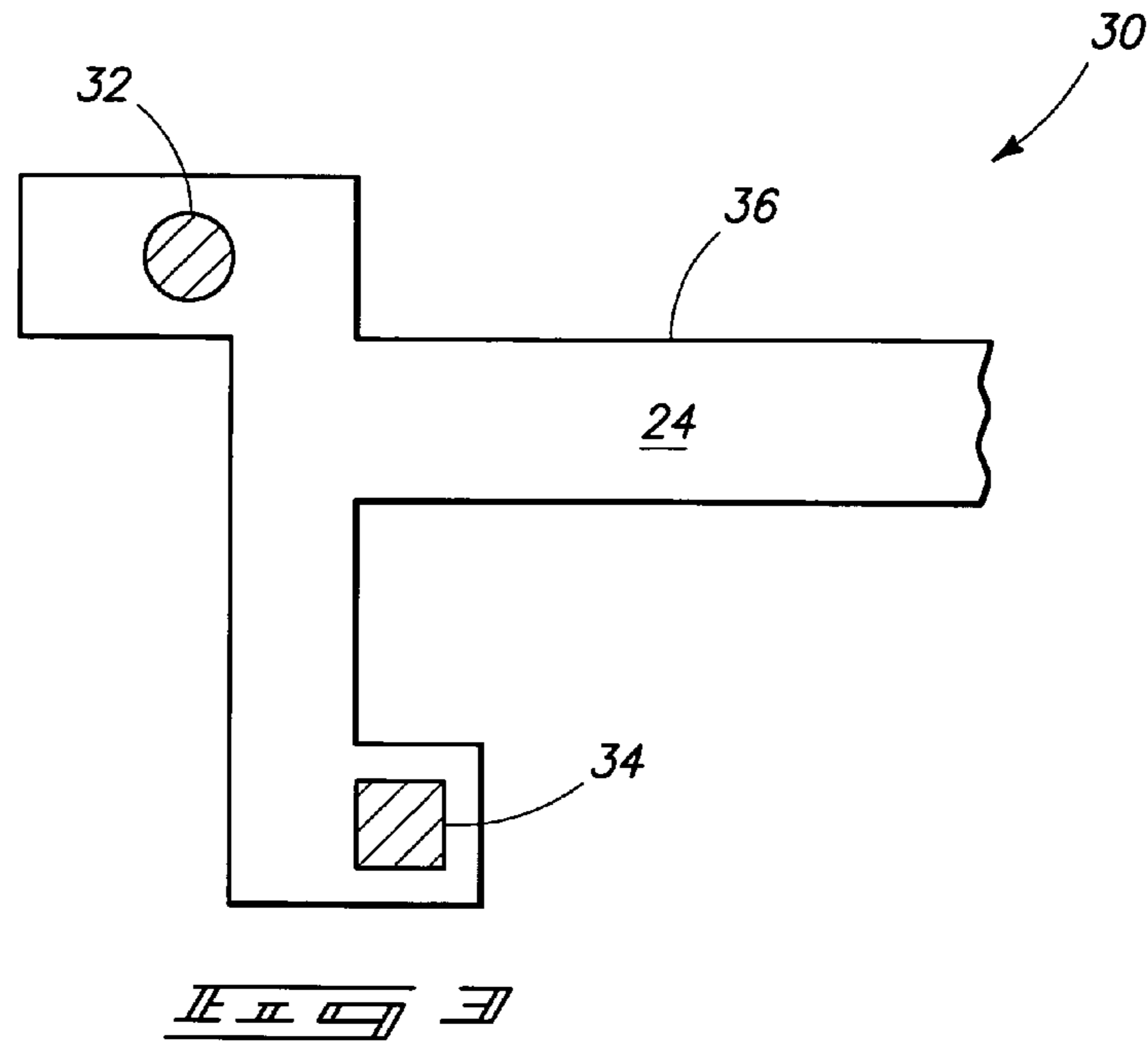
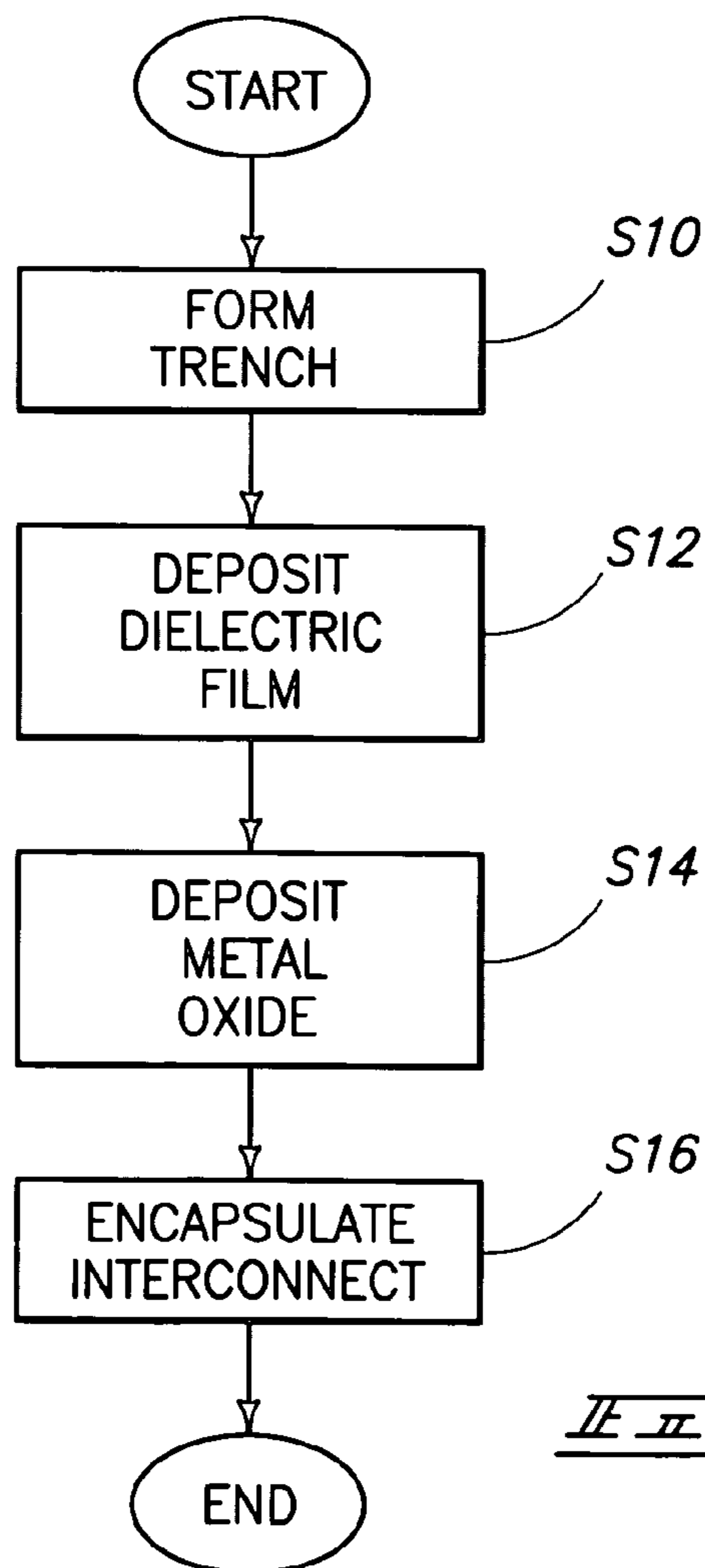
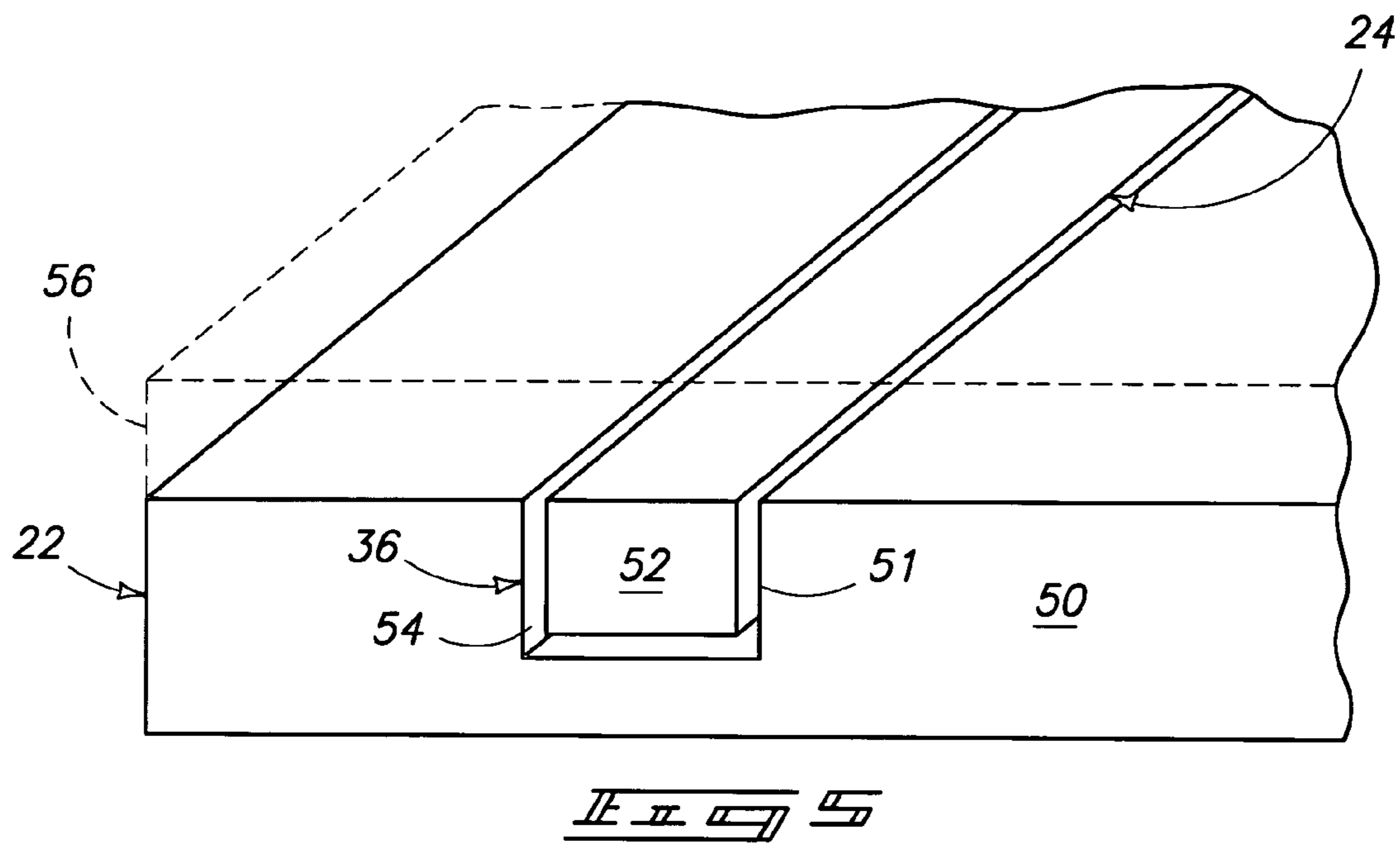

FIG. 2





1

**COMMUNICATION METHODS, METHODS  
OF FORMING AN INTERCONNECT, SIGNAL  
INTERCONNECTS, INTEGRATED CIRCUIT  
STRUCTURES, CIRCUITS, AND DATA  
APPARATUSES**

TECHNICAL FIELD

The technical field relates to communication methods, methods of forming an interconnect, signal interconnects, integrated circuit structures, circuits, and data apparatuses.

BACKGROUND

Designers aim to meet respective demands of a given implementation of a circuit. For example, in some implementations, an aim of a designer may be to provide interconnects of increased communications speeds capable of operating with associated electrical components, such as processors and memory, as the speeds of the respective components themselves continue to increase. Also, the amount of information needed to be communicated within a given circuit implementation may lead to circuit designs which utilize relatively high bandwidth interconnects. There is also a continuing desire in at least some applications for security of data communicated within a given circuit or between circuit components. In some arrangements, data content of information signals may be encrypted to provide increased security of the data content compared with unencrypted implementations.

BRIEF DESCRIPTION OF THE DRAWINGS

FIG. 1 is a functional block diagram of a data apparatus according to one embodiment.

FIG. 2 is an illustrative representation of an integrated circuit structure according to one embodiment.

FIG. 3 is an illustrative representation of a circuit including a signal interconnect according to one embodiment.

FIG. 4 is an illustrative representation of a circuit including a signal interconnect according to one embodiment.

FIG. 5 is an isometric view of an integrated circuit structure including a signal interconnect according to one embodiment.

FIG. 6 is a flow chart of a method of fabricating a signal interconnect according to one embodiment.

DETAILED DESCRIPTION OF THE  
ILLUSTRATED EMBODIMENTS

One embodiment of the invention comprises a signal interconnect configured to transmit different types or classes of electromagnetic signals. Some different types or classes of electromagnetic signals include electrical signals, optical signals, and plasmonic signals. In one embodiment, signals of the different types or classes may be multiplexed and concurrently transmitted using a waveguide of a signal interconnect. As described below, the signal interconnect may be used to transmit signals in different arrangements, for example, within or with respect to integrated circuitry and/or with respect to components of a data apparatus. Other embodiments of the disclosure are described below.

Referring to FIG. 1, a data apparatus of one embodiment is depicted with respect to reference 10. In the illustrated implementation, data apparatus 10 is an electrical device and includes one or more circuit components which individually include electrical circuitry (a plurality of circuit components 12, 14 are illustrated in the embodiment of FIG. 1). One or

2

both of circuit components 12, 14 may comprise an integrated circuit structure. For example, circuit components 12, 14 may individually include processing circuitry and/or storage circuitry in some embodiments as described in further detail below. The depicted data apparatus 10 additionally includes a signal interconnect 16 coupled to the circuit components 12, 14 to communicate signals therebetween and/or with respect to circuitry (not shown) external of data apparatus 10.

In more specific and non-limiting embodiments, data apparatus 10 is a computing device (e.g., personal computer, work station), electrical consumer device (e.g., telephone, personal digital assistant, digital camera, wireless device, display, chip set, set top box, game, vehicle, etc.), or control system. As noted, above-recited embodiments of data apparatus 10 are only illustrative and data apparatus 10 may be implemented in other embodiments which utilize electrical circuitry.

In one embodiment, processing circuitry is arranged to process data, control data access and storage, issue commands, and control other desired operations. Processing circuitry may comprise circuitry configured to implement desired programming provided by appropriate media in at least one embodiment. For example, the processing circuitry may be implemented as one or more of a processor and/or other structure configured to execute executable instructions including, for example, software and/or firmware instructions, and/or hardware circuitry. Embodiments of processing circuitry include hardware logic, PGA, FPGA, ASIC, state machines, and/or other structures alone or in combination with a processor. These embodiments of processing circuitry are for illustration and other configurations are possible.

The storage circuitry is configured to store programming such as executable code or instructions (e.g., software and/or firmware), electronic data, databases, or other digital information and may include processor-usable media. Processor-usable media may be embodied in any computer program product(s) or article of manufacture(s) which can contain, store, or maintain programming, data and/or digital information for use by Pr in connection with an instruction execution system including processing circuitry in the exemplary embodiment. For example, suitable processor-usable media may include any one of physical media such as electronic, magnetic, optical, electromagnetic, infrared or semiconductor media. Some more specific embodiments of processor-usable media include, but are not limited to, a portable magnetic computer diskette, such as a floppy diskette, zip disk, hard drive, random access memory, read only memory, flash memory, cache memory, and/or other configurations capable of storing programming, data, or other digital information.

As mentioned above, one embodiment of the disclosure comprises multiplexing of a plurality of signals and communicating the multiplexed signals using a signal interconnect. In one embodiment, one of the circuit components 12, 14 of the data apparatus 10 comprises an information source (e.g., processing circuitry, storage circuitry) configured to provide data content of one or more of the signals to be communicated, and the signal interconnect is configured to communicate signals comprising the data content to locations remote from the source of the data content. The signal interconnect configured to communicate multiplexed signals may be implemented as signal interconnect 16, signal interconnects within one or more of circuit components 12, 14 (e.g., signal interconnects 24, 24a described below), combinations of signal interconnect 16 and signal interconnects of components 12, 14, or in other arrangements in other embodiments. One type of signal interconnect which may transmit multiplexed signals includes a signal interconnect of integrated circuitry

(e.g., integrated circuitry of one or both of circuit components **12**, **14**) as described with respect to FIG. **2** in one embodiment.

Referring to FIG. **2**, an integrated circuit structure **20** is shown. The depicted integrated circuit structure **20** may be a semiconductor die, vertically integrated multichip package (MCP), stacked or other arrangement of integrated circuitry in various embodiments. As mentioned above, one or both of circuit components **12**, **14** may comprise an integrated circuit structure **20**.

The depicted integrated circuit structure **20** is described with respect to a chip having a periphery **28** (e.g., periphery **28** corresponds to a footprint of structure **20** in the embodiment of FIG. **2**). Structure **20** includes a plurality of circuits **21**, **21a**, for discussion purposes. More specifically, circuits **21**, **21a** individually include respective integrated circuit portions **22** and respective signal interconnects **24**, **24a**. In one embodiment of structure **20**, one or both of signal interconnects **24**, **24a** are implemented as integrated circuitry of the structure **20**. In other embodiments, only portions or neither of signal interconnects **24**, **24a** are implemented as integrated circuitry. In addition, the signal interconnects **24**, **24a** may be individually connected with one or more of the integrated circuit portions **22** of structure **20**. In the specific example of FIG. **2**, signal interconnect **24** is connected with respective plural portions **22** of structure **22** via respective connections **26** (e.g., a single one of connections **26** may include optical and electrical contacts) contacting the signal interconnect **24** while signal interconnect **24a** connects a single integrated circuit portion **22** via a respective connection **26** with circuitry external of structure **20** (the external circuitry is not shown in FIG. **2**). Optical and electrical contacts of a connection **26** may be referred to as optical and electrical interfaces, respectively.

Signal interconnect **24** connects different integrated circuit portions **22** provided at different spatial locations of structure **20** while interconnect **24a** connects respective integrated circuitry **22** provided at a first spatial location with another spatial location located at the periphery **28** of structure **20** as well as external circuitry located at yet a different spatial location. In FIG. **2**, signal interconnect **24** may be referred to as an on-chip signal interconnect while signal interconnect **24a** may be referred to as an off-chip signal interconnect. In other embodiments, one or both of signal interconnects **24**, **24a** may not be connected with integrated circuitry of structure **20**.

Signal interconnects **24**, **24a** are individually configured to concurrently communicate optical and electrical information signals in one embodiment. In one embodiment, integrated circuit portions **22** may include source circuitry in the form of an optical source (e.g., optical modulator) and/or electrical source (e.g., processing circuitry, memory, buffers, communications interfaces, etc.) configured to generate or otherwise provide optical and electrical information signals, respectively, and which may be communicated via a respective signal interconnect **24**, **24a**. Integrated circuit portions **22** may include recipient circuitry configured to process optical and electrical information signals received by a respective signal interconnect **24**, **24a**.

According to one embodiment, filtering of optical information signals may be provided. For example, a filter may control the transmission of at least one wavelength of electromagnetic energy. Filtering of optical signals may be implemented in various embodiments. An embodiment of a filter may include photonic crystals as described in U.S. Patent Publication No. 2005/0263675 A1, published Dec. 1, 2005; U.S. Patent Publication No. 2005/0281524 A1, published

Dec. 22, 2005; U.S. Patent Publication No. 2006/0006485 A1, published Jan. 12, 2006; U.S. Patent Publication No. 2006/0186318, published Aug. 24, 2006; and U.S. Patent Publication No. 2006/0186319 A1, published Aug. 24, 2006, the teachings of which are incorporated herein by reference. One or more filters may be formed using one or more of the integrated circuit portions **22** coupled with respective signal interconnects **24**, **24a** in one embodiment. Photonic crystals may be made of metal oxides using conventional semiconductor processing techniques in one embodiment. Filters including photonic crystals made of metal oxides may transmit electrical signals as well as optical signals.

Referring to FIG. **3**, one example of a circuit **30** is shown. The circuit **30** may be part of an integrated circuit structure **20** in some embodiments. The circuit **30** shown in FIG. **3** includes signal interconnect **24** coupled with plural interfaces **32**, **34** for communicating a plurality of information signals. For example, interface **32** may be an optical contact configured to communicate optical information signals with respect to circuitry external of circuit **30** (the external circuitry is not shown in FIG. **3**). The interface **32** configured as an optical interface may be used for an optical interface to communicate signals with respect to an optical modulator or optical demodulator in illustrative configurations. For example, one optical modulator may be implemented as a high-speed optical modulator using silicon technology based on a MOS capacitor as described in Ansheng Liu et al., "A High-Speed Silicon Optical Modulator Based On A Metal-Oxide-Semiconductor Capacitor," *Nature*, Vol. 427 Feb. 12, 2004, incorporated herein by reference. Other optical modulator configurations may be used in other embodiments. In one embodiment, one of integrated circuit portions **22** may be configured as such an optical modulator. Additionally, a polarized filter may be coupled with optical interface **32** to provide signal selection.

Furthermore, interface **34** of circuit **30** may be an electrical interface configured to communicate electrical information signals with respect to circuitry external of circuit **30**. Electrical interface **34** may be an electrical contact which may be connected to a wire, metallization or other conductive structure external of circuit **30** in possible implementations.

The signal interconnect **24** includes a transmission medium configured to communicate optical and electrical information signals. The transmission medium forms a waveguide **36** for multiplexed optical and electrical signal transmission in the described embodiment. The transmission medium of signal interconnect **24** may comprise a material which transmits photons and also conducts electrical data carriers (e.g., electrons or holes) in one embodiment. The material may be a metal oxide, such as indium tin oxide, zinc tin oxide, etc., in various embodiments.

Circuit **30** operates as a multiplexer to concurrently communicate the optical and electrical signals with respect to respective interfaces **32**, **34** in one embodiment. Additional interfaces (e.g., optical and electrical interfaces not shown in FIG. **3**) may be spatially located from the depicted interfaces **32**, **34** and, for example, coupled with a portion of interconnect **24** which extends in a rightward direction in FIG. **3**. The transmission medium transmits optical information signals and electrical information signals between spatially located optical and electrical interfaces, respectively, in the described embodiment.

Referring to FIG. **4**, another circuit **30a** is shown for communicating optical and electrical signals. The circuit **30a** includes signal interconnect **24** in the form of a single interconnect line coupled with an optical interconnect line **42** and a plurality of electrical interconnect lines **43**, **44**. In the

## 5

depicted embodiment, signal interconnect **24** is configured to communicate optical signals between optical interface **32** and an optical interface coupled with optical interconnect line **42** at a spatial location **45** while concurrently communicating electrical information signals intermediate electrical inter-  
 5 faces coupled with electrical interconnect lines **43, 44** (and also located at different spatial locations **46, 48**). In one embodiment, electrical interconnect lines **44** may be referred to as input lines which may individually correspond to one of a plurality of differently encoding schemes, for example, which may be used to encode data content of an optical information signal. Additional encoding details are described below.

Referring to FIG. **5**, additional details regarding one embodiment of signal interconnect **24** formed as integrated circuitry are shown. The illustrated signal interconnect **24** is fabricated using a substrate **50** of an integrated circuit structure **22** in the depicted embodiment. The substrate **50** may comprise a semiconductive material, such as silicon, in one embodiment. Other substrate materials may be used in other configurations.

A trench **51** has been formed within substrate **50** in the depicted embodiment. A transmission medium **52** of the signal interconnect **24** is formed within trench **51** forming a damascene or buried interconnect line in one possible arrangement. The transmission medium **52** may be a material which is substantially transparent to light while also being electrically conductive. According to certain embodiments mentioned above, the transmission medium **52** may be a metal oxide configured to conduct electrical data carriers and transmit photons.

Barrier material **54** may be provided between the sides and bottom of transmission medium **52** and the substrate **50** in one implementation. Barrier material **54** may be a high-k electrically insulative material to provide electrical insulation of electrical information signals conducted by transmission medium **52**. In addition, barrier material **54** may have a refractive index different than a refractive index of the transmission medium **52** to provide optical insulation of optical information signals communicated by transmission medium **52**. Barrier material **54** may be silicon nitride in one embodiment. Insulative material **56** may be provided over transmission medium **52** of signal interconnect **24** and perhaps other portions of substrate **50** to further electrically and optically insulate transmission medium **52** in one embodiment. The insulated transmission medium **52** provides a waveguide **36** configured to simultaneously transmit multiplexed electrical and optical information signals and which is optically and electrically insulated from neighboring interconnects (not shown) in the illustrated embodiment.

In the embodiment depicted in FIG. **5**, transmission medium **52** is a single monolithic material configured to simultaneously communicate a plurality of information signals including optical and electrical signals in one implementation. The transmission medium **52** has a cross-sectional area as shown in FIG. **5** and which may simultaneously pass the optical and electrical information signals.

Referring to FIG. **6**, an embodiment of a process is shown for fabricating the embodiment of the signal interconnect **24** depicted in FIG. **5**. Other methods of fabrication are contemplated including more, less and/or alternative acts.

At an act **S10**, a trench may be formed within a substrate, such as silicon. In one embodiment, photolithography may be used to form the trench. The trench may be formed between a plurality of spaced spatial locations to be interconnected by the signal interconnect in one embodiment.

## 6

At an act **S12**, optically and electrically insulative material may be deposited within the trench. In one embodiment, a low temperature (e.g., 200-750 C) PCVD process may be used to deposit a silicon nitride film. The deposition provides silicon nitride on the lower surface and sidewalls of the trench in one embodiment.

At an act **S14**, the material of the transmission medium providing a waveguide may be deposited within the trench after the formation of the silicon nitride upon the bottom surface and side walls of the trench. One suitable material includes a metal oxide as mentioned above. In addition, the metal oxide may be SnO<sub>2</sub> doped in one embodiment to increase electrical conductivity of the transmission medium. In addition, graded index optimization of the transmission medium may be performed for improved transmission characteristics at interfaces and/or to reduce dispersion losses in optical signals. In one example, material of a graded index transmission medium has a refractive index tuned in such a manner that it decreases with increasing distance from a center of the material. In such case, a central portion of the medium has a higher refractive index than outer portions of the medium and light is generally confined to the central portion of the medium which drastically reduces dispersion losses. In one embodiment, a graded index transmission medium may be formed by depositing multiple layers of dielectric with different stoichiometry (composition of elements) thus altering the refractive index.

At an act **S16**, insulative material may be deposited over the trench and the substrate to encapsulate the formed signal interconnect structure. The insulative material, such as silicon nitride, may provide optical and electrical insulation in one embodiment. Portions of the insulative material over the transmission medium may be patterned and removed to provide electrical and/or optical communication of the signal interconnect with respect to electrical or optical interfaces.

As described above, signal interconnects are described which are configured to communicate a plurality of information signals. For example, as discussed above, optical and electrical signals may be multiplexed and concurrently communicated using a common signal interconnect. According to one embodiment, one of the multiplexed signals may include information regarding another of the multiplexed signals.

In a more specific embodiment, data content of a first of the information signals (e.g., optical information signal) may be encoded or encrypted. A second of the information signals (e.g., electrical information signal) may include information regarding a scheme used to encode or encrypt respective data content of the first information signal and/or information regarding optical modulation of the first information signal and which may be used to decode, demodulate and/or decrypt data content of the first of the information signals in one specific embodiment. In addition, encoding or encryption may change in real time, "on the fly." The second information signal may provide encoding or encryption information in real time and indicate changes in encoding or encryption of the data content at different moments in time according to changes in the encoding or encryption of respective portions of the data content. In one embodiment, an encoder may be configured as a source to generate the electrical signal which includes information regarding the encoding or encryption of data content of the optical signal which may be generated by a respective different source (e.g., data content may be generated by processing circuitry).

Optical interconnects provide advantages for data or signal transmission. For example, photons do not suffer from R, C parasitics and provide wider bandwidth compared with electrons. The interconnects may be used for on-chip signal trans-



mission, off-chip signal transmission between different IC dies, and/or signal transmission in vertically integrated multi-chip packages (MCPs) in illustrative implementations. At least some of the signal interconnects described herein provide relatively wide bandwidth and relatively high signal/noise ratios (e.g., it is believed that signal/noise ratios in excess of 80% may be achieved in certain embodiments). Further, at least some of the signal interconnects may be implemented using conventional CMOS technologies.

Some embodiments have been described herein with respect to optical and electrical signals. The optical signals and electrical signals use different classes of data carriers to transmit information in the described embodiment. The different classes of data carriers correspond to different types of particles or waves corresponding to different portions of the electromagnetic spectrum. For example, in one embodiment using optical and electrical signals, the data carriers include photons and electrons (or holes), respectively. Other signals may be utilized in other embodiments. For example, one of the information signals may be a plasmonic wave utilizing data carriers in the form of plasmons to transmit information. Some arrangements using plasmonic waves utilize localized surface plasmonic resonance (LSPR) comprising plasmon resonance in nanoscale metallic surfaces or Surface Plasmon Resonance (SPR) comprising plasmon resonance in planar surfaces of relatively larger areas.

In compliance with the statute, the subject matter disclosed herein has been described in language more or less specific as to structural and methodical features. It is to be understood, however, that the claims are not limited to the specific features shown and described, since the means herein disclosed comprise only some of the various contemplated embodiments. The claims are thus to be afforded full scope as literally worded, and to be appropriately interpreted in accordance with the doctrine of equivalents.

Further, details herein have been presented for guidance in construction and/or operation of the disclosed embodiments. Applicant(s) hereof consider these described embodiments to also include, disclose and describe further arrangements or embodiments in addition to those explicitly disclosed. For example, the additional embodiments may include less, more and/or alternative features than those described in the specifically described embodiments. More specifically, Applicants consider the disclosure to include, disclose and describe methods which include less, more and/or alternative acts than those methods explicitly disclosed as well as apparatus which includes less, more and/or alternative structure than the explicitly disclosed structures.

I claim:

1. A communication method comprising:
  - accessing an optical signal comprising photons to communicate information;
  - accessing an electrical signal comprising electrical data carriers to communicate information; and
  - using a single transmission construction of an interconnect, communicating the photons of the optical signal and the electrical data carriers of the electrical signal between a first spatial location and a second spatial location spaced from the first spatial location.
2. The method of claim 1 wherein the communicating comprises simultaneously communicating the optical and electrical signals using the single transmission construction.
3. The method of claim 1 wherein the communicating comprises passing the optical and electrical signals through a monolithic material of the single transmission construction.

4. The method of claim 3 wherein the passing comprises passing the optical and electrical signals through the monolithic material comprising a metal oxide.

5. The method of claim 1 wherein the communicating comprises communicating the optical and electrical signals between a plurality of different spaced spatial locations of an integrated circuit structure using the single transmission construction.

6. The method of claim 5 further comprising providing the optical signal and providing the electrical signal using integrated circuitry of the integrated circuit structure.

7. The method of claim 1 further comprising filtering the optical signals.

8. A communication method comprising:
 

- providing an optical information signal comprising a plurality of photons;
- providing an electrical information signal comprising a plurality of electrical data carriers;
- multiplexing the optical information signal and the electrical information signal; and
- communicating the multiplexed optical information signal and electrical information signal.

9. The method of claim 8 wherein the communicating comprises communicating the multiplexed optical information signal and electrical information signal using a single interconnect.

10. The method of claim 8 wherein the communicating comprises communicating the multiplexed optical information signal and electrical information signal using a single interconnect, wherein the single interconnect comprises a metal oxide.

11. The method of claim 8 wherein the communicating comprises communicating the multiplexed optical information signal and electrical information signal using a monolithic transmission medium.

12. A communication method comprising:
 

- providing an electrical information signal using circuitry of an integrated circuit structure;
- providing an optical information signal using circuitry of an integrated circuit structure; and
- communicating electrical data carriers of the electrical information signal and photons of the optical information signal using a single waveguide of an interconnect of the integrated circuit structure, wherein the communicating comprises communicating the electrical information signal and the optical information signal between a plurality of different spatial locations within a periphery of the integrated circuit structure using the single waveguide of the interconnect.

13. The method of claim 12 wherein the communicating comprises simultaneously communicating the photons of the optical information signal and the electrical data carriers of the electrical information signal using the single waveguide of the interconnect.

14. The method of claim 12 wherein the communicating comprises communicating one of the optical information signal and the electrical information signal with respect to a connection positioned at one of the different spatial locations, and wherein the connection is connected with integrated circuitry of the integrated circuit structure.

15. The method of claim 14 wherein the communicating comprises communicating the one of the optical information signal and the electrical information signal with respect to another of the different spatial locations located at the periphery of the integrated circuit structure and coupled with circuitry external of the periphery of the integrated circuit structure.

16. The method of claim 12 wherein the communicating comprises communicating using the single waveguide of the interconnect formed using a substrate of the integrated circuit structure.

17. The method of claim 12 wherein the communicating comprises communicating using monolithic material of the single waveguide of the interconnect.

18. The method of claim 12 wherein the communicating comprises communicating the photons of the optical information signal and the electrical data carriers of the electrical information signal using a metal oxide of the single waveguide of the interconnect.

19. A communication method comprising:

accessing a first signal comprising encoded data content; accessing a second signal comprising information regarding at least one aspect of encoding of the encoded data content; and

concurrently communicating the first signal and the second signal using a single interconnect.

20. A communication method comprising simultaneously communicating multiplexed electrical and optical signals using a single interconnect.

21. The method of claim 20 wherein the communicating comprises communicating using a monolithic transmission medium of the single interconnect comprising a metal oxide.

22. A method of forming an interconnect comprising:

providing a waveguide associated with a substrate, wherein a monolithic transmission medium of the waveguide comprises a metal oxide configured to transmit photons and to conduct electrical data carriers;

electrically insulating the waveguide from the substrate; and

optically insulating the waveguide from the substrate.

23. A signal interconnect comprising:

a transmission medium configured to concurrently transmit a plurality of information signals between a first spatial location and a second spatial location which is spaced from the first spatial location, wherein the plurality of information signals comprise respective different classes of data carriers for communicating respective information of the respective information signals and wherein one of the classes of the data carriers comprises photons.

24. A circuit comprising:

a plurality of spaced optical interfaces;

a plurality of spaced electrical interfaces; and

a transmission medium coupled with the optical interfaces and the electrical interfaces and configured to concurrently transmit an optical information signal comprising a plurality of photons between the plurality of optical interfaces and an electrical information signal comprising a plurality of electrical data carriers between the plurality of electrical interfaces.

25. An integrated circuit structure comprising:

a substrate; and

a transmission medium coupled with the substrate and configured to concurrently transmit a plurality of different information signals between different spatial locations of the substrate, wherein one of the different information signals comprises an optical signal which includes photons and another of the different information signals comprises an electrical signal.

26. A circuit comprising:

an optical source configured to provide optical signals comprising photons to transmit information;

an electrical source configured to provide electrical signals comprising electrical data carriers to transmit information; and

a waveguide coupled with the optical source and the electrical source and configured to receive the optical signals and the electrical signals from the optical source and the electrical source and to transmit photons of the optical signals and electrical data carriers of the electrical signals to a location remote from locations of the optical source and the electrical source.

27. A circuit comprising:

a first information source configured to provide first signals comprising data content;

a second information source configured to provide second signals comprising information regarding the first signals; and

a signal interconnect coupled with the first information source and the second information source and configured to transmit the first signals and the second signals.

28. A circuit comprising:

a signal interconnect configured to multiplex an optical information signal and electrical information signal and to transmit the multiplexed optical and electrical information signals from a first spatial location to a second spatial location spaced from the first spatial location.

29. The circuit of claim 28 wherein the interconnect comprises a metal oxide.

30. A data apparatus comprising:

an information source configured to provide information to be communicated;

a waveguide coupled with the information source and configured to transmit a first information signal comprising the information from the information source to a location remote from the information source;

wherein the waveguide is configured to transmit a second information signal concurrently with the transmission of the first information signal, the second information signal comprising respective information different than the information of the first information signal; and

wherein one of the first and second information signals comprises photons of an optical signal and an other of the first and second information signals comprises an electrical signal.

31. The method of claim 1 wherein the single transmission construction is a waveguide.

32. The method of claim 19 wherein the accessing the first signal comprising encoded data content comprises accessing the first signal comprising encrypted data content, and the accessing the second signal comprises accessing the second signal comprising information regarding the encryption of the data content.

33. The method of claim 32 wherein the encrypted data content of the first signal comprises data content which is encrypted using different encryption at different moments in time, and the accessing the second signal comprises accessing the second signal indicating changes of the encryption.

34. The interconnect of claim 23 wherein the transmission medium comprises a single waveguide configured to concurrently transmit the plural information signals comprising respective different classes of data carriers.

35. The interconnect of claim 23 wherein one of the information signals comprises an electrical signal having respective data carriers comprising at least one of electrons and holes and the other of the information signals comprises an optical signal having respective data carriers comprising the photons.

## 11

36. The interconnect of claim 23 wherein one of the information signals comprises a plasmonic wave having respective data carriers comprising plasmons.

37. The interconnect of claim 23 wherein the transmission medium comprises a cross-sectional area configured to simultaneously pass the data carriers of the plurality of information signals.

38. The interconnect of claim 23 wherein the transmission medium comprises a single monolithic material configured to simultaneously communicate the data carriers of the plurality of information signals.

39. The interconnect of claim 23 wherein one of the information signals comprises information regarding another of the information signals.

40. The interconnect of claim 23 wherein the transmission medium comprises a metal oxide.

41. The circuit of claim 24 wherein the transmission medium is configured to multiplex the optical information signal and the electrical information signal.

42. The circuit of claim 24 wherein the transmission medium comprises a single monolithic material configured to simultaneously communicate the optical information signal and the electrical information signal.

43. The circuit of claim 24 wherein one of the optical and electrical information signals comprises information regarding another of the optical and electrical information signals.

## 12

44. The structure of claim 25 wherein the transmission medium comprises a single waveguide configured to concurrently transmit the optical signal and the electrical signal.

45. The circuit of claim 26 wherein the waveguide comprises a single monolithic material configured to simultaneously communicate the optical and electrical signals.

46. The circuit of claim 27 wherein the first signals comprise encoded data content, and the second signals comprise information regarding encoding of the encoded data content.

47. The circuit of claim 46 wherein the encoded data content of the first signals comprises encrypted data content, and the second signals comprise information regarding encryption of the encrypted data content.

48. The circuit of claim 27 wherein the first signals comprise data content encoded differently at different moments in time, and the second signals comprise information regarding the different encodings of the data content at the different moments in time.

49. The method of claim 20 wherein the communicating comprises communicating electrical data carriers of the electrical signal and photons of the optical signal.

50. The circuit of claim 28 wherein the signal interconnect is configured to transmit photons and electrical data carriers of the multiplexed optical and electrical information signals.

\* \* \* \* \*