



US007840246B1

(12) **United States Patent**
Poore

(10) **Patent No.:** **US 7,840,246 B1**
(45) **Date of Patent:** **Nov. 23, 2010**

(54) **IMPLANTABLE SELF-CALIBRATING OPTICAL SENSORS**

(75) Inventor: **John W. Poore**, South Pasadena, CA (US)

(73) Assignee: **Pacesetter, Inc.**, Sylmar, CA (US)

(*) Notice: Subject to any disclaimer, the term of this patent is extended or adjusted under 35 U.S.C. 154(b) by 1298 days.

6,289,229 B1	9/2001	Crowley	
6,330,464 B1 *	12/2001	Colvin et al.	600/316
6,491,639 B1	12/2002	Turcott	600/508
6,526,298 B1 *	2/2003	Khalil et al.	600/310
6,561,984 B1	5/2003	Turcott	600/485
6,567,678 B1	5/2003	Oosta et al.	
6,662,031 B1 *	12/2003	Khalil et al.	600/322
6,731,967 B1	5/2004	Turcott	600/407

(21) Appl. No.: **11/282,198**

(Continued)

(22) Filed: **Nov. 17, 2005**

OTHER PUBLICATIONS

Related U.S. Application Data

(63) Continuation-in-part of application No. 11/231,555, filed on Sep. 20, 2005.

Gene A. Bornzin et al., "Measuring Oxygen Saturation and Hematocrit Using a Fiberoptic Catheter" *IEEE/9TH Annual Conf. of Eng. & Biol. Soc.*, 1987; pp. 0807-0809.

(51) **Int. Cl.**
A61B 5/1455 (2006.01)

Primary Examiner—Eric F Winakur

(52) **U.S. Cl.** **600/339; 600/341**

(57) **ABSTRACT**

(58) **Field of Classification Search** 600/309–344
See application file for complete search history.

(56) **References Cited**

U.S. PATENT DOCUMENTS

3,847,483 A	11/1974	Shaw et al.	356/41
4,114,604 A	9/1978	Shaw et al.	128/2 L
4,686,988 A	8/1987	Sholder	128/419 PT
4,708,142 A	11/1987	DeCote, Jr.	128/419 PT
4,712,555 A	12/1987	Thornander et al.	128/419 PG
4,729,376 A	3/1988	DeCote, Jr.	128/419 PT
4,788,980 A	12/1988	Mann et al.	128/419 PG
4,809,697 A	3/1989	Causey, III et al.	128/419 PT
4,815,469 A *	3/1989	Cohen et al.	600/333
4,940,052 A	7/1990	Mann et al.	128/419 PG
4,944,298 A	7/1990	Sholder	128/419 PG
4,944,299 A	7/1990	Silvian	128/419 PG
4,969,467 A	11/1990	Callaghan et al.	128/419 PG
5,350,410 A	9/1994	Kleks et al.	607/28
5,553,615 A	9/1996	Carim et al.	128/633
5,608,207 A *	3/1997	Allen et al.	250/214 AG
6,275,734 B1	8/2001	McClure et al.	607/27

A measurement light detector detects light transmitted by a light source of an implantable system that is scattered back into an implantable housing, and produces a measurement signal indicative of the intensity of the light detected by the measurement light detector. A calibration light detector detects a portion of the transmitted light that has not exited the housing, and produces a calibration signal that is indicative of the intensity of the light detected by the calibration light detector, which is indicative of the intensity of the light transmitted by the light source. Changes in the intensity of the transmitted light are compensated for based on the calibration signal produced by the calibration light detector. This description is not intended to be a complete description of, or limit the scope of, the invention. Other features, aspects, and objects of the invention can be obtained from a review of the specification, the figures, and the claims.

21 Claims, 14 Drawing Sheets

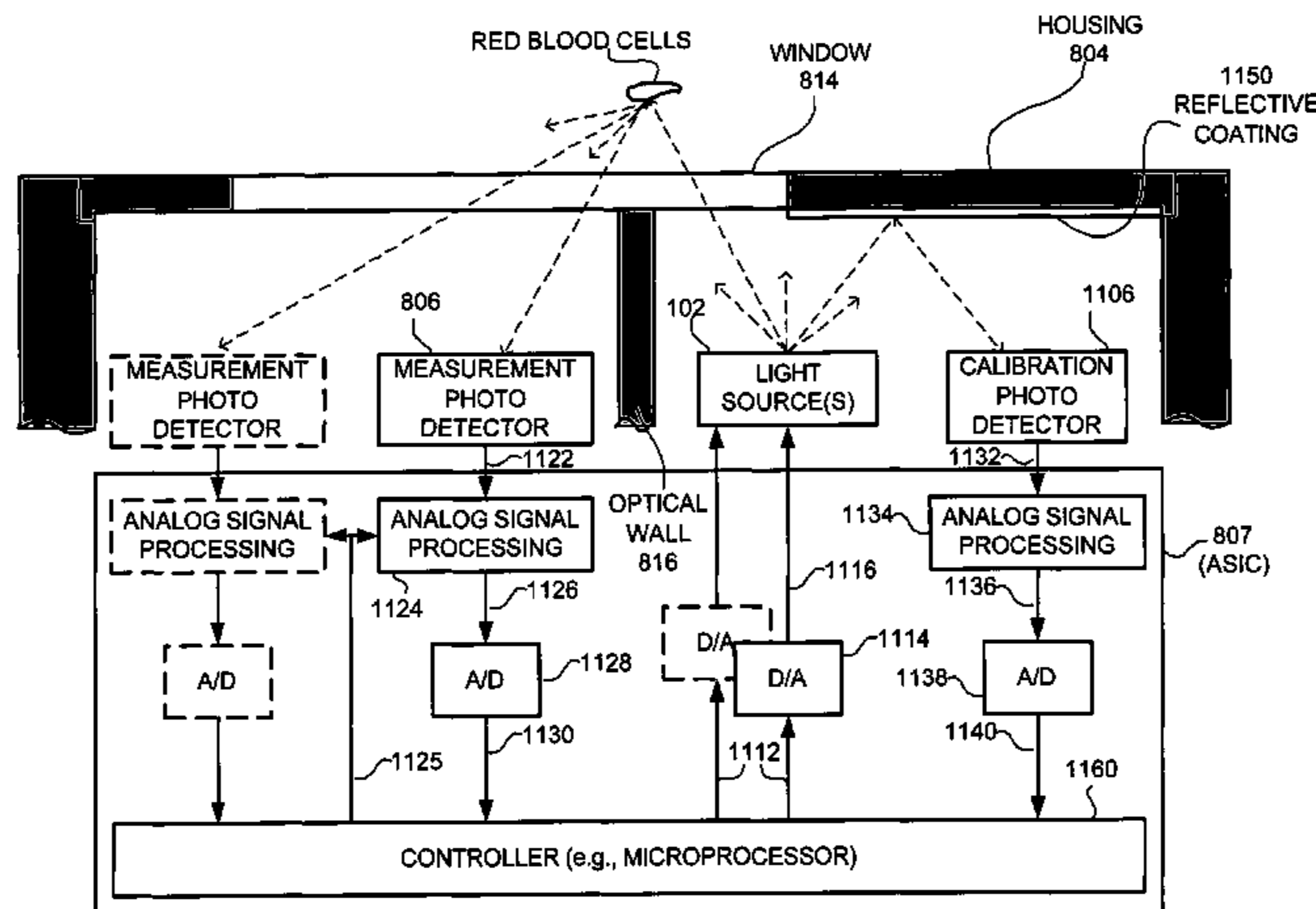

US 7,840,246 B1

Page 2

U.S. PATENT DOCUMENTS			
7,146,203	B2 *	12/2006	Botvinick et al. 600/345
7,230,222	B2 *	6/2007	Cheng et al. 250/205
2002/0026106	A1	2/2002	Khalil et al.
2004/0242980	A1 *	12/2004	Kiani et al. 600/323
2005/0027178	A1	2/2005	Iddan
2007/0060811	A1	3/2007	Roberts

* cited by examiner

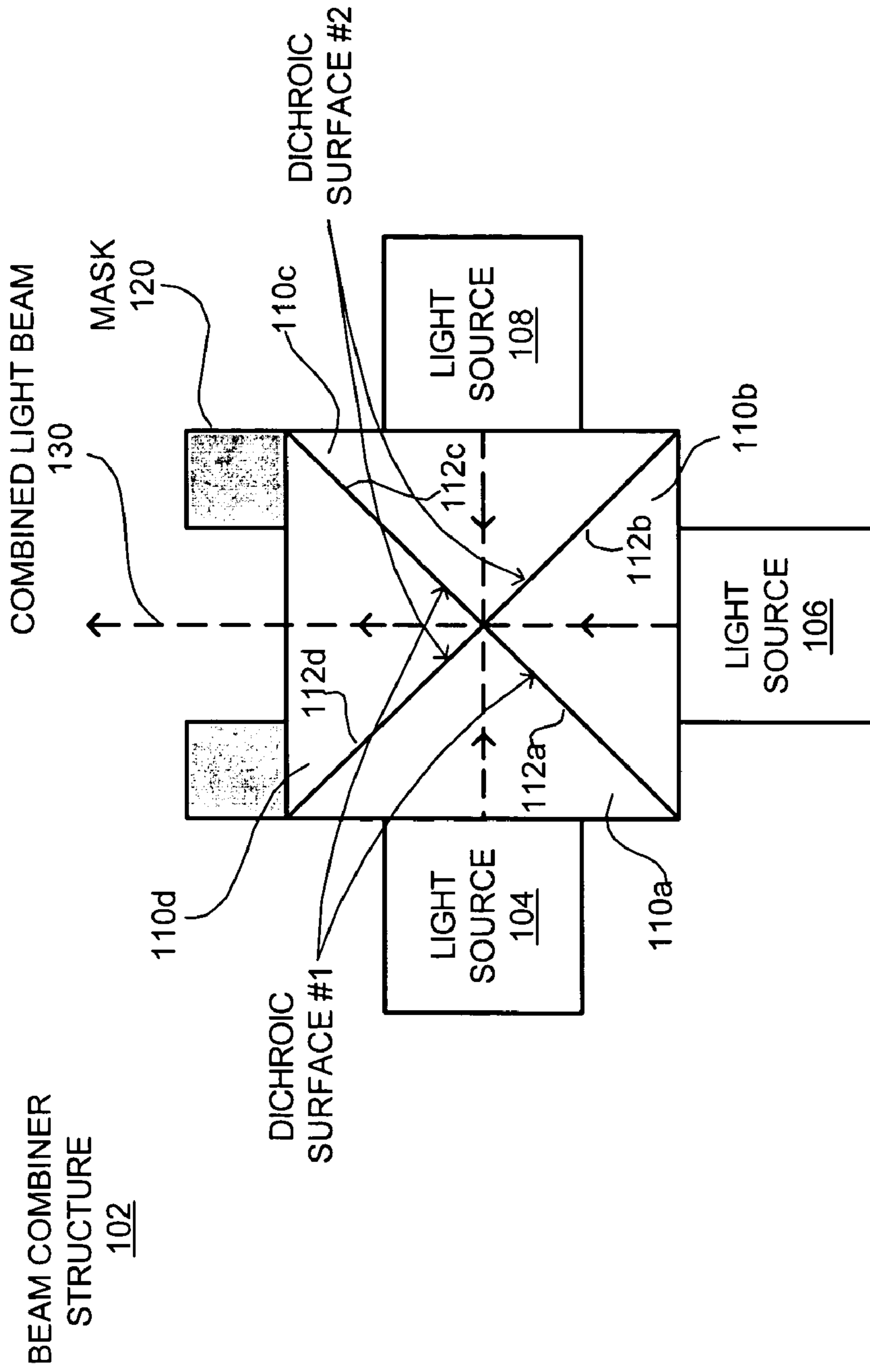

FIG. 1

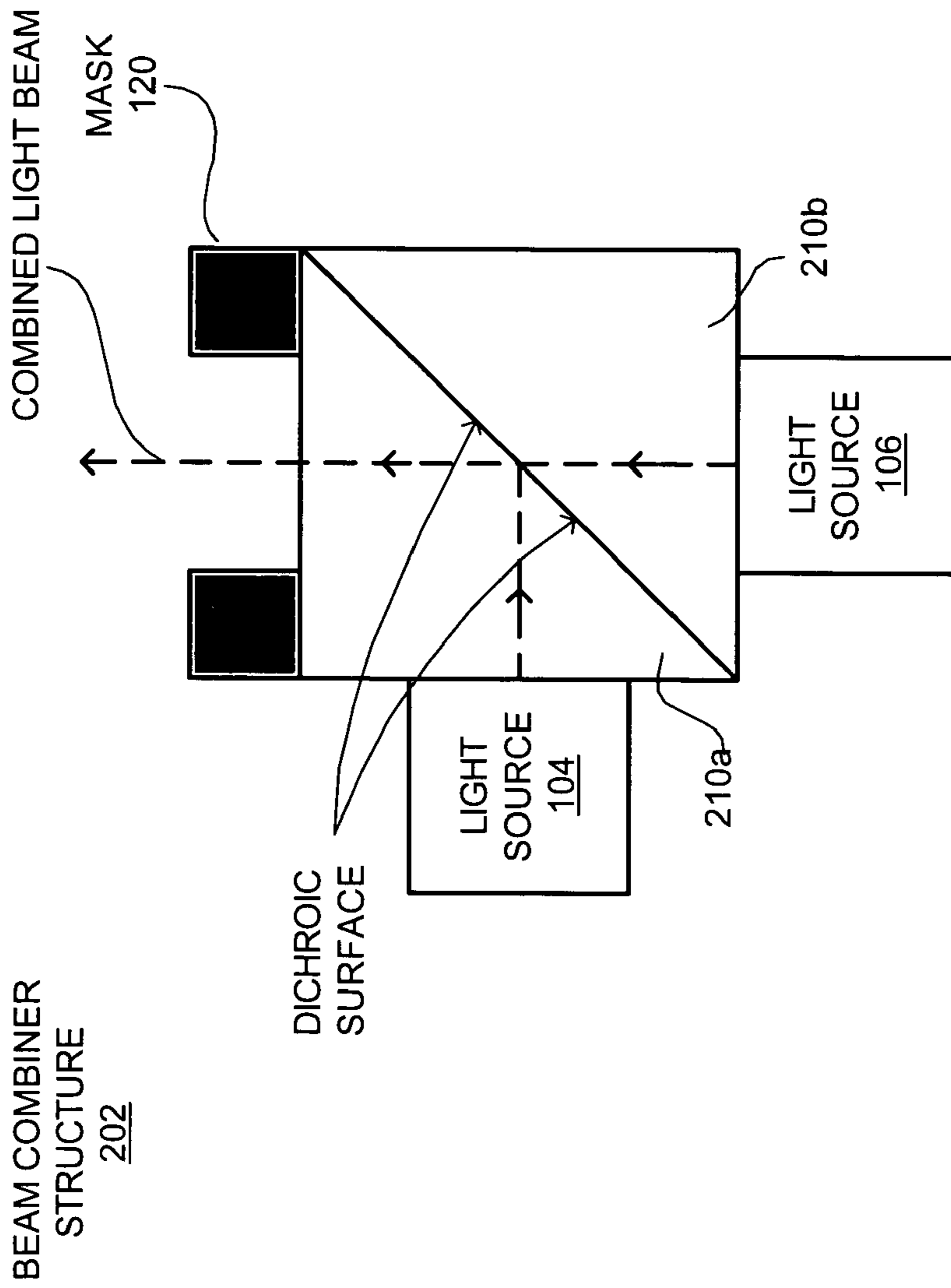

FIG. 2

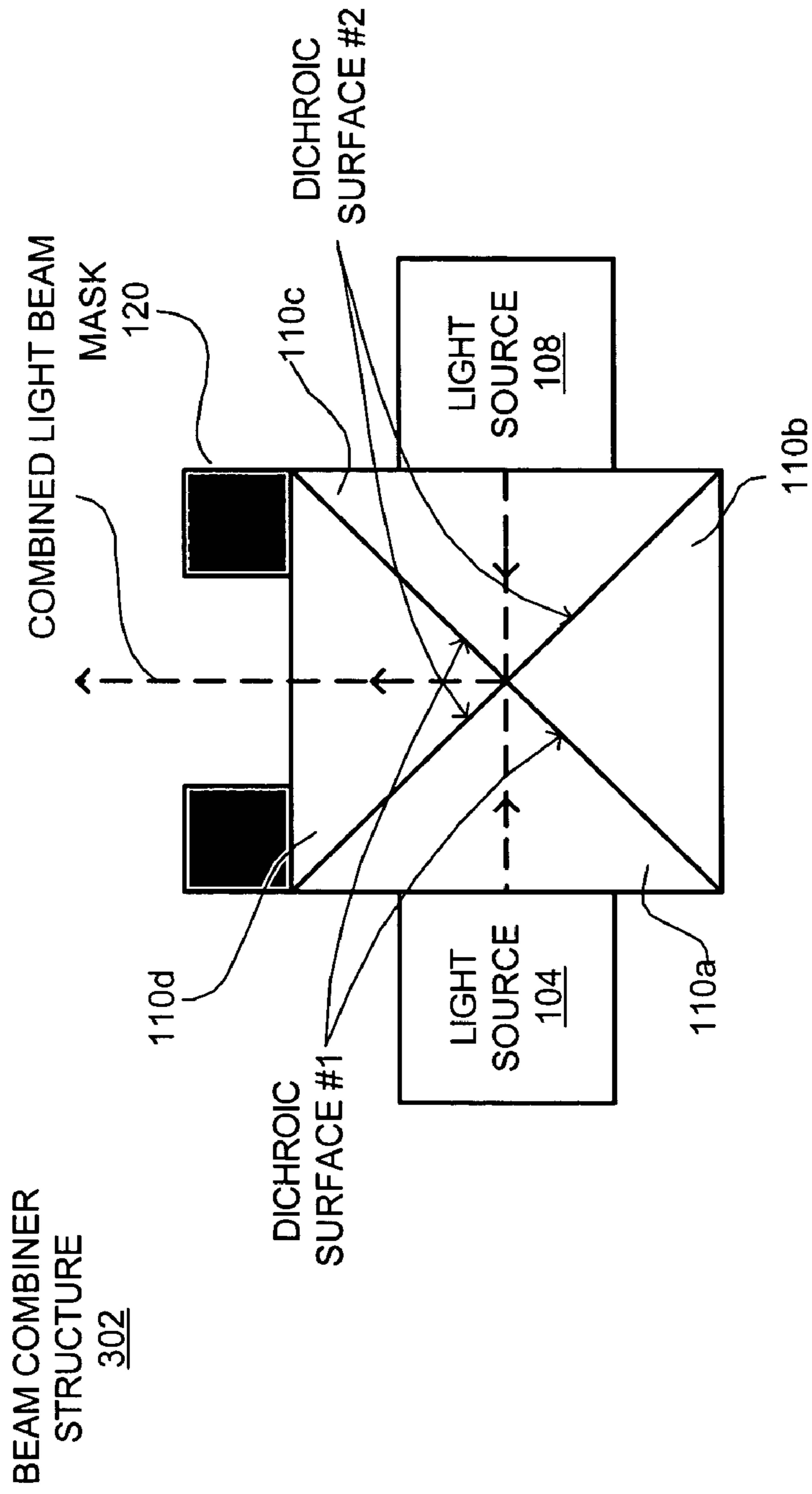

FIG. 3

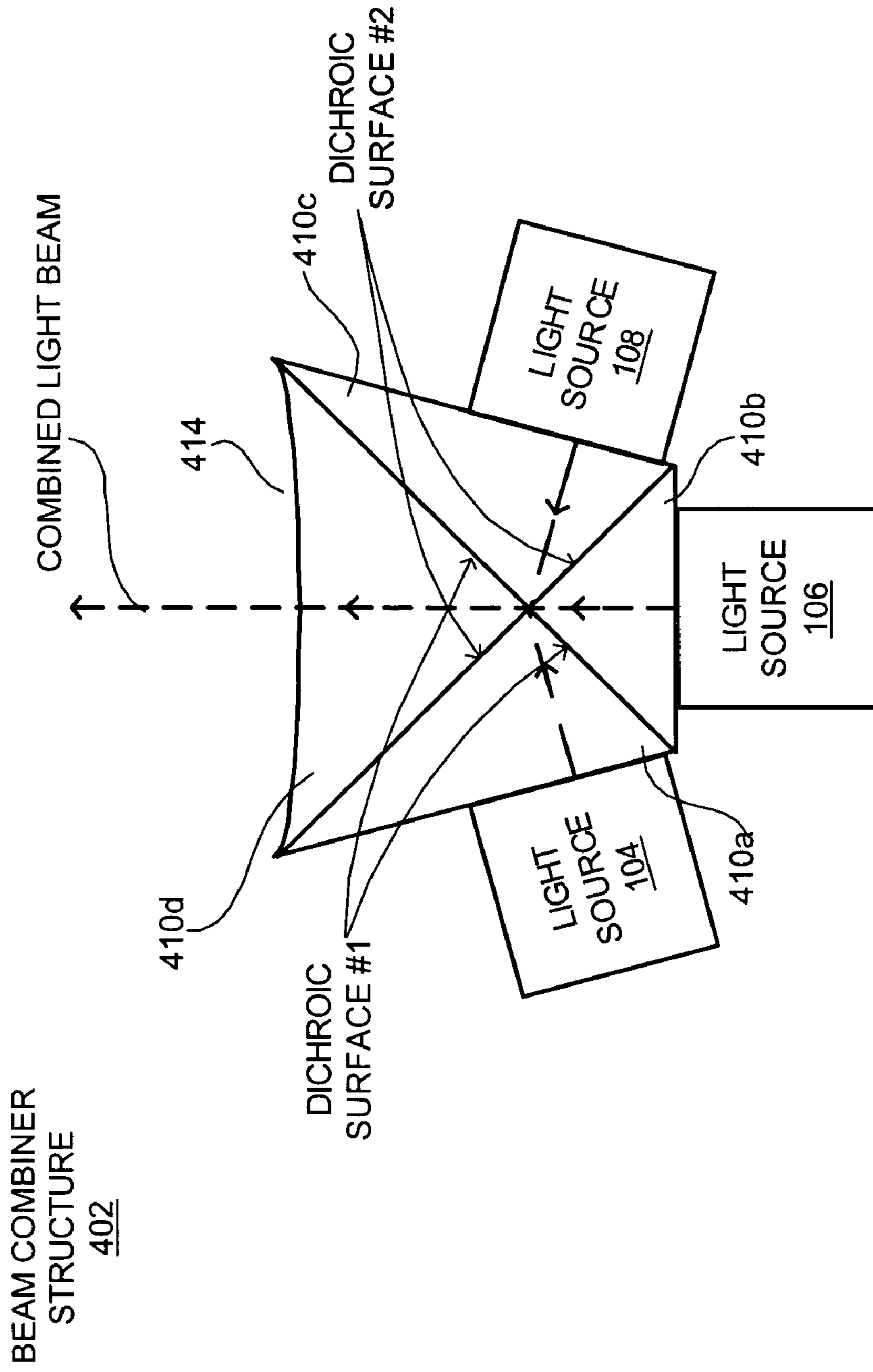

FIG. 4

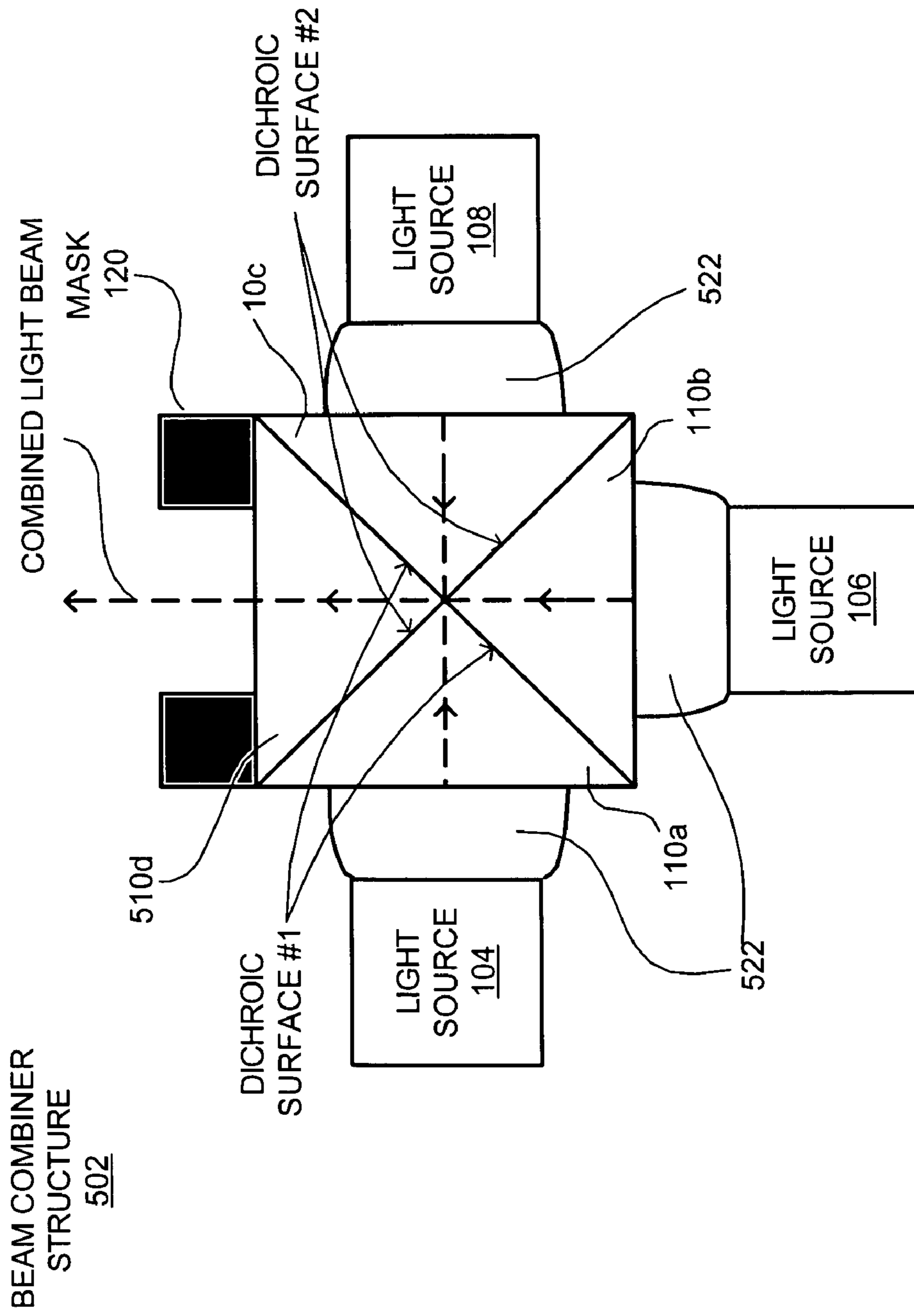

FIG. 5

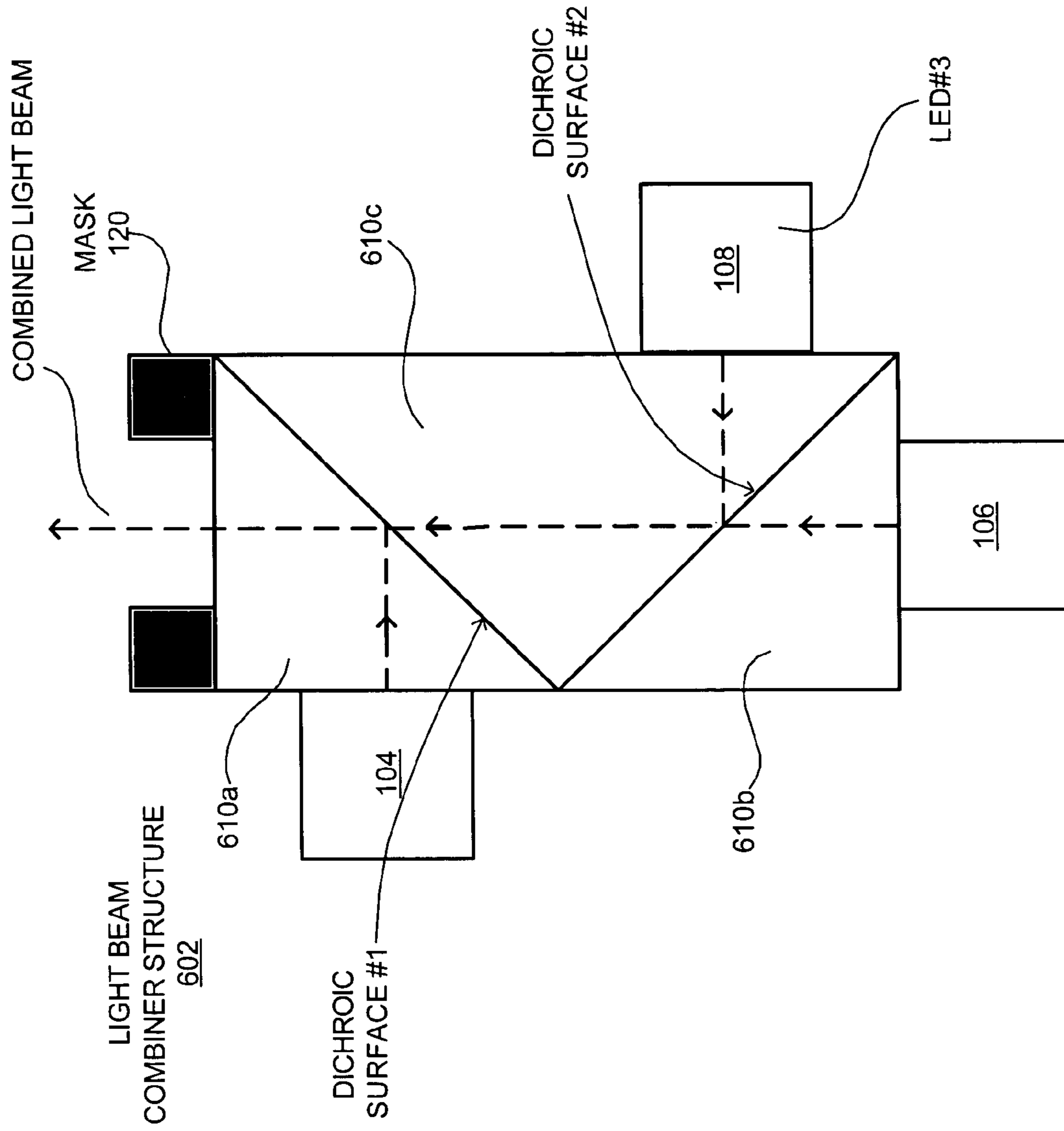

FIG. 6

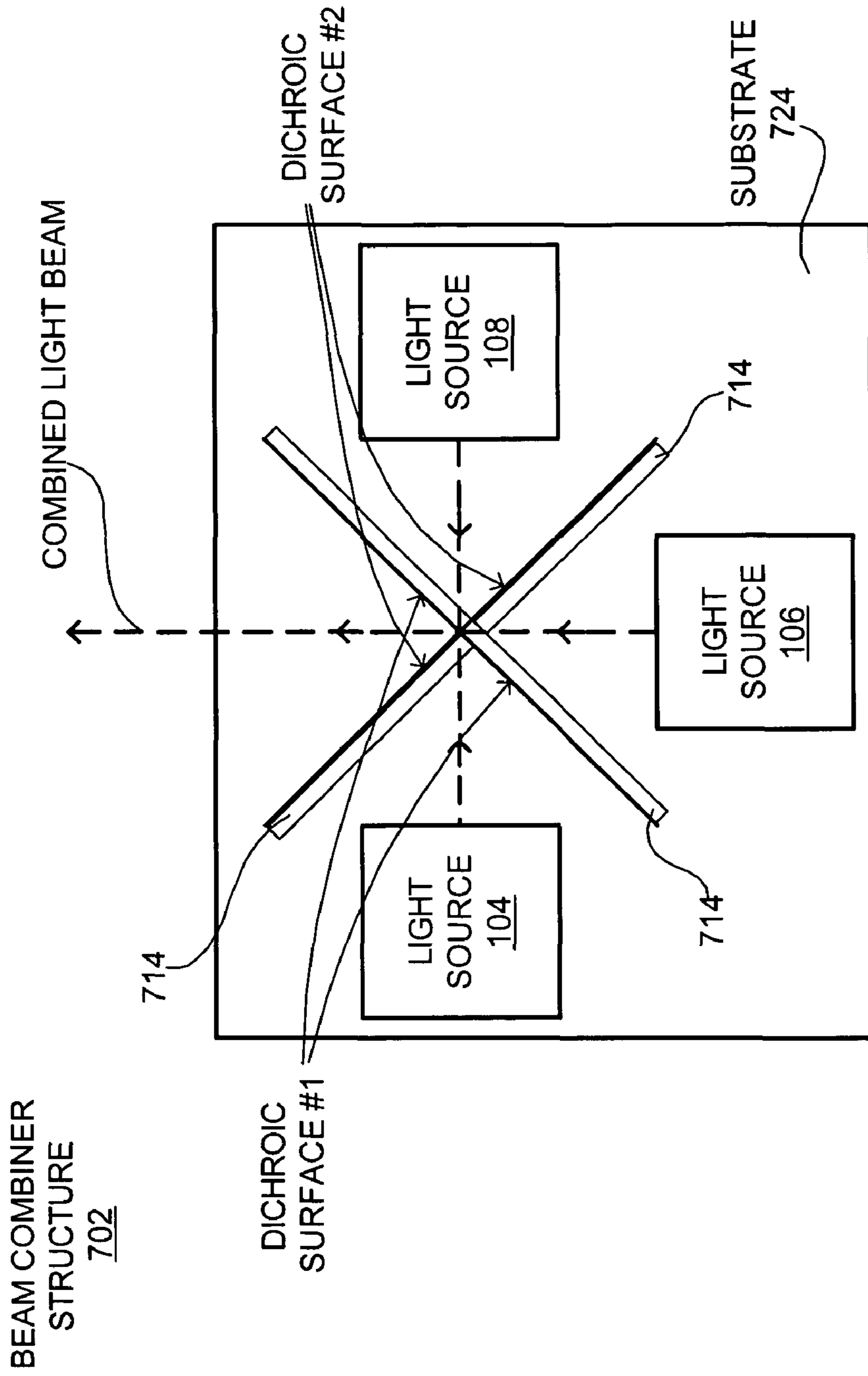

FIG. 7

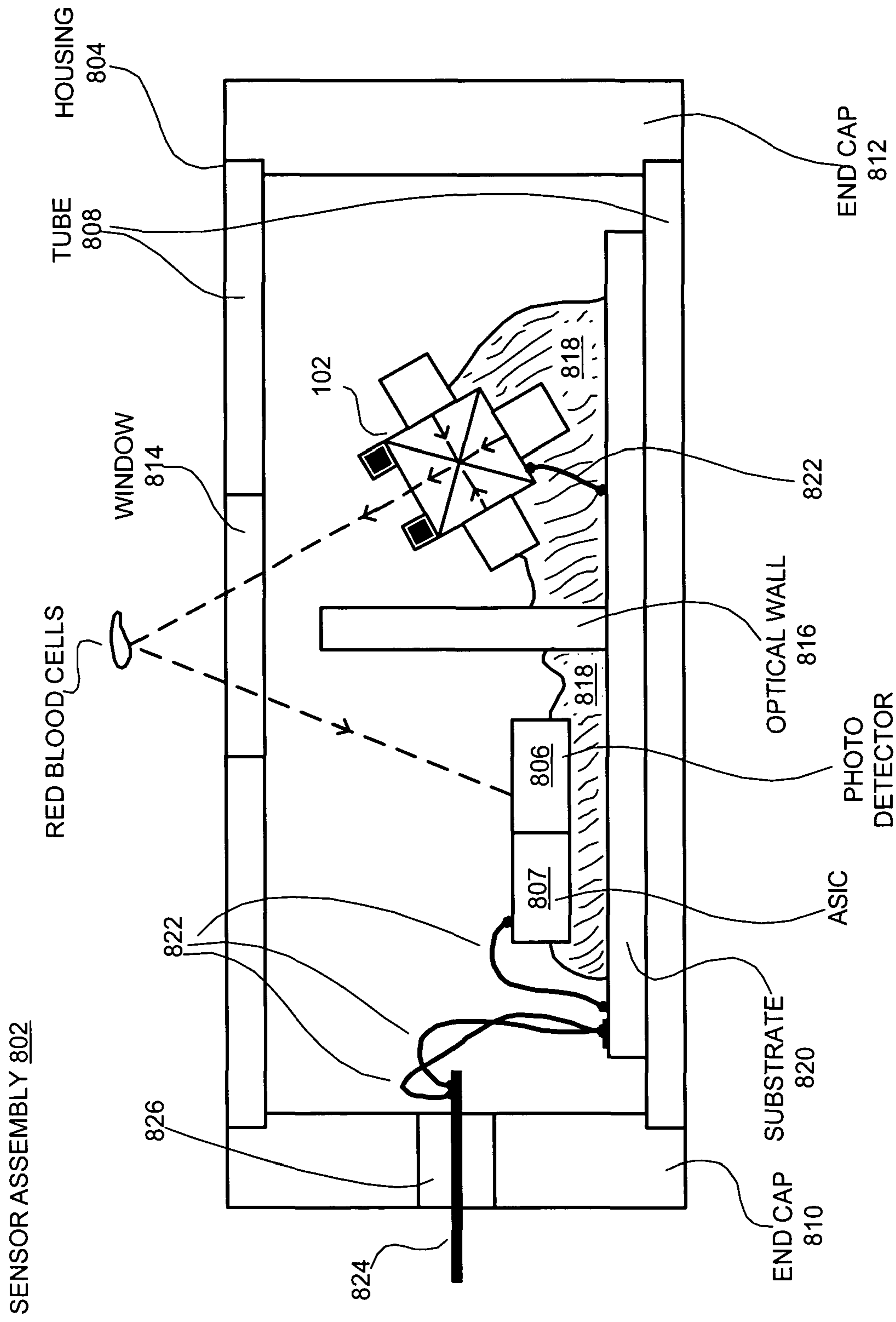

FIG. 8A

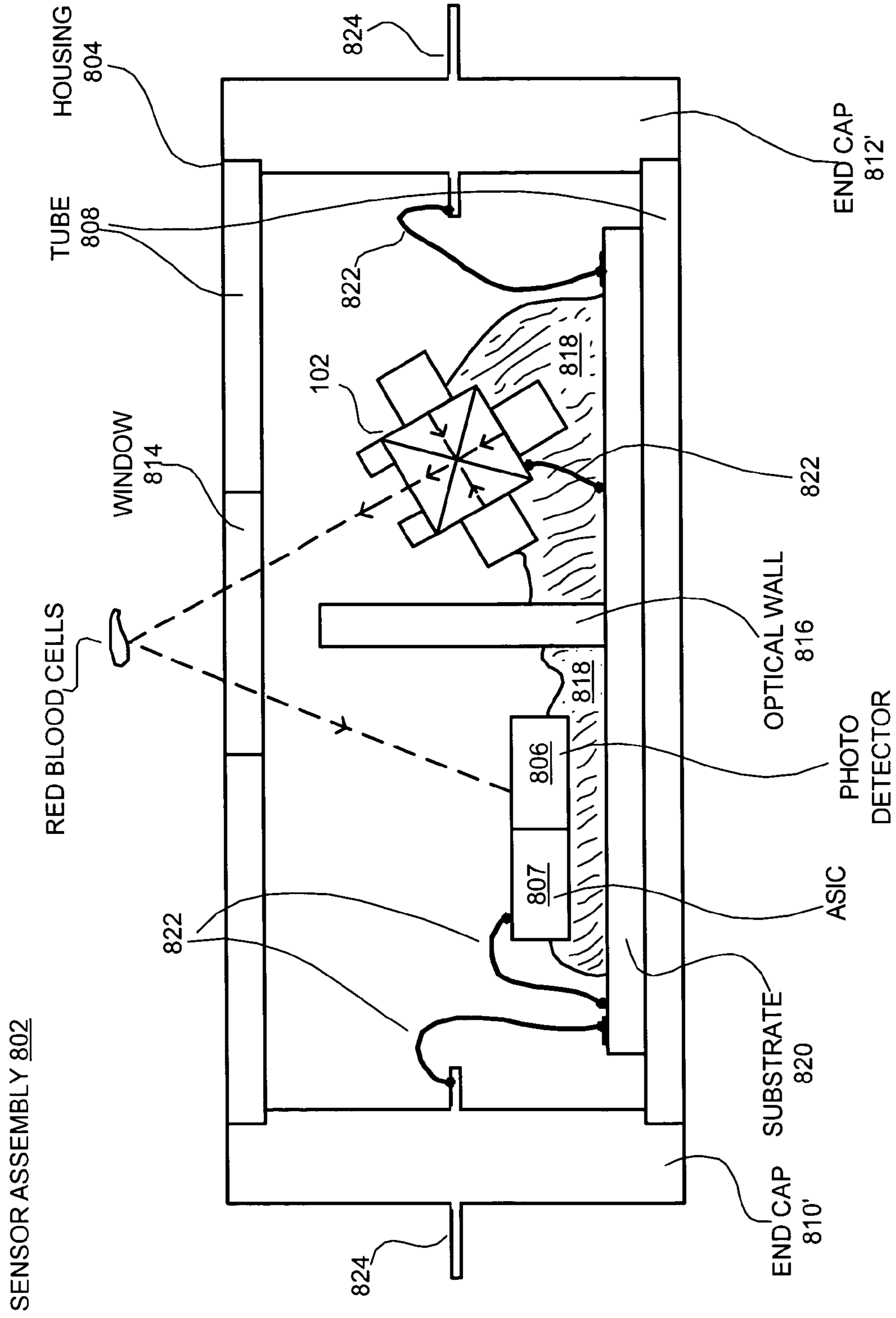

FIG. 8B

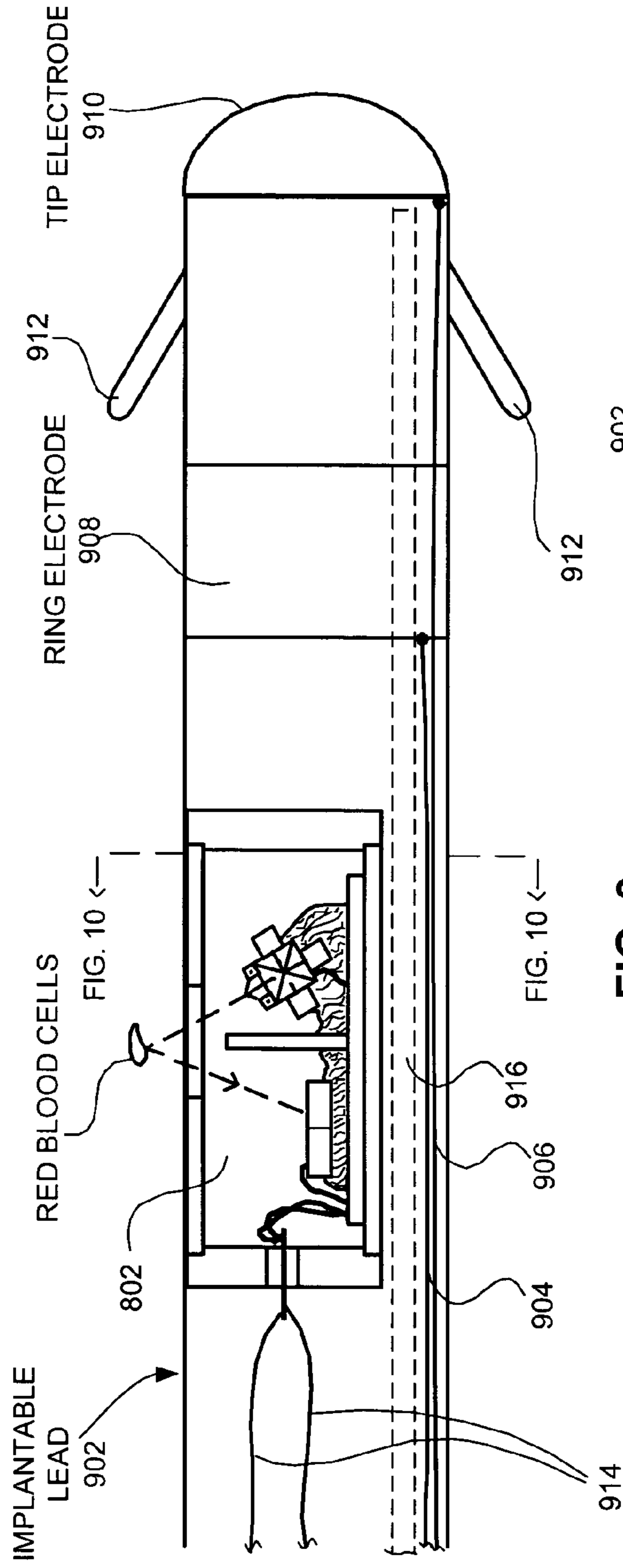

FIG. 9

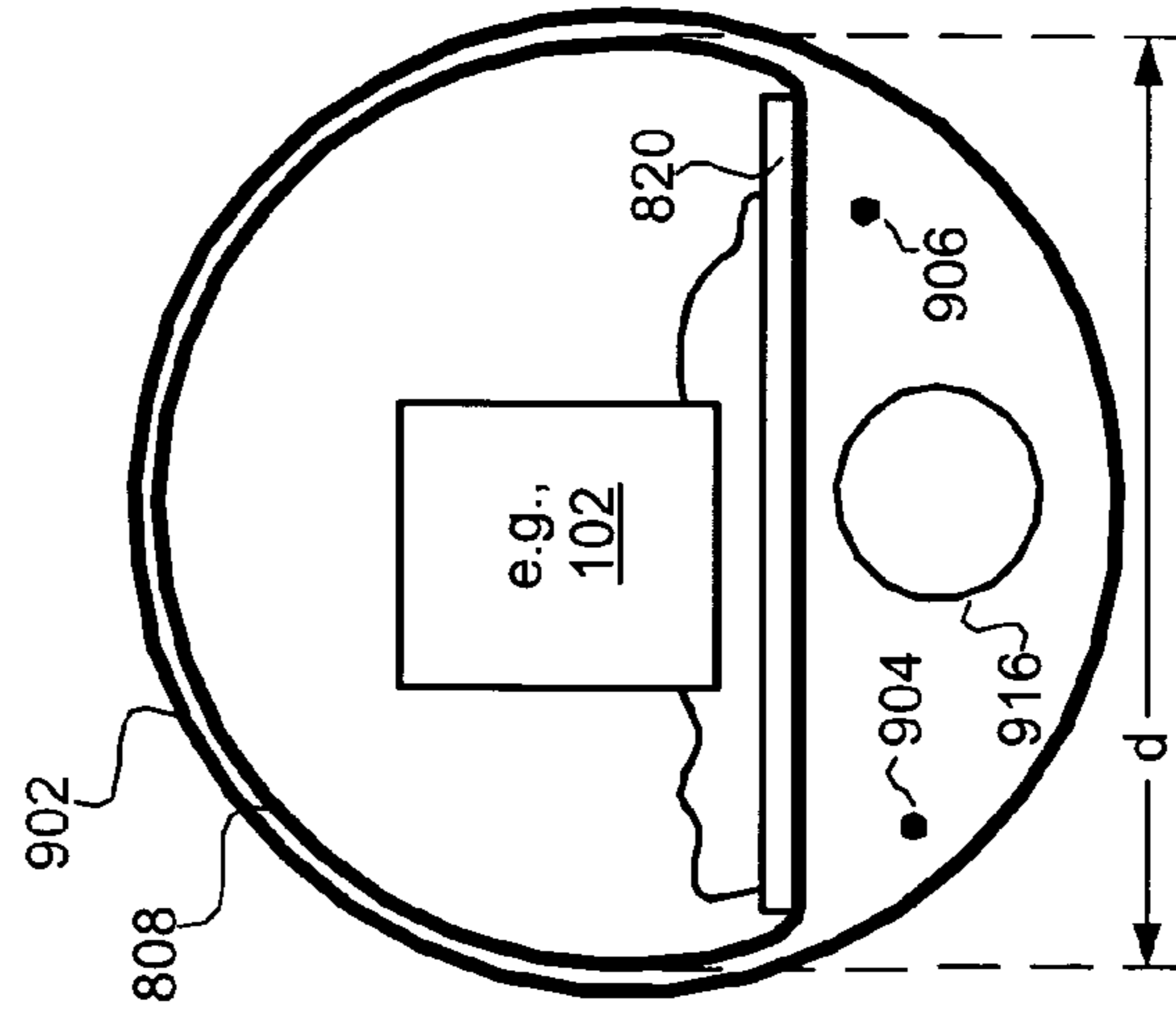

FIG. 10

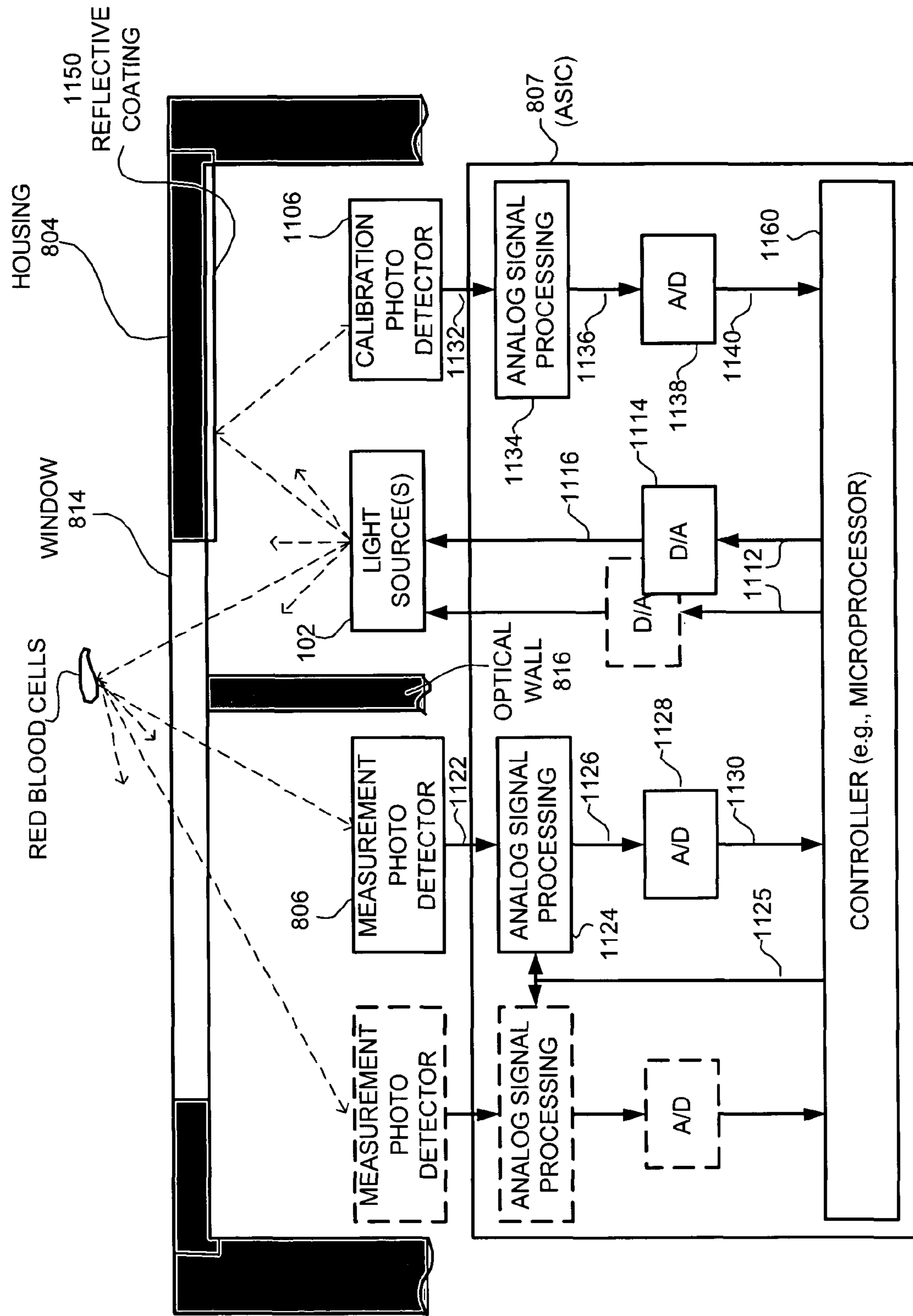

FIG. 11A

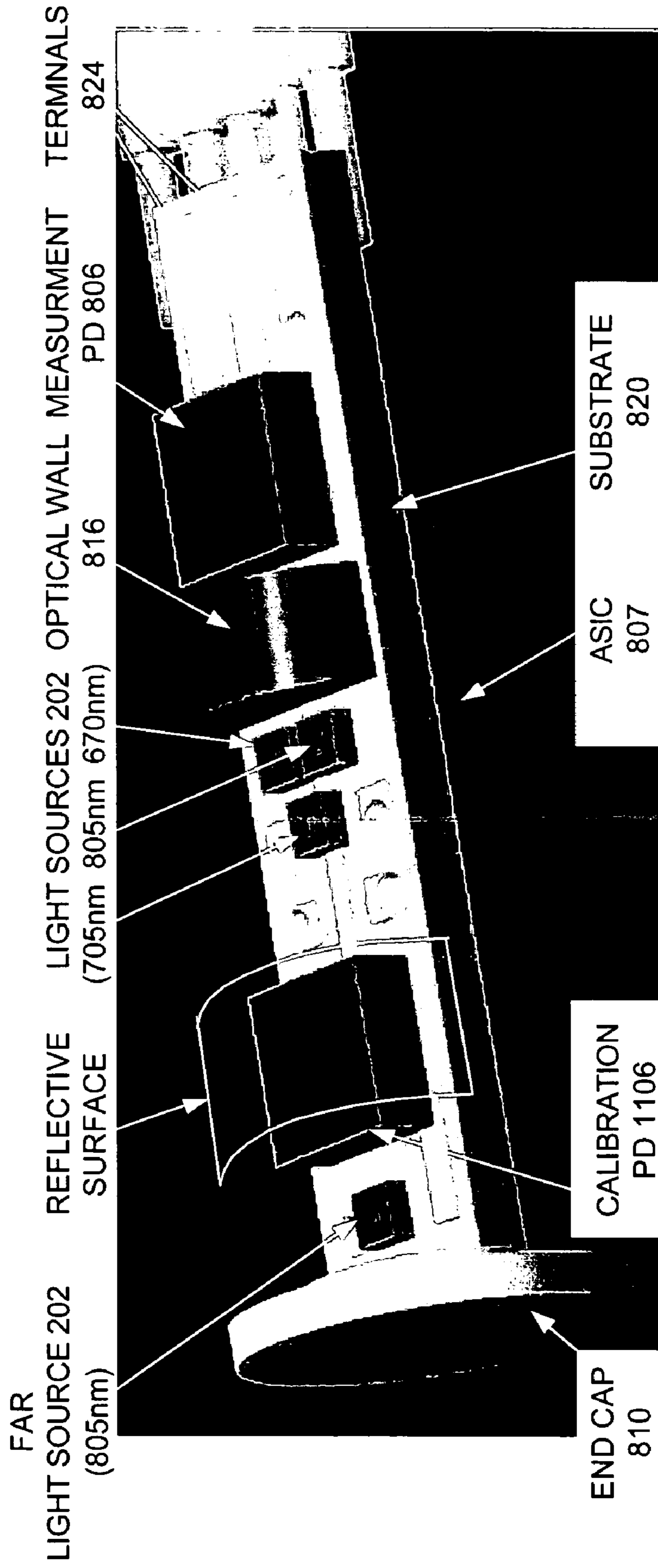

FIG. 11B

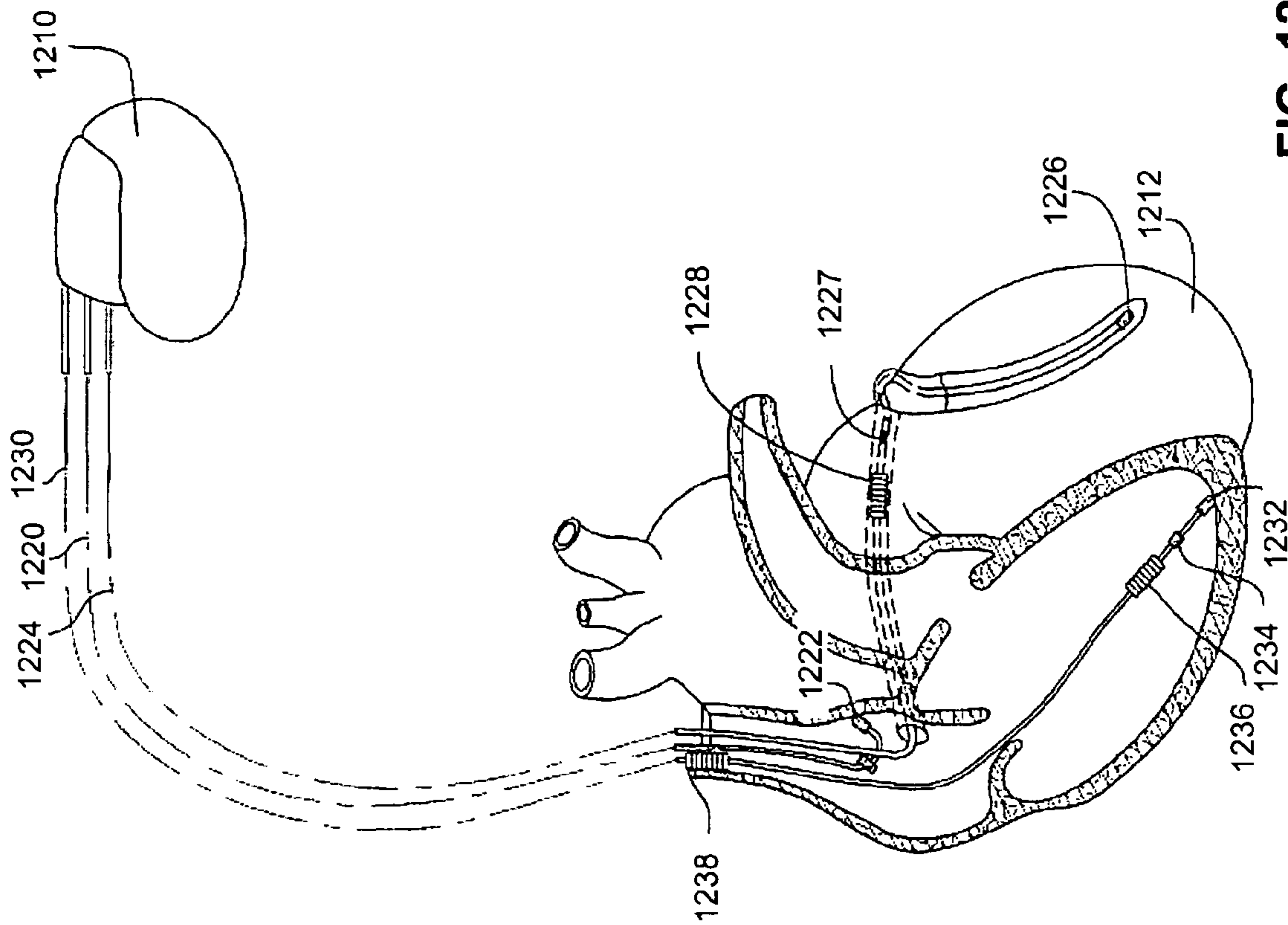

FIG. 12A

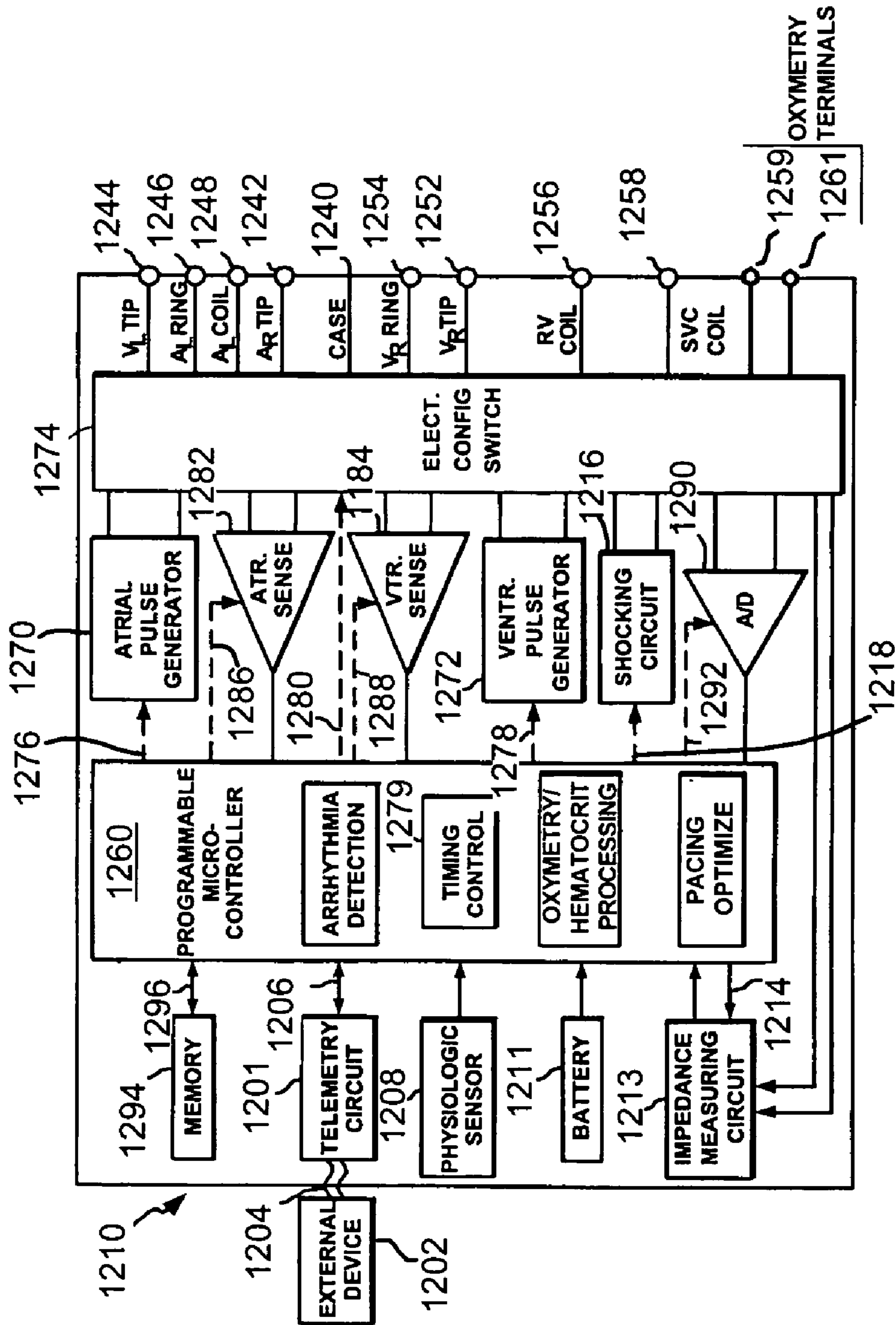

FIG. 12B

1

IMPLANTABLE SELF-CALIBRATING OPTICAL SENSORS

PRIORITY CLAIM

This application is a continuation-in-part of copending U.S. patent application Ser. No. 11/231,555, filed Sep. 20, 2005, entitled "Implantable Multi-Wavelength Oximeter Sensor".

FIELD OF THE INVENTION

Embodiments of the present invention relate to implantable self-calibrating optical sensors that are used, e.g., for obtaining measures of blood oxygen saturation and/or hematocrit.

BACKGROUND

Blood oxygen saturation is the relative amount of oxygenated hemoglobin in all of the hemoglobin present in the blood stream. This hemoglobin is packaged in biconcave discs of approximately 10 micrometers diameter which commonly occur with a density of approximately five million red blood cells per cubic millimeter. When radiant energy (e.g., light) is incident upon red blood cells, the red blood cells both scatter and transmit the incident radiant energy. The differential absorption by oxygenated and non-oxygenated hemoglobin of the radiant energy reflected by and transmitted through the red blood cells furnishes the basis for the oxygen saturation measurements.

More specifically, pulse oximeters use light of two or more different centered wavelengths (e.g., produced by two or more light sources) to obtain measures of blood oxygen saturation by measuring the absorption and/or scattering of oxyhemoglobin and reduced hemoglobin. The measured scattering data allows for the calculation of the relative concentrations of reduced hemoglobin and oxyhemoglobin, and therefore blood oxygen saturation levels, since the scattering relationships are known.

Most multi-wavelength pulse oximeters are non-implantable devices that are clipped onto a patient's finger or ear lobe. However, it is believed that it would be beneficial to chronically implant pulse oximeters so that measures of oxygen saturation and hematocrit (the density of red blood cells) can be used as feedback for pacing optimization, disease monitoring, and the like.

Some multi-wavelength implantable oximeter catheters are known, as can be appreciated from U.S. Pat. Nos. 3,847,483 and 4,114,604, each of which are incorporated herein by reference. For multi-wavelength oximeters to work properly, light from two or more light sources (e.g., from 670, 700 and 805 nm wavelength LEDs) should be combined into a single beam, to assure that the computed oxygen saturation is accurate with varying blood flow rate, pH, hematocrit and hemoglobin. In the devices of the '483 and '604 patents, fiber optic guides are used to combine the light of multiple wavelengths into the single beam. This, however, requires significant physical space. Thus, in the devices of the '482 and '604 patents, the light sources and fiber optic guides are located in a housing that is a distance from the measurement site, and optical fibers that are within a catheter are used to deliver the combined light beam to the measurement site at the distal end of the catheter.

It would be beneficial if an implantable optical combiner requiring less physical space can be provided, thereby enabling the optical combiner to be located at the measurement site.

2

The light sources that are used to produce the light useful for obtaining measures of blood oxygen saturation, etc., may produce light of less intensity, as such light sources age. If not compensated for, this will affect the intensity of the scattered light detected by a photo detector, which will in turn adversely effect determinations of blood oxygen saturation, etc. Accordingly, there is also a need to compensate for changes in the intensity of the light produced by such light sources.

SUMMARY

Embodiments of the present invention are directed to implantable systems, and methods for use therewith, that compensate for changes in the intensity of light transmitted by one or more light sources of the implantable systems. Such changes in intensity can be due, e.g., to aging of the light sources. The light sources can be, e.g., light emitting diodes (LEDs), but are not limited thereto.

In accordance with specific embodiments of the present invention, the implantable system includes an implantable housing including a window through which light can pass. The term window, as used herein, is intended to collectively encompass all portions of the housing through which light of interest can enter and exit the housing, even if such portions are separated from one another (e.g., by opaque portions). Included within the housing is at least one light source, a measurement light detector and a calibration light detector. Each light source transmits light of a corresponding wavelength. The intensity of the light transmitted by each light source is controlled by a corresponding drive signal that drives the light source. A portion of the light of each wavelength exits the housing through the window. The measurement light detector detects light of each wavelength scattered back into the housing through the window, and produces a measurement signal that is indicative of the intensity of the light of each wavelength detected by the measurement light detector. The calibration light detector detects a portion of the light of each wavelength that has not exited the housing, to produce a calibration signal that is indicative of the intensity of the light of the wavelength detected by the calibration light detector, which is indicative of the intensity of the light transmitted by each light source.

In accordance with specific embodiments, a controller adjusts each drive signal, based on the calibration signal, to keep the intensity of the light transmitted by each light source substantially constant. In accordance with other embodiments of the present invention, a controller adjusts the measurement signal, based on the calibration signal, to compensate for changes in the intensity of the light transmitted by each light source. In still other embodiments, rather than adjusting signals, a processor (that uses the measurement signal for a diagnostic and/or therapeutic purpose) detects changes in the intensity of the light transmitted by each light source based on the calibration signal, and takes into account the changes in intensity when using the measurement signal for a diagnostic and/or therapeutic purpose. For example, the processor can take such changes in intensity into account by making appropriate adjustments to algorithms that are used to determine levels of blood oxygen saturation and/or levels hematocrit based on the measurement signal.

This summary is not intended to be a complete description of the invention. Other features, aspects, objects and advan-

tages of the invention can be obtained from a review of the specification, the figures, and the claims.

BRIEF DESCRIPTION OF THE DRAWINGS

FIG. 1 illustrates an apparatus for combining light of three different wavelengths from three physically separate light sources, according to an embodiment of the present invention.

FIG. 2 illustrates an apparatus for combining light of two different wavelengths from two physically separate light sources, according to an embodiment of the present invention.

FIG. 3 illustrates an apparatus for combining light of two different wavelengths from two physically separate light sources, according to another embodiment of the present invention.

FIG. 4 illustrates an apparatus for combining light of three different wavelengths from three physically separate light sources, according to still another embodiment of the present invention.

FIG. 5 illustrates an apparatus similar to the one shown in FIG. 1, but with the addition of combiner lenses between the light sources and prisms.

FIG. 6 illustrates an apparatus for combining light of three different wavelengths from three physically separate light sources, according to a further embodiment of the present invention.

FIG. 7 illustrates how panels can be used in place of prisms.

FIG. 8A illustrates an implantable oximetry sensor, according to an embodiment of the present invention.

FIG. 8B illustrates an implantable oximetry sensor, according to another embodiment of the present invention.

FIG. 9 illustrates an implantable lead that includes the sensor of FIG. 8A, in accordance with an embodiment of the present invention.

FIG. 10 illustrates a rough cross-section of the lead shown in FIG. 9.

FIGS. 11A and 11B illustrate implantable self-calibrating sensors, according to embodiments of the present invention.

FIG. 12A illustrates an exemplary implantable stimulation device in electrical communication with a patient's heart by way of three leads, which are suitable for delivering multi-chamber stimulation and shock therapy.

FIG. 12B is a simplified block diagram of the multi-chamber implantable stimulation device of FIG. 12A.

DETAILED DESCRIPTION

The following description is of the best modes presently contemplated for practicing various embodiments of the present invention. This description is not to be taken in a limiting sense but is made merely for the purpose of describing the general principles of the invention. The scope of the invention should be ascertained with reference to the claims. In the description of the invention that follows, like numerals or reference designators will be used to refer to like parts or elements throughout. Also, the left-most digit(s) of a reference number identifies the drawing in which the reference number first appears.

FIG. 1 shows a first embodiment of the present invention that combines light of three different wavelengths from three physically separate miniature light sources using dichroic surfaces. Such dichroic surfaces are likely dichroic mirrors, but can be dichroic filters, or combinations thereof. Dichroic surfaces have the property of reflecting light of specific wavelengths and passing light of other wavelengths.

Referring to FIG. 1, a beam combiner structure 102, in accordance with an embodiment of the present invention, includes three physically separate light sources 104, 106 and 108, each of which produces radiation of a different wavelength (e.g., 670, 700 and 805 nm). The light sources are preferably light emitting diodes (LEDs), but can be other less preferable sources such as, but not limited to, laser diodes and incandescent lamps. The light sources are shown as being mounted to a structure (a cube in this example) which is made up of four triangular prisms 110a, 110b, 110c and 110d that are bonded together, e.g., using an optical cement or some other clear epoxy resin. Appropriate sides of the prisms are coated to thereby form a pair of dichroic surfaces, labeled dichroic surface #1 and dichroic surface #2. There are multiple ways this can be accomplished. However, it is believed that the most cost effective way is to have only one side of each prism 110a, 110b, 110c and 110d have a dichroic coating. For example, side 112a of prism 110a and side 112c of prism 110c can be coated to form dichroic surface #1, and side 112b of prism 110b and side 112d of prism 110d can be coated to form dichroic surface #2. While the prisms are likely made of glass, other suitable materials may be used, such as, but not limited to, plastics.

In accordance with an embodiment of the present invention, the dichroic surface #1 will reflect the wavelength (λ_1) generated by the light source 104, and pass the wavelengths (λ_2 and λ_3) generated by light sources 106 and 108. Similarly, the dichroic surface #2 will reflect the wavelength (λ_3) generated by the light source 108, and pass the wavelengths (λ_1 and λ_2) generated by light sources 104 and 106. This can be explained in more detail using an example where the wavelength generated by light source 104 is 670 nm, the wavelength generated by light source 106 is 700 nm, and the wavelength generated by light source 108 is 805 nm (e.g., λ_1 , λ_2 and λ_3 are, respectively, 670 nm, 700 nm and 805 nm). Continuing with this example, the present invention can be implemented if dichroic surface #1 reflects light below 685 nm and passes light above 685 nm, and dichroic surface #2 reflects light above 750 nm and passes light below 750 nm.

Still referring to FIG. 1, the dichroic surface #1 and the dichroic surface #2 and the light sources 104 and 108 are positioned (including angled) relative to one another such that light transmitted by the light source 104 is reflected by the dichroic surface #1 to travel in generally a same direction as light transmitted by the light source 108 that is reflected by the dichroic surface #2, as can be appreciated from the dashed lines shown. Additionally, the light source 106 is positioned such that its light, which passes through the dichroic surfaces #1 and #2, travels in generally the same direction as the just mentioned reflected light, as can also be appreciated from the dashed lines shown.

In practice, the light sources 104, 106 and 108 are serially energized, in a non-overlapping temporal relationship. In the manner just described, the light of wavelengths λ_1 , λ_2 and λ_3 are combined into a single combined beam 130 that is transmitted toward patient tissue that includes red blood cells. The light of different wavelengths (λ_1 , λ_2 , and λ_3) are combined into the single beam so that the light of each wavelength shines equally on nearby red blood cells, to thereby increase the likelihood that the computed oxygen saturation is accurate with varying blood flow rate, pH, hematocrit and hemoglobin. A mask 120 may be used to reduce internal reflections.

When transmitted toward patient tissue, some of the light energy is scattered by blood. The different wavelengths are differently scattered, depending on the oxygen saturation level of the blood. After being scattered by blood, the interleaved light stream is received by a light detector (discussed

5

below in more detail with reference to FIG. 8), which preferably produces a separate signal for each of the wavelengths. At a high level, time multiplexing is used to produce a signal path for each of the different wavelengths (λ_1 , λ_2 and λ_3) of received light. Each signal path will typically include one or more filters and an A/D converter to sample the received light signals. Using electronic circuitry, firmware and/or software, the received light signals can be analyzed so that oxygen saturation levels can be determined in any well known manner, or in any manner devised in the future.

While three-wavelength pulse oximetry provides more accuracy than two-wavelength pulse oximetry, the accuracy obtained using two-wavelength pulse oximetry is satisfactory for many applications. Accordingly, in accordance with embodiments of the present invention, one of the light sources **104**, **106** and **108** can be eliminated. If light source **106** is eliminated, then two dichroic surfaces are still needed, as can be appreciated from FIG. 3. However, if light source **104** (or light source **108**) is eliminated, then only a single dichroic surface is necessary, as shown in FIG. 2.

Referring to FIG. 2, the single dichroic surface reflects the wavelength generated by the light source **104** and passes the wavelength generated by the light source **106**. Since only one dichroic surface is used, the assembly of prisms can be simplified. More specifically, the structure (also a cube in this example) can be made up of only two triangular prisms **210a** and **210b**.

In FIGS. 1, 2 and 3, the overall structures, formed from multiple prisms, were shown as being cubic. While embodiments of the present invention encompass such cubic structures, they should not be limited thereto. For example, other shapes, such as the ones shown in FIGS. 4 and 6, can be used. As can be seen from FIG. 4, the prisms **410a**, **410b**, **410c** and **410d** that make up the structure form a shape that resembles a trapezoid. Also shown in FIG. 4 is that not all outer sides of the structure need be flat. More specifically, in this example, the outer side **414** of prism **410d**, through which the combined light beam travels, is shown as being concave, to increase the exit angle. Also shown in FIG. 4 is that not all of the prisms need be of the same size and shape.

Referring now to FIG. 5, in accordance with an embodiment of the present invention, combiner lenses **522** can be added for reducing the emitted light angle before the light is combined by the dichroic surfaces. Such lenses **522** can be added in any of the embodiments described herein.

FIG. 6 illustrates a variant of the present invention that has a simpler but likely somewhat larger overall size than the structure shown in FIG. 1. In this embodiment, only three prisms **610a**, **610b** and **610c** are used to form a three-dimensional rectangular structure. Another difference is that the pair of dichroic surfaces do not intersect each other, as was the case in the previously discussed embodiments where there were three light sources. The beam combining structure **602** functions in a similar manner as the other structures discussed above. That is, dichroic surface #1 reflects the wavelength of light generated by the light source **104**, and passes the wavelengths of light generated by the light sources **106** and **108**. The dichroic surface #2 reflects the wavelength of light generated by the light source **108** and passes the wavelength of light generated by the light source **106**. Because the light generated by the light source **104** is not incident upon the dichroic surface #2, it is not required that the dichroic surface #2 pass the wavelength generated by the light source **104**, but it is allowed.

In the above discussed FIGS. 1 through 6, the dichroic surfaces were described as being formed on sides of prisms. The use of such structures is beneficial because the prisms can

6

be bonded together to form a sturdy structure to which the light sources can be securely attached, as shown in the FIGS. However, in alternative embodiments, explained below with reference 7, this need not be the case.

Referring to FIG. 7, rather than using prisms, panels **714** are attached on at least one edge to a substrate **724**, and dichroic surface(s) are formed on sides of the panels **714**. While the panels **714** are likely made of glass, other suitable materials such as plastics may be used. (For FIG. 7, picture the substrate **724** being in the same plane as the page, and panels **714** extending perpendicularly out of the page.) In this embodiment, rather than securing the light sources **104**, **106** and **108** to prisms, as could be done in the previously discussed embodiments, the light sources **104**, **106** and **108** are secured to the same substrate **724** to which the panels **714** are secured. As was discussed above with reference to FIGS. 2 and 3, one of the light sources can be eliminated if two-wavelength pulse oximetry is to be used. Further, as was explained with reference to FIG. 2, if the light source to be eliminated is light source **104** or **108**, then only one dichroic surface is required, which can be implemented using a single panel **714**. In a similar manner as was described above with reference to FIGS. 4 and 6, the light sources and dichroic surfaces can be repositioned, so long as the arrangement results in the light of various wavelengths generally being combined into a single beam. Further, as was described with reference to FIG. 5, combiner lenses **522** can be added to the configuration shown in FIG. 7.

While the above described embodiments included either two or three separate light sources, one of ordinary skill in the art would understand, based on the above description, that light from more than three light sources can be combined in a similar manner. Accordingly, it is within the spirit and scope of the present invention that more than three light sources and more than two dichroic surfaces can be used. Such embodiments can be used for multi-wavelength oximetry that uses more than three wavelengths.

In accordance with other embodiments of the present invention, critical angle reflectors could be used instead of dichroic surfaces to accomplish combining of light from the two or more separate light sources. The critical angle is the largest angle off a surface at which light will be totally reflected from the surface. Sides of prisms or panels can be positioned relative to light sources such that light of two or more wavelengths, from two or more separate light sources, can be combined into a single beam in much the same way as was described above with the use of dichroic surfaces.

In accordance with embodiments of the present invention, the beam combiner assemblies discussed above can be built into a sensor assembly **802**, such as those shown in FIGS. 8A and 8B. The sensor **802**, in turn, can be built into an implantable lead **902**, such as that shown in FIG. 9.

Referring to FIG. 8A, in accordance with an embodiment of the present invention the sensor assembly **802** includes a sensor enclosure or housing **804** within which are one of the beam combiner structures discussed above, a photo detector **806** and an optional application specific integrated circuit (ASIC) **807**. In FIG. 8A, the beam combiner **102** is shown. However, any of the other beam combiners **202**, **302**, **402**, **502**, **602** and **702** may alternatively be used. In accordance with an embodiment of the present invention, the housing **804** includes a tube **808** and a pair of end caps **810** and **812** that can be used to hermetically seal the components within the housing **802**. The tube **808** can be made of an opaque material, such as metal (e.g., titanium or stainless steel) or ceramic, so long as it includes a window **814** that passes light of all the wavelengths of interest in the combined light beam (e.g.,

130). In an alternative embodiment, the entire tube **808** can be made of a material that passes light of all the wavelengths of interest in the combined beam, and thus, in this embodiment the entire tube can be considered a window. The window **814** can for example be made of synthetic sapphire or some other appropriate material that passes light of all the wavelengths of interest. Alternatively, the entire tube **808** can be made from synthetic sapphire or some other appropriate material that passes light of all the wavelengths of interest. Exemplary synthetic sapphires are marketed by Imeta, Inc. (Elmsford, N.Y.) and Swiss Jewel (Philadelphia, Pa.).

The beam combiner structure (e.g., **102**), the window **814** and the photo detector **806** should be positioned such that the combined light beam produced by the beam combiner exits the housing **804** through the window **814** and such that the light backscattered from blood (outside the window) will be scattered back toward the photo detector **806**. The optional ASIC **807**, which can include filters, analog-to-digital circuitry, multiplexing circuitry, and the like, controls the light sources and processes the photo detector signals produced by the photo detector **806** in any manner well known in the art. The ASIC **807** preferably provides digital signals indicative of the photo detector signals to an implantable device, such as an implantable monitor, pacemaker, or ICD. If the ASIC **807** or equivalent circuitry is not included within the sensor, analog signals can be delivered between the sensor **802** and the implantable device. However, it is preferred that digital signals are sent to and from the sensor **802** because digital signals are less susceptible to noise and other degradation.

An opaque optical wall **816** is positioned between the beam combiner structure **102** and the photo detector **806**, so that light is not internally reflected from the beam combiner **102** to the photo detector **806**. The beam combiner **102**, optical wall **816**, photo detector **806** and ASIC **807** can be attached to a substrate **820**, e.g., by an epoxy **818**. The substrate can be, e.g., a printed circuit board (PCB). Bond wires **822** can be used to attach the various components to the substrate **820**, as well as to attach the substrate **820** to terminals **824** which extend through an insulated feedthrough **826** in the end cap **810**. The housing **804**, the feedthrough **826** and the endcaps **810** and **812** preferably provide hermeticity. In an alternative embodiment, shown in FIG. **8B**, the endcaps **810'** and **812'** are made of a conductive material, and the tube **808** is made of a nonconductive material (so that the endcaps are electrically isolated from one another). In such an embodiment, there is no need for the feedthrough **826** shown in FIG. **8A** because the terminals **824** can be connected directly to the conductive endcaps **810'** and **812'**. Nevertheless, a feedthrough may be used in the embodiment of FIG. **8B** if desired.

Referring now to FIG. **9**, in accordance with specific embodiments of the present invention, the sensor module **802** is built into an implantable lead **902**. Accordingly, in this embodiment, the housing **804** of the sensor module **802** is sized to fit within the implantable lead **902**. More specifically, the size of the beam combiner is preferably about 2 millimeters (mm) or less, and the size (shown as "d" in FIG. **10**) of the sensor module **802** is about 4 mm or less, and preferably about 3 mm. The length of the sensor module **802**, which extends axially in the lead **902** can be somewhat larger, because the length of the lead **902** is relatively large as compared to the diameter of the lead.

Further, the portion of the lead **902** that is adjacent to the window of the **814** of the sensor module, where light is to exit and enter, should allow the light to pass in and out of the sensor **802**. Thus, the lead **902** may be transparent, or include its own window, opening, or the like. The lead **902** is shown as including tines **912** for attaching the lead in its desired posi-

tion, but may include any other type of fixation means, or none at all. Additionally, the lead **902** may also include a lumen **916** for a stylet, which can be used for guiding the lead to its desired position. Also shown in FIG. **9** are wires **914** that provide power and possibly control signals to the sensor **802** from an implantable device, and provide pulse oxymetry signals from the sensor **802** to the implantable device. As discussed below, preferably there are only two wires **914**, but there may be more. If the sensor **802** of FIG. **8B** is used, then one wire **914** is attached to the terminal **824** that extends from the endcap **810'**, while another wire **914** is attached to the terminal **824** that extends from the other endcap **812'**.

The lead **902** can be, e.g., an implantable right atrial lead for implant in a patient's right atrial appendage, a right ventricular lead for transvenous insertion into the heart, a coronary sinus lead for placement in the coronary sinus region, or some other lead. The lead **902** can be implanted in or near a patient's heart, but this is not necessary. The exemplary lead **902** shown in FIG. **9** is a right ventricular lead that includes a ring electrode **908** and a tip electrode **910** that are connected to an implantable device by way of wires **904** and **906**. Instead of being placed in a lead that includes cardiac electrodes, the sensor can be within a catheter intended for placement in a blood vessel or other blood confining space.

Referring now to FIG. **10**, which is a rough cross-sectional view along the dashed line shown in FIG. **9**, in accordance with an embodiment of the present invention the tube portion **808** of the sensor housing **804** is generally "D" shaped, so that it can be readily included with the implantable lead **902**, while still allowing the lumen **916** (for a stylet) and wires **904** and **906** to fit within the same inner-space of the lead **902**. Alternative shapes are also within the scope of the present invention. If the sensor **802** of FIG. **8B** is used, then one of the wires **914** would also be seen in the cross-section of FIG. **10**.

After the ASIC **807** controls the light sources the processes signals produced by the photo detector **806** in a manner well known in the art, it delivers signals indicative of the intensity of the detected light to an implantable device, an example of which is discussed below with reference to FIGS. **12A** and **12B**. The implantable device further processes the signal, e.g., for diagnostic and/or therapeutic use. Preferably, the ASIC **807** has all electronics to provide a two-wire **914** digital interface to the implantable device, as shown in FIG. **9**. Further, one of the two sensor wires **914** may be combined with one of the pacing electrode wires **904** or **906** so that only three total wires are needed. Even further, a more complex 2-wire approach could use sub-pacing threshold signals between the implantable device and the sensor **802** using the same two wires **904** and **906** that connect to the pacing electrodes **908** and **910** resulting in a total of two wires in the lead **902** to the implantable device.

The lead **902** within which the sensor **802** is contained is attached to an implantable device. It is also possible that the sensor **802** is within a self contained hermetically sealed housing that communicates wirelessly with the implantable device. As mentioned above, the implantable device can be, e.g., a monitor, pacemaker, or ICD. For completeness, an exemplary implantable device **1210**, that can be used to perform pacing, detect an arrhythmia, perform anti-arrhythmia therapy, detect specific cardiac events, etc., is described with reference to FIGS. **12A** and **12B**.

In accordance with embodiments of the present invention, the components are hermetically sealed within the sensor **802**. Preferably the only elements running to and from the sensor **802** are wires **914** for providing power and possibly control signals to the sensor **802**, and receiving pulse oxymetry signals from the sensor **802**.

In accordance with other embodiments of the present invention, the oxymetry sensor module **802** is located within the housing of an implantable device that includes a window through which light can be transmitted and received. In still another embodiment, the oxymetry sensor module **802** is in its own hermetically sealed housing that is attached directly to an implantable cardiac device. Additional details of how this can be accomplished are provided in commonly assigned U.S. patent application Ser. No. 10/913,942, entitled "Autonomous Sensor Modules for Patient Monitoring" (Turcott et al.), filed Aug. 5, 2004, which is incorporated herein by reference.

As mentioned above, the ASIC **807** (and/or other circuitry) controls the light sources and processes signals produced by the photo detector **806**, as well as delivers signals indicative of the intensity of the detected light to an implantable device, an example of which is discussed below with reference to FIGS. **12A** and **12B**. The implantable device further processes the signal, e.g., for diagnostic and/or therapeutic use. For example, the implantable device can include a microcontroller that determines levels of blood oxygen saturation and/or hematocrit based on the signals it receives from the photo detector **806**. Such measures of oxygen saturation can be used, e.g., for pacing optimization, disease monitoring, and the like. Additionally or alternatively, the measures of oxygen saturation can be stored in memory for later transmission to an external device.

As also mentioned above, the ASIC **807** (and/or other circuitry) can include filters, analog-to-digital circuitry, multiplexing circuitry, and the like, to control the light sources and process the photo detector signals produced by the photo detector **806**. The ASIC **807** preferably provides digital signals indicative of the photo detector signals to an implantable device, such as an implantable monitor, pacemaker, or ICD. If the ASIC **807** or equivalent circuitry is not included within the sensor, analog signals can be delivered between the sensor **802** and the implantable device. However, it is preferred that digital signals are sent to and from the sensor **802** because digital signals are less susceptible to noise and other degradation. It is also possible, as mentioned above, that the sensor module **802** is located within the housing of an implantable device that includes a window through which light can be transmitted and received, or that the sensor module **802** is in its own hermetically sealed housing that is attached directly to an implantable cardiac device.

Each light source (e.g., LED) transmits light in response to being driven by a drive signal, which is typically a current signal, but can be a voltage signal. As the light sources age they become less efficient in that for a same drive signal they will transmit light of less intensity. If not compensated for, this will affect the intensity of the light detected by the photo detector **806**, which will in turn adversely effect determinations of blood oxygen saturation, etc. In accordance with specific embodiments of the present invention, to overcome this problem, a calibration photo detector **1106** is added, the output of which is used to compensate for aging or other changes to the light source(s), as will now be described with reference to FIG. **11A**.

FIG. **11A** shows additional details of the ASIC **807**, in accordance with specific embodiments of the present invention. However, it should be noted that the circuitry shown in FIG. **11A** need not be implemented within the ASIC **807**. For clarity, the photo detector **806** that detects light scattered back into the housing **804** through the window **814** will often be referred to hereafter as the measurement photo detector **806**, and the added photo detector **1106** that is used to compensate for changes in the light sources (e.g., due to aging) will be

referred to as the calibration photo detector **1106**. Additionally, when discussing FIG. **11A**, the beam combiner structure **102** will often be referred to simply as light source(s) **102**, because the embodiments that relate to compensation can be used with a single light source, or with a device that does not necessarily use the specific beam combiners described above. Nevertheless, the embodiments described with reference to FIG. **11A** would be very useful with the beam combiners described above.

Referring to FIG. **11A**, each light source transmits light having an intensity that is controlled by a corresponding drive signal **1112/1116**. Such drive signal is controlled by a controller **1160**, which likely outputs a digital drive control signal **1112** which is converted to an analog drive signal **1116** by a digital-to-analog converter (D/A) **1114**. The controller **1160** in this embodiment, and other embodiments, can be a microcontroller, a processor, a state machine, random logic, or the like. The light output by the light source(s) is projected over a wide range of angles (e.g., from 120 degrees to 180 degrees). Accordingly, a portion of this light exits the housing **804** through the window **814**, while other portions of the light are internally reflected.

As explained above, the opaque optical wall **816** is positioned between the light source(s) **102** and the measurement photo detector **806**, to prevent the measurement photo detector **806** from detecting internally reflected light. (It is noted, that due to imperfections, the measurement photo detector **806** may detect a small amount of internally reflected light, which is allowed). In contrast, the calibration photo detector **1106** is placed on the same side of the wall **816** as the light sources **102**, and positioned relative to the window **814** such that the calibration photo detector **1106** detects internally reflected light from the light source(s) **102** without detecting light that is scattered back into the housing **804** through the window **814**. (It is noted, that due to imperfections, the calibration photo detector **806** may detect a small amount of scattered light, which is allowed). Alternatively, the region of the window above the calibration photo detector **1106** can have a blocking or a reflecting coating **1150** such that the calibration photo detector **1106** generally only detects internally reflected light from the light source(s) **102**. It is also possible that the calibration photo detector **1106** is arranged such that it detects light transmitted directly from the light source(s) **102**, i.e., the light need not be internally reflected. For simplicity, the window **814** in FIG. **11A** and the previously described FIGS. has been generally shown as a single portion through which light of interest can enter and exit the housing **804**. However, it is noted that such window **814** can be made up of more than one distinct portion through which light of interest can enter and exit the housing **804**. For example, light may exit the housing **804** through a first portion of the window **814**, while scattered light enters the housing **804** through a second portion of the window **814**, where the first and second portions of the window are not contiguous. In other words, the term window **814**, as used herein, is intended to collectively encompass all portions of the housing through which light can enter and exit the housing, even if such portions are separated from one another (e.g., by opaque portions).

In the above arrangement of FIG. **11A**, the measurement photo detector **1106** detects light scattered back into the housing **804** through the window **814**, and produces a measurement signal **1122** that is indicative of the intensity of the light detected by the measurement light detector **1106**. The measurement signal **1112** is preferably filtered and amplified by an analog signal processing block **1124** (e.g., which includes a filter and amplifier), and digitized by an analog-to-digital

11

(A/D) converter **1128**, so that a digitized version **1130** of the signal is provided to the controller **1160**.

The calibration light detector **1106**, on the other hand, detects a portion of the light transmitted by the light source(s) that has not exited the housing **804** (e.g., the light is internally reflected and/or received directly from the light source(s)), and produces a calibration signal **1132** that is indicative of the intensity of such detected light. The calibration signal **1132** is preferably filtered and amplified by an analog signal processing block **1134** (e.g., which includes a filter and/or amplifier) and digitized by an analog-to-digital (A/D) converter **1140**, so that a digitized version **1140** of the signal is provided to the controller **1160**.

In FIG. **11A**, a separate D/A converter **1114** and drive signal **1112** are shown for each light source. In an alternative embodiment, the controller can output a time multiplexed drive signal **1112** that is provided to a single D/A converter **1114**, and a demultiplexer can be provided at the output of the D/A converter **1114**. Such a demultiplexer will provide the analog version of the drive signal to the appropriate light source. Similarly, in FIG. **11A** the measurement photo detector **806** is shown as having its own analog signal processing block **1124** and A/D converter **1128**, and the calibration photo detector **1106** has its own analog signal processing block **1134** and A/D converter **1138**. In an alternative embodiment, a multiplexer is provided at the outputs of the detectors **806** and **1106** so that a single analog signal processing block and A/D converter can be used. In other words, such a multiplexer can be provided between a single analog signal processing block and the detectors **806** and **1106**. Such embodiments would reduce the circuitry, e.g., of the ASIC **807**.

The calibration signal **1132**, or the filtered, amplified and digitized version thereof (i.e., **1140**), is used to compensate for changes to the lights source(s) **102**, e.g., due to aging, as will be described below. For example, in specific embodiments, the controller **1160**, adjusts the drive signal **1112**, based on the intensity of the light detected by the calibration photo detector **1106**, in order to keep the intensity of light transmitted by a light source substantially constant. More specifically, the controller **1160** adjusts the drive signal **1112**, based on the calibration output signal **1132**, or the filtered, amplified and digitized version thereof (i.e., **1140**), to keep the intensity of the light transmitted by each light source substantially constant. Where there are two or more light sources, this does not necessarily mean that all the light sources will be kept at a same substantially constant intensity. Rather, this means that the intensity of each individual light source is kept substantially constant, but that the intensity of one light source can be different than the intensity of another light source. In a specific embodiment, the intensity of light transmitted by a light source is kept substantially constant by adjusting the drive signal **1112** in an effort to keep the portion of the calibration signal **1132** corresponding to that light source at a specified level.

In alternative embodiments, rather than adjusting the drive signals **1112** to compensate for changes to the lights source(s) **102**, adjustments are made to the measurement signal **1122** to compensate for changes in the intensity of the light source(s) **102**. This can be accomplished as follows. The controller **1160** detects changes (likely reductions) in the intensity of the light source(s) **102** by detecting changes in the calibration signal **1132**, or the filtered, amplified and digitized version thereof (i.e., **1140**), in a similar manner as was discussed above. Then, based on the changes in the calibration output signal **1132**, or the filtered, amplified and digitized version thereof (i.e., **1140**), the controller **1160** adjusts the measurement signal **1122**. This can be accomplished, e.g., by using a

12

gain adjustment signal **1125** to adjust the gain of an amplifier within the analog signal processing block **1124**. For example, if the controller detects a 5% reduction in the intensity of light of a specific wavelength (i.e., light from a specific light source) based on the calibration signal **1132**, the controller can increase the gain in an amplifier of the analog signal processing block **1124** by 5%.

In still other embodiments, rather than adjusting actual signals (e.g., a drive signal or measurement signal), a processor algorithmically compensates for changes to the intensity of the lights source(s) **102**. More generally, a processor that uses the measurement signal **1122** (for a diagnostic and/or therapeutic purpose), detects changes in the intensity of the light transmitted by each light source based on the calibration signal, and the processor takes into account such changes in intensity when using the measurement signal for its diagnostic and/or therapeutic purpose. For example, if the controller detects a 5% reduction in the intensity of light of a specific wavelength (i.e., light from a specific light source) based on the calibration signal **1132**, the processor can take such reduction into account when determining levels of blood oxygen saturation and/or levels of hematocrit. For example, if the processor uses a multi-dimensional lookup table to determine levels of blood oxygen saturation, based on the intensity of detected scattered light, the processor can adjust where to look in the look-up table based on changes in the calibration signal. For another example, if the processor uses an algorithm to determine levels of blood oxygen saturation, based on the intensity of detected scattered light, the processor can make adjustments to the algorithm based on changes in the calibration signal. These are just a few examples of how a processor can take into account changes in the intensity of the calibration signal when using the measurement signal for a diagnostic and/or therapeutic purpose. In specific embodiments, the processor that uses the measurement signal for its diagnostic and/or therapeutic purpose is in a separate implantable housing that is connected to the housing **804** by one or more lead. For example, the processor can be within a housing of a stimulation device (e.g., device **1210** of FIG. **12A**).

As mentioned above, in addition to using the above described sensors to measure levels of blood oxygen saturation, such sensors can also be used to measure levels of hematocrit, which refers to the percentage of packed red blood cells in a volume of whole blood. Various techniques are known for determining hematocrit based on scattered light. For example, light of about 500 nm and light of about 800 nm can be directed at a blood sample, and an algorithm can be used to calculate hematocrit based on the intensities of detected scattered light. In another technique, a pair of spatially separated photo detectors can be used to detect reflected infra red (IR) light, e.g., of 805 nm. The intensity of the IR light detected by the photo detector that is nearer to the IR light source is referred to as IRnear, and the intensity of the IR light detected by the photo detector farther from the IR light source is referred to as IRfar. As described in article by Bornzin et al., entitled "Measuring Oxygen Saturation and Hematocrit Using a Fiberoptic Catheter", *IEEE/9th Annual Conf of the Eng. & Biol. Soc.* (1987), which is incorporated herein by reference, the ratio: $R = IR_{near}/IR_{far}$ is directly related to the level of hematocrit, but independent of oxygen saturation because 805 nm is an isobestic wavelength. To implement this technique using the sensor configuration shown in FIG. **11A**, a second measurement photo detector **806** (shown in dashed line) can be added, with the second measurement photo detector being further from (or closer to) the light source(s) **102** than the other measurement photo

detector **806**. This second measurement photo detector can have its own corresponding analog signal processing block and A/D converter, or such circuitry can be shared (e.g., multiplexed) with the other measurement photo detector. The above described embodiments of the present invention can be used to compensate for changes in the intensity of the IR light source, e.g., due to aging. In specific embodiments of the present invention, the second measurement photo detector is placed within the housing **804** as shown in FIGS. **8A**, **8B**, **9** and **10**, thereby enabling levels of hematocrit to be measured without the need for relatively large fiber optic guides, use of which was taught in the above mentioned Bornzin et al. article. For example, referring back to FIGS. **8A**, **8B**, **9** and **10**, such second measurement photo detector can be located farther from the optical wall **816** than the photo detector **806** shown, as can be appreciated from FIG. **11A**.

In an alternative embodiment, rather than having two spatially separated measurement photo detectors, two light sources (e.g., two 805 nm LEDs) can be spatially separated and time multiplexed, with one light source being closer to the measurement photo detector **806** than the other. In this alternative embodiment, the same ratio $R=IR_{near}/IR_{far}$ can be determined, with the IR_{near} corresponding to scattered light originating from the LED that is closer to the measurement photo detector **806**, and the IR_{far} corresponding to scattered light originated from the LED farther from the measurement photo detector **806**. An example of this is shown in FIG. **11B**, which shows an exemplary layout of elements that can be inserted into a sealed tube **808** (not shown in FIG. **11B**), as described above in the discussion of FIG. **8A**. Using a pair of spatially separated 805 nm light sources is advantageous, as compared to using a pair of spatially separated measurement light detectors, because light sources (such as LEDs) are typically significantly smaller than photo detectors, thus resulting in space savings. As with the previously described embodiments, the calibration photo detector **806** will detect internally reflected light from the near and far light sources **202**, and the measurement photo detector **806** will detect scattered light from the near and far light sources **202**.

Combinations of the above described embodiments that compensated for changes in light intensity are also within the scope of the present invention. For example, it may be that the drive signal **1112** is only increased when the intensity of a light source has decreased by a specific level, and that up to that point a processor performs any necessary compensation algorithmically. This is just one example of how the above described embodiments can be combined, which is not meant to be limiting. It is also noted that the above described embodiments that compensate for changes in the intensity of light produced by one or more implanted light source can also be used with implantable photo plethysmography (PPG) devices, such as, but not limited to those described in the following commonly assigned patents and application, each of which are incorporated herein by reference: U.S. Pat. No. 6,491,639 (Turcott); U.S. Pat. No. 6,561,984 (Turcott); U.S. Pat. No. 6,731,967 (Turcott); U.S. Pat. No. 6,942,622 (Turcott); and U.S. patent application Ser. No. 10/764,419 (Turcott), filed Jan. 23, 2004.

Exemplary Stimulation Device

Referring to FIG. **12A**, the exemplary implantable stimulation device **1210** is shown as being in electrical communication with a patient's heart **1212** by way of three leads, **1220**, **1224** and **1230**, suitable for delivering multi-chamber stimulation and shock therapy. The sensor module **802** of the present invention can be placed within any of these leads, as was described above. Alternatively, a further dedicated lead

or catheter can be provided for the purpose of containing the sensor **802** and placing the sensor **802** at a desired measurement site.

To sense atrial cardiac signals and to provide right atrial chamber stimulation therapy, the stimulation device **1210** is coupled to an implantable right atrial lead **1220** having at least an atrial tip electrode **1222**, which typically is implanted in the patient's right atrial appendage.

To sense left atrial and ventricular cardiac signals and to provide left-chamber pacing therapy, the stimulation device **1210** is coupled to a "coronary sinus" lead **1224** designed for placement in the "coronary sinus region" via the coronary sinus for positioning a distal electrode adjacent to the left ventricle and/or additional electrode(s) adjacent to the left atrium. As used herein, the phrase "coronary sinus region" refers to the vasculature of the left ventricle, including any portion of the coronary sinus, great cardiac vein, left marginal vein, left posterior ventricular vein, middle cardiac vein, and/or small cardiac vein or any other cardiac vein accessible by the coronary sinus.

The exemplary coronary sinus lead **1224** is designed to receive atrial and ventricular cardiac signals and to deliver left ventricular pacing therapy using at least a left ventricular tip electrode **1226**, left atrial pacing therapy using at least a left atrial ring electrode **1227**, and shocking therapy using at least a left atrial coil electrode **1228**.

The stimulation device **1210** is also shown in electrical communication with the patient's heart **1212** by way of an implantable right ventricular lead **1230** having, in this embodiment, a right ventricular tip electrode **1232**, a right ventricular ring electrode **1234**, a right ventricular (RV) coil electrode **1236**, and an SVC coil electrode **1238**. Typically, the right ventricular lead **1230** is transvenously inserted into the heart **1212** so as to place the right ventricular tip electrode **1232** in the right ventricular apex so that the RV coil electrode **1236** will be positioned in the right ventricle and the SVC coil electrode **1238** will be positioned in the superior vena cava. Accordingly, the right ventricular lead **1230** is capable of receiving cardiac signals and delivering stimulation in the form of pacing and shock therapy to the right ventricle.

As illustrated in FIG. **12B**, a simplified block diagram is shown of the multi-chamber implantable stimulation device **1210**, which is capable of treating both fast and slow arrhythmias with stimulation therapy, including cardioversion, defibrillation, and pacing stimulation. While a particular multi-chamber device is shown, this is for illustration purposes only, and one of skill in the art could readily duplicate, eliminate or disable the appropriate circuitry in any desired combination to provide a device capable of treating the appropriate chamber(s) with cardioversion, defibrillation and pacing stimulation.

The housing **1240** for the stimulation device **1210**, shown schematically in FIG. **12B**, is often referred to as the "can", "case" or "case electrode" and may be programmably selected to act as the return electrode for all "unipolar" modes. The housing **1240** may further be used as a return electrode alone or in combination with one or more of the coil electrodes, **1228**, **1236** and **1238**, for shocking purposes. The housing **1240** further includes a connector (not shown) having a plurality of terminals, **1242**, **1244**, **1246**, **1248**, **1252**, **1254**, **1256**, and **1258** (shown schematically and, for convenience, the names of the electrodes to which they are connected are shown next to the terminals).

As such, to achieve right atrial sensing and pacing, the connector includes at least a right atrial tip terminal (AR TIP) **1242** adapted for connection to the atrial tip electrode **1222**.

To achieve left chamber sensing, pacing and shocking, the connector includes at least a left ventricular tip terminal (VL TIP) **1244**, a left atrial ring terminal (AL RING) **1246**, and a left atrial shocking terminal (AL COIL) **1248**, which are adapted for connection to the left ventricular tip electrode **1226**, the left atrial ring electrode **1227**, and the left atrial coil electrode **1228**, respectively.

To support right chamber sensing, pacing and shocking, the connector further includes a right ventricular tip terminal (VR TIP) **1252**, a right ventricular ring terminal (VR RING) **1254**, a right ventricular shocking terminal (RV COIL) **1256**, and an SVC shocking terminal (SVC COIL) **1258**, which are adapted for connection to the right ventricular tip electrode **1232**, right ventricular ring electrode **1234**, the RV coil electrode **1236**, and the SVC coil electrode **1238**, respectively.

The connector is also shown as including terminals **1259** and **1261** (OXYMETRY TERMINALS), which are configured for connection to the wires **914** that are connected to the sensor module **802**, to support the delivery of control signals to the sensor module **802**, and to collect oxymetry data from the sensor module **802**.

At the core of the stimulation device **1210** is a programmable microcontroller **1260** which controls the various modes of stimulation therapy, including pacing optimization and anti-arrhythmia therapy. The microcontroller **1260** can also determine measures of blood oxygen saturation and/or hematocrit based on the signals it receives from an oximetry sensor of the present invention. Such measures of oxygen saturation and/or hematocrit can be used, e.g., for pacing optimization, disease monitoring, and the like. Additionally or alternatively, the measures of oxygen saturation and/or hematocrit can be stored in memory **1294** for later transmission to an external device **1202** using the telemetry circuit **1201**.

If the oxymetry sensor module **802** provides analog signals to the implantable device, then the terminals **1259** and **1261**, through switch **1274**, can provide such signals to an analog-to-digital (A/D) converter **1290** that converts the signals to a digital format understood by the microcontroller **1260**. It is also possible that a dedicated A/D converter be provided within the implantable device **1210** for the purpose of digitizing signals received from the oximetry sensor. If the oxymetry sensor **802** provides digital signals to the implantable device **1210**, then such signals may be provided directly to the microcontroller **1210**, assuming it is the microcontroller **1260** that performs the processing that determines measures of blood oxygen saturation and/or hematocrit based on the signals. It is also possible that the implantable device **1210** include circuitry, external to the microcontroller **1260**, which is dedicated to determining measures of blood oxygen saturation and/or hematocrit.

As is well known in the art, the microcontroller **1260** typically includes a microprocessor, or equivalent control circuitry, designed specifically for controlling the delivery of stimulation therapy and can further include RAM or ROM memory, logic and timing circuitry, state machine circuitry, and I/O circuitry. Typically, the microcontroller **1260** includes the ability to analyze signals (data) as controlled by a program code stored in a designated block of memory. The details of the design of the microcontroller **1260** are not critical to the present invention. Rather, any suitable microcontroller **1260** can be used to carry out the functions described herein. The use of microprocessor-based control circuits for performing timing, control and data analysis functions are well known in the art.

Representative types of control circuitry that may be used with the invention include the microprocessor-based control

system of U.S. Pat. No. 4,940,052 (Mann et. al.) and the state-machines of U.S. Pat. No. 4,712,555 (Thornander et al.) and U.S. Pat. No. 4,944,298 (Sholder). For a more detailed description of the various timing intervals used within the stimulation device and their inter-relationship, see U.S. Pat. No. 4,788,980 (Mann et. al.). The '052, '555, '298 and '980 patents are incorporated herein by reference.

As shown in FIG. **12B**, an atrial pulse generator **1270** and a ventricular pulse generator **1272** generate pacing stimulation pulses for delivery by the right atrial lead **1220**, the right ventricular lead **1230**, and/or the coronary sinus lead **1224** via an electrode configuration switch **1274**. It is understood that in order to provide stimulation therapy in each of the four chambers of the heart, the atrial and ventricular pulse generators, **1270** and **1272**, may include dedicated, independent pulse generators, multiplexed pulse generators, or shared pulse generators. The pulse generators, **1270** and **1272**, are controlled by the microcontroller **1260** via appropriate control signals, **1276** and **1278**, respectively, to trigger or inhibit the stimulation pulses.

The microcontroller **1260** further includes timing control circuitry **1279** which is used to control pacing parameters (e.g., the timing of stimulation pulses) as well as to keep track of the timing of refractory periods, PVARP intervals, noise detection windows, evoked response windows, alert intervals, marker channel timing, etc., which is well known in the art. Examples of pacing parameters include, but are not limited to, atrio-ventricular delay, interventricular delay and interatrial delay.

The switch bank **1274** includes a plurality of switches for connecting the desired electrodes to the appropriate I/O circuits, thereby providing complete electrode programmability. Accordingly, the switch **1274**, in response to a control signal **1280** from the microcontroller **1260**, determines the polarity of the stimulation pulses (e.g., unipolar, bipolar, combipolar, etc.) by selectively closing the appropriate combination of switches (not shown) as is known in the art. The switch **1274** can also be used to connect wires from an oximetry sensor **802** to appropriate I/O circuits.

Atrial sensing circuits **1282** and ventricular sensing circuits **1284** may also be selectively coupled to the right atrial lead **1220**, coronary sinus lead **1224**, and the right ventricular lead **1230**, through the switch **1274** for detecting the presence of cardiac activity in each of the four chambers of the heart. Accordingly, the atrial (ATR. SENSE) and ventricular (VTR. SENSE) sensing circuits, **1282** and **1284**, may include dedicated sense amplifiers, multiplexed amplifiers, or shared amplifiers. The switch **1274** determines the "sensing polarity" of the cardiac signal by selectively closing the appropriate switches, as is also known in the art. In this way, the clinician may program the sensing polarity independent of the stimulation polarity.

Each sensing circuit, **1282** and **1284**, preferably employs one or more low power, precision amplifiers with programmable gain and/or automatic gain control, bandpass filtering, and a threshold detection circuit, as known in the art, to selectively sense the cardiac signal of interest. The automatic gain control enables the device **1210** to deal effectively with the difficult problem of sensing the low amplitude signal characteristics of atrial or ventricular signals.

The outputs of the atrial and ventricular sensing circuits, **1282** and **1284**, are connected to the microcontroller **1260** which, in turn, are able to trigger or inhibit the atrial and ventricular pulse generators, **1270** and **1272**, respectively, in a demand fashion in response to the absence or presence of cardiac activity, in the appropriate chambers of the heart. The sensing circuits, **1282** and **1284**, in turn, receive control sig-

nals over signal lines, **1286** and **1288**, from the microcontroller **1260** for purposes of measuring cardiac performance at appropriate times, and for controlling the gain, threshold, polarization charge removal circuitry (not shown), and timing of any blocking circuitry (not shown) coupled to the inputs of the sensing circuits, **1282** and **1286**.

For arrhythmia detection, the device **1210** utilizes the atrial and ventricular sensing circuits, **1282** and **1284**, to sense cardiac signals to determine whether a rhythm is physiologic or pathologic. The timing intervals between sensed events (e.g., P-waves, R-waves, and depolarization signals associated with fibrillation which are sometimes referred to as “F-waves” or “Fib-waves”) are then classified by the microcontroller **1260** by comparing them to a predefined rate zone limit (i.e., bradycardia, normal, low rate VT, high rate VT, and fibrillation rate zones) and various other characteristics (e.g., sudden onset, stability, physiologic sensors, and morphology, etc.) in order to assist with determining the type of remedial therapy that is needed (e.g., bradycardia pacing, anti-tachycardia pacing, cardioversion shocks or defibrillation shocks, collectively referred to as “tiered therapy”).

Cardiac signals are also applied to the inputs of an analog-to-digital (A/D) data acquisition system **1290**. The data acquisition system **1290** is configured to acquire intracardiac electrogram signals, convert the raw analog data into a digital signal, and store the digital signals for later processing and/or telemetric transmission to an external device **1202**. The data acquisition system **1290** is coupled to the right atrial lead **1220**, the coronary sinus lead **1224**, and the right ventricular lead **1230** through the switch **1274** to sample cardiac signals across any pair of desired electrodes.

Advantageously, the data acquisition system **1290** can be coupled to the microcontroller **1260**, or other detection circuitry, for detecting an evoked response from the heart **1212** in response to an applied stimulus, thereby aiding in the detection of “capture”. Capture occurs when an electrical stimulus applied to the heart is of sufficient energy to depolarize the cardiac tissue, thereby causing the heart muscle to contract. The microcontroller **1260** detects a depolarization signal during a window following a stimulation pulse, the presence of which indicates that capture has occurred. The microcontroller **1260** enables capture detection by triggering the ventricular pulse generator **1272** to generate a stimulation pulse, starting a capture detection window using the timing control circuitry **1279** within the microcontroller **1260**, and enabling the data acquisition system **1290** via control signal **1292** to sample the cardiac signal that falls in the capture detection window and, based on the amplitude, determines if capture has occurred.

The implementation of capture detection circuitry and algorithms are well known. See for example, U.S. Pat. No. 4,729,376 (Decote, Jr.); U.S. Pat. No. 4,708,142 (Decote, Jr.); U.S. Pat. No. 4,686,988 (Sholder); U.S. Pat. No. 4,969,467 (Callaghan et. al.); and U.S. Pat. No. 5,350,410 (Kleks et. al.), which patents are hereby incorporated herein by reference. The type of capture detection system used is not critical to the present invention.

The microcontroller **1260** is further coupled to a memory **1294** by a suitable data/address bus **1296**, wherein the programmable operating parameters used by the microcontroller **1260** are stored and modified, as required, in order to customize the operation of the stimulation device **1210** to suit the needs of a particular patient. Such operating parameters define, for example, pacing pulse amplitude, pulse duration, electrode polarity, rate, sensitivity, automatic features, arrhythmia detection criteria, and the amplitude, waveshape

and vector of each shocking pulse to be delivered to the patient’s heart **1212** within each respective tier of therapy.

Data acquired by the data acquisition system **1290** (and optionally stored) can be used for subsequent analysis to guide the programming of the device and/or to monitor oxygen saturation and/or hematocrit, appropriately adjust pacing interval parameters, select optimum pacing intervals, and/or select appropriate anti-arrhythmia therapy.

Advantageously, the operating parameters of the implantable device **1210** may be non-invasively programmed into the memory **1294** through a telemetry circuit **1201** in telemetric communication with the external device **1202**, such as a programmer, transtelephonic transceiver, or a diagnostic system analyzer. The telemetry circuit **1201** is activated by the microcontroller by a control signal **1206**. The telemetry circuit **1201** advantageously allows intracardiac electrograms, oxygen saturation information, hematocrit information and status information relating to the operation of the device **1210** (as contained in the microcontroller **1260** or memory **1294**) to be sent to an external device **1202** through an established communication link **1204**.

For examples of such devices, see U.S. Pat. No. 4,809,697, entitled “Interactive Programming and Diagnostic System for use with Implantable Pacemaker” (Causey, III et al.); U.S. Pat. No. 4,944,299, entitled “High Speed Digital Telemetry System for Implantable Device” (Silvian); and U.S. Pat. No. 6,275,734 entitled “Efficient Generation of Sensing Signals in an Implantable Medical Device such as a Pacemaker or ICD” (note: this relates to transfer of EGM data) (McClure et al.), which patents are hereby incorporated herein by reference.

The stimulation device **1210** can further include one or more physiologic sensors **1208**, which can be located within the stimulation device housing **1240** as shown, or can be located external to the housing.

The stimulation device **1210** additionally includes a battery **1212** which provides operating power to all of the circuits shown in FIG. **12B**. For the stimulation device **1210**, which employs shocking therapy, the battery **1212** must be capable of operating at low current drains for long periods of time, and then be capable of providing high-current pulses (for capacitor charging) when the patient requires a shock pulse. The battery **1212** should also have a predictable discharge characteristic so that elective replacement time can be detected. Accordingly, the device **1210** preferably employs lithium/silver vanadium oxide batteries, but is not limited thereto.

The stimulation device **1210** can further include a magnet detection circuitry (not shown), coupled to the microcontroller **1260**. It is the purpose of the magnet detection circuitry to detect when a magnet is placed over the stimulation device **1210**, which magnet may be used by a clinician to perform various test functions of the stimulation device **1210** and/or to signal the microcontroller **1260** that the external programmer **1202** is in place to receive or transmit data to the microcontroller **1260** through the telemetry circuits **1201**.

As further shown in FIG. **12B**, the device **1210** is shown as having an impedance measuring circuit **1213** which is enabled by the microcontroller **1260** via a control signal **1214**. The known uses for an impedance measuring circuit **1213** include, but are not limited to, lead impedance surveillance during the acute and chronic phases for proper lead positioning or dislodgement; detecting operable electrodes and automatically switching to an operable pair if dislodgement occurs; measuring respiration or minute ventilation; measuring thoracic impedance for determining shock thresholds; measuring thoracic impedance for detecting and assessing the severity of pulmonary edema; detecting when the

device has been implanted; measuring stroke volume; and detecting the opening of heart valves, etc. The impedance measuring circuit **1213** is advantageously coupled to the switch **1274** so that any desired electrode may be used. In addition, to facilitate the measurement of peripheral tissue edema, extra electrodes can be added to the device housing, thereby limiting the test electric field to the peripheral tissue.

In the case where the stimulation device **1210** is also intended to operate as an implantable cardioverter/defibrillator (ICD) device, it must detect the occurrence of an arrhythmia, and automatically apply an appropriate electrical shock therapy to the heart aimed at terminating the detected arrhythmia. To this end, the microcontroller **1260** further controls a shocking circuit **1216** by way of a control signal **1218**. The shocking circuit **1216** generates shocking pulses of low (up to 0.5 Joules), moderate (0.5-10 Joules), or high energy (12 to 40 Joules), as controlled by the microcontroller **1260**. Such shocking pulses are applied to the patient's heart **1212** through at least two shocking electrodes, and as shown in this embodiment, selected from the left atrial coil electrode **1228**, the RV coil electrode **1236**, and/or the SVC coil electrode **1238**. As noted above, the housing **1240** may act as an active electrode in combination with the RV electrode **1236**, or as part of a split electrical vector using the SVC coil electrode **1238** or the left atrial coil electrode **1228** (i.e., using the RV electrode as a common electrode).

Cardioversion shocks are generally considered to be of low to moderate energy level (so as to minimize pain felt by the patient), and/or synchronized with an R-wave and/or pertaining to the treatment of tachycardia. Defibrillation shocks are generally of moderate to high energy level (i.e., corresponding to thresholds in the range of 5-40 Joules), delivered asynchronously (since R-waves may be too disorganized to be recognize), and pertaining exclusively to the treatment of ventricular fibrillation. Accordingly, the microcontroller **1260** is capable of controlling the synchronous or asynchronous delivery of the shocking pulses. Another approach to electrical anti-arrhythmia therapy is anti-tachycardia pacing, in which low-voltage pacing pulses are applied to pace-terminate the arrhythmia. This approach is particularly effective in low rate ventricular tachycardias.

The previous description of the preferred embodiments is provided to enable any person skilled in the art to make or use the embodiments of the present invention. While the invention has been particularly shown and described with reference to preferred embodiments thereof, it will be understood by those skilled in the art that various changes in form and details may be made therein without departing from the spirit and scope of the invention.

What is claimed is:

1. An implantable system, comprising:

an implantable housing comprising a window through which light can pass;

at least one light source, within said housing, each of which transmits light of a corresponding wavelength, wherein an intensity of the light transmitted by each said light source is controlled by a corresponding drive signal that drives said light source, and wherein a portion of the light of each said wavelength exits said housing through said window;

a measurement light detector, within said housing, to detect light of each said wavelength scattered back into said housing through said window, and to produce a measurement signal that is indicative of the intensity of the light of each said wavelength detected by said measurement light detector;

an opaque wall that separates said at least one light source from said measurement light detector;

a calibration light detector, within said housing on a same side of said opaque wall as said at least one light source, to detect a portion of the light of each said wavelength that has not exited said housing and has been reflected toward said calibration light detector without using a beam splitter, and to produce a calibration signal that is indicative of the intensity of the light of each said wavelength detected by said calibration light detector, which is indicative of the intensity of the light transmitted by each said light source; and

circuitry operative to detect changes in the intensity of the light transmitted by each said light source based on the calibration signal;

wherein said housing has an inner surface, a first portion of said inner surface coated with a reflective material to cause a portion of the light of each said wavelength that has not exited said housing to be reflected toward said calibration light detector, and a second portion of said inner surface not coated with the reflective material and corresponding to said window through which a portion of the light of each said wavelength exits said housing.

2. The system of claim **1**, wherein said at least one light source comprises a single light source.

3. The system of claim **1**, wherein said at least one light source comprises a first light source that transmits light of a first wavelength and a second light source that transmits light of a second wavelength.

4. The system of claim **3**, wherein said at least one light source comprises a first, a second and a third light source, that transmit, respectively, light of a first wavelength, light of a second wavelength, and light of a third wavelength.

5. The system of claim **1**, wherein said at least one light source comprises first and second spatially separated light sources that transmit light of about 805 nm, wherein said first light source is located closer to said measurement light detector than said second light source.

6. The system of claim **1**, wherein the circuitry comprises a processor, state machine or random logic.

7. The system of claim **1**, further comprising a processor configured to use the measurement signal to determine levels of blood oxygen saturation.

8. The system of claim **1**, further comprising a processor configured to use the measurement signal to determine levels of hematocrit.

9. The system of claim **1**, further comprising a processor configured to use the measurement signal to determine levels of blood oxygen saturation and levels of hematocrit.

10. The system of claim **1**, wherein:

said opaque wall that separates said at least one light source from said measurement light detector prevents said measurement light detector from detecting internally reflected light or light transmitted directly from said at least one light source; and

said opaque wall does not prevent said calibration light detector from detecting internally reflected light or light transmitted directly from said at least one light source.

11. The system of claim **1**, further comprising:

a substrate within said housing;

wherein said at least one light source and said calibration light detector are all attached to said substrate.

12. An implantable system, comprising:

an implantable housing including a window through which light can pass;

at least one light source, within said housing, each of which transmits light of a corresponding wavelength, and

21

wherein a portion of the light of each said wavelength exits said housing through said window without being beam split;

a measurement light detector, within said housing, to detect light of each said wavelength scattered back into said housing through said window, and to produce a measurement signal that is indicative of the intensity of the light of each said wavelength detected by said measurement light detector;

an opaque wall that separates said at least one light source from said measurement light detector;

a calibration light detector positioned generally adjacent to said at least one light source, within said housing, on a same side of said opaque wall as said at least one light source; and

wherein a further portion of light of each said wavelength transmitted by said at least one light source is reflected so that it does not exit said housing and is detected by said calibration light detector, in response to which said calibration light detector produces a calibration signal that is indicative of the intensity of the light of each said wavelength detected by said calibration light detector, which is indicative of the intensity of the light transmitted by each said light source; and

wherein said housing has an inner surface, a first portion of said inner surface coated with a reflective material to cause a portion of the light of each said wavelength that has not exited said housing to be reflected toward said calibration light detector, and a second portion of said inner surface not coated with the reflective material and corresponding to said window through which a portion of the light of each said wavelength exits said housing.

13. The system of claim **12**, further comprising:
a controller to adjust the measurement signal, based on the calibration signal, to compensate for changes in the intensity of the light transmitted by each said light source;

wherein said controller adjusts amplification of the measurement signal to compensate for changes in the intensity of each said light source due to aging of said light source.

14. The system of claim **12**, further comprising:
a controller to adjust the measurement signal, based on the calibration signal, to compensate for changes in the intensity of the light transmitted by each said light source;

wherein said controller adjusts amplification by adjusting gain of an amplifier that amplifies the measurement signal.

15. The system of claim **12**, further comprising:
a substrate within said housing;
wherein said at least one light source and said calibration light detector are all attached to said substrate.

16. The implantable system of claim **12**, further comprising:
a controller to compensate for changes in the intensity of the transmitted light, based on the calibration signal.

22

17. For use in an implantable system, a method for compensating for changes in intensity of light transmitted by a light source of the implantable system, where the light source is contained within a housing having a window, the method comprising:

driving the light source with a drive signal to transmit light having an intensity that is controlled by the drive signal;

allowing a portion of the light transmitted by the light source to pass unsplit toward the window and out of the housing through the window, the window corresponding to a portion of an inner surface of the housing that is not coated by a reflective material;

detecting light scattered by blood;

producing, based on the detected light scattered by blood, a measurement signal indicative of the intensity of the detected light scattered by blood;

reflecting a further portion of the light toward a calibration detector generally adjacent to the light source, using a further portion of the inner surface of the housing that is coated with a reflective material, and detecting, without the use of a beam splitter, the further portion of the light transmitted by the light source that has not exited the housing within which the light source is contained;

producing a calibration signal that is indicative of the intensity of the detected light that has not exited the housing, which is indicative of the intensity of the light transmitted by the light source; and

compensating for changes in the intensity of the transmitted light, based on the calibration signal;

wherein the detecting of the further portion of the light is done using the calibration light detector that is on a same side of an opaque wall as the light source; and

wherein the detecting of the light scattered by blood is done using a measurement light detector that is on an opposite side of the opaque wall from the light source.

18. The method of claim **17**, wherein the compensating step includes adjusting the drive signal, based on the calibration signal, to keep the intensity of the light transmitted by the light source substantially constant.

19. The method of claim **17**, wherein the compensating step includes:
detecting changes in the intensity of the light transmitted by the light source based on the calibration signal; and
taking into account the detected changes in the intensity of the transmitted light when using the measurement signal for a diagnostic and/or therapeutic purpose.

20. The method of claim **19**, further comprising using the measurement signal to determine levels of blood oxygen saturation and/or levels of hematocrit, wherein the detected changes in the intensity of the transmitted light are taken into account when using the measurement signal to determine levels of blood oxygen saturation and/or levels of hematocrit.

21. The method of claim **17**, wherein the compensating step includes adjusting the measurement signal, based on the calibration signal, to compensate for changes in the intensity of the light transmitted by the light source.

* * * * *