



US007830671B2

(12) **United States Patent**
Nuovo

(10) **Patent No.:** **US 7,830,671 B2**
(45) **Date of Patent:** **Nov. 9, 2010**

(54) **CASING**

(75) Inventor: **Frank Nuovo**, Los Angeles, CA (US)

(73) Assignee: **Vertu Limited**, London (GB)

(*) Notice: Subject to any disclaimer, the term of this patent is extended or adjusted under 35 U.S.C. 154(b) by 2062 days.

(21) Appl. No.: **10/451,704**

(22) PCT Filed: **Dec. 26, 2001**

(86) PCT No.: **PCT/US01/49321**

§ 371 (c)(1),
(2), (4) Date: **Dec. 12, 2003**

(87) PCT Pub. No.: **WO02/054718**

PCT Pub. Date: **Jul. 11, 2002**

(65) **Prior Publication Data**

US 2004/0096054 A1 May 20, 2004

(30) **Foreign Application Priority Data**

Dec. 29, 2000 (GB) 0031787.5

(51) **Int. Cl.**
H05K 7/14 (2006.01)

(52) **U.S. Cl.** **361/797**; 361/752

(58) **Field of Classification Search** 361/790,
361/797, 800; 345/169; 455/575
See application file for complete search history.

(56) **References Cited**

U.S. PATENT DOCUMENTS

- 3,946,171 A 3/1976 Kuhfus 200/5 R
- 5,362,932 A * 11/1994 Inagaki et al. 200/341
- 5,372,441 A 12/1994 Louis 400/489
- 5,455,556 A * 10/1995 Ohm et al. 338/114
- 5,503,484 A 4/1996 Louis 400/489

- 5,768,370 A 6/1998 Maatta et al.
- 5,866,252 A * 2/1999 de Rochemont et al. 428/373
- 6,016,423 A 1/2000 Ross et al. 455/90
- 6,031,732 A 2/2000 Koike et al. 361/816
- 6,058,293 A * 5/2000 Phillips 455/575.1
- 6,164,853 A 12/2000 Foote 400/489
- 6,388,870 B1 * 5/2002 Canova et al. 361/683
- 6,445,577 B1 * 9/2002 Madsen et al. 361/683
- 6,480,377 B2 * 11/2002 Genest et al. 361/686
- 6,496,181 B1 * 12/2002 Bomer et al. 345/167
- 6,571,188 B1 * 5/2003 Clarridge et al. 702/104
- 6,771,938 B2 * 8/2004 Lustila et al. 455/575.1
- 6,868,259 B1 3/2005 Kitamura et al. 455/903
- 6,904,300 B1 * 6/2005 Maattanen et al. 455/575.1
- 2002/0159586 A1 * 10/2002 Chiou 379/433.11

FOREIGN PATENT DOCUMENTS

DE 29904922 U1 5/2000

(Continued)

OTHER PUBLICATIONS

Digital Communication, TCL999D, Dec. 2000, 3 pages.

(Continued)

Primary Examiner—Hung S Bui
(74) *Attorney, Agent, or Firm*—Harrington & Smith

(57) **ABSTRACT**

The invention relates to the casings for portable communications devices. In particular the invention provides a casing formed from precious materials.

19 Claims, 19 Drawing Sheets

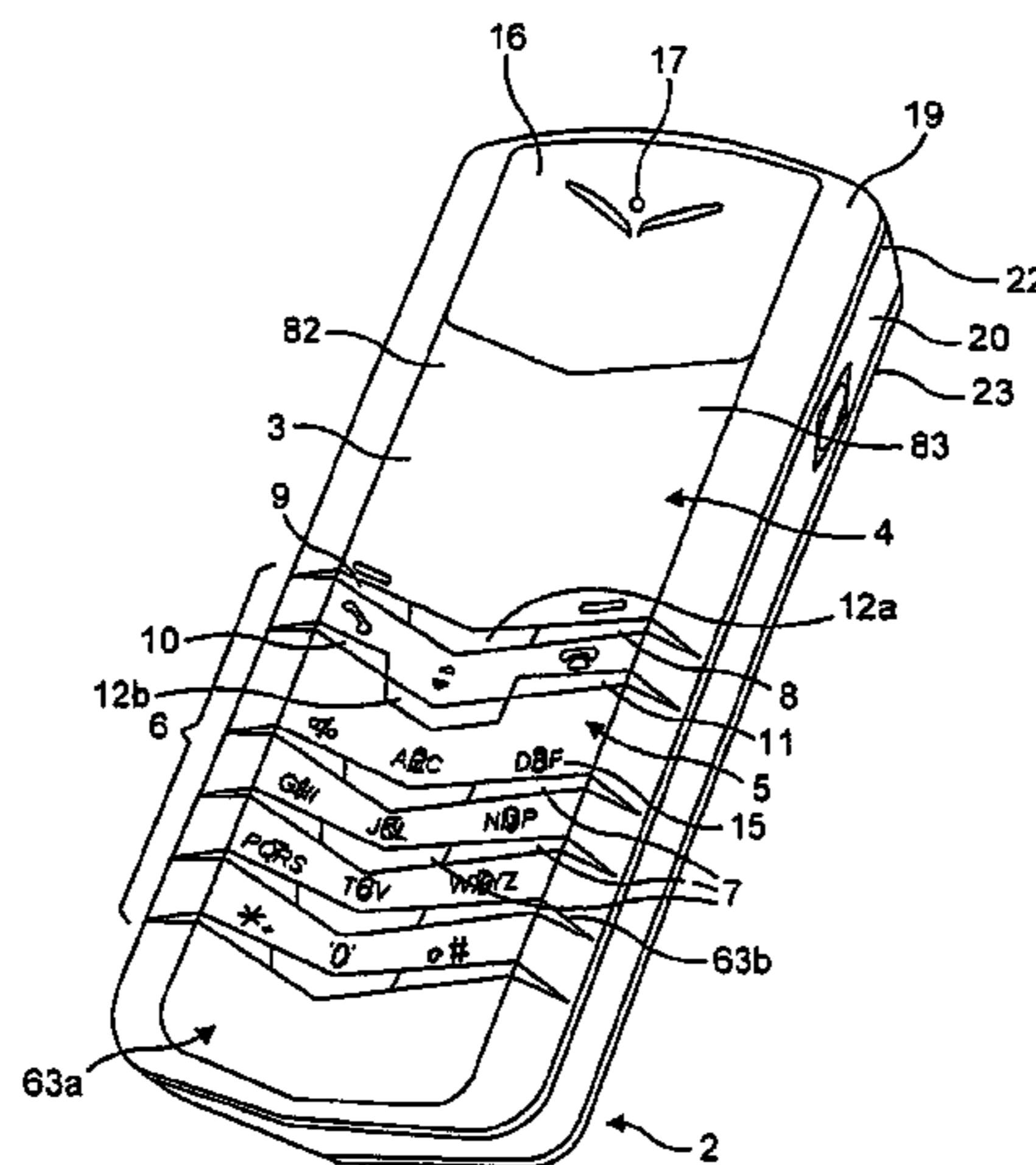

FOREIGN PATENT DOCUMENTS		
DE	20014882	U1 2/2001
EP	01/02087	B1 12/1986
EP	0790584	A2 8/1997
EP	09/32288	A1 7/1999
EP	1 017 209	A2 7/2000
EP	1026868	A1 8/2000
EP	1 017 209	A3 8/2003
FR	2 737 837	2/1997
GB	2293517	A 3/1996
GB	2301945	A 12/1996
GB	2318476	A 4/1998
GB	2331888	A 6/1999
GB	2339993	A 2/2000
GB	2343972	A 5/2000
GB	2346759	A 8/2000
JP	09-008690	1/1997
JP	10-251602	9/1998
JP	10-304034	11/1998
WO	WO 92/01250	1/1992
WO	WO-92/01250	A1 1/1992
WO	WO 98/05148	2/1998
WO	WO-00/77666	A2 12/2000
WO	WO-01/24072	A1 4/2001
WO	WO-01/43577	A2 6/2001

WO WO-02/41194 A2 5/2002

OTHER PUBLICATIONS

Patent Abstracts of Japan, Kanagata Mukawa:KK, No. 2000036704, Pub'd Feb. 2, 2000.

Patent Abstracts of Japan, Kawai Musical Instr, No. 10304037, Pub'd Nov. 13, 1998.

Patent Abstracts of Japan, Daidoji Yasuo, No. 2000295329, Pub'd Oct. 20, 2000.

Motorola v3688, "the little stunner in Gold", Products online at <http://www.aloisson.com/prode.html>) Peter Aloisson Luxury Phones, 1999.

"Sony Ericsson to offer luxury cell phones . . . ", Feb. 4, 2002, retrieved from internet <http://www.silicon.ie/snews3.shtml> #five, 1page.

"Peter Aloisson All shine & Sparkle", 2003, retrieved from the internet, <http://www.aloisson.com/start.html>, 3 pages.

"How to Replace Old Casing of an Old Mobile Phone with a New One (with English translation)", © 1994-2008 China Academic Journal Electronic Publishing House, Digital Communication, 4 pgs. translated.

Batista, Elisa, "The Jewel of Cell Phones", Wired News (online) Jan. 31, 2001.

* cited by examiner

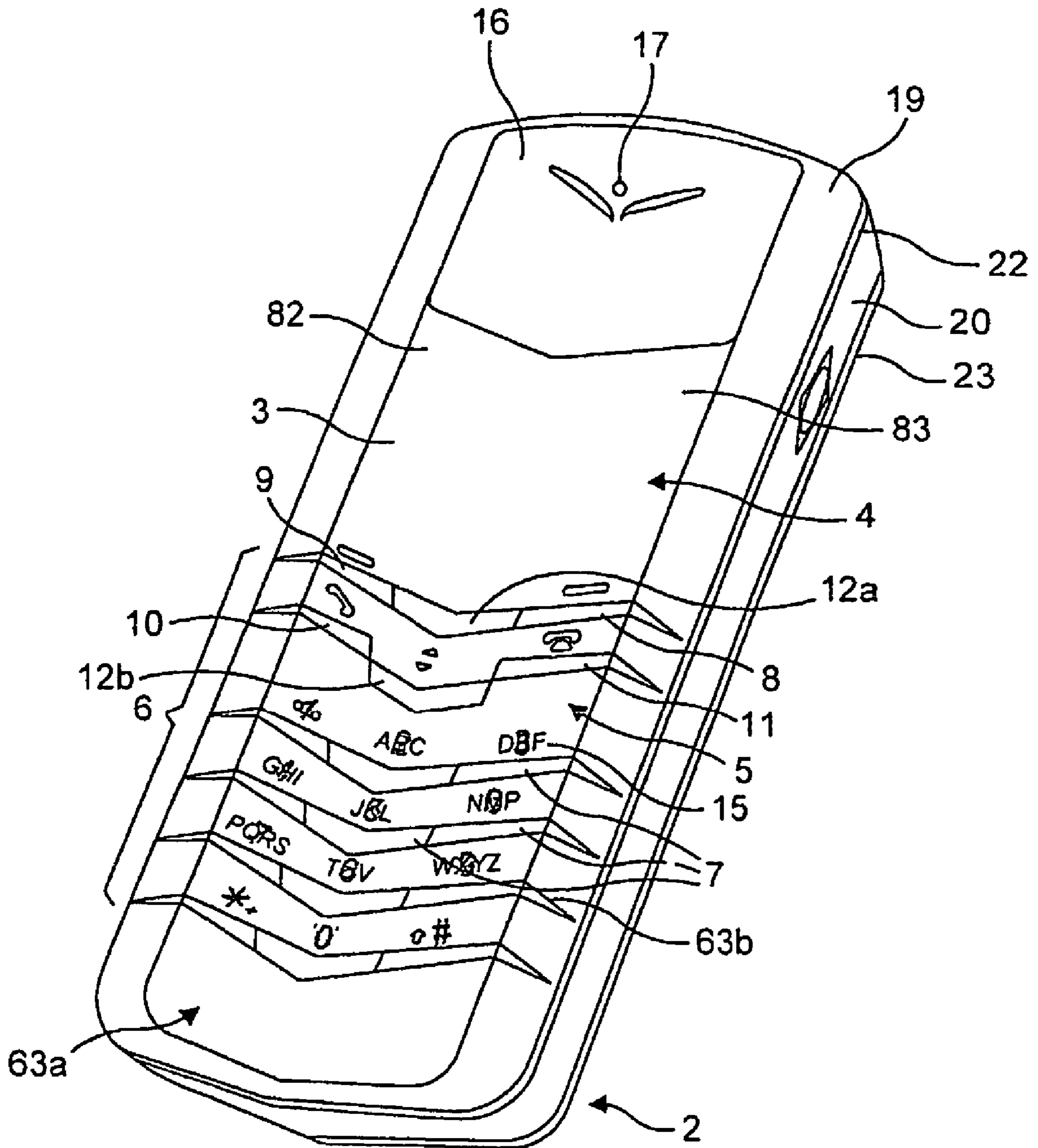

FIG. 1

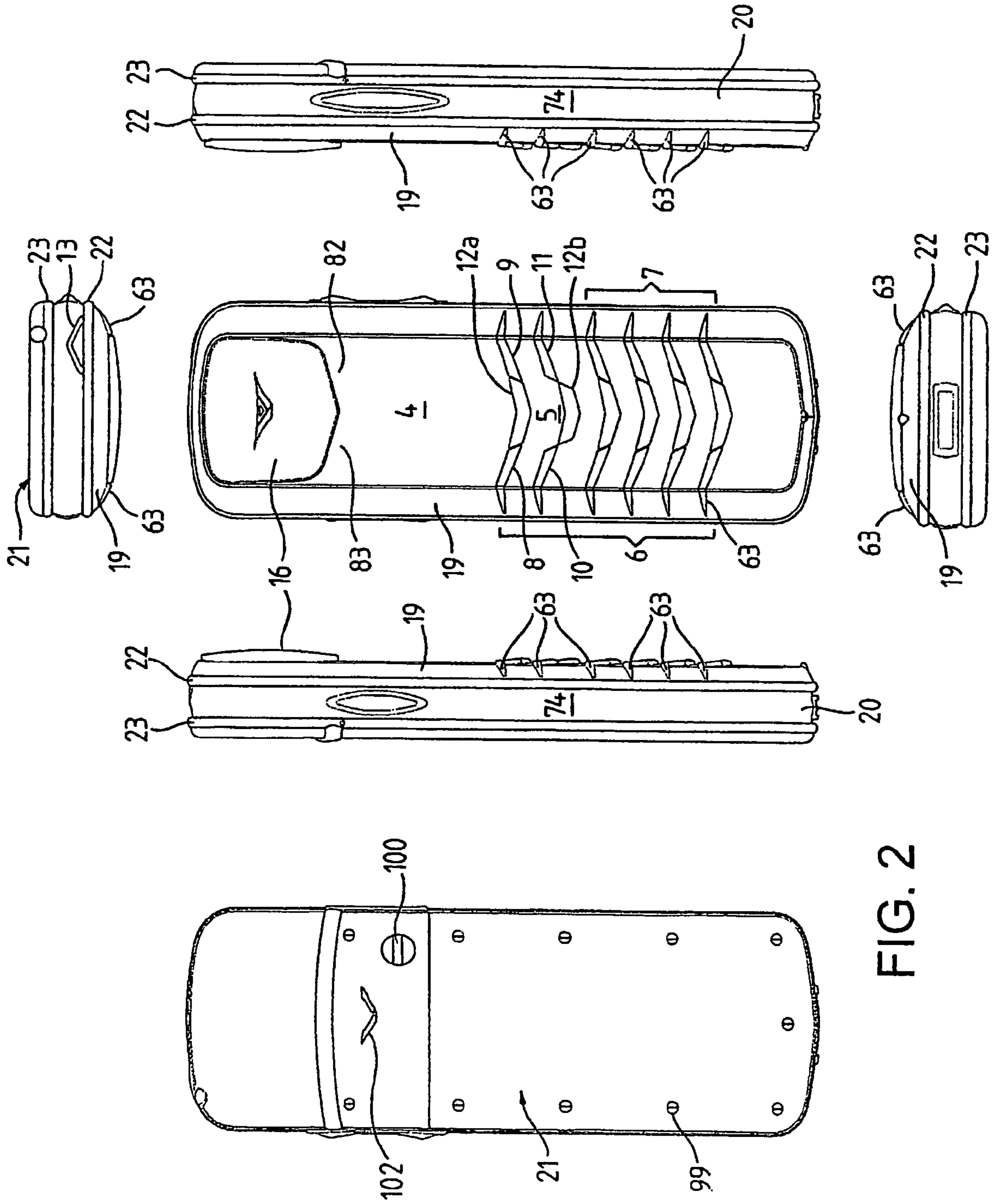

FIG. 2

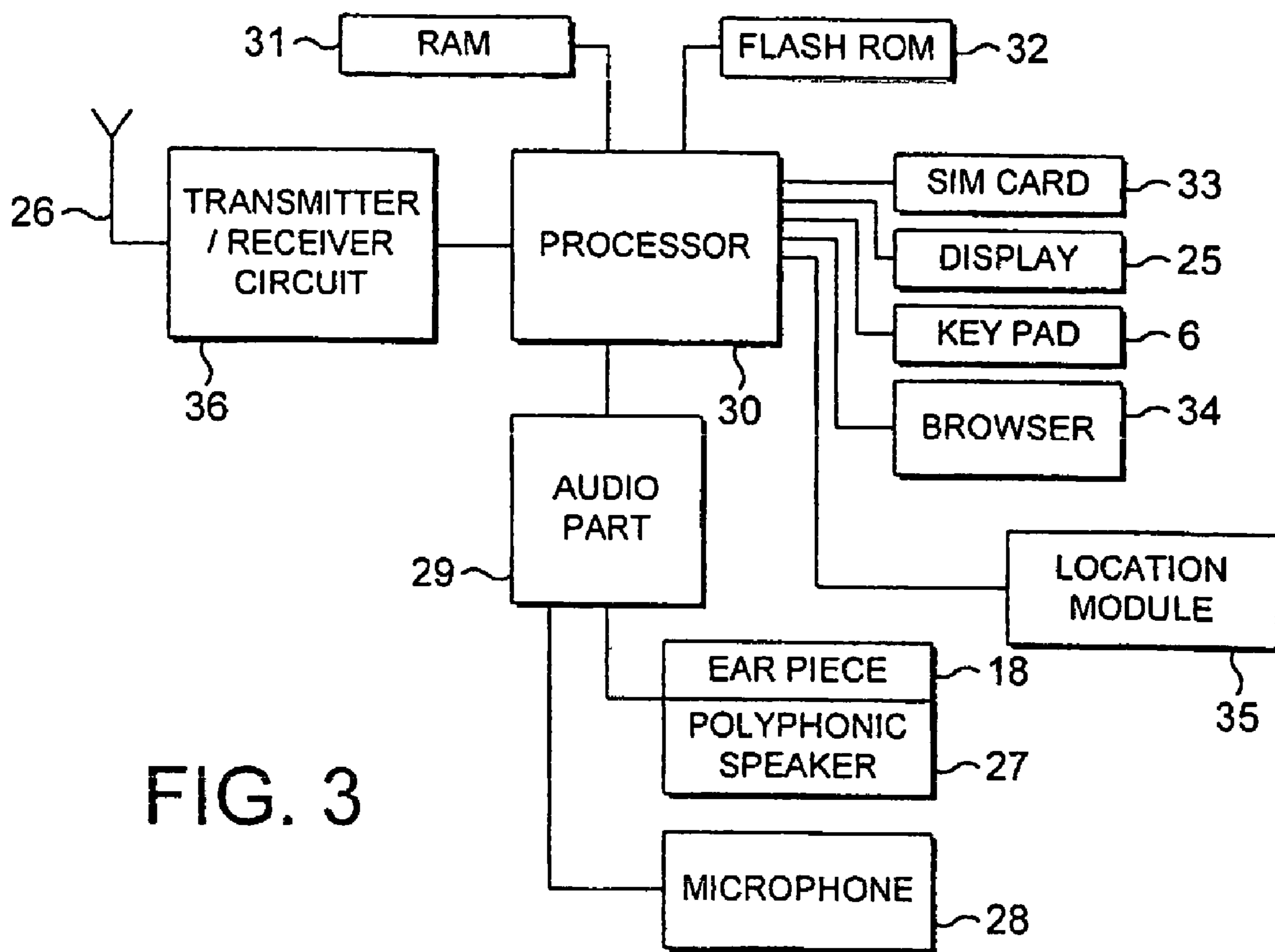

FIG. 3

FIG. 4

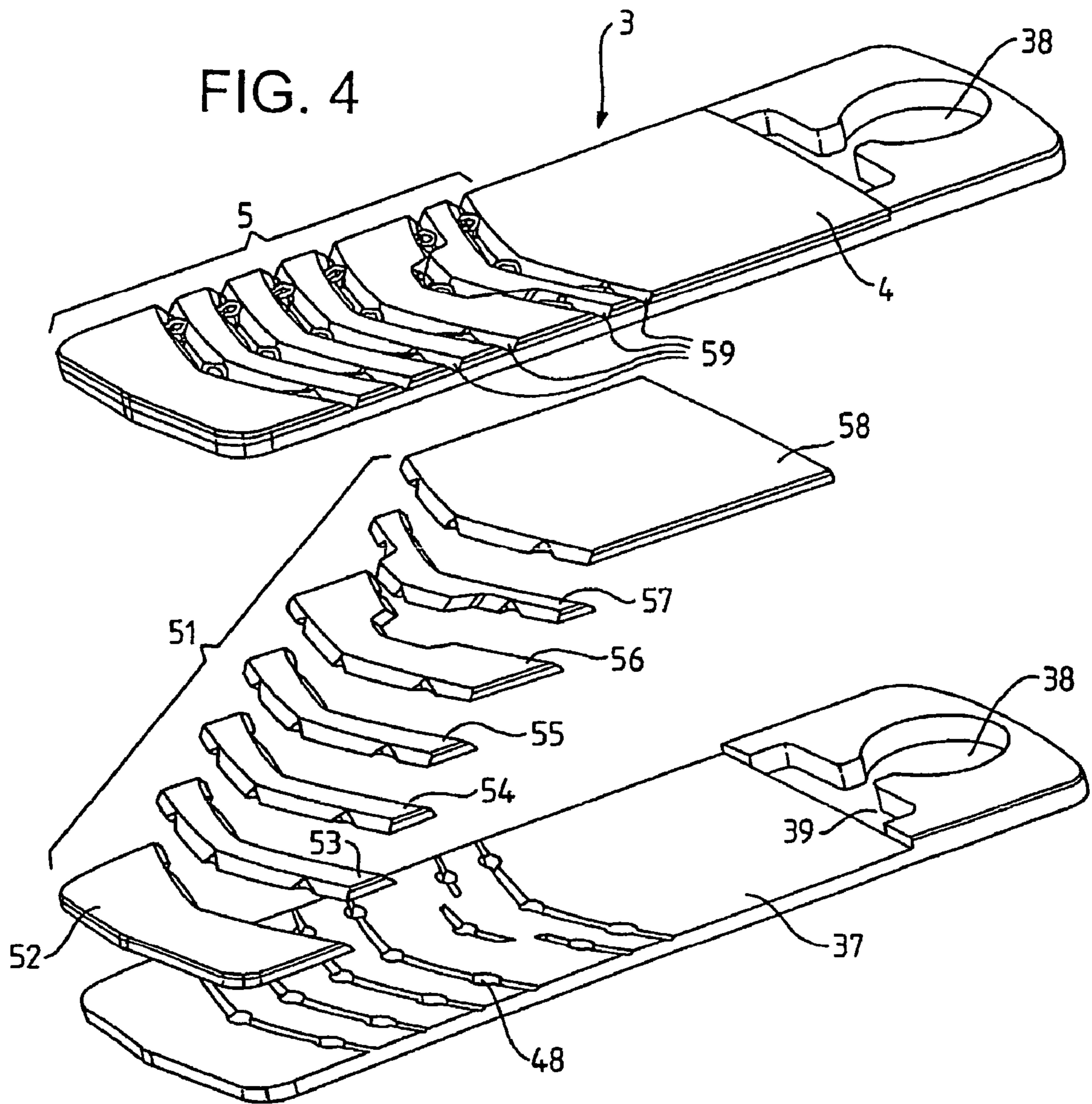
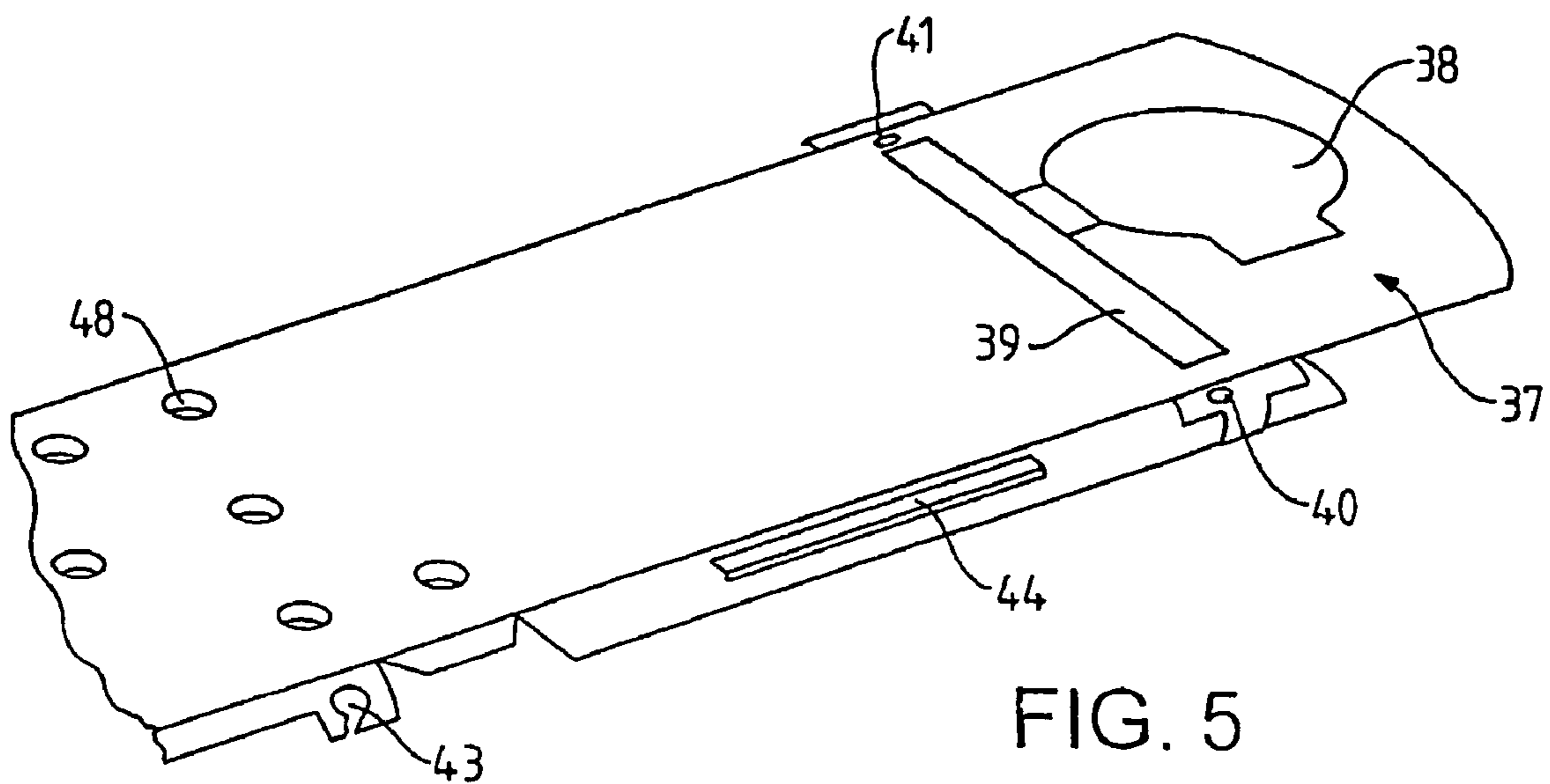

FIG. 5



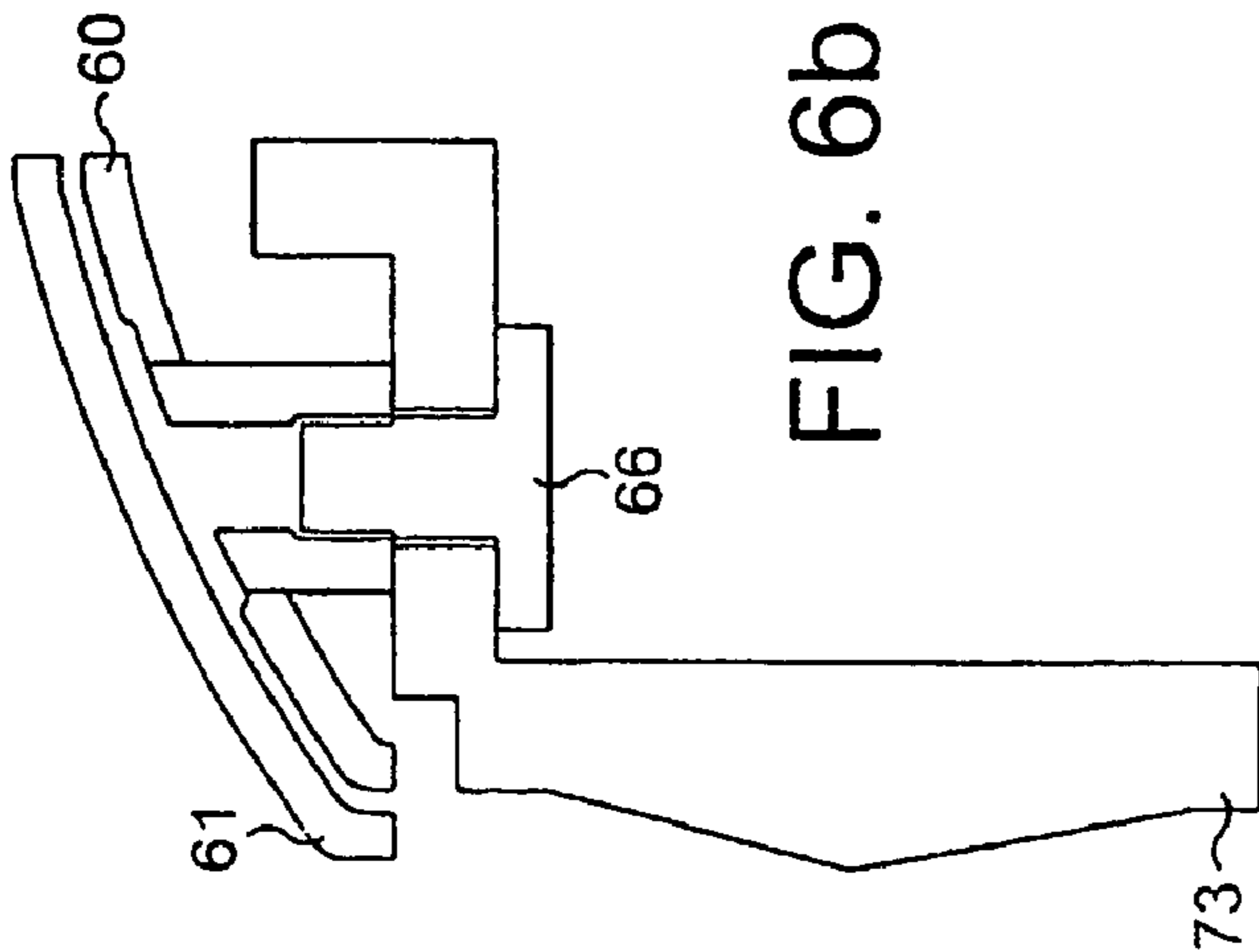

FIG. 6b

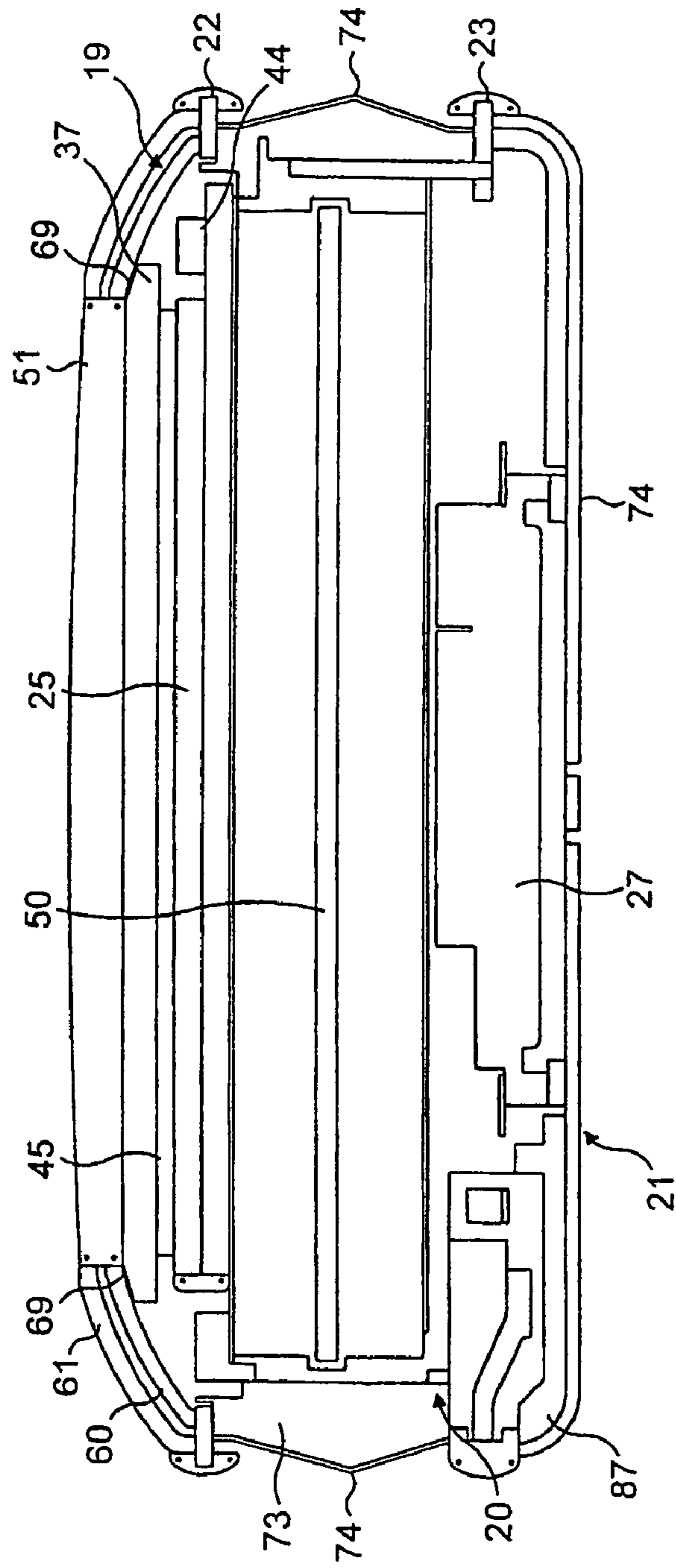

FIG. 6a

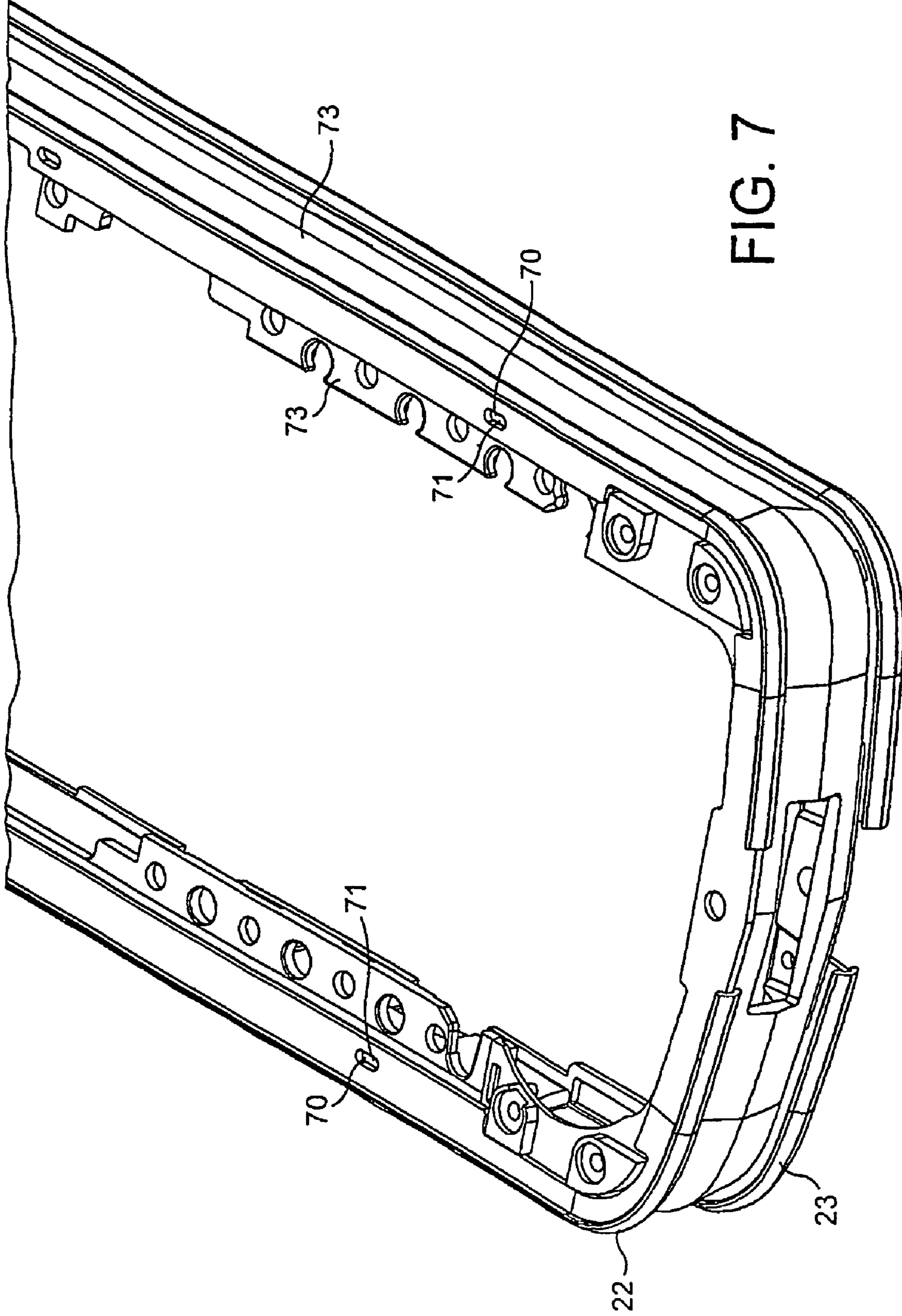

FIG. 7

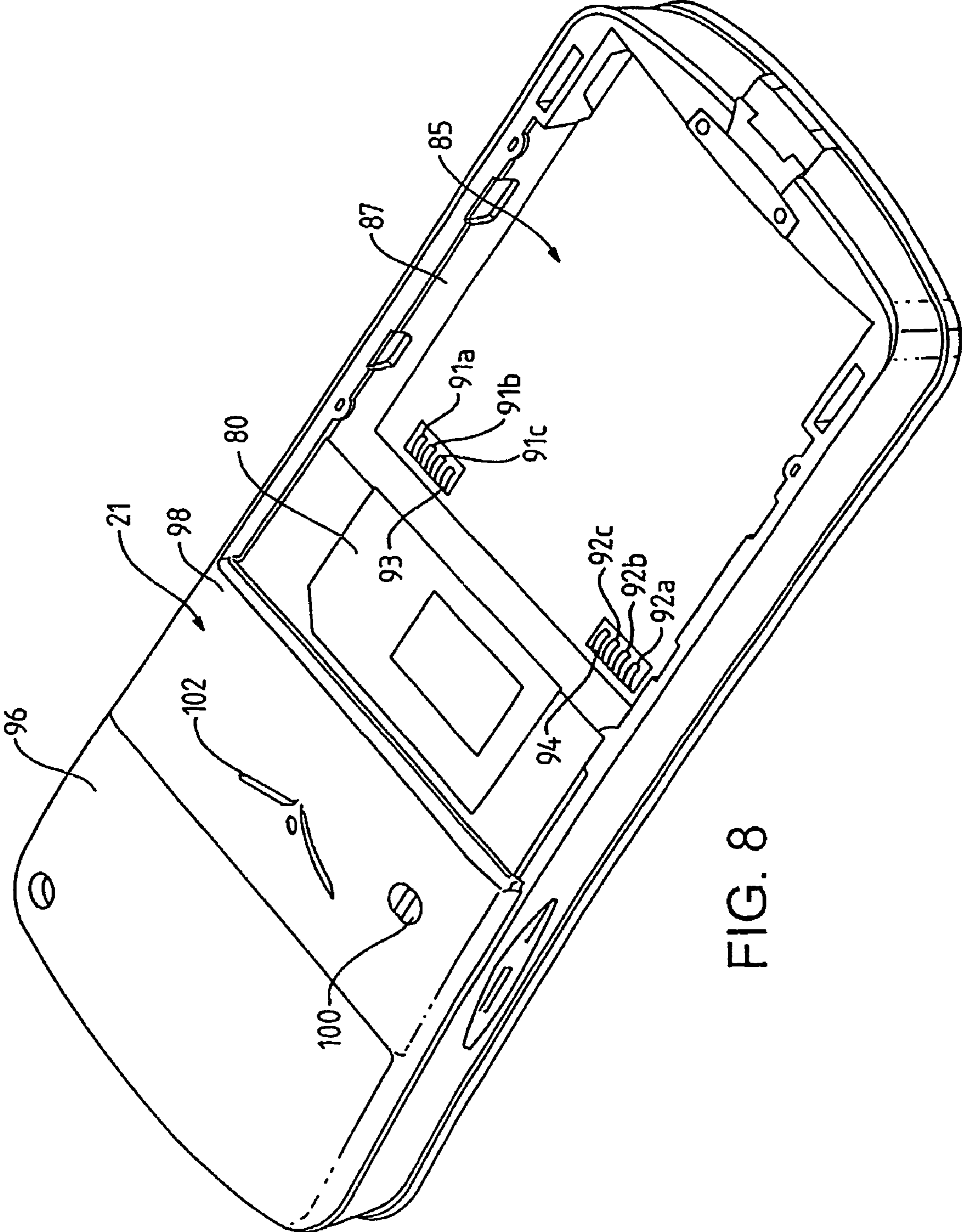

FIG. 8

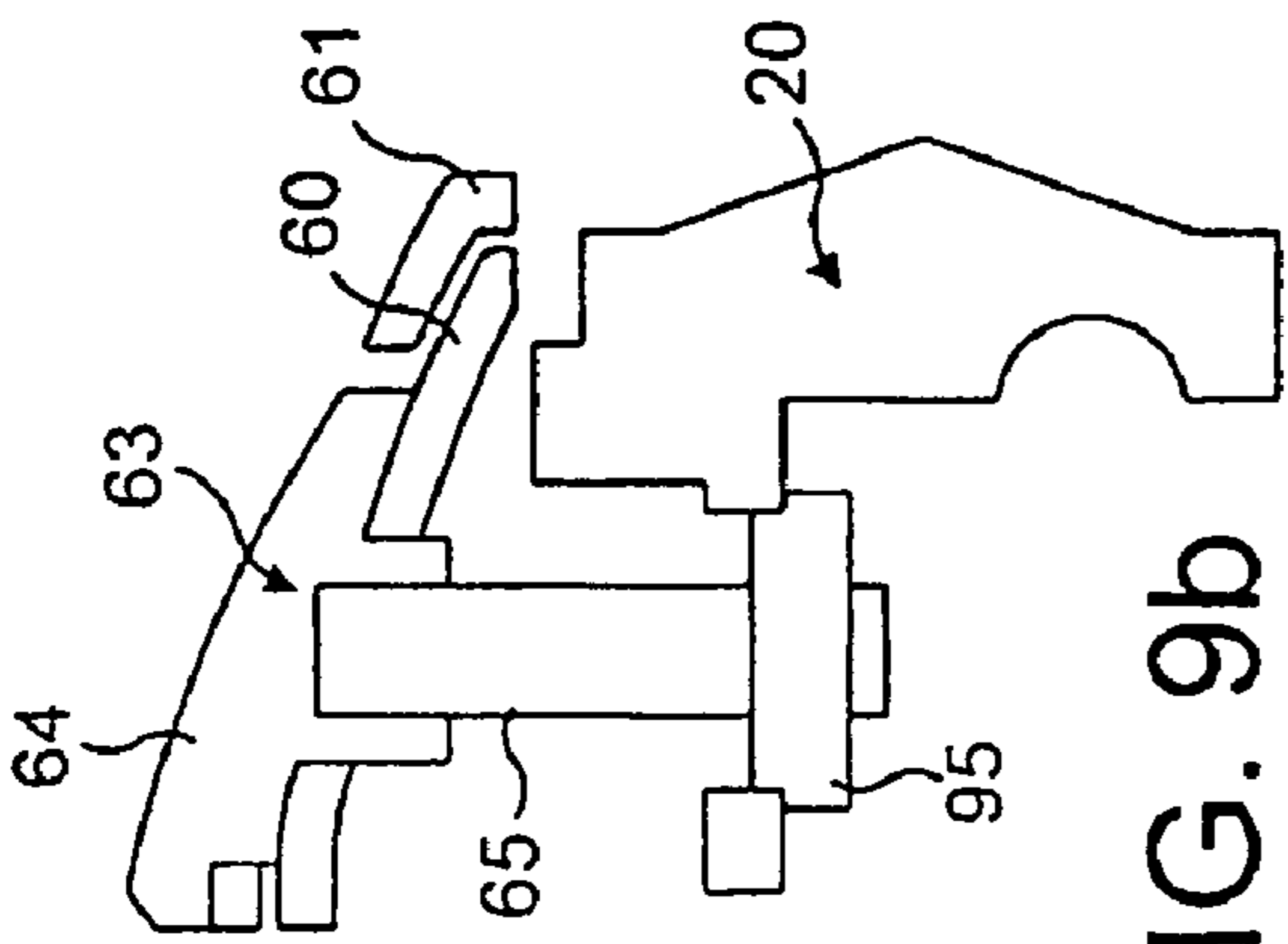

FIG. 9b

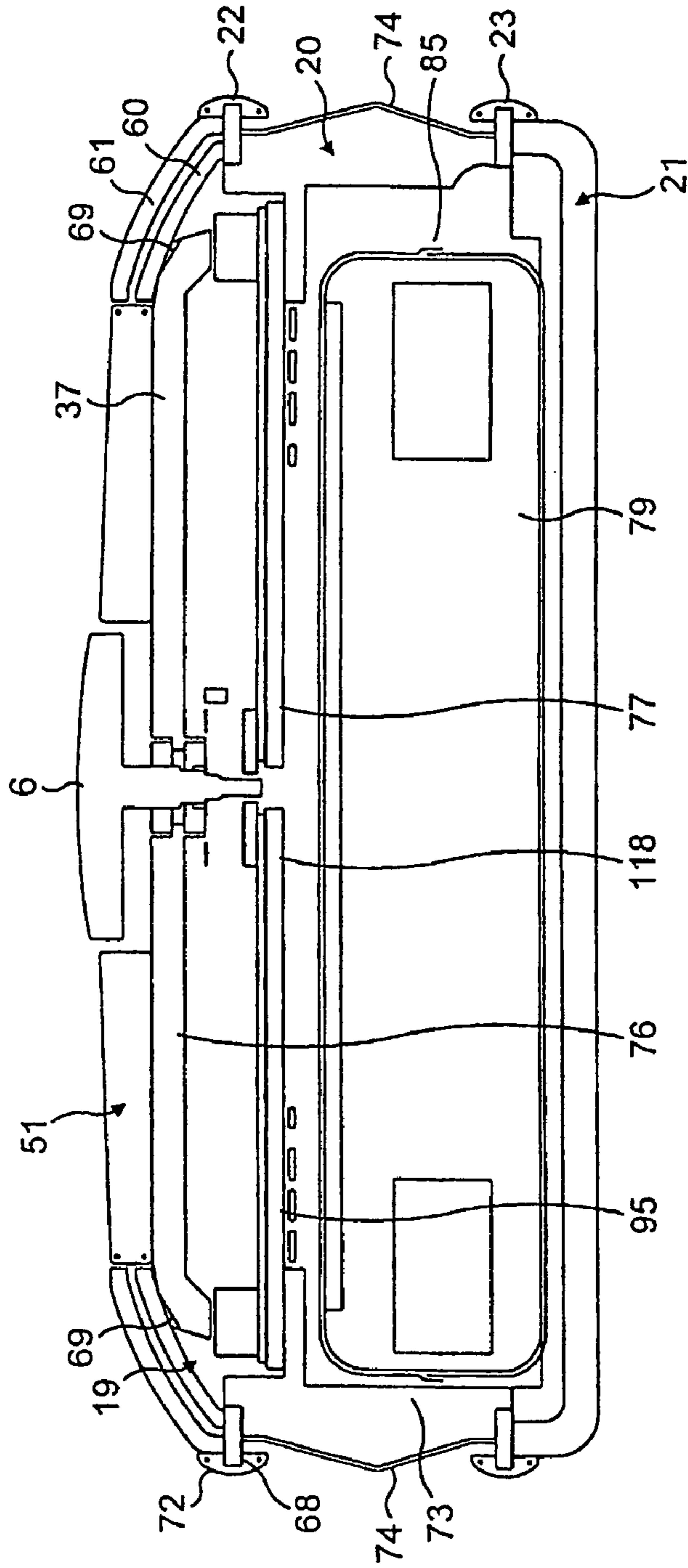

FIG. 9a

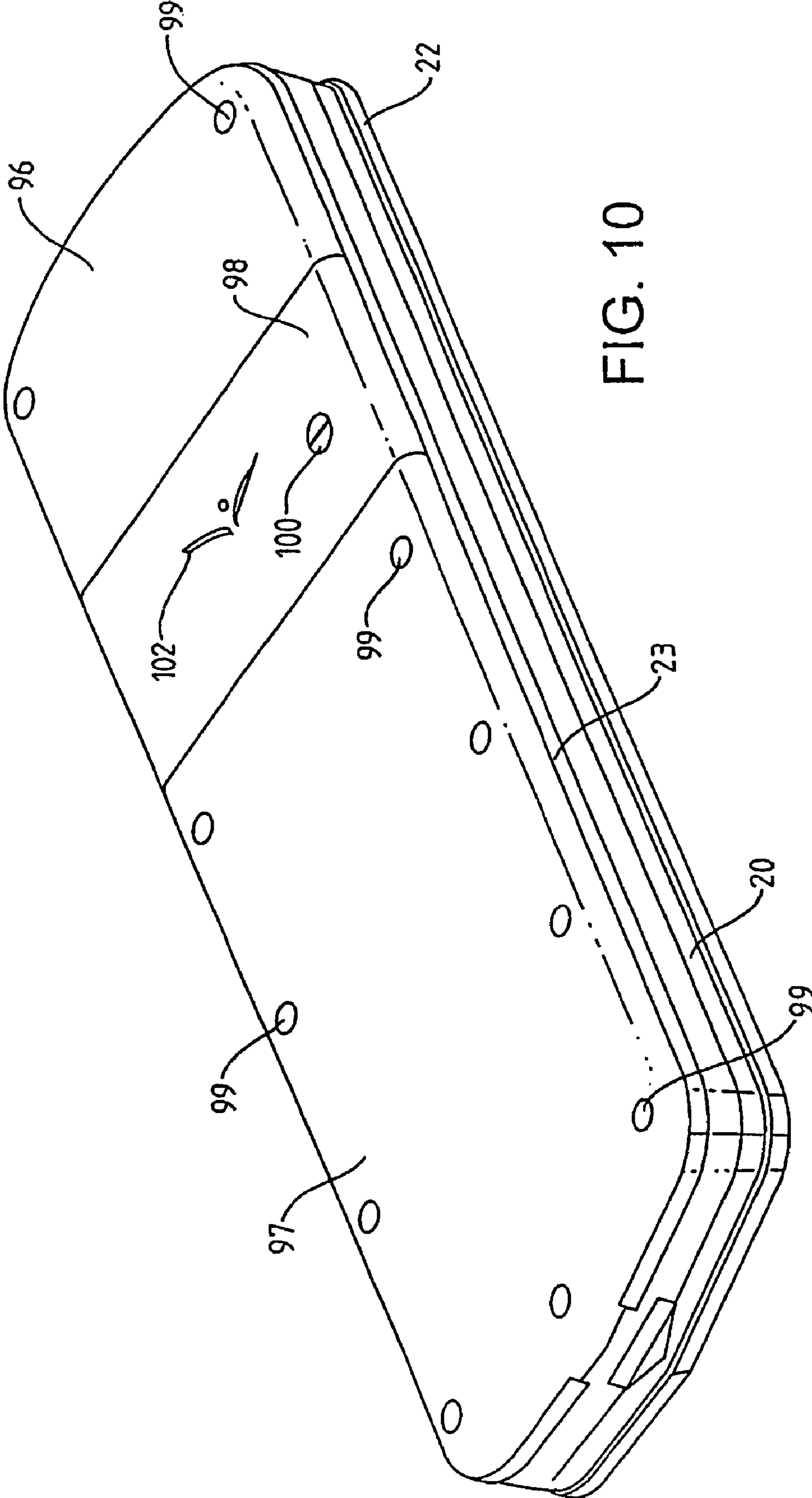

FIG. 10

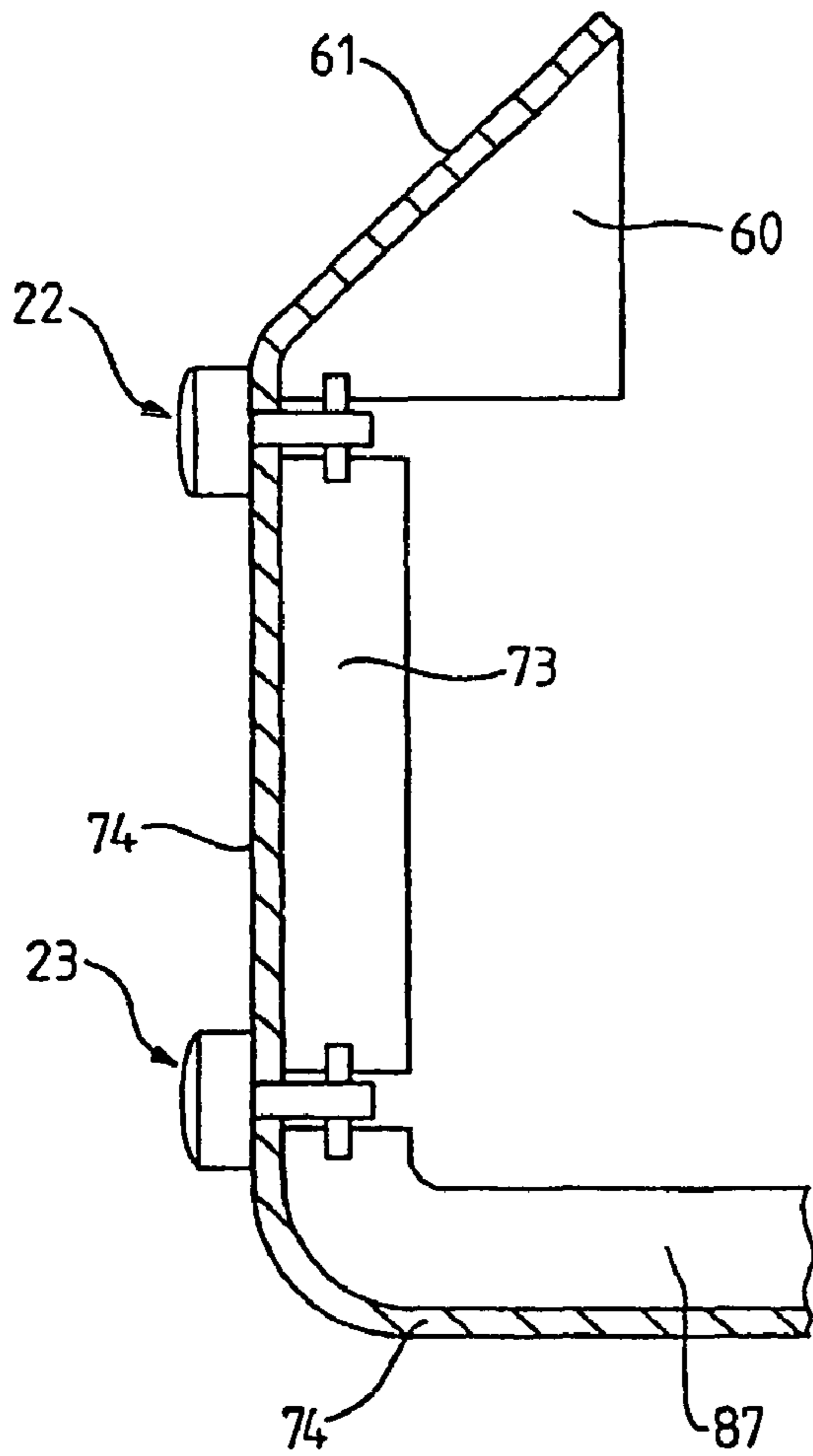

FIG. 11a

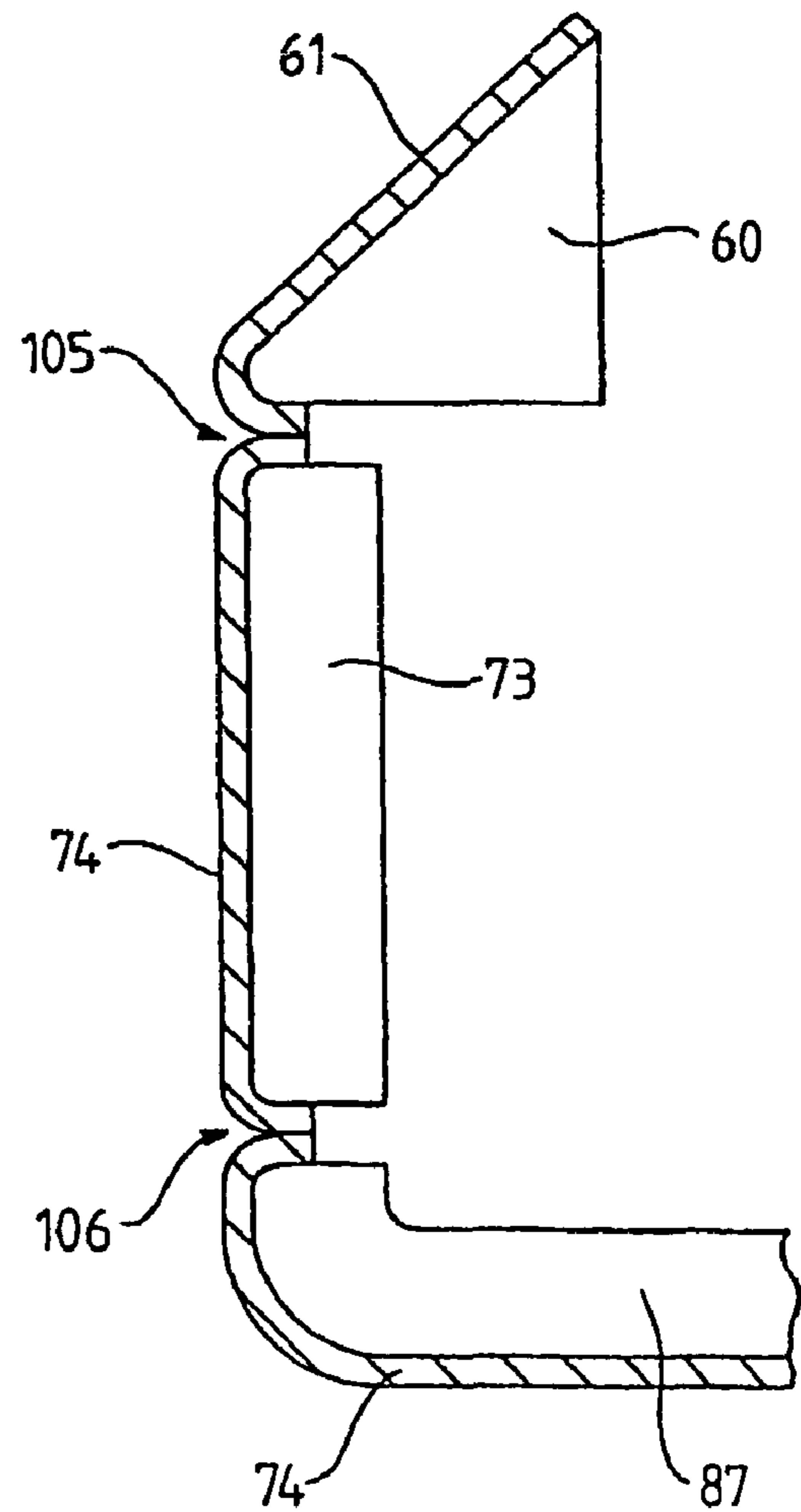

FIG. 11b

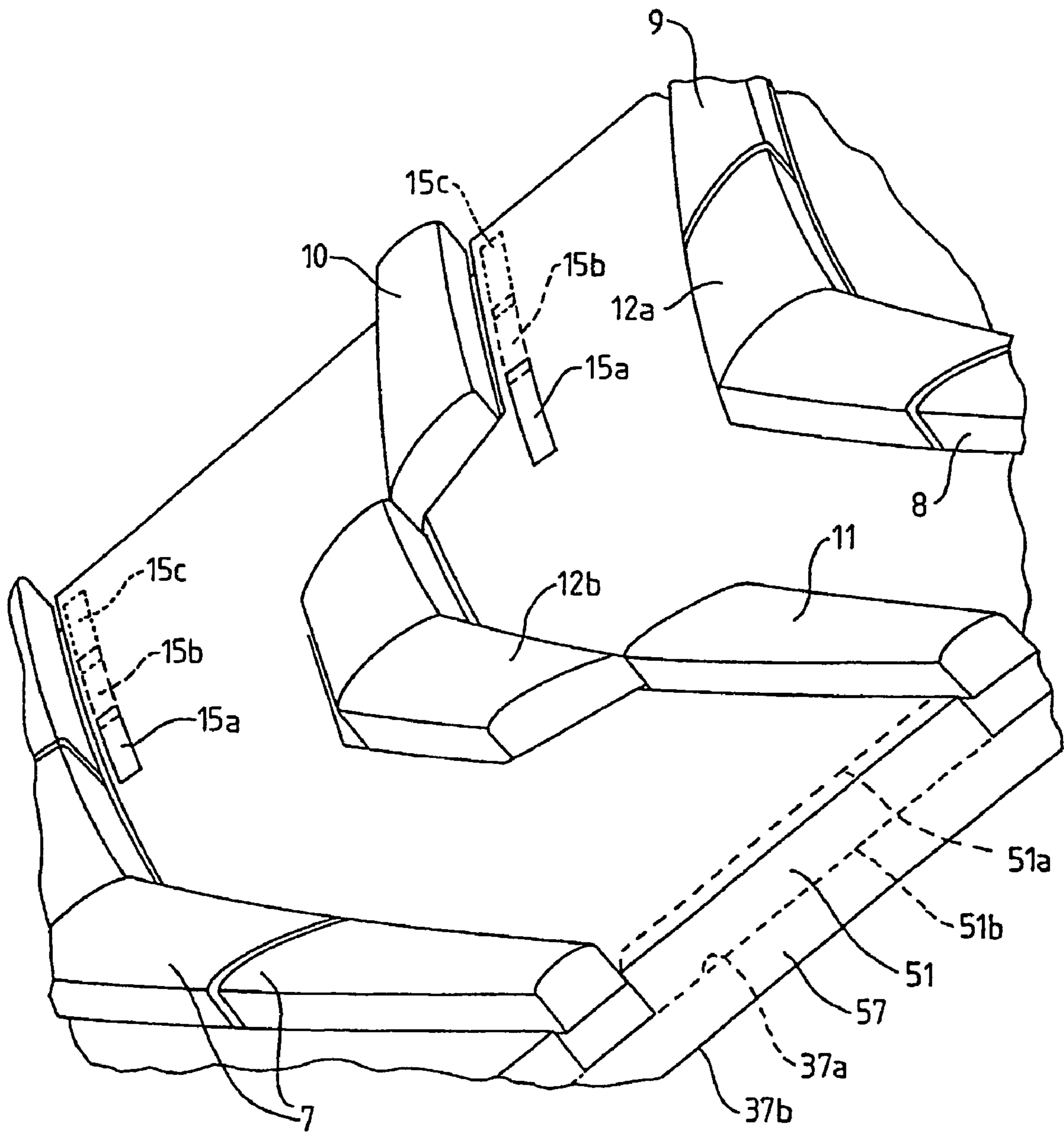

FIG. 12

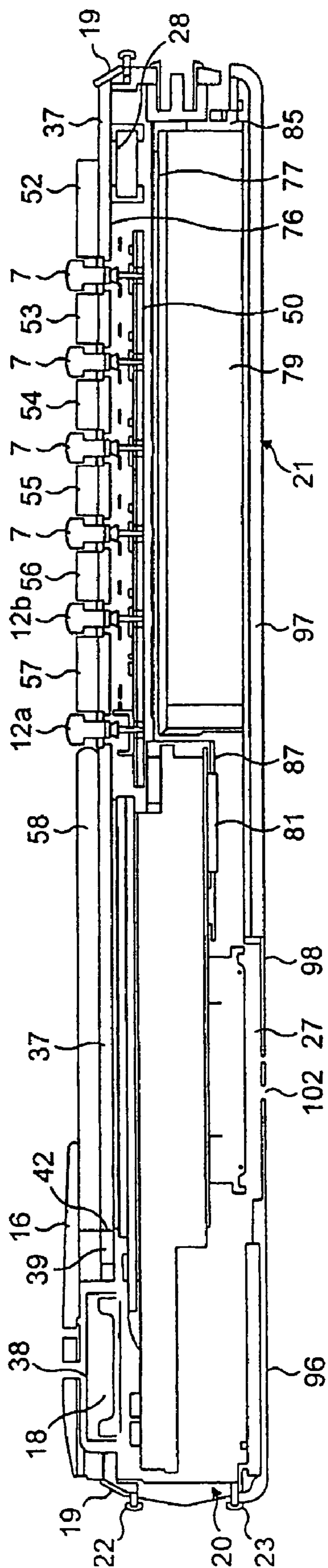

FIG. 13

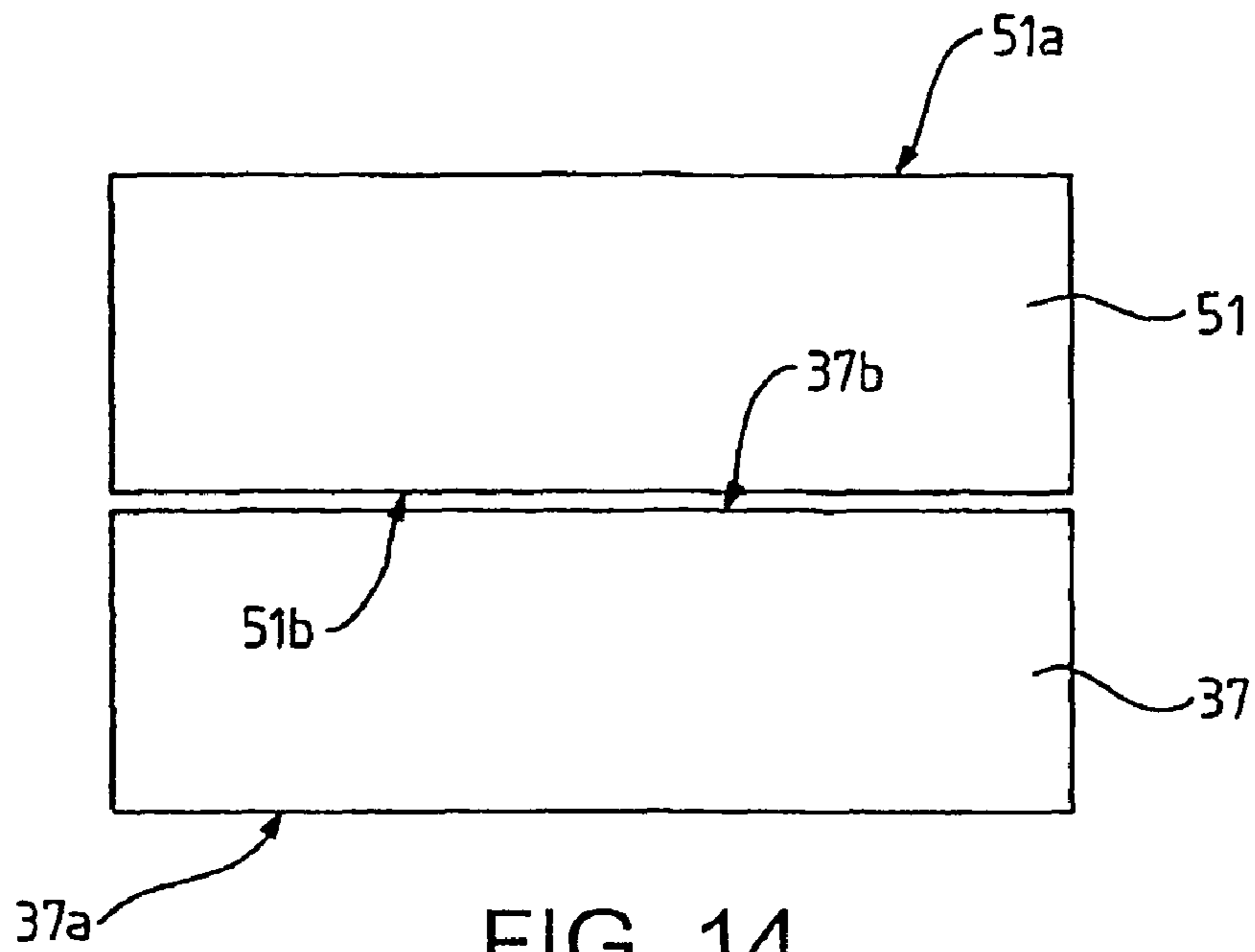

FIG. 14

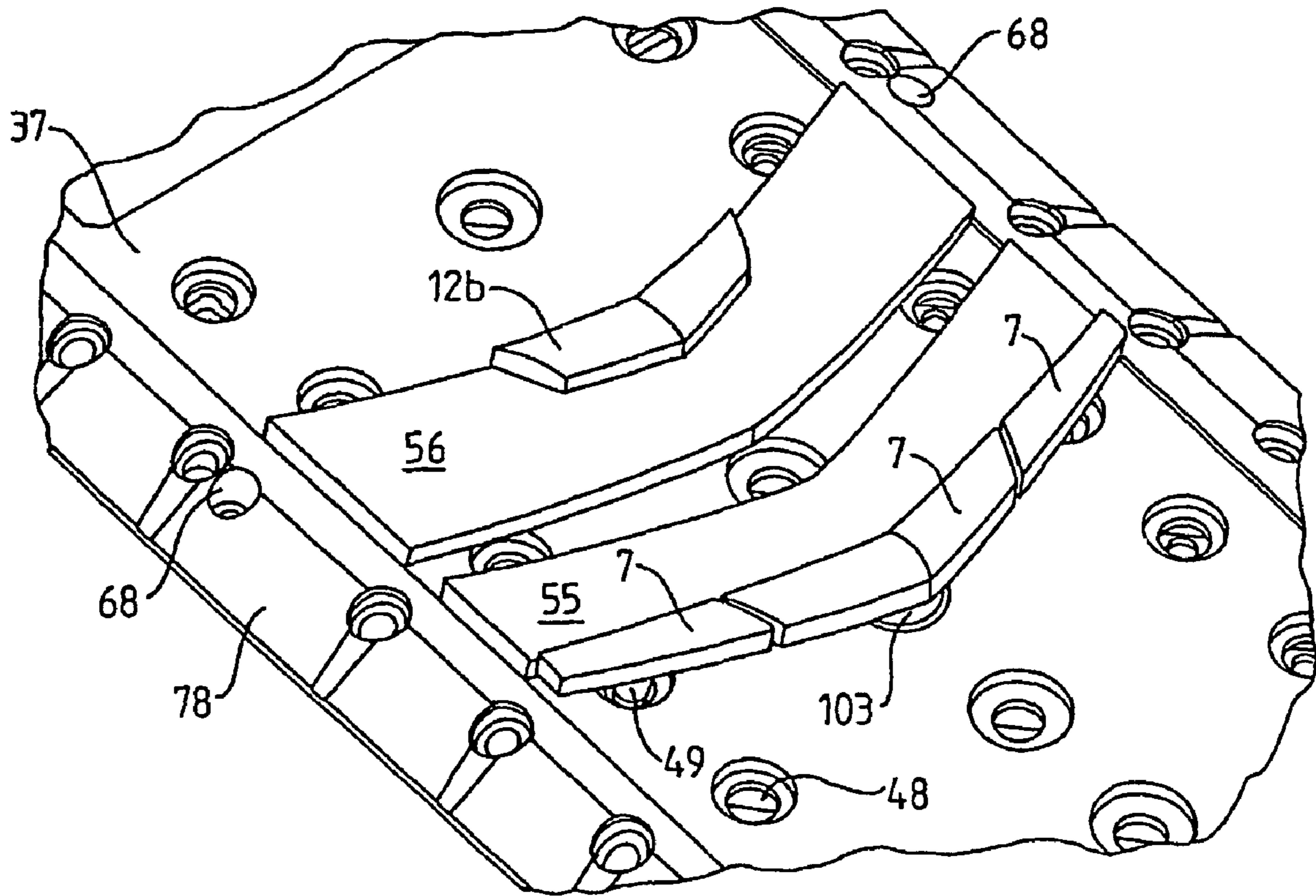

FIG. 15

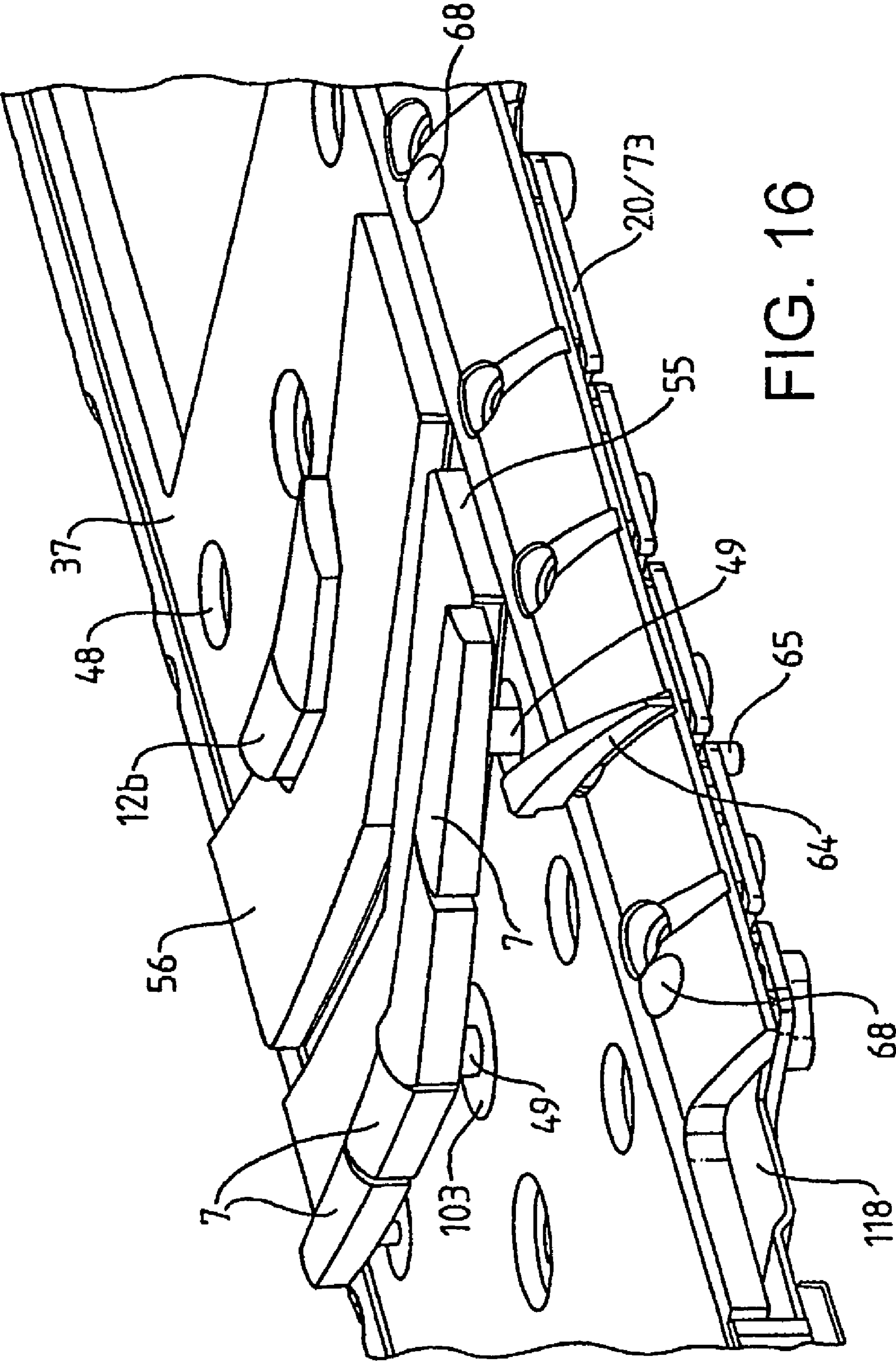
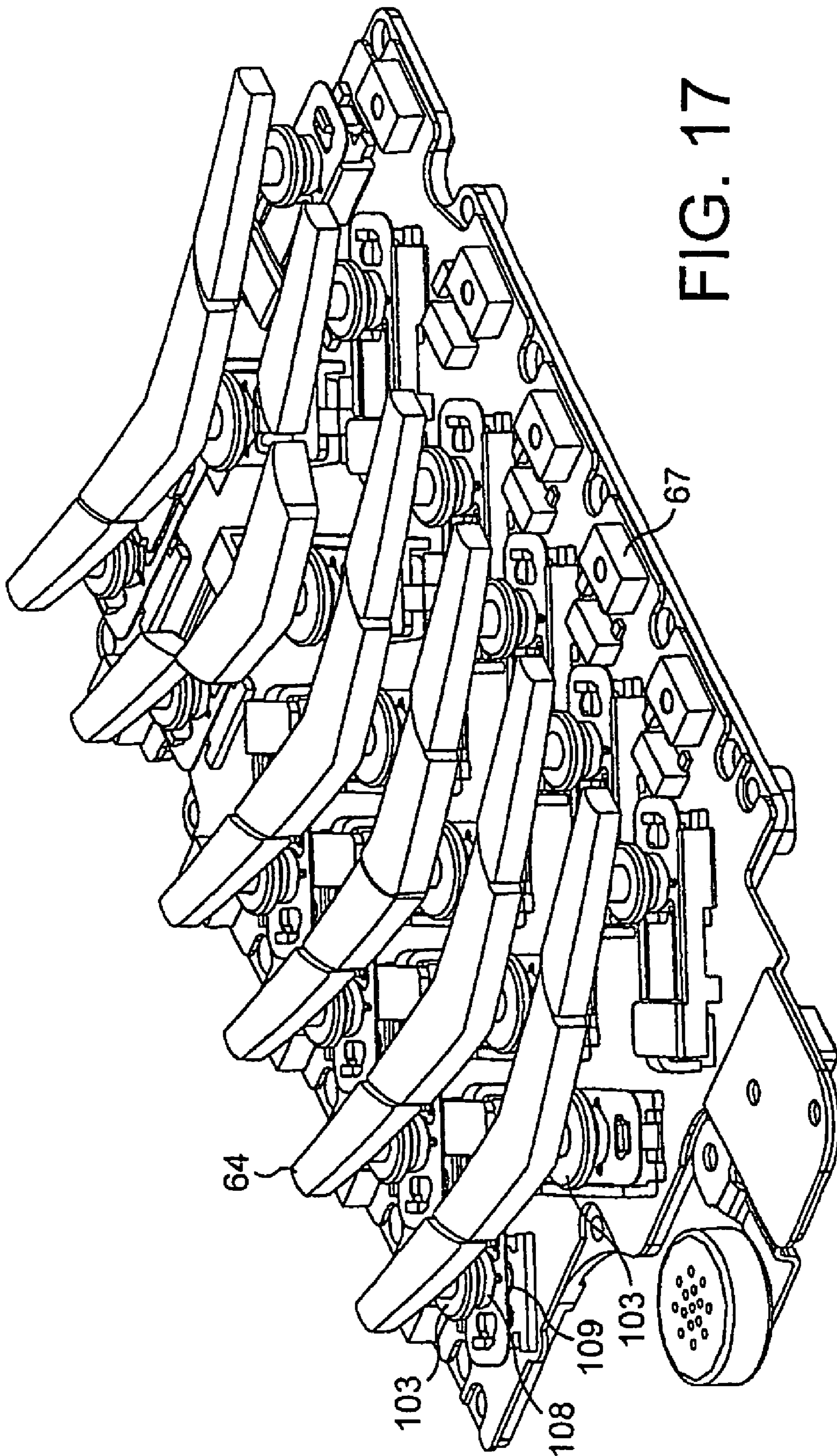

FIG. 16



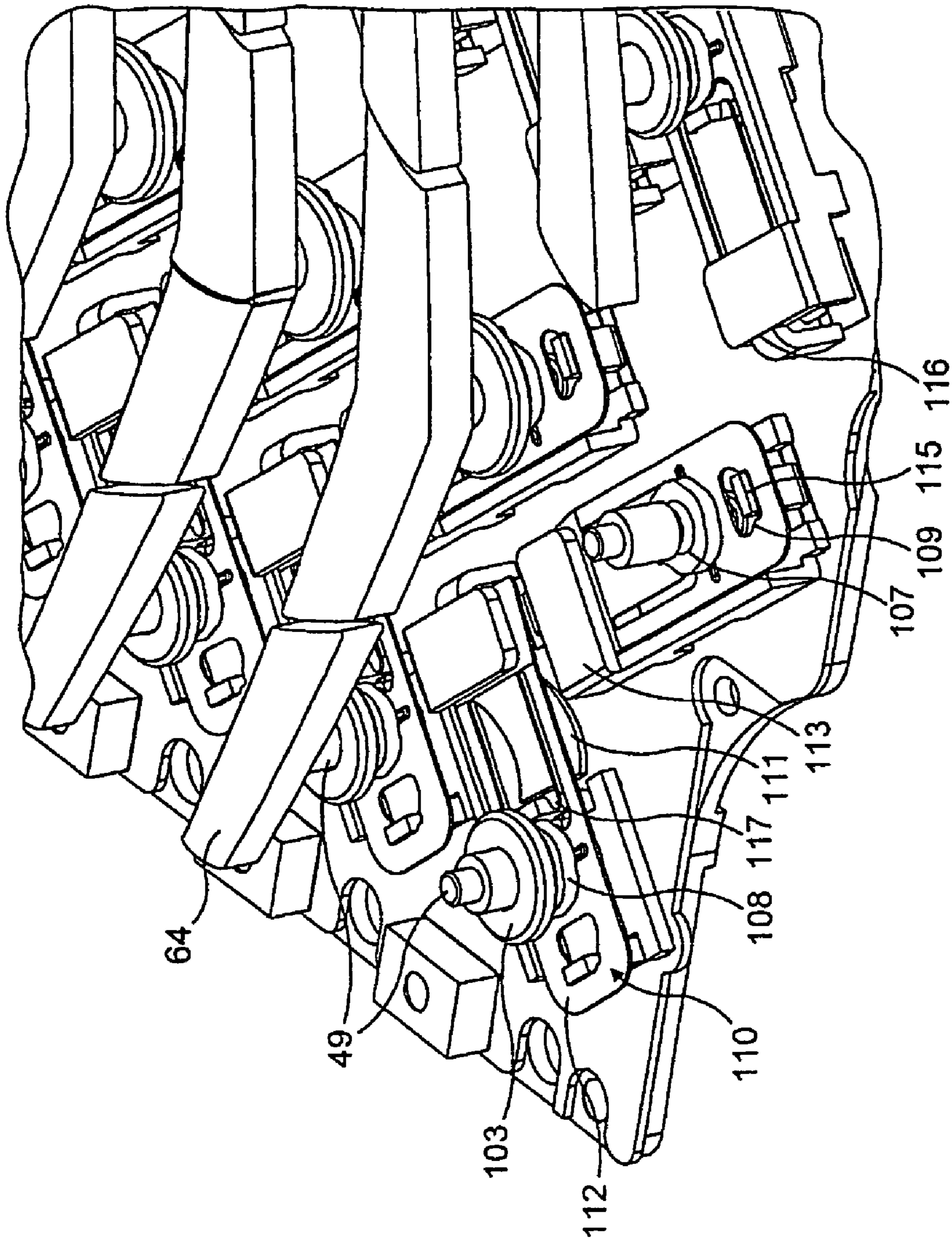

FIG. 18

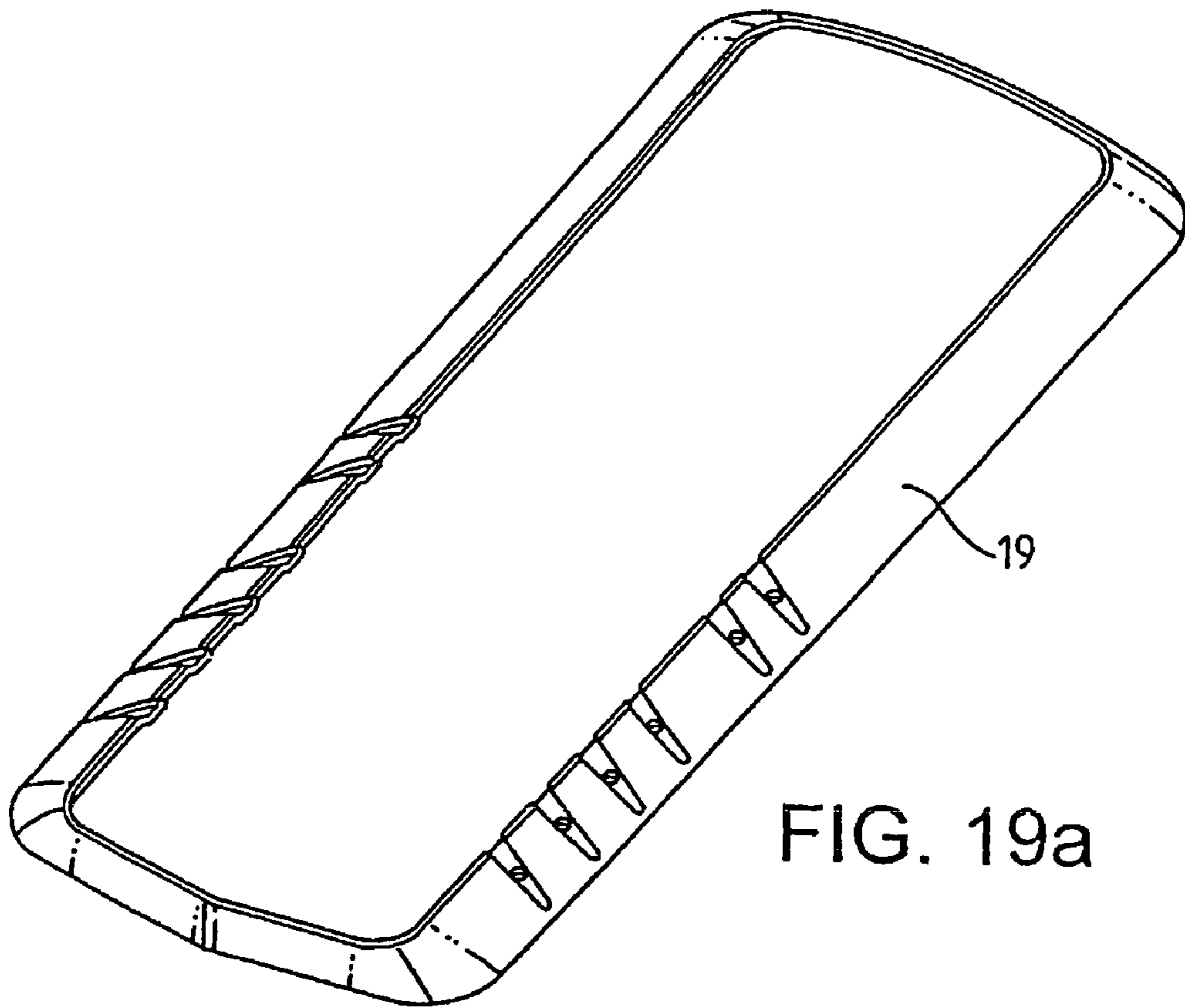

FIG. 19a

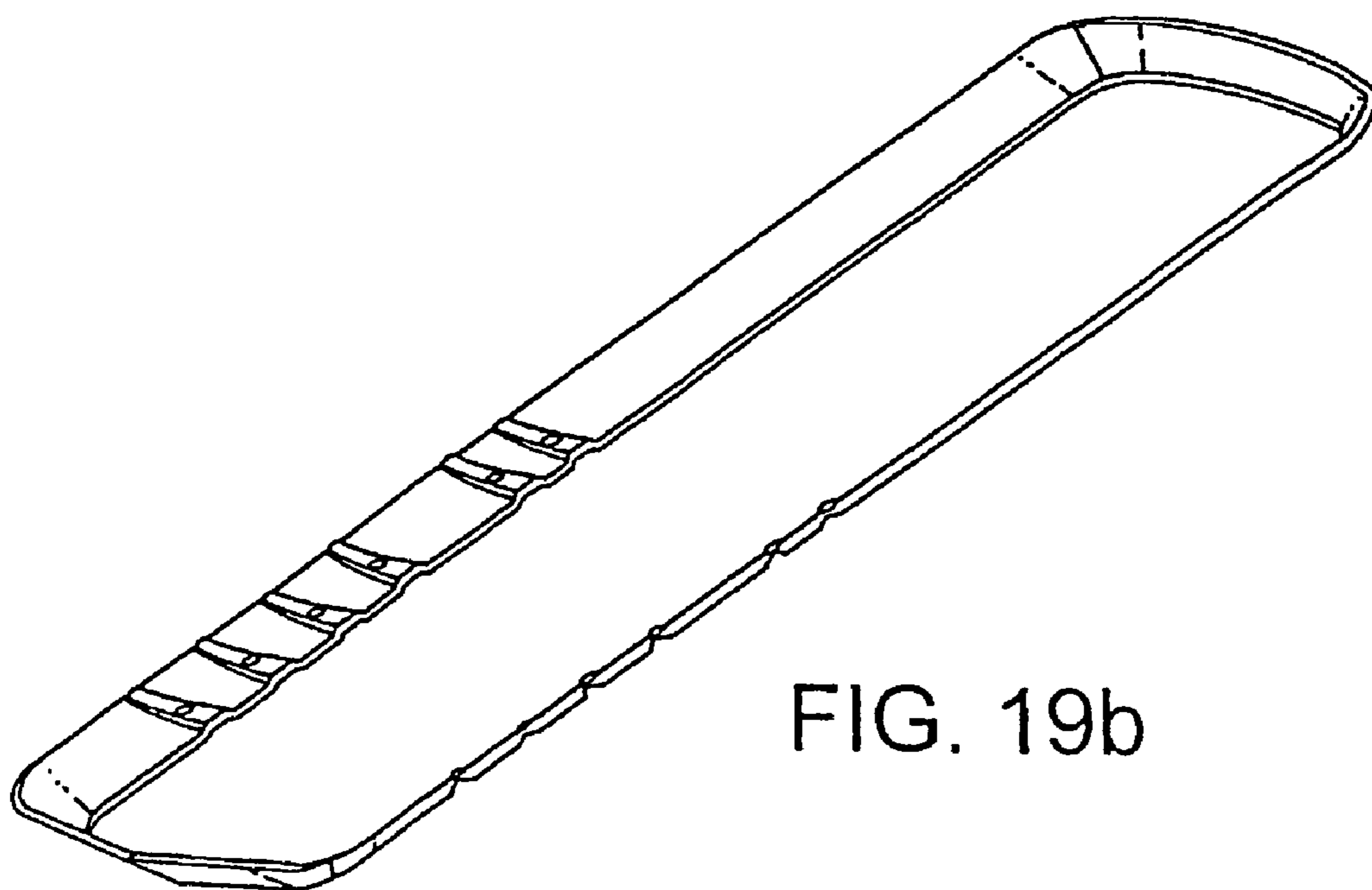

FIG. 19b

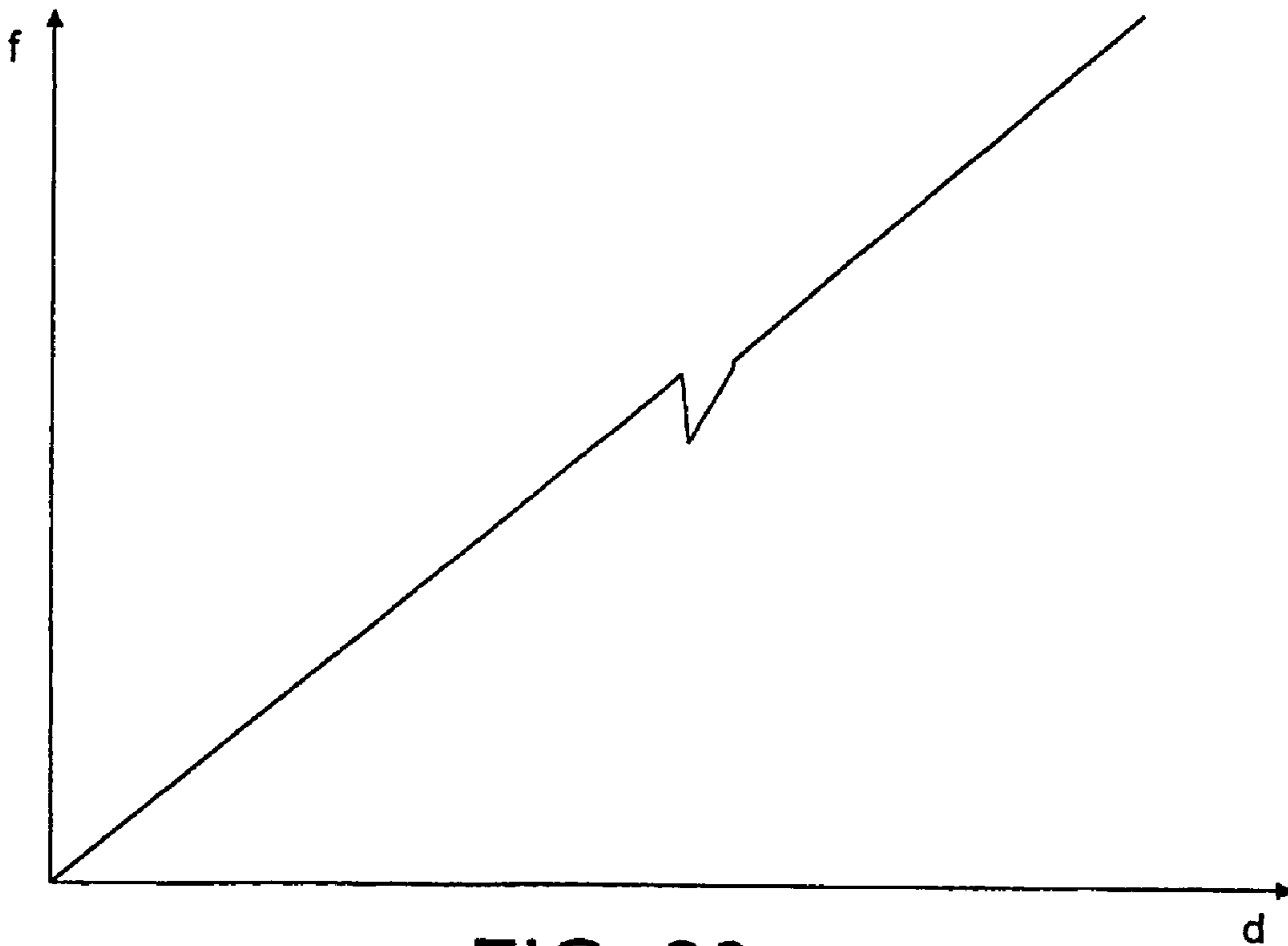

FIG. 20a

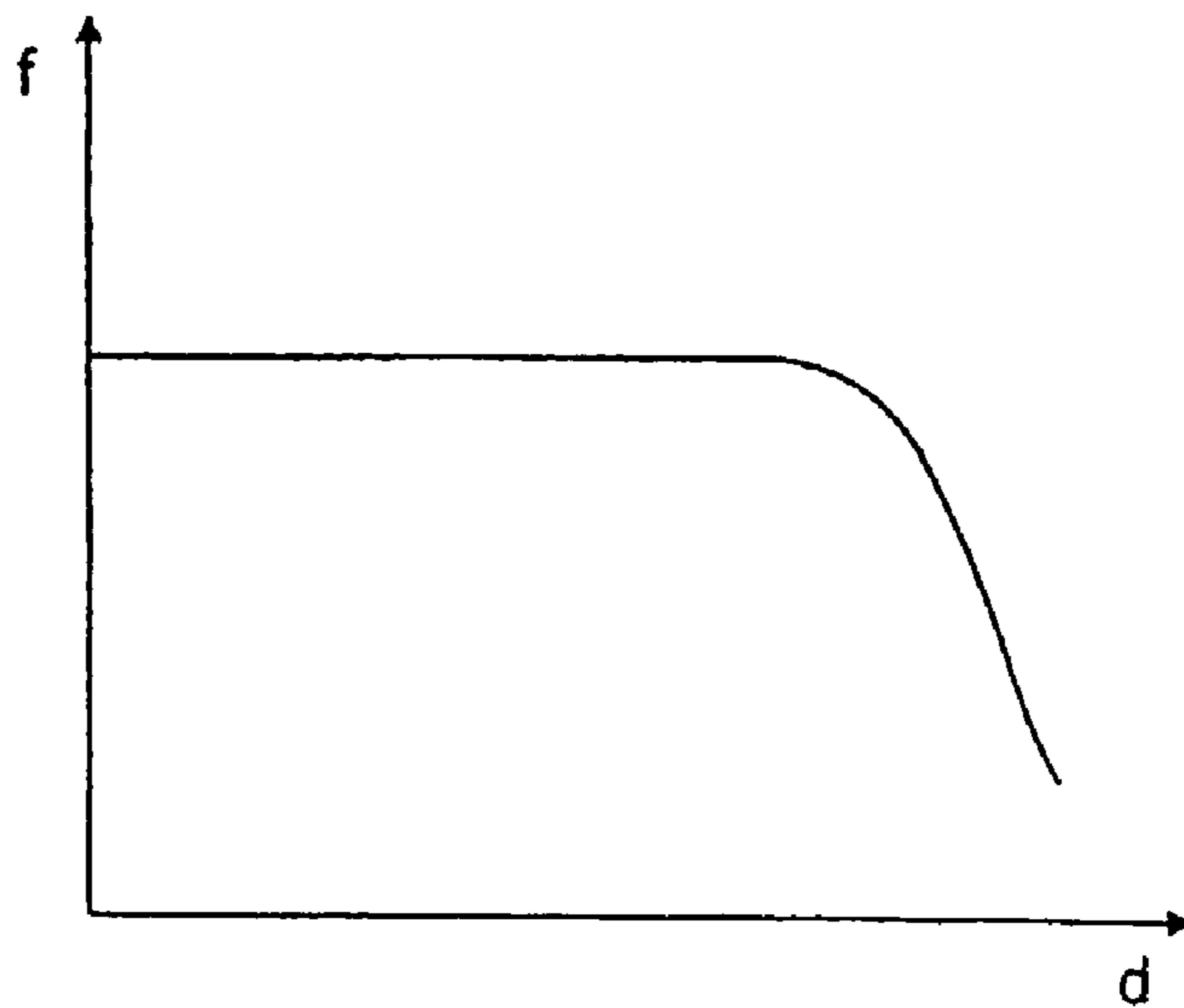

FIG. 20b

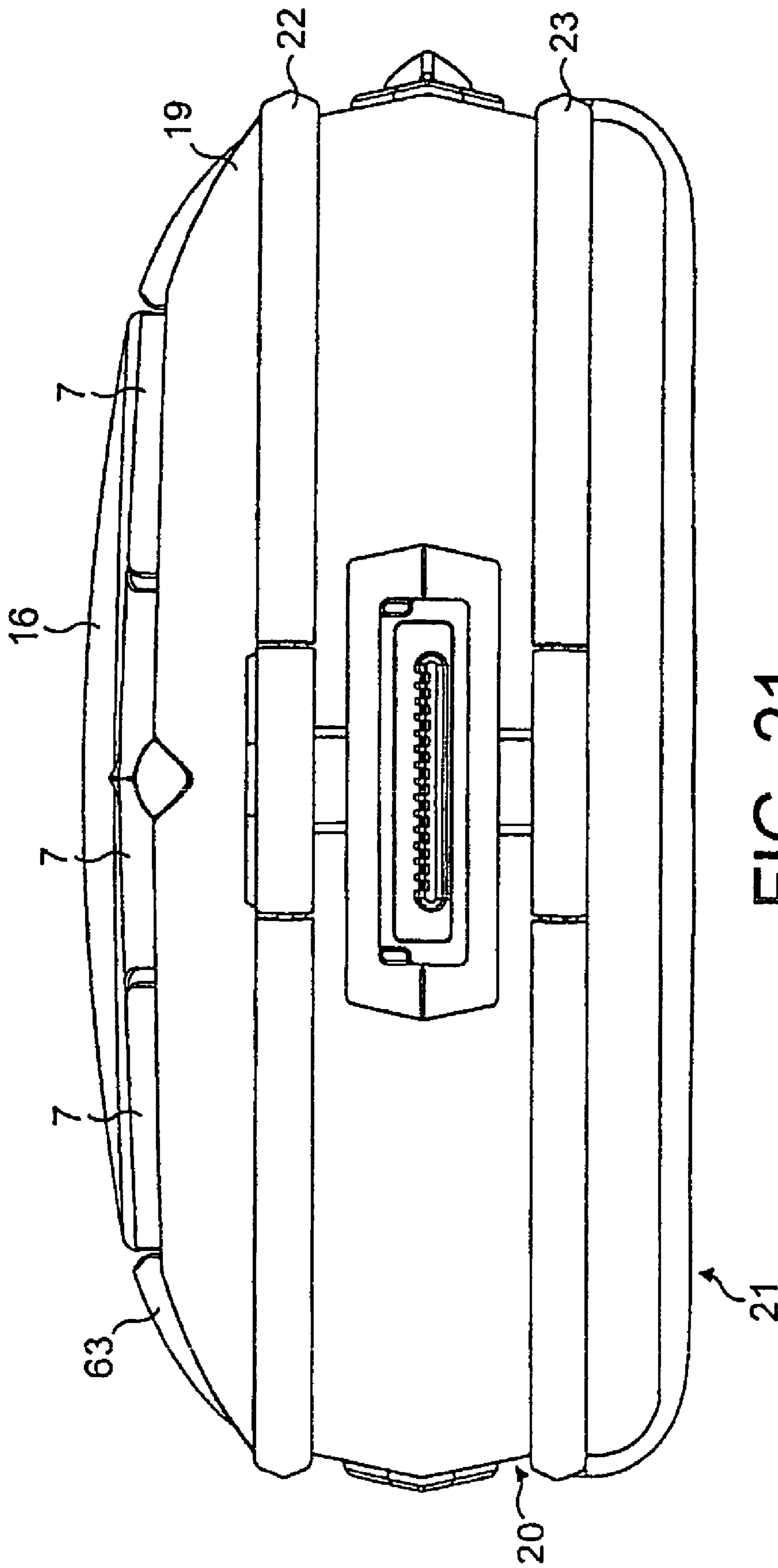

FIG. 21

1**CASING**

FIELD OF THE INVENTION

The invention relates to portable communication devices and in particular to the materials used in casings for such devices.

BACKGROUND OF THE INVENTION

Items of technical equipment are generally bought for their functionality. They are quickly superseded and replaced when a faster, cheaper to operate, smaller, or higher specification alternative is released onto the market, the previous model being discarded. The value of the product to its user is in what it can achieve, and perhaps to an extent the image that attaches to the ownership of such an item. As fashion is constantly changing so is the image promoted by owning an individual item, particularly in a fast moving technical area. What may have been the height of fashion can swiftly become out moded.

In fast moving technical areas changes are prompted by, amongst other things, the requirement to make the product smaller, cheaper to manufacture, cheaper to operate, have greater functionality, make use of emerging technologies or move with the latest tastes in design.

Generally when a radically new technical product is brought onto the market, for an initial period the product is relatively elite and expensive. Consequently only limited numbers are produced. In the early years, because of the inherent rarity and the likely high cost of components, there is a propensity to repair as much as possible. Despite the economic requirement for repair, as soon as a more desirable product is launched, the previous item is soon obsolete and abandoned. The drive for innovation is the challenge of technical advancement and reduction of costs. This pattern has been followed with many items including the first colour televisions, the first video recorders, and the first mobile phones.

In other products such as personal computers upgrading is a possibility, but these upgrades are possible only within carefully predefined limits. The casings are retained as a matter of convenience, it being the retention of the maximum amount of the existing technological hardware that drives the changes. The casing itself will be replaced when the predefined limits for upgrading the product are exceeded.

SUMMARY OF THE INVENTION

In accordance with the present invention there is provided a precious casing for a personal communication device defining an internal space for accommodating an engine and including an operating face carrying a user interface having a plurality of user input elements, the casing comprising, a plurality of casing elements capable of individual formation each formed from precious material.

The present invention provides a radically different approach to such products. When considering a precious, customisable and updateable, highly technical product with sentimental value, the drives for previous innovation are turned on their heads. New problems are created that have never been contemplated and need to be solved. The present invention addresses some of these issues.

The user interface can be user for user operation of and data entry to the communication device. The casing may also be compatible with an interactive display responsive to user input via the input elements.

2

Devices such as mobile phones and computers are designed with the foreknowledge that within periods as short as months, more desirable products with vastly greater functionality will have overtaken the current models.

The present invention provides a radically different approach to personal communication devices. The casing is created from a number of individual elements made from precious materials to create a potentially unique personalised item.

With this degree of interest being taken in the casing, the engine and its functionality, although important may even become secondary. An electronic engine can be readily superseded, whereas a precious casing, especially one that has high monetary and/or sentimental value cannot so easily be replaced. Casings in accordance with embodiments of the invention may be reusable to accommodate new hardware in engines providing additional processing capability to add to the functionality or performance of the device. This may result in there being some intentional redundancy in the external interfaces of the device to accommodate future, as yet unrealisable, possibilities.

The casing may be a conventional one-part casing or a clamshell, or other two or more part arrangement, where the user input elements or keys may be located on a different face to a display. In such two part arrangements generally respective casing portions are fixed such that one is movable relative to the other. The movement may be rotational or lateral.

A vast range of precious materials is available for the individually formable elements of the device. There are virtually no bounds. Embodiments of the invention use precious and semi precious materials including gem stones, other jewels and minerals, metals including those ranging from gold, silver, and platinum through to alloys such as steel. Materials such as ceramics in their various forms are also available for use in embodiments of the invention, the brittle nature of these materials, being able to be accommodated by the design of some embodiments. In addition, materials not generally considered in the context of technological devices, such as skins, leather being a particular example, and wood and similar materials can also be utilised in embodiments of the invention.

Elements of the structure of an element may be formed from precious material. Instead, or in addition, the individual elements can include precious materials in the form of a surface decoration such as a veneer. The elements could have instead, or in addition, surface texture provided by a particular finish or an engraving or encrustation with gems or other stones or materials.

BRIEF DESCRIPTION OF THE DRAWINGS

Embodiments of the invention will now be described in more detail with reference to FIGS. 1 to 21 of the accompanying drawings of which:

FIG. 1 is a perspective view of a communication device showing one embodiment of the invention;

FIG. 2 shows front, rear, sides and top views of the communication device of FIG. 1;

FIG. 3 is a schematic representation of a communication device suitable for embodiments of the present invention;

FIG. 4 is an exploded view of the face of a communication device of one embodiment of the invention without keys;

FIG. 5 is a view of one layer of a light guide;

FIGS. 6a and 6b are sections through the communication device of FIG. 1 in the display region;

FIG. 7 is a perspective view of a side frame element and located rails for constructing a casing

3

FIG. 8 is a perspective view of the rear of the device with the battery cover removed;

FIGS. 9a and 9b are sections through the communication device of FIG. 1 in the battery region;

FIG. 10 is a perspective view of the rear of the device with the battery cover in place;

FIGS. 11a and 11b are sections showing other embodiments of the invention;

FIG. 12 is a perspective view of part of the input region of the device illustrating the location of legends associated with keys;

FIG. 13 a longitudinal section through the communication device;

FIG. 14 is a schematic section through the light guide illustrating the surfaces available for carrying the legends;

FIGS. 15 and 16 are perspective views of a partially constructed input region of the device;

FIG. 17 is a perspective view of keys of the device including their actuation mechanisms;

FIG. 18 illustrates some of the keys illustrated in FIG. 17, with the key tips removed;

FIGS. 19a and 19b are front and rear perspective views of the outer shell of a bezel respectively;

FIGS. 20a and 20b are a graph showing force against distance for a key such as that illustrated in FIGS. 17 and 18, and a conventional key using a dome respectively; and

FIG. 21 is a bottom plan view of the device of FIG. 1 (with the chin face protector omitted).

DETAILED DESCRIPTION

Embodiments of the invention will be described in greater detail below with exemplary materials being given for some specific or individual elements of the device. Where a material or veneer is discussed in relation to an element, the particular character of the element described is one of many or several that may be provided as options to a party commissioning a personalised device in accordance with the invention. In addition the exact material or surface decoration of an element can be changed.

The embodiment illustrated in FIG. 1 is a handheld communication device 1 with a precious retainable casing 2. The casing 2 of the device has been designed to be customisable to individual taste with precious materials. To enable individual devices to be created, the number of external parts that the casing is formed from is relatively large in contrast to existing communication devices.

The casing 2 has an optically permeable front face 3 providing a seamless transition from a display region 4 to an input region 5 that includes a key array 6. The key array 6 includes a first group of alphanumeric keys 7, for entering telephone numbers, writing text messages (SMS), writing names (associated with phone numbers), etc. Each of the twelve alphanumeric keys 7 is provided with a figure "0-9" or a sign "#" or "*", respectively. In an alpha mode each key is associated with a number of letters and special signs used in text editing. The key array 6 additionally comprises two soft keys 8, 9, two call handling keys 10, 11, two scroll keys 12, and an on/off key 13.

The functionality of the soft keys 8, 9 may depend on the state of the communication device and position within the menu accessed using the scroll keys 12. The current functionality of the soft keys 8, 9 can be shown in separate fields in the display region 4 just above the respective keys 8, 9.

The two call handling keys 10, 11 are used for establishing a call or a conference call, terminating a call or rejecting an incoming call.

4

The two direction keys or scroll keys 12, in the handset illustrated are placed centrally on the front surface of the communication device between the display region 4 and the group of alphanumeric keys 7 perform a scrolling function.

The seamless face 3 is formed from an optically seamless light guide 14 providing light to illuminate the display region 4 and key legends 15 located on the light guide 14 and associated with individual keys of the key array 6.

The front face 3 is overlaid with a pillow 16 providing apertures 17 to channel sound from a loud speaker 18 and providing an appropriate feel for an element of the device that will be located close to the user's ear. The front face 3 is surrounded by a bezel 19 that can be made from a precious metal. This acts to protect the edges of the light guide 14 and can help in some embodiments in securing the elements of the casing 2 together.

The keys of the key array in this particular embodiment are arranged to provide particular sensory guidance to the user. Aspects of the design also allow the light guide 14 to be made from a wide range of materials including those that are brittle and so need to be carefully handled and protected from shattering.

The casing 2 is formed from the front face 3 surrounded by the bezel 19, a side frame 20 and a back cover 21. The interface between the side frame 20 and the bezel 19 and the side frame 20 and the rear cover 21 are shielded by rails 22, 23 in this embodiment. The rails 22, 23 hide raw edges from view and exposure to ensure that the device 1 is both long lasting and elegant. The construction of the casing 2 enables the casing 2 to be opened with ease to update the engine 24 inside when desired. The casing 2 is also designed to allow the device to accommodate different sized and shaped engines 24, which may be necessary through its life.

Other elements of the design will be discussed in greater detail with reference to the later drawings. By way of introduction, the device will be briefly discussed with reference to its functional elements.

The communication device 1, includes the key array 6, a display 25, an antenna 26, an ear piece speaker 18, a polyphonic speaker 27, and a microphone 28. The communication device 1 is adapted for communication via a wireless telecommunication network, e.g. a wireless network. However, the communication device could also have been designed for a cordless network. FIG. 3 shows schematically and functionally elements of the communication device 1. The microphone 28 records the user's speech, and the analogue signals formed thereby are A/D converted by an A/D converter before the speech is encoded in an audio part 29. The encoded speech signal is transferred to processor 30. The processor 30 may support software in the phone. The processor 30 also forms the interface to peripheral units of the apparatus. These may include a Random Access Memory (RAM) 31 and a Flash Read Only Memory (ROM) 32, a SIM card 33, the display 25, and the key array 6, and perhaps a browser application 34, and a location module 35.

The browser application 34 can be used to request and receive information from the Internet. The location module 35 enables the terminal 1 to determine its current position.

The processor 30 communicates with a transceiver 36, e.g. a circuit, which is adapted to send and receive messages in a telecommunication network. The telecommunications network may be a GSM or W-CDMA network, but the invention may also be applied in connection with any other network, including but not limited to other kinds of wireless networks and various forms of cordless phone systems or in dual band phones accessing sets of these systems or networks. The

5

audio part **29** speech-decodes the signal, which is transferred from the processor **30** to the earpiece **18** via a D/A converter.

As discussed above, the front face **3** is optically permeable and acts as a light guide. The seamless light guide, passing light over the display region **4** as well as providing light to illuminate the key legends **15** reduces the number of lighting elements required to illuminate the device and provides a seamless transition from one area of the front of the device to another. By using this technique for delivering light and also allowing the light guide **14** to form the front surface of the device **1** as in the embodiment disclosed, the device is visually striking, there being no visible transition from the display region **4** to the input region **5** where the key array **6** is located.

The embodiment illustrated in FIG. **1** has a light permeable front face **3** that can be formed from sapphire or a similar precious stone. As soon as a mineral such as sapphire is used in place of other more flexible light permeable materials such as plastics, additional problems are introduced associated with the character of the material. In designing a durable device having, for example, a brittle material for a front piece **3** there are many difficulties. In one manifestation of the embodiment illustrated in FIGS. **1**, **2** and **4** to **6**, the light guide **14** is an optically seamless composite layer. As can be seen most clearly in FIG. **4**, a plastics layer **37** that may be formed from Perspex or other transparent and/or translucent materials runs the entire length of the front face **3**. There is a cut-out **38** for accommodating the ear piece speaker **18** that is optimised for use close to the ear. There is another cut-out accommodating a light pipe diffuser **39**. This is located under the pillow **16** and extends across the width of the device **1**. By placing the light pipe **39** under the pillow **16**, a bright area on the front face is avoided and the light visible in the light guide will be diffused. LEDs **40**, **41** are located at each side of the device at each end of the pipe **39**. Light from the LEDs **40**, **41** is channelled through the pipe **39** and diffused. The light pipe **39** in this embodiment, is coated with reflective material so that light is channelled through the surface **42** that runs along the top of the LCD display **25**. Embodiments without the coating provide some of the advantages. The diffused light is accordingly channelled into and along the major axis of the light guide **14** to provide substantially uniform lighting for the LCD **25**.

In this way light is pumped into the light guide **14** along the major axis from above the LCD **25**. The light from the light pipe **39** illuminates the display region **4** and provides lighting for the input region **5**. As illustrated in FIG. **15**, additional LEDs **43** or other lighting elements are positioned along the edges of the Perspex layer or sheet **37** in the input region **5** to further illuminate the legends **15** for the keys of the array **6**. The surface of extending portions **78** of the Perspex layer or sheet **37** is shaped to channel light from adjacent top firing LEDs **43** or the like towards the upper surface of the main portion of the layer or sheet **37**. This assists in providing substantially uniform lighting for the input region. The additional LEDs **43** or the like are shielded from view by the bezel **19** to avoid light spots being visible and encouraging a uniform diffuse light across the light guide.

The LCD **25** itself is bonded to the rear surface of the Perspex sheet **37** with an energy absorbing adhesive sheet **45**. Using this technique and ensuring that there are no air gaps between the front of the LCD **25** and the Perspex sheet **37**, provides a robust solution for mounting the LCD **25**. The surface of the LCD **25** that is delicate and generally needs a protective layer distanced from it is protected by the Perspex layer **37** adhered to one of its faces. The drivers **44** for the LCD **25** can be seen in FIG. **5**.

6

In the embodiment illustrated the Perspex layer **37** includes apertures **48** for locating individual keys and allowing the key shafts **49** to travel to make contact with a printed circuit board **50** located within the casing **2** to register user input. An independently inventive key layout, suitable for use with the general concept discussed, will be described in greater detail below.

As can be seen most clearly from FIG. **4**, the second layer of the composite light guide **51** is made in a number of sections **52-58**. This is to allow for the choice of brittle materials to be used for the second layer **51**. Sapphire has properties including its scratch resistance and optical clarity that make it suitable for use in this context although the material of this element is selectable a ceramic material could be utilised in this arrangement. Other suitable materials are glass and other minerals and precious and semi precious stones. When a transparent material such as sapphire is used, however, the light guide provides an external surface to the device. Arrangements for the second layer similar to those disclosed in concept in the illustrated embodiment are not necessary when the materials are not brittle. Alternative arrangements will, however, be apparent to the skilled man for accommodating brittle materials in this context.

As mentioned above sapphire is brittle. When considering how to introduce such a material into a casing **2** that is to be long lasting and durable, problems arise. This is particularly the case when the device **1** will inevitably be subjected to knocks and is likely to be dropped many times in its long existence. All brittle parts are bonded to a carrier formed from e.g. plastic or titanium in order to better absorb shock. In the embodiment described, the sapphire is formed in individual sections **52-58** for ease of manufacture. Each of the pieces is adhered to the Perspex layer **37** using a UV curing adhesive based on hybrid acrylic technology. In order to increase the durability of the composite light guide **14** and strengthen it against damage, the sections **52-58** are adhered to a more flexible Perspex layer **37** leaving gaps **59** extending across the entire width. These gaps **59** act as hinges to allow the composite layer **14** to be relatively flexible along its major axis. In the embodiment illustrated, the layout of the key array **6** has been designed with this in mind. The alpha numeric keys **7** are arranged in groups of three extending across the whole width of the second layer of the composite **51**. The function keys or soft key **8**, **9** are also arranged in two groups of three. The soft keys **8**, **9** and the top scroll key **12a** follows the line of the alpha numeric keys **7**. The call handling keys **10**, **11** and the bottom scroll key **12b**, which is displaced from the line of the others, defines the lower edge of one of the elements **57** and the upper edge of another of the elements **56**. This makes the second row of keys **10**, **11**, **12b** distinctive whilst still avoiding problems in manufacture of the elements **52-58**. The specific key array **6** illustrated has other properties and advantages that will be discussed later.

Although the embodiment described is designed with a brittle material such as sapphire in mind, the resultant arrangement could be formed from any number of other materials including plastics that provide the required optical characteristics. Similarly different key arrangements could be used without departing from individually inventive concepts that are disclosed.

When using a brittle material for a front face light guide **14** problems are also encountered when connecting the front face **3** to the rest of the casing elements. In the illustrated embodiment the edges of the brittle elements **52-58** are protected by the bezel **19** that sits around the whole of the face. The bezel **19**, in this embodiment, is formed from a bezel support **60** overlaid with a 0.5 mm thick metal sheet, the bezel

cover **61**. The metal sheet **61** is bonded to the bezel support **60**, that may be formed from plastic, with an adhesive such as a two part epoxy adhesive or a two part acrylic adhesive. As the metal sheet **61** is relatively thin this keeps the weight of the casing **2** down and also allows relatively precious metals such as titanium or gold to be used at relatively lower cost. The bezel **19** could, however, be a single part and/or be formed from a single material for example titanium.

The transparent face **3** in this particular embodiment is securely held in place by a robust mechanism. The Perspex layer **37** to which the elements **52-58** are bonded extends beyond the area covered by the elements to provide a lip or edge **62** around the whole of the composite light guide **14**. This edge **62** is used to secure the front face **3** in position as it is tucked under the bezel **19** that defines the perimeter of the front face and squeezed between the bezel **19** and the side frame **20**.

As can be seen in FIG. 1, the bezel **19** is punctuated with front face protectors **63** whose function will be described in more detail later. These front face protectors **63**, in this particular embodiment play a role in holding the casing elements together.

The front face protectors **63** have a tip part **64** that extends over the bezel **19** and a shaft **65** that passes through the bezel **19** and into the plastic side frame **20**. The shaft **65** may be tightened onto the frame **20** using a nut **95**. In this case the nut stops the front face protectors from falling out of the device. In one embodiment the shafts **65** are screwed into the tips **64** at one end and into the side frame element **20** at the other although other manners of connection could be employed. The shaft **65** and tip **64** could also be one piece rather than two. The bezel **19** and the Perspex layer **37** of the transparent face **2** are captured by the front face protector **63** and side frame element **20** as can be seen in FIG. 9b. The front face protectors **63** accordingly grip the transparent face **3** securely between the side frame **20** and the bezel **19**. The front face protectors **63** are only located next to the key array **6**. In order to secure the transparent face **3** around its perimeter additional screws **66** are added to draw the bezel **19** towards the side frame **20** and squeeze the transparent face **3** in place. In one embodiment, the screws **66** thread through the side frame **20** and tap into the bezel support **60**. Once the bezel support **60** is secured to the side frame **20** the outer shell **61** of the bezel **19** can be adhered to the support **60** to hide the tapped screw ends **66**. Alternatively the bezel **19** is stuck to the support first (a sub-assembly) and this sub-assembly is then screwed to the frame.

As can be seen in the figures, although the more flexible transparent substrate **37** is overlaid by the bezel **19** secured in position by the front face protectors **63** and other connectors, the sapphire is maintained spaced from the bezel **19** so that it is protected from chipping or other damage as a result of contact. The edges of the sapphire elements do not protrude above the edge of the bezel **19** to provide further protection for the more vulnerable edges. In the arrangement described, the transparent face **3** is gripped in position between the bezel **19** and the side frame **20**. The more flexible substrate **37** could, however receive screws or other fasteners to located it relative to the other frame members without damaging the more brittle sapphire layer. The choice of material for the bezel is one open to selection. Precious metals including gold, platinum, silver, steel amongst others would be suitable. The same applies to the material of the front face protectors. Both these elements and others that the skilled man will realise are suitable could be encrusted with precious or semi precious stones such as sapphires, rubies, emeralds and diamonds

amongst others. Other crystals or minerals or other materials and veneers could also be utilised.

To reduce the ingress of dirt or fluids a sealant **69** is located between the bezel **19** and the transparent face **3**. One way in which this can be introduced is to paint a seal on the underside of the bezel **19** which when dry is compressed between the transparent light guide **14** and the bezel **19** when the bezel **19** and the side frame **20** are pulled together.

As can be seen in FIG. 6 or 9, a first rail **22** is located in the interface between the side frame element **20** and the front face **3**. The rail **22** hides the discontinuity between the parts from sight and protects vulnerable edges to enhance the durability of the device **1**. The rail **22** may be a stamped metal piece 'T' shaped in section extending around the perimeter of the side frame **20**. The stem of the 'T' **68** is trapped between the side frame member **20** and the bezel **19** as these two pieces are drawn together on assembly. The stem of the T has apertures **70** that sit over corresponding projections **71** on the side frame **20** member to prevent it from being withdrawn from between the two parts when in position. The top of the T acts as a carrier plate to which an additional extruded piece **72** is soldered or otherwise adhered to provide a seamless finish. The stem could instead be formed from a plastics material.

The side frame member **20** in this particular embodiment is a plastic support **73** with an exterior cover **74**. The cover **74** may again be a metal sheet formed, for example, from a precious metal or perhaps a wood veneer or another layer such as leather or other skin. The bonding agent most suitable for adhering the layer to the plastic frame member **73** will differ depending upon the materials that need to be adhered. For metal to plastic a suitable adhesive is a 2 part epoxy resin or 2 part acrylic adhesive. For metal to metal the adhesive would be a reactive polyurethane film or a two part epoxy resin. Similarly the back cover **21** in this embodiment may have a plastic frame and be covered with for example a leather, wood or perhaps metal veneer. With the flexible veneer materials such as leather, it is preferable for the material to be taut on the frame. This is achieved during the veneering process using conventional techniques.

The transparent face **3** provides a seamless transition between the display **4** and the input regions **5**. In the display region **4**, the LCD **25** is located behind the transparent face **3** and in the input region **5** the key mechanism **75** lies behind it. In one embodiment described, the key mechanism **75** can be seen through the front face **3**. However, in other embodiments the inner surface **76** of the Perspex substrate **37** may be coated with an opaque material to prevent the inside of the device being seen. Alternative methods of obscuring the inner workings of the device from view such as introducing additional opaque layers or obscuring the view in other ways will be apparent to the skilled man.

For embodiments where, for example, the key operating mechanism **75** can be viewed through the front face **3**, it may be desirable to obscure the PCB **50** from view.

The constructed casing **2** provides a housing for the printed circuit board **50** holding the engine components **24**, and a battery **79**. When the device **1** is a radio telephone, a SIM card holder **80** is provided to accommodate a SIM card **81**. For operation under some radio protocols this will clearly not be necessary.

Returning briefly to the front of the device, located above the display region **4** is the pillow **16** so named because it designed for the user to rest his or her ear against when making a telephone call. The pillow **16** overlays the ear piece **18** of the device. As described previously there is a cut-in in the Perspex substrate **37** of the light guide **14** to accommodate the ear piece **18**, the pillow **16**, in the illustrated embodiment

is adhered to the Perspex substrate **37** covering the ear piece **18**. The pillow **16** provides suitable apertures **17** to channel sound to the user. The characteristics of pillow **16** both in terms of the material and surface decoration may be selectable by a commissioning party.

The Perspex and sapphire light guide **14** is relatively cold to the touch, the material of the pillow **16** can be chosen to be a material that is inherently warmer to the touch and less prone to marking than a transparent shiny surface. Materials that are thought to be particularly suitable are ceramics or wood and leather veneers. The shape of the pillow **16** obscures part of the LCD **25**, providing opposing triangular sections **82**, **83** that are used to indicate battery capacity and signal strength respectively.

To complete the structure, the casing **2** has a rear cover **21** and internal compartments **84**, **85** suitable for retaining the engine **24** the battery **79** and in this embodiment a SIM card **81**. The device illustrated, in common with many other radio telephones, advantageously allows access to the battery compartment **85** as the battery **79** may periodically need replacement. In order for the engine **24** to be protected during this activity, the battery **79** is retained in a compartment providing connectors to the engine **24**. Along side the battery compartment **85** in this embodiment is the SIM card holder **80**. Under protocols where a SIM card **81** is used to hold subscription information, the user may wish to remove the SIM card **81**. For this reason it is convenient for the back cover **21** to be removable to expose both the battery **79** and the SIM card **81**. The battery compartment **85** and SIM card holder **80** are provided by an internal casing element **87** that is secured to the side frame **20**. This may be formed from plastic or one of many other suitable materials. In one embodiment the compartments are formed from stamped metal sheet which may be stainless steel.

The battery contacts **90** protrude into the battery cavity **85** to provide a simple way of connecting the battery **79** to the engine **24**. The battery connection will typically have a power connector **91**, a ground **92** and two signal connectors **93**, **94**.

In the embodiment illustrated, the power **91_{a,b,c}** and ground **92_{a,b,c}** connectors are divided into three. This reduces the resistance between the battery **79** and the engine **24** as the leads are in parallel, it also reduces the chance of power being lost to the engine **24** as a result of a harmonic resonance frequency of the connector being reached as at all times there is likely to be at least part of each three part connector completing the circuit between the engine **24** and the battery **79**.

The casing **2** is completed by assembling the back cover **21** to the side frame **20**. In the illustrated embodiment, the back cover **21** is formed from three pieces **96**, **97**, **98**. A first piece **96** overlays the antenna location. In this embodiment it provides an aperture **99** in which the polyphonic speaker **27** is located to provide for polyphonic sound. This additional speaker **27** has not been optimised for use in close proximity to the ear as has the speaker **18** located beneath the pillow **16**. This allows it to be more effective as a handsfree speaker and enables a greater range of ring tones to be utilised. As the first piece **96** also covers the antenna its dielectric constant is relevant.

In a device of this type where the casing **2** is to survive generations of engines **24**, the materials from which is formed are important. They should be hard wearing and durable, retaining their attributes for years longer than is currently required. For this reason ceramics have been considered as an option for the back cover **21** for some embodiments of the invention. Other materials already discussed such as metals or precious metals or veneers would also be possible. With

ceramics, however, despite having many desirable characteristics, for locations near an antenna relevant for devices containing such an element, the dielectric constant of the material interferes with the desired transmission pattern.

To provide many of their desirable characteristics without the dielectric constant becoming too high, the rear cover piece **96** can be formed from a material with a lower dielectric constant with a suitable depth of layer deposited on it. This technique and suggested materials could be used for other elements of the casing.

The rear casing element **96** covering the antenna is again screwed to the side frame element **20** and in the process captures the second rail **23** similar in construction to the first rail **22** between the side frame **20** and the back cover **21**. Again the rail **23** is provided with apertures **70** that are positioned over corresponding projections **71** on the side frame **20** to more securely hold the rail **23** in position when the back cover **21** is attached.

A second rear casing element **97** covers the battery compartment **85** and the SIM card holder **80**. This element is releasably secured to the other casing elements using screws **99** to allow relatively easy access to the SIM card **81** and battery **79**. In a preferred embodiment a quarter turn of a screw **100** releases the cover element **97** to allow it to be removed. The same action can disconnect the battery **79** to allow the SIM card **81** to be removed.

The second rear casing element **97** is attached to the side frame **20** in a similar manner to that described in relation to the first rear casing element.

The third element of the rear casing **98** covers the handsfree speaker **27**. This may be only relatively thin and formed from a precious material such as gold. It will be provided with a suitable aperture **102** to channel sound from the polyphonic speaker **27** that may be used in hands free mode and for providing an audible ring tone.

In the embodiment described the front **3** and rear casing elements **96**, **97**, **98** are secured to the side frame **20**. A silicon sealant **69**, or similar, may be extruded around the inside of the back cover **21** to prevent unwanted ingress of dirt and fluid.

The skilled man will realise that the number of parts and the manner in which they are connected can be changed without departing from the several inventive concepts described. For example, in other embodiments the casing may be held together using other techniques and in other ways.

As well as obscuring exposed edges, the rails **22**, **23** provide additional elements for customisation as they can be formed from a variety of different materials, in particular different types of precious metal for example gold or platinum as discussed previously in relation to the bezel. The material for the entire 'T' shaped piece or the extruded element could be a precious metal. They also act to protect vulnerable edges of veneered frames from exposure to potentially damaging forces. In doing this unsightly edges are obscured from view. This provides quality and durability in keeping with the overall concept of a retainable casing for a communications device. Regardless of the material of the veneer, this is a convenient arrangement for securing all the elements in place for a durable finish.

In an alternative embodiment illustrated in FIG. **4b**, instead of providing rails **22**, **23** to protect exposed edges, the adjacent edges themselves are turned inward **105**, **106** and held in close proximity. This arrangement also provides the advantage of protection and keeps unsightly discontinuities from view.

A casing with an optically permeable front face provides new opportunities. In a particular embodiment, described

11

with reference to FIGS. 12 and 14 legends 15 associated with the keys of the key array 6 are located on both the front 37a and rear 37b surfaces of the Perspex layer 37. With communications devices becoming ever more sophisticated, it is common for each key provided to have a number of different functions. It is useful to be able to label visually the different possible functions associated with a key. For the alpha numeric keys 7 in particular, each key is associated with a single digit and a group of letters or symbols. Ideally these should be displayed clearly.

Historically the keys have held the associated legends. As devices have become smaller this has, however, become more difficult, it being an especial problem to distinguish between the different legends for respective modes of operation as the letters and numbers are so small. In the illustrated embodiment, the legends 15 for associated keys are located on respective surfaces of the light guide 14, which as the device is tilted, move together or apart depending upon the angle from which they are viewed. This provides a visual distinction between the legends 15 on the different surfaces which can be used to distinguish between the modes of operation. As the front face is optically permeable, the legends appear to float in or above the device. By spacing the legends along an axis perpendicular to the third dimension, the thickness of the front face, the front face is given some prominence, thus an additional dimension has been added to the normally opaque front face.

In the embodiment illustrated the legends 15 are located on the outermost and innermost surfaces of the Perspex layer 37a, 37b. The legends 15 appear to be floating in the light permeable layer. The manner in which the legend 15 is located on the layer is a matter of choice for the skilled man. One method is to print the legend on to the surface using an etched plate filled with ink. Another way may be by using PVD (Physical Vapour Deposition) techniques to deposit the 'printing' directly onto the Perspex layer. Other techniques for fixing legends could be used including attaching labels.

In the embodiment discussed the legends 15a 15b are located on opposing surfaces of the Perspex layer 37a 37b. This enables a single element, the Perspex layer 37, to be printed instead of each of the sapphire or other pieces 52-58. Problems encountered with ink wearing off when printing techniques are used are also avoided by protecting the surfaces containing the printing with the second layer. In other embodiments and to increase the depth of spacing of the legends and hence the separations possible when viewed at different angles it may be desirable to place the legends on the innermost 37a and outermost surfaces 51a of the composite. In order to fix the legend 15 printed on the outer surface 51a where it may encounter wear, a coating or other protective layer may be provided over the surface. This may not be necessary if PVD techniques are used to produce the legend 15 as such techniques produce a bond between the deposited layer and the substrate that is more hard wearing. In still other embodiments the legend 15 could be provided on the underside 51b of the sapphire elements and on the innermost layer of the Perspex substrate 37b. Again by avoiding the external surfaces of the transparent layer the problem of wear of the legends 15 is largely avoided. The outermost legend is protected by the top layer 51 of the composite light guide 14 and the innermost legend 15 is not accessible.

In sandwiching the legends between two optically permeable layers 37, 51 which of the two sandwiching layers carries the legend is largely immaterial. The properties of the respective materials, if indeed they are different, and other factors can be taken into account in deciding which layer 37b, 51b actually carries the legend. With a composite optically per-

12

meable substrate, the more layers that are provided, the more visually distinguishable legends can be accommodated. For example with two composite layers there are three available planes for legends, with three layers, four planes and so on. If all the legends were placed adjacent a single key, the visual distinction may cause difficulty with large numbers of layers being used to distinguish functionalities. Other embodiments could use the different planes for legends at different locations on the device so that one set of keys has a legend in a first plane, a second set of keys in a second plane and so on.

To accentuate the illusion of the legends floating, or to increase the distinction between the two layers, the thickness of the optically permeable layer between the respective layers carrying the legends can be increased. In the same way these features can be reduced by decreasing the thickness between the planes carrying the legends.

The ink or paint can be chosen by the skilled man to provide a number of effects. The ink may, for example, be required to pearlesce or fluoresce, or be black, white, or one or more of a wide range of colours. As the legend is located on a light guide, fluorescent and pearlescent materials enhance the visibility of the legends. The type script, colour or other character of the legend or element carrying the legend may be selected by a commissioning party.

Instead of techniques that add ink or other visible materials to the surface merely etching the layers may be sufficient to make the legends visible if the illumination is adequate.

Embodiments illustrating the location of legends associated with keys in a light permeable face has been described with reference to the illustrated embodiments in the context of other independently inventive features claimed in copending applications. The skilled man will realise that many alterations to the specific features disclosed can be made without departing from the scope of the invention.

The input region of the device will now be described in more detail, primarily with regard to FIGS. 9 and 15 to 21

The input region 5 comprises a key array 6, as described above. In this embodiment, the key array is made up of a plurality of individual keys 7-13. Each of these individual keys comprises a key tip 64 and shaft 49 extending from substantially the centre of the key tip 64, together with an upper bearing 103, O ring 107, circlet 108, spring plate 110 and lower bearing 109 positioned respectively along the shaft 49a from the key tip 64. The spring plate 110 is supported by a spring plate support 114 provided on the PCB 118. The spring plate comprises a main body, and a tongue 111 formed from a single piece of sheet metal. The tongue has been formed by stamping an inner portion of the sheet, so that two sides and an end of the tongue are free from the remaining main body of the sheet. The spring plate also has a portion or portions stamped out to provide an aperture for the key shaft 49 and spring plate support 114. One end 113 of the spring plate comprises contacts for contacting respective contact regions on the PCB. As will be appreciated by a person skilled in the art, a single contact could be used for this purpose, but the provision of two contacts provides greater reliability. The spring plate support 114 comprises three members upstanding from the PCB 118. These members may form part of a unitary structure, or may be separate elements. The first member comprises a recess 115 dimensioned to receive one end 112 of the spring plate 110 and hold that end 112 in position. The second member of the support 114 comprises a lip 116 extending towards the first member. This lip 116 is provided to restrict the upward movement of the other end 113 of the spring plate 110. The third member of the support 114 comprises a recess 117 for receiving the end of the tongue. This third member is positioned relative to the second member,

13

such that the tongue of the spring plate **110** has to be flexed in order for the end of the tongue to correspond with its recess **117**. Optionally, the spring plate support may comprise a fourth member comprising a lip extending towards the second member. In this case, the PCB contact regions are extended to the surface of this lip, so as to bring them closer to the spring plate contacts. Alternatively the contact region bearing lip may be formed as part of the second member itself, or eliminated altogether.

As mentioned above, in the present embodiment, the individual keys are grouped in threes, their tips extending across the whole width of the second layer of the composite **51**. This facilitates manufacture of the brittle elements **52** to **58**. The tips of the alphanumeric keys **7**, soft keys **8**, **9** and top scroll key **12a** are in alignment with those of the other keys in their group. In the remaining group of keys, however, the tip of the bottom scroll key **12b** is displaced from the line of the tips of the other two keys in its group, namely the call handling keys **10**, **11**. In any event, in each group the edges of adjacent key tips complement each other, and are closely spaced. This eliminates the need for the composite **51**, or other filler material, to extend between the key tips. It also has the advantage of simplifying the overall appearance of the input region of the device to the user. Further properties and advantages of the specific key array **6** will be discussed below.

As can be seen in particular from FIGS. **17** and **18**, the spring plates **110** and supports **114** of adjacent alphanumeric keys **7** are positioned perpendicular to each other. This provides a geometrically simple solution to the problem that the spring plates cannot be positioned in alignment with the keys themselves. One cause of this problem in the embodiment illustrated is that the spring plate of each outer key is longer than the average length of its corresponding key tip, and this extra length cannot be accommodated elsewhere. This is primarily because the spring plate of each central key is only minimally smaller than the average length of the corresponding key tip, and the keys are closely abutted (there is only a gap of about 0.245 between the keys) so that there is insufficient space to allow for the extra length. Furthermore, whilst the key shaft **49** of each key is substantially central to the key tip **64**, the key shaft aperture of the spring plate **110** is off-centre. This exacerbates the problem for the outer keys, and even results in the spring plate of each centre key not being able to be accommodated in the space under its corresponding key tip.

The keys may be constructed, and the input region of the device assembled as follows. Upper bearings are inserted into the apertures **48** of the perspex layer of the device. Ruby bearings are preferably selected for this purpose, for three main reasons. Firstly, ruby is very hard wearing, and will thus be able to handle multiple operations of the keys over a substantial period of time. Secondly, the upper bearings of this device are larger in diameter than the corresponding widths of the key tips, which means that they will be visible in situations in which the front face of the device is transparent (e.g. second layer **51** may be sapphire). Hence, advantage may be taken of the fact that a ruby is an attractive jewel, which the user will be pleased to see. Thirdly, the use of a hard material such as ruby will provide greater accuracy of fit of the key in the device, as opposed to using a resilient material, such as PTFE.

Lower bearings **109** are provided in a titanium plate which is fixed to the rear of the PCB **118**. The inner and outer diameter of the lower bearings **109** are smaller than the upper bearings **103**, but their centres are aligned. They are also

14

preferably made of different material—the material of the lower bearings having shock absorbing qualities such as PTFE.

The key shafts **49** are machined, to have a first portion **49a** of appropriate thickness to pass through the inner diameter of the upper bearings **103** and a second reduced diameter portion **49** to pass through the inner diameter of the lower bearings **109**. Shaft **49** and cirlet **108** may be machined from a single piece of metal, or the cirlet **108** may be subsequently attached to the shaft **49**. They are preferably formed of stainless steel. Further, an O ring **107** is provided adjacent the cirlet **108**, on the thicker diameter portion **49a** of the shaft **49**, to provide a water seal. Both the cirlet **108** and the O ring have an outer diameter smaller than that of the upper bearing, so that they are not visible to the user when in situ. However, the cirlet has an outer diameter sufficiently larger than the inner diameter of the upper bearing, so as to prevent the key from falling out of the device.

The key tips are crafted into the desired shape from a desired material, which may be a metal such as gold, platinum, silver, or stainless steel. They may also bear precious stones. For example a key tip or tips may be diamond encrusted, or have a precious stone set in it. Once a key shaft has been passed through an upper bearing, a key tip is joined to it. This may be achieved using conventional braising techniques.

The spring plate supports **114** are provided on the PCB **118**. Each spring plate support **114** is preferably of unitary structure, manufactured from lightweight metal such as aluminium. The supports may then be soldered onto the PCB using conventional techniques. The spring plate supports **114** are positioned to hold the spring plates **110** so that the centres of their shaft apertures align with those of the lower bearings **109**. Contact regions for the spring plate contacts are provided on the PCB (or the lip of the second or fourth member of the support as described above).

The spring plates **110** themselves are provided by stamping sheet metal, such as beryllium copper with gold flash or the like. The plates **110** are affixed to the supports **114** by positioning one end **113** of the spring plate under the lip **116** of the second member of the support **114**, fitting the other end **112** of the spring plate in the recess **115** of the first member of the support **114**, flexing the tongue so that its end corresponds to the recess **117** of the third member of the support **114**, and positioning the end of the tongue in that recess. When in position, the free end **113** of the spring plate **110** is naturally biased upwards toward the restraining lip **116**.

The dimensions of various components of the keys and their relative positions are important in smooth key operation. The distance between the upper and lower bearings has been maximized by placing them either side of the spring plate switching mechanism and passing the shaft through the spring plate. In such a position, the bearings hold the key straight when it is operated, thereby avoiding contact with neighboring key tips or the need to place keys further apart to prevent such contact. This, in turn, results in good switching functionality and feel.

Also, the dimensions of the keys are such that the lower surface of each key tip **64** contacts the surface of the perspex layer **37** before excess pressure can be applied to the spring plate **110**. In the present embodiment, the cirlet **108** is positioned along the shaft such that it gently rests on the spring plate when the keys are in their normal non-depressed state. Also, the thicker portion of the shaft is of an appropriate length that, when in the normal state, there is a gap between the lower surface of the key tips and the surface of the perspex layer **37** which is the same as, or only slightly greater than the

15

distance the circlet **108** has to travel to cause the spring plate contacts to contact the contact regions. This overcomes a potential problem of pressure being applied to the spring plate if the switch itself provides the end stop for the motion.

The dimensions of the keys are also important for the external appearance of the device. Preferably, the key tips are of a thickness that they protrude from the surface of the second layer **51** of the composite, at least when the keys are in the aforementioned normal state. When the composite is substantially transparent, this will give the impression of floating keys, and add to the three dimensional effect mentioned earlier concerning the key legends **15**. Furthermore, the key tips should be sufficiently deep to be partially sunk into the second layer of the composite, and preferably have at least two opposing substantially flat sides which correspond with sides of the second layer to prevent lateral rotation of the keys. A gap of the order of 0.1 mm is achieved in the present device between the keys and second layer of the composite: a gap insignificant to the human eye and suitable for assisting in the prevention of lateral rotation of the keys. Lateral rotation is further hindered in the present embodiment, by virtue of the provision of mirrored slanting of the sides of adjacent keys.

In order to ensure the correct relative spacings of elements of the key, the perspex layer **37**, PCB **118**, and titanium plate **77** are clamped together. In this embodiment, the clamping is provided by the front face protectors **63**, and by the provision of additional tapped bosses in projections **68** of the perspex plate and associated fixing means. Consequently, once the keys have been positioned, the perspex layer, PCB and titanium plate can be clamped together using the bosses and fixing means, thereby holding the keys in place and forming a manageable module. This module may then be readily installed in the device using the front face protectors as described above with reference to FIG. **9B**.

Operation of the keys of the device will now be described. As the user applies pressure to a key tip, the shaft moves downwards, travelling through the bearings and shaft aperture of the spring plate. This results in the circlet applying pressure to the part of the main body of the spring plate which defines the shaft aperture. Continued pressure on the key tip will then cause the circlet to apply an increasing force to this part of the spring plate, causing the main body to deform around the circlet. Eventually, this deformation will cause the tongue to overcentre, resulting in the free end **113** of the spring plate **110** flicking from its naturally biased position (upwards towards the restraining lip **116**) to a second position, in which the spring plate contacts contact the contact regions on the PCB. An electrical signal is consequently sent to the processor indicative of actuation of that key. This arrangement gives a distinct click providing a clear quality indication to the user that the key has been actuated. As the user removes pressure from the key tip, the circlet, in turn, removes pressure from the spring plate **110**. The tongue promptly returns to its normal position, and the free end of the spring plate flicks up to its naturally biased position, breaking the contact.

FIG. **20a** is a graph illustrating the force against distance profile for a key such as that illustrated in FIGS. **17** and **18**. This profile improves the tactility of the key over, for example, a typical keydome arrangement, which had a fairly flat profile as can be seen in FIG. **20b**. When using a conventional key dome type arrangement, the user has to apply a constant force until the point where the key actuates. As a result, he does not get a tactile indication that he is nearing the position when actuation is likely to occur. In contrast, when using the device illustrated in FIGS. **17** and **18**, the user can realise the fact that he is nearing the position when actuation

16

is likely to occur as he is having to increase the force applied for a given travel of the key. Furthermore, the user is informed when actuation takes place, and again when deactuation takes place, by respective clicking sounds provided by the key.

The central V shaped key tips of the embodiment illustrated in FIG. **1** enable the user to determine the central vertical axis of the device both by sight and by touch. This is made even easier by the pillow **16** being provided with an apex. Consequently the user can quickly locate a desired central key. The apexes of each central key tip also identify the mid point along the length of the key tip, the point from which the key shaft **49** extends. Hence, they facilitate more accurate depression of the key. This, in turn, may assist in the prevention of contact with neighboring key tips or the need to place keys further apart to prevent such contact.

Likewise, in this embodiment, the combination of adjacent outer key tips and front face protectors forming a V shape enable the user to determine the position of the vertical axes to one side of which the outer keys lie. Consequently, the user can quickly locate a desired outer key. The key location process is facilitated in this embodiment as the outer key tips extend to the interface between the second layer of the composite **51** and the bezel **19**.

The front face of the device illustrated in FIG. **1** is protected by the pillow and front face protectors, **63**. The front face **3** is slightly convex, with the highest points lying along its central longitudinal axis. Hence, ordinarily, if placed face down, the device would rest on this axis, resulting in scratches to its surface. Clearly, this is not acceptable, particularly when the second layer of composite is sapphire or the like. The device illustrated in FIG. **1** has been designed to avoid this problem. The pillow **16** and face protector **63a** prevent the device resting on the second layer of composite. Also, as mentioned above, in the preferred embodiment the key tips protrude slightly from the surface. Hence, the central key tips too may protect the second layer of composite from damage. However, preferably the pillow **16** and chin front face protector **63a** are raised sufficiently above the front surface, that the device does not rest on the central key tips either, so as to protect them from damage too.

The device is also designed so that the front face is protected if the edge of the face is knocked. As can be seen from the plan view of the device, depicted in FIG. **21**, the bezel front face protectors **63b** protrude beyond the surface of the second layer of composite along the interface with the bezel, thereby protecting the second layer of composite from damage in that region. They also reduce the likelihood of damage to the bezel due to knocks. Moreover, they protrude further than the adjacent key tips, hence protecting those key tips from damage too.

One further benefit of the front face protectors **63**, particularly the bezel is that they are dimensioned so as to prevent the keys from being accidentally actuated if, for example, the device was placed face down. That is, the top surface of the front face protector tips should either be at the same level or higher than the top surface of a key tip (e.g. as in the relationship between the protectors **63b** and the adjacent outer key tips) or, if they are at a lower level than the top surface of a key tip, the distance between the top surface of the protector and key tips must be smaller than the distance the key needs to travel in order for the spring plate contacts to contact the PCB contact region for actuation the key.

Aspects of the invention have been discussed with reference to a radio telephone function. It will be clear to the skilled man that these aspects apply equally to other portable communications devices supporting in addition or as an alter-

native other functions, such as, amongst others electronic diaries, and electronic notepads.

The skilled man will be aware that the materials described above in relation to specific elements of the device can be mixed and matched to suit many distinct design options.

In order to commission a casing for a portable communications device there will be a list of designated casing elements the characteristics of which are selectable by a commissioning party. This list of possible parts for personalisation may be provided in amongst other ways on a computer, on a web site or as a paper list in a suitable store. The party commissioning the device can then select the characteristics of the designated elements from a set of possible options provided. In alternative embodiments the scope for originality in the characteristics of individual ones of the designated elements may be greater and the commissioner may be given a practically free hand in determining the material, and other additions such as surface decoration by etching or engraving and, amongst other things, encrustation.

The entire process could be computerized so that the selected characters of the device are readily conveyed to a manufacturing location or location for realization of the selected characters for the designated elements. This could be via an intermediary that records the customers specifications for later use and utilizes the skills of a range of craftsmen to make the required elements and co-ordinates the collocation of the individual elements for assembly. The device will be described in greater detail below with exemplary materials being given for specific elements of the device. Where a material or veneer is discussed in relation to an element, the reader should be aware that the particular character of the element described is one of many or several that may be provided as options to a party commissioning a personalised device. In addition the exact material or surface decoration of the element could be individually commissioned. As another option the specification of the commissioner could be directly forwarded to a location with the selected elements in stock for immediate assembly. In this embodiment either individually commissioned elements would not be possible at all or restricted to a relatively small number of tasks that can be performed after the initial materials and finish of an element have been decided, such as engraving and possibly jewel encrustation.

For greater freedom in individually commissioned elements, these elements could be individually designed and fabricated and finally forwarded for assembly with the less unique elements. Should assembly of the elements require particular skills or for perhaps other reasons the assembly may occur at yet another location.

The formed article is then conveyed to the end user.

The present invention includes any novel feature or combination of features disclosed herein either explicitly or any generalization thereof irrespective of whether or not it relates to the claimed invention or mitigates any or all of the problems addressed.

In view of the foregoing description it will be evident to a person skilled in the art that various modifications may be made within the scope of the invention.

The invention claimed is:

1. A casing for a portable personal communication device defining an internal space for accommodating an engine, the

casing including an outer front face carrying a user interface having a plurality of user input elements and an outer rear face, the outer front face of the casing comprising at least one casing element formed from a material from a first group consisting of precious metal, precious stones and ceramics, and the outer rear face of the casing comprising at least one casing element formed from a material from a second group consisting of precious metals and ceramics.

2. The casing according to claim 1, wherein the at least one casing element of the outer front face is a display window formed from a precious stone.

3. The casing according to claim 2, wherein the display window comprises sapphire or diamond.

4. The casing according to claim 1, further comprising a bezel surrounding the outer front face.

5. The casing according to claim 4, wherein the bezel is made from a precious metal.

6. The casing according to claim 1, wherein the user input elements are keys.

7. The casing according to claim 6, wherein the keys comprise key tips made from a precious metal.

8. The casing according to claim 1, further comprising at least one front face protector.

9. The casing according to claim 8, wherein the at least one front face protector is made from a precious metal.

10. The casing according to claim 1, wherein the precious metal is a metal including gold or silver or platinum.

11. The casing according to claim 1, wherein the precious metal is an alloy.

12. The casing according to claim 1, wherein the outer front face of the casing comprises a further casing element formed from a precious metal.

13. The casing according to claim 1, wherein the casing is configured to enable the engine to be upgradeable by replacement.

14. A method, comprising providing a precious casing of a portable electronic device and a first generation electronic device engine for housing within the precious casing; and subsequently providing a second generation electronic device engine for replacement of the first generation electronic device engine housed within the precious casing.

15. The method according to claim 14, further comprising, before providing the precious casing, enabling a computer implemented selection of a design of the precious casing to be made.

16. The method according to claim 14, further comprising, before providing the precious casing, enabling a computer implemented commissioning of a design of the precious casing to be made.

17. The method according to claim 14, wherein the second generation electronic device engine has greater processing power than the first generation engine.

18. The method according to claim 14, wherein the portable electronic device is a portable communication device.

19. The method as according to claim 14, wherein the portable electronic device is a portable radio telephone.