

US007821159B2

(12) **United States Patent**
Day

(10) **Patent No.:** **US 7,821,159 B2**
(45) **Date of Patent:** **Oct. 26, 2010**

(54) **METERING PUMP POWER SOURCE**

(75) Inventor: **Thomas Day**, Riverside, NJ (US)

(73) Assignee: **Milton Roy Company**, Ivyland, PA (US)

(*) Notice: Subject to any disclaimer, the term of this patent is extended or adjusted under 35 U.S.C. 154(b) by 273 days.

(21) Appl. No.: **12/218,426**

(22) Filed: **Jul. 15, 2008**

(65) **Prior Publication Data**

US 2010/0013310 A1 Jan. 21, 2010

(51) **Int. Cl.**

H02J 7/00 (2006.01)

H02J 9/00 (2006.01)

(52) **U.S. Cl.** **307/65; 307/64; 307/66; 307/80**

(58) **Field of Classification Search** **307/65**
See application file for complete search history.

(56) **References Cited**

U.S. PATENT DOCUMENTS

6,372,978 B1 4/2002 Cifaldi

6,559,552 B1	5/2003	Ha	
6,712,906 B2 *	3/2004	Estelle et al.	118/683
6,768,285 B2 *	7/2004	James	320/104
2003/0071597 A1	4/2003	James	
2006/0137348 A1	6/2006	Pas	
2008/0231119 A1 *	9/2008	Yeh	307/65

OTHER PUBLICATIONS

Rex A. Ewing, "Power With Nature: Solar and Wind Energy Demystified," pp. 230-231 (2003) PixyJack Press, LLC.

* cited by examiner

Primary Examiner—Hal I Kaplan

(74) *Attorney, Agent, or Firm*—Kinney & Lange, P.A.

(57) **ABSTRACT**

A power supply system includes an energy generator and an energy storage system, each electrically connected to a power bus. The power bus provides electrical power to a load. The energy generator includes a wind turbine and a solar panel. The energy storage system includes a storage device and a regulator. The regulator is configured to transfer energy from the power bus to the storage device when the power bus exceeds a maximum voltage and to transfer energy from the storage device to the power bus when the power bus drops below a minimum voltage.

25 Claims, 2 Drawing Sheets

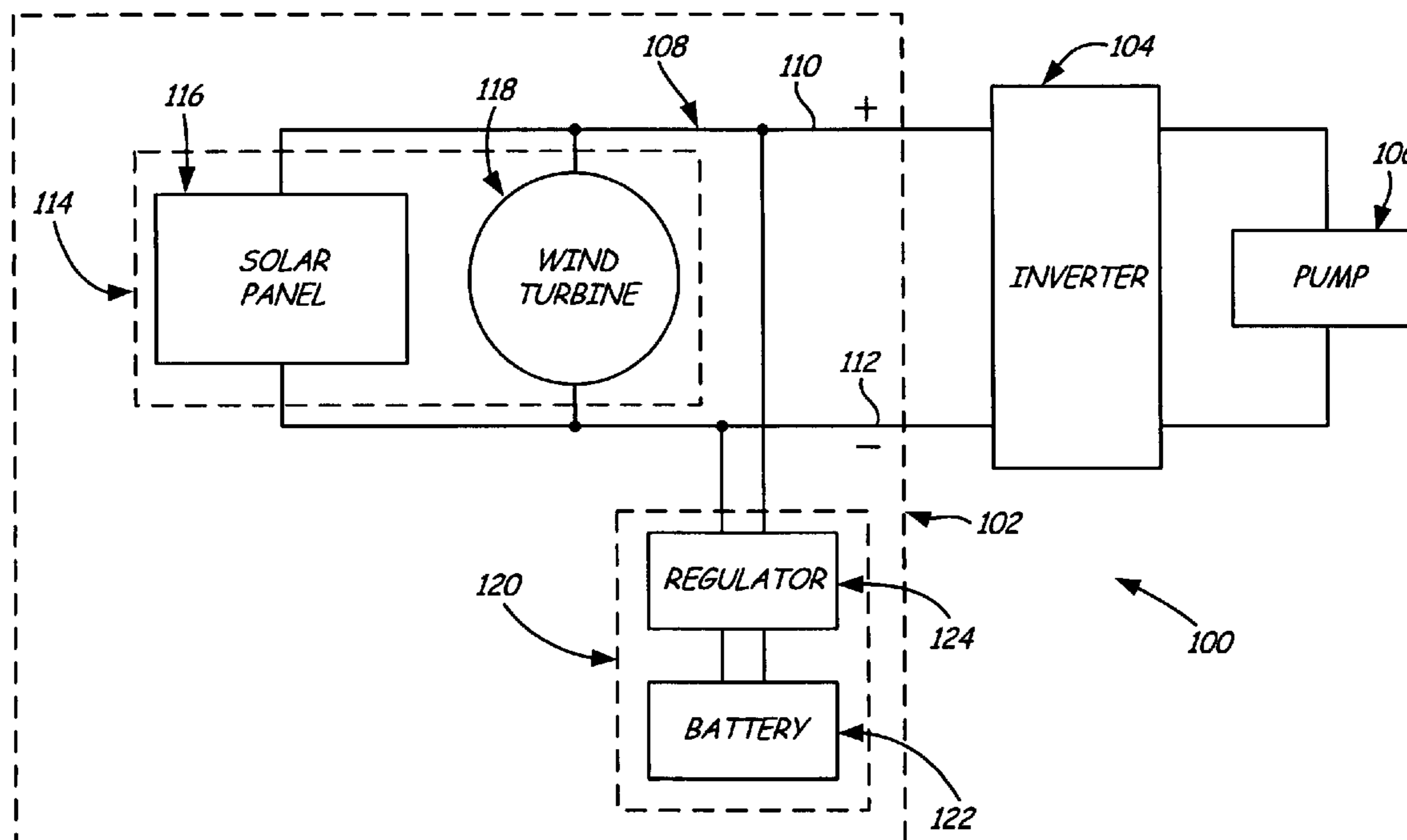

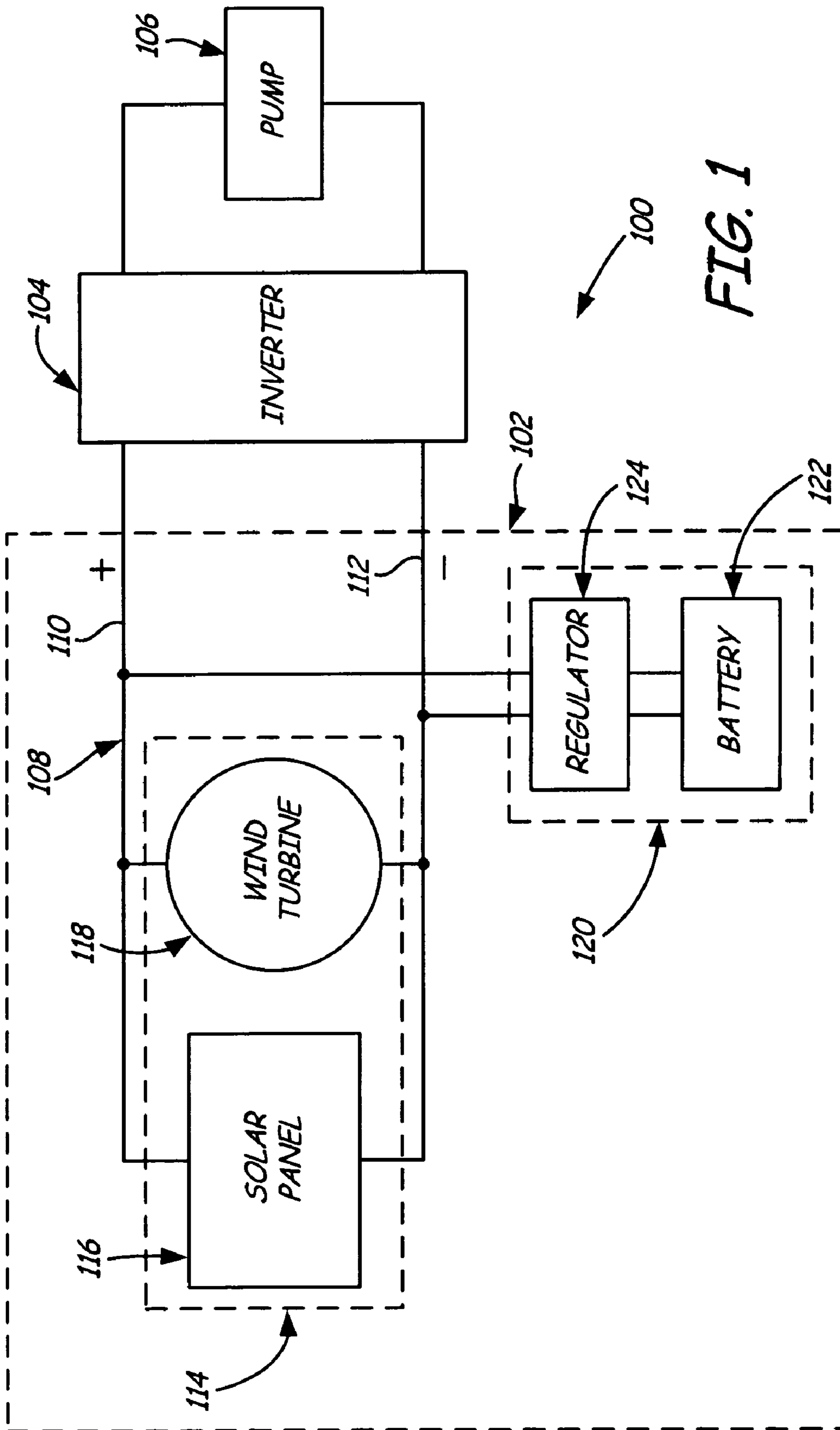

FIG. 1

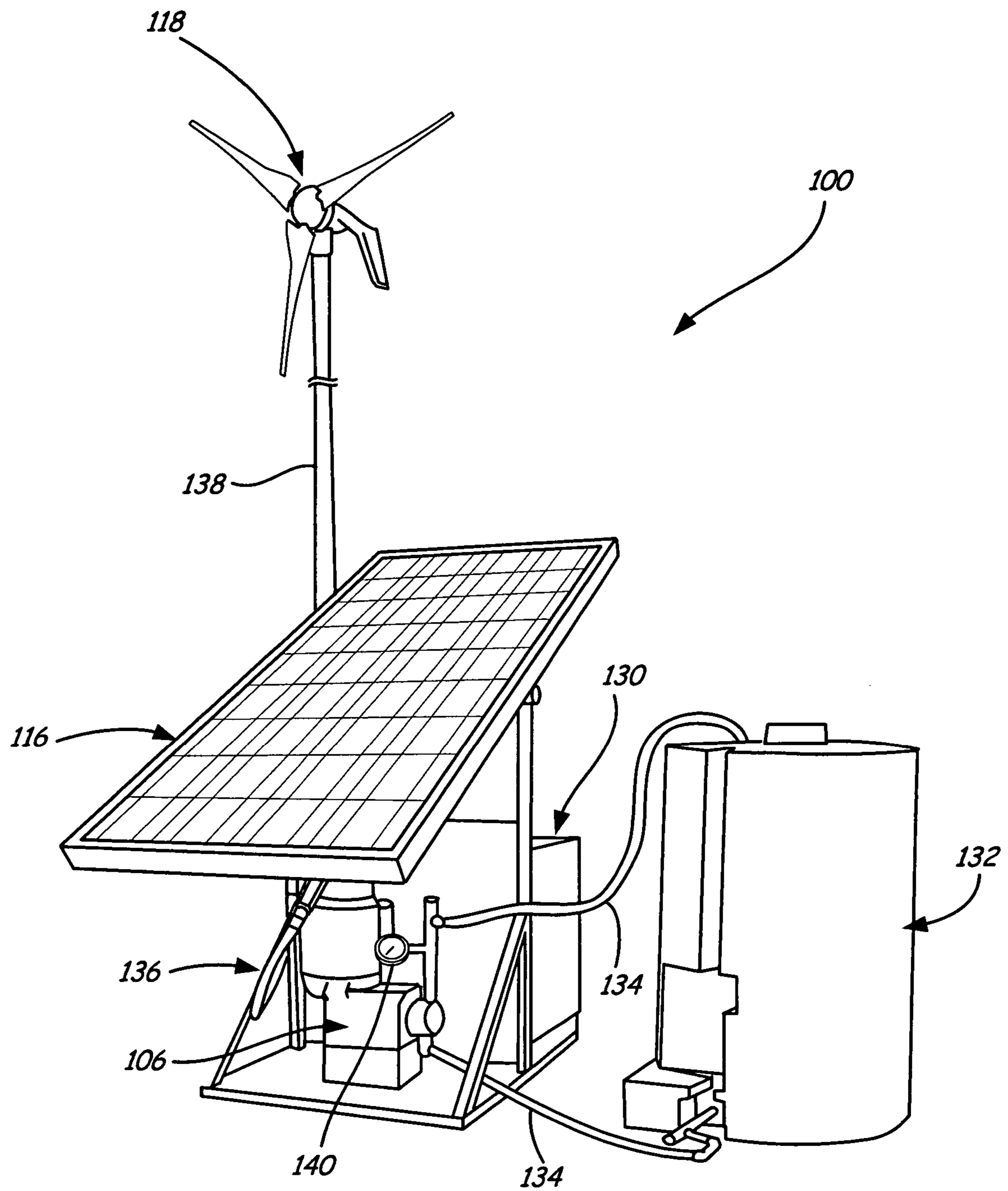

FIG. 2

METERING PUMP POWER SOURCE

BACKGROUND

The present invention relates to power sources, and more particularly, to power sources for metering pumps of chemical dosing systems.

Metering pumps provide high pressure chemical dosing for various needs. Typically, metering pumps run on electric power. In certain circumstances, metering pumps are needed in areas where electrical power is either not available or compromised, such as oil and gas pipelines, remote water treatment, on-site water disinfection, and localized odor control. In such circumstances, electrical power is typically provided by a gasoline or diesel generator.

“Green” power sources that can harvest energy from nature without combustion of hydrocarbons have long been available. Examples of green power sources include solar panels and wind turbines. Typically, green power sources first harvest energy from nature; second, the power source transfers the energy to an electric battery; third, the electric battery powers a particular load device. The power source, electric battery, and particular load device are typically connected in series.

When a specific green power source is chosen to power a particular load device, certain assumptions are made. First, it is assumed that there will be extended periods of time when nature will not provide power to be harvested. For example, it is assumed that solar energy will not be available at night. Second, it is assumed that the particular load device may operate for a continuous period of time at its maximum rated power draw. Both of these assumptions are used when choosing the type and size of power source and battery for a given application.

SUMMARY

According to the present invention, a power supply system includes an energy generator and an energy storage system, each electrically connected to a power bus. The power bus provides electrical power to a load. The energy generator includes a wind turbine and a solar panel. The energy storage system includes a storage device and a regulator. The regulator is configured to transfer energy from the power bus to the storage device when the power bus exceeds a maximum voltage and to transfer energy from the storage device to the power bus when the power bus drops below a minimum voltage.

BRIEF DESCRIPTION OF THE DRAWINGS

FIG. 1 is a schematic view of the chemical dosing system of the present invention.

FIG. 2 is a perspective view of the chemical dosing system of the present invention.

DETAILED DESCRIPTION

In general, the present invention provides a green energy generator and an energy storage system for powering a metering pump. The size and type of green energy generator is chosen, specifically to power a particular metering pump at a particular location, for a particular operation. The size and type of energy storage system is chosen to supplement the power provided by the green energy generator, when needed.

FIG. 1 is a schematic view of chemical dosing system 100. Chemical dosing system 100 includes power supply system

102, inverter 104, and pump 106. Power supply system 102 supplies DC (direct current) power to inverter 104. Inverter 104 converts the DC power into AC (alternating current) power and supplies the AC power to pump 106 in those instances in which pump 106 includes an AC motor drive. Alternatively, if pump 106 has a DC motor drive, inverter 104 may be replaced by a DC/DC converter or a DC motor controller. Pump 106 is a metering pump and provides high pressure chemical dosing for a particular operation. In certain embodiments, pump 106 can be any of the following metering pumps manufactured by Milton Roy USA in Ivyland Pa.: mRoy A Series, LMI A Series, LMI P Series, or LMI E Series. In other embodiments, pump 106 can be virtually any pump that would benefit from the power source of the present invention. In still other embodiments, pump 106 can be replaced by another load device that would benefit from the power source of the present invention.

Power supply system 102 includes power bus 108 (having positive rail 110 and negative rail 112), green energy generator 114 (which includes solar panel 116 and wind turbine 118), and energy storage system 120 (which includes battery 122 (or other storage device) and regulator 124). Green energy generator 114 and energy storage system 120 are connected in parallel between positive rail 110 and negative rail 112.

Green energy generator 114, which includes solar panel 116 and wind turbine 118, is the primary source of power supplied to inverter 104 and pump 106. Solar panel 116 is configured to harvest solar energy emitted from the sun or other light sources and convert the solar energy into electrical energy. The function of solar panel 116 is well known in the art. Wind turbine 118 is configured to harvest wind energy and convert the wind energy into electrical energy. The function of wind turbine 118 is also well known in the art.

Energy storage system 120 includes battery 122 and regulator 124. Energy storage system 120 provides supplemental DC power to inverter 104 at times when green energy generator 114 is unable to meet the needs of pump 106. Battery 122 may include a single battery, multiple batteries, or other storage devices such as supercapacitors. Regulator 124 is configured to supply DC power from battery 122 to inverter 104 when the voltage between positive rail 110 and negative rail 112 drops below a minimum value. Regulator 124 is also configured to supply DC power from green energy generator 114 to battery 122 for storage when the voltage between positive rail 110 and negative rail 112 exceeds a maximum value. Typically, green energy generator 114 supplies DC power to battery 122 only when green energy generator 114 is generating power in excess of the needs of pump 106. Thus, battery 122 is not required to be an intermediary between green energy generator 114 and pump 106.

FIG. 2 is a perspective view of chemical dosing system 100. As depicted in FIG. 2, chemical dosing system 100 further includes instrument package 130, chemical tank 132, hoses 134, frame 136, mast 138, and meter 140.

Instrument package 130 houses battery 122 and regulator 124. Instrument package 130 is mounted to frame 136. Solar panel 116 and pump 106 are also mounted to frame 136. Wind turbine 118 is mounted to mast 138, which is mounted to frame 136.

Chemical tank 132 stores chemicals required for the particular operation. Chemical tank 132 is connected to pump 106 via hoses 134 to supply the chemicals to pump 106 as needed. Meter 140 is connected to pump 106 for measuring the amount of chemical supplied.

In the prior art, there has been one basic concept used for green power systems. This is to harvest the resource, store the

power, and only then use it as needed by a load device. This is defined here as “static” power harvesting. Static power harvesting is identified by a focus on backup storage, generally in the form of a battery or bank of batteries. An energy generator charges a battery, and the battery powers the load device. Various manufacturers have developed equations to calculate the amount of storage required to run the load device for a given time interval. As a result, some choice of storage is either calculated or specified, usually in hours to days, and a system is built around the storage requirement. The problem with designing a power supply system around batteries as the primary power source is that the energy storage requirements can become very large. Batteries are one of the weakest links in any system where they are employed. Adding more and larger batteries increases the risk of system failure.

Power supply system **102** of the present invention uses “dynamic” power harvesting. In dynamic power harvesting, load is calculated and the system is sized, based on real time harvesting of green resources. Green energy generator **114** supplies DC power directly to inverter **104** and pump **106** without using battery **122** as an intermediary. So long as green energy generator **114** can supply the needs of pump **106**, battery **122** need not provide any supplemental power. Thus, energy storage system **120** needs to be sized large enough to be a filler and energy conditioner, not a primary source of electricity. This significantly reduces the energy storage requirements.

Dynamic power harvesting uses the available natural resources in any given location to directly generate electricity to the load device. Reference for natural resource availability comes from, among other sources, the worldwide wind and solar intensity charts to determine the available power that can be harvested, balanced against the load requirements of the load device. In most circumstances where at least two green power sources (such as solar panel **116** and wind turbine **118**) are utilized, it is safe to assume that nature will provide power to be harvested at least 40% of the time in any 24 hour period. In other circumstances where at least two green power sources are utilized, it is safe to assume that nature will always provide power to be harvested, even though the quantity may sometimes be small.

The present invention has a significantly reduced power storage requirement of power supply system **102**, while providing the necessary power to the load device. Energy storage system **120** takes on the function of an intermittent power supplier and power signal conditioner rather than the main power source, as found in the static harvesting system. Dynamic power harvesting removes the focus from storage and places it directly on load requirements. This permits the delivery of electric power with little to no modification to the load device.

Dynamic power harvesting also assumes that there is a difference between the maximum power draw of pump **106** and the actual power draw of pump **106**. Ordinarily, pump **106** will only operate at its maximum power draw for brief periods, such as during startup. At other times, pump **106** can operate at a reduced actual power draw during continued operation. At still other times, pump **106** can be at rest, requiring zero power draw. Thus, over a period of time, the actual power draw will be less than the maximum possible power draw of pump **106**. Therefore, power supply system **102** can be sized for supplying enough power for the actual power draw with only brief periods of maximum power draw. Such a system can be smaller and less expensive than a system sized to support pump **106** constantly operating at maximum power draw.

Pump companies such as Milton Roy Americas use standard motors (such as a ¼ HP motor) in order to reduce costs. Fractional HP (horsepower) motors below ¼ HP are actually more expensive than the standard ¼ HP motor. Thus, certain pumps use motors with a greater than necessary capacity. Power supply systems do not, however, need to be sized to the motor’s maximum power when the motor operates at less than maximum power the majority of the time. Instead, power supply system **102** can be sized to the actual power draw of pump **106** with a safety factor.

In the case of solenoid driven pumps, the actual power consumption is published and typically ranges between 22 W and 90 W depending on the model. Therefore, the same methodology that is presented for motor pumps is not applicable but is more exact because the drive unit is sized exactly to the flow and pressure requirements.

Power supply system **102** can supply power to existing metering pumps (i.e. pumps originally installed with power supply systems different than the power supply system disclosed herein) without significant modification.

It will be recognized that the present invention provides numerous benefits and advantages. For example, an energy storage system sized to be a supplemental power source can be smaller and less expensive than an energy storage system sized to be the main power source. Further, smaller and fewer batteries decreases the risk of system failure. Moreover, using green power is less damaging to the environment than burning fossil fuels in a gasoline or diesel generator.

Although the present invention has been described with reference to preferred embodiments, workers skilled in the art will recognize that changes may be made in form and detail without departing from the spirit and scope of the invention. For example, other types of green energy could be harvested in addition to, or instead of, wind and solar power.

What is claimed is:

1. A chemical dosing system comprising:

a metering pump; and

a power supply system electrically connected to the metering pump, the power supply system comprising:

an energy generator comprising a wind turbine and a solar panel, wherein the energy generator is electrically connected to the metering pump and is a main power source for the metering pump; and

an energy storage system comprising a regulator and a battery, wherein the energy storage system is electrically connected to both the energy generator and the metering pump, wherein the energy storage system provides power to the metering pump when the metering pump requires power in excess of power provided by the energy generator, and wherein the energy storage system is sized to supplement an expected minimum power output for the energy generator during a 24 hour period so that power demanded by the metering pump is met during the 24 hour period.

2. The chemical dosing system of claim 1, wherein the energy storage system is sized to supplement a predicted power generation performance for the energy generator so that power demanded by the metering pump is met during all operating periods of the metering pump.

3. The chemical dosing system of claim 1, wherein the expected minimum power output for the energy generator is based upon historical wind and solar intensity data for a location of the chemical dosing system.

4. The chemical dosing system of claim 3, wherein the energy storage system is sized for operation in a location where an amount of solar energy available for harvesting by

5

the solar panel plus an amount of wind energy available for harvesting by the wind turbine is expected to be greater than zero at all times.

5 **5.** The chemical dosing system of claim 3, wherein the energy storage system is sized for operation in a location where an amount of solar energy available for harvesting by the solar panel plus an amount of wind energy available for harvesting by the wind turbine is expected to be greater than zero, 40% of the time in any 24 hour period.

6. A chemical dosing system comprising:

a metering pump; and

a power supply system electrically connected to the metering pump, the power supply system comprising:

an energy generator comprising a wind turbine and a solar panel, wherein the energy generator is electrically connected to the metering pump and is a main power source for the metering pump; and

an energy storage system comprising a regulator and a battery, wherein the energy storage system is electrically connected to both the energy generator and the metering pump, wherein the energy storage system provides power to the metering pump when the metering pump requires power in excess of power provided by the energy generator, and wherein the metering pump comprises a motor that operates at less than a maximum capacity over 50% of the time.

7. The chemical dosing system of claim 1, wherein the metering pump comprises a solenoid pump that operates at a maximum power draw for brief intervals spaced by intervals of reduced power draw.

8. The chemical dosing system of claim 1, wherein the energy generator supplies power to the energy storage system when the energy generator generates power in excess of the power required by the metering pump.

9. The chemical dosing system of claim 1, wherein the solar panel, the wind turbine, the energy storage system, and the metering pump are electrically connected to a power bus in parallel.

10. The chemical dosing system of claim 1, and further comprising:

an inverter for converting DC (direct current) power provided by the energy generator and the energy storage system into AC (alternating current) power for use by the metering pump.

11. A method for operating a power supply system, the method comprising:

harvesting solar energy with a solar panel, converting the solar energy to a first electrical energy, and supplying the first electrical energy to a power bus;

harvesting wind energy with a wind turbine, converting the wind energy to a second electrical energy, and supplying the second electrical energy from the wind turbine to the power bus;

combining the first electrical energy and the second electrical energy into a primary electrical energy;

supplying the primary electrical energy from the power bus to a load;

supplying excess primary electrical energy to an energy storage system for storage only if the primary electrical energy exceeds an amount of energy required to operate the load; and

supplementing the primary electrical energy with secondary electrical energy from the energy storage system when the primary electrical energy is insufficient to meet the amount of energy required to operate the load, wherein the energy storage system is sized to supplement an expected minimum power output of primary

6

electrical energy during a 24 hour period so that power demanded by the load is met during the 24 hour period.

12. The method of claim 11, wherein the load comprises a metering pump.

13. The method of claim 11, and further comprising the step of:

conditioning the primary electrical energy with the energy storage system.

14. A method for converting an existing metering pump to use green energy, the method comprising:

providing a green energy generator sized to act as a primary power source for the existing metering pump;

providing an energy storage system sized to act as a secondary power source that supplements power to the existing metering pump when power demanded by the existing metering pump exceeds power available from the green energy generator, wherein the energy storage system is sized to supplement an expected minimum power output for the green energy generator during a 24 hour period so that power demanded by the existing metering pump is met during the 24 hour period;

electrically connecting the green energy generator and the energy storage system to a power bus in parallel; and electrically connecting the existing metering pump to the power bus.

15. The method of claim 14, and further comprising the step of:

electrically connecting an inverter between the power bus and the existing metering pump.

16. A method for designing a power supply system for a pump, the method comprising:

determining an expected energy consumption of the pump for a particular operation at a location of operation;

selecting components for a green energy generator;

determining an expected energy generation performance of the green energy generator operating as a primary source of energy for the pump at the location of operation; and

selecting components for an energy storage system to provide supplemental energy to the pump during times when the green energy generator is unable to meet power demand of the pump, wherein the energy storage system is sized to supplement an expected minimum power output for the green energy generator during a 24 hour period so that power demanded by the pump is met during the 24 hour period.

17. The method of claim 16, and further comprising the step of:

selecting components for the green energy generator, wherein at least one component is selected from the group consisting of a solar panel and a wind turbine.

18. The method of claim 16, and further comprising the step of:

selecting a solar panel and a wind turbine as components for the green energy generator.

19. The method of claim 18, and further comprising the step of:

referencing wind and solar intensity charts for the location of operation of the green energy generator.

20. The method of claim 16, and further comprising the step of:

selecting a metering pump as the pump.

21. The method of claim 16, and further comprising the step of:

selecting a power bus capable of connecting the green energy generator and the energy storage system to the pump in parallel.

7

22. A power supply system comprising:
 a power bus for providing electrical power to a load;
 an energy generator electrically connected to the power
 bus, the energy generator comprising:
 a wind turbine; and
 a solar panel; and
 an energy storage system electrically connected to the
 power bus, the energy storage system comprising:
 a storage device; and
 a regulator configured to transfer energy from the power 10
 bus to the storage device when the power bus exceeds
 a maximum voltage and is further configured to trans-
 fer energy from the storage device to the power bus
 when the power bus drops below a minimum voltage,
 wherein the energy storage system is sized to supple- 15
 ment an expected minimum power output for the

8

energy generator during a 24 hour period so that
 power demanded by the load is met during the 24 hour
 period.

23. The power supply system of claim 22, wherein the
 5 energy storage system is sized to supplement a predicted
 power generation performance for the energy generator so
 that power demanded by the load is met during all operating
 periods of the load.

24. The chemical dosing system of claim 1, wherein the
 metering pump comprises a motor that operates at less than a
 maximum capacity over 50% of the time.

25. The method of claim 16, wherein the pump comprises
 a motor that operates at less than a maximum capacity over
 50% of the time.

* * * * *