



US007814656B2

(12) **United States Patent**
Prasad

(10) **Patent No.:** **US 7,814,656 B2**
(45) **Date of Patent:** **Oct. 19, 2010**

(54) **FLEXIBLE BARRIER FILM STRUCTURE**

(56)

References Cited

(75) Inventor: **Ravi Prasad**, Corvallis, OR (US)

U.S. PATENT DOCUMENTS

(73) Assignee: **Hewlett-Packard Development Company, L.P.**, Houston, TX (US)

5,656,714 A	8/1997	Shen et al.	
5,872,584 A *	2/1999	Hauck et al.	347/86
5,942,297 A	8/1999	Speer et al.	
5,975,686 A *	11/1999	Hauck et al.	347/85
6,015,524 A	1/2000	Kuder et al.	
6,146,764 A	11/2000	Soukas et al.	
6,196,669 B1 *	3/2001	Harvey et al.	347/85
6,268,026 B1	7/2001	Jester et al.	
6,312,772 B1	11/2001	Kuder et al.	
6,333,086 B1	12/2001	Ora et al.	
6,426,128 B1	7/2002	Kimmel et al.	

(*) Notice: Subject to any disclaimer, the term of this patent is extended or adjusted under 35 U.S.C. 154(b) by 1100 days.

(21) Appl. No.: **11/464,797**

(22) Filed: **Aug. 15, 2006**

(65) **Prior Publication Data**

US 2006/0274142 A1 Dec. 7, 2006

Related U.S. Application Data

(60) Division of application No. 10/346,528, filed on Jan. 17, 2003, now Pat. No. 7,132,152, which is a continuation-in-part of application No. 09/702,236, filed on Oct. 30, 2000, now abandoned.

(51) **Int. Cl.**
B21D 53/76 (2006.01)

(52) **U.S. Cl.** **29/890.1**; 347/86

(58) **Field of Classification Search** 29/890.1;
347/85, 86, 87

See application file for complete search history.

* cited by examiner

Primary Examiner—David P Bryant
Assistant Examiner—Christopher M Koehler

(57) **ABSTRACT**

A barrier film for separating liquid and air, including a liquid crystalline polymer layer having a glass transition temperature less than about 115° C., and having a thickness less than about 15 microns. The barrier film further including a heat-sealable layer, and an adhesive layer interposed between the liquid crystalline polymer layer and the heat sealable layer, forming the barrier film.

19 Claims, 2 Drawing Sheets

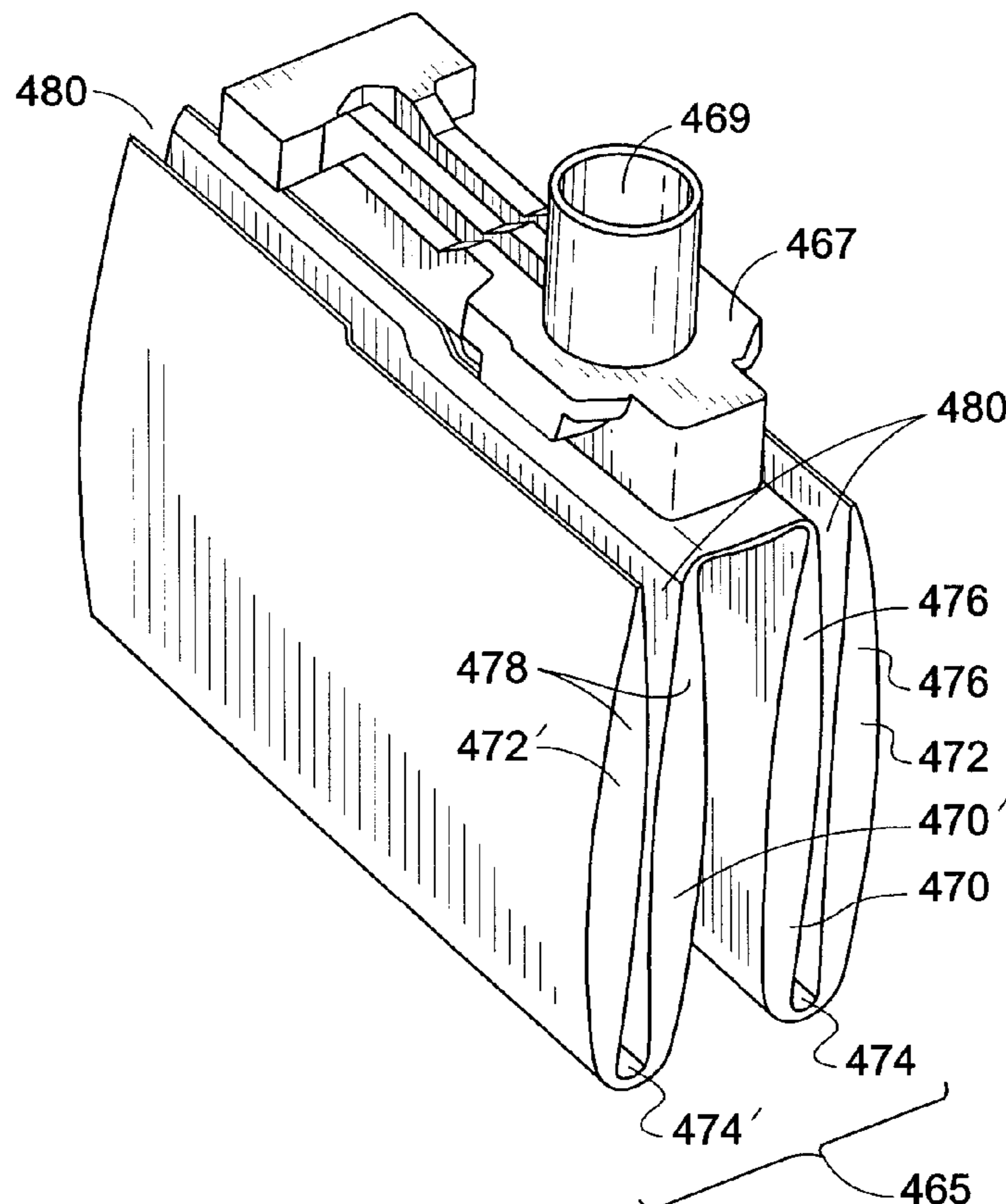

Fig. 1

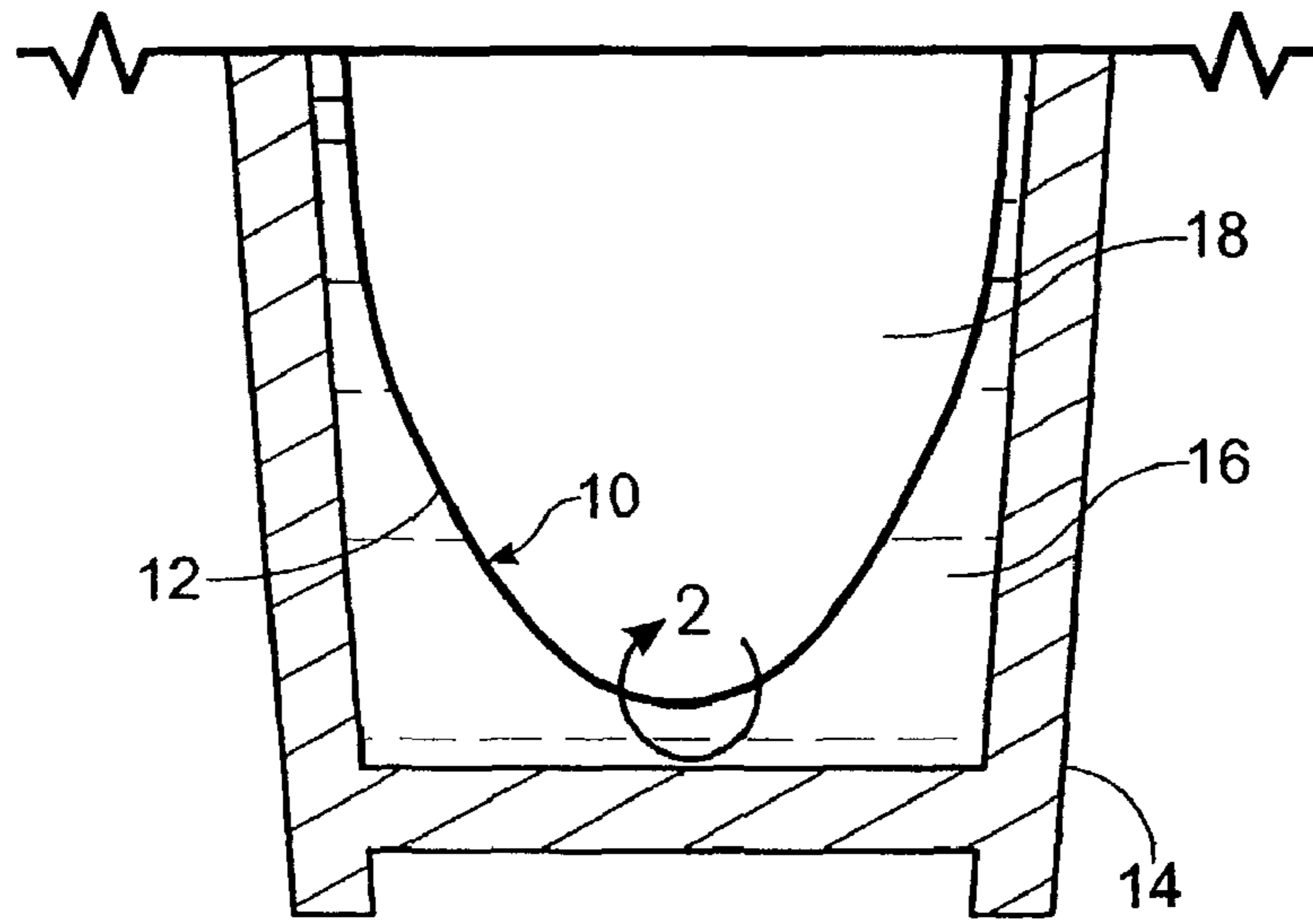

Fig. 2

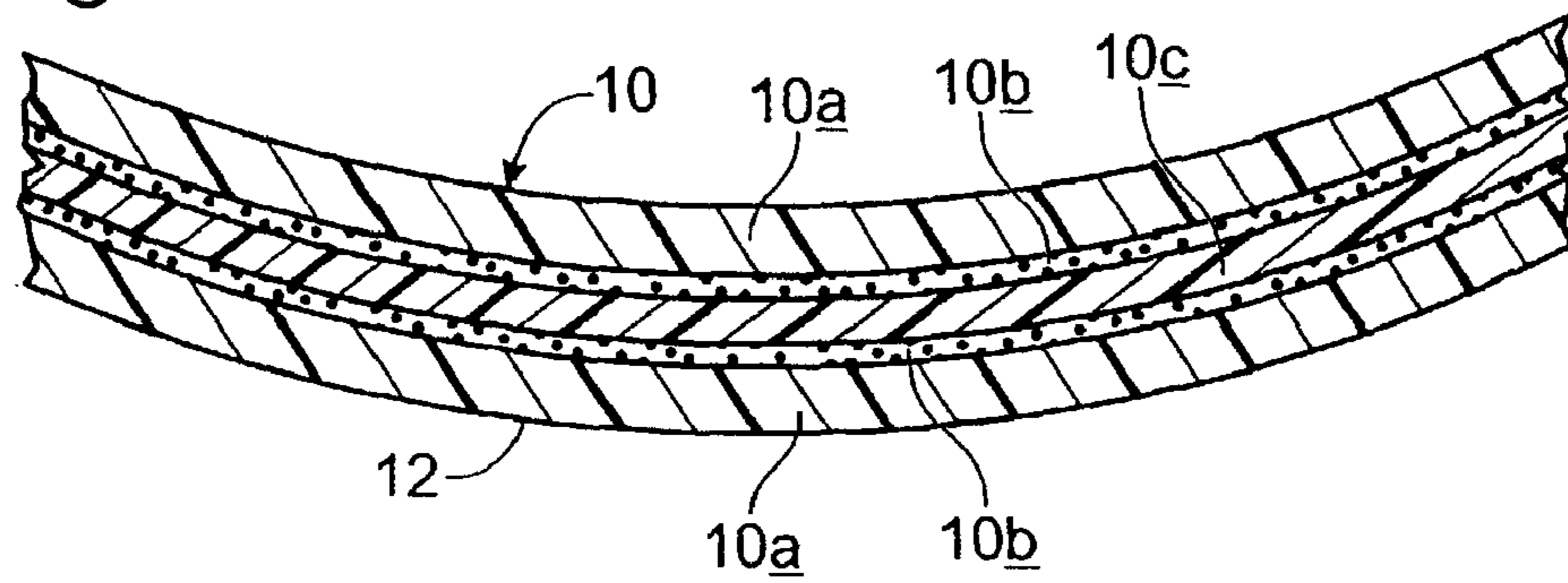
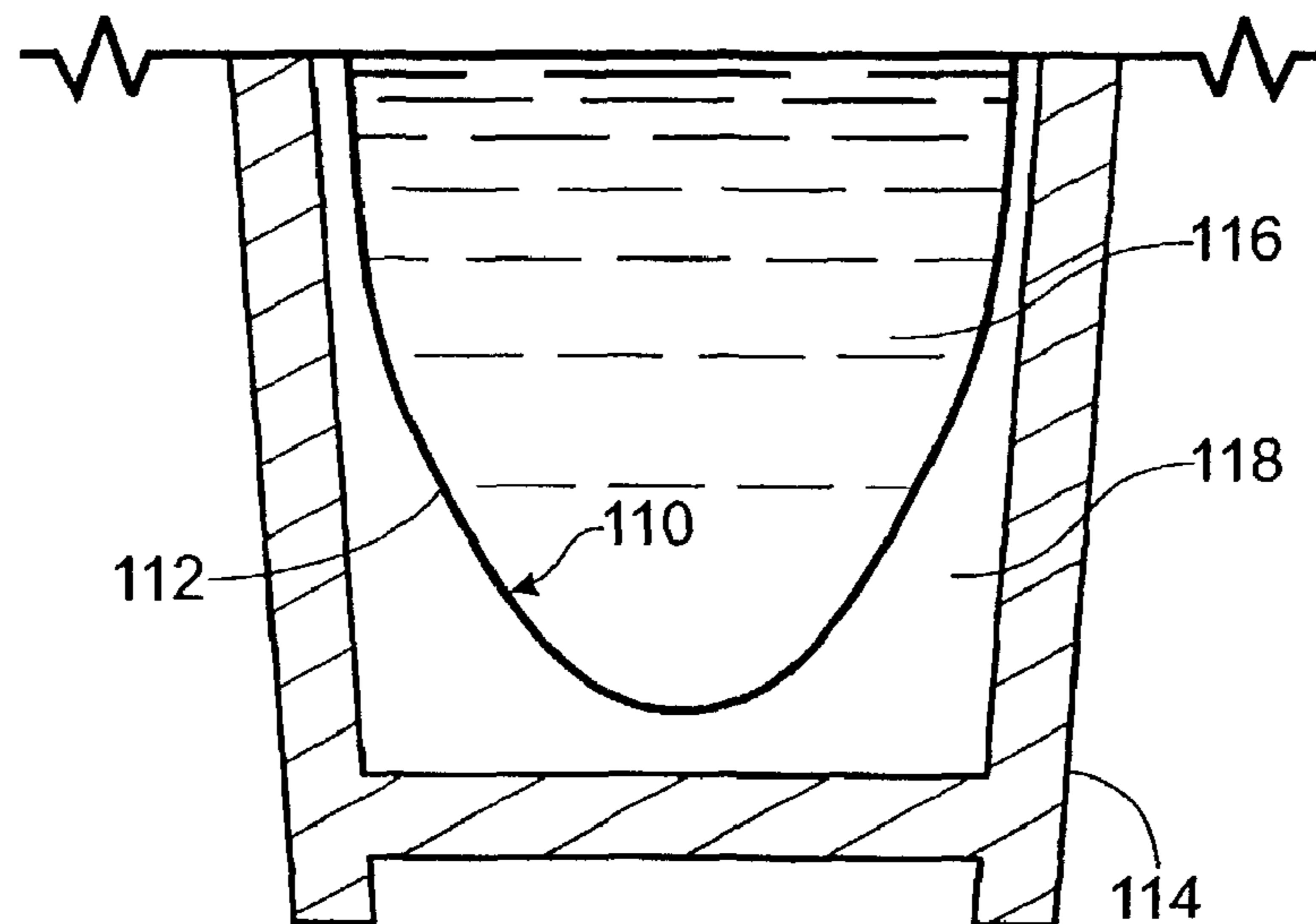

Fig. 3



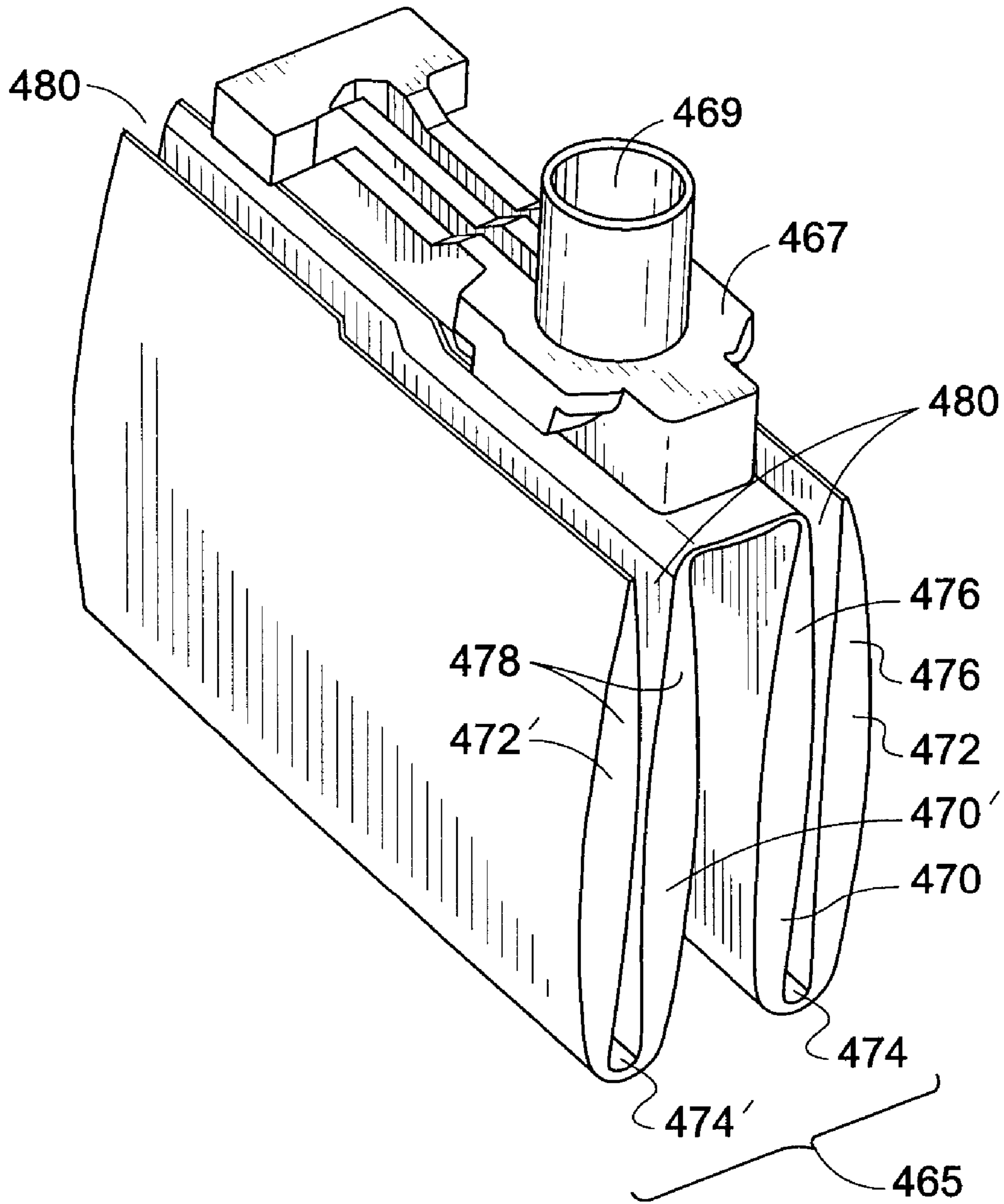

Fig. 4

FLEXIBLE BARRIER FILM STRUCTURE**CROSS REFERENCE TO RELATED APPLICATIONS**

This application is a divisional application and claims the benefit and priority of U.S. patent application Ser. No. 10/346,528 filed Jan. 17, 2003 which is a continuation in part of U.S. application Ser. No. 09/702,236, (abandoned) filed on Oct. 30, 2000, entitled Flexible Barrier Film Structure.

BACKGROUND**Description of the Art**

Ink-jet technology is employed in hard-copy-producing devices such as computer printers, graphics plotters and facsimile machines. By way of background, a description of ink-jet technology is provided in various articles in the Hewlett-Packard Journal such as those in the following editions: Vol. 36, No. 5 (May 1985), Vol. 39, No. 4 (August 1988), Vol. 39, No. 5 (October 1988), Vol. 43, No. 4 (August 1992), Vol. 43, No. 6 (December 1992) and Vol. 5, No. 1 (February 1994).

Barrier films are used in several aspects of ink-jet technology including to form: (1) bags for containing air for use in a pressure regulator such as that described in U.S. Pat. No. 5,975,686 to Hauck et al.; and (2) bags for containing ink, also referred to as ink-containment devices, such as those described in pending U.S. patent application Ser. No. 08/869,446 to Olsen et al. Both of the above-identified patent and pending patent applications are incorporated herein by reference. For ink-containment applications, the ink-containment device may be part of a disposable printer cartridge or it may be part of a so-called off-axis supply of ink.

In either of the two above-identified applications for barrier films, one of the functions of the barrier film is to provide effective separation of air and ink. In the pressure regulator application, the bag actuates the pressure regulator by expanding and contracting as a function of back pressure that exists in an ink accumulator associated with the pressure regulator and ambient pressure that is communicated through a suitable vent formed in the pressure regulator. To function, the bag must be flexible and must exhibit effective chemical stability to ink or other volatile liquid writing media. If the bag is not flexible, it will not actuate the pressure regulator.

In addition, if the bag is not stable in an ink environment, it will allow air to permeate through it. When this occurs, the bag will no longer provide for pressure regulation. To provide pressure regulation, the barrier film forming the bag must stop air from coming into the ink. If it allows air to come into the ink, then there will no longer be the desired differential pressure that prevents many unwanted events such as variations in print density and print quality, dripping of ink at the ink-jet pen nozzle, and depriming of the print cartridge.

For ink-containment devices, the barrier film must again separate air and ink to prevent the ink from drying out as it is a volatile writing medium. As a result, there is a continuing need to develop barrier films that provide desired, long term separation of air and ink so that ink-containment devices have a correspondingly long shelf life. None of the known prior art ink-containment devices provides for the secure containment of ink against the possibility of ink leakage during long-term storage, normal use or accidental shock or other trauma to the container.

There have been many conventional proposals for barrier films and those proposals have included use of the following

chemical compounds as barrier layers within a composite film: (1) PVDC (polyvinylidene chloride—a DOW version is sold under the trademark SARAN and SARANEX); (2) PVDF (polyvinylidene fluoride—a commercial version is sold under the trademark KYNAR); (3) EVOH (ethylene-vinyl alcohol copolymer); (4) metal films such as aluminum, silicon oxide or silicon dioxide; (5) ECTFE (ethylene chlorotrifluoroethylene copolymer); (6) PCTFE (polychlorotrifluoroethylene polymer); and CVD diamond-like coated films (where CVD refers to a chemical vapor deposition process).

For either the pressure-regulator or the ink-containment device application, the barrier film structure must exhibit the following characteristics: flexibility, strength, and fluid-impermeability where the fluid may be ink, other printable liquid writing media, air, or other gases.

BRIEF DESCRIPTION OF THE DRAWINGS

FIG. 1 is a fragmentary, sectional view of a pressure regulator of an fluid ejection cartridge including a flexible barrier film structure according to an embodiment of the present invention;

FIG. 2 is an enlarged, fragmentary, sectional view of the flexible barrier film structure encircled by circle-2 of FIG. 1 according to an embodiment of the present invention;

FIG. 3 is a fragmentary, sectional view of an ink containment device associated with an ink-jet printer according to an alternate embodiment of the present invention;

FIG. 4 is a perspective view of a fluid ejection cartridge regulator including a flexible barrier film structure according to an alternate embodiment of the present invention.

DESCRIPTION OF THE PREFERRED EMBODIMENTS

The flexible barrier film structure of the present invention is one for use in devices such as for example a fluid ejection cartridge to separate a fluid and air. The flexible film structure includes a film body formed of plural layers, wherein a first layer is formed as a liquid crystalline polymer (LCP), and wherein the film body exhibits a flexibility of less than about 6 grams force (gf) according to conventional film flexibility testing methods. The presently preferred use of the invention is in a five-layer flexible film as follows: heat-sealable layer/tie layer/LCP/tie layer/heat-sealable layer. The tie layer may also be thought of as an adhesive layer.

Preferably the LCP is formed with a thickness of in the range of about 5-10 microns, however in alternate embodiments a thickness less than about 15 microns may also be used. Each tie layer is formed with a thickness in the range of about 3-10 microns, and each heat-sealable layer is formed with a thickness in the range of about 5-15 microns. Suitable materials for the tie layer include a terpolymer sold under the trademark LOTADER 8900, and for the heat-sealable layer include LDPE, MDPE or HDPE (low-medium- or high-density polyethylene). Flexibility of the overall film structure is optimized by using LDPE as well as by varying the thickness of the LCP layer with thinner LCP layers providing greater flexibility.

The surprising result of the invention is that LCP, a material thought to be unacceptably stiff for the above-described barrier film applications, is actually a substantially flexible material when formed in a thickness range of less than about 15 microns and more preferably when formed in a thickness range of 5-10 microns. In general, LCP exhibits a flexural modulus about 3-5 times higher than other polymers that are candidates for use in barrier film applications. However,

according to the present invention, suitably thin LCP layers formed in multi-layer barrier film structure exhibit excellent flexibility and chemical stability to ink.

These and additional objects and advantages of the present invention will be more readily understood after consideration of the drawings and the detailed description of the preferred embodiment which follows. Referring to FIG. 1, an exemplary embodiment of the present invention is shown as part of a pressure regulator for a fluid ejection cartridge utilized as an ink-jet pen and is similar to the regulator described in U.S. Pat. No. 5,975,686 to Hauck et al. For purposes of this description, and particularly for further details of the need for back pressure in ink-jet printers, applicant also incorporates by reference the teachings of U.S. Pat. No. 5,736,992 to Pawloski, Jr.

Still referring to FIG. 1, flexible barrier film structure 10 is formed as a bag 12 which is located in a pressure regulator 14 which contains a volatile liquid writing medium such as ink 16. Bag 12 contains air 18 and functions to provide back pressure in an amount effective to prevent the above-identified undesired effects such as dripping of ink at the ink-jet pen nozzle (not shown). The presently preferred process for forming film structure 10 is by using conventional co-extrusion equipment, following the usual requirements for processing the material prior to co-extrusion. In addition, in alternate embodiments, many other processes for forming a bag made of a multi-layer film structure may also be utilized to form bag 12 from flexible barrier film structure 10; such as, for example, lamination.

Referring to FIG. 2, an enlarged section of flexible barrier film structure 10 shows that it is formed of five layers as follows: two outer layers 10a, two adhesive layers 10b that each bond one of outer layers 10a to opposite sides of a core layer 10c. Outer layers 10a are made from a heat-sealable material such as low-, medium- or high-density polyethylene (also referred to as LDPE, MDPE and HDPE, respectively). As noted above, the flexibility of flexible barrier film structure 10 may be optimized by using LDPE as well as by varying the thickness of the LCP layer with thinner LCP layers providing greater flexibility. Adhesive layers 10b may be formed of any suitable adhesive such as an adhesive marketed under the trademark LOTADER 8900 by Elf Atochem Inc.

Core layer 10c is formed of a liquid crystalline polymer such as that marketed under the name VECTRA by Ticona Inc. In this embodiment, the liquid crystalline polymer layer, forming core layer 10c, is an aromatic polyester layer having recurring monomer units derived from terephthalic acid, 6-hydroxy-2-naphthoic acid, p-hydroxybenzoic acid, 4,4'-biphenol, and resorcinol. In this embodiment, for every 100 moles of the recurring monomer units the aromatic polyester includes 30-35 moles of p-hydroxybenzoic acid units, 35-40 moles of 6-hydroxy-2-naphthoic acid units, 15 moles of terephthalic acid units, 10 moles of 4,4'-biphenol units, and 5 moles of resorcinol units. In alternate embodiments, for every 100 moles of the recurring monomer units the aromatic polyester includes 20-40 moles of p-hydroxybenzoic acid units, 10-40 moles of 6-hydroxy-2-naphthoic acid units, 15-30 moles of terephthalic acid units, 5-20 moles of 4,4'-biphenol units, and 5-20 moles of resorcinol units may also be utilized. In still other embodiments, other liquid crystalline polymers having other monomer units may also be utilized.

The liquid crystalline polymer, forming core layer 10c, has a glass transition temperature in the range from about 100° C. to about 108° C. In alternate embodiments, liquid crystalline polymer layers having a glass transition temperature in the range from about 80° C. to about 115° C. may also be utilized. In addition, the liquid crystalline polymer, forming core layer

10c, has a melt viscosity of at least 500 poise, however, in alternate embodiments a liquid crystalline polymer having a melt viscosity of at least 300 poise, at a shear rate of 1000 reciprocal seconds measured at 230° C. in a capillary rheometer using an orifice 1 mm in diameter and 30 mm long. Thus, by utilizing a core layer having a glass transition temperature in substantially the same range as either the glass transition or melting temperatures of the heat sealable and tie layers, co-extrusion may be utilized to form multi-layered film structure 10. The co-extrusion process includes combining the liquid crystalline polymer, the heat sealable polymer, and the adhesive polymer in a molten state in an extrusion die head and extruded through a slit to yield a multi-layered film. By utilizing a co-extrusion process thinner layers of each material may be utilized to form a thinner overall thickness than that obtained by conventional lamination processes.

Still referring to the multi-layer illustration in FIG. 2, preferred thicknesses and thickness ranges for each layer is as follows: (1) each outer layer 10a preferably has a thickness of about 10 microns and is within a thickness range of about 5-15 microns; (2) each adhesive layer 10b preferably has a thickness of about 5 microns and is within the thickness range of about 3-10 microns; and (3) core layer 10c preferably is about 5 microns thick and is within a thickness range of about 5-10 microns and may be less than 15 microns thick. To maintain the desired flexibility feature described below, it has been found that core layer 10c at a thickness of less than 10 microns is optimal.

Another way to characterize flexible barrier film structure 10 is to start first with core layer 10c and refer to it as a first layer. Next, adhesive layer 10b could be thought of as a second layer and outer layer 10c could be thought of as a third layer.

The presently preferred embodiment of film structure 10 is to form it as bag 12 for use in association with a pressure regulator for an ink-jet container, and to form film structure 10 in the following pattern of five layers: heat-sealable layer/adhesive layer/LCP/adhesive layer/heat-sealable layer. Preferably, each heat-sealable layer is LDPE, each adhesive layer is LOTADER 8900 adhesive, and the LCP is the one sold under the trademark VECTRA by Ticona.

Referring to FIG. 3, another embodiment of the invention is shown as flexible barrier film structure 110 formed as a bag 112 located in a container 114. Bag 112 contains ink 116 and there is air 118 in that volume of the container that is not taken up by bag 112. Except for film structure 110, the construction of bag 112 such as its configuration may be like any known ink containment bag. Likewise, container 114 may be any known associated container.

Referring to both FIGS. 1 and 3, flexible barrier film structure 10/110 effectively prevents undesired air/ink interaction. In the case of the pressure regulator application shown and described in FIG. 1, film structure 10 stops air from coming into the ink so that the desired differential pressure is maintained as described above. In the case of the ink-containment device shown in FIG. 3, film structure 110 prevents air from entering bag 112 which would cause ink 116 to dry up. In addition, if air diffuses into the ink and saturates the ink, when the ink is placed under negative pressure in an ink-containment device with a printhead, the air comes out of the saturated ink solution and becomes trapped within the ink delivery system to the printhead. Over time this accumulated trapped air displaces the ink within the ink delivery system and prevents proper pressure regulation within the printhead.

Referring again to FIG. 2, first layer/core layer 10c surprisingly provides the necessary flexibility for either application shown in FIG. 1 or 3. The LCP that forms first layer 10c

5

exhibits a flexibility of 6 gram force according to conventional film flexibility test procedures. In addition, first layer 10c provides improved chemical stability in ink or in other volatile liquid writing media. Conventional permeability testing of film structure 10/110 gave consistently low values indicating that the film structure does not degrade in an ink environment. For example, following the standard oxygen permeation testing provided by Mocon Corporation, superior barrier results were obtained for film structure 10/110 that had been soaked in ink-jet inks according to the usual test methods. Following that known testing, film structure 10/110 outperformed various conventional barrier films including ones formed with a PVDC layer using the material marketed by DOW Corporation under the trademark SARANEX 11.

Referring to FIG. 4, an alternate embodiment of a barrier film of the present invention utilized in a pressure regulator is shown in a perspective view. In this embodiment, flexible bag 465 is staked to fitment 467 that is preferably press-fit into a crown which forms the bottom portion or fluid delivery portion of an inkjet cartridge container. The crown and ink-jet cartridge container are made from a thermoplastic polymer utilizing conventional injection molding equipment. Fitment 467 includes vent 469 to ambient pressure in the shape of a helical, labyrinth path. Vent 469 connects to, and is in fluid communication with, the inside of flexible bag 465, so that flexible bag 465 is maintained at a reference pressure. The helical path reduces the diffusion of fluid out of the fluid container via diffusion through flexible bag 465. In this embodiment flexible bag 465 is formed from film body 10. Flexible bag 465 include first section 470, second section 472 and folding section 474 forming a folded structure having at least one fold. First section 470 and second section 472 are substantially parallel to each other with the three sections 470-474 forming a U shaped structure. Such a folded bag structure may be analogized to a bellows like structure. As the folded sections inflate the two sections push on each other expanding against the levers (not shown) of the regulator. In addition, as flexible bag 465 expands and contracts (i.e. inflates and deflates) the contact area to the levers remains substantially constant, providing a substantially linear response to pressure changes. Cutting a sheet of flat film, having the multi-layered structure shown in FIG. 2 and described above, to the desired size forms flexible bag 465. The flat film is staked to fitment 467 and then a hole is formed in the film that mates, or fluidically couples, with vent 469 to allow air to pass through vent 469 to the inside of flexible bag 465. The flat film is then folded in half and staked around the perimeter using heat and pressure applied to the outer edges of the film, forming first lung 476 and second lung 478. First lung 476 and second lung 478 are then folded forming a flexible folded bag as described above. In alternate embodiments corners 480 may be staked or tacked. Flexible bag 465 may then be inserted into an ink-jet cartridge container.

The invented system has broad applicability in connection with flexible barrier films for hard-copy-producing devices, and has more particular applicability to ink-jet or other fluid controlled printers which require flexible barrier films to form air bags used in association with pressure regulators and to form ink-containment devices for holding ink or other fluids in disposable printer cartridges and in off-axis supplies of ink or fluids. Air bags for use with ink-jet pressure regulators made from the flexible barrier film structure of the present invention have proven themselves reliably and securely to maintain separation from air and ink, and to exhibit the flexibility required to function as an expandable/contractible bag that actuates the pressure regulator to maintain a desired pressure differential between back pressure that exists in an

6

ink accumulator associated with the pressure regulator and ambient pressure. The invented system is inexpensively manufactured using existing tools, dies and assembly processes and equipment.

Accordingly, while the present invention has been shown and described with reference to the foregoing preferred embodiments, it will be apparent to those skilled in the art that other changes in form and detail may be made therein without departing from the spirit and scope of the invention as defined in the appended claims.

What is claimed is:

1. A method of making a flexible barrier film structure, comprising:

cutting a sheet of a flat barrier film to the desired size, said flat barrier film having a liquid crystalline polymer layer, a heat sealable layer, and an adhesive layer interposed between said liquid crystalline polymer layer and said heat sealable layer, said liquid crystalline polymer layer having a glass transition temperature in the range from about 80° C. to about 115° C., and a thickness less than about 15 microns;

staking said flat barrier film to a fitment having a vent; folding said flat barrier film substantially in half forming a folded perimeter; and

staking said flat barrier film around said folded perimeter.

2. The method in accordance with claim 1, further comprises forming a hole in said flat barrier film fluidically coupled to said vent.

3. The method in accordance with claim 1, wherein cutting said sheet of said flat barrier film further comprises cutting a flat barrier film having an aromatic polyester polymer layer.

4. The method in accordance with claim 3, wherein cutting said flat barrier film having said aromatic polyester polymer layer further comprises cutting said aromatic polyester polymer layer having recurring monomer units derived from terephthalic acid, 6-hydroxy-2-naphthoic acid, p-hydroxybenzoic acid, 4,4'-biphenol, and resorcinol.

5. The method in accordance with claim 1, further comprising:

heating said liquid crystalline polymer layer, said adhesive layer, and said heat sealable layer to a molten state in an extrusion die head;

co-extruding said liquid crystalline polymer layer, said adhesive layer, and said heat sealable layer through a slit; and

generating a multi-layered barrier film of said liquid crystalline polymer layer, said adhesive layer, and said heat sealable layer.

6. A pressure regulator including a flexible bag formed from a flexible barrier film manufactured in accordance with the method of claim 5.

7. A flexible bag formed from a flexible barrier film manufactured in accordance with the method of claim 5.

8. A pressure regulator including a flexible bag formed from a flexible barrier film manufactured in accordance with the method of claim 1.

9. A flexible bag formed from a flexible barrier film manufactured in accordance with the method of claim 1.

10. The method in accordance with claim 1, wherein said staking said flat barrier film to a fitment having a vent, said folding said flat barrier film substantially in half forming a folded perimeter, and said staking said flat barrier film around said folded perimeter comprise forming a folded flexible bag from said flat barrier film, and further comprising:

attaching said fitment to a crown; and

inserting said crown including said folded flexible bag into an ink-jet cartridge container.

7

11. A fluid ejection cartridge including a folded flexible bag manufactured in accordance with the method of claim 10.

12. The method in accordance with claim 1, wherein said liquid crystalline polymer layer has a flexibility of less than about 6 grams force.

13. The method in accordance with claim 1, wherein said liquid crystalline polymer layer has a thickness of less than about 10 microns.

14. The method in accordance with claim 1, wherein said liquid crystalline polymer layer has a glass transition temperature in the range from about 100° C. to about 108° C.

15. The method in accordance with claim 1, wherein said glass transition temperature of said liquid crystalline polymer layer is in the same range as one of a glass transition temperature and a melting temperature of said heat sealable layer and said adhesive layer.

8

16. The method in accordance with claim 1, wherein said heat sealable layer is selected from low-density, medium-density and high-density polyethylene.

17. The method in accordance with claim 1, wherein said adhesive layer is a terpolymer.

18. The method in accordance with claim 1, wherein said liquid crystalline polymer layer has a thickness in the range from about 5 microns to about 10 microns, said heat sealable layer has a thickness in the range from about 5 microns to about 15 microns, and said adhesive layer has a thickness in the range from about 3 microns to about 10 microns.

19. The method in accordance with claim 18, wherein said liquid crystalline polymer layer has a thickness of about 5 microns, said heat sealable layer has a thickness of about 10 microns, and said adhesive layer has a thickness of about 5 microns.

* * * * *

UNITED STATES PATENT AND TRADEMARK OFFICE
CERTIFICATE OF CORRECTION

PATENT NO. : 7,814,656 B2
APPLICATION NO. : 11/464797
DATED : October 19, 2010
INVENTOR(S) : Ravi Prasad

Page 1 of 1

It is certified that error appears in the above-identified patent and that said Letters Patent is hereby corrected as shown below:

In column 6, line 36, in Claim 4, delete “hyrdoxy” and insert -- hydroxy --, therefor.

Signed and Sealed this
Thirty-first Day of May, 2011

A handwritten signature in black ink that reads "David J. Kappos". The signature is written in a cursive style with a large initial 'D' and 'K'.

David J. Kappos
Director of the United States Patent and Trademark Office