



US007806910B2

(12) **United States Patent**  
**Anderson**

(10) **Patent No.:** **US 7,806,910 B2**  
(45) **Date of Patent:** **Oct. 5, 2010**

(54) **MULTI-ELEMENT BIASED SUTURE CLIP**

(75) Inventor: **Steven C. Anderson**, Mountain View, CA (US)

(73) Assignee: **Abbott Laboratories**, Abbott Park, IL (US)

(\*) Notice: Subject to any disclaimer, the term of this patent is extended or adjusted under 35 U.S.C. 154(b) by 0 days.

(21) Appl. No.: **11/461,323**

(22) Filed: **Jul. 31, 2006**

(65) **Prior Publication Data**

US 2006/0265012 A1 Nov. 23, 2006

**Related U.S. Application Data**

(63) Continuation of application No. 10/305,923, filed on Nov. 26, 2002, now Pat. No. 7,108,710.

(51) **Int. Cl.**

**A61B 17/04** (2006.01)

(52) **U.S. Cl.** ..... **606/232**; 24/132 R; 24/129 D

(58) **Field of Classification Search** ..... 606/232, 606/72, 74; 24/67.3, 132 R; 132/137, 151, 132/153, 145, 277, 279

See application file for complete search history.

(56) **References Cited**

**U.S. PATENT DOCUMENTS**

287,046 A	10/1883	Norton	
438,400 A	10/1890	Brennen	
1,088,393 A	2/1914	Backus	
1,331,401 A	2/1920	Summers	
1,426,111 A *	8/1922	Sacker	132/153

1,516,990 A *	11/1924	Silverman	132/150
1,596,004 A	8/1926	De Bengoa	
1,847,347 A *	3/1932	Maisto	132/153
2,087,074 A	7/1937	Tucker	
2,254,620 A	9/1941	Miller	
2,316,297 A	4/1943	Southerland et al.	

(Continued)

**FOREIGN PATENT DOCUMENTS**

CA 2 339 060 2/2000

(Continued)

**OTHER PUBLICATIONS**

U.S. Appl. No. 60/696,069, filed Jul. 1, 2005, Pantages et al.

(Continued)

*Primary Examiner*—Todd E Manahan

*Assistant Examiner*—Diane Yabut

(74) *Attorney, Agent, or Firm*—Workman Nydegger

(57)

**ABSTRACT**

A suture clamping system, including a plurality of elements positioned together in a row, wherein at least one of the elements is flexible, the plurality of elements each being dimensioned such that an opening slot is formed through the row of elements when the at least one flexible element is biased into a first position, and wherein a tortuous path is formed through the row of elements when the elements are not biased. A method of clamping a suture pair, including biasing a row of adjacent flexible elements to a first position in which an opening slot is formed there along; receiving the suture pair into the opening slot; and removing the biasing such that the adjacent flexible elements move to positions which hold the suture pair in a tortuous path.

**20 Claims, 14 Drawing Sheets**

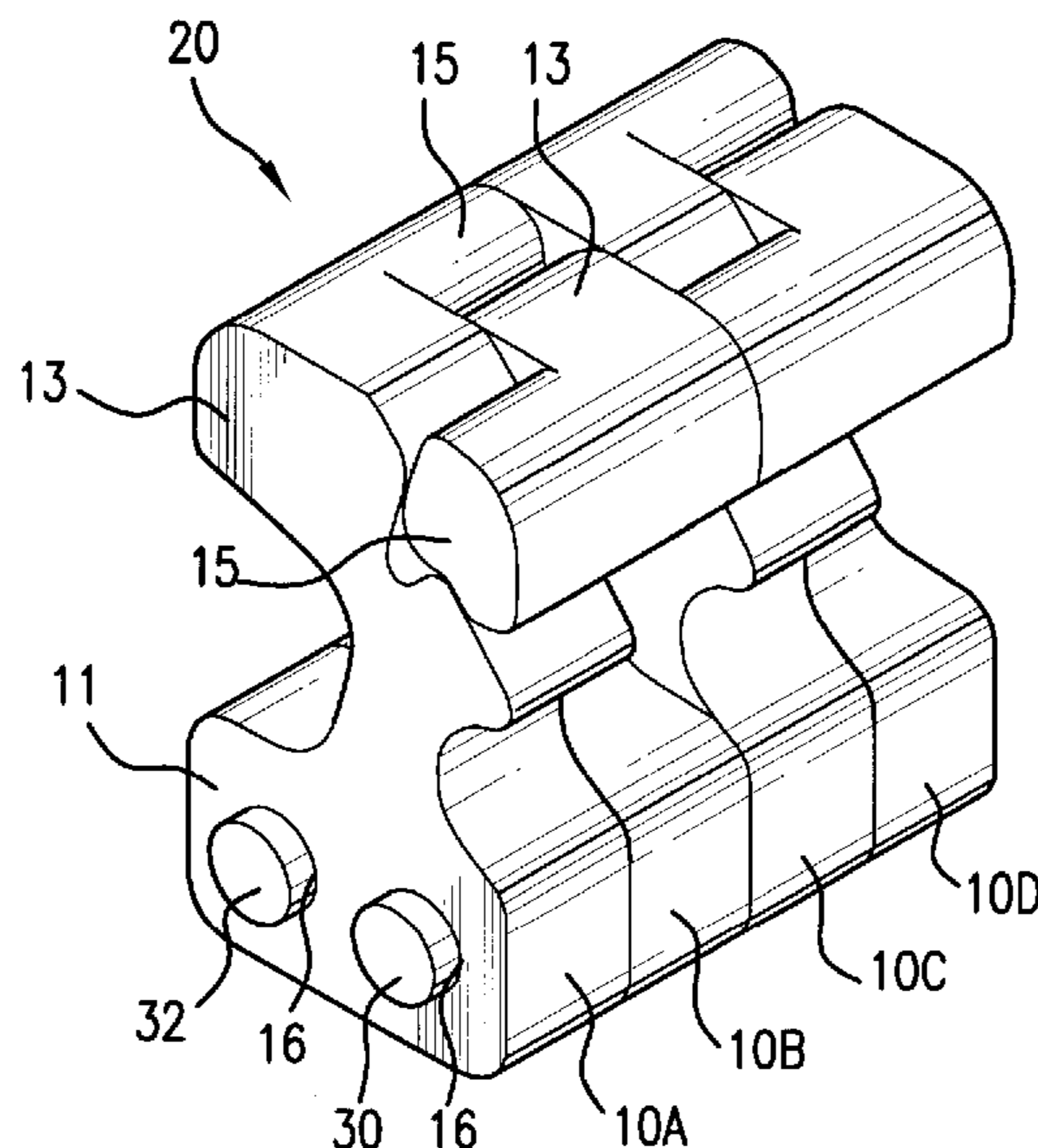

US 7,806,910 B2

U.S. PATENT DOCUMENTS					
			4,852,568 A	8/1989	Kensey
			4,860,746 A	8/1989	Yoon
			4,865,026 A	9/1989	Barrett
			4,874,122 A	10/1989	Froelich et al.
			4,878,915 A	11/1989	Brantigan
			4,887,601 A	12/1989	Richards
			4,917,087 A	4/1990	Walsh et al.
			4,929,240 A	5/1990	Kirsch et al.
			4,934,364 A	6/1990	Green
			4,950,258 A	8/1990	Kawai et al.
			4,957,499 A	9/1990	Lipatov et al.
			4,961,729 A	10/1990	Vaillancourt
			4,997,439 A	3/1991	Chen
			5,007,921 A	4/1991	Brown
			5,015,247 A	5/1991	Michelson
			5,021,059 A	6/1991	Kensey et al.
			5,026,390 A	6/1991	Brown
			5,032,127 A	7/1991	Frazer et al.
			5,047,047 A	9/1991	Yoon
			5,053,008 A	10/1991	Bajaj
			5,061,274 A	10/1991	Kensey
			5,092,941 A	3/1992	Miura
			5,100,418 A	3/1992	Yoon et al.
			5,108,420 A	4/1992	Marks
			5,108,421 A	4/1992	Fowler
			5,114,032 A	5/1992	Laidlaw
			5,114,065 A	5/1992	Storace
			5,116,349 A	5/1992	Aranyi
			5,122,156 A	6/1992	Granger et al.
			5,131,379 A	7/1992	Sewell, Jr.
			5,147,381 A	9/1992	Heimerl et al.
			5,156,609 A	10/1992	Nakao et al.
			5,167,634 A	12/1992	Corrigan, Jr. et al.
			5,167,643 A	12/1992	Lynn
			5,171,249 A	12/1992	Stefanchik et al.
			5,171,250 A	12/1992	Yoon
			5,176,648 A	1/1993	Holmes et al.
			5,192,288 A	3/1993	Thompson et al.
			5,192,300 A	3/1993	Fowler
			5,192,301 A	3/1993	Kamiya et al.
			5,192,302 A	3/1993	Kensey et al.
			5,192,602 A	3/1993	Spencer et al.
			5,209,756 A	5/1993	Seedhorm et al.
			5,217,024 A	6/1993	Dorsey et al.
			5,222,974 A	6/1993	Kensey et al.
			5,226,908 A	7/1993	Yoon
			5,236,435 A	8/1993	Sewell, Jr.
			5,242,457 A	9/1993	Akopov et al.
			5,246,156 A	9/1993	Rothfuss et al.
			5,246,443 A	9/1993	Mai
			5,250,058 A	10/1993	Miller et al.
			5,269,792 A	12/1993	Kovac et al.
			5,275,616 A	1/1994	Fowler
			5,282,808 A	2/1994	Kovac et al.
			5,290,243 A	3/1994	Chodorow et al.
			5,290,310 A	3/1994	Makower et al.
			5,292,309 A	3/1994	Van Tassel et al.
			5,292,332 A	3/1994	Lee
			5,304,184 A	4/1994	Hathaway et al.
			5,306,254 A	4/1994	Nash et al.
			5,318,542 A	6/1994	Hirsch et al.
			5,320,639 A	6/1994	Rudnick
			5,330,442 A *	7/1994	Green et al. .... 606/232
			5,334,216 A	8/1994	Vidal et al.
			5,334,217 A	8/1994	Das
			5,335,680 A	8/1994	Moore
			5,340,360 A	8/1994	Stefanchik
			5,350,399 A	9/1994	Erlebacher et al.
			5,352,229 A	10/1994	Goble et al.
			5,364,406 A	11/1994	Sewell, Jr.
			5,364,408 A	11/1994	Gordon
			5,366,458 A	11/1994	Korthoff et al.
			5,366,479 A	11/1994	McGarry et al.
2,453,227 A	11/1948	James			
2,583,625 A	1/1952	Bergan			
2,684,070 A	7/1954	Kelsey			
2,910,067 A	10/1959	White			
2,944,311 A	7/1960	Schneckenberger			
2,951,482 A	9/1960	Sullivan			
2,969,887 A	1/1961	Darmstadt et al.			
3,015,403 A	1/1962	Fuller			
3,113,379 A	12/1963	Frank			
3,120,230 A	2/1964	Skold			
3,142,878 A	8/1964	Santora			
3,209,754 A	10/1965	Brown			
3,482,428 A	12/1969	Kapitanov et al.			
3,494,533 A	2/1970	Green et al.			
3,523,351 A	8/1970	Filia			
3,586,002 A	6/1971	Wood			
3,604,425 A	9/1971	Le Roy			
3,677,243 A	7/1972	Nerz			
3,757,629 A	9/1973	Schneider			
3,805,337 A	4/1974	Branstetter			
3,828,791 A	8/1974	Santos			
3,856,016 A	12/1974	Davis			
3,908,662 A	9/1975	Razgulov et al.			
3,944,114 A	3/1976	Coppens			
4,014,492 A	3/1977	Rothfuss			
4,064,881 A	12/1977	Meredith			
4,162,673 A	7/1979	Patel			
4,169,476 A	10/1979	Hiltebrandt			
4,192,315 A	3/1980	Hilzinger et al.			
4,201,215 A	5/1980	Crossett et al.			
4,204,541 A	5/1980	Kapitanov			
4,207,870 A	6/1980	Eldridge			
4,215,699 A	8/1980	Patel			
4,217,902 A	8/1980	March			
4,278,091 A	7/1981	Borzzone			
4,317,445 A	3/1982	Robinson			
4,318,401 A	3/1982	Zimmerman			
4,327,485 A	5/1982	Rix			
4,345,606 A	8/1982	Littleford			
4,368,736 A	1/1983	Kaster			
4,387,489 A *	6/1983	Dudek ..... 24/133			
4,396,139 A	8/1983	Hall et al.			
4,400,879 A *	8/1983	Hildreth ..... 132/151			
4,411,654 A	10/1983	Boarini et al.			
4,412,832 A	11/1983	Kling et al.			
4,428,376 A	1/1984	Mericle			
4,440,170 A	4/1984	Golden et al.			
4,485,816 A	12/1984	Krumme			
RE31,855 E	3/1985	Osborne			
4,505,273 A	3/1985	Braun et al.			
4,523,695 A	6/1985	Braun et al.			
4,525,157 A	6/1985	Valaincourt			
4,526,174 A	7/1985	Froehlich			
4,586,503 A	5/1986	Kirsch et al.			
4,607,638 A	8/1986	Crainich			
4,610,251 A	9/1986	Kumar			
4,610,252 A	9/1986	Catalano			
4,635,634 A	1/1987	Santos			
4,665,906 A	5/1987	Jervis			
4,687,469 A	8/1987	Osypka			
4,724,840 A	2/1988	McVay et al.			
4,738,658 A	4/1988	Magro et al.			
4,744,364 A	5/1988	Kensey			
4,747,407 A	5/1988	Liu et al.			
4,759,364 A	7/1988	Boebel			
4,771,782 A	9/1988	Millar			
4,772,266 A	9/1988	Groshong			
4,777,950 A	10/1988	Kees, Jr.			
4,789,090 A	12/1988	Blake, III			
4,832,688 A	5/1989	Sagae et al.			
4,836,204 A	6/1989	Landymore et al.			

# US 7,806,910 B2

5,383,896 A	1/1995	Gershony et al.	5,795,958 A	8/1998	Rao et al.
RE34,866 E	2/1995	Kensey et al.	5,797,931 A	8/1998	Bito et al.
5,392,978 A	2/1995	Velez	5,797,933 A	8/1998	Snow et al.
5,395,030 A	3/1995	Kuramoto et al.	5,797,958 A	8/1998	Yoon
5,411,520 A	5/1995	Nash et al.	5,810,776 A	9/1998	Bacich et al.
5,413,571 A	5/1995	Katsaros et al.	5,810,846 A	9/1998	Virnich et al.
5,413,584 A	5/1995	Schulze	5,810,851 A	9/1998	Yoon
5,416,584 A	5/1995	Kay	5,817,113 A	10/1998	Gifford, III et al.
5,417,699 A	5/1995	Klein et al.	5,820,631 A	10/1998	Nobles
5,419,777 A	5/1995	Hofling	5,827,298 A	10/1998	Hart et al.
5,423,857 A	6/1995	Rosenman et al.	5,830,125 A	11/1998	Scribner et al.
5,425,489 A	6/1995	Shichman et al.	5,833,698 A	11/1998	Hinchliffe et al.
5,431,639 A	7/1995	Shaw	5,853,421 A	12/1998	Leschinsky et al.
5,431,667 A	7/1995	Thompson et al.	5,853,422 A	12/1998	Huebsch et al.
5,437,631 A	8/1995	Janzen	5,855,312 A	1/1999	Toledano
5,443,481 A	8/1995	Lee	5,858,082 A	1/1999	Cruz et al.
5,449,359 A	9/1995	Groiso	5,860,991 A	1/1999	Klein et al.
5,456,400 A	10/1995	Shichman et al.	5,861,005 A	1/1999	Kontos
5,462,561 A	10/1995	Voda	5,868,755 A	2/1999	Kanner et al.
5,470,010 A	11/1995	Rothfuss et al.	5,871,474 A	2/1999	Hermann et al.
5,474,557 A	12/1995	Mai	5,871,501 A	2/1999	Leschinsky et al.
5,478,352 A	12/1995	Fowler	5,871,525 A	2/1999	Edwards et al.
5,478,353 A	12/1995	Yoon	5,879,366 A	3/1999	Shaw et al.
5,478,354 A	12/1995	Tovey et al.	5,902,310 A	5/1999	Foerster et al.
5,486,195 A	1/1996	Myers et al.	5,904,697 A	5/1999	Gifford, III et al.
5,497,933 A	3/1996	DeFonzo et al.	5,907,893 A	6/1999	Zadno-Azizi et al.
5,507,744 A	4/1996	Tay et al.	5,910,155 A	6/1999	Ratcliff et al.
5,507,755 A	4/1996	Gresl et al.	5,922,009 A	7/1999	Epstein et al.
5,522,840 A	6/1996	Krajicek	5,935,147 A	8/1999	Kensey et al.
5,527,322 A	6/1996	Klein et al.	5,938,667 A	8/1999	Peyser et al.
5,536,251 A	7/1996	Evard et al.	5,941,890 A	8/1999	Voegele et al.
5,540,712 A	7/1996	Kleshinski et al.	5,947,999 A	9/1999	Groiso
5,540,716 A	7/1996	Hlavacek	5,951,518 A	9/1999	Licata et al.
5,544,802 A	8/1996	Crainich	5,951,576 A	9/1999	Wakabayashi
5,547,474 A	8/1996	Kloeckl et al.	5,951,589 A	9/1999	Epstein et al.
5,560,532 A	10/1996	DeFonzo et al.	5,964,782 A	10/1999	Lafontaine et al.
5,575,771 A	11/1996	Walinsky	5,984,934 A	11/1999	Ashby et al.
5,584,879 A	12/1996	Reimold et al.	5,984,949 A	11/1999	Levin
5,591,205 A	1/1997	Fowler	5,993,468 A	11/1999	Rygaard
5,593,412 A	1/1997	Martinez et al.	5,993,476 A	11/1999	Groiso
5,601,602 A	2/1997	Fowler	6,001,110 A	12/1999	Adams
5,618,291 A	4/1997	Thompson et al.	6,004,341 A	12/1999	Zhu et al.
5,620,452 A	4/1997	Yoon	6,007,563 A	12/1999	Nash et al.
5,620,461 A	4/1997	Muijs Van De Moer et al.	6,022,372 A	2/2000	Kontos
5,643,318 A	7/1997	Tsukernik et al.	6,024,750 A	2/2000	Mastri
5,645,565 A	7/1997	Rudd et al.	6,030,364 A	2/2000	Durgin et al.
5,645,566 A	7/1997	Brenneman et al.	6,030,413 A	2/2000	Lazarus
5,645,567 A	7/1997	Crainich	6,033,427 A	3/2000	Lee
D383,539 S	9/1997	Croley	6,036,703 A	3/2000	Evans et al.
5,674,231 A	10/1997	Green et al.	6,036,720 A	3/2000	Abrams et al.
5,676,689 A	10/1997	Kensey et al.	6,045,570 A	4/2000	Epstein et al.
5,676,974 A	10/1997	Valdes et al.	6,048,358 A	4/2000	Barak
5,683,405 A	11/1997	Yacoubian et al.	6,056,768 A	5/2000	Cates et al.
5,690,674 A	11/1997	Diaz	6,056,769 A	5/2000	Epstein et al.
5,695,504 A	12/1997	Gifford, III et al.	6,056,770 A	5/2000	Epstein et al.
5,695,505 A	12/1997	Yoon	6,059,800 A	5/2000	Hart et al.
5,695,524 A	12/1997	Kelley et al.	6,063,085 A	5/2000	Tay et al.
5,700,273 A	12/1997	Buelna et al.	6,077,281 A	6/2000	Das
5,716,375 A	2/1998	Fowler	6,077,291 A	6/2000	Das
5,720,755 A	2/1998	Dakov	6,080,182 A	6/2000	Shaw et al.
5,725,554 A	3/1998	Simon et al.	6,080,183 A	6/2000	Tsugita et al.
5,728,114 A	3/1998	Evans et al.	6,090,130 A	7/2000	Nash et al.
5,728,122 A	3/1998	Leschinsky et al.	6,099,553 A *	8/2000	Hart et al. .... 606/232
5,728,132 A	3/1998	Van Tassel et al.	6,102,271 A	8/2000	Longo et al.
5,732,872 A	3/1998	Bolduc et al.	6,110,184 A	8/2000	Weadock
5,752,966 A	5/1998	Chang	6,113,612 A	9/2000	Swanson et al.
5,755,778 A	5/1998	Kleshinski	6,117,125 A	9/2000	Rothbarth et al.
5,766,246 A	6/1998	Mulhauser et al.	6,117,148 A	9/2000	Ravo
5,769,870 A	6/1998	Salahieh et al.	6,120,524 A	9/2000	Taheri
5,779,707 A	7/1998	Bertholet et al.	6,149,660 A	11/2000	Laufer et al.
5,782,844 A	7/1998	Yoon et al.	6,149,667 A	11/2000	Hovland et al.
5,782,860 A	7/1998	Epstein et al.	6,152,144 A	11/2000	Lesh et al.
5,782,861 A	7/1998	Cragg et al.	6,152,937 A	11/2000	Peterson et al.

# US 7,806,910 B2

6,193,734	B1	2/2001	Bolduc et al.	2001/0007077	A1	7/2001	Ginn et al.
6,197,042	B1	3/2001	Ginn et al.	2001/0031972	A1	10/2001	Robertson et al.
6,206,913	B1	3/2001	Yencho et al.	2001/0047180	A1	11/2001	Grudem et al.
6,220,248	B1	4/2001	Voegele et al.	2002/0026215	A1	2/2002	Redmond et al.
6,221,102	B1	4/2001	Baker et al.	2002/0042622	A1	4/2002	Vargas et al.
6,254,642	B1	7/2001	Taylor	2002/0049427	A1	4/2002	Wiener et al.
6,277,140	B2	8/2001	Ginn et al.	2002/0049472	A1	4/2002	Coleman et al.
6,280,460	B1	8/2001	Bolduc et al.	2002/0058960	A1	5/2002	Hudson et al.
6,287,322	B1	9/2001	Zhu et al.	2002/0072768	A1	6/2002	Ginn
6,305,891	B1	10/2001	Burlingame	2002/0077657	A1	6/2002	Ginn et al.
6,322,580	B1	11/2001	Kanner	2002/0082641	A1	6/2002	Ginn et al.
6,334,865	B1	1/2002	Redmond et al.	2002/0107542	A1	8/2002	Kanner et al.
6,348,064	B1	2/2002	Kanner	2002/0133193	A1	9/2002	Ginn et al.
D457,958	S	5/2002	Dycus	2002/0151921	A1	10/2002	Kanner et al.
6,383,208	B1	5/2002	Sancoff et al.	2002/0193808	A1	12/2002	Belef et al.
6,391,048	B1	5/2002	Ginn et al.	2003/0004543	A1	1/2003	Gleeson et al.
6,398,752	B1	6/2002	Sweezer et al.	2003/0009180	A1	1/2003	Hinchliffe et al.
6,402,765	B1	6/2002	Monassevitch et al.	2003/0032981	A1	2/2003	Kanner et al.
6,409,739	B1	6/2002	Nobles et al.	2003/0065358	A1	4/2003	Frecker et al.
6,419,669	B1	7/2002	Frazier et al.	2003/0078598	A1	4/2003	Ginn et al.
6,428,548	B1	8/2002	Durgin et al.	2003/0083679	A1	5/2003	Grudem et al.
6,443,158	B1	9/2002	Lafontaine et al.	2003/0093096	A1	5/2003	McGuckin et al.
6,450,391	B1	9/2002	Kayan et al.	2003/0097140	A1	5/2003	Kanner
6,458,130	B1	10/2002	Frazier et al.	2003/0109890	A1	6/2003	Kanner et al.
6,461,364	B1	10/2002	Ginn et al.	2003/0125766	A1	7/2003	Ding
6,488,692	B1	12/2002	Spence et al.	2003/0158577	A1	8/2003	Pantages et al.
6,500,115	B2	12/2002	Krattiger et al.	2003/0158578	A1	8/2003	Pantages et al.
6,506,210	B1	1/2003	Kanner	2003/0195504	A1	10/2003	Tallarida et al.
6,517,569	B2	2/2003	Mikus et al.	2003/0195561	A1	10/2003	Carley et al.
6,533,762	B2	3/2003	Kanner et al.	2004/0009289	A1	1/2004	Carley et al.
6,537,288	B2	3/2003	Vargas et al.	2004/0010285	A1	1/2004	Carley et al.
6,547,806	B1	4/2003	Ding	2004/0039414	A1	2/2004	Carley et al.
6,569,173	B1	5/2003	Blatter et al.	2004/0073236	A1	4/2004	Carley et al.
6,582,452	B2	6/2003	Coleman et al.	2004/0073255	A1	4/2004	Ginn et al.
6,599,303	B1	7/2003	Peterson et al.	2004/0082906	A1	4/2004	Tallarida et al.
6,602,263	B1	8/2003	Swanson et al.	2004/0087985	A1	5/2004	Loshakove et al.
6,616,686	B2	9/2003	Coleman et al.	2004/0092968	A1	5/2004	Caro et al.
6,623,510	B2	9/2003	Carley et al.	2004/0153122	A1	8/2004	Palermo
6,626,918	B1	9/2003	Ginn et al.	2004/0153123	A1	8/2004	Palermo et al.
6,632,238	B2	10/2003	Ginn et al.	2004/0167570	A1	8/2004	Pantages
6,634,537	B2	10/2003	Chen	2004/0254591	A1	12/2004	Kanner et al.
6,645,205	B2	11/2003	Ginn	2004/0267312	A1	12/2004	Kanner et al.
6,652,538	B2	11/2003	Kayan et al.	2005/0090859	A1	4/2005	Ravlkumar
6,669,714	B2	12/2003	Coleman et al.	2005/0119695	A1	6/2005	Carley et al.
6,676,671	B2	1/2004	Robertson et al.	2005/0165357	A1	7/2005	McGuckin et al.
6,679,904	B2	1/2004	Gleeson et al.	2005/0216057	A1	9/2005	Coleman et al.
6,695,867	B2	2/2004	Ginn et al.	2005/0234508	A1	10/2005	Cummins et al.
6,699,256	B1	3/2004	Logan et al.	2005/0267530	A1	12/2005	Cummins et al.
6,702,826	B2	3/2004	Liddicoat et al.	2005/0273136	A1	12/2005	Belef et al.
6,712,836	B1	3/2004	Berg et al.	2005/0274768	A1	12/2005	Cummins et al.
6,719,777	B2	4/2004	Ginn et al.	2005/0283188	A1	12/2005	Loshakove et al.
6,726,704	B1	4/2004	Loshakove et al.	2006/0020270	A1	1/2006	Jabba et al.
6,749,621	B2	6/2004	Pantages et al.	2006/0135989	A1	6/2006	Carley et al.
6,749,622	B2	6/2004	McGuckin et al.	2006/0144479	A1	7/2006	Carley et al.
6,755,842	B2	6/2004	Kanner et al.	2006/0167484	A1	7/2006	Carley et al.
6,767,356	B2	7/2004	Kanner et al.	2006/0190014	A1	8/2006	Ginn et al.
6,780,197	B2	8/2004	Roe et al.	2006/0190038	A1	8/2006	Carley et al.
6,846,319	B2	1/2005	Ginn et al.	2006/0195123	A1	8/2006	Ginn et al.
6,896,687	B2	5/2005	Dakov	2006/0195124	A1	8/2006	Ginn et al.
6,926,723	B1	8/2005	Mulhauser et al.	2006/0287674	A1	12/2006	Ginn et al.
6,926,731	B2	8/2005	Coleman et al.	2007/0010853	A1	1/2007	Ginn et al.
6,942,674	B2	9/2005	Belef et al.	2007/0010854	A1	1/2007	Cummins et al.
6,989,003	B2	1/2006	Wing et al.	2007/0270904	A1	11/2007	Ginn
6,989,016	B2	1/2006	Tallarida et al.	2007/0276416	A1	11/2007	Ginn et al.
7,001,398	B2	2/2006	Carley et al.	2007/0282352	A1	12/2007	Carley et al.
7,108,709	B2	9/2006	Cummins	2008/0004636	A1	1/2008	Walberg
7,111,768	B2	9/2006	Cummins et al.	2008/0065152	A1	3/2008	Carley
7,144,411	B2	12/2006	Ginn et al.	2008/0210737	A1	9/2008	Ginn et al.
7,163,551	B2	1/2007	Anthony et al.	2008/0221616	A1	9/2008	Ginn et al.
7,169,158	B2	1/2007	Sniffin et al.	2008/0269801	A1	10/2008	Coleman et al.
7,211,101	B2	5/2007	Carley et al.	2008/0269802	A1	10/2008	Coleman et al.
D566,272	S	4/2008	Walberg et al.	2008/0272173	A1	11/2008	Coleman et al.
7,396,359	B1	7/2008	Derowe et al.	2008/0312666	A1	12/2008	Ellingwood et al.

2008/0312686 A1 12/2008 Ellingwood

## FOREIGN PATENT DOCUMENTS

DE	197 11 288	10/1998
DE	29723736 U1	4/1999
DE	19859952	2/2000
EP	0 386 361	9/1990
EP	0 534 696	3/1993
EP	0 756 851	2/1997
EP	0 774 237	5/1997
EP	0 858 776	8/1998
EP	0 941 697	9/1999
FR	2 443 238	7/1980
FR	2 715 290	7/1995
FR	2 722 975	2/1996
GB	1 358 466	7/1974
GB	2 075 144	11/1981
IE	S2000/0722	10/2001
IE	S2000/0724	10/2001
IE	S2001/0547	7/2002
IE	S2001/0815	7/2002
IE	S2001/0748	8/2002
IE	S2001/0749	8/2002
IE	S2002/0452	12/2002
IE	S2002/0664	2/2003
IE	S2002/0665	2/2003
IE	S2002/0451	7/2003
IE	S2002/0552	7/2003
IE	S2003/0424	12/2003
IE	S2003/0490	1/2004
IE	S2004/0368	11/2005
IE	S2005/0342	11/2005
JP	12 74750	11/1989
JP	11500642	8/1997
NL	9302140	7/1995
PL	171425	4/1997
RU	2086192	8/1997
SU	495067	12/1975
SU	912155	3/1982
SU	1243708	7/1986
SU	1324650	7/1987
SU	1405828	6/1988
SU	1456109	2/1989
SU	1560133	4/1990
WO	WO 96/24291	8/1996
WO	WO 97/07741	3/1997
WO	WO 97/20505	6/1997
WO	WO 97/27897	8/1997
WO	WO 98/06346	2/1998
WO	WO 98/06448	2/1998
WO	WO 98/16161	4/1998
WO	WO 98/17179	4/1998
WO	WO 98/18389	5/1998
WO	WO 98/24374	6/1998
WO	WO 98/25508	6/1998
WO	WO 98/58591	12/1998
WO	WO 99/21491	5/1999
WO	WO 99/60941	12/1999
WO	WO 99/62408	12/1999
WO	WO 99/62415	12/1999
WO	WO 00/06029	2/2000
WO	WO 00/07640	2/2000
WO	WO 00/56223	9/2000
WO	WO 00/56227	9/2000
WO	WO 00/56228	9/2000
WO	WO 00/71032	11/2000
WO	WO 01/21058	3/2001
WO	WO 01/35832	5/2001
WO	WO 01/47594	7/2001
WO	WO 01/49186	7/2001
WO	WO 01/91628	12/2001
WO	WO 02/19915	3/2002

WO	WO 02/19920	3/2002
WO	WO 02/19922	3/2002
WO	WO 02/19924	3/2002
WO	WO 02/28286	4/2002
WO	WO 02/45593	6/2002
WO	WO 02/45594	6/2002
WO	WO 02/98302	12/2002
WO	WO 03/013363	2/2003
WO	WO 03/013364	2/2003
WO	WO 03/047434	6/2003
WO	WO 03/071955	9/2003
WO	WO 03/071956	9/2003
WO	WO 03/071957	9/2003
WO	WO 03/101310	12/2003
WO	WO 2004/004578	1/2004
WO	WO 2004/060169	7/2004
WO	WO 2004/069054	8/2004
WO	WO 2005/082256	9/2005
WO	WO 2005/115521	12/2005
WO	WO 2006/083889	8/2006
WO	WO 2007/005585	1/2007
WO	WO 2008/031102	3/2008
ZA	200100527	1/2001

## OTHER PUBLICATIONS

U.S. Appl. No. 60/946,026, filed Jun. 25, 2007, Ellingwood.  
U.S. Appl. No. 12/393,877, filed Feb. 26, 2009, Ellingwood et al.  
U.S. Appl. No. 12/402,398, filed Mar. 11, 2009, Carley et al.  
U.S. Appl. No. 12/403,256, filed Mar. 12, 2009, Carley et al.  
U.S. Appl. No. 12/403,277, filed Mar. 12, 2009, Coleman et al.  
U.S. Appl. No. 09/680,837, Mail Date Jul. 9, 2002, Office Action.  
U.S. Appl. No. 09/680,837, Mail Date Nov. 6, 2002, Office Action.  
U.S. Appl. No. 09/680,837, Mail Date Mar. 25, 2003, Office Action.  
U.S. Appl. No. 09/680,837, Mail Date Jun. 16, 2003, Notice Of Allowance.  
U.S. Appl. No. 09/680,837, Mail Date Sep. 11, 2003, Issue Notification.  
U.S. Appl. No. 10/006,400, Mail Date Jan. 2, 2009, Office Action.  
U.S. Appl. No. 10/147,774, Mail Date Mar. 18, 2009, Office Action.  
U.S. Appl. No. 10/264,306, Mail Date Feb. 26, 2009, Office Action.  
U.S. Appl. No. 10/356,214, Mail Date Nov. 4, 2008, Office Action.  
U.S. Appl. No. 10/356,214, Mail Date Apr. 29, 2009, Office Action.  
U.S. Appl. No. 10/435,104, Mail Date Nov. 14, 2007, Notice Of Allowance.  
U.S. Appl. No. 10/435,104, Mail Date Dec. 22, 2008, Notice Of Allowance.  
U.S. Appl. No. 10/517,004, Mail Date Aug. 13, 2008, Notice Of Allowance.  
U.S. Appl. No. 10/517,004, Mail Date Feb. 10, 2009, Notice Of Allowance.  
U.S. Appl. No. 10/541,083, Mail Date Oct. 31, 2007, Office Action.  
U.S. Appl. No. 10/541,083, Mail Date Dec. 29, 2008, Notice Of Allowance.  
U.S. Appl. No. 10/638,115, Mail Date Oct. 29, 2008, Office Action.  
U.S. Appl. No. 10/667,144, Mail Date Mar. 24, 2009, Office Action.  
U.S. Appl. No. 10/669,313, Mail Date Oct. 31, 2005, Office Action.  
U.S. Appl. No. 10/669,313, Mail Date Jan. 11, 2006, Notice Of Allowance.  
U.S. Appl. No. 10/669,313, Mail Date Jun. 28, 2006, Notice Of Allowance.  
U.S. Appl. No. 10/669,313, Mail Date Nov. 15, 2006, Issue Notification.  
U.S. Appl. No. 10/682,459, Mail Date Dec. 4, 2008, Office Action.  
U.S. Appl. No. 10/787,073, Mail Date Nov. 12, 2008, Office Action.  
U.S. Appl. No. 10/908,721, Mail Date Nov. 25, 2008, Office Action.  
U.S. Appl. No. 11/048,503, Mail Date Mar. 13, 2009, Office Action.  
U.S. Appl. No. 11/152,562, Mail Date Feb. 13, 2009, Office Action.  
U.S. Appl. No. 11/344,793, Mail Date Jan. 22, 2009, Office Action.  
U.S. Appl. No. 11/344,868, Mail Date Mar. 25, 2009, Office Action.  
U.S. Appl. No. 11/344,891, Mail Date Dec. 8, 2008, Office Action.  
U.S. Appl. No. 11/344,891, Mail Date Feb. 26, 2009, Office Action.  
U.S. Appl. No. 11/396,731, Mail Date Feb. 13, 2009, Office Action.

- U.S. Appl. No. 11/406,203, Mail Date Mar. 3, 2009, Office Action.  
U.S. Appl. No. 11/427,297, Mail Date Jan. 30, 2009, Office Action.  
U.S. Appl. No. 11/532,325, Mail Date Feb. 23, 2009, Office Action.  
U.S. Appl. No. 11/744,089, Mail Date Nov. 26, 2008, Office Action.  
U.S. Appl. No. 12/106,928, Mail Date Jan. 23, 2009, Office Action.  
U.S. Appl. No. 12/106,937, Mail Date Mar. 30, 2009, Office Action.  
U.S. Appl. No. 29/296,370, Mail Date Aug. 18, 2008, Office Action.  
U.S. Appl. No. 29/296,370, Mail Date Dec. 2, 2008, Notice Of Allowance.  
U.S. Appl. No. 29,296,370, Mail Date Apr. 1, 2009, Notice Of Allowance.  
U.S. Appl. No. 09/478,179, Mail Date Nov. 6, 2000, Notice of Allowance.  
U.S. Appl. No. 09/478,179, Mail Date Feb. 15, 2001, Issue Notification.  
U.S. Appl. No. 09/546,998, Mail Date May 6, 2002, Notice of Allowance.  
U.S. Appl. No. 09/546,998, Mail Date Sep. 19, 2002, Issue Notification.  
U.S. Appl. No. 09/610,238, Mail Date Mar. 26, 2001, Notice of Allowance.  
U.S. Appl. No. 09/610,238, Mail Date Sep. 5, 2001, Office Action.  
U.S. Appl. No. 09/610,238, Mail Date Feb. 11, 2002, Notice of Allowance.  
U.S. Appl. No. 09/610,238, Mail Date May 3, 2002, Issue Notification.  
U.S. Appl. No. 09/732,178, Mail Date Aug. 1, 2002, Office Action.  
U.S. Appl. No. 09/732,178, Mail Date Dec. 24, 2002, Office Action.  
U.S. Appl. No. 09/732,178, Mail Date Jun. 10, 2003, Office Action.  
U.S. Appl. No. 09/732,178, Mail Date Jul. 3, 2003, Office Action.  
U.S. Appl. No. 09/732,178, Mail Date Nov. 17, 2003, Notice of Allowance.  
U.S. Appl. No. 09/732,178, Mail Date Mar. 25, 2004, Issue Notification.  
U.S. Appl. No. 09/732,835, Mail Date Sep. 11, 2003, Office Action.  
U.S. Appl. No. 09/732,835, Mail Date Feb. 9, 2004, Office Action.  
U.S. Appl. No. 09/732,835, Mail Date Mar. 17, 2004, Notice of Allowance.  
U.S. Appl. No. 09/764,813, Mail Date Mar. 26, 2001, Office Action.  
U.S. Appl. No. 09/764,813, Mail Date Jun. 4, 2001, Notice of Allowance.  
U.S. Appl. No. 09/764,813, Mail Date Aug. 6, 2001, Issue Notification.  
U.S. Appl. No. 09/933,299, Mail Date Feb. 26, 2003, Office Action.  
U.S. Appl. No. 09/933,299, Mail Date Jun. 16, 2003, Notice of Allowance.  
U.S. Appl. No. 09/933,299, Mail Date Sep. 25, 2003, Issue Notification.  
U.S. Appl. No. 09/948,813, Mail Date Jan. 31, 2003, Notice of Allowance.  
U.S. Appl. No. 09/948,813, Mail Date Jun. 5, 2003, Issue Notification.  
U.S. Appl. No. 09/949,398, Mail Date Mar. 4, 2003, Office Action.  
U.S. Appl. No. 09/949,398, Mail Date Jul. 28, 2003, Notice of Allowance.  
U.S. Appl. No. 09/949,398, Mail Date Dec. 11, 2003, Issue Notification.  
U.S. Appl. No. 09/949,438, Mail Date Dec. 17, 2002, Office Action.  
U.S. Appl. No. 09/949,438, Mail Date Apr. 21, 2003, Notice of Allowance.  
U.S. Appl. No. 09/949,438, Mail Date Aug. 21, 2003, Issue Notification.  
U.S. Appl. No. 10/006,400, Mail Date Aug. 27, 2004, Office Action.  
U.S. Appl. No. 10/006,400, Mail Date Feb. 23, 2005, Office Action.  
U.S. Appl. No. 10/006,400, Mail Date Apr. 11, 2005, Office Action.  
U.S. Appl. No. 10/006,400, Mail Date Jul. 27, 2005, Office Action.  
U.S. Appl. No. 10/006,400, Mail Date Mar. 6, 2006, Office Action.  
U.S. Appl. No. 10/006,400, Mail Date May 24, 2006, Office Action.  
U.S. Appl. No. 10/006,400, Mail Date Oct. 26, 2006, Office Action.  
U.S. Appl. No. 10/006,400, Mail Date Apr. 19, 2007, Office Action.  
U.S. Appl. No. 10/006,400, Mail Date Apr. 2, 2008, Office Action.  
U.S. Appl. No. 10/081,717, Mail Date Sep. 29, 2003, Notice of Allowance.  
U.S. Appl. No. 10/081,717, Mail Date Feb. 5, 2004, Issue Notification.  
U.S. Appl. No. 10/081,723, Mail Date Sep. 29, 2004, Office Action.  
U.S. Appl. No. 10/081,723, Mail Date May 13, 2005, Notice of Allowance.  
U.S. Appl. No. 10/081,725, Mail Date Feb. 9, 2004, Notice of Allowance.  
U.S. Appl. No. 10/081,725, Mail Date Apr. 13, 2004, Office Action.  
U.S. Appl. No. 10/081,725, Mail Date May 27, 2004, Issue Notification.  
U.S. Appl. No. 10/081,726, Mail Date Apr. 11, 2003, Notice of Allowance.  
U.S. Appl. No. 10/081,726, Mail Date Jun. 9, 2003, Office Action.  
U.S. Appl. No. 10/081,726, Mail Date Sep. 4, 2003, Issue Notification.  
U.S. Appl. No. 10/147,774, Mail Date Nov. 4, 2004, Office Action.  
U.S. Appl. No. 10/147,774, Mail Date May 4, 2004, Office Action.  
U.S. Appl. No. 10/147,774, Mail Date Oct. 18, 2005, Office Action.  
U.S. Appl. No. 10/147,774, Mail Date Apr. 18, 2007, Notice of Allowance.  
U.S. Appl. No. 10/147,774, Mail Date Sep. 27, 2007, Notice of Allowance.  
U.S. Appl. No. 10/147,774, Mail Date Feb. 4, 2004, Notice of Allowance.  
U.S. Appl. No. 10/147,774, Mail Date Jun. 30, 2008, Office Action.  
U.S. Appl. No. 10/240,183, Mail Date Jul. 27, 2004, Office Action.  
U.S. Appl. No. 10/240,183, Mail Date Dec. 17, 2004, Office Action.  
U.S. Appl. No. 10/240,183, Mail Date Mar. 9, 2005, Notice of Allowance.  
U.S. Appl. No. 10/240,183, Mail Date Aug. 11, 2006, Office Action.  
U.S. Appl. No. 10/264,306, Mail Date Feb. 9, 2005, Office Action.  
U.S. Appl. No. 10/264,306, Mail Date May 26, 2005, Office Action.  
U.S. Appl. No. 10/264,306, Mail Date Oct. 4, 2005, Office Action.  
U.S. Appl. No. 10/264,306, Mail Date May 10, 2006, Notice of Allowance.  
U.S. Appl. No. 10/264,306, Mail Date Jul. 2, 2007, Notice of Allowance.  
U.S. Appl. No. 10/264,306, Mail Date Feb. 4, 2008, Notice of Allowance.  
U.S. Appl. No. 10/264,306, Mail Date Jun. 27, 2008, Office Action.  
U.S. Appl. No. 10/335,075, Mail Date Aug. 10, 2005, Office Action.  
U.S. Appl. No. 10/335,075, Mail Date Dec. 19, 2005, Office Action.  
U.S. Appl. No. 10/335,075, Mail Date Apr. 21, 2006, Office Action.  
U.S. Appl. No. 10/335,075, Mail Date Dec. 27, 2006, Notice of Allowance.  
U.S. Appl. No. 10/335,075, Mail Date Apr. 11, 2007, Issue Notification.  
U.S. Appl. No. 10/356,214, Mail Date Nov. 30, 2005, Office Action.  
U.S. Appl. No. 10/356,214, Mail Date Aug. 23, 2006, Office Action.  
U.S. Appl. No. 10/356,214, Mail Date Feb. 13, 2007, Office Action.  
U.S. Appl. No. 10/356,214, Mail Date Sep. 12, 2007, Office Action.  
U.S. Appl. No. 10/356,214, Mail Date Mar. 6, 2008, Office Action.  
U.S. Appl. No. 10/435,104, Mail Date Jun. 10, 2004, Office Action.  
U.S. Appl. No. 10/435,104, Mail Date Sep. 21, 2004, Notice of Allowance.  
U.S. Appl. No. 10/435,104, Mail Date Jan. 3, 2006, Office Action.  
U.S. Appl. No. 10/435,104, Mail Date Feb. 15, 2006, Issue Notification.  
U.S. Appl. No. 10/435,104, Mail Date May 16, 2006, Office Action.  
U.S. Appl. No. 10/435,104, Mail Date Dec. 28, 2006, Notice of Allowance.  
U.S. Appl. No. 10/435,104, Mail Date May 23, 2007, Issue Notification.  
U.S. Appl. No. 10/435,104, Mail Date Jul. 10, 2007, Notice of Allowance.  
U.S. Appl. No. 10/435,104, Mail Date Aug. 2, 2007, Notice of Allowance.  
U.S. Appl. No. 10/435,104, Mail Date Oct. 26, 2007, Notice of Allowance.  
U.S. Appl. No. 10/435,104, Mail Date Apr. 4, 2008, Notice of Allowance.  
U.S. Appl. No. 10/435,104, Mail Date Sep. 26, 2008, Notice of Allowance.

- U.S. Appl. No. 10/455,768, Mail Date Nov. 16, 2004, Office Action.  
 U.S. Appl. No. 10/455,768, Mail Date Apr. 6, 2005, Notice of Allowance.  
 U.S. Appl. No. 10/486,067, Mail Date Jan. 10, 2006, Office Action.  
 U.S. Appl. No. 10/486,067, Mail Date Sep. 20, 2006, Notice of Allowance.  
 U.S. Appl. No. 10/486,067, Mail Date Dec. 27, 2006, Issue Notification.  
 U.S. Appl. No. 10/486,070, Mail Date Apr. 20, 2005, Office Action.  
 U.S. Appl. No. 10/486,070, Mail Date Aug. 10, 2005, Office Action.  
 U.S. Appl. No. 10/486,070, Mail Date Oct. 18, 2005, Notice of Allowance.  
 U.S. Appl. No. 10/517,004, Mail Date Aug. 13, 2007, Office Action.  
 U.S. Appl. No. 10/517,004, Mail Date Jan. 30, 2008, Office Action.  
 U.S. Appl. No. 10/519,778, Mail Date Feb. 23, 2006, Office Action.  
 U.S. Appl. No. 10/519,778, Mail Date May 31, 2006, Notice of Allowance.  
 U.S. Appl. No. 10/541,083, Mail Date Oct. 16, 2007, Office Action.  
 U.S. Appl. No. 10/541,083, Mail Date May 5, 2008, Office Action.  
 U.S. Appl. No. 10/541,083, Mail Date Sep. 19, 2008, Notice of Allowance.  
 U.S. Appl. No. 10/616,832, Mail Date Jun. 30, 2006, Office Action.  
 U.S. Appl. No. 10/616,832, Mail Date Oct. 20, 2006, Office Action.  
 U.S. Appl. No. 10/616,832, Mail Date May 29, 2007, Office Action.  
 U.S. Appl. No. 10/616,832, Mail Date Jan. 22, 2008, Office Action.  
 U.S. Appl. No. 10/616,832, Mail Date Sep. 17, 2008, Office Action.  
 U.S. Appl. No. 10/617,090, Mail Date Mar. 22, 2005, Office Action.  
 U.S. Appl. No. 10/617,090, Mail Date Jul. 6, 2005, Notice of Allowance.  
 U.S. Appl. No. 10/617,090, Mail Date Oct. 5, 2005, Notice of Allowance.  
 U.S. Appl. No. 10/617,090, Mail Date Feb. 1, 2006, Issue Notification.  
 U.S. Appl. No. 10/638,115, Mail Date Sep. 22, 2006, Office Action.  
 U.S. Appl. No. 10/638,115, Mail Date Jan. 31, 2007, Office Action.  
 U.S. Appl. No. 10/638,115, Mail Date Sep. 18, 2007, Office Action.  
 U.S. Appl. No. 10/638,115, Mail Date Feb. 7, 2008, Office Action.  
 U.S. Appl. No. 10/638,115, Mail Date May 7, 2009, Notice of Allowance.  
 U.S. Appl. No. 10/667,144, Mail Date Sep. 19, 2006, Office Action.  
 U.S. Appl. No. 10/667,144, Mail Date May 2, 2007, Office Action.  
 U.S. Appl. No. 10/667,144, Mail Date Nov. 19, 2007, Office Action.  
 U.S. Appl. No. 10/667,144, Mail Date Dec. 5, 2007, Office Action.  
 U.S. Appl. No. 10/667,144, Mail Date May 12, 2008, Office Action.  
 U.S. Appl. No. 10/682,459, Mail Date Sep. 15, 2006, Office Action.  
 U.S. Appl. No. 10/682,459, Mail Date Apr. 18, 2007, Office Action.  
 U.S. Appl. No. 10/682,459, Mail Date Apr. 2, 2008, Office Action.  
 U.S. Appl. No. 10/786,444, Mail Date Oct. 30, 2006, Office Action.  
 U.S. Appl. No. 10/786,444, Mail Date Apr. 17, 2007, Office Action.  
 U.S. Appl. No. 10/786,444, Mail Date Aug. 31, 2007, Office Action.  
 U.S. Appl. No. 10/786,444, Mail Date Apr. 24, 2008, Office Action.  
 U.S. Appl. No. 10/786,444, Mail Date Oct. 17, 2008, Office Action.  
 U.S. Appl. No. 10/787,073, Mail Date Nov. 30, 2006, Office Action.  
 U.S. Appl. No. 10/787,073, Mail Date Sep. 5, 2007, Office Action.  
 U.S. Appl. No. 10/787,073, Mail Date Feb. 22, 2008, Office Action.  
 U.S. Appl. No. 10/908,721, Mail Date Oct. 19, 2006, Office Action.  
 U.S. Appl. No. 10/908,721, Mail Date Aug. 10, 2007, Office Action.  
 U.S. Appl. No. 10/908,721, Mail Date Jan. 25, 2008, Office Action.  
 U.S. Appl. No. 11/113,549, Mail Date Feb. 6, 2007, Office Action.  
 U.S. Appl. No. 11/113,549, Mail Date May 30, 2007, Office Action.  
 U.S. Appl. No. 11/113,549, Mail Date Nov. 9, 2007, Office Action.  
 U.S. Appl. No. 11,113,549, Mail Date Apr. 16, 2008, Office Action.  
 U.S. Appl. No. 11/152,562, Mail Date May 13, 2008, Office Action.  
 U.S. Appl. No. 11/198,811, Mail Date Aug. 26, 2008, Office Action.  
 U.S. Appl. No. 11/198,811, Mail Date Apr. 6, 2009, Office Action.  
 U.S. Appl. No. 11/344,891, Mail Date Apr. 29, 2008, Office Action.  
 U.S. Appl. No. 11/396,141, Mail Date May 22, 2009, Office Action.  
 U.S. Appl. No. 11/396,731, Mail Date May 22, 2009, Office Action.  
 U.S. Appl. No. 11/406,203, Mail Date May 14, 2007, Office Action.  
 U.S. Appl. No. 11/406,203, Mail Date Jan. 29, 2008, Notice of Allowance.  
 U.S. Appl. No. 11/406,203, Mail Date May 23, 2008, Notice of Allowance.  
 U.S. Appl. No. 11/406,203, Mail Date Sep. 22, 2008, Notice of Allowance.  
 U.S. Appl. No. 11/411,925, Mail Date Jun. 6, 2007, Office Action.  
 U.S. Appl. No. 11/411,925, Mail Date Feb. 5, 2008, Office Action.  
 U.S. Appl. No. 11/411,925, Mail Date Jan. 12, 2009, Office Action.  
 JP2003-570704, Mail Date Jan. 13, 2009, Japanese Office Action.  
 U.S. Appl. No. 60/843,325, Sep. 8, 2006, Carly.  
 U.S. Appl. No. 60/946,030, Jun. 25, 2007, Voss et al.  
 U.S. Appl. No. 60,946,042, Jun. 25, 2007, Ellingwood et al.  
 U.S. Appl. No. 12/113,092, Apr. 30, 2008, Ginn et al.  
 “Hand tool for forming telephone connections—comprises pliers with reciprocally driven ram crimping clip around conductors against anvil”, Derwent-ACC-No. 1978-B8090A.  
 Database WPI; Section PQ, Week 200120; Derwent Publications Ltd., London GB; AN 2001-203165; XP002199926 & ZA 200 100 528 A (Anthony T), Feb. 28, 2001 abstract.  
 Deepak Mital et al, Renal Transplantation Without Sutures Using the Vascular Clipping System for Renal Artery and Vein Anastomosis—A New Technique, Transplantation Issue, Oct. 1996, pp. 1171-1173, vol. 62-No. 8, Section of Transplantation Surgery, Department of General Surgery, Rush-Presbyterian/St. Luke’s Medical Center, Chicago, IL.  
 DL Wessel et al, Outpatient closure of the patent ductus arteriosus, Circulation, May 1988, pp. 1068-1071, vol. 77-No. 5, Department of Anesthesia, Children’s Hospital, Boston, MA.  
 E Pikoulis et al, Arterial reconstruction with vascular clips is safe and quicker than sutured repair, Cardiovascular Surgery, Dec. 1998, pp. 573-578(6), vol. 6-No. 6, Department of Surgery, Uniformed Services University of the Health Sciences, Bethesda, MD.  
 G Gershony et al, Novel vascular sealing device for closure of percutaneous vascular access sites, Cathet. Cardiovasc. Diagn., Jan. 1998, pp. 82-88, vol. 45.  
 H De Swart et al, A new hemostatic puncture closure device for the immediate sealing of arterial puncture sites, American journal of cardiology, Aug. 1993, pp. 445-449, vol. 72-No. 5, Department of Cardiology, Academic Hospital Maastricht, The Netherlands.  
 Harri M. Hasson M.D., Laparoscopic Cannula Cone with Means for Cannula Stabilization and Wound Closure, The Journal of the American Association of Gynecologic Laparoscopists, May 1998, pp. 183-185, vol. 5-No. 2, Division of Obstetrics and Gynecology, University of Chicago, Chicago, IL.  
 J. Findlay et al, Carotid Arteriectomy Closure Using a Vascular Clip System, Neurosurgery, Mar. 1998, pp. 550-554, vol. 42-No. 3, Division of Neurosurgery, University of Alberta, Edmonton, Canada.  
 Jeremy L Gilbert PhD, Wound Closure Biomaterials and Devices, Shock., Mar. 1999, p. 226, vol. 11-No. 3, Institution Northwestern University.  
 Jochen T. Cremer, MD, et al, Different approaches for minimally invasive closure of atrial septal defects, Ann. Thorac. Surg., Nov. 1998, pp. 1648-1652, Vol. 67, a Division of Thoracic and Cardiovascular Surgery, Surgical Center, Hannover Medical School. Hannover, Germany.  
 K Narayanan et al, Simultaneous primary closure of four fasciotomy wounds in a single setting using the Sure-Closure device, Injury, Jul. 1996, pp. 449-451, vol. 27-No. 6, Department of Surgery, Mercy Hospital of Pittsburgh, PA.  
 MD Gonze et al, Complications associated with percutaneous closure devices, Conference: Annual Meeting of the Society for Clinical Vascular Surgery, The American journal of surgery, Mar. 1999, pp. 209-211, vol. 178, No. 3, Department of Surgery, Section of Vascular Surgery, Ochsner Medical Institutions, New Orleans, LA.  
 MD Hellinger et al, Effective peritoneal and fascial closure of abdominal trocar sites utilizing the Endo-Judge, J Laparoendosc Surg., Oct. 1996, pp. 329-332, vol. 6-No. 5, Orlando Regional Medical Center, FL.  
 Michael Gianturco, A Play on Catheterization, Forbes, Dec. 1996, p. 146, vol. 158-No. 15.  
 OM Elashry et al, Comparative clinical study of port-closure techniques following laparoscopic surgery, Department of Surgery, Mallickrodt Institute of Radiography, J Am Coll Surg., Oct. 1996, pp. 335-344, vol. 183-No. 4.  
 P M N Werker, et al, Review of facilitated approaches to vascular anastomosis surgery, Conference: Utrecht MICABG Workshop 2,

The Annals of thoracic surgery, Apr. 1996, pp. S122-S127, vol. 63-No. 6, Department of Plastic, Reconstructive and Hand surgery, University Hospital Utrecht Netherlands Departments of Cardiology and Cardiopulmonary Surgery, Heart Lung Institute, Utrecht Netherlands.; Utrecht University Hospital Utrecht Netherlands.

Peter Rhee MD et al, Use of Titanium Vascular Staples in Trauma, Journal of Trauma-Injury Infection & Critical Care, Dec. 1998, pp. 1097-1099, vol. 45-No. 6, Institution from the Department of Surgery, Washington Hospital Center, Washington DC, and Uniformed Services University of the Health Sciences, Bethesda, Maryland.

ProstarXL—Percutaneous Vascular Surgical Device, www.Archive.org, Jun. 1998, Original Publisher: <http://prostar.com>, may also be found at <http://web.archive.org/web/19980630040429/www.perclose.com/html/prstrxl.html>.

SA Beyer-Enke et al, Immediate sealing of arterial puncture site following femoropopliteal angioplasty: A prospective randomized trial, Cardiovascular and Interventional Radiology 1996, Nov.-Dec. 1996, pp. 406-410, vol. 19-No. 6, Gen Hosp North, Dept Dianost & Intervent Radiol, Nurnberg, Germany (Reprint).

Scott Hensley, Closing Wounds. New Devices seal arterial punctures in double time, Modern Healthcare (United States), Mar. 23, 2008, p. 48.

Sigmund Silber et al, A novel vascular device for closure of percutaneous arterial access sites, The American Journal of Cardiology, Apr. 1999, pp. 1248-1252, vol. 83-No. 8.

Simonetta Blengino et al, A Randomized Study of the 8 French Hemostatic Puncture Closure Device vs Manual Compression After Coronary Interventions, Journal of the American College of Cardiology, Feb. 1995, p. 262A, vol. 25.-No. 2, Supplement 1.

Stretch Comb by Scunci, retrieved via internet at [www.scunci.com/productdetail](http://www.scunci.com/productdetail) by examiner on Oct. 9, 2007, publication date unavailable.

Swee Lian Tan, MD, PHD, FACS, Explanation of Infected Hemostatic Puncture Closure Devices—A Case Report, Vascular and Endovascular Surgery, 1999, pp. 507-510, vol. 33-No. 5, Parkland Medical Center, Derry, New Hampshire.

Sy Nakada et al, Comparison of newer laparoscopic port closure techniques in the porcine model, J Endourol, Oct. 1995, pp. 397-401, vol. 9-No. 5, Department of Surgery/Urology, University of Wisconsin Medical School, Madison.

Thomas P. Baum RPA-C et al, Delayed Primary Closure Using Silastic Vessel Loops and Skin Staples: Description of the Technique and Case Reports, Annals of Plastic Surgery, Mar. 1999, pp. 337-340, vol. 42-No. 3, Institution Department of Plastic and Reconstructive Surgery, Albert Einstein College of Medicine and Montefiore Medical Center, Bronx, NY.

Tomoaki Hinohara, Percutaneous, vascular surgery (Prostar® Plus and Techstar® for femoral artery site closure), Interventional Cardiology Newsletter, May-Jul. 1997, pp. 19-28, vol. 5-No. 3-4.

UT Aker et al, Immediate arterial hemostatis after cardiac catheterization: initial experience with a new puncture closure device, Cathet Cardiovasc Diagn, Mar. 1994, pp. 228-232, vol. 33-No. 3, Missouri Baptist Medical Center, St. Louis.

Wei Qu et al. An absorbable pinned-ring device for microvascular anastomosis of vein grafts: Experimental studies, Microsurgery 1999, Mar. 1999, pp. 128-134, vol. 19-No. 3, Department of Orthopaedic Surgery, Hiroshima University School of Medicine, Hiroshima, Japan.

William G. Kussmaul III MD, et al., Rapid arterial hemostatis and decreased access site complications after cardiac catheterization and angioplasty: Results of a randomized trial of a novel hemostatic device, Journal of the American College of Cardiology, Jun. 1995, pp. 1685-1692, vol. 25-No. 7.

\* cited by examiner



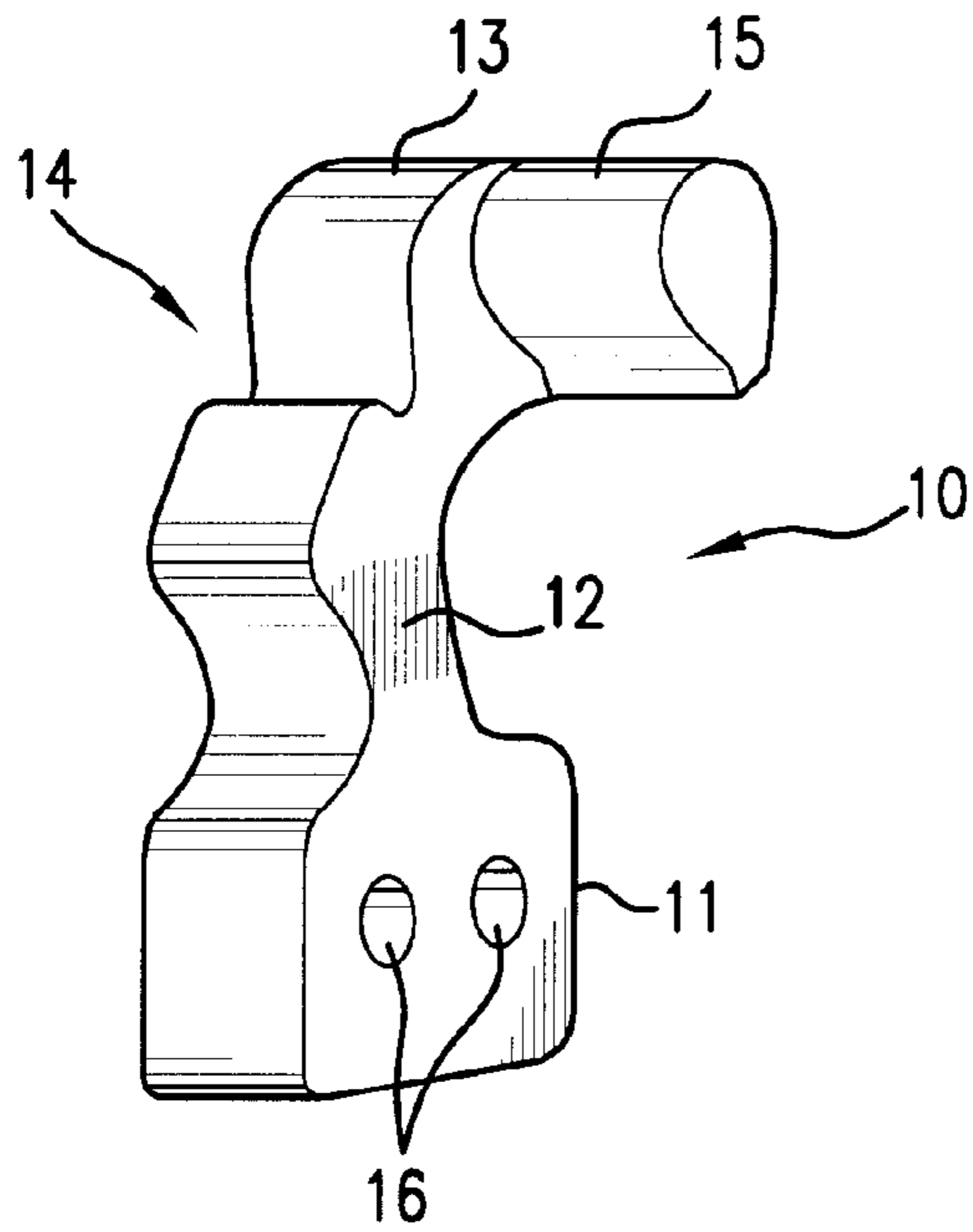

FIG. 1

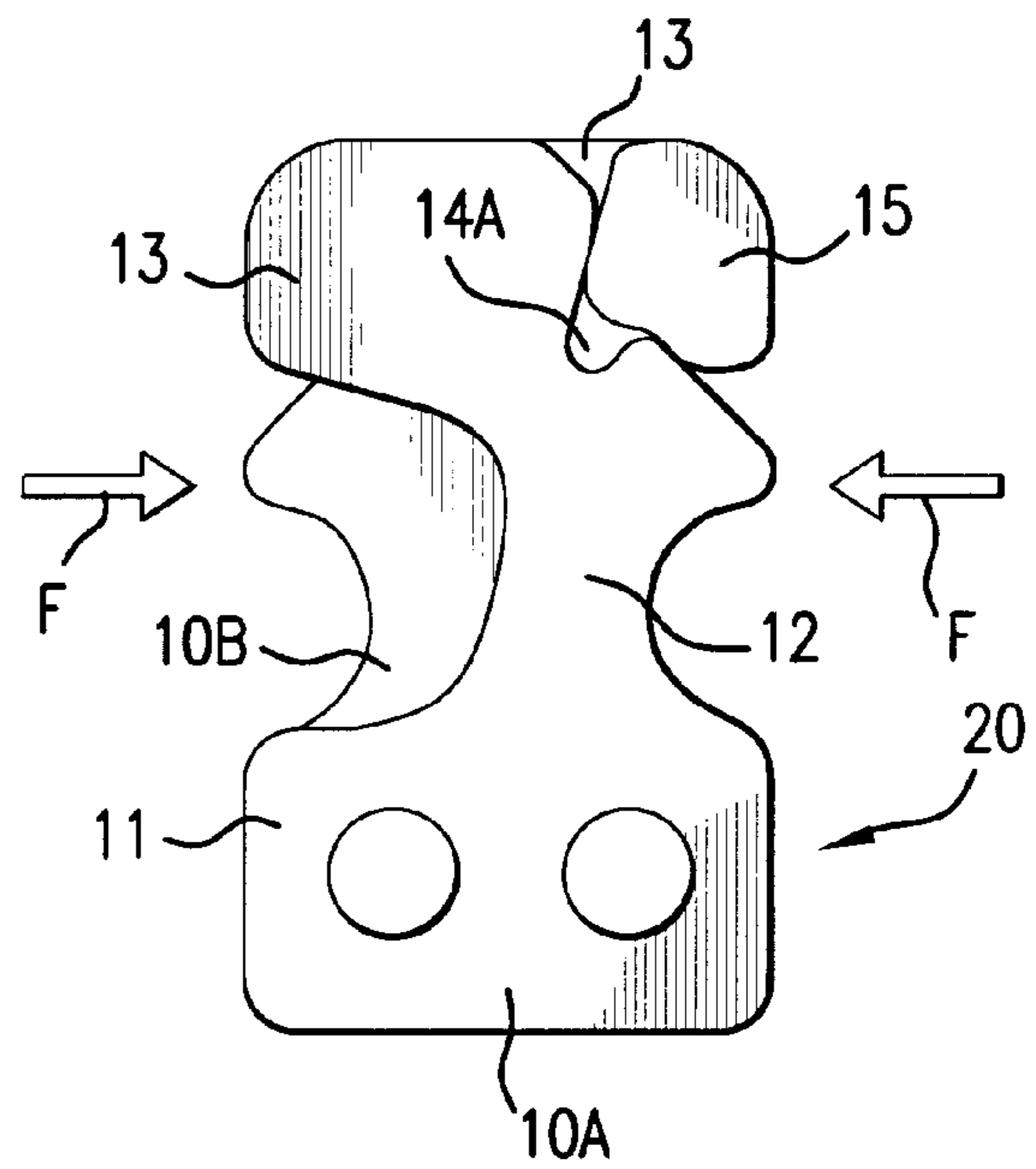

FIG. 3

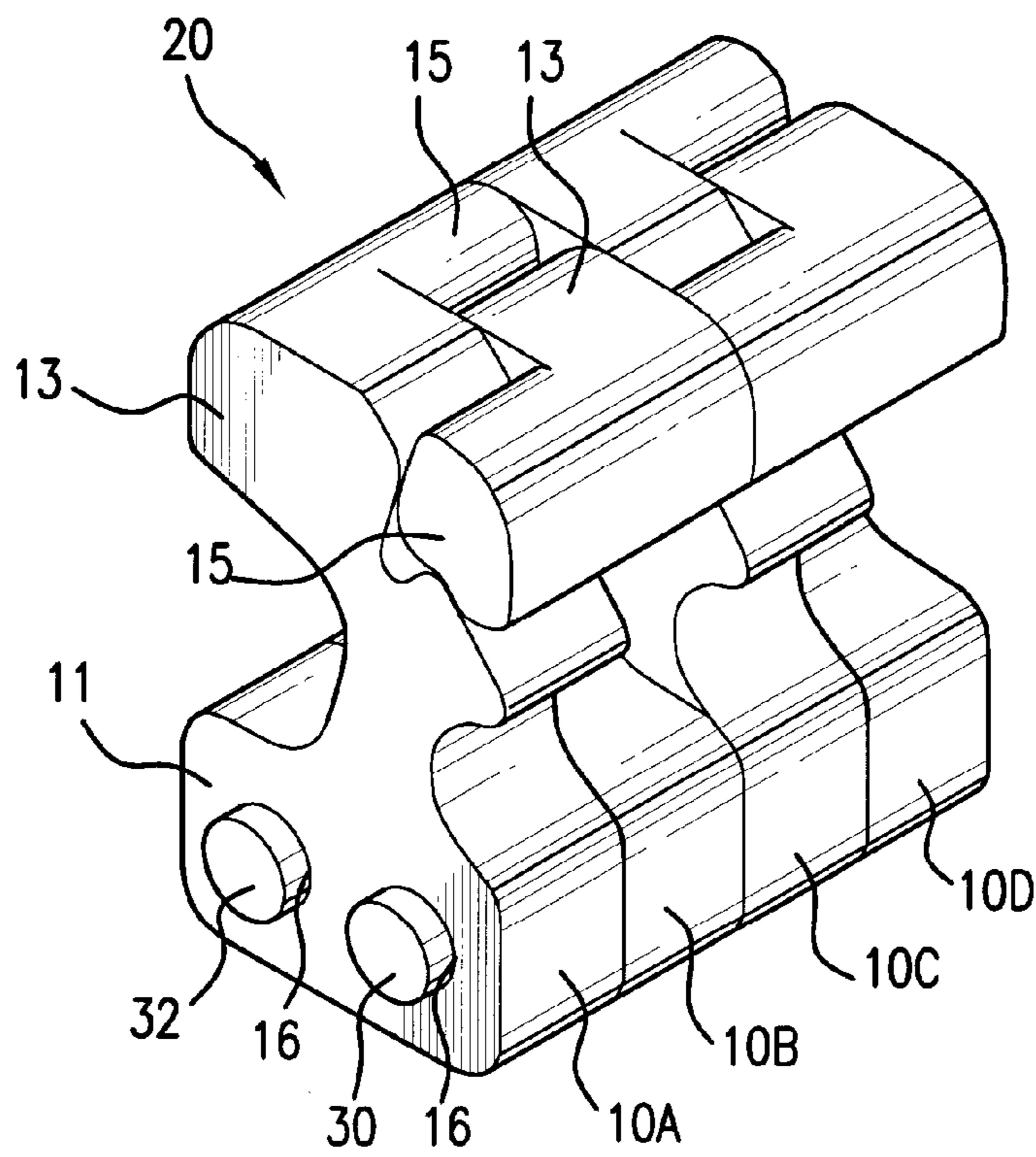

FIG. 2

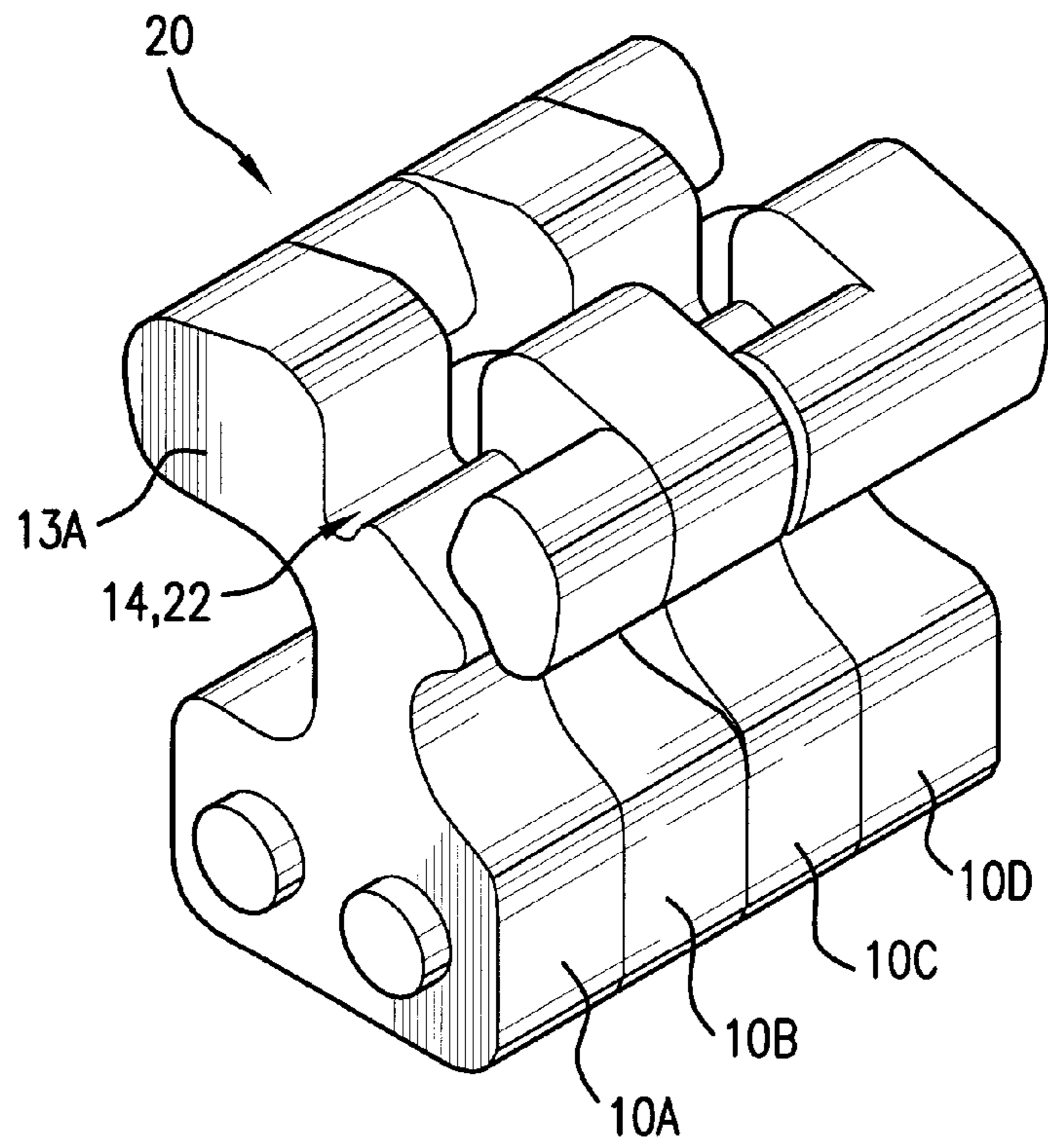

FIG. 4

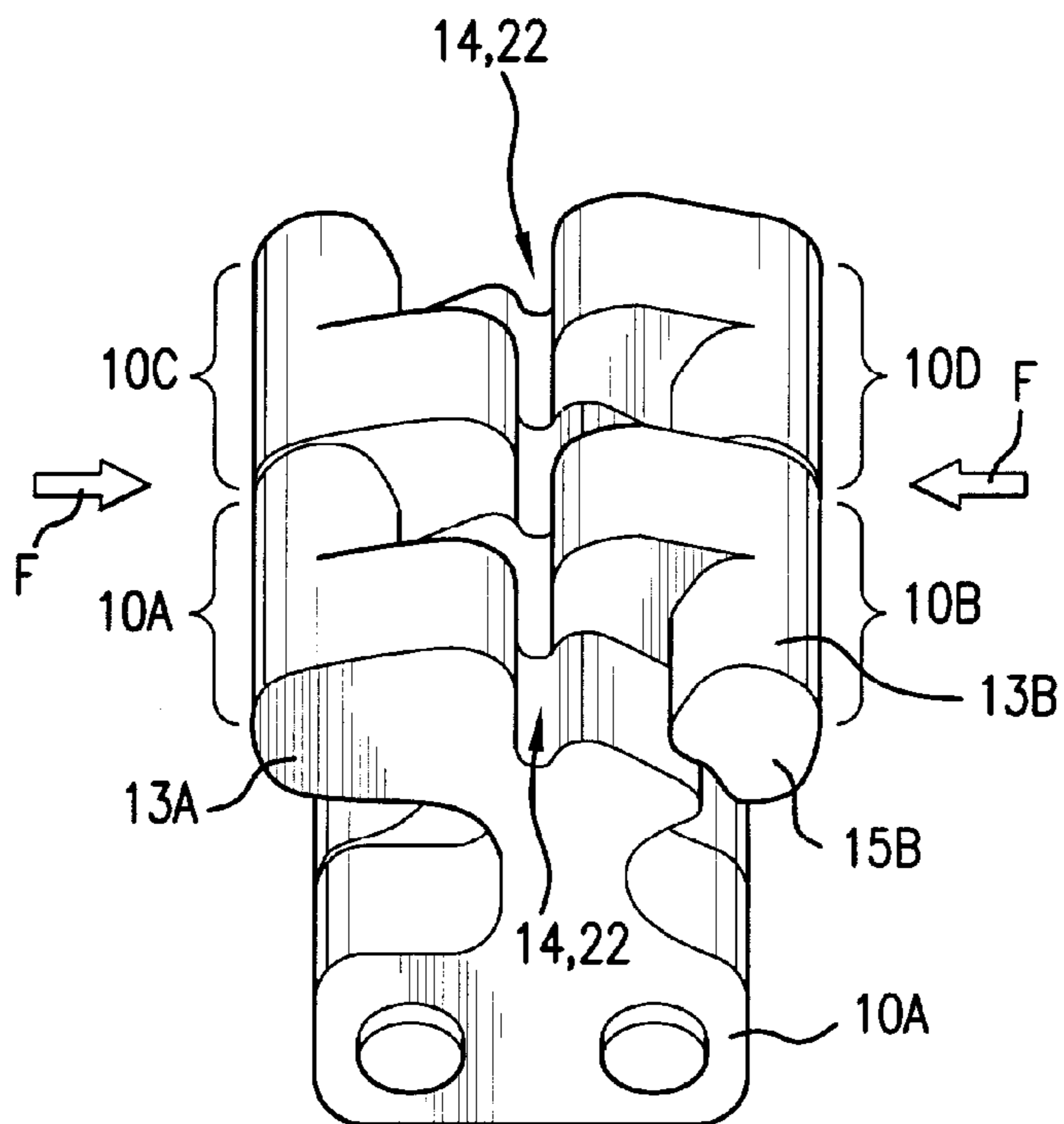

FIG. 5

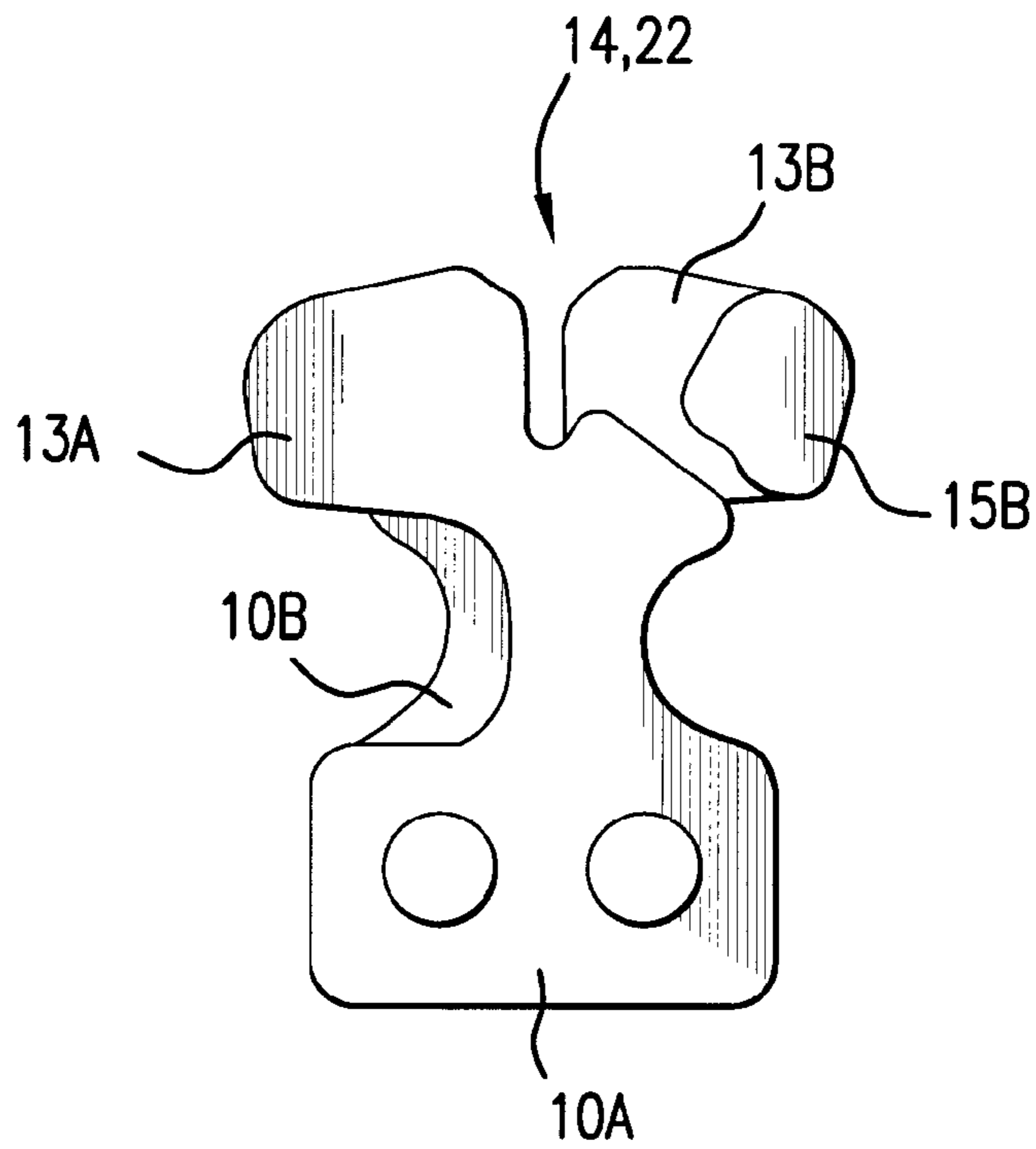

FIG. 6

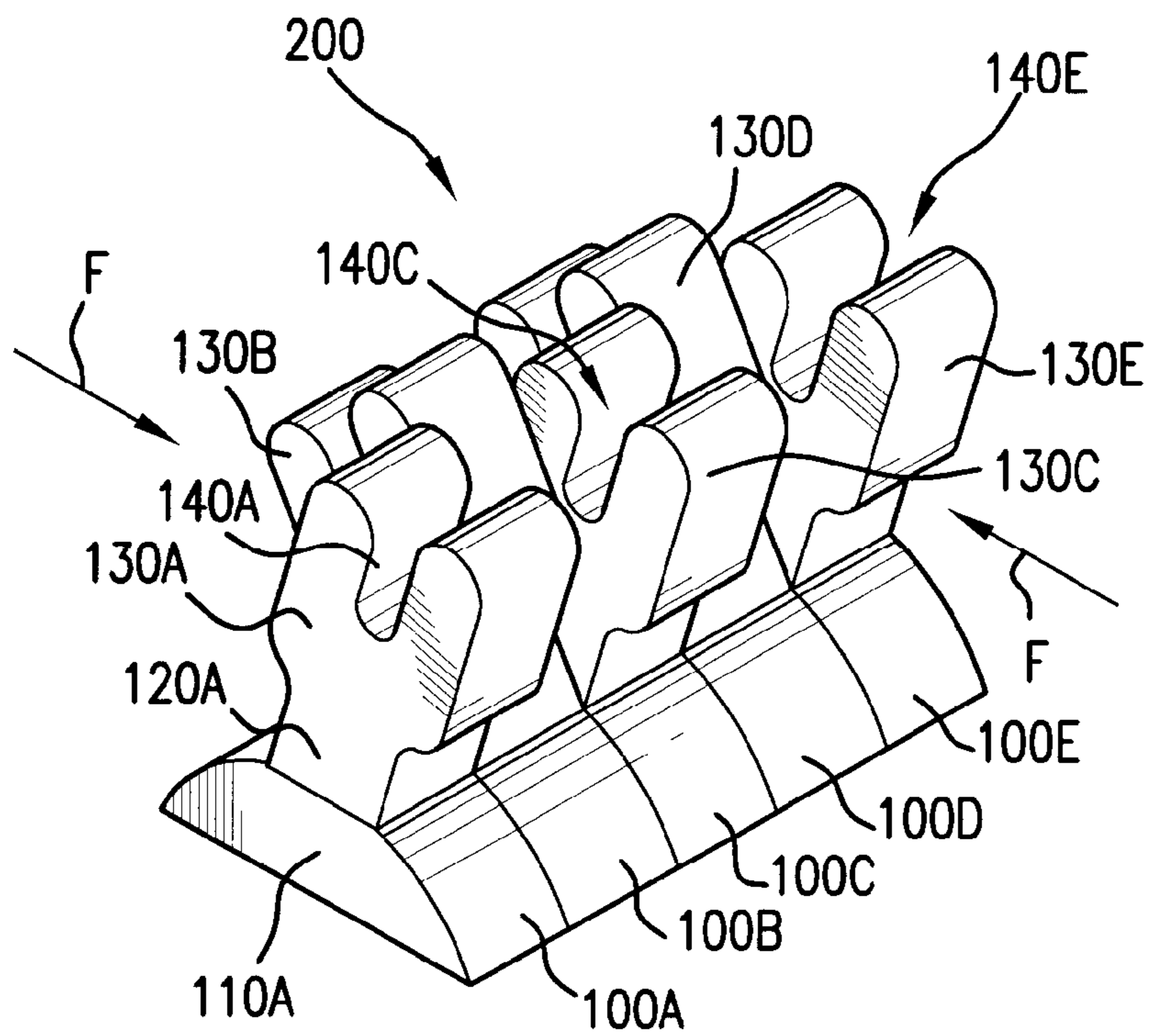

FIG. 7

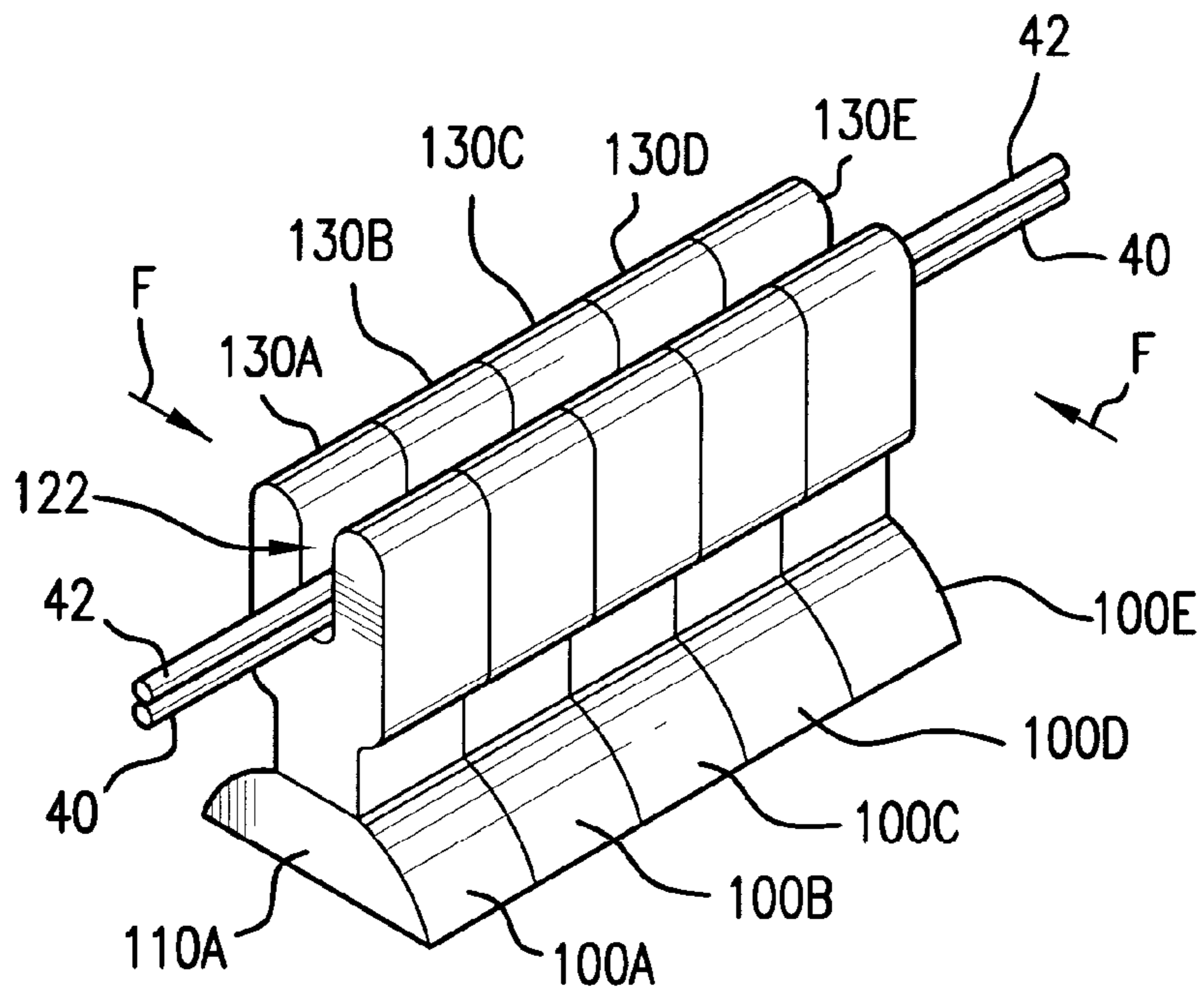

FIG. 8

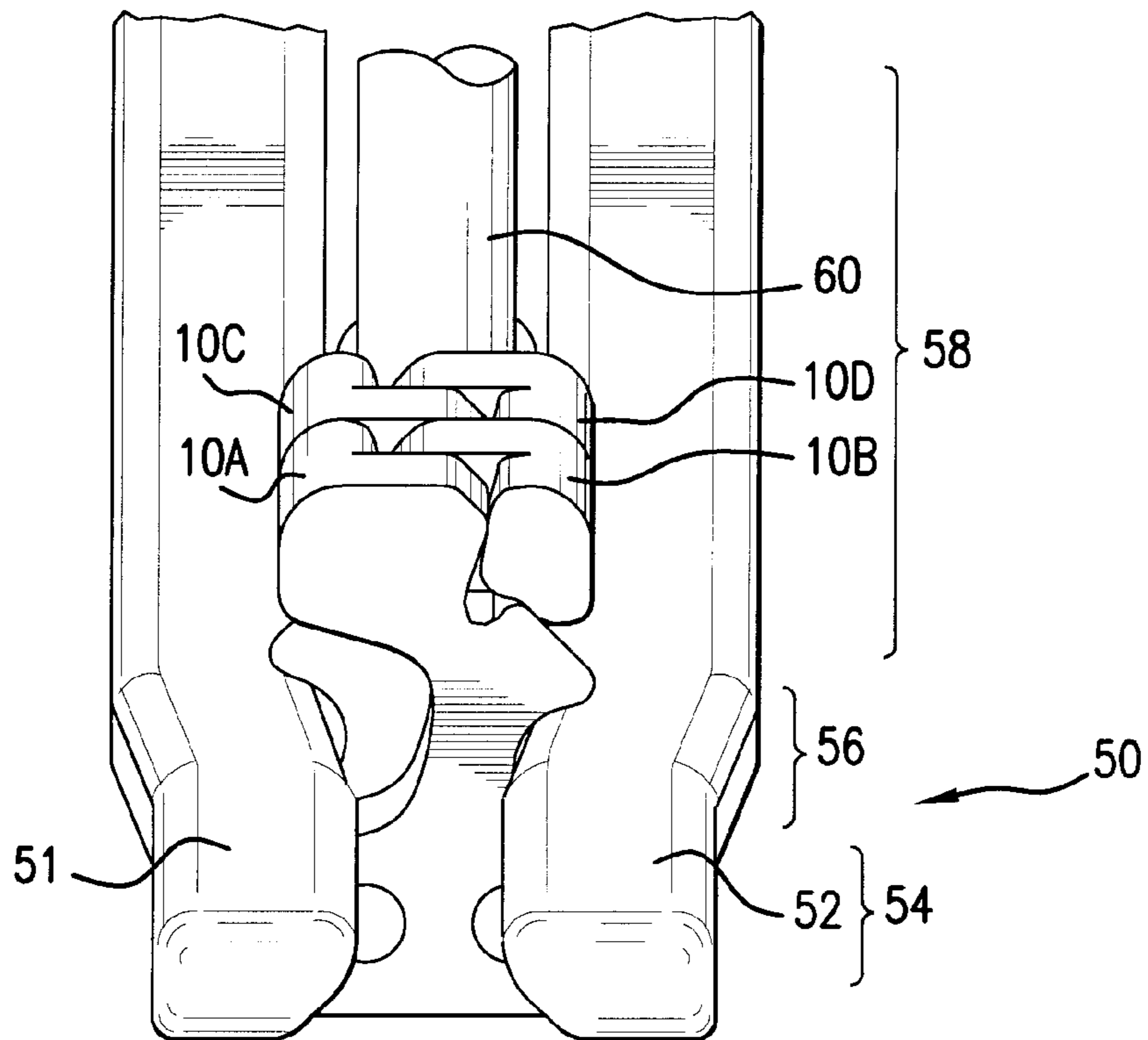

FIG. 9

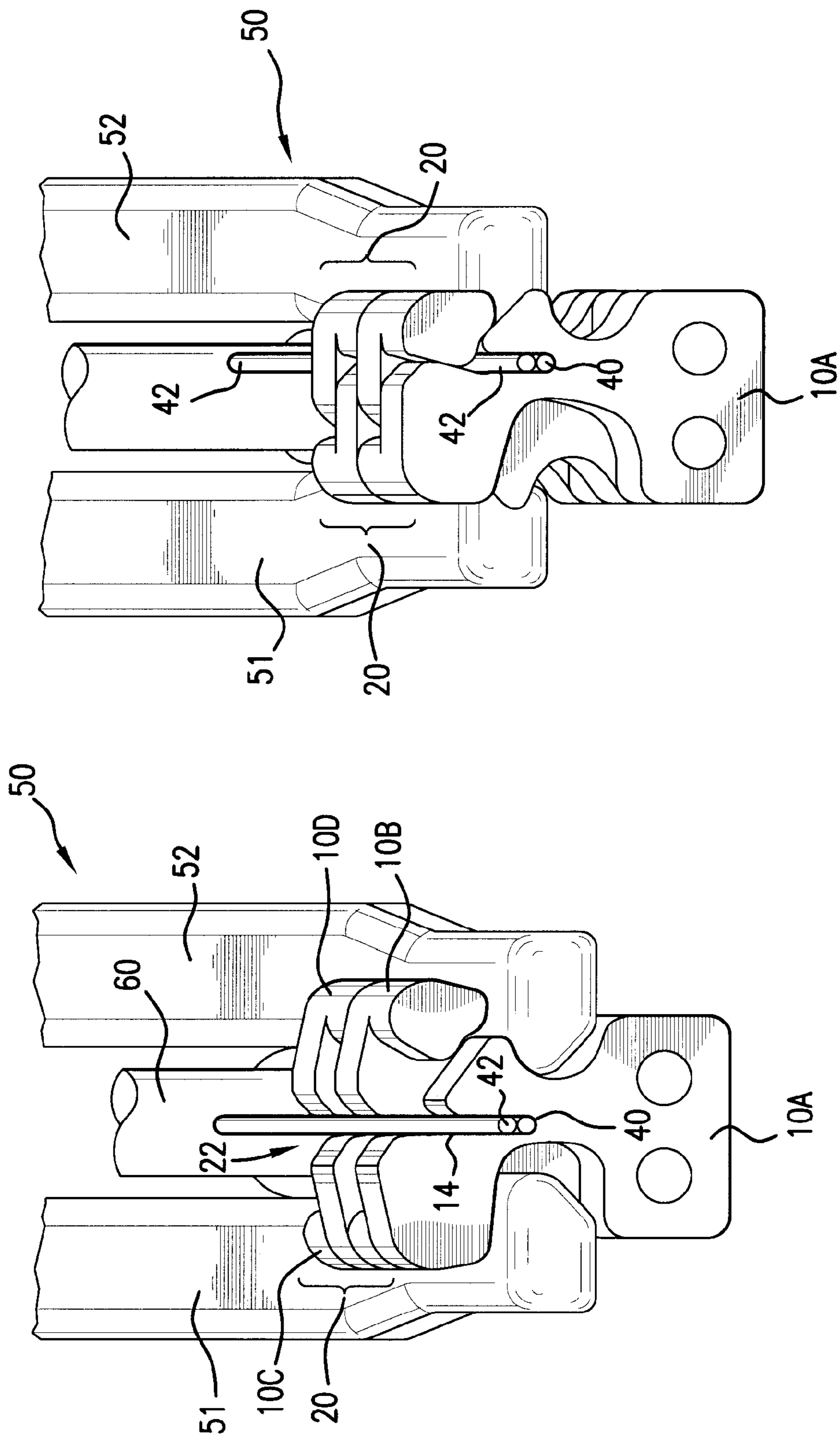

FIG. 11

FIG. 10

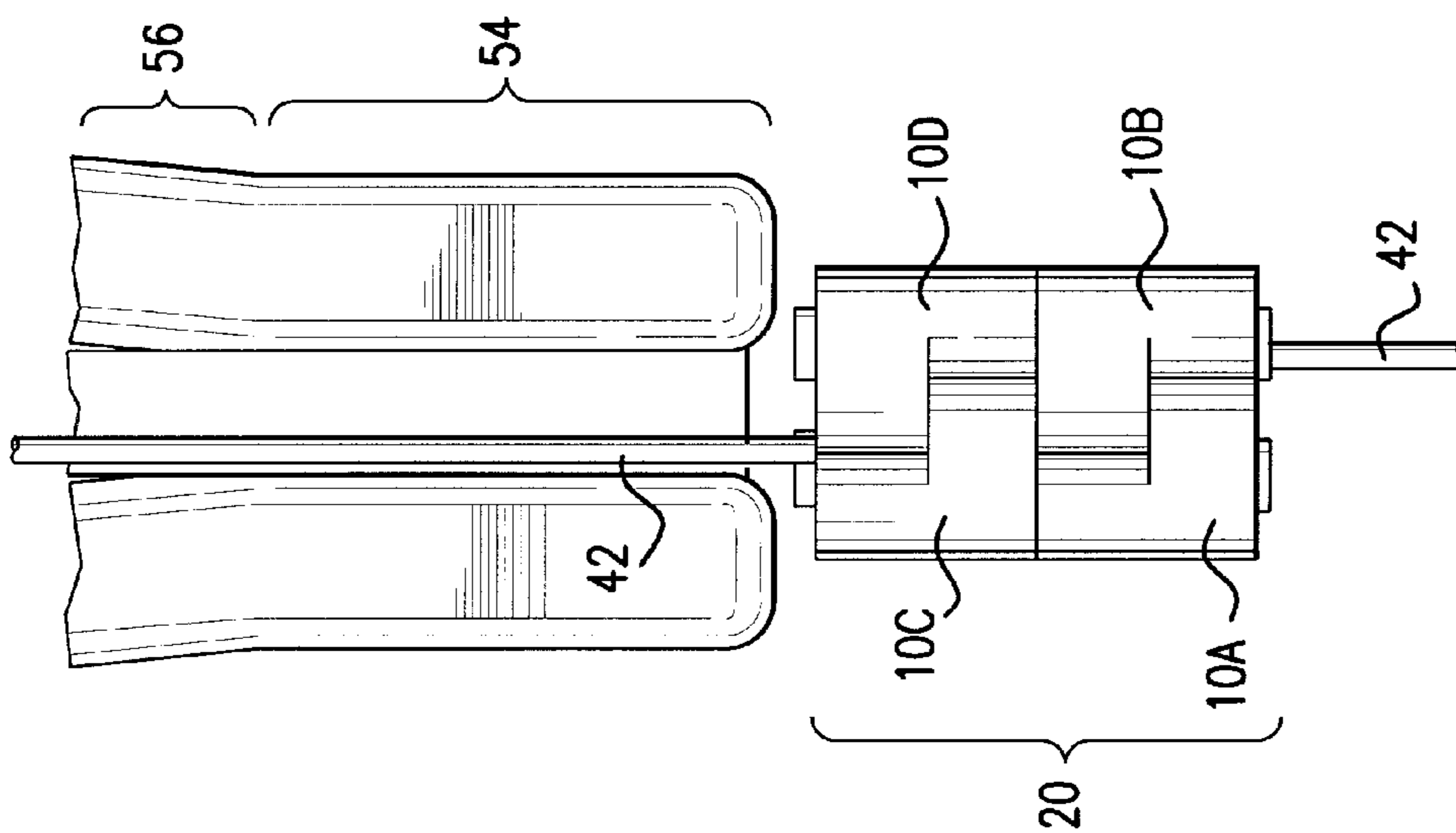

FIG. 12

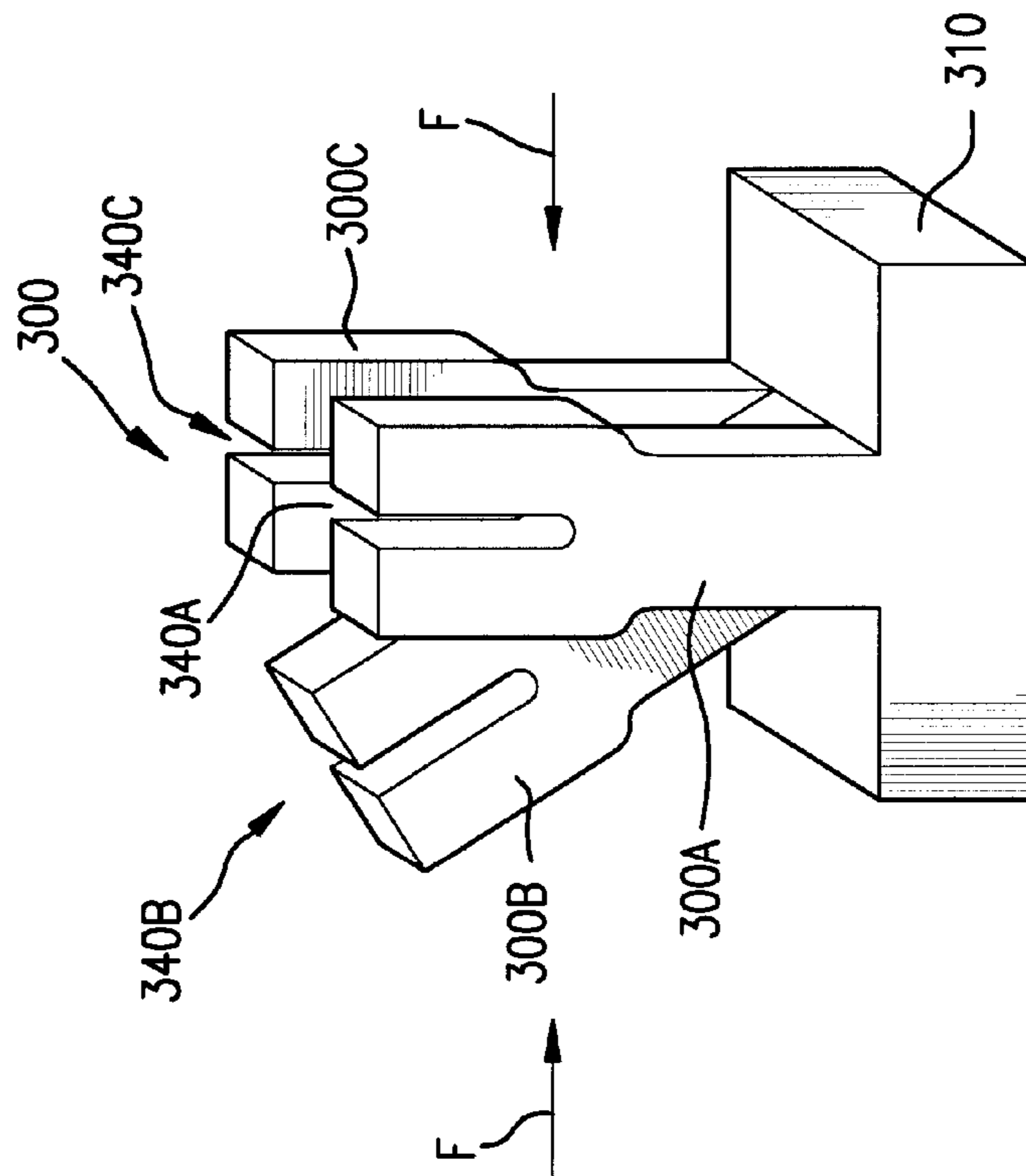

FIG. 13

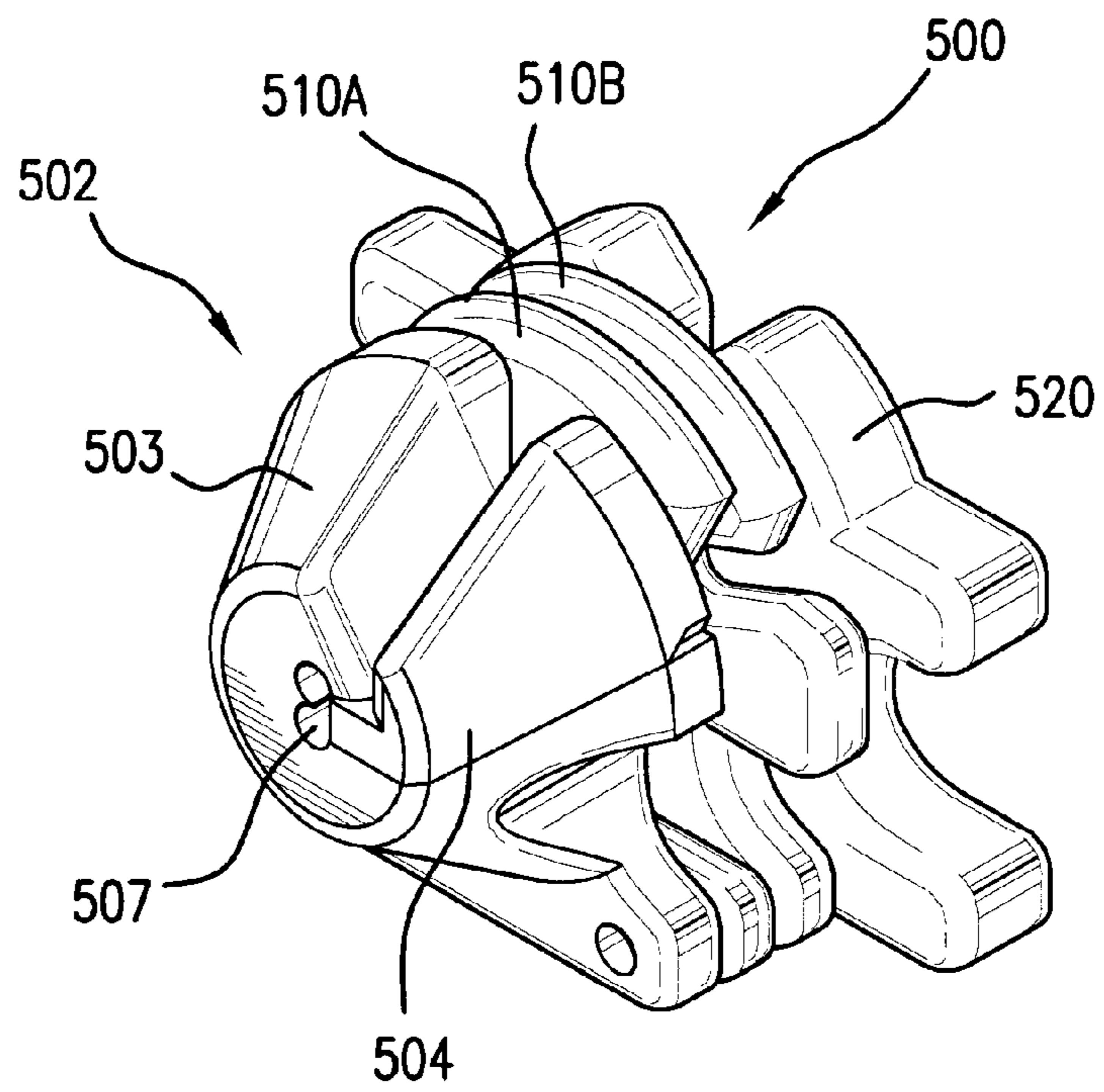

FIG. 14

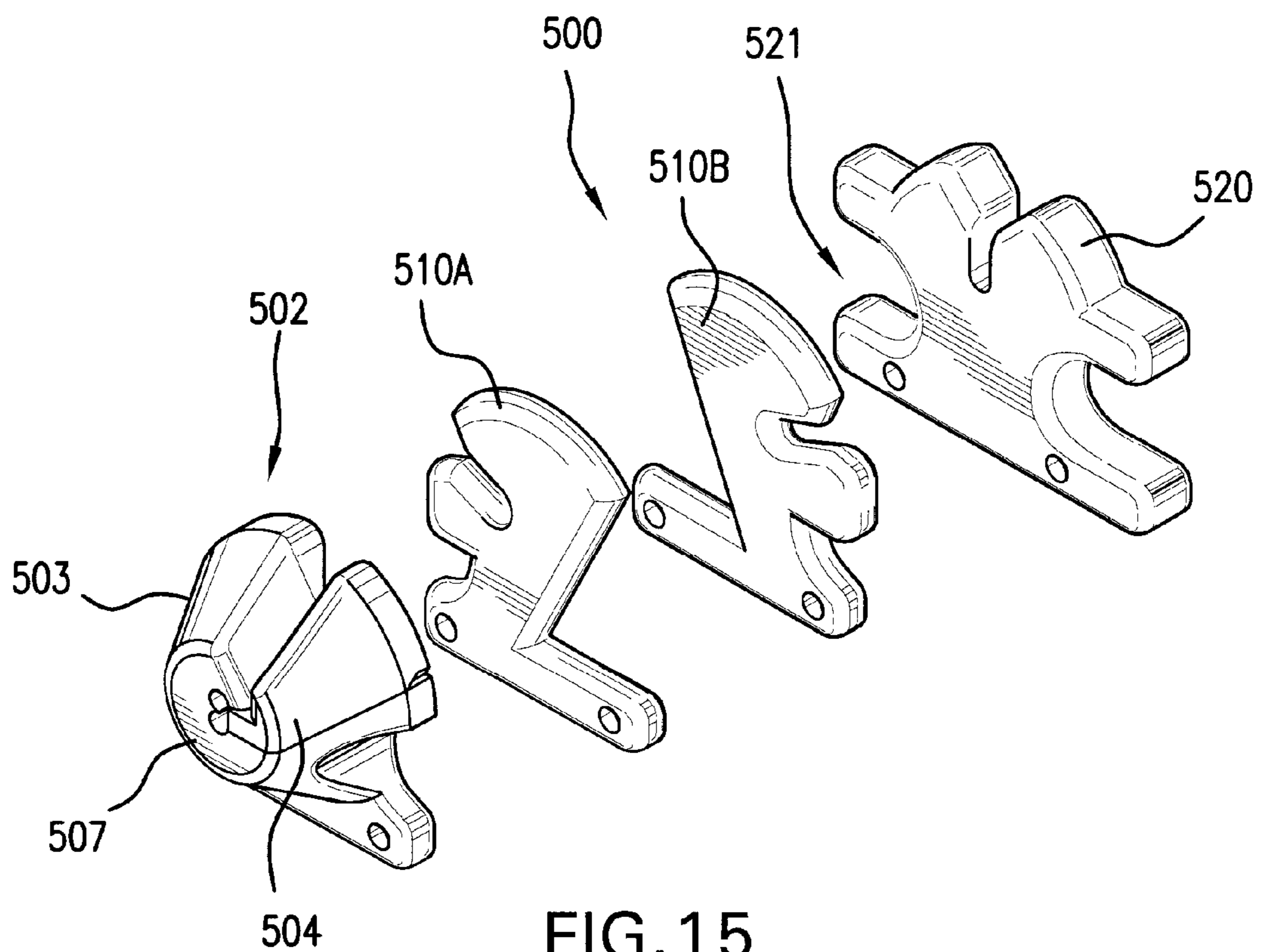

FIG. 15

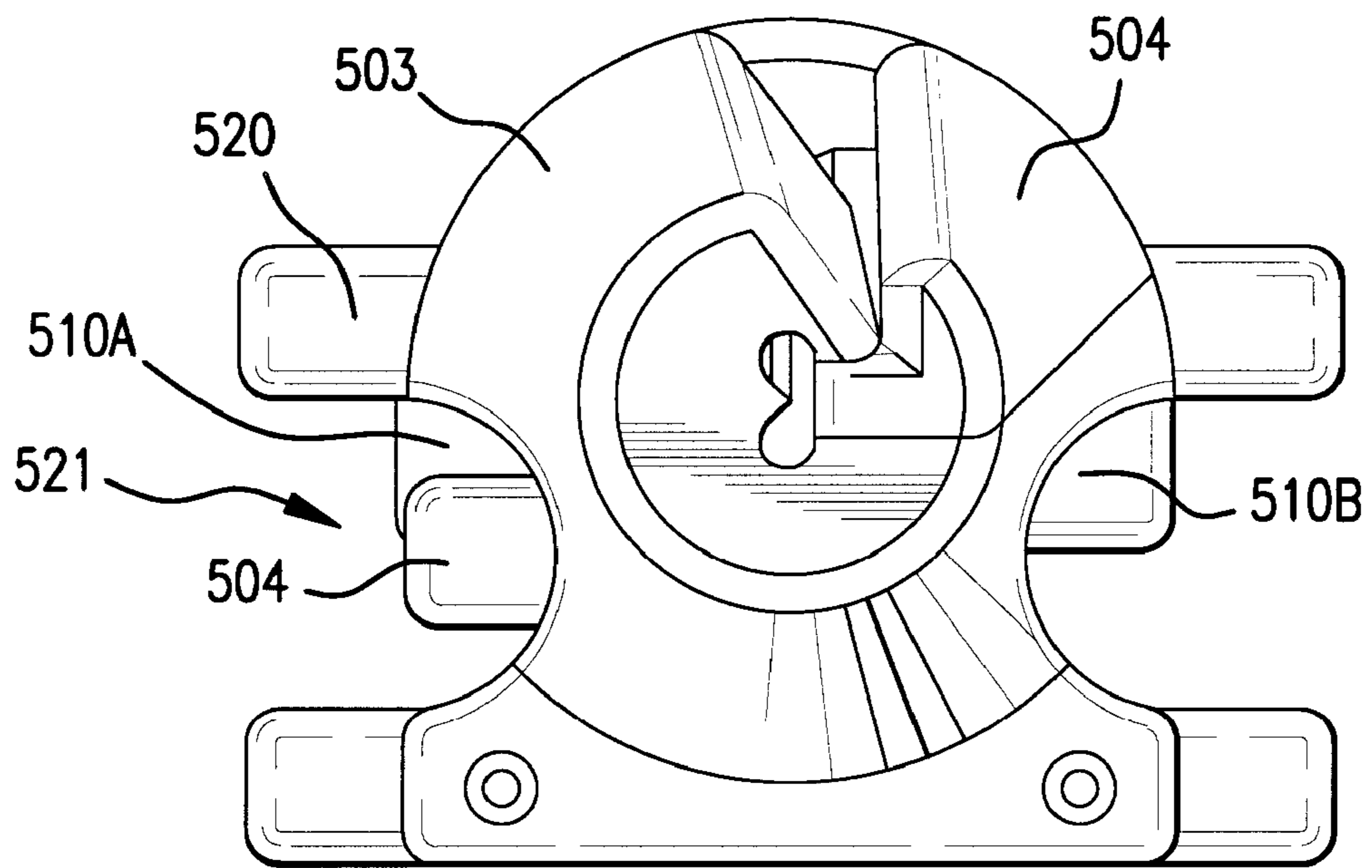

FIG. 16A

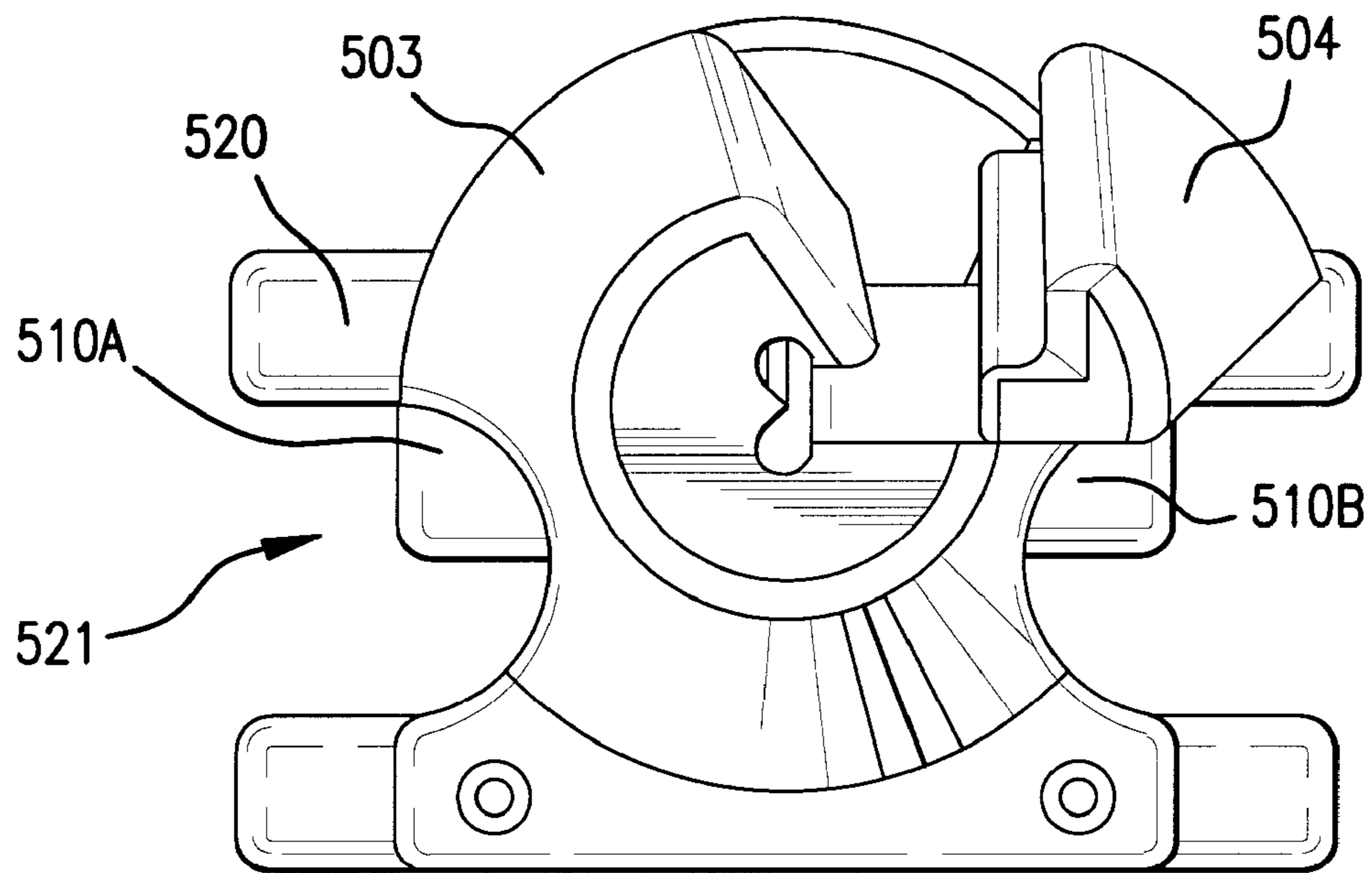

FIG. 16B



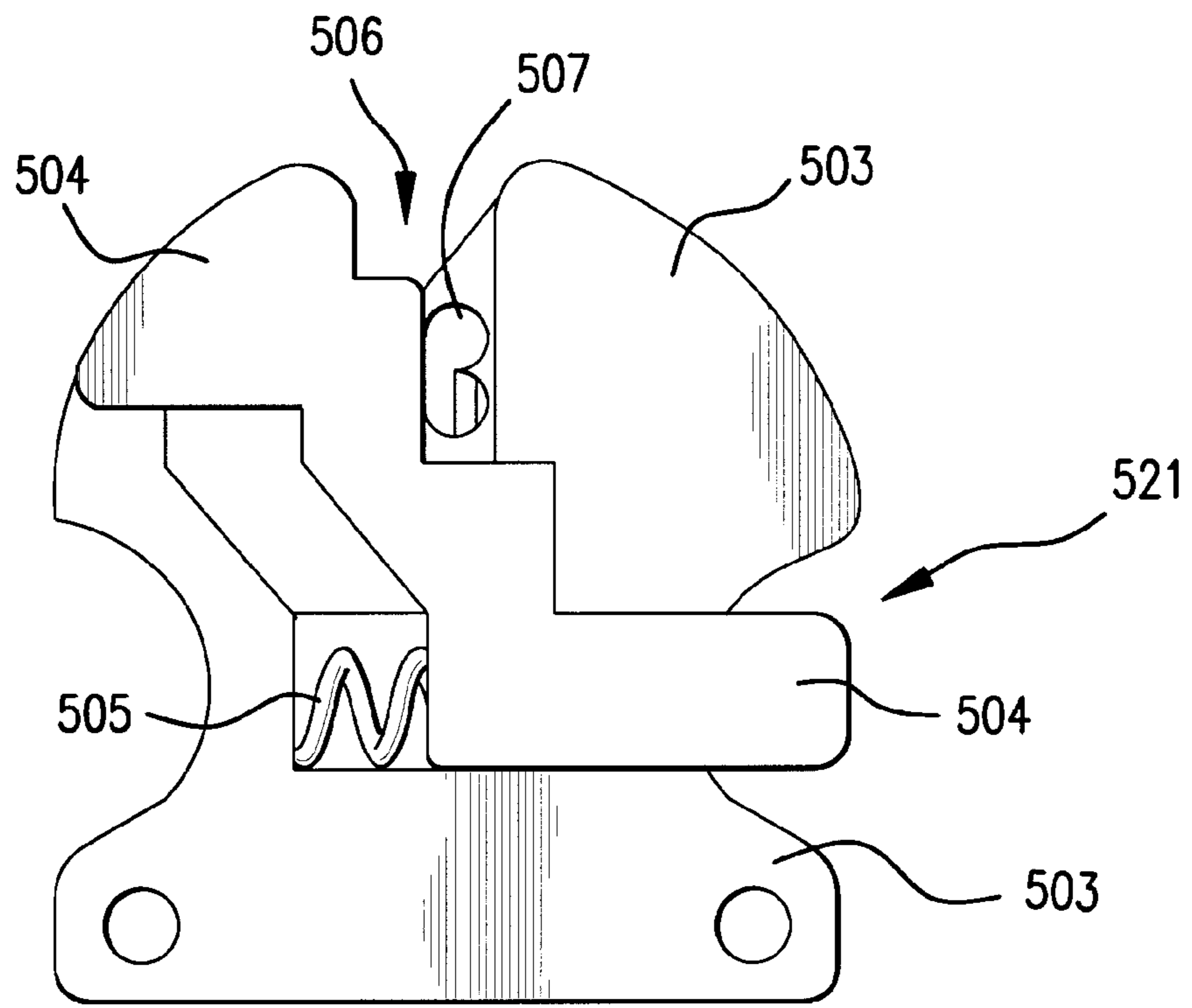

FIG. 17A

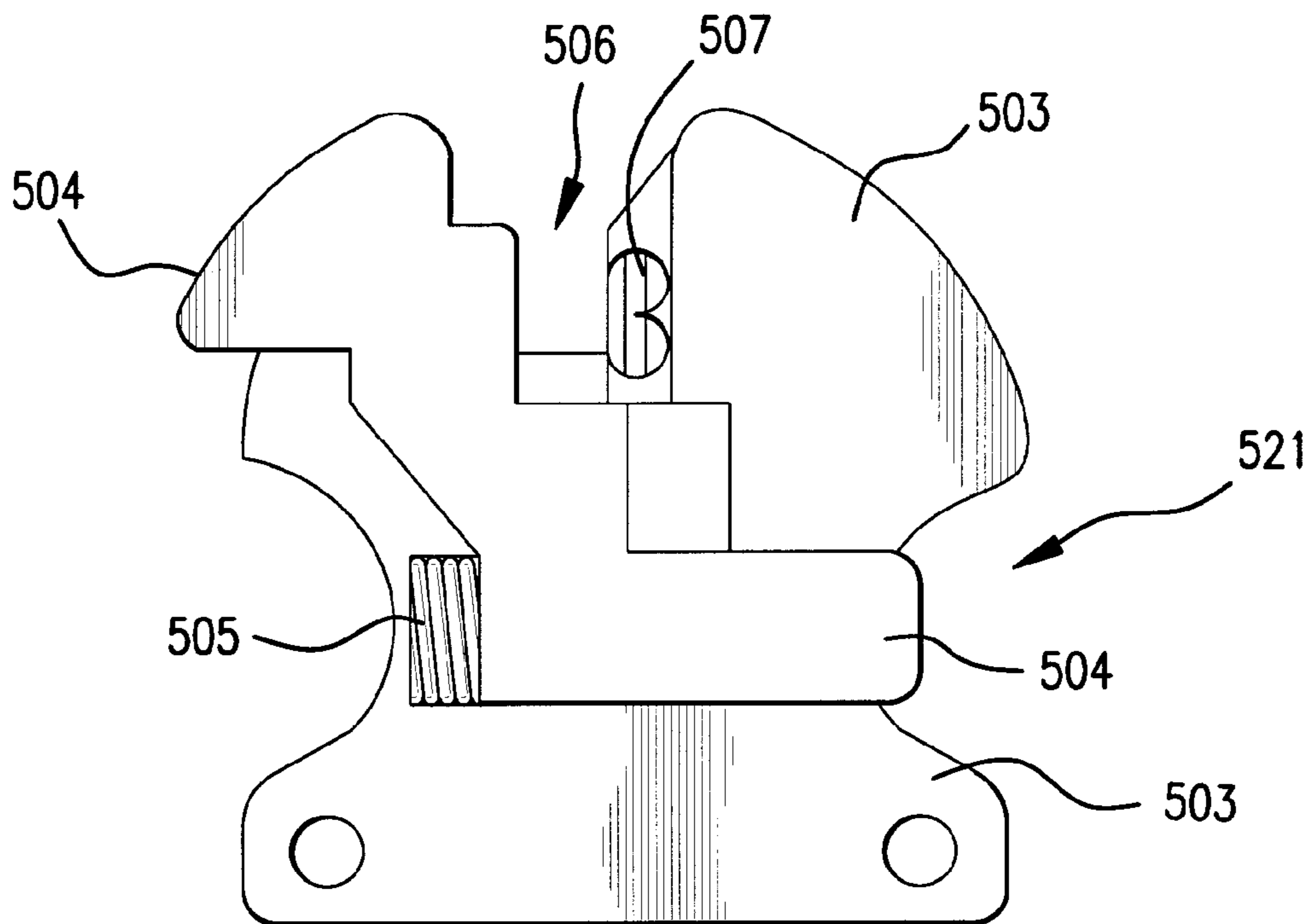

FIG. 17B

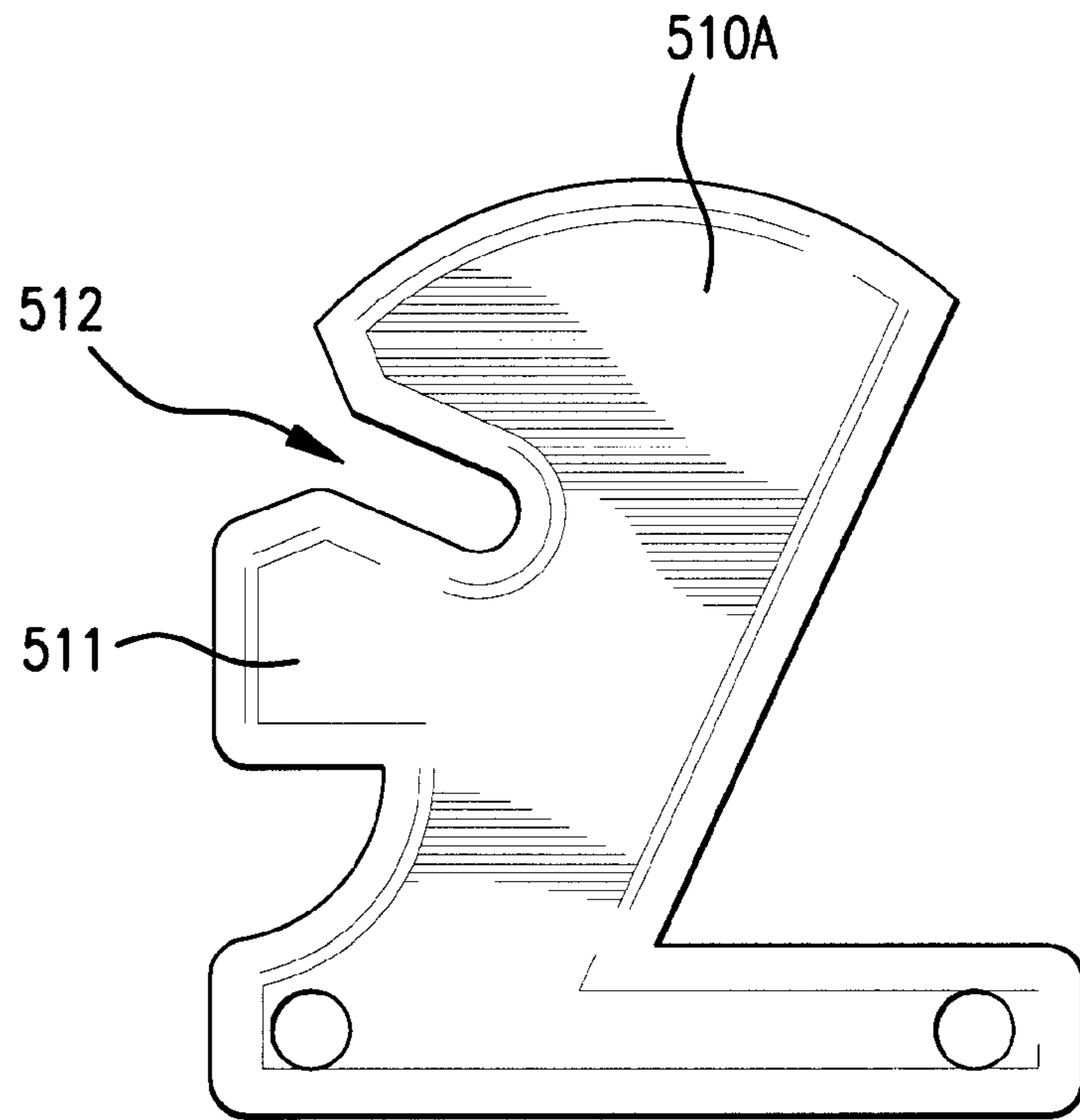

FIG. 18A

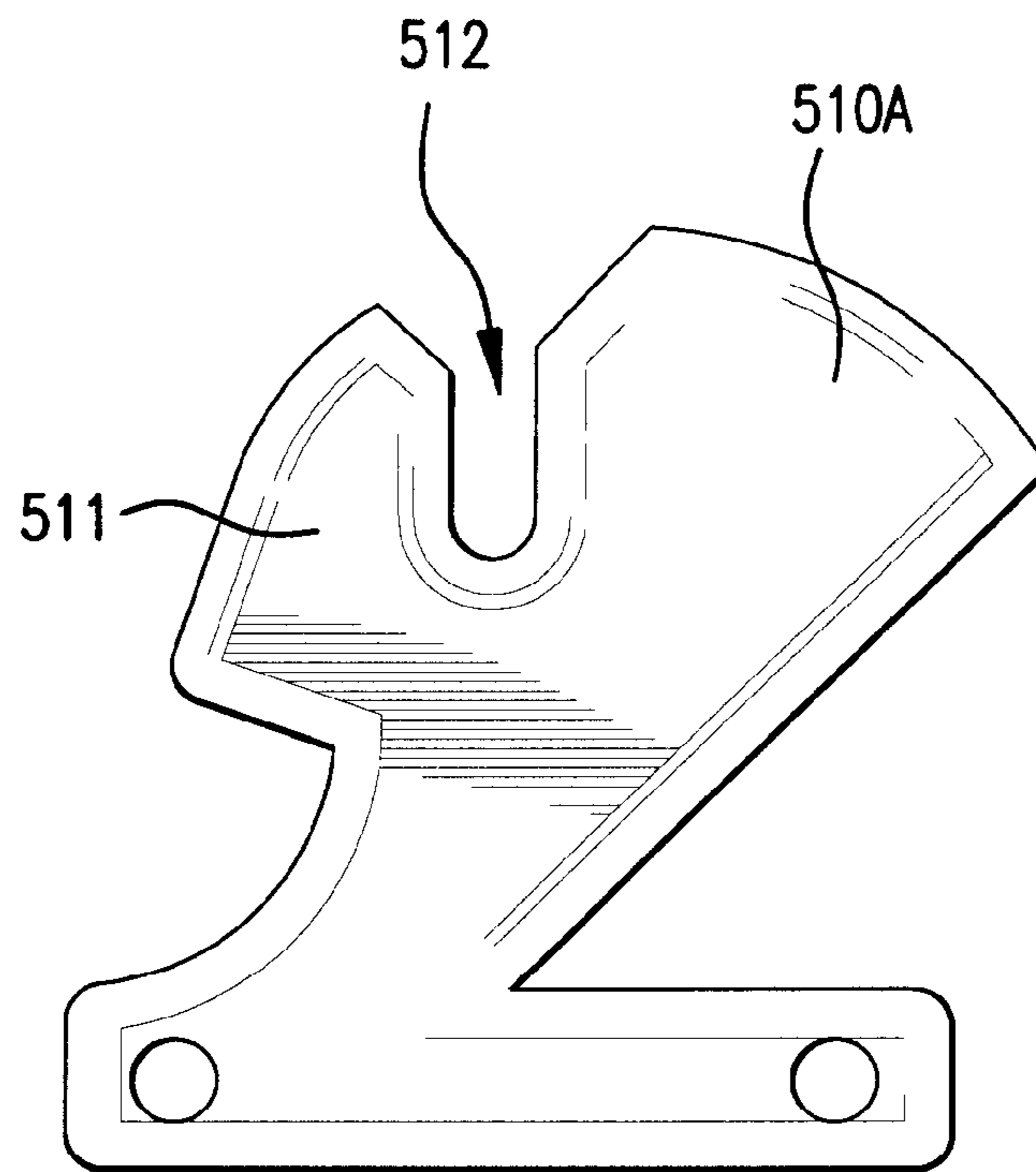

FIG. 18B

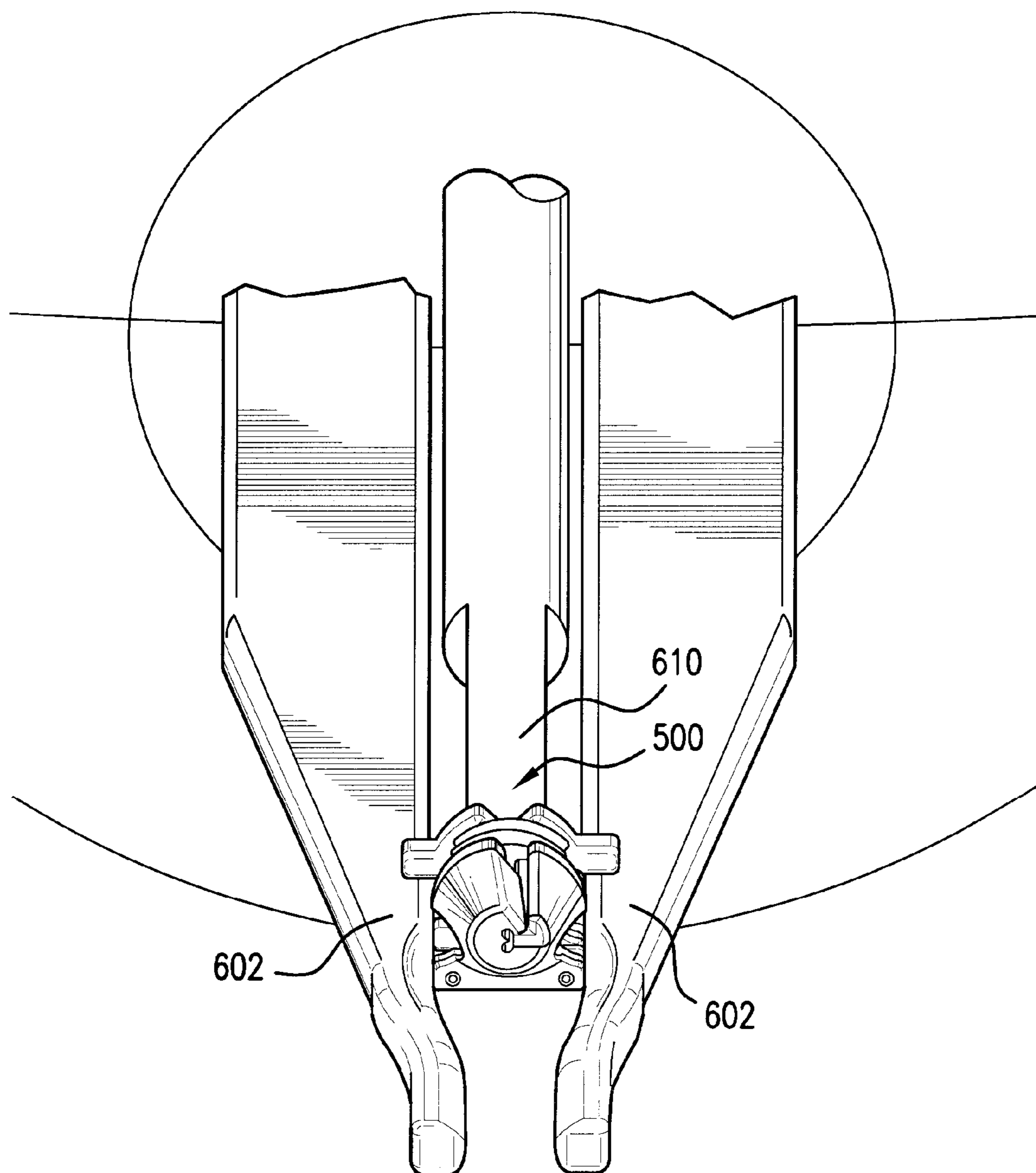

FIG. 19

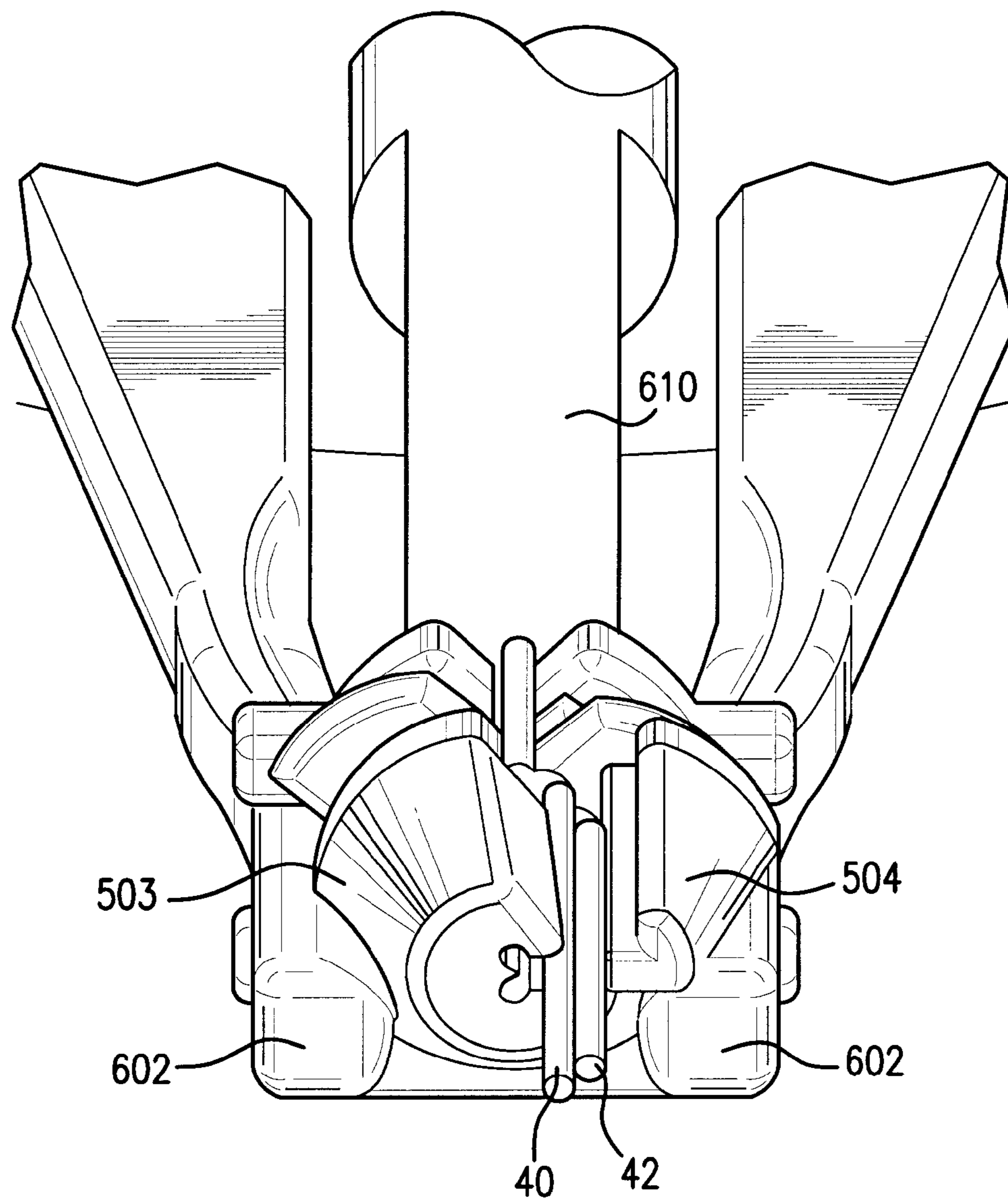

FIG. 20

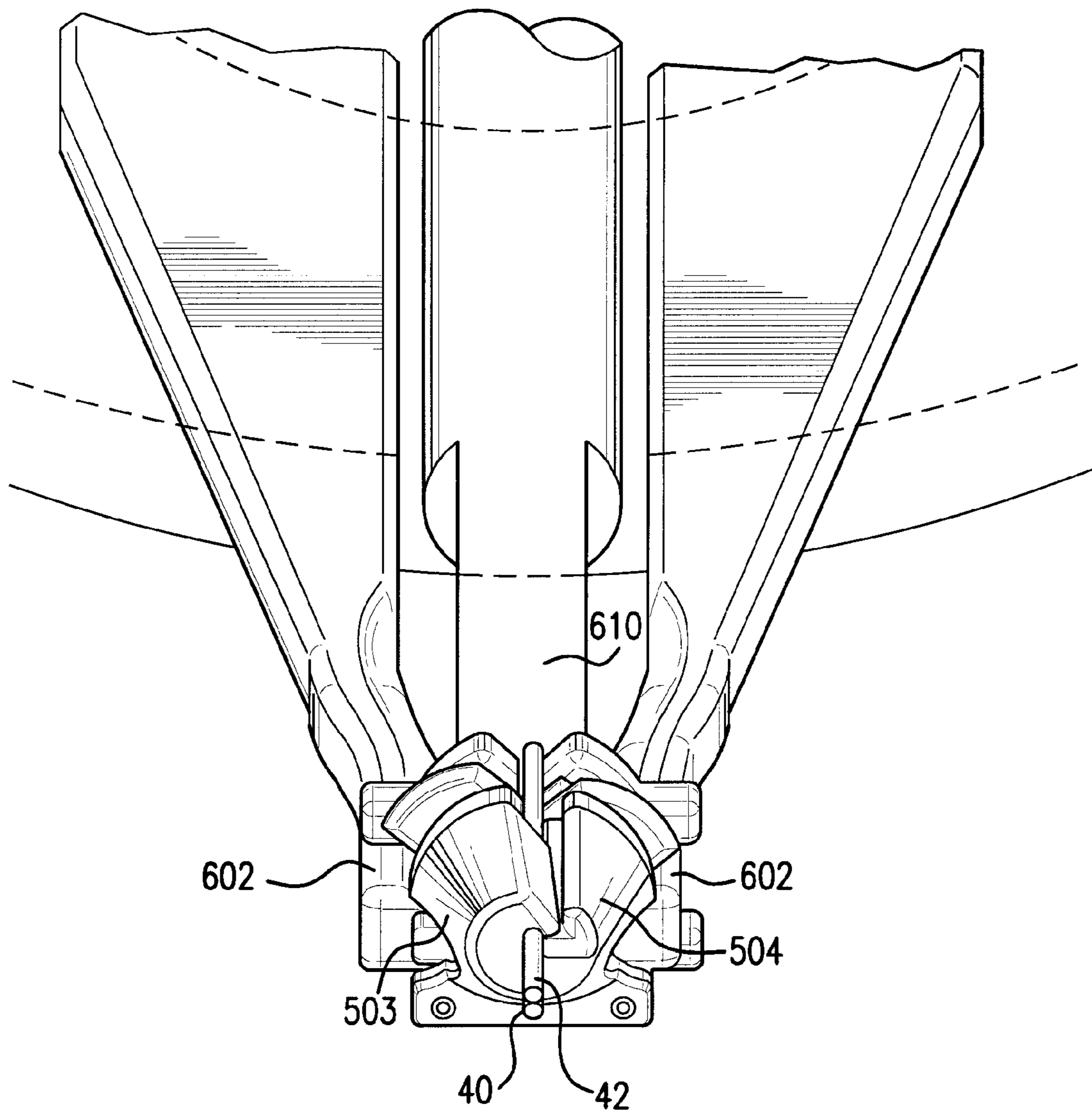

FIG. 21

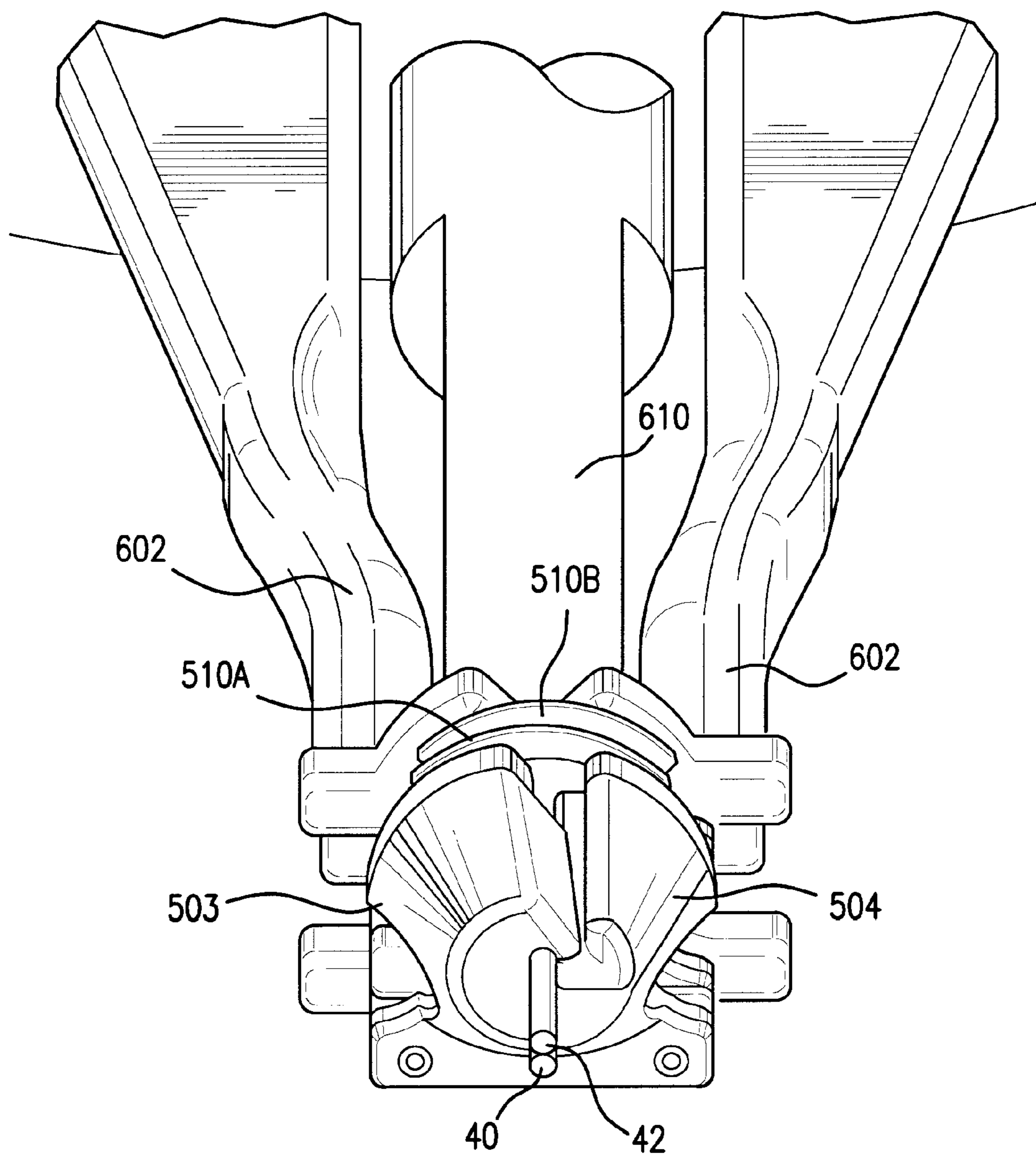

FIG. 22

**MULTI-ELEMENT BIASED SUTURE CLIP****CROSS-REFERENCE TO RELATED APPLICATIONS**

This is a continuation application of U.S. patent application Ser. No. 10/305,923, filed Nov. 26, 2002, now U.S. Pat. No. 7,108,710 and entitled "Multi element Biased Suture Clip", the disclosure of which is incorporated herein by this reference.

**BACKGROUND OF THE INVENTION****1. The Field of the Invention**

The present invention relates to systems for securing a pair of suture lengths together or for using a single strand of suture to secure tissues together at an operative site in a patient without necessarily tying a knot.

**2. The Relevant Technology**

Sutures are used to sew tissue together, and thereby close tissue openings, cuts or incisions during or after any of a very wide variety of medical procedures. Typically, the surgeon manually ties together a suture pair to close the opening, however, automatic suture tying systems have also been developed.

There are a number of disadvantages of knotting sutures together to secure tissues to one another. For example, manual knot tying requires considerable dexterity. Also, manual knot tying can take considerable time. Knot tying is further complicated by the fact that surgical sutures have low friction surfaces. Therefore, it is typically necessary for a surgeon to include many "throws" when tying the knot. This multiple-throw problem occurs even if an automatic knot tying device is used. Unfortunately, as the number of loops or "throws" incorporated into the knot increase, the knot becomes increasingly large and bulky. Moreover, the surgeon typically needs to handle strands of adequate suture length prior to commencing manual knot tying. Thus, manual knot tying requires considerable space both in which to view, and to perform, the actual suture knot tying. Therefore, knot tying is particularly difficult in areas of limited available space or access, such as, for example, at the back of the patient's heart during a coronary artery bypass graft (CABG) operation, or at the artery in the tissue tract after a femoral artery catheterization procedure. Manually tied knots often lock prior to reaching the intended amount of tension to be applied to the tissue. Furthermore, tissues are typically secured together by a pair of sutures wherein each of the sutures in the pair pass through both of the tissues which are then secured together by tying off the suture pair. It would instead be advantageous to provide a system which is adapted to secure tissue with suture, but without necessarily tying a knot.

**BRIEF SUMMARY OF THE INVENTION**

Embodiments of the present invention provide a suture clamping system. The present suture clamping system can be used to clamp a suture pair, or to use a single strand of suture to secure tissues together. In one embodiment, a plurality of elements define a slot sized to accept a suture element through the row of elements when at least one of the elements is in a first position, and wherein a tortuous path is formed through the row of elements when at least one of the elements is in a second position.

In various embodiments, the slot is generally parallel to the length of the row. In various embodiments, the at least one of the elements is a flexible element which is in the second

position when not biased, and which moves into the first position when biased. In various embodiments, the direction in which the flexible element is biased is generally transverse to the length of the row.

In various embodiments, the present invention comprises a plurality of adjacent flexible elements connected together in a row. The elements are biased to first positions which define an opening slot along the row of elements. A tortuous path is formed through the elements when the elements are not biased.

Still other embodiments may also include a biasing/positioning device which is used to bias and hold the row of elements in the first position (at which time an opening is defined along the top of the row for receipt of the suture length or suture pair therein). Preferably, the biasing device is slidably received around the row of elements such that as the biasing force is removed, (e.g.: as the row of elements are slidably pushed or otherwise advanced through the biasing device), the elements then move to a non-biased position (at which time a tortuous path is formed along through the row of elements). Thus, a suture pair can effectively be clamped or "fastened" together when the sutures are held in such a tortuous path. Features of the present invention allow a physician to completely avoid manual suture knot tying. Therefore, the bulky multiple loops or "throws" required when knot tying can be minimized or eliminated. Instead, the suture pair is simply "clamped" or held together between the flexible elements.

Alternatively, the present system can be clamped onto a single suture and can thus act as an anchor preventing movement of a tissue layer along a single suture strand. Specifically, when using only a single strand of suture, the suture is clamped so that it does not move with respect to the clamping system.

**BRIEF DESCRIPTION OF THE DRAWINGS**

FIG. 1 is a perspective view of a single flexible element.

FIG. 2 is a perspective view of row of flexible elements as individually illustrated in FIG. 1, with the elements in a non-biased position, forming a tortuous path therethrough.

FIG. 3 is an end view of the row of flexible elements as illustrated in FIG. 2.

FIG. 4 is a perspective view of row of flexible elements as individually illustrated in FIG. 1, with the elements biased into a first position such that an opening slot forms along the top of the row.

FIG. 5 is a perspective end view of the row of flexible elements as illustrated in FIG. 4.

FIG. 6 is an end elevation view of the row of flexible elements as illustrated in FIGS. 4 and 5.

FIG. 7 is a perspective view of an alternate design of a row of flexible elements, with the elements in a non-biased position, forming a tortuous path therethrough.

FIG. 8 is a perspective view of the row of elements of FIG. 7, with the elements biased into a first position such that an opening slot forms along the top of the row.

FIG. 9 is a perspective end view of a dual rail biasing device slidably received over the row of flexible elements, with the elements in a non-biased position, as shown in FIGS. 2 and 3.

FIG. 10 is in a view similar to FIG. 9, but including as suture pair received in the slot formed through the row of elements.

FIG. 11 is a perspective end view of the row of flexible elements after it has been pushed fully through the dual rail

biasing device, such that the elements return to a non-biased position, trapping the suture pair in a tortuous path therein, as shown in FIGS. 2 and 3.

FIG. 12 is a top plan view corresponding to FIG. 11.

FIG. 13 is an exploded perspective view of an embodiment of the invention having two non-flexible elements with a single flexible element positioned therebetween.

FIG. 14 is a perspective view of an embodiment of the invention further comprising a suture guide assembly, a pair of flexible suture capture elements and a rail guide.

FIG. 15 is an exploded perspective view of the invention shown in FIG. 14.

FIG. 16A is a front elevation view of the embodiment of the invention shown in FIG. 14 in a closed position.

FIG. 16B is a front elevation view of the embodiment of the invention shown in FIG. 14 in an open position.

FIG. 17A is a rear view of the suture guide assembly in a closed position (corresponding to FIG. 16A).

FIG. 17B is a rear view of the suture guide assembly in an open position (corresponding to FIG. 16B).

FIG. 18A is a front view of a pair of suture capture elements in a non-biased position.

FIG. 18B is a front view of a pair of suture capture elements in a biased position, thus forming a suture opening there-through.

FIG. 19 is a top perspective view of the device of FIG. 14, positioned on a pair of rails prior to deployment.

FIG. 20 is a view similar to FIG. 19, but with the device advanced to a position such that the rails cause the device to open to receive a suture pair therein.

FIG. 21 is a view similar to FIG. 20, but with the device advanced to a position such that the suture guide assembly projects beyond the distal ends of the rails, showing the suture guide assembly locking onto the suture pair.

FIG. 22 is a view similar to FIG. 21, but with the entire device advanced beyond the distal ends of the pair of rails, showing the suture capture elements locking onto the suture pair.

#### DETAILED DESCRIPTION

In accordance with the present invention, a suture clamping system is provided. In preferred aspects, the suture clamping system comprises a plurality of individual flexible elements positioned together in a row. In various preferred embodiments, the individual flexible elements are shaped the same. Optionally, the row of elements is formed by positioning successive identically shaped elements adjacent to one another. It is to be understood, however, that the individual elements in the row need not be identical in shape to one another. It is also to be understood that the individual elements need not be positioned in direct "touching" contact side-by-side with one another, but may instead be positioned some distance apart from one another. As will also be explained, various embodiments of the invention may include rows of elements including both flexible and non-flexible elements. In fact, in one embodiment, only one flexible element is required.

One or more of these elements are preferably biased in a direction transverse to the length of the row. When biased, one or more flexible elements move to a first position at which the elements define a slot along the length of the row. The slot is specifically sized to receive a suture therein. When not biased, the one or more flexible elements return to a second (non-biased) position. When in a non-biased position, the elements form a tortuous path for the suture received therein.

FIGS. 1 to 6 illustrate a first preferred embodiment of the present invention, and FIGS. 7 and 8 illustrate a second preferred embodiment of the present invention. FIGS. 9 to 12 illustrate an exemplary positioning/biasing device for use with various embodiments of a suture clamp. FIG. 13 illustrates an embodiment of the invention having only one flexible element. FIGS. 14 to 18B show component parts of an embodiment of the device having a suture guide assembly, a pair of flexible suture capture elements, and a rail guide. FIGS. 19 to 22 show sequential steps in the deployment of the embodiment of the device shown FIGS. 14 to 18B.

FIG. 1 illustrates an embodiment of a single clamping element 10. Element 10 has a lower portion 11, a neck 12, and an upper portion 13. A slot 14 is defined by upper portion 13. Also, an optional projection 15 extends longitudinally from upper portion 13. As will be explained, projections 15 provide contact surfaces between adjacent elements such that the elements may rest against one another when in a non-biased (second) position. It is to be understood that projections 15 are optional and that various embodiments of the present invention do not require projections 15 to operate.

Element 10 is preferably fabricated from a unitary block of Nitinol or other suitable flexible or elastic material, including various plastics and metals. Photochemical machining or other known techniques may be used to form element 10. Most preferably, each element 10 will be dimensioned to about 1 mm in height.

As can be seen in FIGS. 2 and 3, a plurality of flexible elements 10 (i.e.: 10A, 10B, 10C, 10D, etc.) can be positioned side-by-side forming row 20. Preferably, lower portions 11 of the successive elements 10 are positioned adjacent to one another such that their projections 15 interlock with upper portions 13 of adjacent elements (as shown in FIG. 2). Lower portions 11 of the successive elements 10 may optionally be connected together (side-by-side) by a variety of techniques, including fusion bonding and adhesives. Alternatively, lower portions 11 of the successive elements 10 may optionally be spaced some distance apart from one another (not shown).

In another embodiment, elements 10 may each optionally comprise a pair of holes 16 (see FIG. 1) such that elements 10A, 10B, 10C, 10D, can be positioned on rods 30 and 32, or a similar mounting element or structure.

In accordance with the present invention, a biasing force ("F" in FIG. 3) is applied to the upper portions of each of elements 10. Biasing force F is applied in a direction generally transverse to the length of the row. Thus, as can be seen, force F will squeeze row 20 from its sides. The bottom portions 11 of each of elements 10 are held in a constant position with respect to one another. Alternatively, an embodiment of the present invention may include a single unitary bottom portion (as opposed to the illustrated plurality of separate bottom portions 11). Thus, the device which comprises the row of elements can be machined or molded out of a solid block of material such that the elements have a common bottom portion (for example, as illustrated in FIG. 13). Having a thin neck 12, the upper portions 13 of each of elements 10 will tend to move apart in a direction transverse to the row of elements as biasing force F is applied.

As shown in FIGS. 4 to 6, when a sufficiently strong biasing force F is applied, elements 10 move to a first position in which a slot 22 forms along the top of row 20. (i.e. when adjacent slot defining features 14 in successive elements 10 are in alignment). At this time a pair of sutures 40 and 42 (see FIG. 10) can be positioned within slot 22. When force F is removed, elements 10 will naturally tend to return to their non-biased (or possibly biased against one another) position, at which time an upper portion 13A of a first element (10A)



5

will abut against projection 15B of upper portion 13B of a second element (10B), as shown in FIGS. 2 and 3.

The flexible elements which are used to form the suture clamping device can be made in a variety of different shapes. For example, referring to FIGS. 7 and 8, a row 200 of flexible elements 100A, 100B, 100C, 100D, 100E, etc. are used to form a suture clamping device. Specifically, as shown in the non-biased position (i.e. FIG. 7), elements 100 each have a lower portion 110, a neck 120 and an upper portion 130. Upper portion 130 has a slot defining features 140 formed therein. As can be seen, element 110 is formed such that its neck 120 holds upper portion 130 (and slot defining features 140) at an angle when in the non-biased (FIG. 7) position.

Thus, when a squeezing force F is applied against flexible elements 100 on either side of row 200, elements will be biased into the position shown in FIG. 8 wherein the slot-defining features 140 of successive elements are positioned in alignment with one another to form a slot 122. A pair of sutures 40 and 42 can then be placed into slot 122. When the biasing force F is released, elements 110 will tend to move back to the position shown in FIG. 7, thus forming a tortuous path for sutures 40 and 42, passing therethrough.

In an alternate embodiment, the elements are formed such that a suture slot is instead formed when the elements are in their non-biased position. In such an embodiment, the application of a biasing force would move the elements into a position such that the tortuous suture path is formed therethrough. After the elements have been biased to move into positions forming the tortuous suture path therethrough, a clip or other fastening device can be used to hold the elements in the biased position, with the tortuous suture path passing therethrough.

Sutures 40 and 42 may preferably comprise opposite ends of a continuous suture loop which has been used to suture together an anastomosis graft or to close a hole in a blood vessel or other tissue wall, or to anchor one or more suture elements. Alternatively, sutures 40 and 42 may comprise ends of separate suture strands which are fastened (i.e. clamped) together by present invention.

In accordance with preferred aspects of the present invention, a method for clamping a suture pair is also provided. Preferably, this method includes biasing the row of adjacent flexible elements 10 (i.e.: applying force F) so that elements 10 move to the position (as shown in FIGS. 4 to 6) in which an opening slot 22 is formed therethrough. Preferably, this biasing force is applied in a direction transverse to the length of the row. Then, suture pair 40 and 42 is received into opening slot 22. Then, biasing force F is removed such that the adjacent flexible elements 10A, 10B, 10C, 10D, etc., move to positions which hold the suture pair in a tortuous path (as shown in FIGS. 2 and 3). Similarly, as seen in FIGS. 7 and 8, the present method may comprise: biasing the row of adjacent flexible elements 100 (i.e.: applying force F) so that elements 100 move to the first position (as shown in FIG. 9) in which an opening slot 122 is formed there along. Then, suture pair 40 and 42 is received into opening slot 122. Then, biasing force F is removed such that the adjacent flexible elements 100A, 100B, 100C, 100D, etc., move or spring back to positions which hold the suture pair in a tortuous path (as shown in FIG. 7).

The present method will be explained by reference to a dual rail positioning/biasing device shown in FIGS. 9 to 12, as follows.

A biasing device 50 may be provided as part of the present suture clamping system. In one embodiment, biasing device 50 comprises two rails 51 and 52 which are parallel to one another over two regions, and angled with respect to one

6

another over another region. Specifically, as seen in FIG. 9, rails 51 and 52 are parallel with respect to one another in regions 54 and 58 and are angled with respect to one another in region 56. As also seen in FIG. 9, a push rod 60 is used to successively push elements 10A, 10B, 10C and 10D distally from region 58, and then through regions 56 and 54.

From the position shown in FIG. 9, push rod 60 is advanced such that row 20 of elements 10 is pushed into region 54 (as shown in FIG. 10) wherein rails 51 and 52 are positioned closer together, such that individual slot defining features 14 are put into alignment (forming slot 22 along the length of row 20). As shown in FIG. 10, a suture pair 40, 42 can then be positioned within slot 22. Lastly, as shown in FIGS. 11 and 12, row 20 is pushed out of the distal end of biasing device 50. As shown in FIG. 12, the biasing force on the sides of row 20 is removed such that elements 10A, 10B, 10C and 10D return to their non-biased position, thus forming a tortuous path for suture pair 40 and 42 passing therethrough.

As stated above, the present invention may comprise a plurality of flexible elements. It is to be understood, however, that embodiments of the invention may also comprise non-flexible elements, or various combinations of flexible and non-flexible elements. For example, as shown in FIG. 13, a row 300 of elements (which may optionally have a single unitary base 310) may have a single flexible element 300B disposed between (or otherwise adjacent to) non-flexible elements 300A and 300C. When a biasing force F is applied to the sides of the device, flexible element 300B will move to a position such that elements 300A, 300B and 300C will be placed in alignment. Then, a suture, or suture pair can easily be threaded through opening slots 340A, 340B and 340C. When biasing force F is removed, element 300B will tend to spring back into the position shown in FIG. 13, thereby forming a tortuous path, firmly holding the suture(s) therein.

FIGS. 14 to 18B show an alternate embodiment of the present invention that includes a suture clamp assembly 500 including a suture guide assembly 502, a pair of flexible elements 510A and 510B and a rail guide 520. Suture guide assembly 502 includes a suture guide 503 and a suture lock 504. As can be seen in FIGS. 16A to 17B, suture lock 504 is movable with respect to suture guide 503, thus permitting a suture or suture pair to be inserted therebetween, and then clamped, as follows. As shown in FIGS. 16A and 17B, suture lock 504 is initially position adjacent to suture guide 503 (by the action of spring 505). When using the device, the end of suture lock 504 which extends in to cavity 521 in rail guide 520 is pushed. Such force compresses spring 505 so that suture lock 504 moves to the position shown in FIGS. 16B and 17B, thereby opening passageway 506, permitting a suture, or suture pair to be inserted therein. Thereafter, the force can be removed from the end of suture lock 504 which extends in to cavity 521 such that, spring 505 expands and suture lock 504 returns to the position shown in FIGS. 16A and 17A, thereby trapping a suture or suture pair in passageway 506.

Behind suture guide assembly 502 are positioned one or more flexible elements which are used to capture a suture or suture pair. These flexible elements operate in the same manner as the "row of flexible elements" described with regard to other embodiments herein. Specifically, flexible elements 510A and 510B have a non-biased position as shown in FIG. 18A. When a biasing force is applied to the underside of projections 511, flexible elements 510A and 510B move to the positions shown in FIG. 18B, at which time their slots 512 move into alignment with one another. When slots 512 of flexible elements 510A and 510B are positioned in alignment, a suture or suture pair can be received therein. Then, the

biasing forces can be removed from projections **511**, causing the flexible elements to move towards the position shown in FIG. **18A**, thereby forming a tortuous path for a suture passing therethrough. It is to be understood that the present invention encompasses embodiments with more than two flexible suture capture elements **510**, or even as few as one flexible and one non-flexible element.

In optional preferred aspects, both the suture guide **503** and the suture lock **504** are dimensioned such that the opening slot **507** (formed in passageway **506** in which the suture(s) are trapped) is not co-linear with the opening slots **512** through flexible elements **510A** and **510B**. An advantage of opening slot **507** not being co-linear with the path through opening slots **512** is that this further adds to the tortuosity of the suture path through the device, and permits more exact positioning of the device with respect to the target tissue.

FIGS. **19** to **22** show the deployment of the embodiment of the invention shown in FIGS. **14** to **18B**, as follows. As shown in FIG. **19**, suture clamp assembly **500** is initially positioned between rails **602**, with a push rod **610** abutting against the rear of rail guide **520**. Next, push rod **610** is used to advance the suture clamp assembly **500** to the position shown in FIG. **20** where the spacing between rails **602** narrows. Thus, one of the rails **602** will push on the end of suture lock **504** in cavity **512** so that suture lock **504** moves apart from suture guide **503**, as explained above. In addition, advancing flexible elements **510A** and **510B** to the region where the spacing of rails **602** narrows will move flexible elements **510A** and **510B** to their biased position (FIG. **18B**). At this time, a pair of sutures **40** and **42** can be received therein. Next, push rod **610** is used to advance the suture clamp assembly **500** to the position shown in FIG. **21** where suture guide assembly **502** is advanced beyond the distal end of the rails **602**. Accordingly, suture lock **504** moves back into position against suture guide **503**, thereby trapping sutures **40** and **42** therebetween. Lastly, as shown in FIG. **22**, push rod **610** is used to fully push assembly **500** out beyond the distal end of rails **602**. At this time, flexible elements **510A** and **510B** spring back to their non-biased positions, thus forming a tortuous path for sutures **40** and **42** passing therethrough. Accordingly, the row of flexible elements **510A** and **510B** assist suture guide assembly **502** in clamping onto sutures **40** and **42**, thereby operating as a system which fastens the sutures together. In accordance with this embodiment of the invention, the suture guide assembly **502** fastens onto the suture (or suture pair) prior to flexible elements **510A** and **510B** fastening onto the suture(s). The suture guide assembly **502** can be positioned immediately adjacent to the tissue target site, if desired. After the suture guide assembly **502** has clamped onto the suture(s), the flexible elements **510A** and **510B** will sequentially clamp onto the suture(s), thereby taking up any slack in the suture(s) from the proximal side of the device. In other words, as each of the elements in the row of flexible elements is sequentially pushed out from between rails **602**, the flexible elements will sequentially move to their non-biased positions, drawing in suture through rail guide **520**. Since the suture is pulled in from the rail guide (i.e. the proximal) end of the device, it will not pull on the suture(s) from the suture guide assembly (i.e. the distal) end of the device. This minimizes inadvertent pulling on the sutures at the target tissue location (i.e. at the distal) end of the device).

The present system can be positioned directly adjacent to the operative site at which it is desirable to secure the suture pair. Specifically, the present system can be deployed without pulling suture at the surgical site as the suture pair is secured together. Rather, in preferred embodiments, as the present system is deployed, it pulls in suture from end of the clamp

positioned away from the operative site. In contrast, manual or even automatic knot tying systems may either result in a loose knot being positioned at a small distance away from the operative site, or an overly tight knot pulling excessively on the tissues.

In addition, the present system can minimize the extent to which suture at the surgical site is pulled as it secures the suture(s). As the present system is deployed, it simply tightens together a suture pair at the operative site. In contrast, when tying together a suture pair, it is typically difficult to tie a knot very close to the operative site without excessively pulling on the tissues being tied together.

The present invention may be embodied in other specific forms without departing from its spirit or essential characteristics. The described embodiments are to be considered in all respects only as illustrative and not restrictive. The scope of the invention is, therefore, indicated by the appended claims rather than by the foregoing description. All changes which come within the meaning and range of equivalency of the claims are to be embraced within their scope.

What is claimed is:

**1.** A suture clamp comprising a plurality of individual elements positioned together in a row, each individual element comprising a lower portion, a flexible neck extending from the lower portion, and an upper portion having a slot, the plurality of slot portions of the plurality of individual elements defining a slot sized to accept a suture element through the row of individual elements when the individual elements are biased into a first position with the plurality of slot portions longitudinally aligned, the flexible necks of adjacently positioned individual elements moved towards one another in a direction transverse to the longitudinal slot and the upper portions of adjacently positioned individual elements moved apart in the direction transverse to the longitudinal slot, the plurality of slot portions define a tortuous path for the suture element when at least one of the individual elements is unbiased to a second position with a portion of the upper portion of one individual element resting against the upper portion of an adjacently positioned individual element and the flexible necks of adjacently positioned individual elements being moved away from one another in the direction transverse to the longitudinal slot, the tortuous path preventing passage of the suture through the slot portions of adjacently positioned separate elements.

**2.** The suture clamp according to claim **1**, wherein one or more of the individual elements are flexible.

**3.** The suture clamp according to claim **1**, wherein the suture clamp is constructed of nitinol.

**4.** The suture clamp according to claim **1**, wherein the plurality of elements are bonded together to form a single suture clamp.

**5.** The suture clamp according to claim **1**, wherein the plurality of individual elements are sized to receive a second suture element therethrough.

**6.** The suture clamp according to claim **5**, wherein the first and second suture elements comprise ends of a suture loop.

**7.** The suture clamp according to claim **1**, wherein the plurality of separate elements are generally identically shaped.

**8.** A suture clamp comprising a plurality of separate modular, non-integrally formed elements positioned adjacently together in a row, each separate modular element comprising an upper portion having a slot adapted to receive a suture element, a flexible neck extending from the upper portion, and a lower portion extending from the flexible neck, the plurality of slots of the plurality of separate modular elements configured to accept the first suture element through the row

of separate modular elements when the separate modular elements are biased to a first position with the plurality of slots being longitudinally aligned, the flexible necks of adjacently positioned separate modular elements moved towards one another in a direction transverse to the longitudinal slot and the upper portions of adjacently positioned separate modular elements moved apart in the direction transverse to the longitudinal slot, the plurality of slots define a tortuous path for the first suture element when at least one of the separate modular elements is unbiased in a second position where the upper portions of adjacent separate modular elements are moved toward one another in the direction transverse to the longitudinal slot, the tortuous path preventing passage of the suture through the slots of adjacently positioned separate elements.

9. The suture clamp according to claim 8, wherein the flexible element is in the first position when biased.

10. The suture clamp according to claim 8, wherein the suture clamp is constructed of nitinol.

11. The suture clamp according to claim 8, wherein the plurality of elements are bonded together to form a single suture clamp.

12. The suture clamp according to claim 8, wherein the plurality of elements are sized to receive a second suture element therethrough.

13. The suture clamp according to claim 12, wherein the first and second suture elements comprise ends of a suture loop.

14. The suture clamp according to claim 8, wherein the plurality of separate elements are generally identically shaped.

15. A method of clamping a suture passing through a tissue layer with a suture clamp system comprising a plurality of separate, non-integrally formed elements positioned together in a row along a pair of rods, each separate element comprising an upper portion having a slot portion, the separate element further including a flexible neck extending from the upper portion to a lower portion, wherein the separate elements are such that when at least one of the separate elements is biased into a first position, the plurality of slot portions of the plurality of separate elements define a slot to accept a suture is formed through the row of individual elements, and the plurality of slot portions defining a tortuous path through

the separate elements when the separate elements are not biased, the tortuous path preventing passage of the suture through the slot portions of adjacently positioned separate elements, the method comprising:

5 applying a biasing force to the at least one separate element to bias at least one separate element into the first position from a second position, the first position having the slot portion of the at least one separate element longitudinally aligned with the slot portion of an adjacently positioned another at least one separate element, the flexible necks of adjacently positioned separate elements moved towards one another in the direction transverse to the longitudinal slot, the upper portions of adjacently positioned separate elements moved apart in the direction transverse to the longitudinal slot, the second position having the separate elements defining the tortuous path and preventing passage of the suture through the slot portions of adjacently positioned separate elements, passing the suture through a tissue layer, receiving the suture into the slots of the plurality of separate elements, and removing the biasing force to move the at least one separate element to form the tortuous path to secure the suture passing through the slot portions of the plurality of separate elements within the suture clamp system and to move the upper portion of the at least one separate element toward the upper portion of an adjacently positioned separate element in the direction transverse to the longitudinal slot.

16. The method according to claim 15, wherein the biasing step comprises using a biasing device to bias the at least one separate element.

17. The method according to claim 16, wherein the receiving step comprises receiving two sutures into the slot.

18. The method according to claim 15, wherein the biasing step comprises biasing in a direction transverse to a length of the row.

19. The method according to claim 15, further comprising securing the row of separate elements to the suture.

20. The method according to claim 15, wherein the step of removing the biasing comprises slidably advancing the row of separate elements through a biasing device.

\* \* \* \* \*