



US007805842B2

(12) **United States Patent**
Bland

(10) **Patent No.:** **US 7,805,842 B2**
(45) **Date of Patent:** **Oct. 5, 2010**

(54) **SCISSORS WITH AN INTEGRATED TAPE DISPENSER**

2,023,408 A * 12/1935 Coll 30/134
2,023,409 A * 12/1935 Coll 30/123
2,136,769 A * 11/1938 Witchger 33/767

(75) Inventor: **Michael Scott Bland**, Atlanta, GA (US)

(73) Assignee: **Bon Mots, LLC**, Atlanta, GA (US)

(*) Notice: Subject to any disclaimer, the term of this patent is extended or adjusted under 35 U.S.C. 154(b) by 410 days.

(Continued)

FOREIGN PATENT DOCUMENTS

(21) Appl. No.: **11/974,375**

JP 02206492 A * 8/1990

(22) Filed: **Oct. 12, 2007**

(Continued)

(65) **Prior Publication Data**

US 2009/0095429 A1 Apr. 16, 2009

OTHER PUBLICATIONS

(51) **Int. Cl.**
B26B 13/22 (2006.01)

International Search Report and Written Opinion, both dated Dec. 24, 2008 issued in international application No. PCT/US2008/008912.

(52) **U.S. Cl.** **30/123; 30/232; 30/254; 225/7**

(Continued)

(58) **Field of Classification Search** **30/231, 30/232, 235, 236, 254, 123; 225/7; 7/160; D8/57**

Primary Examiner—Jason Daniel Prone
(74) *Attorney, Agent, or Firm*—Robert Z. Evora

See application file for complete search history.

(57) **ABSTRACT**

(56) **References Cited**

U.S. PATENT DOCUMENTS

140,227 A *	6/1873	Stubbings	30/254
346,583 A *	8/1886	Corbett	30/341
348,749 A *	9/1886	Kimble	30/226
389,553 A *	9/1888	Diefendorf	30/254
580,995 A *	4/1897	Thorlakson	30/146
643,377 A	2/1900	Janney	
752,339 A *	2/1904	Gutstein	30/341
D47,735 S *	8/1915	Piggott	D8/55
1,182,561 A *	5/1916	Hanscom	30/146
1,218,798 A *	3/1917	Nelson	30/254
1,223,640 A	4/1917	Sweet	
1,276,433 A	8/1918	Stainbrook et al.	
1,300,932 A	4/1919	Dingle	
1,436,948 A	11/1922	Dedio	
1,935,812 A *	11/1933	Moody	30/143

A combined scissors and tape dispenser configured as a unitary construction. The combined scissors and tape dispenser apparatus includes a pair of blades. A first blade includes a first elongated cutting member integrated with a first looped handle portion. A second blade is pivotally connected to the first blade. The second blade includes a second elongated cutting member integrated with a second looped handle portion. A dispenser reel including a cutting implement is integrated as part of at least one of the first looped handle portion and the second looped handle portion. The dispenser reel includes a through-hole adapted to be gripped by at least one of the user's fingers.

14 Claims, 12 Drawing Sheets

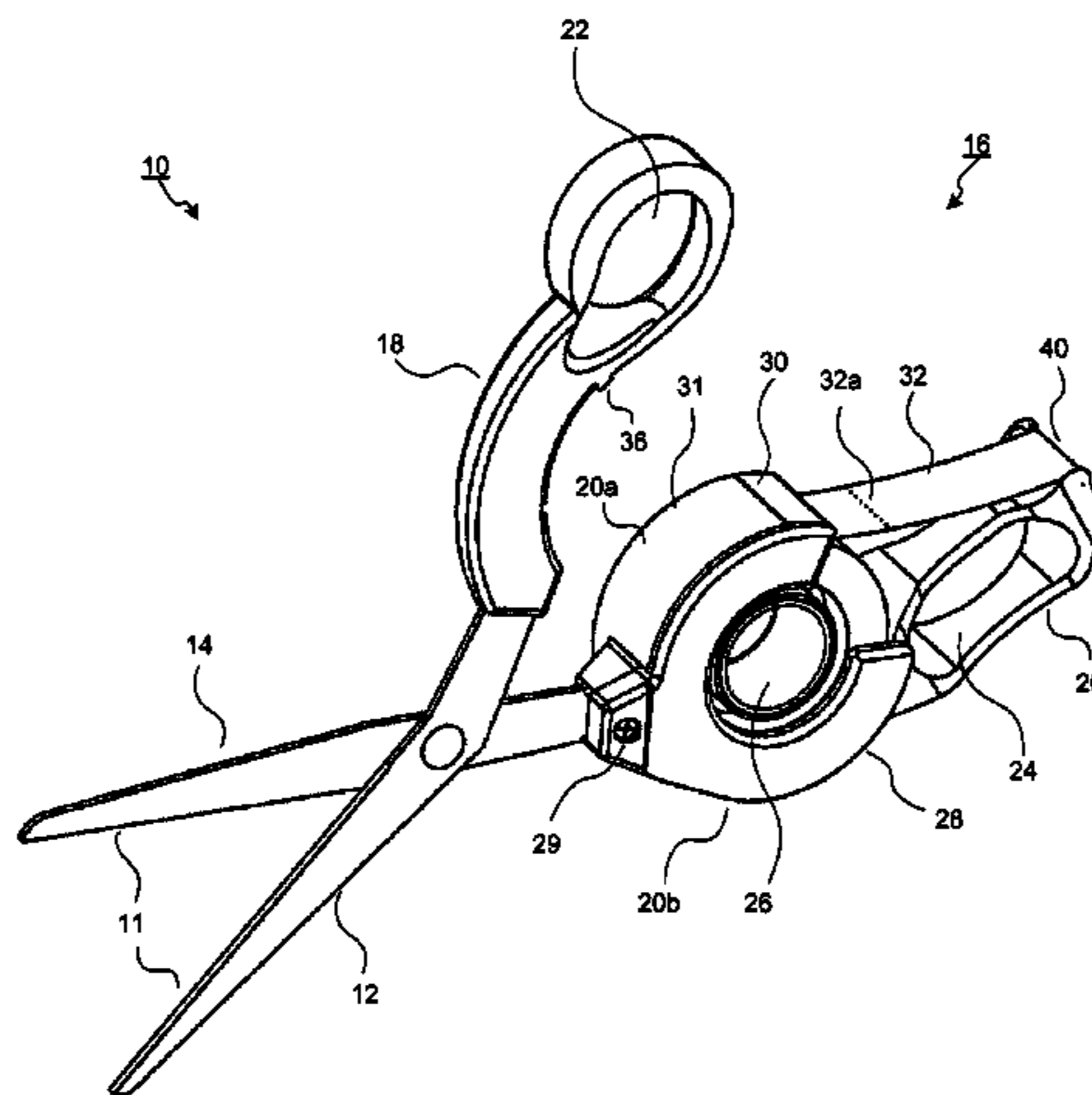

US 7,805,842 B2

Page 2

U.S. PATENT DOCUMENTS

2,159,060 A * 5/1939 Tuttle et al. 30/254
4,763,415 A 8/1988 Huang
4,783,867 A 11/1988 Tsao
5,539,994 A * 7/1996 Milden 33/760
6,272,754 B1 8/2001 Hesprich
6,286,745 B1 9/2001 Ackeret
6,523,264 B1 2/2003 Albert et al.
6,783,042 B2 * 8/2004 Kaufer 7/160
6,813,976 B2 * 11/2004 Malvini et al. 7/127
6,874,189 B2 4/2005 Ackeret
6,883,238 B1 4/2005 Tran
D505,054 S * 5/2005 McLean et al. D8/57
6,941,604 B2 * 9/2005 Ackeret 7/160
D532,269 S * 11/2006 Kaye D8/57
7,143,922 B2 12/2006 Shevin-Sandy
7,373,682 B2 * 5/2008 Cetera 7/160
7,591,037 B1 * 9/2009 Strickland 7/160

2003/0221320 A1 12/2003 Carpenter et al.
2005/0217032 A1 * 10/2005 Bruggisser 7/119
2007/0124866 A1 * 6/2007 Grepper 7/160
2010/0122419 A1 * 5/2010 Zupancic-Albin 7/125

FOREIGN PATENT DOCUMENTS

JP 2000-5464 A 1/2000
KR 20-0241869 Y1 10/2001
WO PCT/US2008/008912 4/2009

OTHER PUBLICATIONS

Advertisement for "Easy Glide Gift Wrapping Shears" printed on Feb. 11, 2010 from http://www.qvc.com/qic/qvcapp.aspx/view.2/app.detail/params.aol_refer.false.tpl.detail.msn_refer.false.item.V28091.ref.GBA?cm_ven=GOOGLEBASE&cm_cat=Sports%20&cm_pla=Crafts%20&cm_ite=V28091.

* cited by examiner

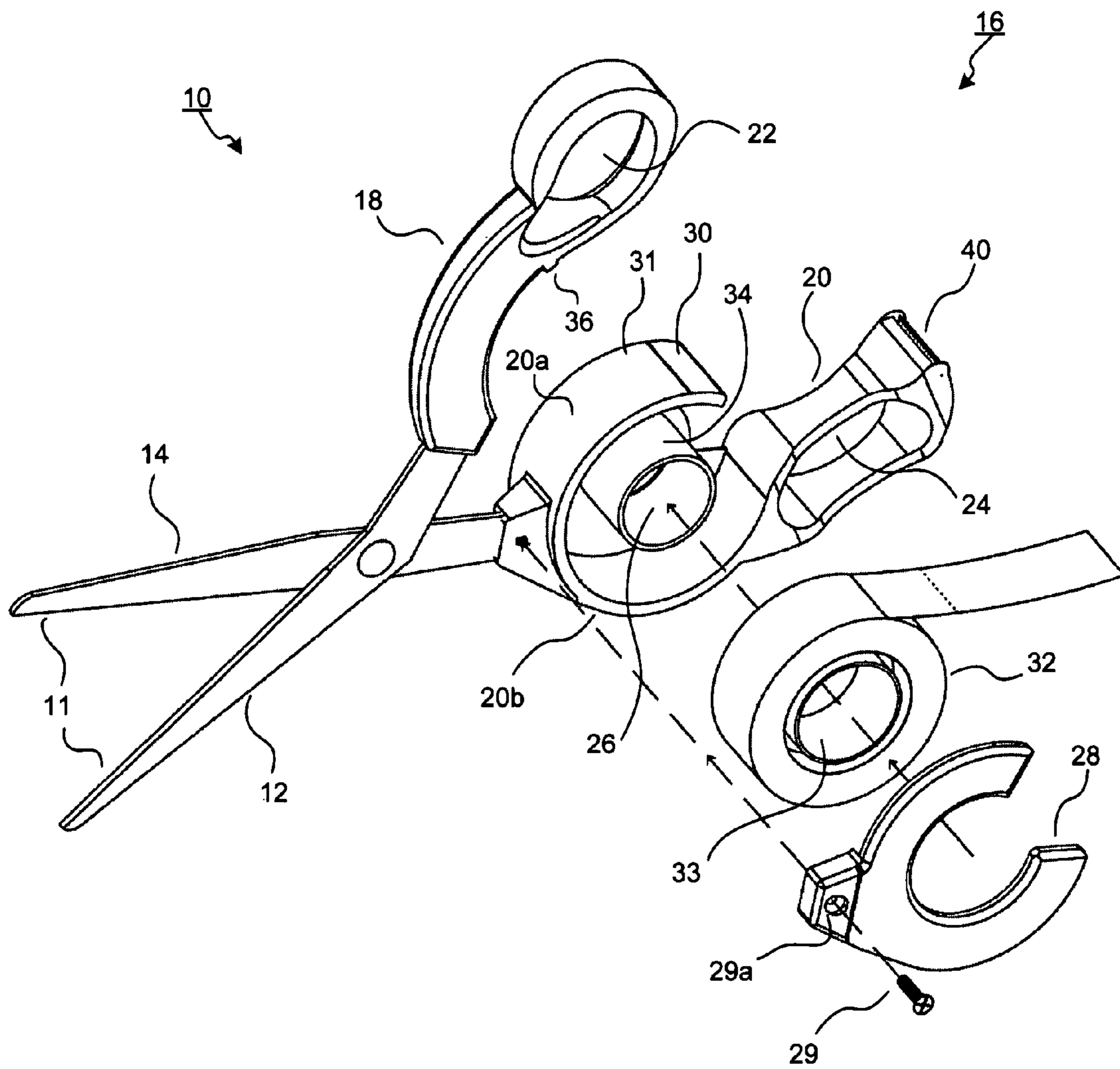

FIG. 1

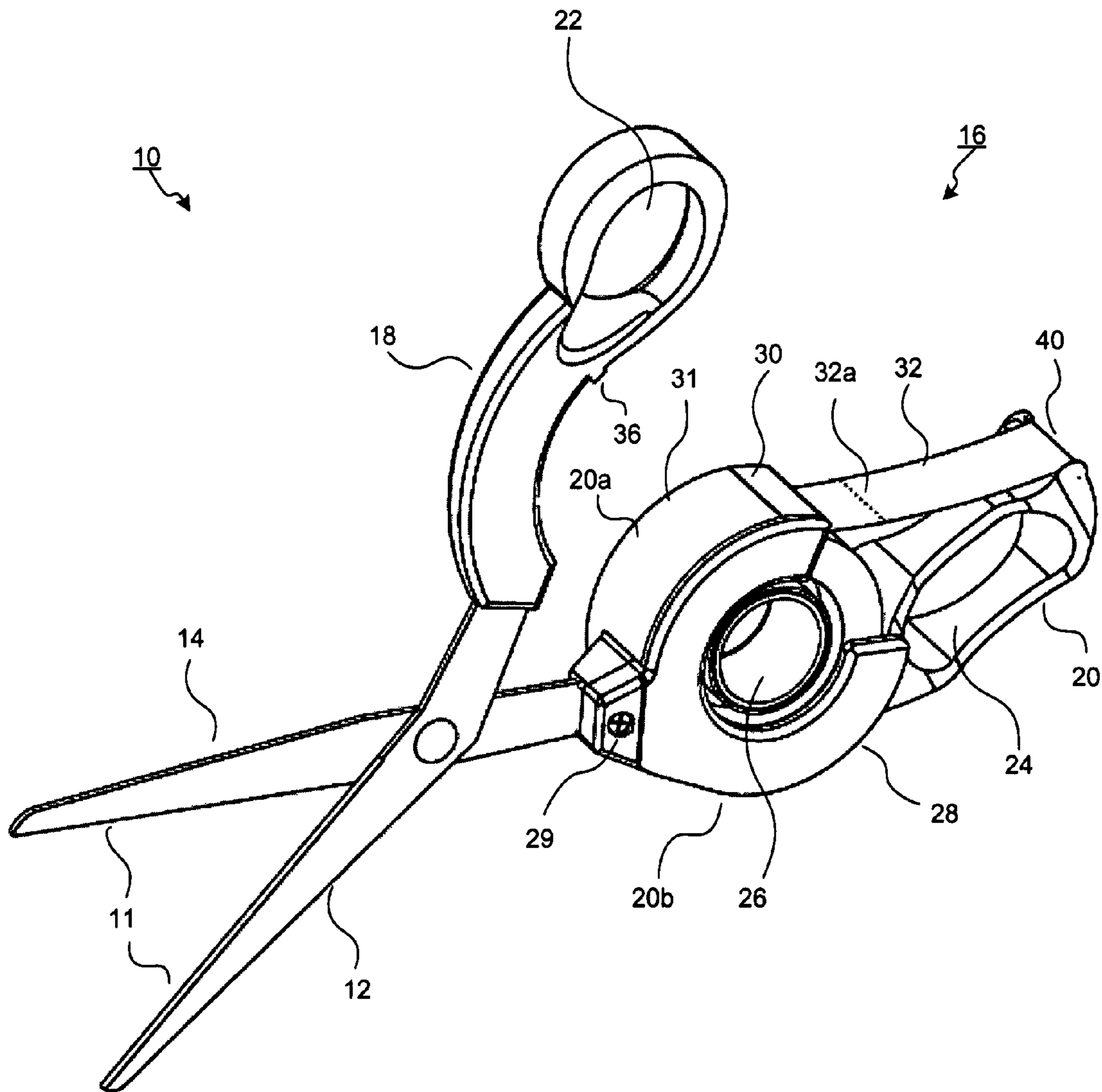

FIG. 2

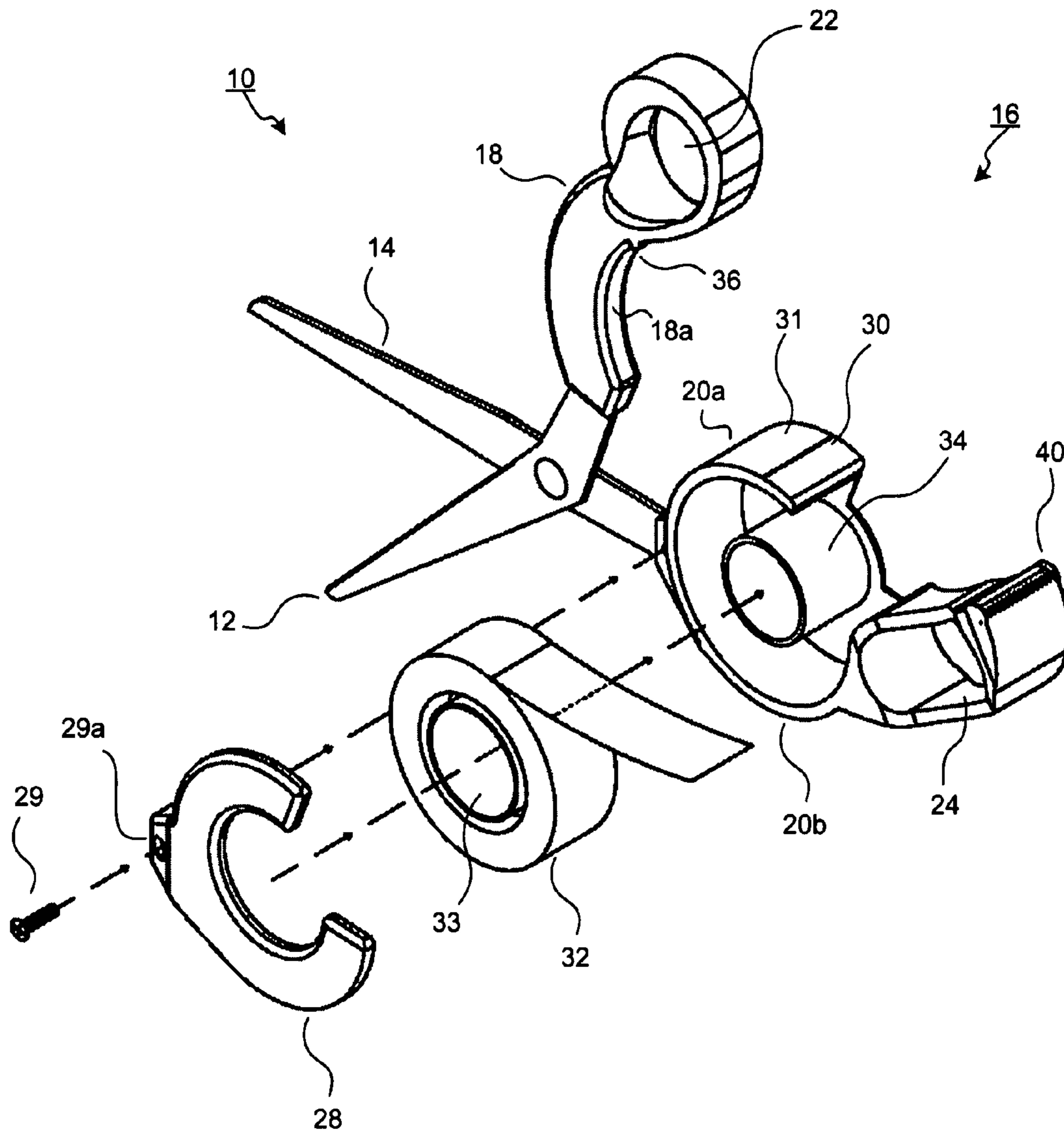

FIG. 3

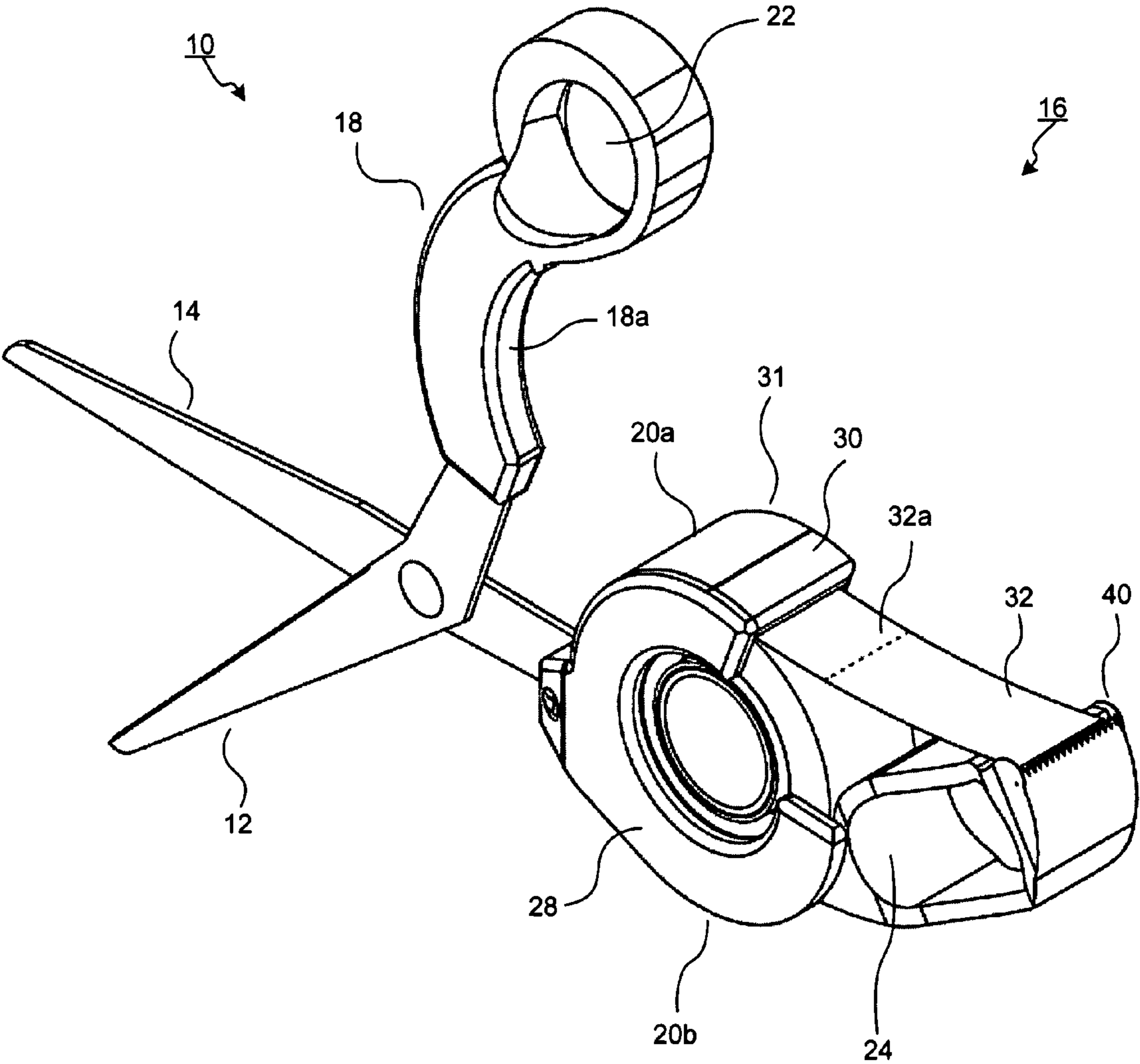

FIG. 4

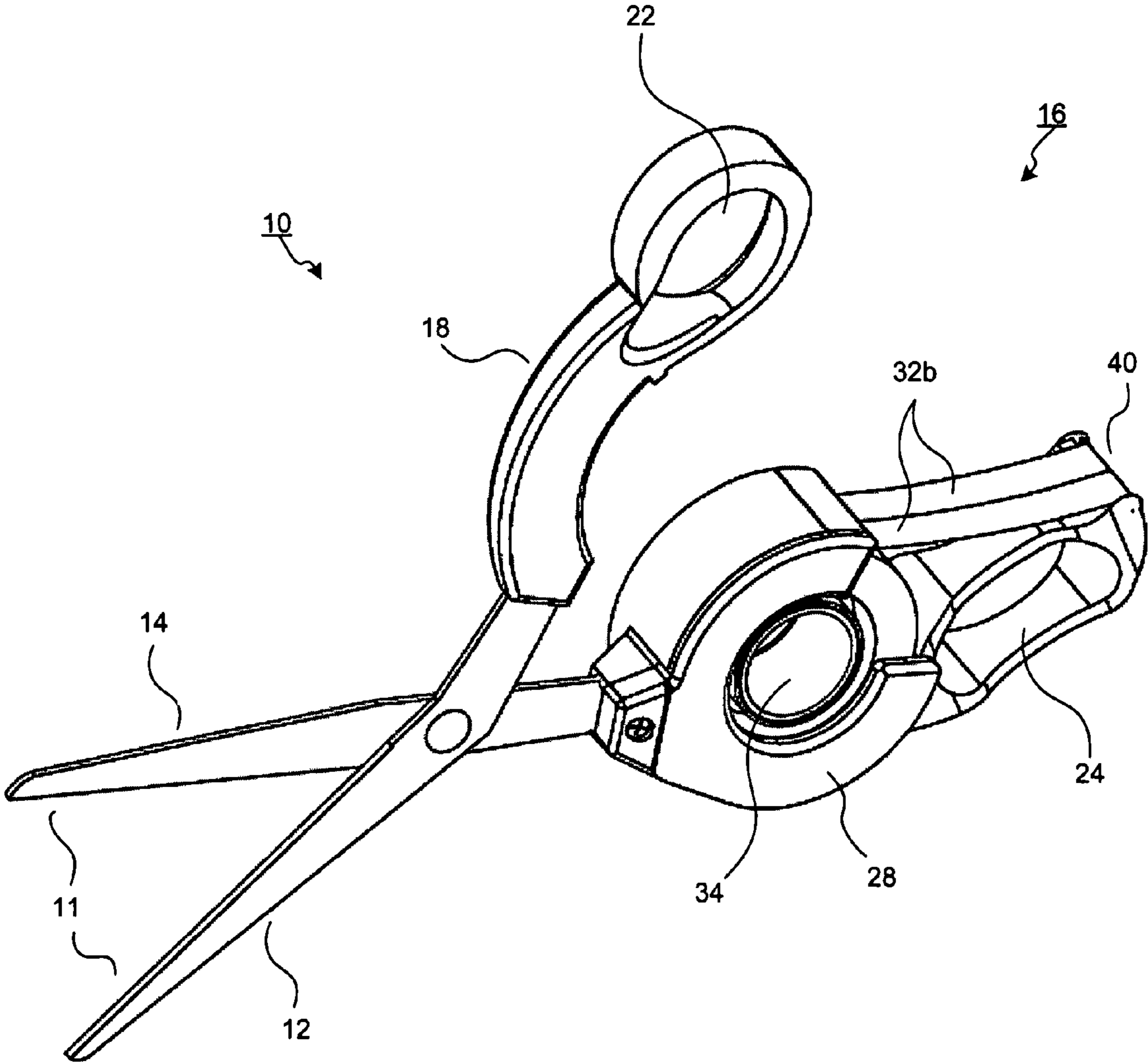

FIG. 5

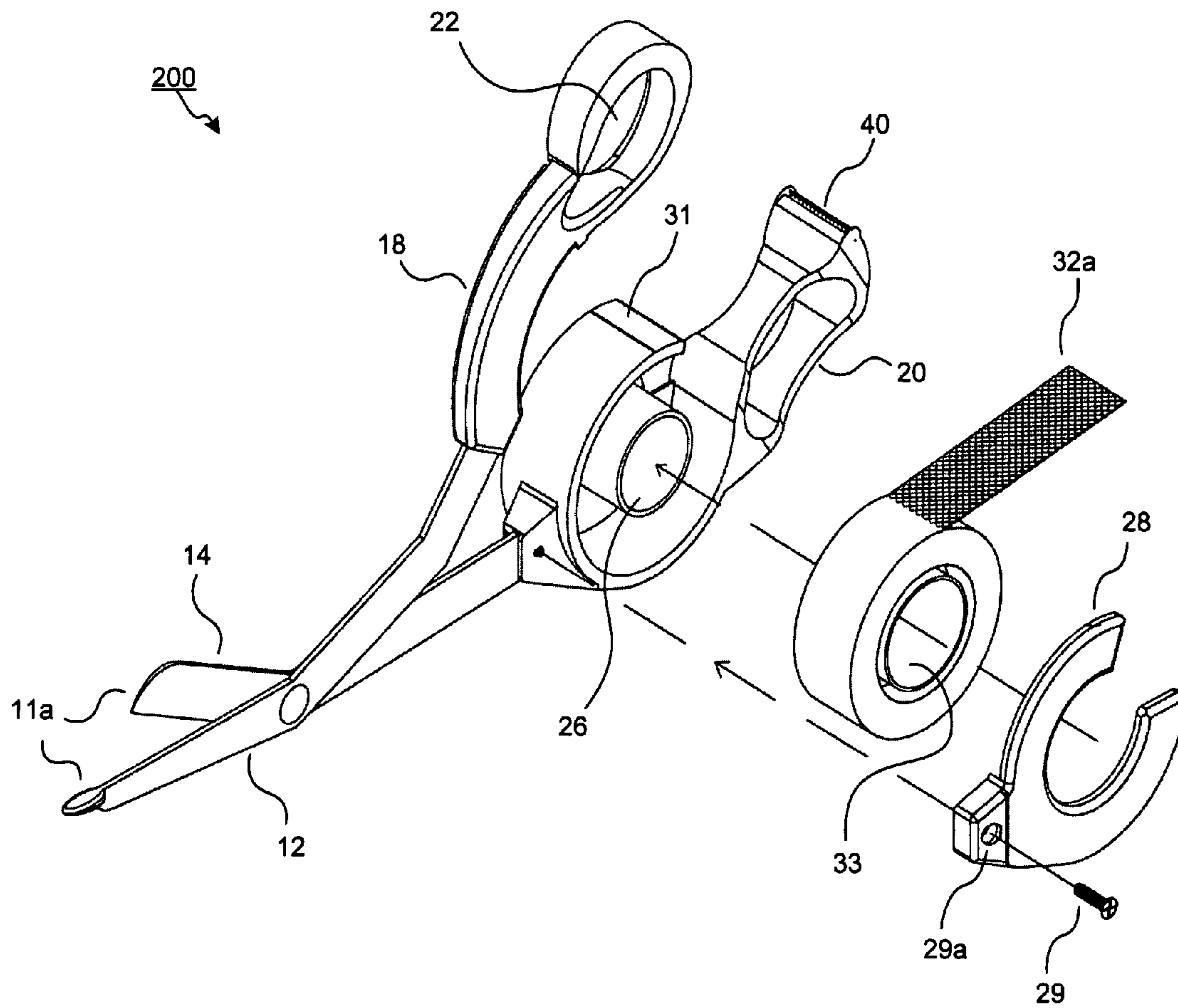

FIG. 6

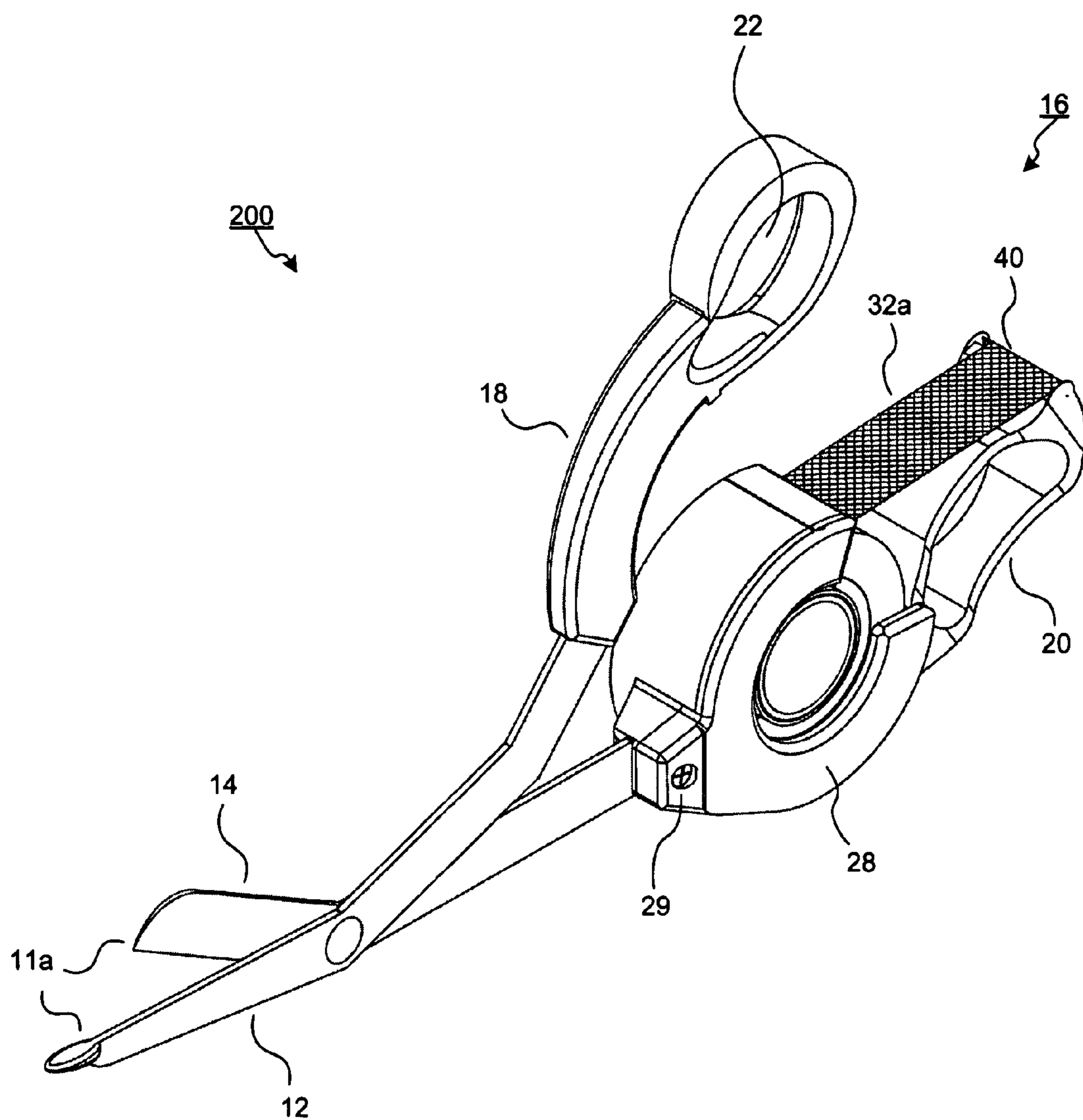

FIG. 7

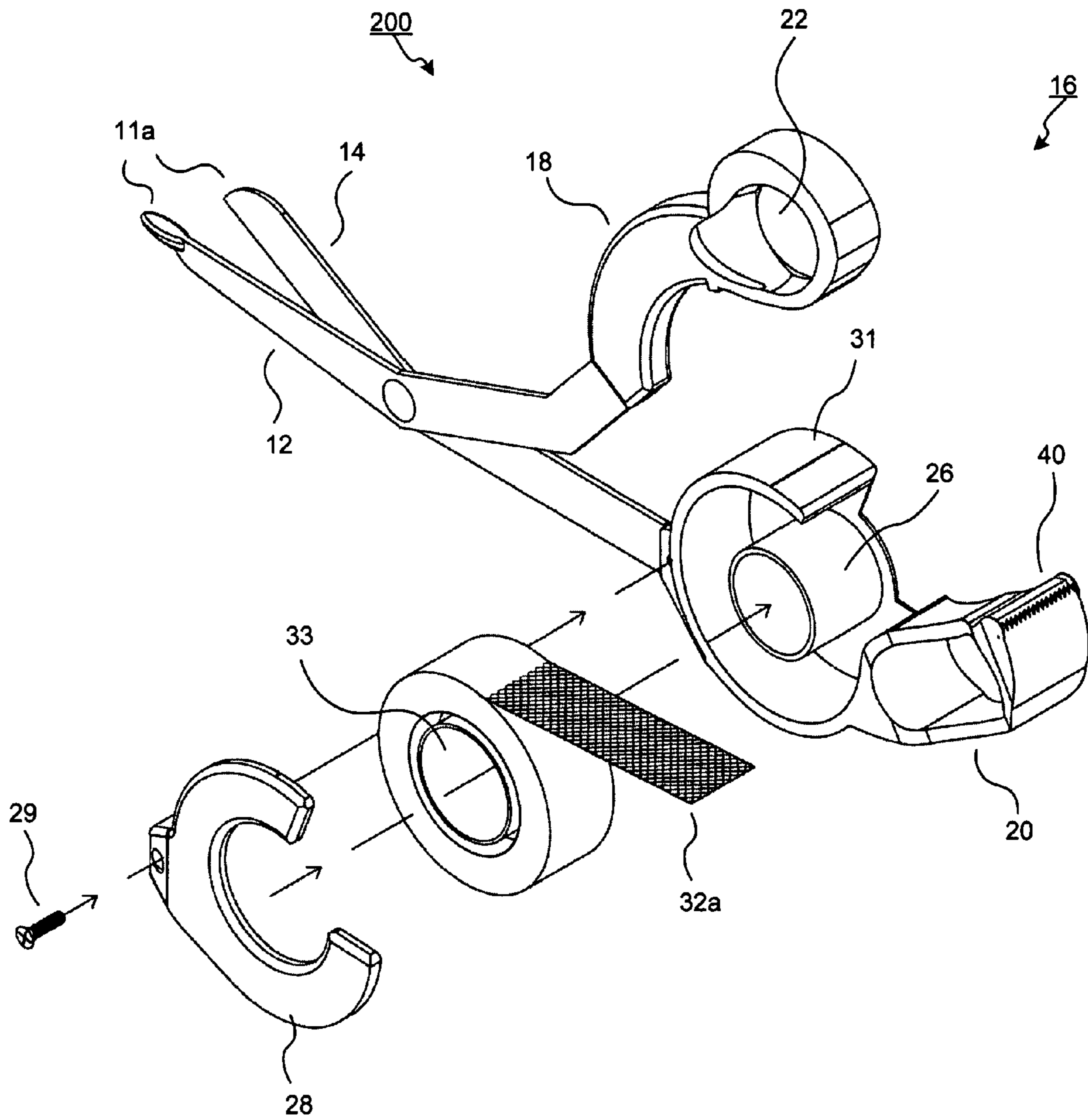

FIG. 8

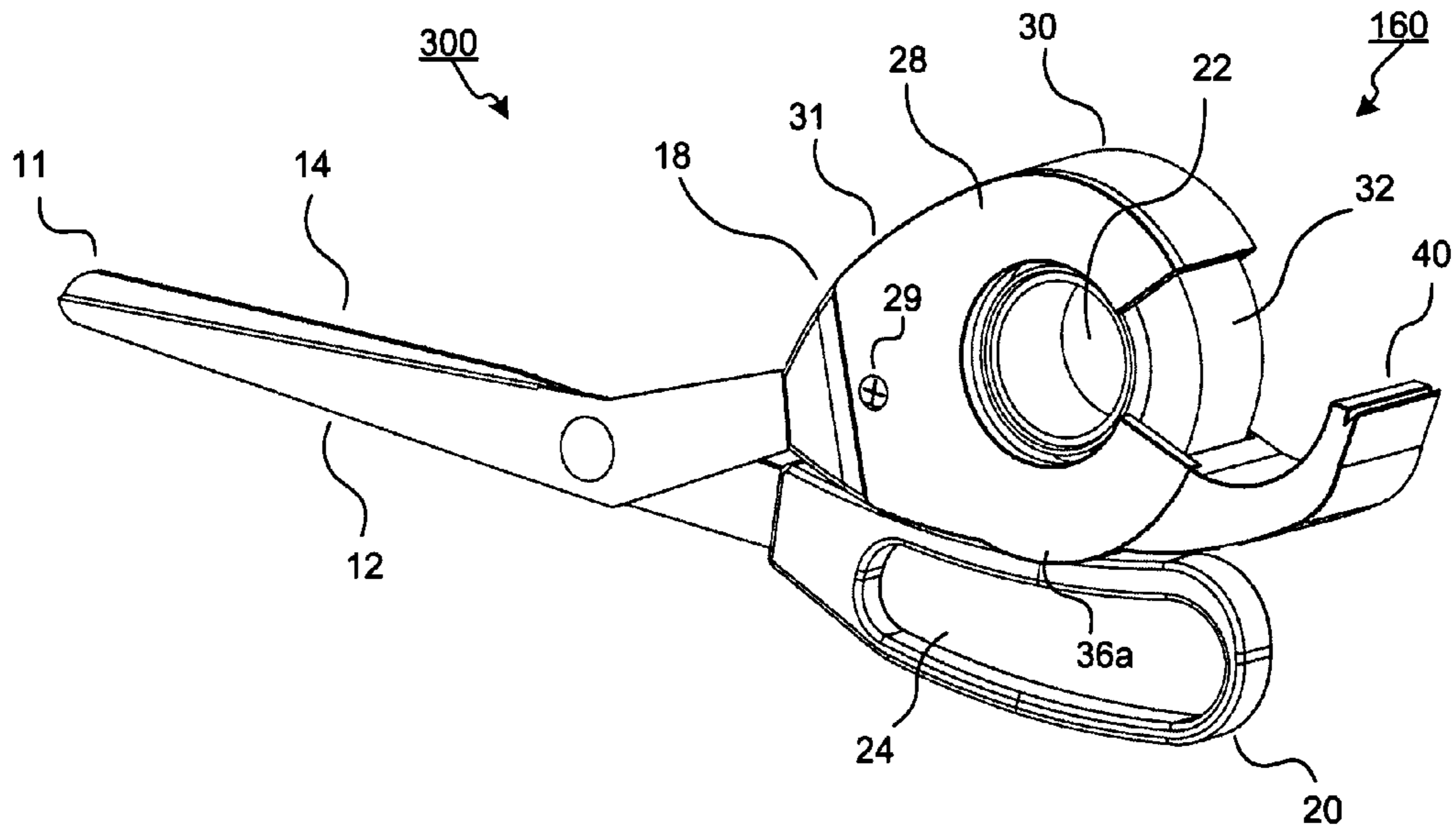

FIG. 9

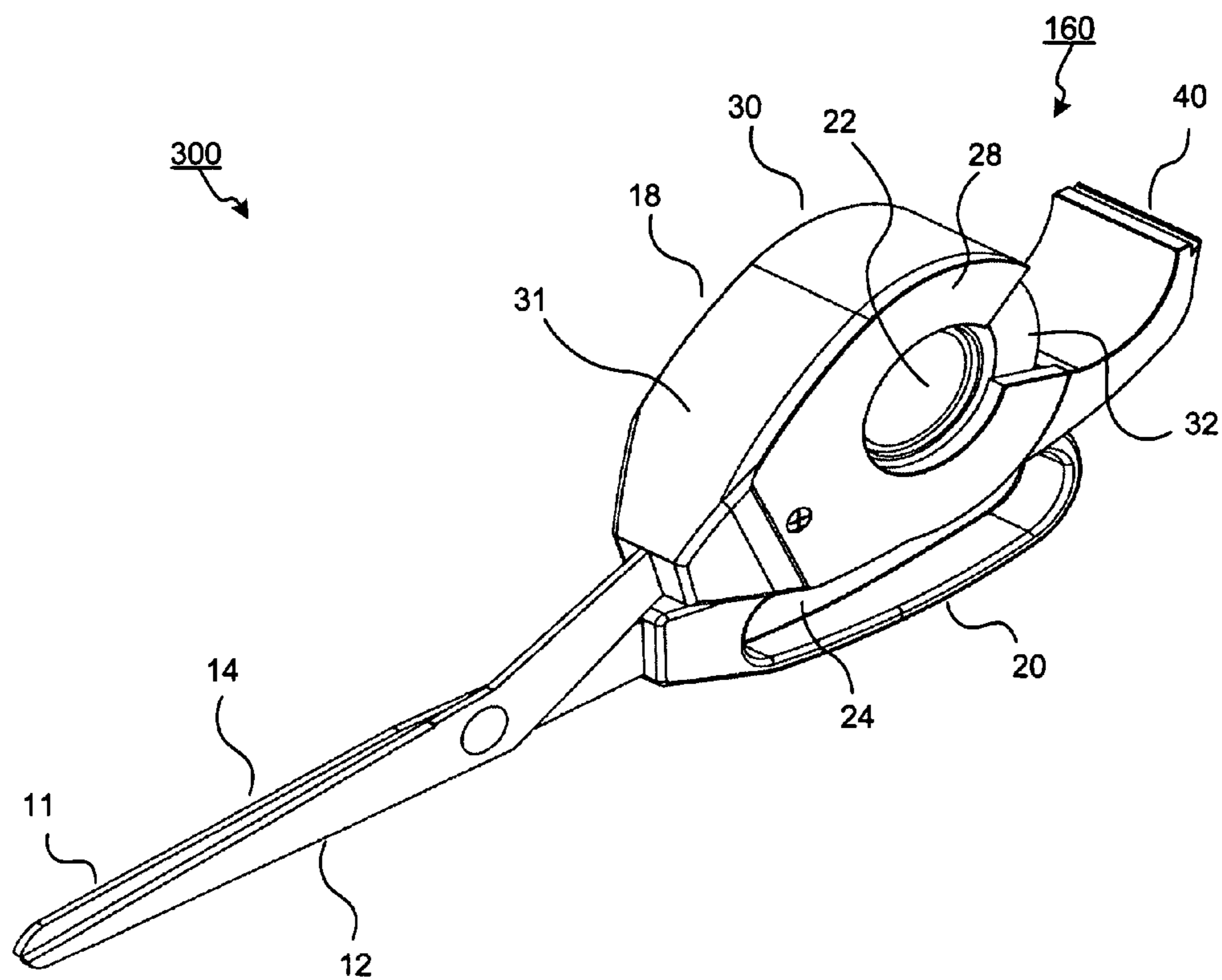

FIG. 10

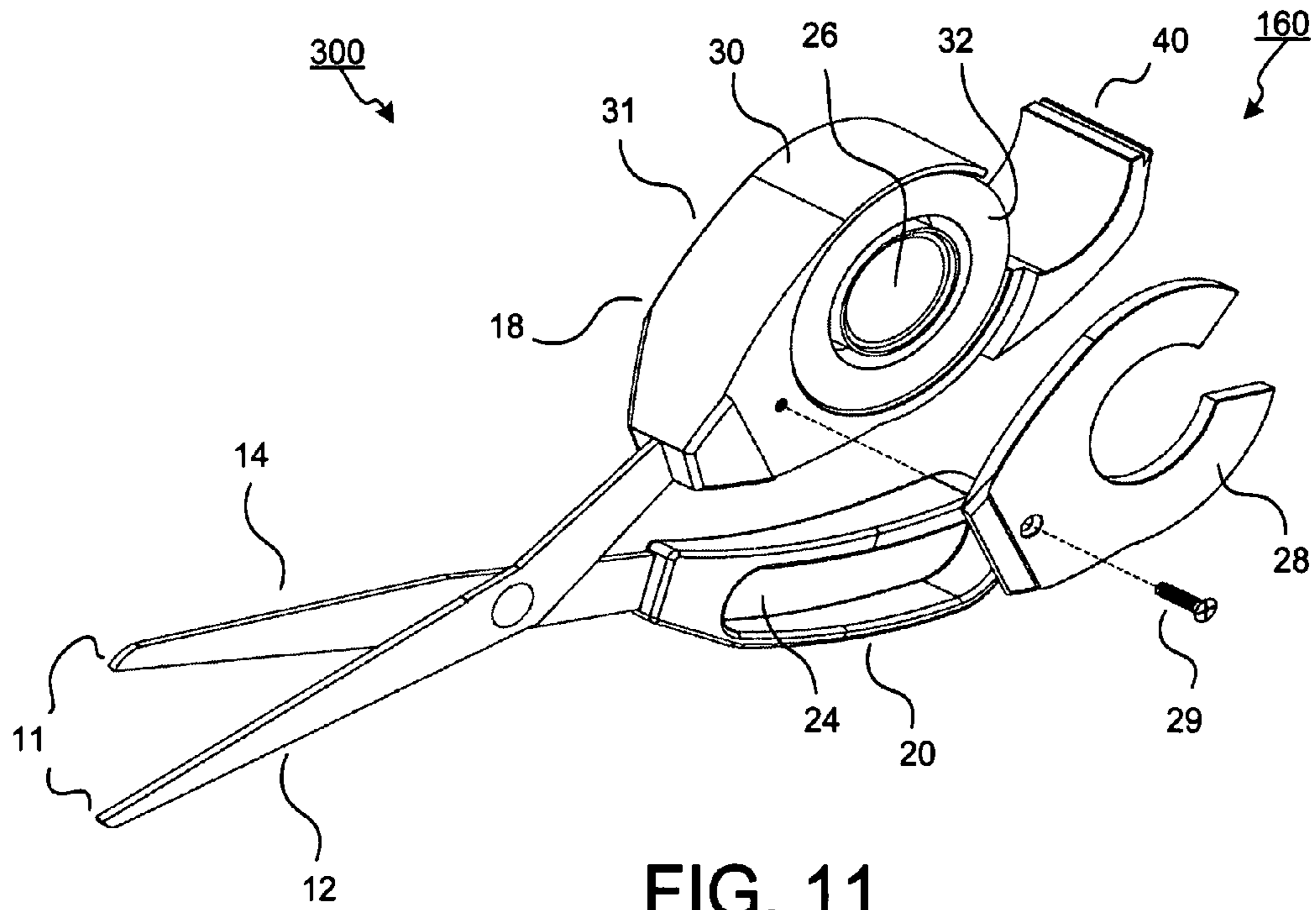

FIG. 11

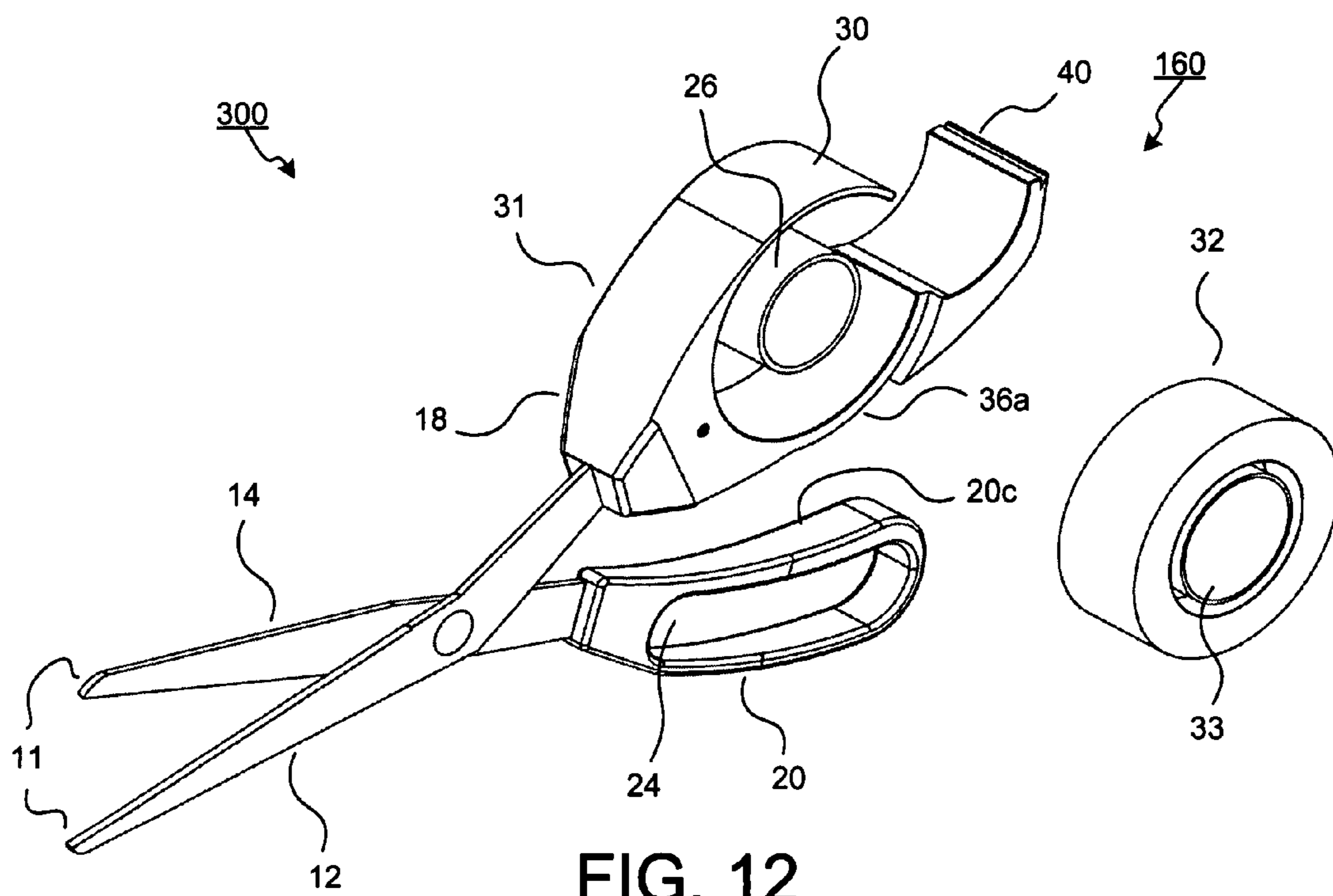

FIG. 12

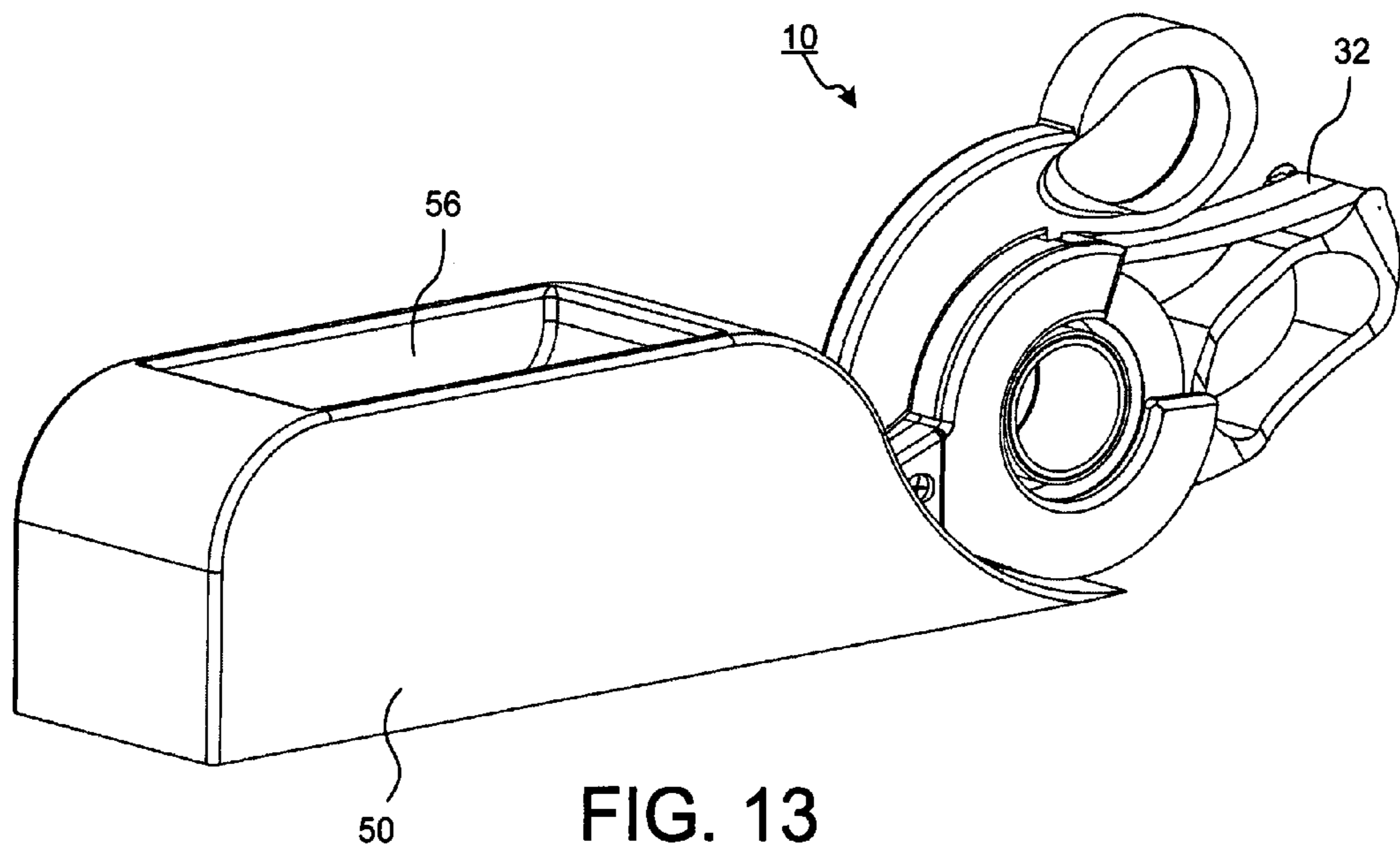

FIG. 13

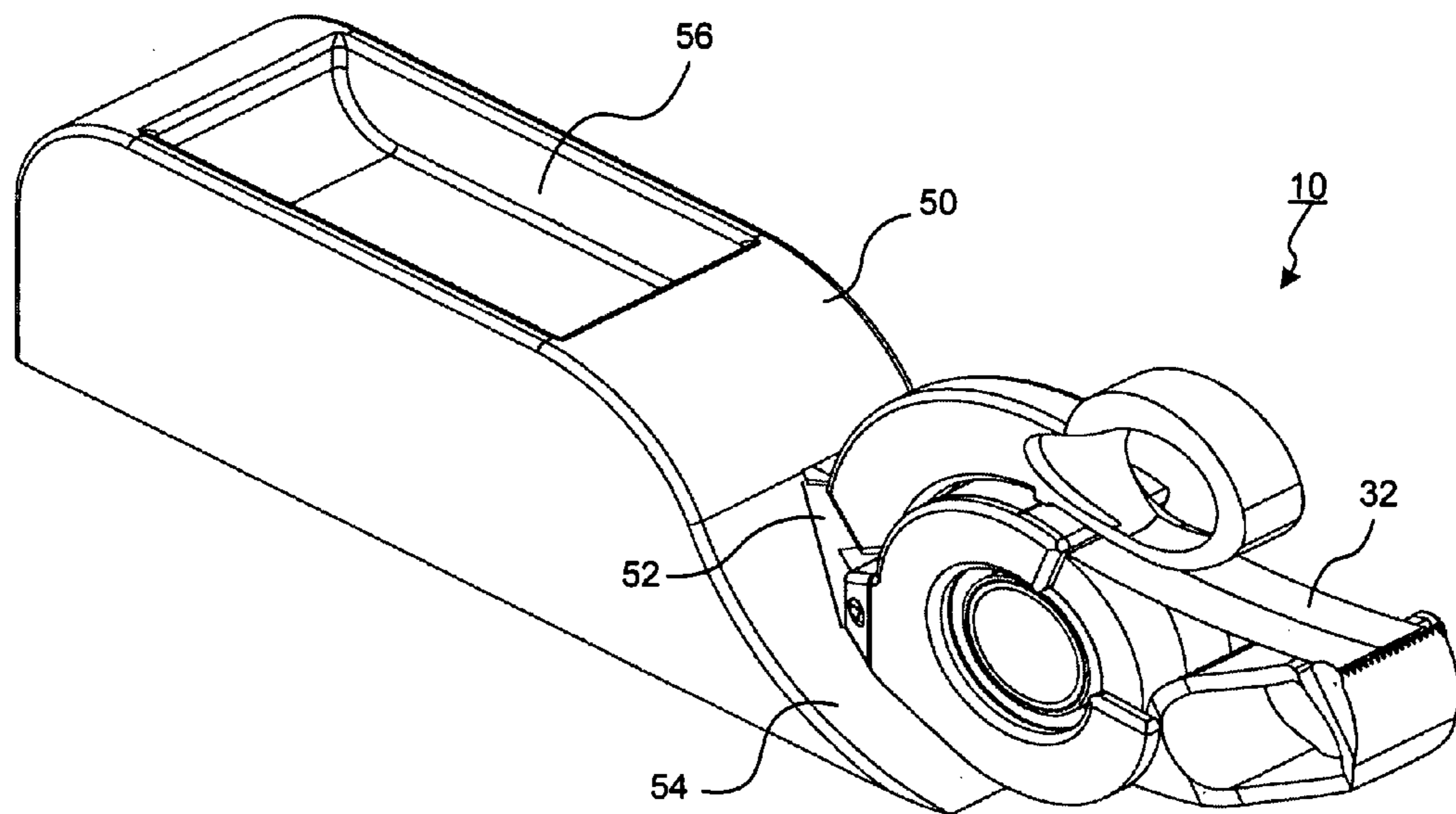

FIG. 14

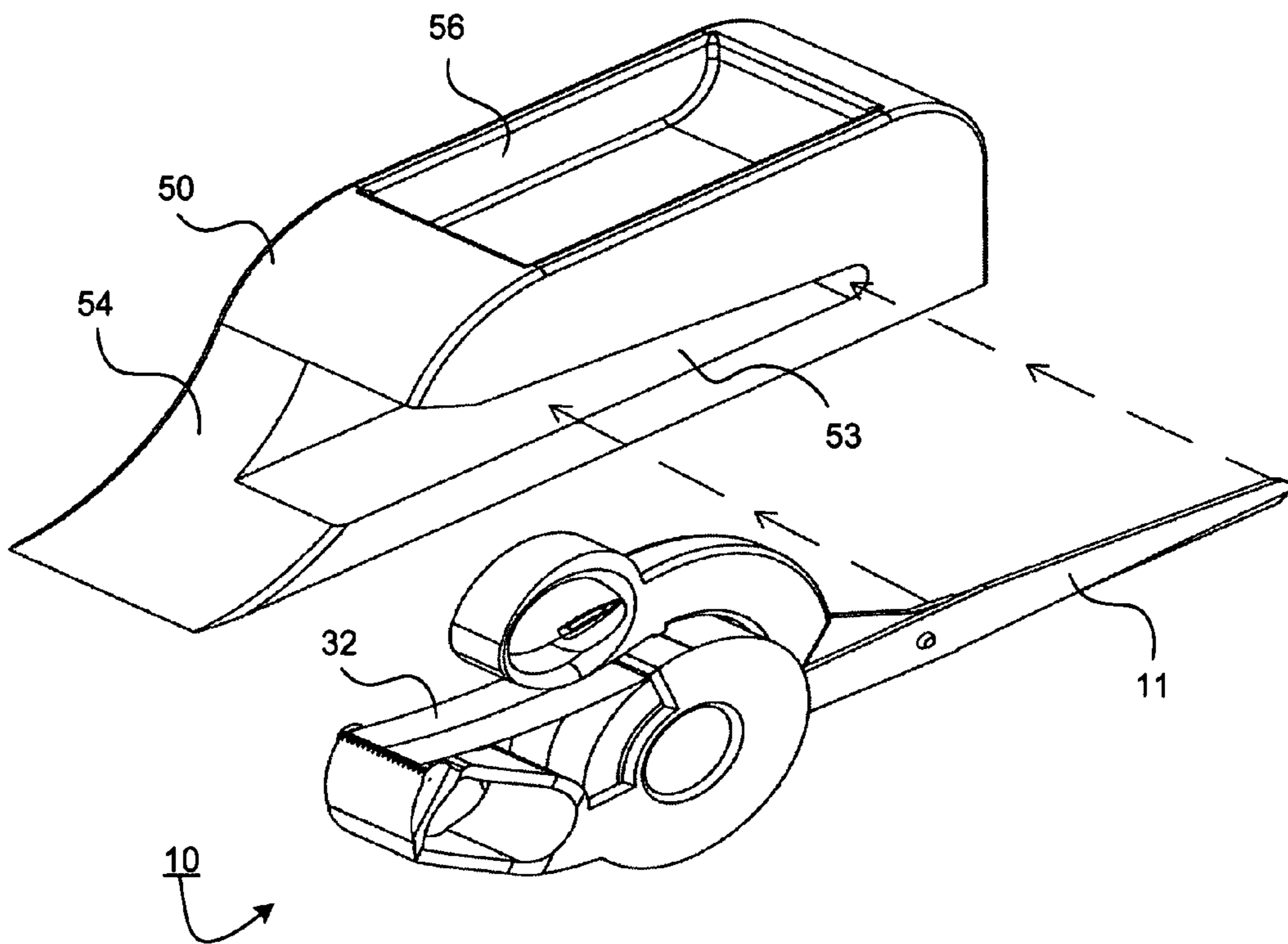

FIG. 15

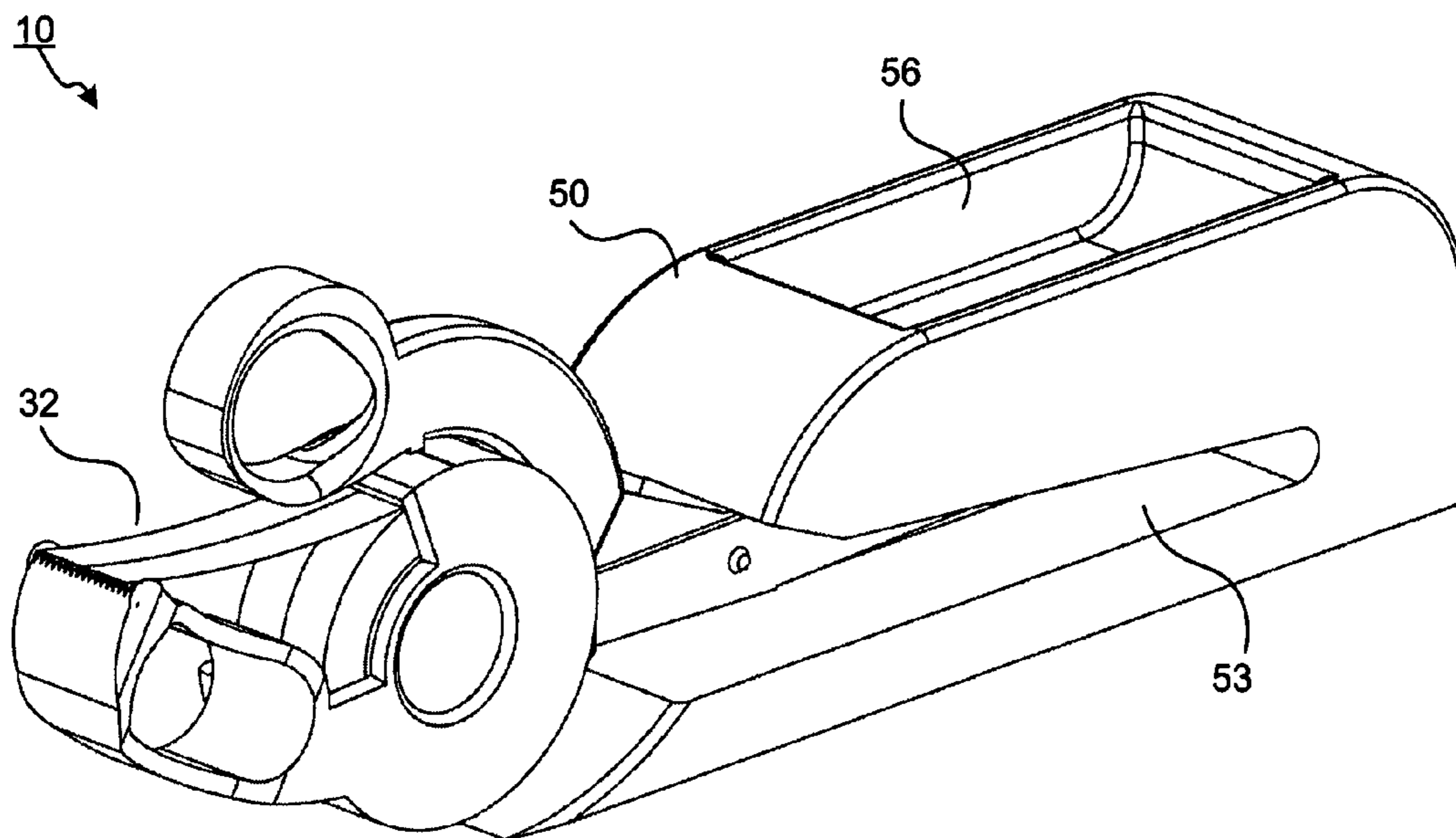

FIG. 16

SCISSORS WITH AN INTEGRATED TAPE DISPENSER

BACKGROUND OF THE INVENTION

1. Field of the Invention

The invention combines two common household items frequently used in conjunction with each other, as a single autonomous unit. Specifically, the invention combines scissors with a tape dispenser in a way that makes both easily usable as a single device.

2. Description of the Related Art

Almost all household scissors and tape dispensers are designed to perform one single respective function. Currently, scissors cut objects and tape dispensers dispense tape, each with its single unique purpose. Very often, when one uses a pair of scissors, one is in need of a tape dispenser, and vice versa. This is especially evident with the tasks of wrapping gifts, which requires the use of scissors and tape.

One apparent problem is that because each item, namely scissors and a tape dispenser, are separate items, and are frequently used in a variety of instances, when it is time to use the items collectively, they cannot be found in the same location. Quite the contrary occurs, that is, it seems that one can never find the scissors when the tape is found, and vice-versa, the tape cannot be found when the scissors are found.

Another problem that exists is that when using tape and scissors in conjunction with each other, the user cannot simultaneously manipulate both at the same time. The user must put down the pair of scissors each time he or she wants to use the tape dispenser, and vice-versa. This process of switching back and forth is inefficient; especially when wrapping multiple gifts, or any project that requires laborious cutting and taping.

Conventionally, scissors and tape dispensers are stored differently. For example, household scissors and tape are frequently stored out of sight. Scissors are commonly stored in a drawer of a desk, in a cupboard or the like, because they do not "stand alone" and contribute to disorganized clutter when they are placed otherwise. Traditional scissors lie on their side, slide around, and, consequently, are often tossed in a drawer when they are not being used. However, in an office environment, tape may be stored in a receptacle on a desk in plain view. This compounds the issue of scissors and tape not being located in the same place.

Another disadvantage is that most household tape dispensers are designed as disposable products. When one gets to the end of the tape roll, the dispenser is now a useless item and discarded, thereby creating waste.

SUMMARY OF THE INVENTION

An object of the present invention is to provide a unitary construction for an integrated apparatus including scissors and a dispenser.

This invention alleviates the problem of repeatedly switching between using a pair of scissors and a tape dispenser, and vice versa. According to this unitary construction, the tape dispenser may be used to dispense tape while holding the scissors and without having to put the scissors down. This use is compact, more efficient, saves time, and prevents the cumbersome task of having to constantly put down and pick up two different objects, i.e., the scissors and a tape dispenser.

According to an exemplary embodiment, the user may hold the scissors with one hand while the other free hand may be used to pull and cut a swath of tape from the integrated tape dispenser.

Another aspect of this invention is to construct the scissors and a dispenser in such a manner that the unitary construction apparatus can be placed on a plane surface with the scissor blades in an upright position ready for use. That is, at rest, the blades on the scissors are oriented in a ready to cut position that is perpendicular to the surface on which it is located. The bottom surface of the lower scissor handle preferably has a flat footprint incorporated into the lower scissor handle so the scissor tape dispenser may stand upright with the scissor blades perpendicular to the surface the flat foot of the lower scissor handle is resting upon. As such, the scissor tape dispenser may now sit on top of the user's desk, together, as one useful unitary tool.

According to yet another aspect of this invention, the roll on the tape is preferably reusable. When the user finishes a roll of tape, the user may easily remove the used roll out of the dispenser, and install a new roll.

Various types of materials may be dispensed by the scissor tape dispenser, including for example, an adhesive tape, ribbon, and the like. The dispensing material of this invention may be a single contiguous roll cut by a cutting implement integrated therewith or the dispensing material may be pre cut into predetermined usable lengths and consolidated onto the dispensing roll.

A further object of this invention is to adapt the scissor tape dispenser for various different types of cutting blades, including, but not limited to for example, cutting scissors for sports medicine professionals, and designed in such a way that different types of blades may be switched out depending on the cutting application.

Yet another aspect of this invention is to provide a cradle (or storage receptacle) including a storage slot into which the blades of the scissor tape dispenser are received. The cradle may include a tray or storage compartments for receiving various items, such as a plurality of paperclips, a spare roll of tape, a note pad, tacks, a pen, and/or any other suitable material.

These and other objects, features, and/or advantages may accrue from various aspects of embodiments of the present invention, as described in more detail below.

BRIEF DESCRIPTION OF THE DRAWINGS

Various exemplary embodiments of this invention will be described in detail, wherein like reference numerals refer to identical or similar components or steps, with reference to the following figures.

FIG. 1 illustrates an exploded isometric view of the combination scissor tape dispenser apparatus in accordance with this invention.

FIG. 2 depicts an isometric view of the combination scissor tape dispenser apparatus in accordance with this invention.

FIG. 3 illustrates another view of the exploded isometric combination scissor tape dispenser apparatus in accordance with this invention.

FIG. 4 shows another isometric view of the combination scissor tape dispenser apparatus in accordance with this invention.

FIG. 5 depicts an isometric view of the combination scissor tape dispenser apparatus including a dual material dispenser in accordance with this invention.

FIG. 6 illustrates an exploded isometric view of another combination scissor tape dispenser including an alternative blade in accordance with this invention.

FIG. 7 shows an isometric view of the combination scissor tape dispenser including the alternative blade in accordance with this invention.

3

FIG. 8 illustrates a different view of the exploded isometric view of the combination scissor tape dispenser including the alternative blade in accordance with this invention.

FIG. 9 illustrates an isometric view of a combination scissor tape dispenser including a tape dispenser in an alternative position in accordance with this invention.

FIG. 10 depicts another isometric angle of the combination scissor tape dispenser including the tape dispenser in the alternative position in accordance with this invention.

FIG. 11 illustrates an exploded isometric view of the combination scissor tape dispenser including the tape dispenser in an alternative position with the cover removed in accordance with this invention.

FIG. 12 illustrates an exploded isometric view of the combination scissor tape dispenser including the tape dispenser in an alternative position with the tape removed in accordance with this invention.

FIG. 13 illustrates an isometric view of the combination scissor tape dispenser disposed within a cradle in accordance with this invention.

FIG. 14 illustrates another isometric view from a different angle of the combination scissor tape dispenser disposed within the cradle in accordance with this invention.

FIG. 15 illustrates an exploded isometric view of the combination scissor tape dispenser removed from the cradle in accordance with this invention.

FIG. 16 illustrates an isometric view of the combination scissor tape dispenser disposed within the cradle in accordance with this invention.

DETAILED DESCRIPTION OF EXEMPLARY EMBODIMENTS

Particular embodiments of the present invention will now be described in greater detail with reference to the figures.

The present invention remedies the problems associated with current scissor and tape dispenser devices in several ways. First, the scissors and tape dispenser are integrated into one unit. Therefore, when one locates the scissors, the tape dispenser is also located, and vice versa. The functionality of neither the scissors nor tape dispenser is compromised by the integration of the scissor and tape dispenser as a single integral unit.

This invention also eliminates the problem of putting the scissors down in order to pick up a tape dispenser, and vice versa. Simultaneously, the tape dispenser can be used to dispense tape while holding the scissors and without having to put the scissors down. This is accomplished because while one hand holds the scissors, the other is free hand can pull and cut tape from a tape dispenser incorporated into the scissors.

In operation, the actual taping action can be performed by using the thumb used to grasp the scissors and the "free" hand; thereby allowing one hand to cut and the other hand to tape without monotonously picking up and putting the scissors down. This invention allows the user to be more efficient, save time, and prevent the user from having to constantly switch between picking up and putting down a pair of scissors and a tape dispenser.

According to an exemplary embodiment, the scissor tape dispenser may now be used as a "stand alone" object. The construction of the scissor tape dispenser of this invention can be stored in plain sight and ready for use; similar to an office type stand-alone tape dispenser because the bottom of the lower scissor handle preferably has a flat foot incorporated into the scissor tape dispenser to allow the scissor tape dispenser to stand upright with the scissor blades parallel to the

4

surface it is resting upon. The scissors and tape may now sit on top of the user's desk, together, as one useful tool.

In addition, the tape roll preferably is reusable. When the user finishes a roll of tape, the user simply pulls the used roll out of the dispenser, and installs a new roll. This eliminates the throw-away disposable tape dispenser, and saves the consumer money because now the user only needs to buy new rolls. Thus, less waste is produced and, at the same time, money is saved. With reference to the drawings and in more detail, the scissor tape dispenser will now be described.

FIG. 1 illustrates an exploded isometric view of a combination scissor tape dispenser 10 in accordance with an exemplary embodiment. The scissor tape dispenser 10 includes a pair of blades 11 defined as a first elongated cutting member 12 and a second elongated cutting member 14. As illustrated in FIGS. 1-4, the scissor blades 11 may be standard scissor blades. Preferably, the angle of blades 11 is unchanged from the blade 11 to handle.

The scissor handle 16 of the invention has been re-configured to accommodate a tape dispenser portion 30 as will be described in more detail below. In particular, the scissor handle 16 includes two handle portions 18 and 20. The first handle portion 18 is rigidly connected to the first elongated cutting member 12. The second handle portion 20 is rigidly connected to the second elongated cutting member 14. The first handle portion 18 includes a first looped portion 22. Similarly, the second handle portion 20 includes a second looped portion 24.

The scissor handle 16 may be made from a variety of different materials, including but not limited to, a polymer, a metal, a rubber, and/or any other type of material suitable to be used as a scissor handle. Another aspect of this invention is to modularly construct the scissors so that cutting blades of the scissor tape dispenser can be interchangeable and swapped out for various other types of implements, such as gauze cutting shears, electrical wire cutting and stripping shears, metal cutting shears, and the like.

FIGS. 1-4 depict in various angles, an integrated tape dispenser 30. The tape dispenser 30 includes a tape dispenser housing 31 integrated into the second handle portion 20 of the scissor tape dispenser 10. The first handle portion 18 is shown ergonomically modified in construction to rest on top of the tape dispenser housing 31 on the second handle portion 20 when the blades 11 are closed. The through-hole of the first looped portion 22 in the first handle portion 18 is also shown ergonomically configured to suit the hand of a user. That is, for comfort, the first looped portion 22 (or thumb hole position) is substantially similarly located in position to a traditional pair of scissors.

As shown in FIGS. 3-4, a bottom surface 18a of the first handle portion 18 is contoured to extend over the outer mating top portion 20a surface of the tape dispensing housing 31. A stop tab 36 is suitably disposed on the bottom surface 18a to abut adjacent to a top portion 20a of the tape dispenser housing 31. The stop tab 36 may be designed slightly advanced forward toward the scissor blades 11. The stop tab 36 may take a variety of different configurations depending on the construction of the scissor tape dispenser 10.

By way of example, FIG. 12, shows the stop tab 36a being configured as a curved portion in the tape dispenser housing 31. According to this figure, an outermost curved portion is defined by the stop lobed-tab 36a that rests against the second handle portion 20 when the scissor tape dispenser 300 is in a closed position as shown in FIGS. 9-10.

According to this invention, the tape dispenser 30 may be integrated on the handle 16 at various locations. As depicted in FIGS. 1-4, the tape dispenser housing 31 is disposed on the

5

second handle portion **20** between the second looped portion **24** and second elongated cutting member **14**. A through-hole **26** is disposed central to the tape dispenser housing **31** and may be configured to receive at least one of the user's fingers, such as an index finger. In operation, the user may simulta-

neously grip the second looped portion **24** and the through-hole **26** with one hand to maintain better control of the scissor tape dispenser **10**.
 In more detail, the tape dispenser **30** includes a wide flat tape dispenser housing **31** having a central reel **34** defining a central through-hole **26**, a cutting implement **40**, a tape **32** wrapped around a roll **33** and a removable cover **28**. As shown in FIGS. **1** and **3**, the cover **28** may be removed to replace the tape **32** recessed within the tape dispenser housing **31** when the tape **32** requires replacement. In assembly, the roll **33** of the tape **32** is centrally disposed around the reel **34** and the cover **28** is secured to the tape dispenser housing **31** with a fastener **29**. As shown in FIGS. **2-3**, in operation the tape **32** is fed through an opening in the tape dispenser housing **31** toward the cutting implement **40** where a swath can be cut from the tape **32**.

The removable cover **28** of the tape dispenser **30** is constructed to enable the reel of tape **32** (and/or other dispensing materials) to be quickly and easily replaced within the tape dispenser housing **31**. The removable cover **28** may include a plurality of aligning ridges, seams and/or the like (not shown) which align and secure the removable cover **28** in an operable position over the reel of tape **32** and around the reel **34**. In position, a fastener **29** is disposed through an alignment hole **29a** and secured to the flat tape dispenser housing **31**. Although shown as a threaded fastener, the fastener **29** may be any type of suitable fastening mechanism, such as a clip, a latch, a button and the like.

The material being dispensed from the reel of tape **32** may be selected from a variety of adhesives and/or materials. For example, the tape **32** used with the scissor tape dispenser **10** may range in material from an adhesive tape, to a non-adhesive tape, such as gauze, ribbon, a polymer, rubber, twine, a measuring tape, string and/or any other type of material capable of being wound around the reel **34**.

According to another aspect of this invention, the material dispensed from the reel of tape **32** may be wrapped onto the roll **33** in a variety of different ways. For example, as shown in FIGS. **2** and **4**, the tape **32** may be pre cut into predetermined usable swath lengths **32a** (as shown in perforated hidden lines) and consolidated onto the roll **33** at the time of manufacture. According to this exemplary embodiment, the pre cut material being dispensed does not have to be cut into lengths by the cutting implement **40**.

FIG. **5** illustrates another aspect of this invention in which multiple tape rolls **32b** of a material may be dispensed from the tape dispenser housing **31**. That is, the tape dispenser by the scissor tape dispenser **10** may accept multiple rolls of material about the reel **34**. As shown, the scissor tape dispenser **10** includes a multiple tape rolls **32b** wrapped around the tape dispensing reel **34**. Each of the individual tape portions of the multiple tape rolls **32b** may be dispensed simultaneously or individually as desired.

Referring back to FIGS. **1-4**, the lower portion of the second handle portion **20** that rests on for example, a desk surface, may be constructed with a wide flat lower scissor handle base **20b**. The advantage of this construction is that the scissor tape dispenser **10** may sit at rest on a surface in an upward position in which the flat sides of the blades **11** stand vertically upright perpendicular to the surface on which the scissor tape dispenser **10** is placed. The benefit of this construction is that the scissor tape dispenser **10** is positioned upright and in

6

a ready to cut position. The bottom of the lower scissor handle preferably has a flat footprint incorporated into the scissor tape dispenser **10**. As such, the scissor tape dispenser **10** may sit ready for use on top of the user's desk, as a single useful unitary tool.

As shown in FIGS. **1-5**, the cutting implement **40** is provided at the peripheral end of the handle portion (second handle portion **20**) including the tape dispenser housing **31** to cut a swath of tape from the reel of tape **32** (or tapes **32a**). The cutting implement **40** includes a plurality of sharp serrated edges used for cutting a swath of tape **32** from the tape dispenser **30**. It is to be understood that various types of cutting implements may be employed in accordance with this invention which are now known or later discovered.

Furthermore, it is an object of this invention to provide a safety guard (not shown) to cover the cutting implement **40**. For example, the cutting implement **40** may be designed similar to a conventional packing tape dispenser gun which may include an "automatic tape cutter." In use, the cutting implement is concealed until a pressure is applied to cutting implement **40** which in response a cutting implement automatically cuts the tape **32**.

The scissor tape dispenser **10** is adapted to work in conjunction with a variety of different types of scissor style implements, such as for example, cutting shears used in the medical field, cutting shears by sports medicine professionals, electrical wire strippers in which an electrical tape may be integrated, metal cutting shears, and the like. In more detail, the blades of the electrical wire cutting and stripping shears may include a section for stripping various gauge wires and a section for cutting the wire as conventionally implemented in typical electrical wire cutting and stripping shears. Likewise, the blades of the electrical wire cutting and stripping shears may be interchanged into the scissor tape dispenser of this invention. In the alternative, the handle and the electrical wire cutting and stripping blades may be constructed as a unitary structure including a dispenser for electrical tape, or the like.

FIGS. **6-8** illustrate isometric views of a medical scissor tape dispenser **200** depicting an alternative set of blades (including a blunt nose on the first elongated cutting member **12**) used for example in medical and sports medicine applications. FIG. **6** illustrates the versatility of this invention being applicable to a variety of cutting implements. It is to be understood that the medical scissor tape dispenser **200** shown in FIGS. **6-8** include the features and functionality of the scissor tape dispenser **10** discussed above with respect to FIGS. **1-5**. The medical scissor tape dispenser **200** illustrates a modified set of blades **11a**. Likewise, an alternative material tape **32a** (such as an athletic tape, gauze, or the like) is wrapped around the roll **33** that is to be dispensed in accordance to this embodiment.

In FIGS. **1-8**, the reel of tape **32**, **32a** is shown housed in a tape dispenser housing **31** located on the lower handle portion **20** between the second elongated cutting member **14** and the second looped portion **24**. However, it is also to be understood that the placement of the tape dispenser **30** integrated onto the scissor tape dispenser is versatile and may be located at any position. For example, the tape dispenser **30** may be integrated into the handle, or onto the blades **11**, **11a** of the scissor tape dispenser.

FIGS. **9-12** illustrate the tape dispenser housing **31** of the tape dispenser **30** being constructed as part of the upper handle portion **18** of the modified handle **160**. According to this exemplary embodiment, the tape dispenser housing **31** is constructed around the first **22** looped portion on the upper handle portion **18**. It is further understood that the scissor tape dispenser **300** shown in FIGS. **9-12** includes the features and

functionality of the scissor tape dispensers **10**, **200** discussed above with respect to FIGS. **1-8**. FIGS. **11** and **12** illustrate the removal of the cover **28** and reel of tape **32** of the scissor tape dispenser **300**.

FIGS. **13-16** depict a cradle **50** (or storage receptacle) capable of being used in accordance with this invention. As shown in FIGS. **13-16**, the blades **11** of the scissor tape dispenser **10** are received in a front-entry slot **52**. The front-entry slot **52** is configured to receive the blade of the scissor tape dispenser **10**.

FIGS. **15** and **16** depict the blades **11** of the scissor tape dispenser **10** being slid into the side-open slot **53** from an open side of the cradle **50**. However, the side-open slot **53** may be constructed as a front-entry slot **52** as shown in FIGS. **13-14** into which the cradle **50** directly receives the blades **11** inserted into the front-entry slot **52** in the forward side **54** of the cradle **50**. As shown in the storage position in FIGS. **13-14** and **16**, the cradle **50** may be designed to allow the tape **32** to be dispensed while the scissor tape dispenser **10** remains firmly secured to the cradle **50**.

The cradle **50** may be constructed in variety of different ways and may be adapted for a plurality of uses. FIGS. **13-16** illustrate the cradle **50** including a tray **56** for receiving various items, such as a plurality of paperclips, and the like. Other uses the cradle can provide may include, for example, holding a spare tape **32**, holding a pen and note pad, and/or any other suitable material and/or function aligned with using scissors, a tape dispenser and/or other office equipment.

It will be recognized by those skilled in the art that changes or modifications may be made to the above described embodiment without departing from the broad inventive concepts of the invention. It is understood therefore that the invention is not limited to the particular embodiment which is described, but is intended to cover all modifications and changes within the scope and spirit of the invention.

What is claimed is:

1. A scissors comprising:
 - a first member including a first elongated cutting member integrated with a first looped handle portion;
 - a second member pivotally connected to the first member, the second member including a second elongated cutting member integrated with a tape dispenser;
 - wherein the tape dispenser further comprises a second looped handle portion adapted to receive at least one finger, a dispenser reel, a cutting implement integrated as part of the second looped handle portion, and tape;
 - and wherein the tape is received by the reel and when dispensed, the tape travels from the reel across the second looped handle portion where the tape is forced against the cutting implement to cut the tape.
2. The scissors recited in claim 1, wherein the reel has a through-hole portion adapted to receive at least one finger.
3. The scissors recited in claim 1, wherein the tape dispenser is selected from at least one of: an adhesive tape dispenser; an athletic tape dispenser; a surgical tape dispenser; an electrical tape and a ribbon dispenser.

4. The scissors recited in claim 1, wherein the dispenser has a wide base allowing sides of the first and second elongated cutting member to rest upright.

5. The scissors recited in claim 1, wherein the dispenser includes a removable cover for replacing the tape being dispensed.

6. The scissors recited in claim 1, wherein the tape is a multiple tape roll that dispenses more than one material.

7. The tool assembly comprising:

- a pair of scissors further comprising:
 - a first member including a first elongated cutting member integrated with a first looped handle portion;
 - a second member pivotally connected to the first member, the second member including a second elongated cutting member integrated with a tape dispenser;
- wherein the tape dispenser further comprises a second looped handle portion adapted to receive at least one finger, a dispenser reel, a cutting implement integrated as part of the second looped handle portion, and tape;
- and wherein the tape is received by the reel and when dispensed, the tape travels from the reel across the second looped handle portion where the tape is forced against the cutting implement to cut the tape.

8. The tool assembly recited in claim 7, wherein the reel has a central curved loop through-hole portion adapted to receive the at least one finger.

9. The tool assembly recited in claim 7, wherein the dispenser has a wide base allowing sides of the first and second elongated cutting member to rest upright.

10. The tool assembly recited in claim 7, wherein the dispenser includes a removable cover for replacing the tape being dispensed.

11. The tool assembly recited in claim 7, wherein the tape is a multiple tape roll that dispenses more than one material.

12. The tool assembly recited in claim 7, further includes a cradle into which the first and second elongated cutting members are stored with a flat side of the first and second elongated cutting members positioned upright.

13. A scissors comprising:

- a first member including a first elongated cutting member integrated with a first looped handle portion;
- a second member pivotally connected to the first member, the second member including a second elongated cutting member integrated with a tape dispenser;
- wherein the tape dispenser further comprises tape, a dispenser reel, a cutting implement, and a second looped handle portion extending between the reel and the cutting implement wherein the second looped handle portion is adapted to receive at least one finger;
- and wherein the tape is received by the reel and when dispensed, the tape travels from the reel across the second looped handle portion where the tape is forced against the cutting implement to cut the tape.

14. The scissors recited in claim 13, wherein the dispenser has a wide base allowing sides of the first and second elongated cutting member to rest upright.

* * * * *