

US007774693B2

(12) **United States Patent**
Bodin et al.

(10) **Patent No.:** **US 7,774,693 B2**
(45) **Date of Patent:** ***Aug. 10, 2010**

(54) **DIFFERENTIAL DYNAMIC CONTENT DELIVERY WITH DEVICE CONTROLLING ACTION**

FOREIGN PATENT DOCUMENTS

WO WO 01/20481 A2 3/2001

(75) Inventors: **William K. Bodin**, Austin, TX (US);
Michael J. Burkhart, Round Rock, TX (US);
Daniel G. Eisenhauer, Austin, TX (US);
Daniel M. Schumacher, Pflugerville, TX (US);
Thomas J. Watson, Pflugerville, TX (US)

(Continued)

OTHER PUBLICATIONS

Capra et al., "WebContext: Remote Access to Shared Context", ACM International Conference Proceeding Series, vol. 15, Proceedings of the 2001 Workshop on Perceptive User Interfaces, 2001, p. 1-9.*

(Continued)

(73) Assignee: **International Business Machines Corporation**, Armonk, NY (US)

(*) Notice: Subject to any disclaimer, the term of this patent is extended or adjusted under 35 U.S.C. 154(b) by 201 days.

Primary Examiner—Amelia Rutledge

(74) *Attorney, Agent, or Firm*—Edward J. Lenart; Justin Dillon; Biggers & Ohanian L

This patent is subject to a terminal disclaimer.

(57) **ABSTRACT**

(21) Appl. No.: **12/171,758**

(22) Filed: **Jul. 11, 2008**

(65) **Prior Publication Data**

US 2008/0263435 A1 Oct. 23, 2008

Related U.S. Application Data

(63) Continuation of application No. 10/756,145, filed on Jan. 13, 2004, now Pat. No. 7,430,707.

(51) **Int. Cl.**
G06F 17/00 (2006.01)

(52) **U.S. Cl.** **715/200**

(58) **Field of Classification Search** **715/200**
See application file for complete search history.

(56) **References Cited**

U.S. PATENT DOCUMENTS

3,644,674 A 2/1972 Mitchell et al.

(Continued)

Differential dynamic content delivery including providing a session document for a presentation, wherein the session document includes a session grammar and a session structured document; selecting from the session structured document a classified structural element in dependence upon user classifications of a user participant in the presentation; presenting the selected structural element to the user; identifying a device controlling action; and executing the device controlling action to control a device for the user. In many embodiments, identifying a device controlling action includes identifying a device controlling action in dependence upon a presentation control instruction. In some embodiments, identifying a device controlling action further includes identifying a device controlling action in dependence upon a spoken key word. In some embodiments, identifying a device controlling action further includes identifying a device controlling action in dependence upon a classified structural element.

12 Claims, 19 Drawing Sheets

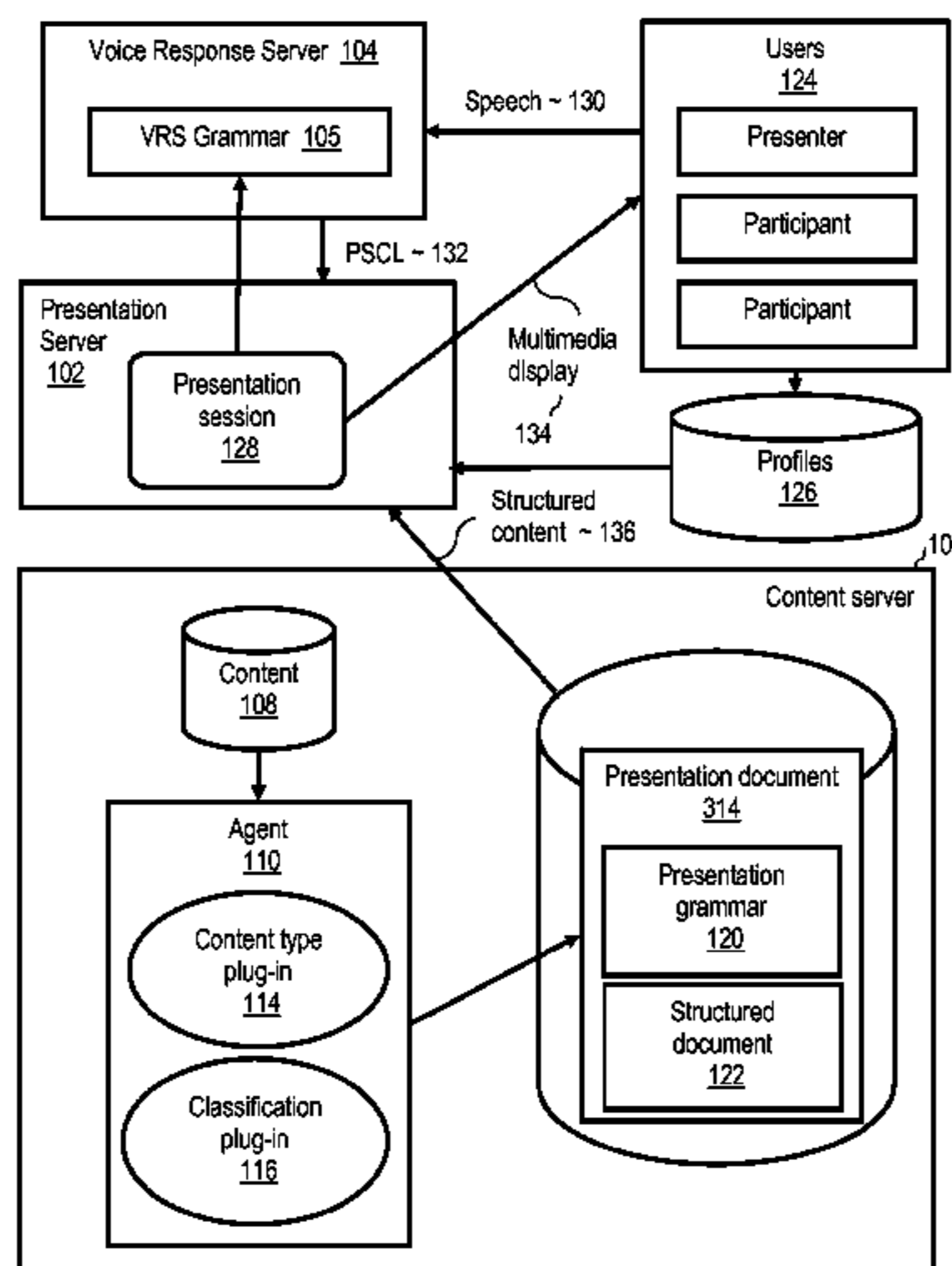

US 7,774,693 B2

U.S. PATENT DOCUMENTS					
			7,287,093 B2	10/2007	Lynch et al.
			7,287,221 B2	10/2007	Bodin et al.
			7,299,405 B1	11/2007	Lee et al.
			7,313,595 B2	12/2007	Rust
			7,334,050 B2	2/2008	Zondervan et al.
			7,395,505 B1	7/2008	Khosla et al.
			7,426,538 B2	9/2008	Bodin et al.
			7,428,698 B2	9/2008	Bodin et al.
			7,430,707 B2	9/2008	Bodin et al.
			7,487,208 B2	2/2009	Bodin et al.
			7,487,209 B2	2/2009	Bodin et al.
			7,487,451 B2	2/2009	Bodin et al.
			7,519,659 B2	4/2009	Bodin et al.
			7,519,683 B2	4/2009	Bodin et al.
			7,519,904 B2	4/2009	Bodin et al.
			7,567,908 B2	7/2009	Bodin et al.
			7,571,380 B2	8/2009	Bodin et al.
			7,634,412 B2	12/2009	Bodin et al.
			2001/0032218 A1	10/2001	Huang
			2001/0041973 A1	11/2001	Abkowitz et al.
			2001/0054048 A1	12/2001	Kelsey
			2002/0032564 A1	3/2002	Ehsani et al.
			2002/0035976 A1	3/2002	Nakamura et al.
			2002/0087416 A1	7/2002	Knutson
			2002/0087974 A1	7/2002	Sprague
			2002/0095454 A1	7/2002	Reed et al.
			2002/0129354 A1	9/2002	Bryan et al.
			2002/0133500 A1	9/2002	Arlein et al.
			2002/0138331 A1	9/2002	Hosea et al.
			2002/0146015 A1*	10/2002	Bryan et al. 370/401
			2002/0147782 A1	10/2002	Dimitrova et al.
			2002/0152301 A1	10/2002	Garrett et al.
			2002/0188451 A1	12/2002	Guerra et al.
			2003/0023435 A1	1/2003	Josephson
			2003/0028871 A1	2/2003	Wang et al.
			2003/0037301 A1	2/2003	Rising, III
			2003/0041238 A1	2/2003	French et al.
			2003/0065712 A1	4/2003	Cheung et al.
			2003/0071833 A1	4/2003	Dantzig et al.
			2003/0099343 A1	5/2003	Dezonno
			2003/0158969 A1	8/2003	Gimson et al.
			2003/0208473 A1	11/2003	Lennon
			2004/0006595 A1	1/2004	Yeh et al.
			2004/0107404 A1	6/2004	Burns et al.
			2004/0141016 A1	7/2004	Fukatsu et al.
			2004/0193425 A1	9/2004	Tomes
			2004/0204979 A1	10/2004	Eisenberg et al.
			2004/0205081 A1	10/2004	Chao
			2004/0205114 A1	10/2004	Kinoshita
			2004/0205132 A1	10/2004	Czerwonka
			2004/0205452 A1	10/2004	Fitzsimons et al.
			2004/0205572 A1	10/2004	Fields et al.
			2004/0205629 A1	10/2004	Rosenholtz et al.
			2005/0025136 A1	2/2005	Anschutz et al.
			2005/0060278 A1*	3/2005	Agapi et al. 707/1
			2005/0131944 A1	6/2005	Patrick et al.
			2005/0132271 A1	6/2005	Bodin et al.
			2005/0132273 A1	6/2005	Bodin et al.
			2005/0132274 A1	6/2005	Bodin et al.
			2005/0132275 A1	6/2005	Bodin et al.
			2005/0154970 A1	7/2005	Bodin et al.
			2005/0154975 A1	7/2005	Bodin et al.
			2005/0165900 A1	7/2005	Bodin et al.
			2005/0171780 A1	8/2005	Schmid et al.
			2005/0240603 A1	10/2005	Bodin et al.
			2005/0240608 A1	10/2005	Jones et al.
			2005/0240859 A1	10/2005	Bodin et al.
			2005/0240909 A1	10/2005	Tersigni
			2006/0010365 A1	1/2006	Bodin et al.
			2006/0010370 A1	1/2006	Bodin et al.
			2006/0014546 A1	1/2006	Bodin et al.
			2006/0015557 A1	1/2006	Bodin et al.
			2006/0080614 A1	4/2006	Lentz
4,941,187 A	7/1990	Slater			
5,119,465 A	6/1992	Jack et al.			
5,181,162 A	1/1993	Smith et al.			
5,327,176 A	7/1994	Forler et al.			
5,388,185 A	2/1995	Terry et al.			
5,428,400 A	6/1995	Landis et al.			
5,649,223 A	7/1997	Freeman			
5,724,416 A	3/1998	Folandare et al.			
5,745,682 A	4/1998	Keenan			
5,748,186 A	5/1998	Raman			
5,748,725 A	5/1998	Kubo			
5,774,879 A	6/1998	Custy et al.			
5,787,175 A	7/1998	Carter			
5,881,373 A	3/1999	Elofsson et al.			
5,901,230 A	5/1999	Walker			
5,917,480 A	6/1999	Tafoya et al.			
5,983,227 A	11/1999	Nazem et al.			
6,029,043 A	2/2000	Ho et al.			
6,049,332 A	4/2000	Boetje et al.			
6,052,730 A	4/2000	Felciano et al.			
6,058,416 A	5/2000	Mukherjee et al.			
6,092,155 A	7/2000	Olnowich			
6,119,147 A	9/2000	Toomey et al.			
6,138,040 A	10/2000	Nicholls et al.			
6,161,112 A	12/2000	Cragun et al.			
6,163,768 A	12/2000	Sherwood et al.			
6,172,640 B1	1/2001	Durst et al.			
6,212,275 B1	4/2001	Akhteruzzaman			
6,243,454 B1	6/2001	Eslambolchi			
6,249,281 B1	6/2001	Chen et al.			
6,266,691 B1	7/2001	Watanabe et al.			
6,269,336 B1	7/2001	Ladd et al.			
6,269,398 B1	7/2001	Leong et al.			
6,304,283 B1	10/2001	Kitagawa			
6,314,402 B1	11/2001	Monaco et al.			
6,324,499 B1	11/2001	Lewis et al.			
6,349,136 B1	2/2002	Light et al.			
6,366,578 B1	4/2002	Johnson			
6,393,460 B1	5/2002	Gruen et al.			
6,446,096 B1	9/2002	Holland et al.			
6,448,980 B1	9/2002	Kumar et al.			
6,452,915 B1	9/2002	Jorgensen			
6,470,384 B1	10/2002	O'Brien et al.			
6,493,671 B1	12/2002	Ladd et al.			
6,505,195 B1	1/2003	Ikeda et al.			
6,636,238 B1	10/2003	Amir et al.			
6,647,531 B2	11/2003	Isaac et al.			
6,658,414 B2	12/2003	Bryan et al.			
6,665,715 B1	12/2003	Houri			
6,681,247 B1	1/2004	Payton			
6,717,593 B1	4/2004	Jennings			
6,725,199 B2	4/2004	Brittan et al.			
6,725,256 B1	4/2004	Albal et al.			
6,766,368 B1	7/2004	Jakobson et al.			
6,799,208 B1	9/2004	Sankaranarayan et al.			
6,819,338 B2	11/2004	Heasman et al.			
6,829,745 B2	12/2004	Yassin et al.			
6,879,958 B1	4/2005	Kojima et al.			
6,931,254 B1	8/2005	Egner et al.			
6,981,263 B1*	12/2005	Zhang et al. 719/310			
7,000,183 B1	2/2006	Crawford, Jr.			
7,003,550 B1*	2/2006	Cleasby et al. 709/205			
7,058,890 B2	6/2006	George et al.			
7,079,712 B1	7/2006	Silverbrook et al.			
7,099,920 B1	8/2006	Kojima et al.			
7,149,694 B1	12/2006	Harb et al.			
7,162,692 B2	1/2007	Bodin et al.			
7,174,557 B2	2/2007	Sanghvi et al.			
7,249,157 B2	7/2007	Stewart et al.			
7,249,315 B2*	7/2007	Moetteli 715/234			
7,283,621 B2	10/2007	Quinton			

2006/0277465 A1 12/2006 Pandit et al.
 2007/0250602 A1 10/2007 Bodin et al.
 2007/0266097 A1 11/2007 Harik et al.
 2008/0172227 A1 7/2008 Bodin et al.
 2008/0177837 A1 7/2008 Bodin et al.
 2008/0177838 A1 7/2008 Bodin et al.
 2008/0177866 A1 7/2008 Bodin et al.
 2008/0178078 A1 7/2008 Bodin et al.
 2008/0235028 A1 9/2008 Bodin et al.
 2008/0259910 A1 10/2008 Bodin et al.
 2008/0263435 A1 10/2008 Bodin et al.
 2008/0282168 A1 11/2008 Bodin et al.
 2009/0037820 A1 2/2009 Bodin et al.
 2009/0048829 A1 2/2009 Bodin et al.
 2009/0099842 A1 4/2009 Bodin et al.

FOREIGN PATENT DOCUMENTS

WO WO 01/24462 A1 4/2001

OTHER PUBLICATIONS

U.S. Appl. No. 10/285,615, filed Oct. 2002, Bates.
 U.S. Appl. No. 12/331,524, filed Dec. 2008, Bodin et al.
 W3C, "XHTML+Voice Profile 1.0," Dec. 21, 2001, pp. 1-20.
 W3C, "Speech Synthesis Markup Language Version 1," Dec. 2, 2002, downloaded pp. 1-36.
 IBM, "IBM WebShere Voice Server 2.0 Implementation Guide," IBM Redbook, May 2002, title page, copyright page, and pp. 251-276 and 291-292.
 Christian, et al. "A Comparison of Voice controlled and Mouse Controlled Web Browsing," Assets 2000, 72-79, Arlington, VA, 2000, downloaded from: <http://citeseer.its.psu.edu/373105.html>, downloaded pages including CiteSeer bibliography, 1-10.
 Karl, et al., "Speech-Activated versus Mouse-Activated Commands for Word Processing Applications: An Empirical Evaluation," Int'l J. Man-Machine Studies, vol. 39, pp. 667-687, 1993, downloaded from <http://hcil.cs.umd.edu/trs/92-09/92-09.html>, downloaded pp. 1-17.
 Damiani, et al. "A Fine-Grained Access Control System for XML Documents," ACM Transactions on Information and System Security, vol. 5, No. 2, May 2002, pp. 169-202.
 Kudo, et al., "XML Document Security based on Provisional Authorization," CSS'00 Athens, Greece, copyright 2000, pp. 87-96.
 Biegel, et al., "SpeedNav: Document Navigation by Voice", University of California, Berkeley, Oct. 9, 2002.
 Goose, et al., "Streaming Speech: A Framework for Generating and Streaming 3-D Text-To-Speech and Audio Presentations to Wireless

PDAs as Specified Using Extensions to SMIL", WWW2002, May 2002, p. 1-16, Honolulu, Hawaii; USA.
 Freire, et al., "Webviews: Accessing Personalized Web Content and Services", Proceedings of the 10th International Conference on World Wide Web, May 2001, ACM Press, p. 576-586, Hong Kong.
 Engelbart; Authorship Provision in Augment; IEEE Cat. No. 84CH2017-2; Spring 1984; p. 465-472; IEEE Comput. Soc. Press, Silver Spring, MD; USA.
 Wensheng, et al; Real-time Content Based Processing of Multicast Video; Cat. No. 98CH36284; 1998; pp. 882-886, vol. 1; IEEE, Piscataway, NJ; USA.
 Kim et al; An Extended Object Composition Model for Distributed Multimedia Services; Cat. No. 98CH36284; Jan. 2002; pp. 279-286, vol. 1; IEEE, Piscataway, NJ; USA.
 Agawa et al. "Image Analysis for Face Modeling and Facial Image Reconstruction" SPIE; 1990; pp. 1184-1197; vol. 1360, pt 2; USA.
 Kim et al.; An Extended Object Composition Model for Distributed Multimedia Supports in World Wide Web; INSPEC AN B9810-6210R-071, C9810-6130M-080; 1997; pp. 159-174; Singapore.
 Capra, et al., "WebContext: Remote Access to Shared Context", ACM International Conference Proceeding Series, vol. 15, Proceedings of the 2001 Workshop on Perceptive User Interfaces, 2001, p. 1-9.
 Corcoran, et al., "Home Network Infrastructure for Handheld/Wearable Appliances", IEEE Transactions on Consumer Electronics, Aug. 2002, vol. 48, Issue 3, p. 490-495.
 Komlodi et al., "Key Frame Preview Techniques for Video Browsing", ACM 2002, pp. 118-125.
 Cruz, et al. "A Visual Approach to Multimedia Querying and Presentation" ACM 1997, pp. 109-119.
 Shumate, "Hyperizons", Google 1997, pp. 1-3.
 Chigona et al., "Contextualized Preview of Image Map Links", ACM 2002, pp. 150-158.
 Rao et al., Evolution of Mobile Location-Based Services. Commun. ACM 46, 12 (Dec. 2003), pp. 61-65.
 Sripanidkulchai, et al., "Efficient content location using interest-based locality in peer-to-peer systems." Infocom 2003. Twenty-Second Annual Joint Conference of the IEEE Computer and Communications Societies. IEEE, vol. 3, pp. 2166-2176, Mar. 30-Apr. 3, 2003.
 Kimbrough et al., "Deontic Logic 2: On Original Generation of Structure in Legal Documents", Proceedings of the 9th International Conference Artificial Intelligence and Law, Jun. 2003, pp. 152-161.
 Adelberg, Brad, "NoDoSE—A Tool for Semi-Automatically Extracting Structured and Semistructure Data from Text Documents", ACM SIGMOD Record, vol. 27, Issue 2, Jun. 1998, pp. 283-294.

* cited by examiner

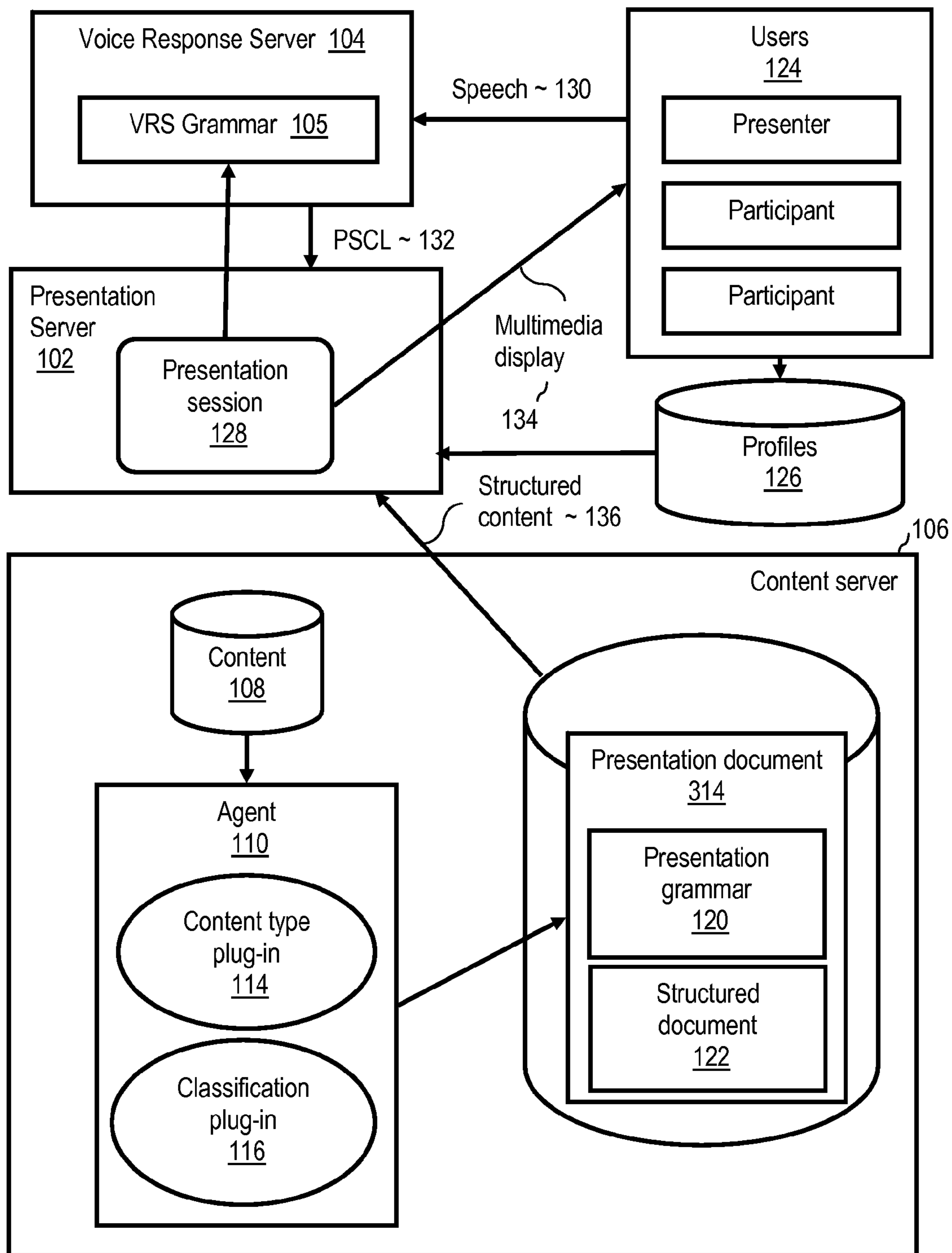

FIG 1

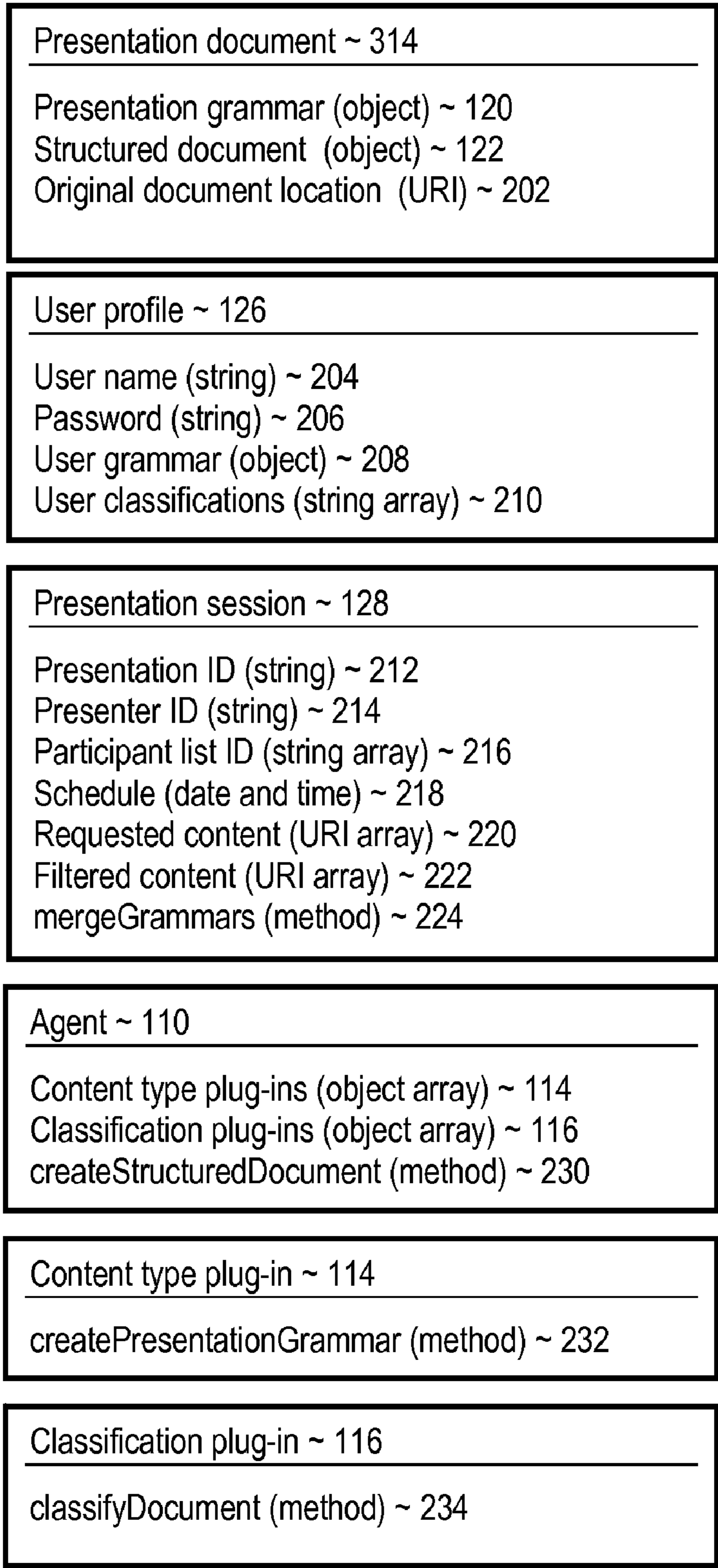

FIG 2

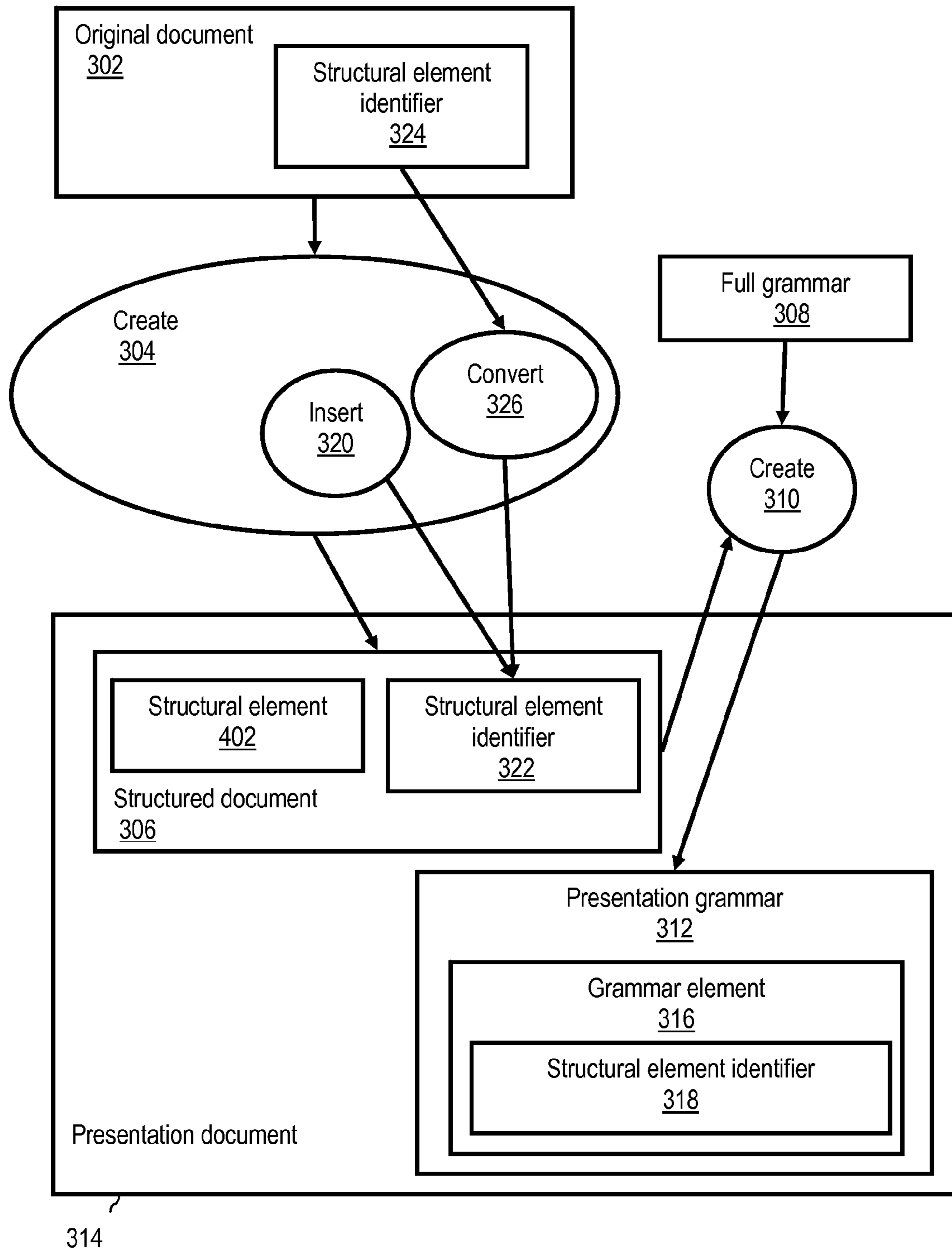

FIG 3

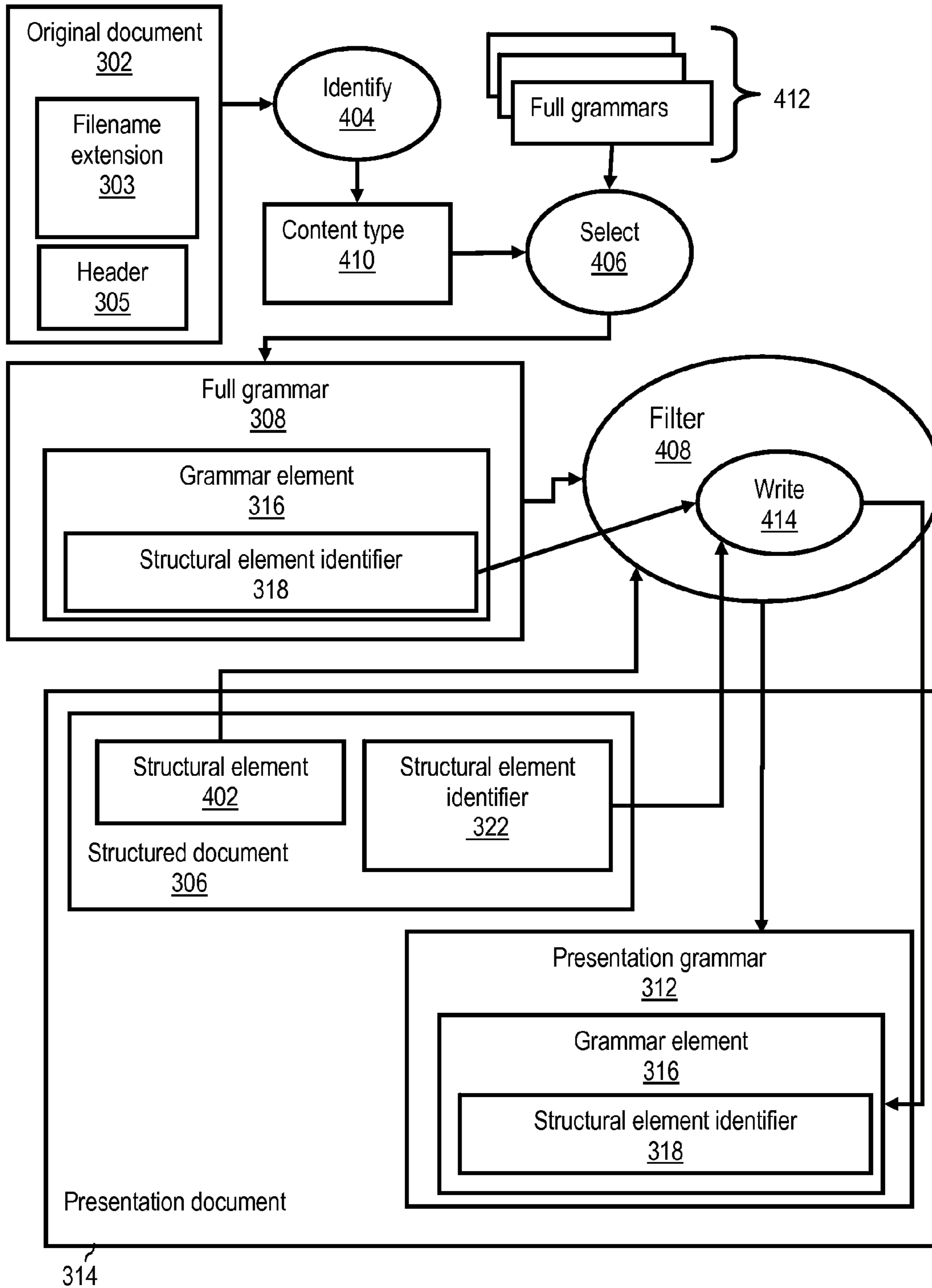

FIG 4

Full Grammar <u>308</u>				
Content Type <u>410</u>	Key Phrase <u>516</u>	Presentation Action Identifier <u>518</u>	Structural Element Identifier <u>318</u>	Parameter <u>520</u>
WP	page down	PgDn	<page>	null
WP	page up	PgUp	<page>	null
WP	go to page	goToPage	<page >	integer
WP	next paragraph	nextParagraph	<paragraph>	null
WP	go to heading	nextHeading	<heading>	string
WP	previous bullet	prevBullet	<bullet>	null
WP	go to subtitle	goToSubtitle	<subtitle>	string

502
504
506
508
510
512
514

FIG 5

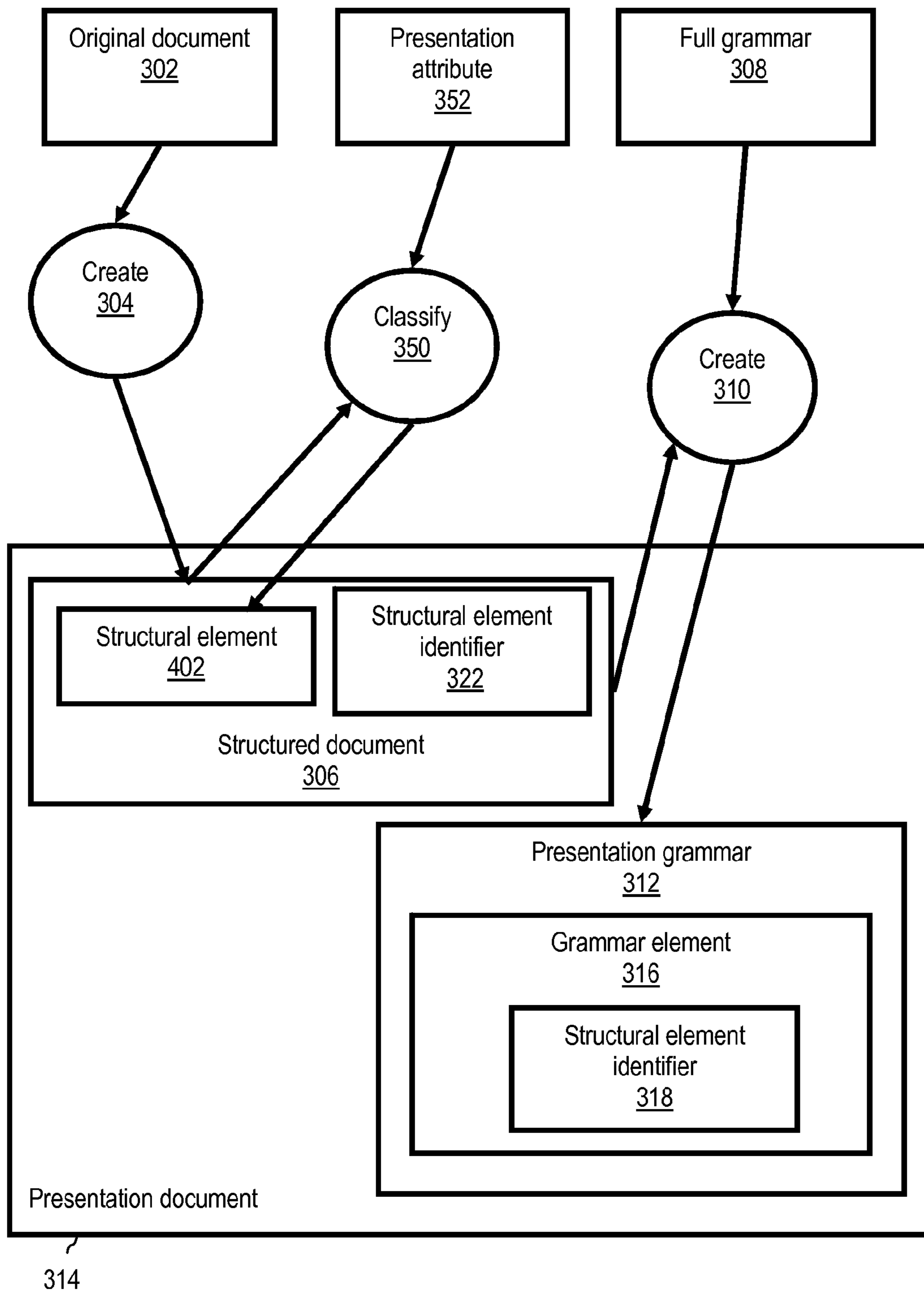

FIG 6

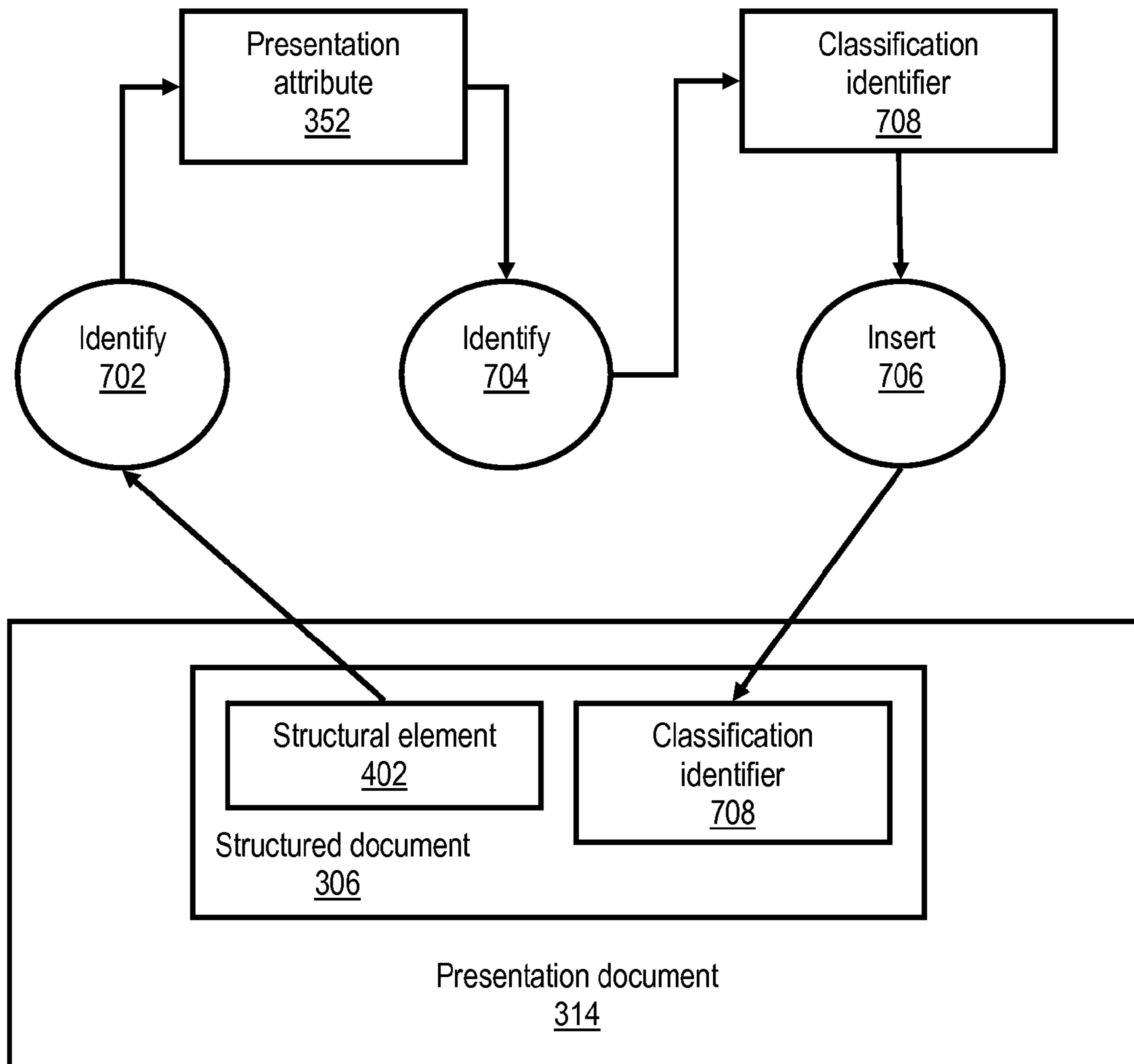
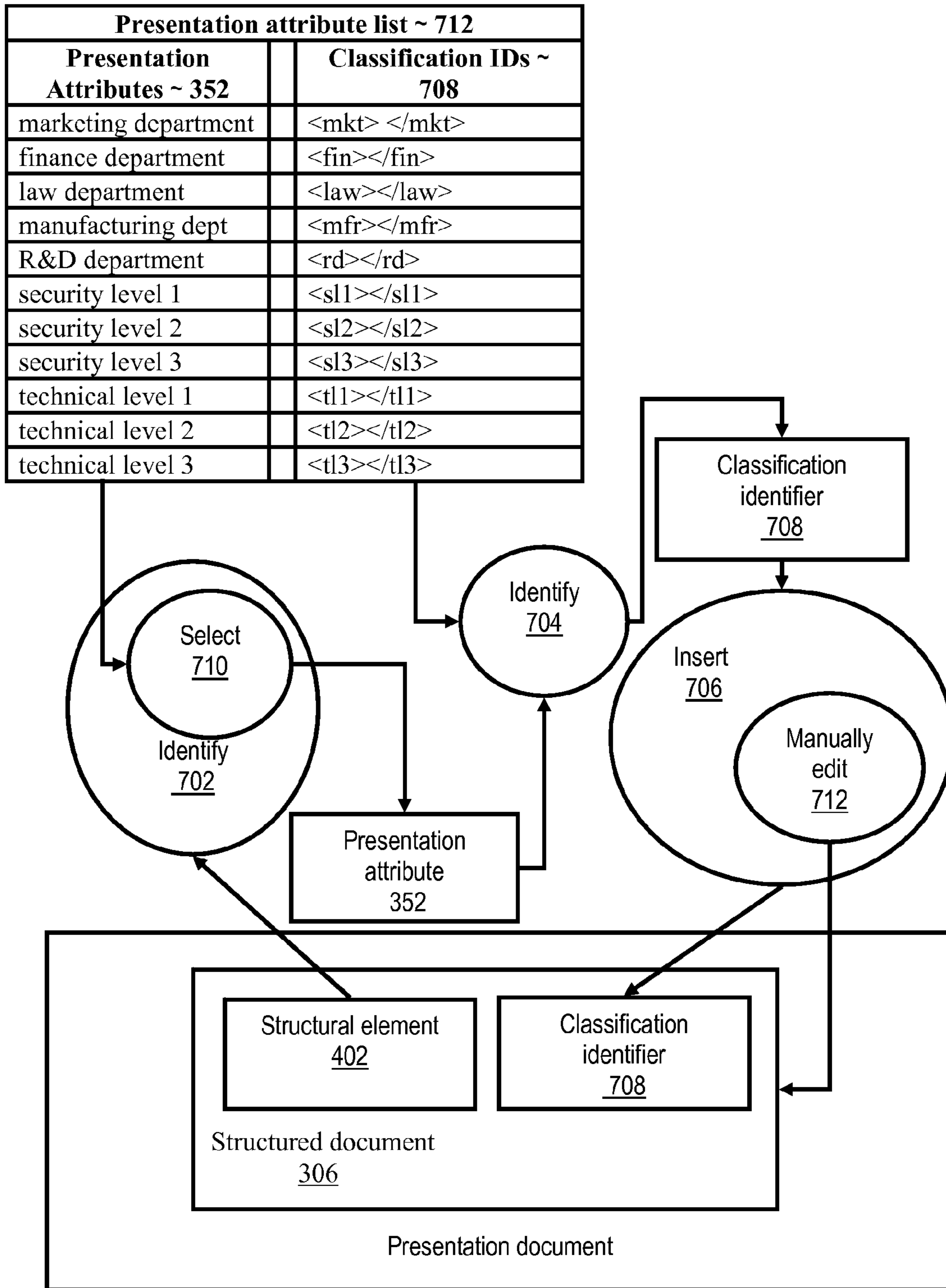

FIG 7



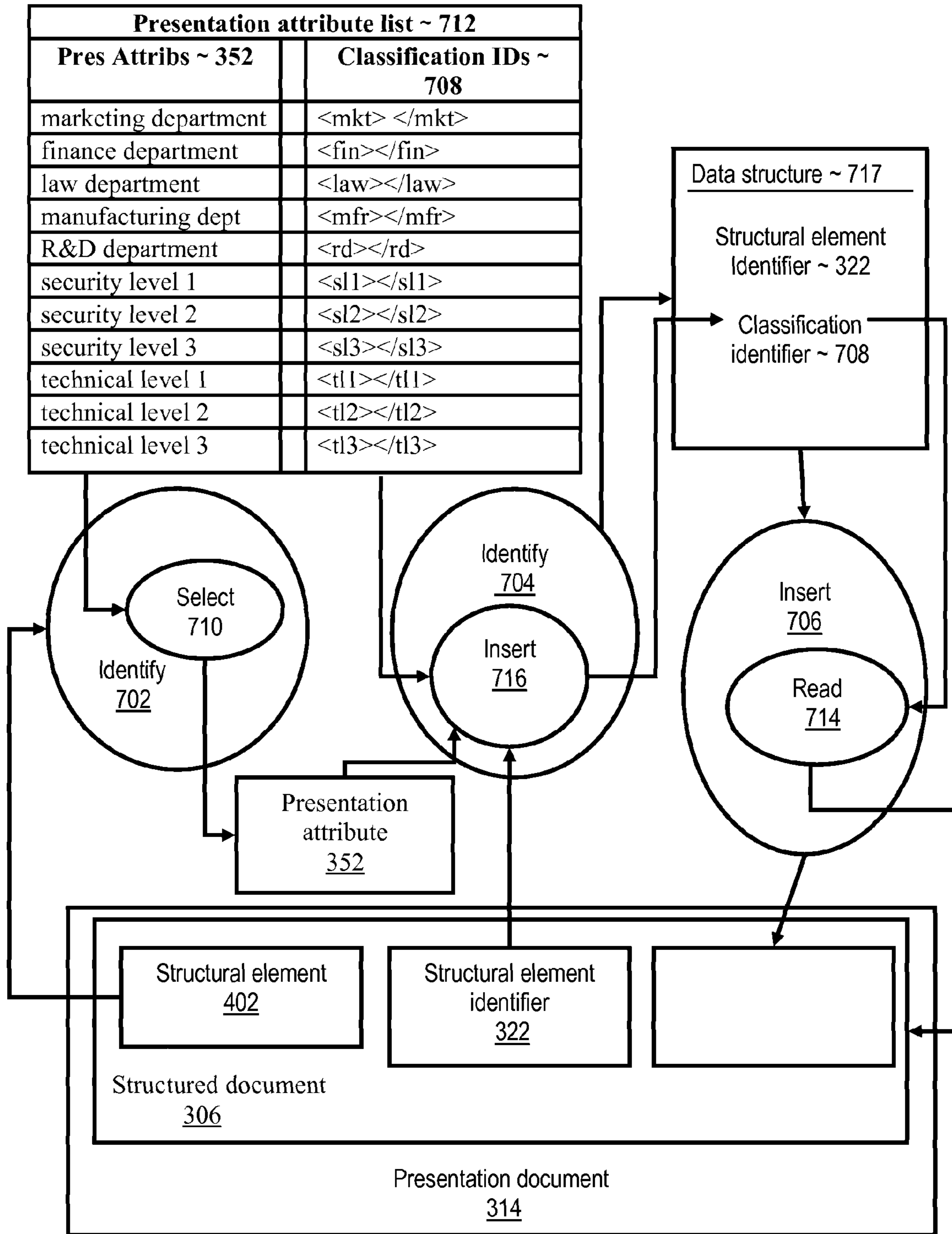
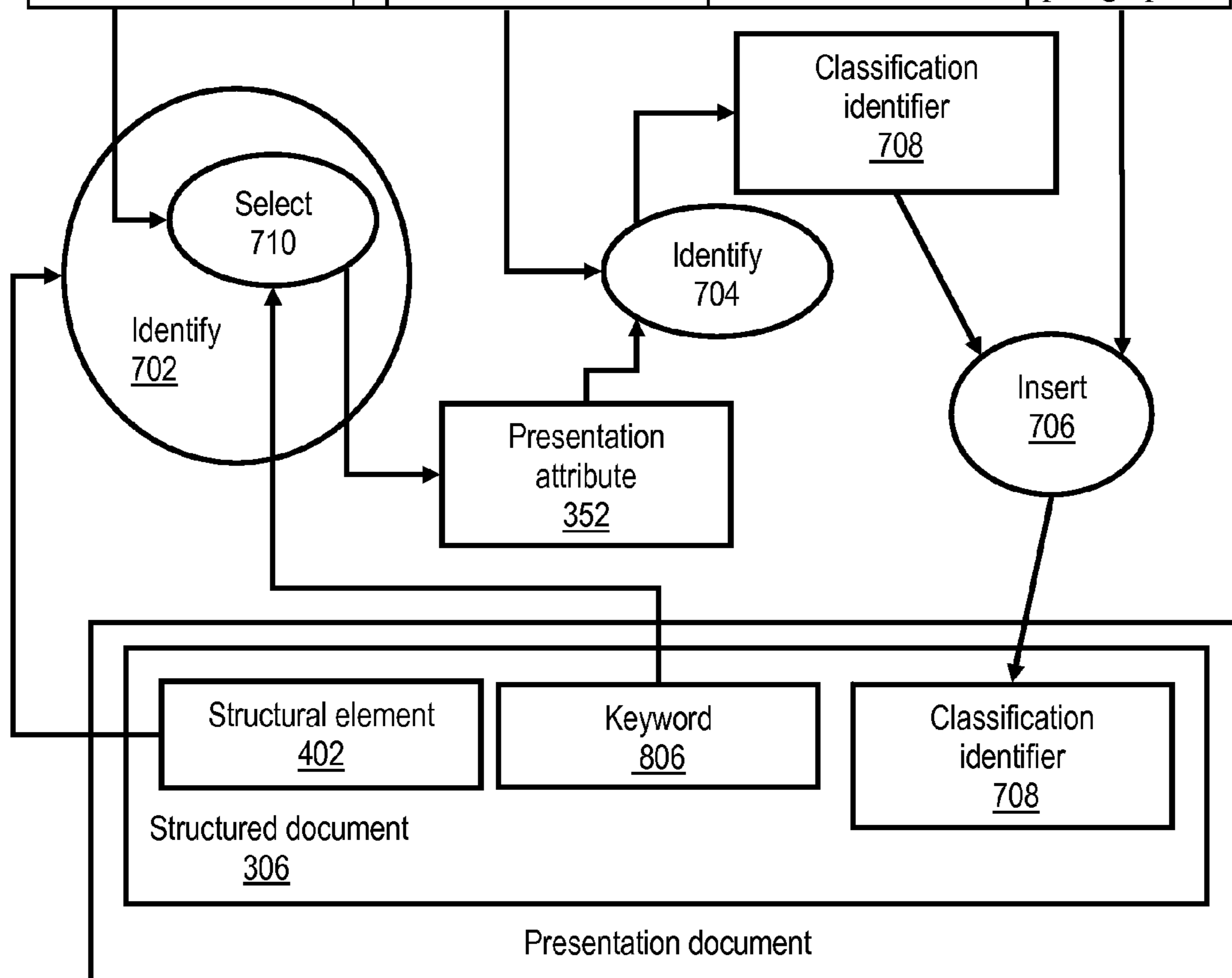
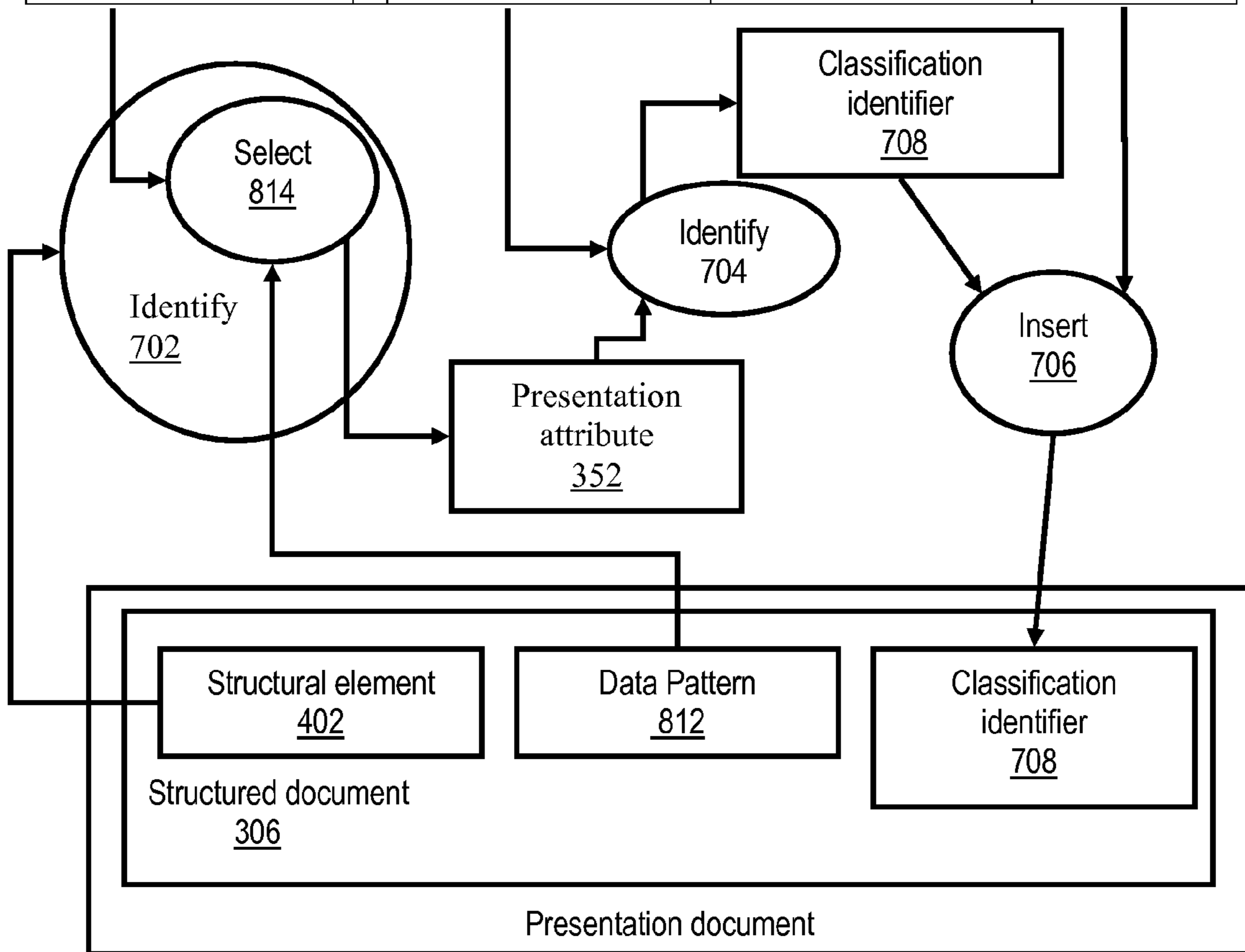

FIG 9

Presentation attribute list ~ 712			
Pres Attribs 352	Classification IDs 708	Keywords 802	Scope 804
finance department	<fin> </fin>	focus	paragraph
finance department	<fin></fin>	accrual	page
finance department	<fin></fin>	production	line
law department	<law></law>	Festo	page
law department	<law></law>	research	page
security level 1	<sl1></sl1>	IBM	page
security level 1	<sl1></sl1>	confidential	page
security level 2	<sl2></sl2>	secret	page
technical level 1	<tl1></tl1>	API	paragraph
technical level 1	<tl1></tl1>	equation	paragraph
technical level 2	<tl2></tl2>	derivative	paragraph



Presentation attribute list ~ 712			
Pres Attribs 352	Classification IDs 708	Data Pattern 810	Scope 804
finance department	<fin> </fin>	focus group	paragraph
finance department	<fin></fin>	cash or accrual	page
finance department	<fin></fin>	production analysis	line
law department	<law></law>	Fcsto estoppel	page
law department	<law></law>	legal research	page
security level 1	<sl1></sl1>	IBM only	page
security level 1	<sl1></sl1>	very confidential	page
security level 2	<sl2></sl2>	highly confidential	page
technical level 1	<t11></t11>	program interface	paragraph
technical level 1	<t11></t11>	e=mc ² f=ma	paragraph
technical level 2	<t12></t12>	dx/dt dv/dt	paragraph



314

FIG. 11

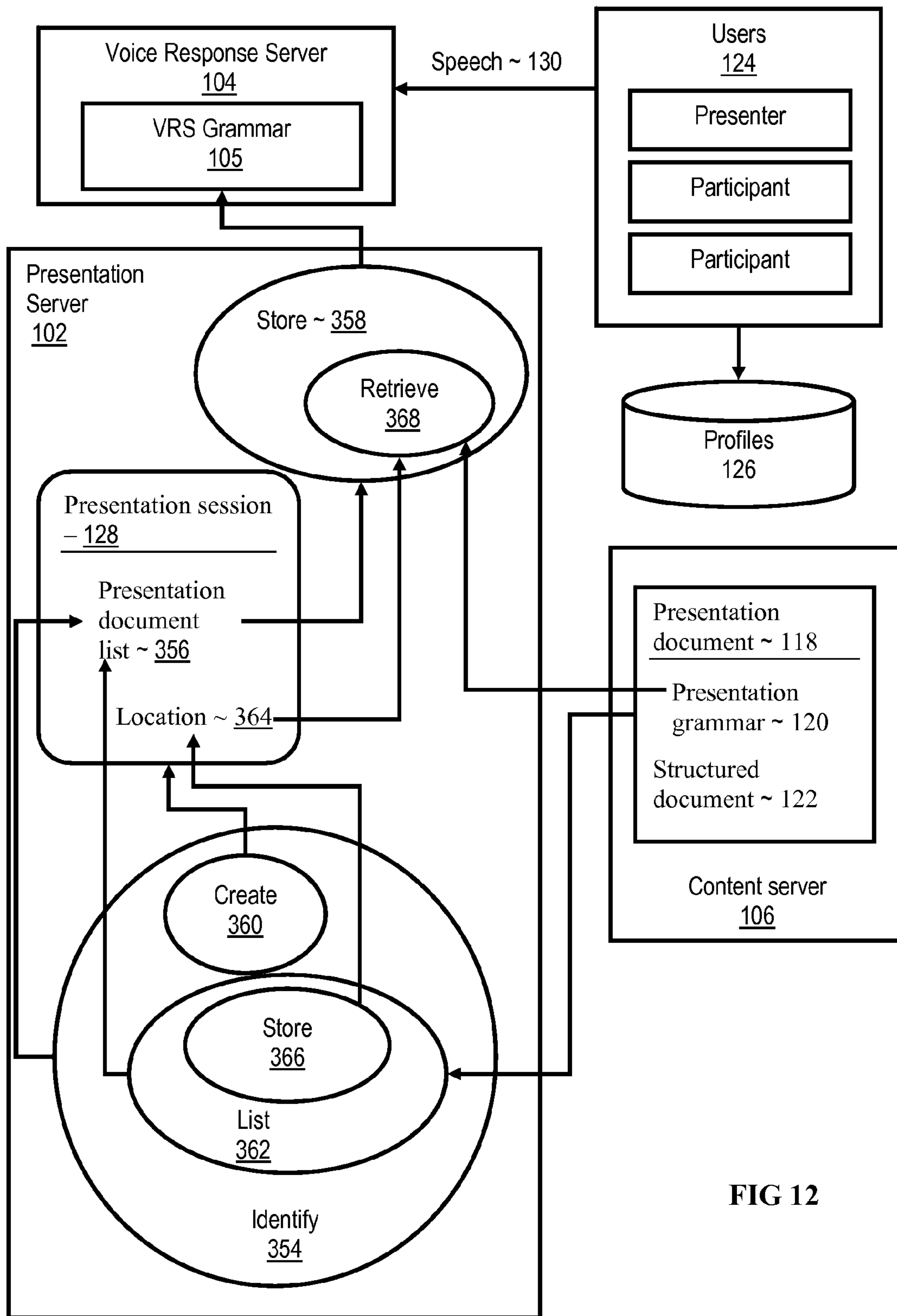

FIG 12

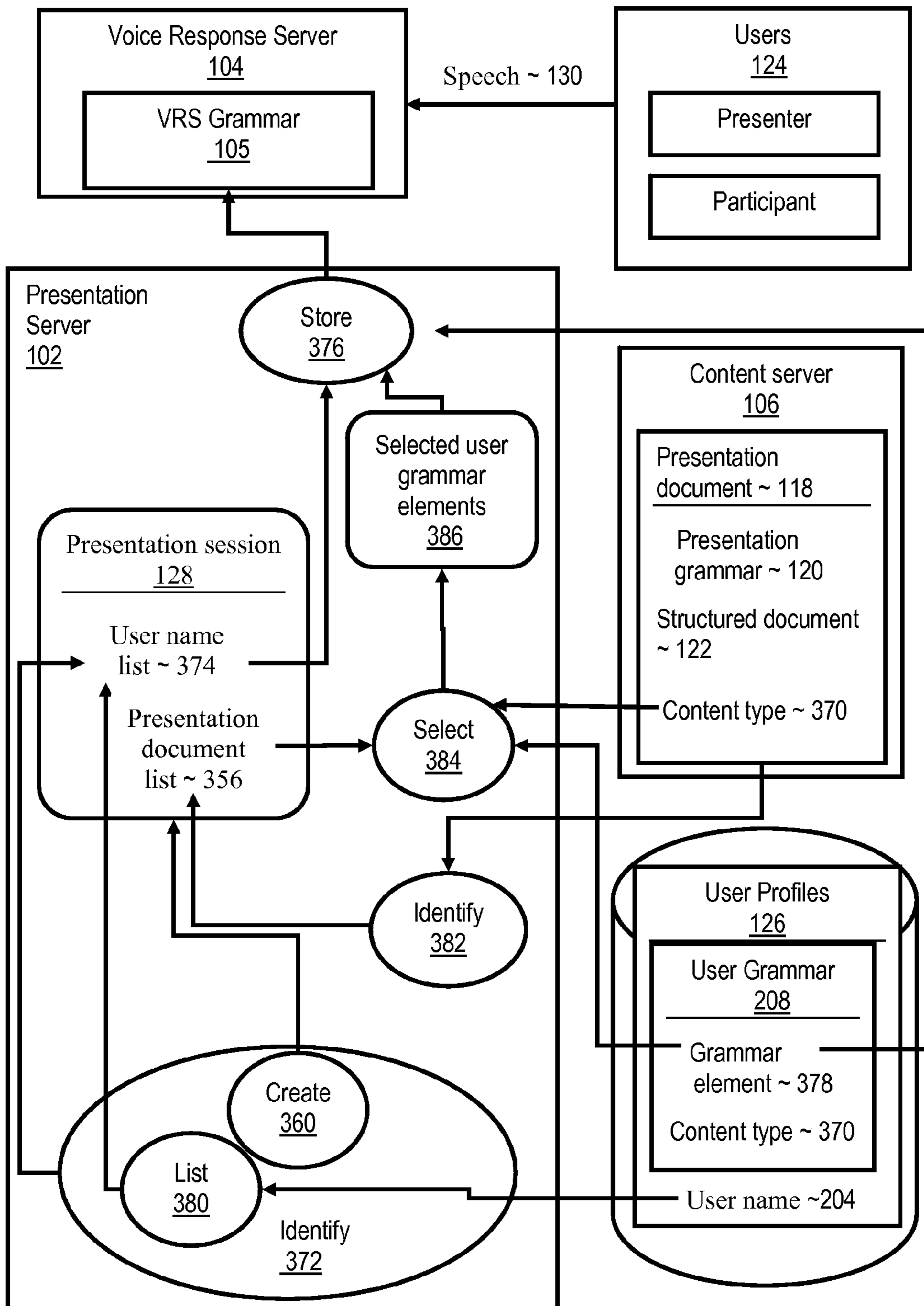

FIG 13

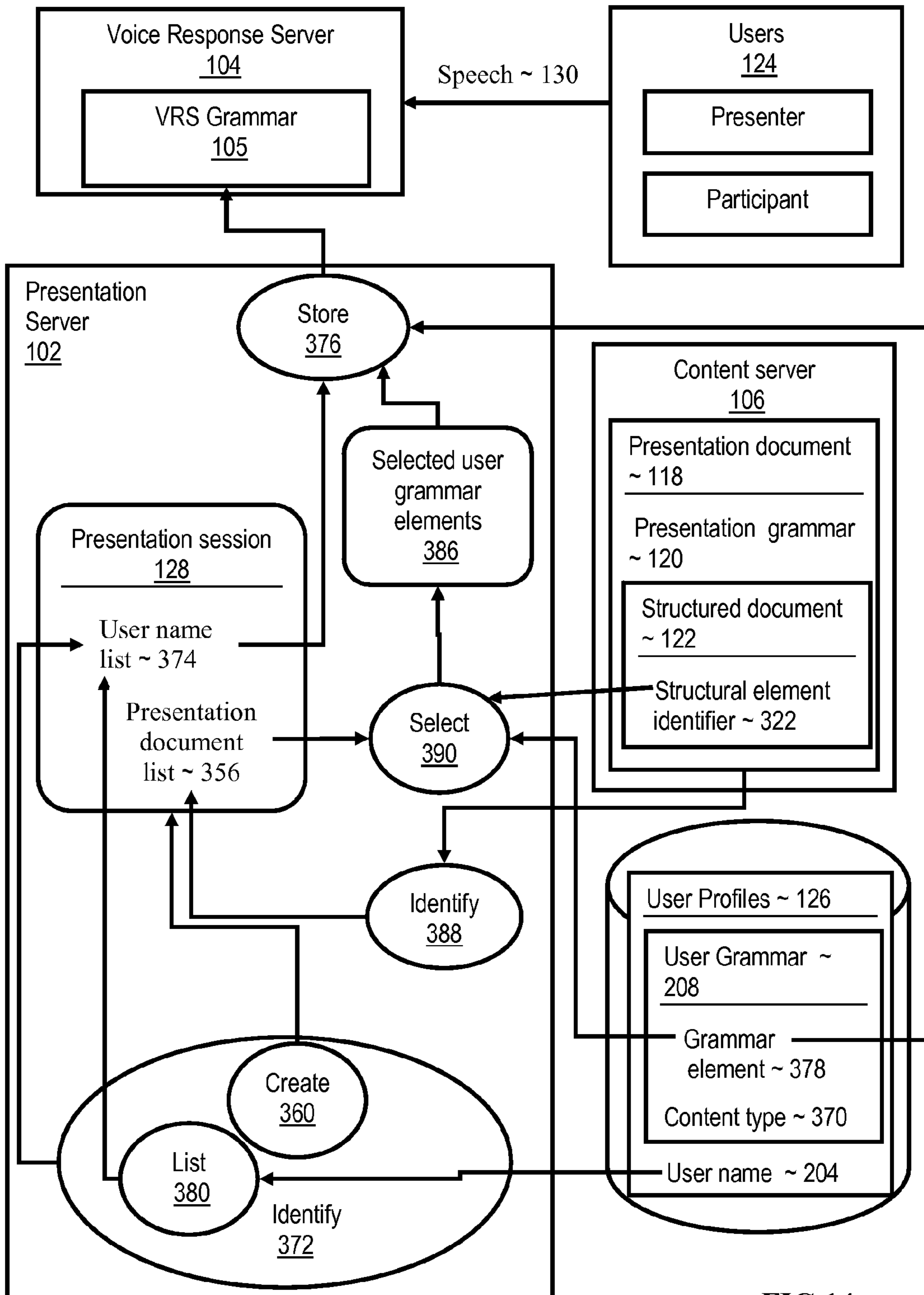

FIG 14

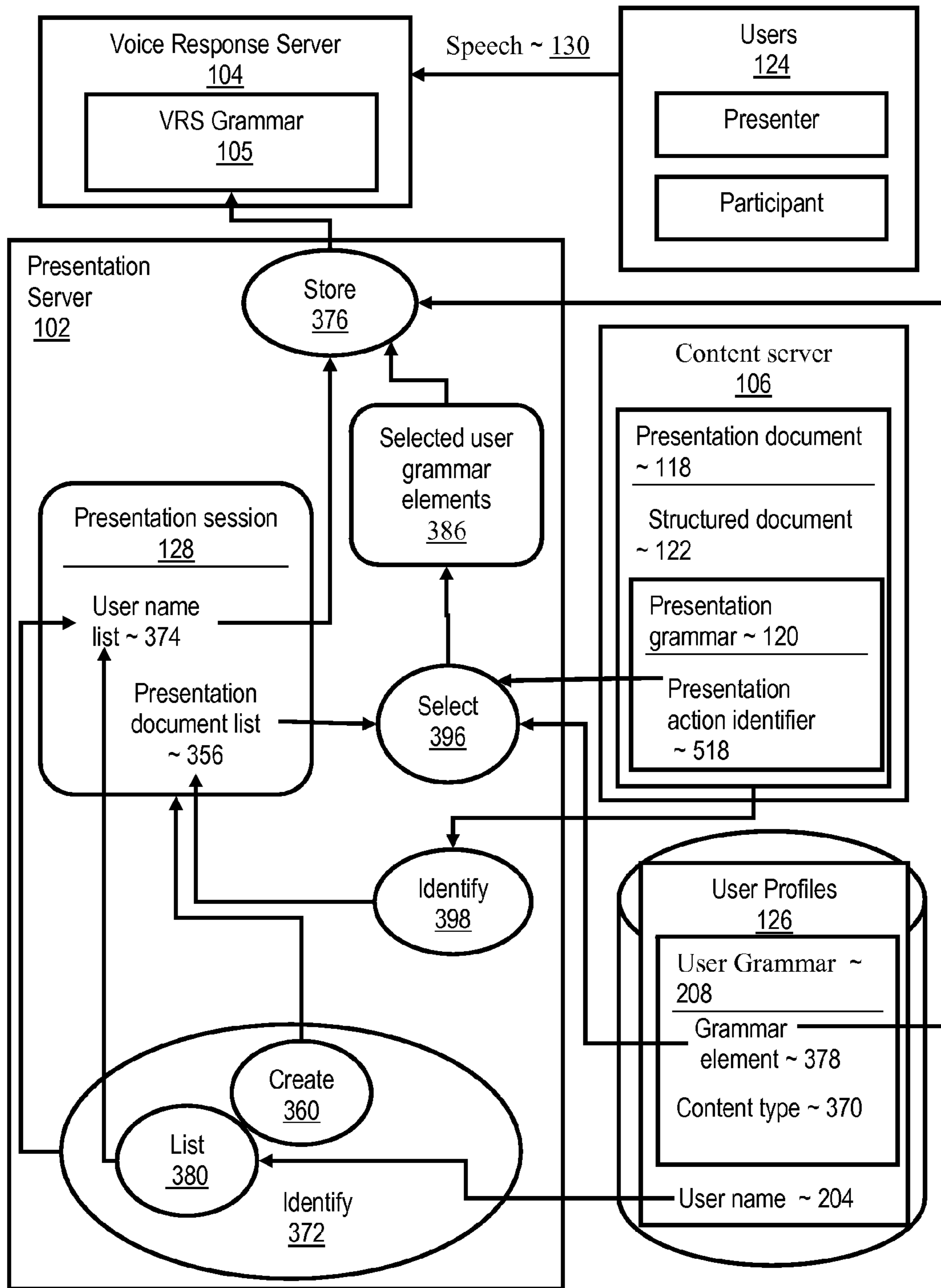

FIG 15

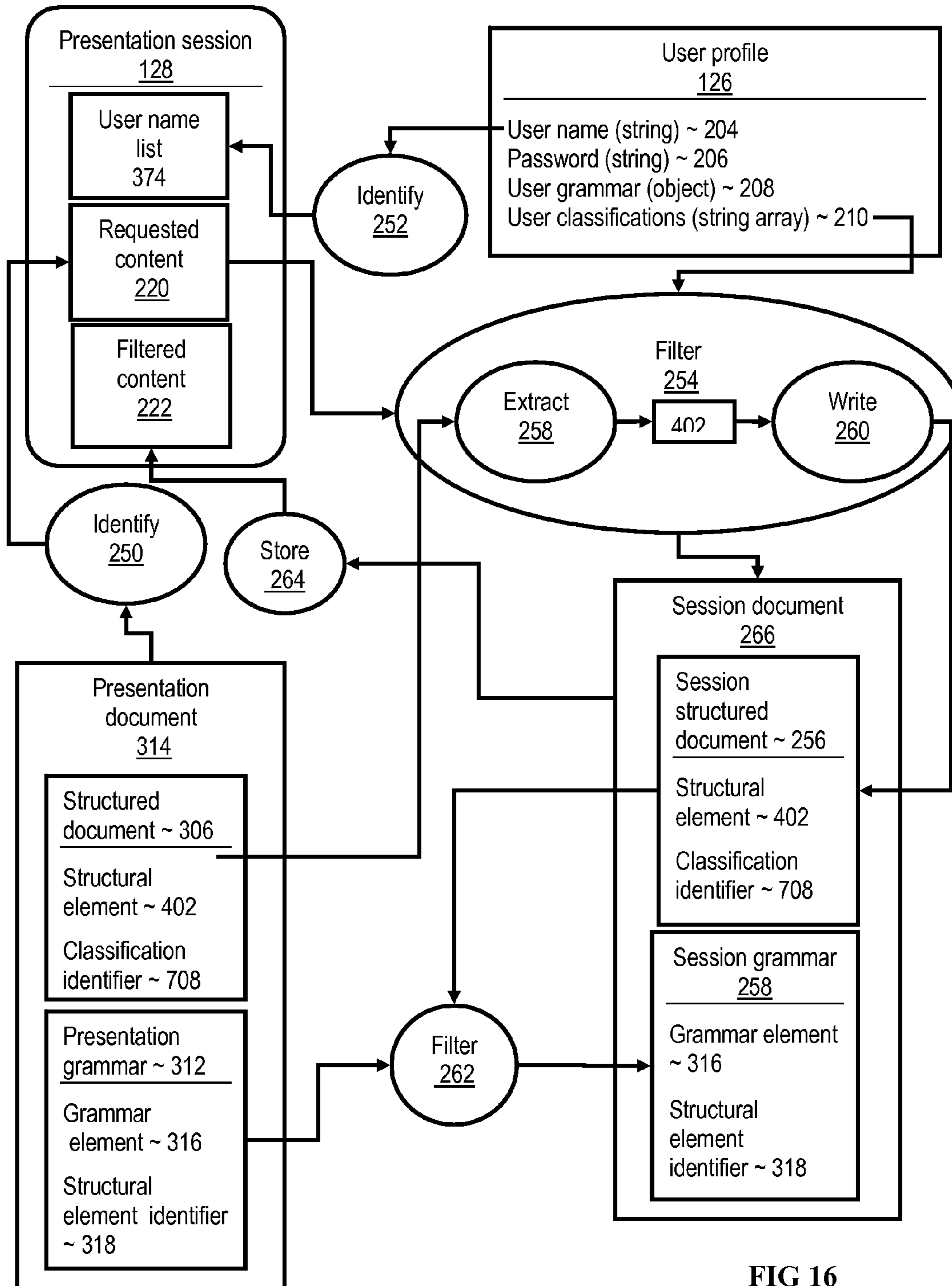

FIG 16

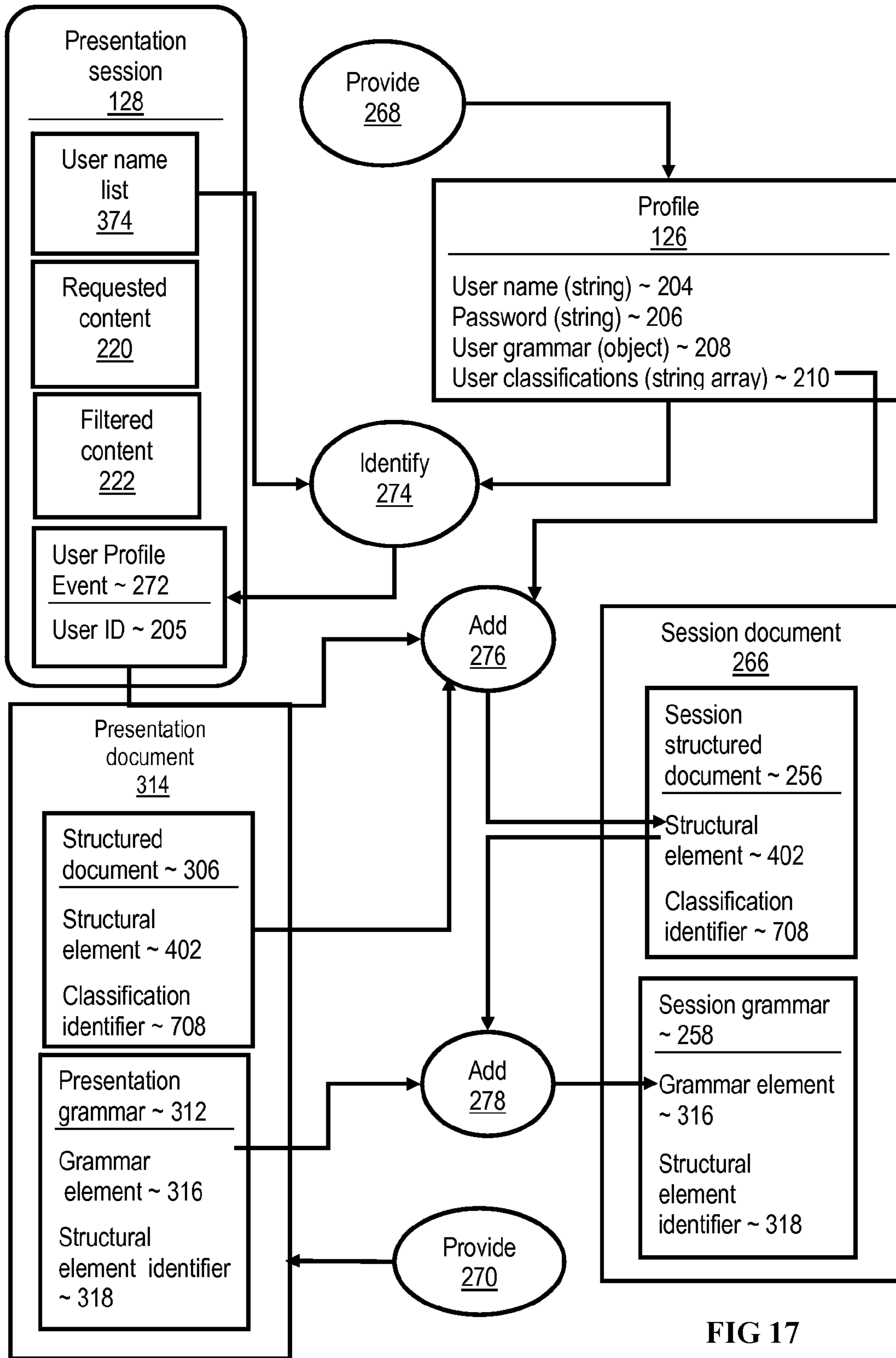

FIG 17

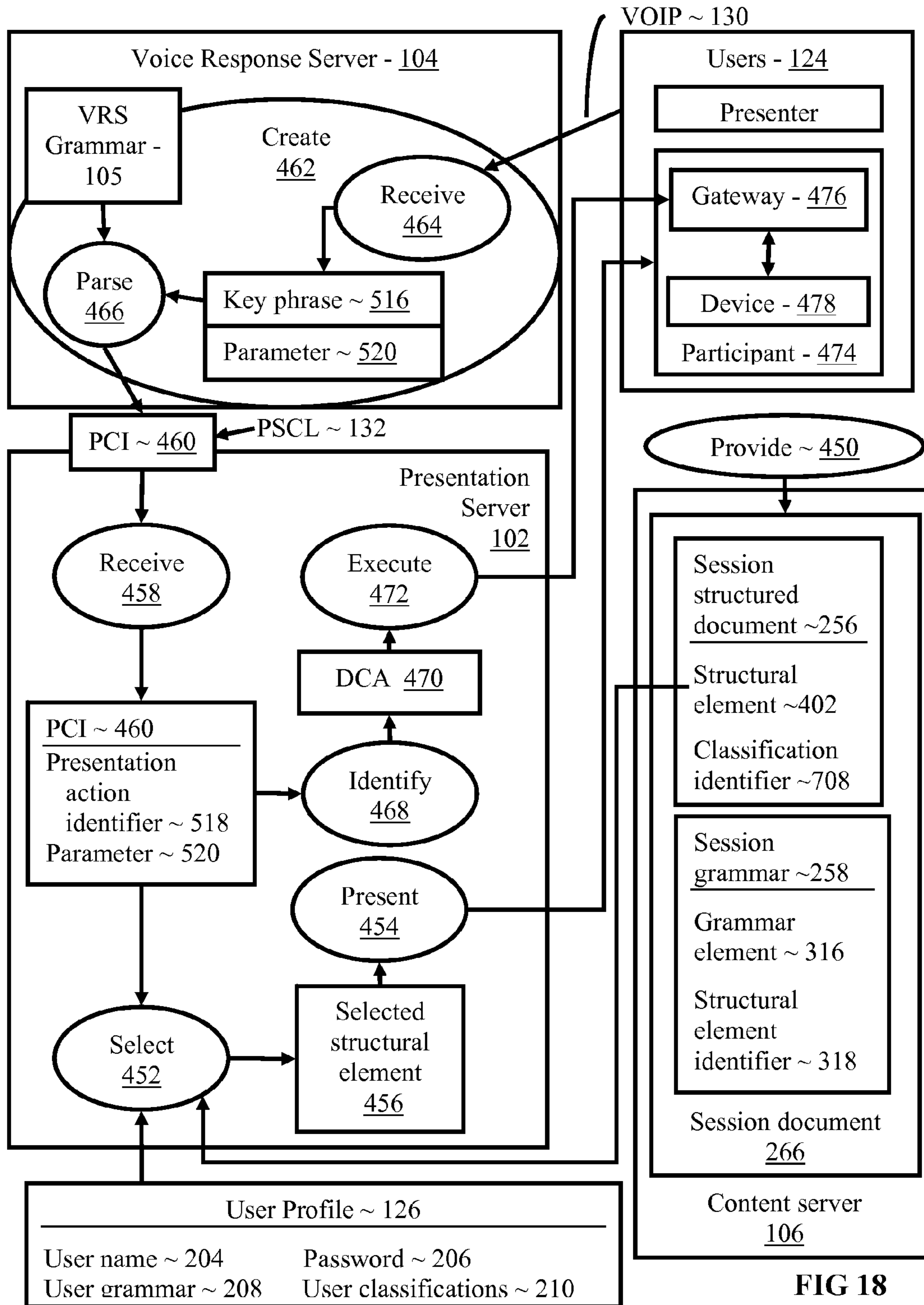

FIG 18

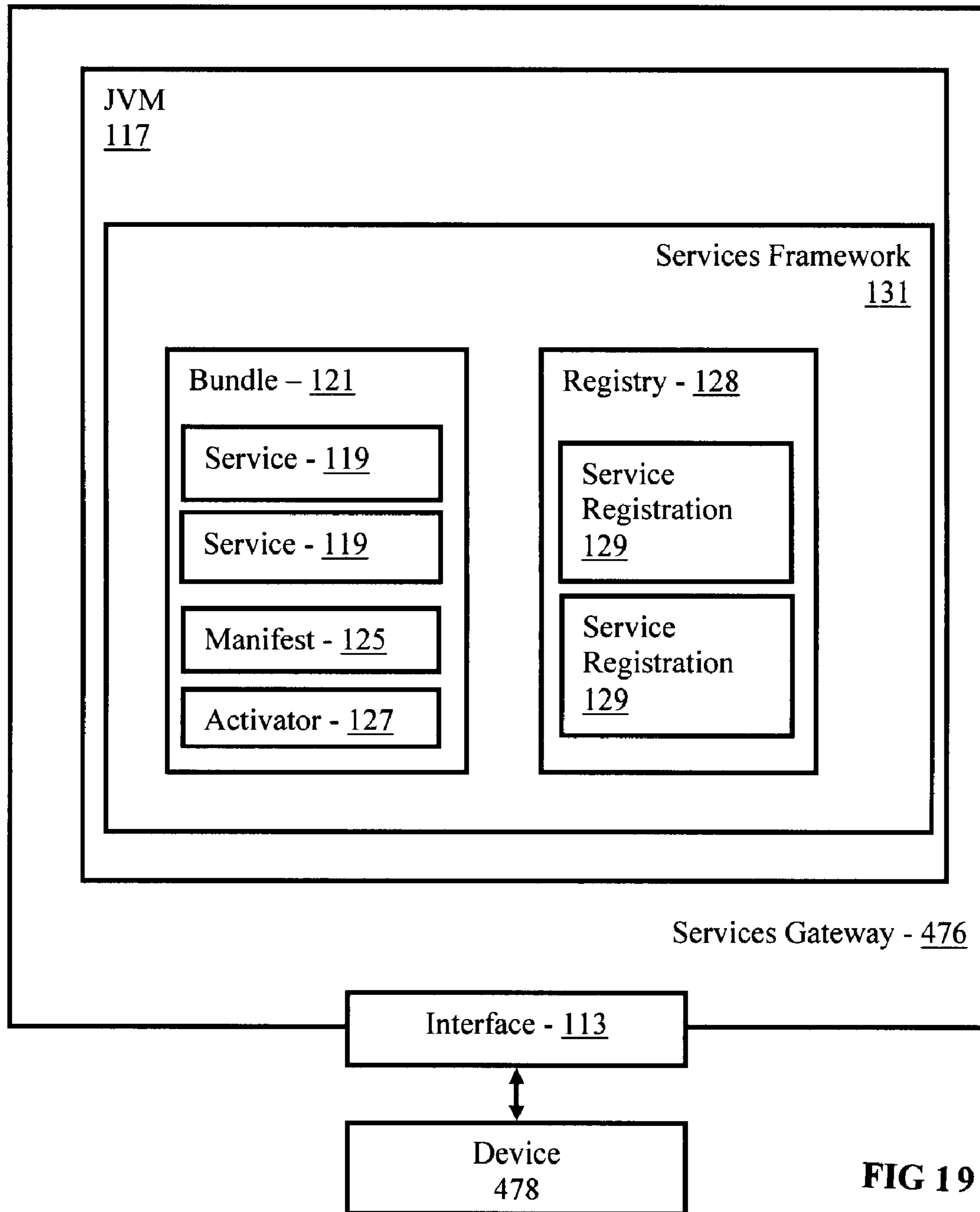

FIG 19

1

DIFFERENTIAL DYNAMIC CONTENT DELIVERY WITH DEVICE CONTROLLING ACTION

CROSS REFERENCE TO RELATED APPLICATION

This application is a continuation application of and claims priority from U.S. patent application Ser. No. 10/756,145 filed on Jan. 13, 2004.

BACKGROUND OF THE INVENTION

1. Field of the Invention

The field of the invention is data processing, or, more specifically, methods, systems, and products for differential dynamic content delivery.

2. Description of Related Art

Multimedia presentations through conferencing systems are becoming more common, but they are inflexible because all conference participants must be presented with exactly the same content. For any particular presentation, however, there is typically a wide variety of participant interest, company, group, or department membership, technical knowledge, security authorization, and so on, across almost any dimension in which participants may vary. Targeting content for such a heterogeneous set of users is typically a manual process today in which presenters create wholly separate presentations for each audience, and the content of each such presentation is reduced to the lowest common denominator of any particular audience. There is a substantial need for improved multimedia presentation systems.

SUMMARY OF THE INVENTION

Methods, systems, and products are disclosed that operate generally to support improved multimedia presentations by creating a presentation document that includes a content-specific presentation grammar and a structured document. The structured document typically has structural elements such as pages, paragraphs, cells, titles, and the like marked with structural identifiers. A content-specific presentation grammar ties presentation actions to the document structure through these structural element identifiers. A presentation actions directs the presentation of a document such as by moving the presentation to the next page of the document, the previous paragraph of the document and so on. A presentation grammar empowers a presenter to invoke the presentation actions using speech.

In typical embodiments, users are assigned classifications describing any attributes of a user, company name, department name, age, gender, technical knowledge, educational level, subject matters of personal interest, security authorization, and so on. Contents of structural elements from structured documents are then filtered for presentation to individual users in a multi-media, multi-user presentation according to the individual attributes of the participants.

In a presentation regarding marketing of a deep space vehicle for a Mars mission, for example, graphic images and paragraphs of text may be developed in many versions, inserted into the same presentation document with each version classified according to technical level, security level, and so on, so that a member of the marketing department viewing the same paragraph at the same time in the same presentation as a member of the research department will in fact be shown a different version of the paragraph. A graphic diagram of a

2

subsystem presented to the marketer will be a simpler version than the one shown at the same time to the researcher.

More particularly, methods, systems, and computer program products are disclosed for differential dynamic content delivery. Typical embodiments include providing a session document for a presentation, wherein the session document includes a session grammar and a session structured document; selecting from the session structured document a classified structural element in dependence upon user classifications of a user participant in the presentation; presenting the selected structural element to the user; identifying a device controlling action; and executing the device controlling action to control a device for the user. In many embodiments, identifying a device controlling action includes identifying a device controlling action in dependence upon a presentation control instruction. In some embodiments, identifying a device controlling action further includes identifying a device controlling action in dependence upon a spoken key word. In some embodiments, identifying a device controlling action further includes identifying a device controlling action in dependence upon a classified structural element. In some embodiments, identifying a device controlling action further includes identifying a device controlling action in dependence upon a classification identifier.

In typical embodiments, executing the device controlling action to control a device for the user includes calling a member method in an OSGi-compliant bundle operating in an OSGi framework on a services gateway. Typical embodiments also include receiving a presentation control instruction, where the presentation control instruction includes a presentation action identifier and one or more optional parameters, and selecting a classified structural element includes selecting a classified structural element in dependence upon the presentation action identifier and the parameters.

Typical embodiments also include creating the presentation control instruction, including receiving from a user participating in the presentation a key phrase and optional parameters for invoking a presentation action; and parsing the key phrase and parameters against a voice response grammar into a presentation control instruction. In many embodiments, selecting a classified structural element further includes selecting a classified structural element having an associated classification identifier that corresponds to the user classification. In some embodiments, presenting the selected structural element to the user further includes selecting a data communications protocol for the presentation; inserting the selected structural element in a data structure appropriate to the data communications protocol; and transmitting the data structure to the user according to the data communications protocol.

Many embodiments also include creating a session document from a presentation document, including identifying a presentation document for a presentation, the presentation document including a presentation grammar and a structured document having structural elements classified with classification identifiers; identifying a user participant for the presentation, the user having a user profile comprising user classifications; and filtering the structured document in dependence upon the user classifications and the classification identifiers. In typical embodiments, filtering the structured document includes extracting, from the structured document, structural elements having classification identifiers corresponding to the user classifications and writing the extracted structural elements into a session structured document in the session document.

Typical embodiments also include filtering the presentation grammar, in dependence upon the extracted structural elements, into a session grammar in the session document. Typical embodiments also include creating a presentation document, including creating, in dependence upon an original document, a structured document comprising one or more structural elements; classifying a structural element of the structured document according to a presentation attribute; and creating a presentation grammar for the structured document, wherein the presentation grammar for the structured document includes grammar elements each of which includes an identifier for at least one structural element of the structured document.

The foregoing and other objects, features and advantages of the invention will be apparent from the following more particular descriptions of exemplary embodiments of the invention as illustrated in the accompanying drawings wherein like reference numbers generally represent like parts of exemplary embodiments of the invention.

BRIEF DESCRIPTION OF THE DRAWINGS

FIG. 1 sets forth a block diagram of an exemplary system architecture in which may be implemented various exemplary embodiments of the present invention.

FIG. 2 sets forth class diagrams for exemplary object oriented classes useful in implementing methods and systems for creating presentation documents according to various exemplary embodiments of the present invention.

FIG. 3 sets forth a data flow diagram illustrating a method for creating a presentation document.

FIG. 4 sets forth a data flow diagram illustrating an exemplary method of creating a presentation grammar.

FIG. 5 sets forth an exemplary data structure in which a full grammar may be implemented according to embodiments of the present invention.

FIG. 6 is a data flow diagram illustrating a further method for creating a presentation document.

FIG. 7 is a data flow diagram illustrating an exemplary method for classifying a structural element.

FIG. 8 sets forth a data flow diagram illustrating an exemplary method for classifying a structural element in a structured document.

FIG. 9 sets forth a data flow diagram illustrating a further exemplary method for classifying a structural element in a structured document.

FIG. 10 sets forth a data flow diagram illustrating another exemplary method for classifying a structural element in a structured document.

FIG. 11 sets forth a data flow diagram illustrating a further exemplary method for classifying a structural element in a structured document.

FIG. 12 sets forth a data flow diagram illustrating an exemplary method for creating a voice response grammar in a voice response server.

FIG. 13 sets forth a data flow diagram illustrating an exemplary method for creating a voice response grammar in a voice response server.

FIG. 14 is a data flow diagram illustrating an alternative exemplary method for creating a voice response grammar in a voice response server.

FIG. 15 is a data flow diagram illustrating another alternative exemplary method for creating a voice response grammar in a voice response server.

FIG. 16 sets forth a data flow diagram illustrating an exemplary method for creating a session document from a presentation document.

FIG. 17 sets forth a data flow diagram illustrating an exemplary method for amending a session document during a presentation.

FIG. 18 sets forth a data flow diagram illustrating an exemplary method for differential dynamic content delivery.

FIG. 19 is a block diagram of an exemplary services gateway useful in executing device controlling actions according to the present invention.

DETAILED DESCRIPTION OF EXEMPLARY EMBODIMENTS

Introduction

The present invention is described to a large extent in this specification in terms of methods for differential dynamic content delivery. Persons skilled in the art, however, will recognize that any computer system that includes suitable programming means for operating in accordance with the disclosed methods also falls well within the scope of the present invention. Suitable programming means include any means for directing a computer system to execute the steps of the method of the invention, including for example, systems comprised of processing units and arithmetic-logic circuits coupled to computer memory, which systems have the capability of storing in computer memory, which computer memory includes electronic circuits configured to store data and program instructions, programmed steps of the method of the invention for execution by a processing unit.

The invention also may be embodied in a computer program product, such as a diskette or other recording medium, for use with any suitable data processing system. Embodiments of a computer program product may be implemented by use of any recording medium for machine-readable information, including magnetic media, optical media, or other suitable media. Persons skilled in the art will immediately recognize that any computer system having suitable programming means will be capable of executing the steps of the method of the invention as embodied in a program product. Persons skilled in the art will recognize immediately that, although most of the exemplary embodiments described in this specification are oriented to software installed and executing on computer hardware, nevertheless, alternative embodiments implemented as firmware or as hardware are well within the scope of the present invention.

Creating a Presentation Document

Methods, systems, and products are now described for creating a presentation document with reference to the accompanying drawings, beginning with FIG. 1. FIG. 1 sets forth a block diagram of an exemplary system architecture in which may be implemented various exemplary embodiments of the present invention. The system of FIG. 1 include a content server (106) having stored content (108) of original documents from which presentation documents are created. Agent (110) includes software modules for creating presentation grammars for presentation documents according to content type (114) and for classifying presentation document content according to presentation attributes (116). Presentation attributes are generic selection criteria for displaying appropriate structural elements of original documents to users. Examples of presentation attributes include users' company names, department names, security levels, technical levels, and so on. User profiles (126) include user classification information typically used to filter presentation media according to presentation attributes.

5

Content server (106) includes storage for presentation documents (314) each of which is composed of a presentation grammar (120) and a structured document (122). A presentation grammar is a data structure that includes a set of key phrases used to identify presentation action identifiers and optional parameters for use in formulating presentation control instructions relevant to structural elements of a content type. In typical embodiments, presentation control instructions are represented by and formulated from presentation action identifiers (reference 518 on FIG. 5). Key phrases are spoken by users and presented as speech input to voice response server (104) where they are parsed and used to select a presentation action identifier (518 on FIG. 5) from a VRS grammar (105). VRS grammar (105) is formed dynamically from presentation grammars (120) in use in a presentation session (128). In some embodiments, VRS grammar (105) is formed dynamically from user grammars from user profiles (126). Presentation Session Control Language (“PSCL”) stream (132) represents a stream of presentation control instructions composed of presentation action identifiers (518 on FIG. 5) and optional presentation control parameters (520 on FIG. 5) from VRS (104) to presentation server (102) which is programmed to present (134) structured multimedia content (136) from structured documents (122) to users (119) in accordance with such presentation control instructions (132).

FIG. 2 sets forth class diagrams for exemplary object oriented classes useful in implementing methods and systems for creating presentation documents according to various exemplary embodiments of the present invention. FIG. 2 includes a presentation document class (314) that includes a reference to a presentation grammar (120), a reference to a structured document (122), and a network location (202) of an original document from which the presentation document was created. In the example of FIG. 2, the network location (202) of the original document is expressed as a Uniform Resource Identifier or “URI.”

FIG. 2 includes a profile class (126) whose objects represent presentation users. The profile class (126) includes a user name (204), a password (206), and a reference to a user grammar (208). A user grammar is a data structure that includes a set of key phrases that are used to select presentation action identifiers specific to a user for use in formulating presentation control instructions. For a presentation control instruction that instructs a presentation session to carry out the presentation action ‘page down,’ for example, an individual user may chose to associate with that presentation control instruction the key phrase “rock and roll” or “boogie on down” or any other key phrase favored by a user as will occur to those of skill in the art. Although these particular examples are somewhat fanciful, in fact, user grammars serve a useful purpose by providing key phrases for presentation control instructions that distinguish normal speech. In a discussion of a word processing document, for example, references to pages and paragraphs may abound, and using a distinctive phrase to invoke presentation control instructions on pages and paragraphs reduces the risk of confusion on the part of a voice response server and a presentation session.

The profile class (126) also includes a string array storing user classifications (210). Examples of user classifications (210) include any supported data codes describing users, including, for example “company=IBM,” “department=marketing,” “technical level=3,” “security level=2,” and others as will occur to those of skill in the art.

FIG. 2 includes a presentation session class (128) whose objects represent presentation sessions. A presentation session represents an aggregation of presentation documents for presentation usually at a set date and time, for a defined set of

6

users including a presenter in charge. The presentation session class (128) includes a presentation identifier code (212), a presenter identification (214), a list of participants (216). The presentation session class (128) also includes a schedule date and time (218) when a presentation is to be presented, a URI array identifying presentation documents (220) requested by a presenter for a presentation session, a URI array identifying presentation documents that have been filtered according to presentation attributes or user classifications (220). The presentation session class (128) also includes a member method named mergeGrammars() (224) that is programmed to read presentation grammars from presentation documents and store them in a VRS grammar on a voice response server for use in parsing key phrases spoken by a presenter and other users into presentation control instructions.

Agent (110) includes software modules for structuring a presentation document according to content type (114) and for classifying presentation document content according to presentation attributes (116).

FIG. 2 includes an exemplary agent class (110) whose objects are used in content servers to create presentation documents. Agent class (110) includes an array of references to content type plug-ins (114) that are used to create presentation grammars for presentation documents according to content type. FIG. 2 also shows a content type plug-in class (114) with a member method named createPresentationGrammar() (232) which in this example is programmed to create presentation grammars for presentation documents according to content type. Agent class (110) also includes an array of references to classification plug-ins (116) that are used to classify presentation document content according to presentation attributes (116). FIG. 2 also shows a classification plug-in class (116) with a member method named classifyDocument() (234) which in this example is programmed to classify presentation document content according to presentation attributes.

Agent class (110) also includes a member method named createStructuredDocument() (232) which is programmed to convert an original document into a structured document by inserting structural element identifiers. Examples of structural element identifiers include <page>, <paragraph>, <row>, <column>, <cell>, <slide>, <jpeg>, <title>, <heading>, <subheading>, and so on, as will occur to those of skill in the art. These examples of structural elements identifiers are expressed as markup tags such as would be used, for example, in a markup language such as HTML (“HyperText Markup Language”) or XML (“eXtensible Markup Language”), although this is not a limitation of the invention. In fact, it is well within the scope of the present invention to implement structural element identifiers with binary codes, Unicode identifiers, or by use of other structure identifiers as will occur to those of skill in the art.

FIG. 3 sets forth a data flow diagram illustrating a method for creating a presentation document (314) that includes creating (304), in dependence upon an original document (302), a structured document (306) comprising one or more structural elements (402). In the method of FIG. 3, creating (304) a structured document (306) is carried out by inserting (320) in the structured document (306) structural element identifiers (322) for the structural elements (402). An alternative method of creating a structured document, also shown in FIG. 3, is carried out by converting (326) existing structural element identifiers (324) from the original document (302) to structural element identifiers (322) for the structural elements (402) of the structured document (306). The method of FIG. 3 also includes creating (310) a presentation grammar (312)

for the structured document (306). In the example of FIG. 3, the presentation grammar (312) for the structured document (306) includes grammar elements (316) each of which includes a structural element identifier (318) for at least one structural element (402) of the structured document (306).

FIG. 4 sets forth a data flow diagram illustrating an exemplary method of creating a presentation grammar (312) for a structured document (314) that includes identifying (404) the content type (410) of the original document (302). Identifying the content type may be carried out, for example, by identifying the content type in dependence upon a filename extension (303) in the filename of an original document. Examples of filename extension identifying content type include 'pdf' for Adobe's Portable Document Format, 'xls' for a Microsoft Excel™ spreadsheet, 'doc' for a word processing document, 'xml' for an XML document, and so on, as will occur to those of skill in the art. Alternatively, identifying the content type may be carried out by identifying the content type in dependence upon document header elements in an original document (302). The following is an example of an HTML header identifying an original document having content type HTML version 4.01:

```
<!DOCTYPE HTML PUBLIC "-//W3C//DTD HTML
4.01//EN" "http://www.w3.org/TR/html4/strict.dtd">
```

The method of FIG. 4 includes selecting (406), in dependence upon the content type (410), a full presentation grammar (308) from among a multiplicity of full presentation grammars (412). A full presentation grammar may be implemented, for example, as shown in FIG. 5. A multiplicity of full presentation grammars may be implemented in a data structure similar to the one shown in FIG. 5 by adding a content type column. FIG. 5 sets forth an exemplary data structure (308) in which a full grammar may be implemented according to embodiments of the present invention. The full grammar of FIG. 5 includes several grammar elements (502-514) for a content type. In this example, the content type is taken as a word processing document having structural elements that include pages, paragraphs, bullets, titles, subtitles, and so on, and the data structure includes a column for an identifier (318) of a structural element, a column for a key phrase (516) for formulating a presentation control instruction for invoking a presentation action, and a column for a presentation action identifier (518) representing a presentation action. The exemplary data structure of FIG. 5 also includes a column for a data indication whether a presentation control instruction requires a parameter. The exemplary grammar entries for presentation action identifiers PgDn (502), PgUp (504), nextParagraph (508), and prevBullet (512) have parameter (520) values of 'null,' signifying that a voice response server parsing their key phrases into presentation control instructions is not to parse a parameter for a presentation control instruction. The exemplary grammar entries for presentation action identifiers goToPage (506), nextHeading (510), and goToSubtitle (514), however, have parameter (520) values of 'integer' and 'string,' signifying that a voice response server parsing their key phrases into presentation control instructions is to seek to parse for each of them respectively an integer parameter, a string parameter, and a string parameter.

The method of FIG. 4 includes filtering (408) the full presentation grammar (308) into a presentation grammar (312) for the structured document (306) in dependence upon the structural elements (402) of the structured document (306). Filtering (408) the full presentation grammar (308) may be carried out by writing (414) from the full presentation grammar (308) to the presentation grammar (312) for the structured document (306) each grammar element (316) having a structural element identifier (318) of a structural ele-

ment (402) that occurs in the structured document (306). Using the exemplary full grammar of FIG. 5, for example, to create a presentation grammar for a structured document having structural elements including pages, paragraphs, headings, and subtitles but no bullet points identified in it as structural elements, filtering (408) the full presentation grammar (308) by writing (414) to the presentation grammar (312) grammar elements (502-510) plus grammar element (514) but excluding grammar element (512).

Methods of creating presentation documents are further explained with an exemplary use case. Consider the following example of a structured document:

```
<document>
  <page id="1">
    <p id="1">a paragraph</p>
    <p id="2">another paragraph</p>
    <image id="1">a graphic image</image>
  </page>
  <page id="2">
    <p id="3">a paragraph</p>
    <p id="4">another paragraph</p>
    <image id="2">another graphic image</image>
  </page>
</document>
```

And assume that this exemplary structured document is associated in a presentation document with the following presentation grammar:

TABLE 1

Key Phrase	Presentation Grammar		
	Presentation Action Identifier	Structural Element Identifier	Parameter
page down	PgDn	<page>	null
page up	PgUp	<page>	null
go to page	goToPage	<page>	integer
next paragraph	nextParagraph	<p>	null
go to paragraph	goToParagraph	<p>	integer
next image	nextImage	<image>	null
go to image	goToImage	<image>	integer

This example is discussed with reference to the exemplary system architecture of FIG. 1. In this example, then, when a presentation session (128) displays the first page of the structured document and a user (119) speaks the words "page down," a voice response server (104), having this presentation grammar as part of its VRS grammar (105), parses the speech into a presentation control instruction having a presentation control identifier named "PgDn" and communicates the presentation control instruction through a presentation interface (132) to the presentation session in presentation server (102) which then displays the next page, in this example, page 2 of the example structured document. Similarly, when the first page of the structured document is on display, a user's speaking the words "go to paragraph 4" results in the presentation session's changing the display to show paragraph 4 on the second page of the document. And, when the first page is on display for the users participating in the presentation and a

user speaks the words “next image,” the presentation session changes the display to show image 2 on the second page of the document.

Classifying Structure Elements in a Presentation Document

FIG. 6 is a data flow diagram illustrating a further method for creating a presentation document (314). The method of FIG. 6 includes creating (304), in dependence upon an original document (302), a structured document (306) comprising one or more structural elements (402), as explained in detail above. The method of FIG. 6 also includes classifying (330) a structural element (402) of the structured document (306) according to a presentation attribute (352). FIG. 7 is a data flow diagram illustrating an exemplary method for classifying a structural element that includes identifying (702) a presentation attribute (352) for the structural element (402); identifying (704) a classification identifier (708) in dependence upon the presentation attribute (352); and inserting (706) the classification identifier (708) in association with the structural element (402) in the structured document (306). The method of FIG. 6 also includes creating (310) a presentation grammar (312) for the structured document (306), wherein the presentation grammar (312) for the structured document (306) includes grammar elements (316) each of which includes an identifier (318) for at least one structural element (402) of the structured document (306).

FIG. 8 sets forth a data flow diagram illustrating an exemplary method for classifying a structural element in a structured document in which identifying (702) a presentation attribute (352) for the structural element (402) includes selecting (710) a presentation attribute (352) from a list (712) of supported presentation attributes (352). The presentation attribute list (712) of FIG. 8 includes two columns, one column for presentation attributes (352) and another column for associated classification identifiers (708). In the method of FIG. 8, identifying (704) a classification identifier (708) is carried out by identifying a classification identifier (708) associated with the presentation attribute (352) on the list (712). In the method of FIG. 8, inserting (706) the classification identifier (708) includes manually editing (712) the structured document (306) to insert classification identifiers in appropriate locations to classify structural elements in a structured document. For example, a paragraph to be viewed only by members of the marketing department may be classified by tagging the paragraph with `<mkt></mkt>`.

FIG. 9 sets forth a data flow diagram illustrating a further exemplary method for classifying a structural element in a structured document in which identifying (702) a presentation attribute (352) for the structural element (402) includes selecting (710) a presentation attribute (352) from a list (712) of supported presentation attributes (352), the presentation attribute (352) having an associated classification identifier (708). In the method of FIG. 9, identifying (704) a classification identifier (708) includes inserting (716) the classification identifier (708) in a data structure (717) in association with a structural element identifier (322) for the structural element (402). In the method of FIG. 9, inserting (706) the classification identifier (708) in the structured document (306) includes reading (714) the classification identifier (708) from the data structure (717) in dependence upon the structural element identifier (322).

FIG. 10 sets forth a data flow diagram illustrating another exemplary method for classifying a structural element in a structured document that includes providing a list (712) of supported presentation attributes (352) including at least one

keyword (802) and at least one indication of structural insertion scope (804) for each presentation attribute (352). In the method of FIG. 10, identifying (702) a presentation attribute (352) for the structural element (402) includes selecting (710) a presentation attribute (352) from the list (712) in dependence upon a keyword (806) from the structured document (306). In the method of FIG. 10, identifying (704) a classification identifier (708) is carried out by identifying a classification identifier (708) associated with the presentation attribute (352) on the list (712). In the method of FIG. 10, inserting (706) the classification identifier (708) is carried out by inserting the classification identifier (708) in the structured document (306) according to a structural insertion scope (804) for the selected presentation attribute (352).

FIG. 11 sets forth a data flow diagram illustrating a further exemplary method for classifying a structural element in a structured document that includes providing a list (712) of supported presentation attributes (352) including at least one data pattern (810) and at least one indication of structural insertion scope (804) for each presentation attribute (352). In the method of FIG. 11, identifying (702) a presentation attribute (352) for the structural element (402) includes selecting (814) a presentation attribute (352) from the list (712) in dependence upon a data pattern (812) from the structured document (306). In the method of FIG. 11, identifying (704) a classification identifier (708) is carried out by identifying a classification identifier (708) associated with the presentation attribute (352) on the list (712). In the method of FIG. 11, inserting (706) the classification identifier (708) is carried out by inserting the classification identifier (708) in the structured document (306) according to a structural insertion scope (804) for the selected presentation attribute (352).

Methods of creating presentation documents are further explained with an exemplary use case. Consider the following example of a structured document:

```

<document>
  <page id="1">
    <p id="1">
      a paragraph on an introductory subject
    </p>
  </page>
  <page id="2">
    <p id="2">
      a paragraph on a particular subject
    </p>
    <tech level="2">
      <p id="2">
        a more technical paragraph on the same subject
      </p>
    </tech>
    <security level="2">
      <p id="2">
        a more secret paragraph on the same subject
      </p>
    </security>
    <dept id="marketing">
      <p id="2">
        a paragraph on the same subject with added detail
        regarding marketing
      </p>
    </dept>
    <company id="IBM">
      <p id="2">
        a paragraph on the same subject with added detail
        pertinent to a user's company
      </p>
    </company>
    <p id="3">
      a paragraph on a further subject
    </p>
  </page>

```

-continued

```

... ..
</page>
<page id="3">
... ..
</page>
... ..
</document>

```

This example is discussed with reference to the exemplary system architecture of FIG. 1, assuming that this exemplary structured document is associated in a presentation document with a presentation grammar that includes presentation action identifiers for paragraphs and pages uploaded to a VRS grammar (105) in a voice response server (104). In this example, then, when a presentation session (128) is displaying the first page of the structured document and a user (119) speaks the words "next page," a voice response server (104) parses the speech into a presentation control instruction with a presentation action identifier named "PgDn" and communicates the presentation control instruction through a presentation interface (132) to the presentation session which then displays the next page, in this example, page 2 of the example structured document. Assume that there are five users (119) registered as participants with the presentation session (128), and note that there are five different versions of paragraph 2 on page two of the structured document.

In this example, a first version of paragraph 2 bears a structural identifier `<p></p>` identifying it as a paragraph, but this first version of paragraph 2 bears no classification identifier. In this example, presentation session (128) is programmed to display this unclassified version of paragraph 2 to users having either the lowest technical classifications, the lowest security classifications, or no particular technical or security classifications at all. Moreover, in an example, where there were only one version of paragraph 2, all users would be presented with that one version.

In this example, a second version of paragraph 2 is classified with a classification identifier `<tech level="2">`. In this example, presentation session (128) is programmed to display this second version of paragraph 2 to users having user classification indicating technical level 2. That is, when a user having technical level 2 in the user's profile classifications (210 on FIG. 2) is registered with the presentation session, upon being directed to display paragraph 2, rather than displaying an unclassified version of paragraph 2, the presentation session displays the second version of paragraph 2 classified `<tech level="2">` to such a user.

Similarly, a user having a user profile classification representing a heightened security authorization, security level 2, is shown the version of paragraph 2 classified by the classification identifier `<security level="2">`. A user having a user profile classification identifying the user as a member of the marketing department is shown the version of paragraph 2 classified by the classification identifier `<dept id="marketing">`. A user having a user profile classification identifying the user as an employee of IBM is shown the version of paragraph 2 classified by the classification identifier `<company id="IBM">`.

For purposes of clarity of explanation, the structural elements in this example are shown with only one classification per element. Persons of skill in the art will recognize, however, that it is well within the scope of the present invention

for a structural element of a structured document to be classified with any number of classification identifiers.

Creating a Voice Response Grammar From a Presentation Grammar

5

FIG. 12 sets forth a data flow diagram illustrating a method for creating a voice response grammar in a voice response server including identifying (354) presentation documents (118) for a presentation. In the method of FIG. 4, each presentation document has a presentation grammar (120), and the method includes storing (358) each presentation grammar (120) in a voice response grammar (105) on a voice response server (104). Presentation grammars and voice response grammars may be structured like the full grammars illustrated in FIG. 5 with grammar elements (502-514) for a content type (410). In the exemplary grammar structure of FIG. 5, the content type is taken as a word processing document having structural elements that include pages, paragraphs, bullets, titles, subtitles, and so on, and the data structure includes a column for an identifier (318) of a structural element, a column for a key phrase (516) for formulating a presentation control instruction to invoke a presentation action, and a column for a presentation action identifier (518) representing a presentation action.

In the method of FIG. 12, identifying (354) presentation documents (118) for a presentation includes creating (360) a data structure (128) representing a presentation and listing (362) at least one presentation document (118) in the data structure (128) representing a presentation. A data structure representing a presentation may be implemented as an instance of a presentation session class as shown at reference (128) on FIG. 2. In the method of FIG. 12, listing (362) the at least one presentation document (118) includes storing (366) a location (364) of the presentation document (118) in the data structure (128) representing a presentation. In the exemplary structure of FIG. 2, storing a location of a presentation document may be implemented by storing presentation document locations in the form of URIs in an array of URIs (220). In the method of FIG. 12, storing (358) each presentation grammar (120) includes retrieving (368) a presentation grammar (120) of the presentation document (118) in dependence upon the location (364) of the presentation document (118).

In one exemplary embodiment of the method of FIG. 12, the presentation document (118) is implemented as a file in a file system on a content server (106) and the file has a location (364) identified by a pathname. In such an embodiment, storing (366) a location (364) of the presentation document (118) in the data structure (128) representing a presentation includes storing the pathname and a network location of the content server. An example of storing a pathname and a network location is storing a URI for the document in a URI array such as that illustrated at reference (220) on FIG. 2. Such a URI may have the form:

```

http://www.someContentServer.com/presentationDocuments/myDoc.doc

```

where `www.someContentServer.com` is a domain name for a web server that maps to a network address such as an Internet Protocol address, for example, of a computer where a web server is located. A 'web server' is a server that supports data communications according the HyperText Transport Protocol ('HTTP'). The portion of the URI after the domain name, "presentationDocuments/myDoc.doc," is a pathname for a document on the computer on which the web server is located. In such an embodiment, retrieving (368) a presentation grammar includes retrieving the presentation document

13

from the content server (106) in dependence upon the path-name and extracting the grammar from the presentation document. In an example where the presentation document is located according to a URI as described above and the content server is implemented with a web server, retrieving the presentation document from the content server may be carried out by parsing the URI into an HTTP GET message:

```
GET/presentationDocuments/myDoc.doc HTTP/1.1
```

and transmitting the GET message to the content server at www.ibmContentServer.com.

In this example, the content server returns the presentation document as URI encoded data in an HTTP RESPONSE message. In an example where the returned presentation document has this form:

```
<presentationDocument>
  <presentationGrammar>
    <grammarElement>
      <contentType id="WP">
        <keyPhrase>
          page down
        </keyPhrase>
      <presentationAction id="PgDn">
        <structuralElementIdentifier id="page">
          </grammarElement >
        </presentationGrammar>
      <structuredDocument>
        <page id="1">
          <p id="1"> a paragraph </p>
          <p id="2"> another paragraph </p>
        </page>
        <page id="2"> some text </page>
      </structuredDocument>
    </presentationDocument>
```

extracting the grammar from the presentation document may be carried out by extracting the portion of the presentation document identified by the tags:

```
<presentationGrammar></presentationGrammar>
```

In another exemplary embodiment of the method of FIG. 12, the presentation document (118) is implemented as an instance of an object oriented class on a content server (106). In this example, the presentation document has a presentation document name, and the presentation grammar comprises a member data element of the instance. In such an embodiment, storing (366) a location (364) of the presentation document (118) in the data structure (128) representing a presentation includes storing the presentation document name and a network location of the content server.

An example of storing a pathname and a network location is storing a URI for the document in a URI array such as that illustrated at reference (220) on FIG. 2. Such a URI may have the form:

```
http://www.ibmContentServer.com/servlets/
getPresentationGrammar?presDoc=myDoc.doc
```

where www.someContentServer.com is a domain name for a web server. The portion of the URI after the domain name but before the question mark, "servlets/getPresentationGrammar," is a pathname for server-side functionality for retrieving a presentation document. The server-side functionality could be a CGI (Common Gateway Interface ('CGI') script or other server-side functionality as will occur to those of skill in the art, but in this example the server-side functionality is taken as a Java servlet identified by its name, "getPresentationGrammar." The remainder of the URI is query data encoded as a

14

name-value pair identifying the name of a presentation document, "myDoc.doc," from which a presentation grammar is to be extracted by the servlet.

In such an exemplary embodiment, retrieving (368) a presentation grammar is carried out by requesting the presentation grammar (120) from the content server (106), including communicating the presentation document name as a request parameter; and receiving the presentation grammar (120) in response from the content server (106). In an example where the presentation document is located according to a URI as described above and the content server is implemented with a web server, requesting the presentation grammar (120) from the content server (106), including communicating the presentation document name as a request parameter, may be carried out by parsing the URI into an HTTP GET message:

```
GET /servlets/getPresentationGrammar?
presDoc=myDoc.doc HTTP/1.1
```

and transmitting the GET message to the content server at www.ibmContentServer.com.

In another exemplary embodiment of the method of FIG. 12, the presentation document (118) includes a record in a table in a database on a content server (106). In this example, the presentation document has a presentation document identifier, and the presentation grammar comprises a field in the record. In such an embodiment, storing (366) a location (364) of the presentation document (118) in the data structure (128) representing a presentation includes storing the presentation document identifier and a network location of the content server. In a database table in which each record represents a presentation document, for example, the presentation document identifier may be implemented as a single field unique key such as a serial number for a record, as a presentation document name, or as any functional identifier as will occur to those of skill in the art. In the continuing discussion of this example, the presentation document identifier is taken as a presentation document name.

An example of storing a presentation document identifier and a network location is storing a URI for the document in a URI array such as that illustrated at reference (220) on FIG. 2. Such a URI may have the form:

```
http://www.ibmContentServer.com/cgi-bin/
getPresentationGrammar?presDoc=myDoc.doc
```

where www.someContentServer.com is a domain name for a web server. The portion of the URI after the domain name but before the question mark, "/cgi-bin/getPresentationGrammar," is a pathname for server-side functionality for retrieving a presentation document. The server-side functionality could be a Java servlet or other server-side functionality as will occur to those of skill in the art, but in this example the server-side functionality is taken as a CGI script named "getPresentationGrammar." The remainder of the URI is query data encoded as a name-value pair identifying the name of a presentation document, "myDoc.doc," from which a presentation grammar is to be extracted by the CGI script.

In such an exemplary embodiment, retrieving (368) a presentation grammar is carried out by requesting the presentation grammar (120) from the content server (106), including communicating the presentation document name as a request parameter; and receiving the presentation grammar (120) in response from the content server (106). In an example where the presentation document is located according to a URI as described above and the content server is implemented with a web server, requesting the presentation grammar (120) from the content server (106), including communicating the pre-

sensation document name as a request parameter, may be carried out by parsing the URI into an HTTP GET message:

```
GET          /cgi-bin/getPresentationGrammar?pres
           Doc=myDoc.doc HTTP/1.1
```

and transmitting the GET message to the content server at www.ibmContentServer.com.

Creating a Voice Response Grammar From a User Grammar

FIG. 13 sets forth a data flow diagram illustrating a method for creating a voice response grammar in a voice response server including identifying (372) a user (374) for a presentation where the user has a user grammar (208) and the user grammar includes one or more user grammar elements (378). The method of FIG. 13 also includes storing (376) a multiplicity of user grammar elements (378) for the user in a voice response grammar (105) on a voice response server (104). A user grammar is a data structure that includes a set of key phrases specific to a user that are used to formulate presentation control instructions for invoking presentation actions on presentation servers. For a presentation control instruction that invokes a presentation action instructing a presentation session to ‘page down,’ for example, an individual user may choose to associate with that presentation control instruction the key phrase “rock and roll” or “boogie on down” or any other key phrase favored by a user as will occur to those of skill in the art. Although these particular example are somewhat fanciful, in fact, user grammars serve a useful purpose by providing key phrases for presentation actions that distinguish normal speech. User grammars and voice response grammars may be structured like the full grammars illustrated in FIG. 5 with grammar elements (502-514) for a content type (410).

In the method of FIG. 13, identifying (372) a user for a presentation includes creating (360) a data structure (128) representing a presentation and listing (380) in the data structure (128, 374) at least one user identification (204). A data structure representing a presentation may be implemented as an instance of a presentation session class as shown at reference (128) on FIG. 2. In the method of FIG. 13, listing (380) in the data structure (128, 374) at least one user identification (204) includes creating a list of user names of the users that are registered with the presentation session. That is, a list of users currently participating in the presentation.

In the example of FIG. 13, the user grammar (208) includes a multiplicity of user grammar elements (378) for a content type (370). In this example, each grammar element includes an identifier of a structural element, a key phrase for invoking a presentation action, and an action identifier representing the presentation action, as shown for example in the depiction of an exemplary full grammar at references (318), (518), and (516) on FIG. 5.

The method of FIG. 13 includes identifying (382) presentation documents (118) for the presentation. In this example, each presentation document (118) having a content type (370), and selecting (384) user grammar elements (386) according to the content type (370) of the identified presentation documents (356). In the example of FIG. 13, selecting (384) user grammar elements (386) according to the content type (370) of the identified presentation documents (356) includes comparing the elements of the user grammar with each presentation document in the presentation session and extracting each element of the grammar having the same content type as a presentation document in the presentation

session. In the method of FIG. 13, storing (376) a multiplicity of user grammar elements for the user in a voice response grammar on a voice response server is carried out by storing the selected user grammar elements (386) in the voice response grammar (105).

FIG. 14 is a data flow diagram illustrating an alternative exemplary method for creating a voice response grammar in a voice response server. The method of FIG. 14 includes identifying (388) presentation documents (118) for the presentation. The presentation documents (118) in this example include structured documents (122) having structural element identifiers (322). In the example of FIG. 14, the identified presentation documents are included in a presentation document list (356) in the presentation session.

The user grammar (208) in this example includes a multiplicity of user grammar elements (378), and the method includes selecting (390) user grammar elements (378) in dependence upon the structural element identifiers (322). In this example, selecting (390) user grammar elements (378) in dependence upon the structural element identifiers (322) is carried out by comparing the elements of the user grammar with each structured document of each presentation document in the presentation session and extracting each user grammar element having a structural element identifier for a structural element that occurs in a structured document of a presentation document in the presentation session. In the method of FIG. 14, storing (376) a multiplicity of user grammar elements for the user in a voice response grammar on a voice response server includes storing the selected user grammar elements (386) in the voice response grammar (105).

FIG. 15 is a data flow diagram illustrating another alternative exemplary method for creating a voice response grammar in a voice response server. The method of FIG. 15 includes identifying (394) presentation documents (118) for the presentation. Each presentation document (118) has a presentation grammar (120) including presentation action identifiers (518).

In the example of FIG. 15, the user grammar (208) includes a multiplicity of user grammar elements (378), and the method includes selecting (396) user grammar elements (378) in dependence upon the presentation action identifiers (518). In this example, selecting (396) user grammar elements (378) in dependence upon the presentation action identifiers (518) is carried out by comparing the elements of the user grammar with each presentation grammar of each presentation document of the presentation session and extracting from the user grammar each element having a presentation action identifier that occurs in a presentation grammar of the presentation document. In the method of FIG. 15, storing (376) a multiplicity of user grammar elements for the user in a voice response grammar on a voice response server includes storing the selected user grammar elements (386) in the voice response grammar (105).

Creating a Session Document from a Presentation Document

FIG. 16 sets forth a data flow diagram illustrating an exemplary method for creating a session document (266) from a presentation document (314). A session document is a repository for filtered content, presentation content that is filtered according to attributes of an audience for a presentation, an audience that presents a range of affiliations, technical abilities, security authorizations, and other attributes as will occur to those of skill in the art. The purpose of a session document is to provide a repository for reducing the volume of data for a presentation with respect to unfiltered presentation docu-

ments. A session document is a document derived from a presentation document targeted for the participants of a presentation. More particularly, a session document is a data structure that includes a session grammar derived from a presentation grammar in a presentation document and a session structured document derived from a structured document in a presentation document.

The method of FIG. 16 includes identifying (250) a presentation document (314) for a presentation. The presentation document (314) includes a presentation grammar (312) and a structured document (306) having structural elements (402) classified with classification identifiers (708). Identifying (250) a presentation document (314) typically includes inserting in a list (220) a location for the presentation document (314). The location of a presentation document may be represented by a URI, and a list of locations identifying presentation documents may be implemented as an array of URIs as exemplified by the requested content list (220) in the exemplary presentation session class (128) on FIG. 2.

The method of FIG. 16 includes identifying (252) a user participant (204) for the presentation. In the method of FIG. 16, the user has a user profile (126) that includes user classifications (210) each of which describes some attribute of a user, such as, for example, company affiliation, department membership, technical ability, security authorization level, and so on, for any attribute of a user as may occur to those of skill in the art. Identifying (252) a user (204) typically includes inserting in a list (374) a user identification (204) identifying a user in a presentation participant list (374). In the example of FIG. 16, a user identification is implemented as a user name (204) in a user profile (126).

The method of FIG. 16 includes filtering (254) the structured document (306) in dependence upon the user classifications (210) and the classification identifiers (708). In the method of FIG. 16, filtering (254) the structured document (306) is carried out by extracting (259), from the structured document (306), structural elements (402) having classification identifiers (708) corresponding to the user classifications (210), and writing (260) the extracted structural elements (402) into a session structured document (256) in the session document (266). The method of FIG. 16 also includes filtering (262) the presentation grammar (312), in dependence upon the extracted structural elements (402), into a session grammar (258) in the session document (266). The method of FIG. 16 includes storing (264) the location of the session document (266) in a session document list (222).

For further explanation, consider an example of creating a session document that begins with a presentation document having the following contents:

```
<presentationDocument>
  <presentationGrammar>
    <grammarElement>
      <contentType id="WP">
        <keyPhrase>page down</keyPhrase>
        <presentationAction id="PgDn">
          <structuralElementIdentifier id="page">
        </grammarElement >
    <grammarElement>
      <contentType id="WP">
        <keyPhrase>next bullet</keyPhrase>
        <presentationAction id="NextBullet">
          <structuralElementIdentifier id="bullet">
        </grammarElement >
  </presentationGrammar>
</structuredDocument>
<page id="1">
```

-continued

```
<p id="1">a paragraph on some subject</p>
</page>
<page id="2">
  <p id="2">a paragraph on a particular subject</p>
  <tech level="2">
    <p id="2">a more technical paragraph, same
      subject</p>
  </tech>
  <security level="2">
    <p id="2">a more secret paragraph, same subject</p>
  </security>
  <dept id="marketing">
    <p id="2">a paragraph, same subject, with added
      detail regarding marketing
      <bullet id="1">some bullet text</bullet>
      <bullet id="1">some other bullet text</bullet>
      <bullet id="1">still more bullet text</bullet>
    </p>
  </dept>
  <company id="IBM">
    <p id="2">a paragraph, same subject with added detail
      pertinent to a user's company</p>
  </company>
  <p id="3">a paragraph on some other subject</p>
  ... ..
</page>
</structuredDocument>
</presentationDocument>
```

In this example, an audience of users identified for a presentation include users having in their user profiles user classifications indicating technical level '2' and membership in IBM. None of the registered users have security authorizations and none of them are from the marketing department. Filtering this exemplary presentation document, extracting structural elements with classification identifiers corresponding to the user classifications, writing those structural elements to a session document, and filtering the presentation grammar in dependence upon the extracted structural elements, results in the following exemplary session document:

```
<sessionDocument>
  <sessionGrammar>
    <grammarElement>
      <contentType id="WP">
        <keyPhrase>page down</keyPhrase>
        <presentationAction id="PgDn">
          <structuralElementIdentifier id="page">
        </grammarElement >
  </sessionGrammar>
  <sessionStructuredDocument>
    <page id="1">
      <p id="1"> a paragraph </p>
      <p id="2"> another paragraph </p>
    </page>
    <page id="2">
      <p id="2">a paragraph on a particular subject</p>
      <tech level="2">
        <p id="2">a more technical paragraph, same subject</p>
      </tech>
      <company id="IBM">
        <p id="2">a paragraph, same subject with added detail
          pertinent to a user's company</p>
      </company>
      <p id="3">a paragraph on some other subject</p>
      ... ..
    </page>
  </sessionStructuredDocument>
</sessionDocument>
```

In the resulting session document, the structural element identified as page 2 now excludes versions for security level 2

and for marketing, because none of the users listed for the presentation are in the marketing department or have security authorizations of level 2. In addition, the session grammar excludes a grammar element for bullets because, in the session document above, the only structural element having 5 bullets was the version of paragraph 2 for the marketing department. Excluding the bullets as structural elements in the session structured document means that there is no need to have grammar elements for them in the session grammar. Reducing the number of grammar elements in the session 10 grammar reduces the number of grammar elements in the voice response grammar, thereby increasing the efficiency and accuracy of the voice response server and the overall presentation system.

Amending a Session Document During a Presentation

FIG. 17 sets forth a data flow diagram illustrating an exemplary method for amending a session document (266) during a presentation. The session document (266) includes a session structured document (256), and the method of FIG. 17 includes providing (268) user profiles (126) representing users capable of participating in presentations. In typical 20 embodiments, user profiles for all the users capable of participating in presentations are stored in a database accessible to the presentation session. In the example of FIG. 17, each user profile (126) includes user classifications (210) for a user.

The method of FIG. 17 also includes providing (270) a 30 presentation document (314) that includes a structured document (306) having structural elements (402) classified with classification identifiers (708). In the example of FIG. 17, the locations of the presentation documents from which the session documents for a particular presentation were created are stored in a list such as the requested content list (220) of FIG. 17.

The method of FIG. 17 includes identifying (274) a user 40 profile event (272) for a user during the presentation. A user profile event is an event that results in adding a user classification to the set of user classifications for a presentation. The set of user classifications for a presentation is the set of all user classifications for all users that have been identified as users for a presentation. A user profile event may be represented as a data structure (272) that includes a user identification (205) for a particular user.

A user profile event (272) may be generated by adding a user to the presentation, where the added user has a new user classification for the presentation. That is, one example of a user profile event (272) is adding to a presentation a user whose user classifications include at least one user classification having no corresponding classification identifier in any structural element in the session structured document.

In such an example, at least one of the added user's user 55 classifications is currently not part of any user profile of any of the other users identified for the presentation.

A user profile event (272) also may be generated, for a further example, by changing a user classification (210) in a user profile (126) of a user who is participating in the presentation, where the changed user classification includes a new user classification for the presentation. That is, one example of a user profile event (272) is editing a user's profile during a presentation so that the user's user profile now includes a user classification having no corresponding classification identifier in any structural element in the session structured document. In such an example, the new user classification is

currently not part of any user profile of any of the other users identified for the presentation.

The method of FIG. 17 includes adding (276) to the session structured document (256) at least one structural element (402) from the presentation document (314), the added structural element (402) having a classification identifier (708) that corresponds to a user classification (210) of the user. In the examples just mentioned, regarding adding a new user to a presentation or a new user classification to a profile, adding (276) to the session structured document (256) a structural 10 element (402) from the presentation document (314), the added structural element (402) having a classification identifier (708) that corresponds to a user classification (210) of the user, means that the new structural element is one that no other user identified for the presentation was entitled to view. Because adding a structural element may mean adding a structural element of a kind not otherwise represented in the session structured document, the method of FIG. 17 advantageously also includes adding (278) a grammar element 20 (316) to the session grammar (258) in dependence upon the added structural element (402).

For further explanation, consider the following example of amending a session document (266) during a presentation. In this example, a session document is used for a presentation 25 having users whose user profiles include user classifications of technical level '2' and membership in IBM:

```

30 <sessionDocument>
  <sessionGrammar>
    <grammarElement>
      <contentType id="WP">
        <keyPhrase>page down</keyPhrase>
        <presentationAction id="PgDn">
          <structuralElementIdentifier id="page">
35          </grammarElement >
    </sessionGrammar>
    <sessionStructuredDocument>
      <page id="1">
        <p id="1"> a paragraph </p>
        <p id="2"> another paragraph </p>
40      </page>
      <page id="2">
        <p id="2">a paragraph on a particular subject</p>
        <tech level="2">
          <p id="2">a more technical paragraph, same subject</p>
45        </tech>
        <company id="IBM">
          <p id="2">a paragraph, same subject with added detail
            pertinent to a user's company</p>
        </company>
        <p id="3">a paragraph on some other subject</p>
50      </page>
    </sessionStructuredDocument>
  </sessionDocument>

```

This session document in this example was created from the following presentation document:

```

60 <presentationDocument>
  <presentationGrammar>
    <grammarElement>
      <contentType id="WP">
        <keyPhrase>page down</keyPhrase>
        <presentationAction id="PgDn">
          <structuralElementIdentifier id="page">
65      </grammarElement >
    <grammarElement>
      <contentType id="WP">

```

-continued

```

    <keyPhrase>next bullet</keyPhrase>
    <presentationAction id="NextBullet">
    <structuralElementIdentifier id="bullet">
  </grammarElement >
</presentationGrammar>
<structuredDocument>
  <page id="1">
    <p id="1">a paragraph on some subject</p>
  </page>
  <page id="2">
    <p id="2">a paragraph on a particular subject</p>
    <tech level="2">
    <p id="2">a more technical paragraph, same
    subject</p>
    </tech>
    <security level="2">
    <p id="2">a more secret paragraph, same subject</p>
    </security>
    <dept id="marketing">
    <p id="2">a paragraph, same subject, with added
    detail regarding marketing
      <bullet id="1">some bullet text</bullet>
      <bullet id="1">some other bullet text</bullet>
      <bullet id="1">still more bullet text</bullet>
    </p>
    </dept>
    <company id="IBM">
    <p id="2">a paragraph, same subject with added detail
    pertinent to a user's company</p>
    </company>
    <p id="3">a paragraph on some other subject</p>
    ... ..
  </page>
</structuredDocument>
</presentationDocument>

```

The session document in this example contains no structural elements classified for users from the marketing department. After beginning the presentation a user from the marketing department joins the presentation. The user's joining the presentation is represented by adding the user's user identification to a list of users identified for the presentation. Adding the user ID to the list identifies (274) a user profile event (272) which is represented by a data structure that includes the user's user identification (205). Amending the session document proceeds by adding (276) to a session structured document (256) one or more structural elements (402) from a structured document in the presentation document from which the session structured document was created. Adding (276) to the session structured document (256) at least one structural element (402) from the presentation document (314) is carried out by adding a structural element (402) having a classification identifier (708) that corresponds to a user classification (210) of the user. User classifications of the user are read from the user profiles (126) using the user identification (205) provided to the adding process (276) by the user profile event (272). In this example, adding a structural element to the session structured documents is carried out by adding the following paragraph from the structured document of the presentation document set forth above:

```

<dept id="marketing">
<p id="2">a paragraph, same subject, with added detail regarding
marketing
  <bullet id="1">some bullet text</bullet>
  <bullet id="1">some other bullet text</bullet>
  <bullet id="1">still more bullet text</bullet>
</p>
</dept>,

```

thereby creating the following amended session document:

```

<sessionDocument>
  <sessionGrammar>
    <grammarElement>
      <contentType id="WP">
      <keyPhrase>page down</keyPhrase>
      <presentationAction id="PgDn">
      <structuralElementIdentifier id="page">
    </grammarElement >
  </sessionGrammar>
  <sessionStructuredDocument>
    <page id="1">
      <p id="1"> a paragraph </p>
      <p id="2"> another paragraph </p>
    </page>
    <page id="2">
      <p id="2">a paragraph on a particular subject</p>
      <tech level="2">
      <p id="2">a more technical paragraph, same subject</p>
      </tech>
      <company id="IBM">
      <p id="2">a paragraph, same subject with added detail
      pertinent to a user's company</p>
      </company>
      <dept id="marketing">
      <p id="2">a paragraph, same subject, with added detail
      regarding marketing
        <bullet id="1">some bullet text</bullet>
        <bullet id="1">some other bullet text</bullet>
        <bullet id="1">still more bullet text</bullet>
      </p>
      </dept>
      <p id="3">a paragraph on some other subject</p>
      ... ..
    </page>
  </sessionStructuredDocument>
</sessionDocument>

```

Amending the session document also includes adding to the session grammar of the session document a new grammar element from the presentation grammar. There were no bullets in the session structured document before the exemplary user profile event and therefore no grammar elements supporting presentation control instructions for bullets. Adding the marketing paragraph also added bullets, so the method advantageously includes adding grammar elements supporting presentation control instructions for bullets:

```

<grammarElement>
  <contentType id="WP">
  <keyPhrase>next bullet</keyPhrase>
  <presentationAction id="NextBullet">
  <structuralElementIdentifier id="bullet">
</grammarElement >,

```

thereby creating the following amended session document:

```

<sessionDocument>
  <sessionGrammar>
    <grammarElement>
      <contentType id="WP">
      <keyPhrase>page down</keyPhrase>
      <presentationAction id="PgDn">
      <structuralElementIdentifier id="page">
    </grammarElement >
    <grammarElement>
      <contentType id="WP">
      <keyPhrase>next bullet</keyPhrase>
      <presentationAction id="NextBullet">

```

-continued

```

    <structuralElementIdentifier id="bullet">
  </grammarElement >
</sessionGrammar>
<sessionStructuredDocument>
  <page id="1">
    <p id="1"> a paragraph </p>
    <p id="2"> another paragraph </p>
  </page>
  <page id="2">
    <p id="2">a paragraph on a particular subject</p>
    <tech level="2">
    <p id="2">a more technical paragraph, same subject</p>
    </tech>
    <company id="IBM">
    <p id="2">a paragraph, same subject with added detail
      pertinent to a user's company</p>
    </company>
    <dept id="marketing">
    <p id="2">a paragraph, same subject, with added detail
      regarding marketing
      <bullet id="1">some bullet text</bullet>
      <bullet id="1">some other bullet text</bullet>
      <bullet id="1">still more bullet text</bullet>
    </p>
    </dept>
    <p id="3">a paragraph on some other subject</p>
    ... ..
  </page>
</sessionStructuredDocument>
</sessionDocument>

```

Differential Dynamic Content Delivery with Device Controlling Action

FIG. 18 sets forth a data flow diagram illustrating an exemplary method for differential dynamic content delivery. Differential dynamic content delivery is delivery of the content of a presentation to user participants according to a wide variety of participant interest, company, group, or department membership, technical knowledge, security authorization, and so on, across almost any dimension in which participants may vary. Differential dynamic content delivery is accomplished generally in methods and systems according to embodiments of the present invention by use of structured, classified documents, presentation documents and session documents, each of which includes a grammar and a structured document as described below. Using such documents as a source of presentation content, differential dynamic content delivery is accomplished then by selecting from a structured document classified structural elements for delivery to particular user participants according to the classification identifiers in the document and user classifications from user profiles.

FIG. 18 sets forth a data flow diagram illustrating an exemplary method for differential dynamic content delivery that includes providing (450) a session document (266) for a presentation. In the method of FIG. 18, the session document (266) includes a session grammar (258) and a session structured document (256), and providing (450) a session document (266) for a presentation is carried out by creating a session document from a presentation document as described in detail above in the discussion regarding FIG. 16.

The method of FIG. 18 also includes creating (462) a presentation control instruction (460). A presentation control instruction is an instruction to a presentation server (102) to carry out a particular presentation action such as, for example, 'display next page,' 'display next slide,' 'display paragraph 5,' and so on. More particularly, in differential dynamic content delivery, presentation actions are carried out by presenting to

a particular user a version of a particular structural element, such as a paragraph or a slide, according to user classifications such as company name, department name, security authorization, and so on. In the method of FIG. 18, an exemplary presentation control instruction (460) includes a presentation action identifier (518) and one or more optional parameters (520).

In the method of FIG. 18, creating the presentation control instruction is carried out by receiving (464) from a user (119) participating in the presentation a key phrase (516) and optional parameters (520) for invoking a presentation action and parsing (466) the key phrase (516) and parameters (520) against a voice response grammar (105) into a presentation control instruction (460). In this example, receiving (464) a key phrase (516) is carried out by use of a Voice Over Internet Protocol ("VOIP") link (130) that carries the speech of at least one user (119) from the user's client device to a voice response server (104). A VOIP link is a kind of computer hardware and software that uses an internet protocol network instead of a traditional telephone network as the transmission medium for speech. VOIP is sometimes referred to as 'IP telephony' or 'Voice Over the Internet' ("VOI"). Examples of user client devices include any computer equipment capable of converting input speech to digital data and transmitting it over the internet protocol to a voice response server, including handheld wireless devices, personal digital assistants, personal computers, laptop computers, and the like.

The method of FIG. 18 also includes receiving (458) a presentation control instruction (460) in a presentation server and selecting (452) from a session structured document (256) a classified structural element (402) in dependence upon user classifications (210) of a user participant (119) in the presentation. In the method of FIG. 18, selecting (452) a classified structural element (402) is carried out by selecting a classified structural element (402) in dependence upon the presentation action identifier (518) and the parameters (520) from the presentation control instruction (460). In the method of FIG. 18, selecting (452) a classified structural element (402) also includes selecting a classified structural element having an associated classification identifier (708) that corresponds to the user classification (210).

For further explanation, consider an example using the following exemplary session document:

```

<sessionDocument>
  <sessionGrammar>
    <grammarElement>
      <contentType id="WP">
        <keyPhrase>page down</keyPhrase>
        <presentationAction id="PgDn">
          <structuralElementIdentifier id="page">
        </grammarElement >
    </sessionGrammar>
  <sessionStructuredDocument>
    <page id="1">
      <p id="1"> a paragraph </p>
      <p id="2"> another paragraph </p>
    </page>
    <page id="2">
      <p id="2">a paragraph on a particular subject</p>
      <tech level="2">
      <p id="2">a more technical paragraph, same
        subject</p>
      </tech>
      <company id="IBM">
      <p id="2">a paragraph, same subject with added detail
        pertinent to a user's company</p>
      </company>
      <p id="3">a paragraph on some other subject</p>

```

-continued

```

... ..
</page>
</sessionStructuredDocument>
</sessionDocument>

```

In this example, assume that a first user participant has in a user profile user classifications indicating that the user is an IBM employee and a second user has user classifications indicating that the user has technical ability level '2'. In this example, a presentation server having the above session document installed upon it receives (458) a presentation control instruction (460) to move to the display to the second page of the session structured document. The presentation server then selects (452) from the session structured document (256) for the first user the structural element identified as a version of page two and classified as:

```

<company id="IBM">
<p id="2">a paragraph, same subject with added detail
pertinent to a user's company</p>
</company>

```

and for the second user the structural element identified as a version of page two and classified as:

```

<tech level="2">
<p id="2">a more technical paragraph, same subject</p>
</tech>

```

The method of FIG. 18 also includes presenting (454) the selected structural element (456) to the user (119). In the method of FIG. 18, presenting (454) the selected structural element (456) to the user may be carried out, for example, by selecting a data communications protocol for the presentation, inserting the selected structural element (without its classification identifiers) in a data structure appropriate to the data communications protocol, and transmitting the data structure to the user according to the data communications protocol. If, for example, the data communications protocol is selected as HTTP, a data structure appropriate to the data communications protocol is an HTML document in an HTTP RESPONSE message. In such an example, presenting (454) the selected structural element (456) to the user may be carried out, for the two exemplary versions of page two selected above, by the following HTTP RESPONSE messages:

```

HTTP/1.1 200 OK
Date: _____
Content-Type: text/xml
Content-Length: 128
<html><body><p id="2">a paragraph, same subject with added detail
pertinent to a user's company</p> </body></html>

```

and for the second user the structural element identified as a version of page two and classified as:

```

HTTP/1.1 200 OK
Date: _____
Content-Type: text/xml

```

-continued

```

Content-Length: 103
<html><body><p id="2">a more technical paragraph, same
subject</p></body></html>

```

respectively, the first sent to the client device of the first user and the second sent to the client device of the second user. Note that in both transmission, the classification identifiers are omitted, <company id="IBM"> and <tech level="2"> respectively.

This example of presenting (454) a selected structural element (456) to a user (119) is expressed in terms of HTML and HTTP, a stateless, asynchronous protocol. Many embodiments will statefully hold open a data communications connection, such as a TCP/IP connection, between a presentation server and a user client device. A Stateful Java Enterprise Session Bean™ may be used, for example, to hold open a TCP/IP connection implemented with a Java socket object. Readers of skill in the art will recognize therefore that HTML and HTTP are used for explanation, not for limitation. In fact, any presentation application using any appropriate data communications protocol useful for multi-media presentations may be used to present structural elements to users according to embodiments of the present invention. Such application may be obtained off-the-shelf commercially or they may be specially developed for particular presentations or kinds of presentation. An example of such an application available commercially is Microsoft NetMeeting™. Examples of other data communications protocols useful with various embodiments of the present invention include the Session Initiation Protocol specified in the IETF's RFC 2543, the Real Time Streaming Protocol as specified in the IETF's RFC 2326, the Real Time Transport Protocol of RFC 1889, and the World Wide Web Consortium's VoiceXML protocol specified in the 2003 document entitled "Voice Extensible Markup Language (VoiceXML) Version 2.0".

The method of FIG. 18 also includes identifying a device controlling action. A device controlling action is an action to be taken on a device in a user's computing environment. In typical user computing environment includes a user client device that may be represented by a computer workstation connected to a local area network to which are connected many other client devices useful to support a presentation. Audio may be directed by a device controlling action across the LAN to an audio amplifier outside the user's computer workstation. Video elements may be directed by a device controlling action to a television monitor that is separate from the user's computer workstation but connected to it through the LAN. Lighting may be connected and controlled through device controlling actions which may advantageously enhance the presentation by representing changes in tenor or mood.

In the method of FIG. 18, identifying a device controlling action may be carried out by identifying a device controlling action in dependence upon a presentation control instruction. In such embodiments, a presentation server (102) is programmed to identify a device controlling action in dependence upon presentation control instructions (460). In some such embodiments, identifying a device controlling action may be carried out by identifying a device controlling action in dependence upon a spoken key word, parsing the spoken keyword into a presentation control instruction in a voice response server (104), and sending the presentation control instruction (460) to a presentation server (102).

In the method of FIG. 18, identifying a device controlling action may be carried out by identifying a device controlling action in dependence upon a classified structural element. In such embodiments, classified structural elements have associated device controlling actions. When such a classified structural element is selected for presentation to a user, the associated device controlling action is identified from its association with a structural element. For further explanation, consider an example using the following exemplary session document:

```

<sessionDocument>
  <sessionGrammar>
    <grammarElement>
      <contentType id="WP">
        <keyPhrase>page down</keyPhrase>
        <presentationAction id="PgDn">
          <structuralElementIdentifier id="page">
        </grammarElement >
    </sessionGrammar>
  <sessionStructuredDocument>
    <page id="1">
      <deviceControllingAction deviceID= "userStereo"
        actionID = "setVolumeToHigh />
      <p id="1"> a paragraph </p>
      <p id="2"> another paragraph </p>
    </page>
    <page id="2">
      <deviceControllingAction deviceID= "userStereo"
        actionID = "setVolumeToNormal />
      <p id="2">a paragraph on a particular subject</p>
      <tech level="2">
        <p id="2">a more technical paragraph, same
          subject</p>
      </tech>
      <company id="IBM">
        <p id="2">a paragraph, same subject with added detail
          pertinent to a user's company</p>
      </company>
      <p id="3">a paragraph on some other subject</p>
      ... ..
    </page>
  </sessionStructuredDocument>
</sessionDocument>

```

This exemplary session document contains a structural element, a page identified as <page id="1"> that in turn contains an identification of a device controlling represented as

```

<deviceControllingAction deviceID= "userStereo"
  actionID = "setVolumeToHigh />,

```

ordering control of a stereo system connected on a LAN to a user's computer workstation to turn its volume to high for the duration of page 1. Similarly, the structural element identified as page 2 in the same session document contains an identification of a device controlling action represented as

```

<deviceControllingAction deviceID= "userStereo"
  actionID = "setVolumeToNormal />,

```

ordering control of the stereo system to return its volume to normal when page 2 is displayed.

In the method of FIG. 18, identifying (468) a device controlling action (470) may be carried out by identifying a

device controlling action in dependence upon a classification identifier. In such embodiments, a classification identifier (708) embedded in a session structured document (256) of a session document (266) may have an associated device controlling action. When such a classification identifier implicated selecting a particular structural element for presentation to a user whose user classification corresponds to the classification identifier, the associated device controlling action is identified by its association with a classification identifier. For further explanation, consider an example using the following exemplary session document:

```

<sessionDocument>
  <sessionGrammar>
    <grammarElement>
      <contentType id="WP">
        <keyPhrase>page down</keyPhrase>
        <presentationAction id="PgDn">
          <structuralElementIdentifier id="page">
        </grammarElement >
    </sessionGrammar>
  <sessionStructuredDocument>
    <page id="1">
      <p id="1"> a paragraph </p>
      <p id="2"> another paragraph </p>
    </page>
    <page id="2">
      <p id="2">a paragraph on a particular subject</p>
      <tech level="2">
        <p id="2">a more technical paragraph, same
          subject</p>
      </tech>
      <company id="IBM">
        <deviceControllingAction deviceID=
          "userStereo" actionID="setVolumeToHigh />
        <p id="2">a paragraph, same subject with
          added detail pertinent to a user's
          company</p>
        <deviceControllingAction deviceID=
          "userStereo" actionID="setVolumeToNormal />
      </company>
      <p id="3">a paragraph on some other subject</p>
      ... ..
    </page>
  </sessionStructuredDocument>
</sessionDocument>

```

This exemplary session document contains a classification identifier <company id="IBM"> that classifies a version of a structural element identified as paragraph 2 of page 2. The classification identifier in turn contains an identification of a device controlling action:

```

<deviceControllingAction deviceID= "userStereo"
  actionID = "setVolumeToHigh />,

```

ordering control of a stereo system connected on a LAN to a user's computer workstation to turn its volume to high for the duration of paragraph 2. Similarly, the <company> classification identifier for paragraph 2 contains an additional identification of a device controlling action represented as:

```

<deviceControllingAction deviceID= "userStereo"
  actionID = "setVolumeToNormal />,

```

representing an order to return the volume to normal after paragraph 2 is displayed.

The method of FIG. 18 also includes executing (472) the device controlling action to control a device for the user. In the method of FIG. 18, executing (472) the device controlling action to control a device for the user may be carried out by calling a member method in an OSGi-compliant bundle operating in an OSGi framework on a services gateway (476). Calling a member method in an OSGi-compliant bundle operating in an OSGi framework on a services gateway (476) is further explained with reference to FIG. 19.

FIG. 19 is a block diagram of an exemplary services gateway (476) useful in executing device controlling actions according to the present invention. The services gateway (476) of FIG. 19 is, in some exemplary architectures useful in embodiments of the present invention, an OSGi compatible services gateway (476). While exemplary embodiments of methods for differential dynamic content delivery are described in this specification using OSGi, many other applications and frameworks other than OSGi will work to implement methods of differential dynamic content delivery according to the present invention and are therefore well within the scope of the present invention. Commercial implementations of OSGi, such as JES and SMF, are also useful in implementing methods of the present invention.

OSGi Stands for 'Open Services Gateway Initiative.' The OSGi specification is a Java-based application layer framework that provides vendor neutral application and device layer APIs and functions for various devices using arbitrary communication protocols operating in networks in homes, cars, and other environments. OSGi works with a variety of networking technologies like Ethernet, Bluetooth, the 'Home, Audio and Video Interoperability standard' (HAVi), IEEE 1394, Universal Serial Bus (USB), WAP, X-10, Lon Works, HomePlug and various other networking technologies. The OSGi specification is available for free download from the OSGi website at www.osgi.org.

The services gateway (476) of FIG. 19 includes a service framework (131). In many example embodiments the service framework is an OSGi service framework (131). An OSGi service framework (131) is written in Java and therefore, typically runs on a Java Virtual Machine (JVM) (117). In OSGi, the service framework (131) of FIG. 1 is a hosting platform for running 'services' (119). The term 'service' or 'services' in this disclosure, depending on context, generally refers to OSGi-compliant services.

Services (119) are the main building blocks for creating applications according to the OSGi. A service (119) is a group of Java classes and interfaces that implement a certain feature. The OSGi specification provides a number of standard services. For example, OSGi provides a standard HTTP service that creates a web server that can respond to requests from HTTP clients. OSGi also provides a set of standard services called the Device Access Specification. For example, the Device Access Specification ("DAS") provides services to identify a client device (478) connected to the services gateway, search for a driver for that device, and install the driver for the device.

In typical embodiments of methods of differential dynamic content delivery a device controlling actions are implemented as a set of services (119) packaged in 'OSGi bundles' (121) with other files, images, and resources that the services (119) need to carry out the device controlling action. An OSGi bundle (121) is a Java archive or 'JAR' file including one or more service implementations (119), an activator class (127), and a manifest file (125). An activator class (127) is a Java class that the service framework (131) uses to start and stop a bundle. A manifest file (125) is a standard text file that describes the contents of the bundle (121).

The services framework (131) in OSGi also includes a service registry (128). The service registry (128) includes a service registration (129) including the service's name and an instance of a class that implements the service for each bundle (121) installed on the framework (131) and registered with the service registry (128). A device controlling action implemented as an OSGi bundle (121) may request services that are not included in the bundle (121), but are registered on the framework service registry (128). To find a service, a bundle (121) performs a query on the framework's service registry (128).

It will be understood from the foregoing description that modifications and changes may be made in various embodiments of the present invention without departing from its true spirit. The descriptions in this specification are for purposes of illustration only and are not to be construed in a limiting sense. The scope of the present invention is limited only by the language of the following claims.

What is claimed is:

1. A system for differential dynamic content delivery, the system comprising:
 - means for creating a session document from a presentation document, including:
 - means for identifying a presentation document for a presentation, the presentation document including a presentation grammar and a structured document having structural elements classified with classification identifiers;
 - means for identifying a user participant for the presentation, the user having a user profile comprising user classifications; and
 - means for filtering the structured document in dependence upon the user classifications and the classification identifiers, including, means for extracting, from the structured document, structural elements having classification identifiers corresponding to the user classifications, and
 - means for writing the extracted structural elements into a session structured document in the session document;
 - means for providing a session document for a presentation, wherein the session document includes a session grammar and a session structured document;
 - means for selecting from the session structured document a classified structural element in dependence upon user classifications of a user participant in the presentation;
 - means for presenting the selected structural element to the user, including:
 - means for selecting a data communications protocol for the presentation;
 - means for inserting the selected structural element in a data structure appropriate to the data communications protocol; and
 - means for transmitting the data structure to the user according to the data communications protocol;
 - means for identifying a device controlling action in dependence upon a presentation control instruction, a spoken key word, a classified structural element, and a classification identifier; and
 - means for executing the device controlling action to control a device for the user, further comprises means for calling a member system in an OSGi-compliant bundle operating in an OSGi framework on a services gateway.
2. The system of claim 1 further comprising means for receiving a presentation control instruction, wherein:
 - the presentation control instruction includes a presentation action identifier and one or more optional parameters; and

31

means for selecting a classified structural element includes means for selecting a classified structural element in dependence upon the presentation action identifier and the parameters.

3. The system of claim 2 further comprising means for creating the presentation control instruction, including:

means for receiving from a user participating in the presentation a key phrase and optional parameters for invoking a presentation action; and

means for parsing the key phrase and parameters against a voice response grammar into a presentation control instruction.

4. The system of claim 1 wherein means for selecting a classified structural element further comprises means for selecting a classified structural element having an associated classification identifier that corresponds to the user classification.

5. The system of claim 1 further comprising means for filtering the presentation grammar, in dependence upon the extracted structural elements, into a session grammar in the session document.

6. The system of claim 1 further comprising means for creating a presentation document, including:

means for creating, in dependence upon an original document, a structured document comprising one or more structural elements;

means for classifying a structural element of the structured document according to a presentation attribute; and

means for creating a presentation grammar for the structured document, wherein the presentation grammar for the structured document includes grammar elements each of which includes an identifier for at least one structural element of the structured document.

7. A computer program product for differential dynamic content delivery, the computer program product comprising: a recording medium;

means, recorded on the recording medium, for creating a session document from a presentation document, including:

means, recorded on the recording medium, for identifying a presentation document for a presentation, the presentation document including a presentation grammar and a structured document having structural elements classified with classification identifiers;

means, recorded on the recording medium, for identifying a user participant for the presentation, the user having a user profile comprising user classifications; and

means, recorded on the recording medium, for filtering the structured document in dependence upon the user classifications and the classification identifiers, including, means, recorded on the recording medium, for extracting, from the structured document, structural elements having classification identifiers corresponding to the user classifications, and means, recorded on the recording medium, for writing the extracted structural elements into a session structured document in the session document;

means, recorded on the recording medium, for providing a session document for a presentation, wherein the session document includes a session grammar and a session structured document;

means, recorded on the recording medium, for selecting from the session structured document a classified structural element in dependence upon user classifications of a user participant in the presentation;

means, recorded on the recording medium, for presenting the selected structural element to the user, including:

32

means, recorded on the recording medium, for selecting a data communications protocol for the presentation;

means, recorded on the recording medium, for inserting the selected structural element in a data structure appropriate to the data communications protocol; and

means, recorded on the recording medium, for transmitting the data structure to the user according to the data communications protocol;

means, recorded on the recording medium, for identifying a device controlling action in dependence upon a presentation control instruction, a spoken key word, a classified structural element, and a classification identifier; and

means, recorded on the recording medium, for executing the device controlling action to control a device for the user, further comprises means, recorded on the recording medium, for calling a member computer program product in an OSGi-compliant bundle operating in an OSGi framework on a services gateway.

8. The computer program product of claim 7 further comprising means, recorded on the recording medium, for receiving a presentation control instruction, wherein:

the presentation control instruction includes a presentation action identifier and one or more optional parameters; and

means, recorded on the recording medium, for selecting a classified structural element includes means, recorded on the recording medium, for selecting a classified structural element in dependence upon the presentation action identifier and the parameters.

9. The computer program product of claim 8 further comprising means, recorded on the recording medium, for creating the presentation control instruction, including:

means, recorded on the recording medium, for receiving from a user participating in the presentation a key phrase and optional parameters for invoking a presentation action; and

means, recorded on the recording medium, for parsing the key phrase and parameters against a voice response grammar into a presentation control instruction.

10. The computer program product of claim 7 wherein means, recorded on the recording medium, for selecting a classified structural element further comprises means, recorded on the recording medium, for selecting a classified structural element having an associated classification identifier that corresponds to the user classification.

11. The computer program product of claim 7 further comprising means, recorded on the recording medium, for filtering the presentation grammar, in dependence upon the extracted structural elements, into a session grammar in the session document.

12. The computer program product of claim 7 further comprising means, recorded on the recording medium, for creating a presentation document, including:

means, recorded on the recording medium, for creating, in dependence upon an original document, a structured document comprising one or more structural elements;

means, recorded on the recording medium, for classifying a structural element of the structured document according to a presentation attribute; and

means, recorded on the recording medium, for creating a presentation grammar for the structured document, wherein the presentation grammar for the structured document includes grammar elements each of which includes an identifier for at least one structural element of the structured document.