



US007753881B2

(12) **United States Patent**
Fournie et al.

(10) **Patent No.:** **US 7,753,881 B2**
(45) **Date of Patent:** ***Jul. 13, 2010**

(54) **ADMINISTRATION FEEDING SET**

(75) Inventors: **Glenn G. Fournie**, Smithton, IL (US);
James Harr, Foristell, MO (US); **Kevin C. Meier**, Affton, MO (US); **Ricky A. Sisk**, Washington, MO (US)

(73) Assignee: **Covidien AG** (CH)

(*) Notice: Subject to any disclaimer, the term of this patent is extended or adjusted under 35 U.S.C. 154(b) by 245 days.

This patent is subject to a terminal disclaimer.

(21) Appl. No.: **11/678,350**

(22) Filed: **Feb. 23, 2007**

(65) **Prior Publication Data**

US 2007/0135766 A1 Jun. 14, 2007

Related U.S. Application Data

(62) Division of application No. 10/853,958, filed on May 25, 2004, now Pat. No. 7,462,170.

(51) **Int. Cl.**
A61M 37/00 (2006.01)

(52) **U.S. Cl.** **604/131**; 604/151

(58) **Field of Classification Search** 604/131,
604/151-155, 65-67; 417/477.2
See application file for complete search history.

(56) **References Cited**

U.S. PATENT DOCUMENTS

3,626,938 A	12/1971	Versaci
3,896,803 A	7/1975	Mason
3,985,133 A	10/1976	Jenkins
4,396,385 A	8/1983	Kelly
4,460,355 A	7/1984	Layman
4,519,792 A	5/1985	Dawe
4,557,725 A	12/1985	Heyne

4,604,093 A	8/1986	Brown
4,605,396 A	8/1986	Tseo
4,685,910 A	8/1987	Schweizer
D293,129 S	12/1987	Millerd
4,710,166 A	12/1987	Thompson

(Continued)

FOREIGN PATENT DOCUMENTS

EP 0398583 A2 11/1990

(Continued)

OTHER PUBLICATIONS

USPTO Office action issued in U.S. Appl. No. 10/853,958 dated Jun. 14, 2007, 7 pages.

(Continued)

Primary Examiner—Nicholas D Lucchesi
Assistant Examiner—Theodore J Stigell
(74) *Attorney, Agent, or Firm*—Edward S. Jarmolowicz, Esq.

(57) **ABSTRACT**

An administration feeding set for use with a flow control apparatus to deliver fluid from at least one fluid source to a patient. The set includes tubing for flow of fluid along a fluid pathway and a mounting member on the tubing adapted to engage the flow control apparatus. The mounting member has at least two receiving portions co-axial with the fluid pathway. The set also includes one or more identification members selectively positioned on one or more of the at least two receiving portions of the mounting member to permit identification of the administration feeding set as having a particular functional configuration different from another functional configuration.

13 Claims, 13 Drawing Sheets

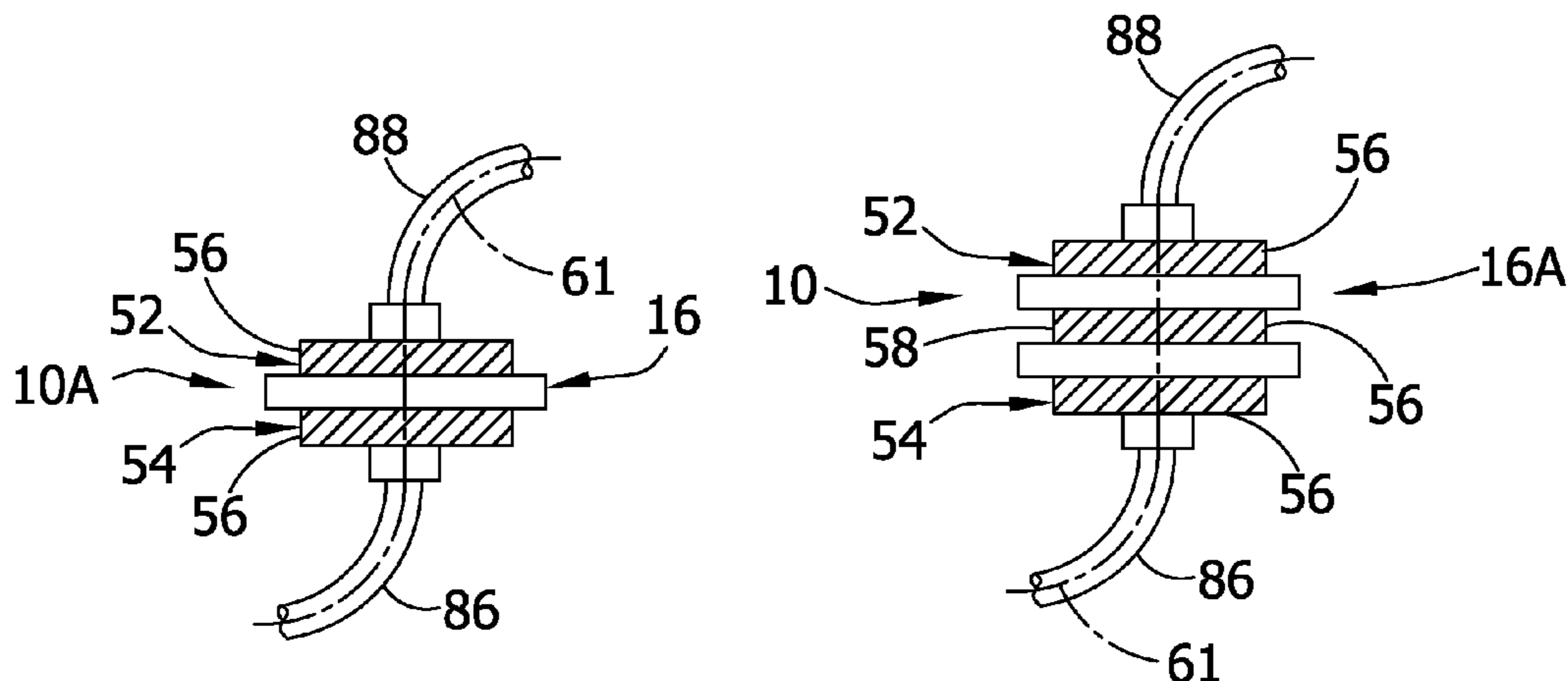

U.S. PATENT DOCUMENTS

4,714,463 A 12/1987 Archibald
 4,741,736 A 5/1988 Brown
 4,789,000 A 12/1988 Asianian
 4,798,590 A 1/1989 O'Leary
 4,820,268 A 4/1989 Kawamura
 4,831,866 A 5/1989 Forkert
 4,838,856 A 6/1989 Mulreany
 4,840,542 A 6/1989 Abbott
 4,845,487 A 7/1989 Frantz
 4,850,805 A 7/1989 Madsen
 4,850,980 A 7/1989 Lentz et al.
 4,884,103 A 11/1989 Yamada
 4,898,581 A 2/1990 Iwatschenko
 4,913,703 A * 4/1990 Pasqualucci et al. 604/153
 4,915,688 A 4/1990 Bischof
 4,918,973 A 4/1990 Kruse
 4,919,596 A 4/1990 Slate et al.
 4,950,254 A 8/1990 Andersen
 4,955,860 A 9/1990 Ruano
 5,057,081 A 10/1991 Sunderland
 5,111,683 A 5/1992 Fond
 5,147,313 A 9/1992 Dikeman
 5,158,437 A 10/1992 Natwick et al.
 5,171,029 A 12/1992 Maxwell
 5,181,910 A 1/1993 Scanlon
 5,197,322 A 3/1993 Indravudh
 5,201,711 A 4/1993 Pasqualucci
 5,213,483 A 5/1993 Flaherty
 5,253,640 A 10/1993 Falb et al.
 5,272,917 A 12/1993 Pippert
 5,299,446 A 4/1994 Pardinias et al.
 5,318,413 A 6/1994 Bertoncini
 5,364,364 A 11/1994 Kasvikis
 5,368,562 A 11/1994 Blomquist et al.
 5,374,248 A 12/1994 Lopez
 5,374,251 A 12/1994 Smith
 5,415,641 A 5/1995 Yerlikaya
 5,431,627 A 7/1995 Pastrone
 5,437,642 A 8/1995 Thill
 5,443,453 A 8/1995 Walker
 5,499,968 A 3/1996 Milijasevic
 5,531,680 A 7/1996 Dumas et al.
 5,531,697 A 7/1996 Olsen
 5,562,615 A 10/1996 Nassif
 5,569,026 A * 10/1996 Novak 417/477.1
 5,584,671 A 12/1996 Schweitzer
 5,603,353 A 2/1997 Clark
 5,634,907 A 6/1997 Rani
 5,681,294 A 10/1997 Osborne
 5,704,584 A 1/1998 Winterer

5,755,683 A 5/1998 Houle
 5,772,637 A 6/1998 Heinzmann
 5,807,321 A 9/1998 Stoker
 5,807,333 A 9/1998 Osborne
 5,814,015 A 9/1998 Gargano
 5,840,058 A 11/1998 Ammann et al.
 5,951,510 A 9/1999 Barak
 6,042,564 A 3/2000 Barak
 6,059,544 A 5/2000 Jung
 6,139,748 A 10/2000 Ericson et al.
 6,142,979 A 11/2000 McNally
 6,164,921 A 12/2000 Moubayed
 6,250,130 B1 6/2001 Howard et al.
 6,280,440 B1 8/2001 Gocho
 6,283,719 B1 9/2001 Frantz et al.
 6,364,857 B1 4/2002 Gray
 6,368,314 B1 4/2002 Kipfer
 6,422,057 B1 7/2002 Anderson
 6,491,659 B1 12/2002 Miyamoto
 6,626,862 B1 9/2003 Duchon et al.
 6,641,562 B1 11/2003 Peterson
 6,985,870 B2 1/2006 Martucci et al.
 7,092,797 B2 8/2006 Gaines
 2001/0031944 A1 10/2001 Peterson et al.
 2002/0120186 A1 8/2002 Keimel
 2002/0138034 A1 9/2002 Derek
 2002/0151838 A1 10/2002 Beck
 2002/0169424 A1 11/2002 Miles
 2003/0055375 A1 3/2003 Holst
 2005/0267401 A1 12/2005 Price
 2005/0278054 A1 12/2005 Gaines et al.

FOREIGN PATENT DOCUMENTS

JP 11-002358 A 1/1999
 WO 9720594 A1 6/1997
 WO 0126714 A1 4/2001
 WO 2004028595 A1 4/2004

OTHER PUBLICATIONS

USPTO Office action issued in U.S. Appl. No. 10/853,958 dated Mar. 18, 2008, 8 pages.
 Office action dated Mar. 24, 2009 from related U.S. Appl. No. 11/961,158, 8 pgs.
 European Search Report for EP 05753418.2, dated Apr. 9, 2009, 7 pgs.
 Office action dated Oct. 21, 2009 from related U.S. Appl. No. 11/961,158, 8 pgs.
 Response filed Jan. 26, 2010 to Office action dated Oct. 21, 2009 from related U.S. Appl. No. 11/961,158, 12 pgs.

* cited by examiner

FIG. 1

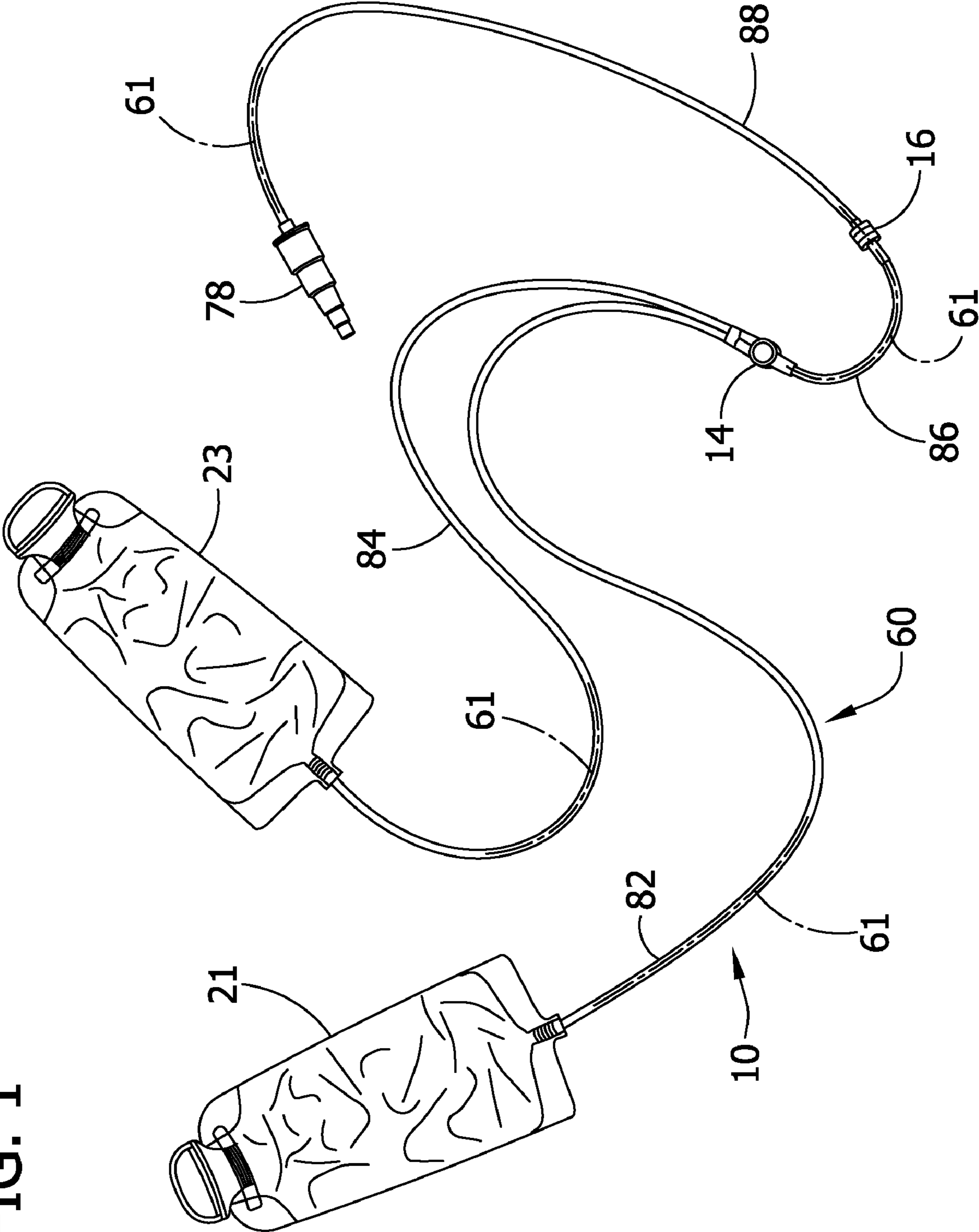

FIG. 2A

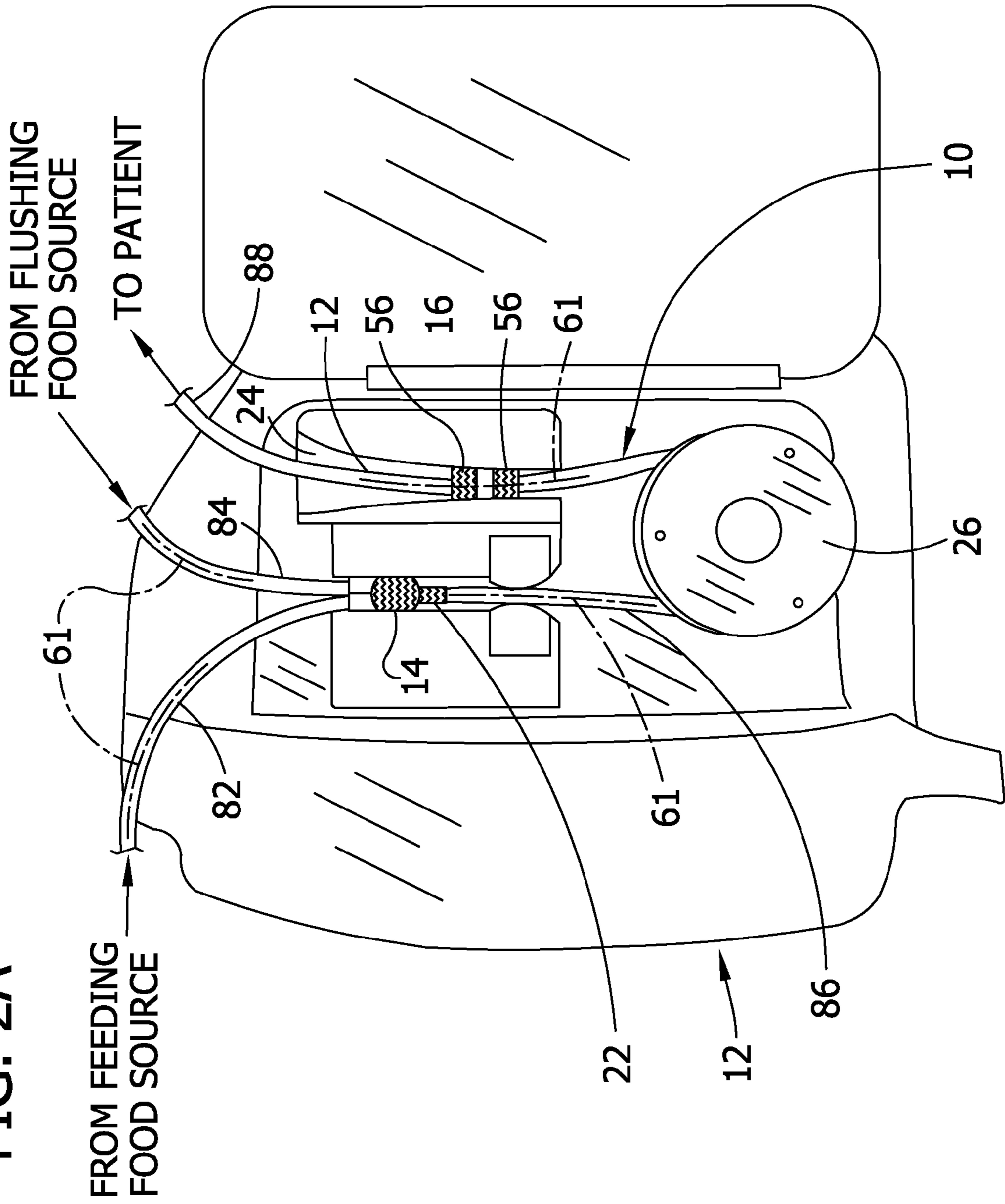
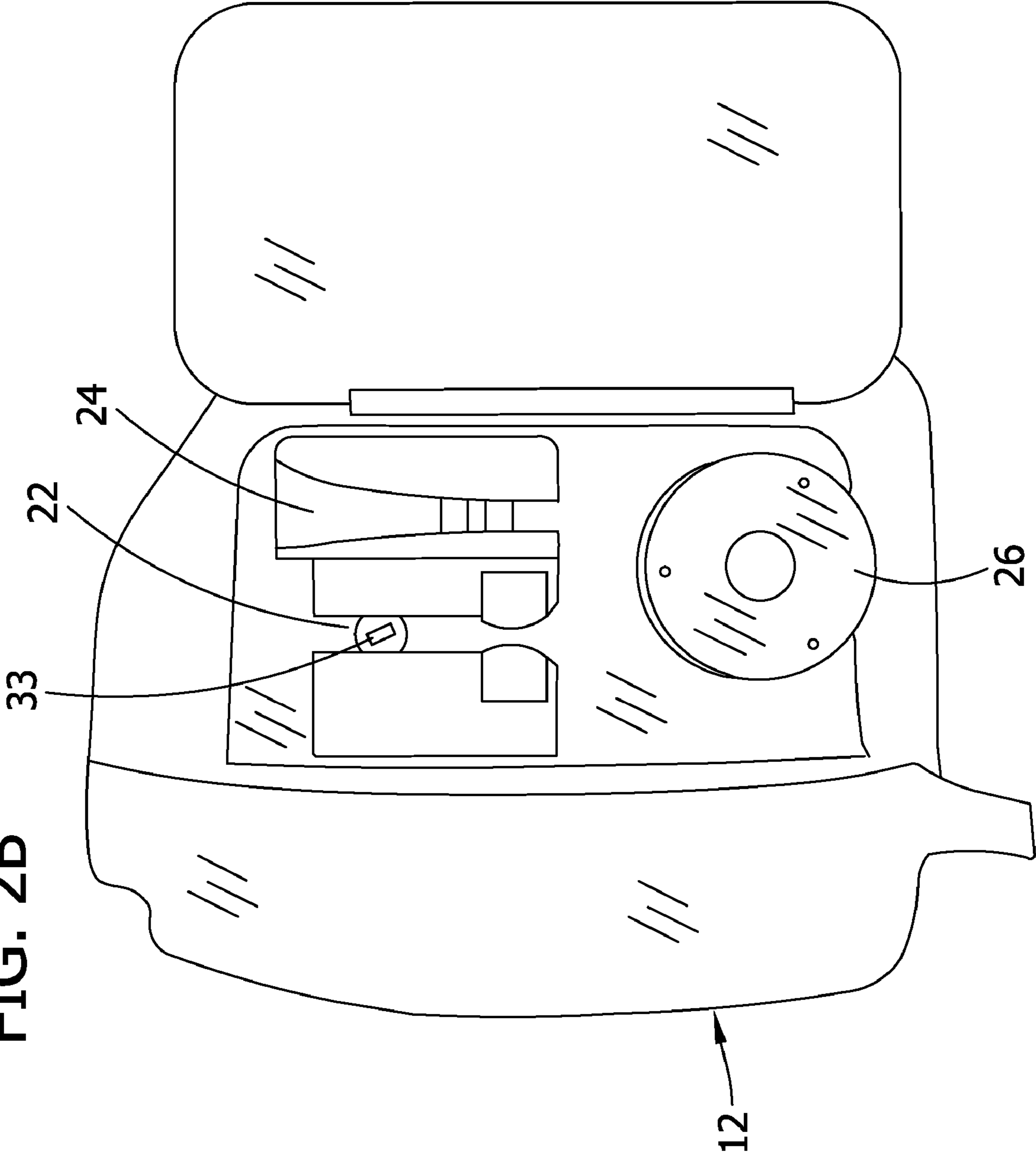

FIG. 2B



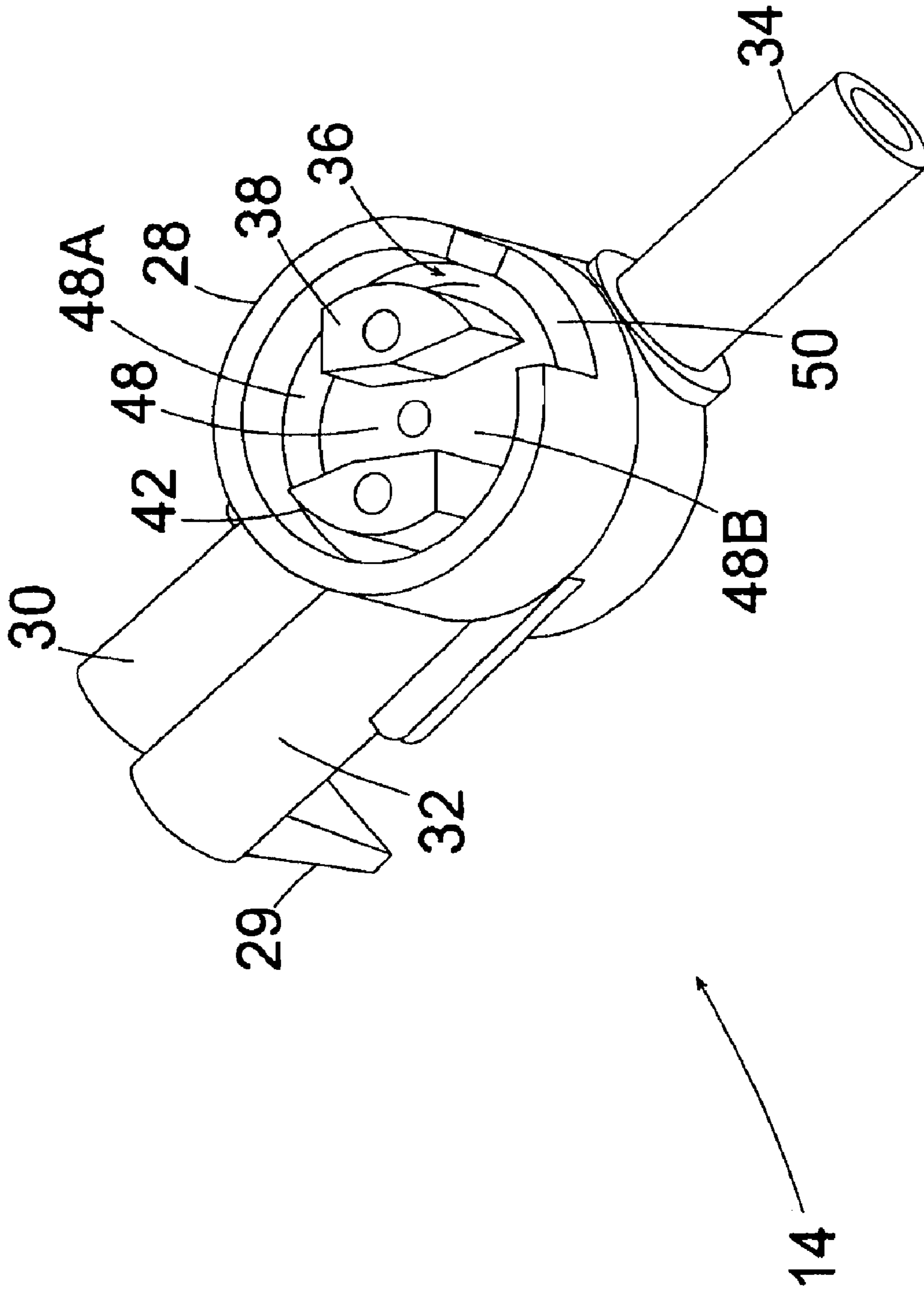

Fig. 3A

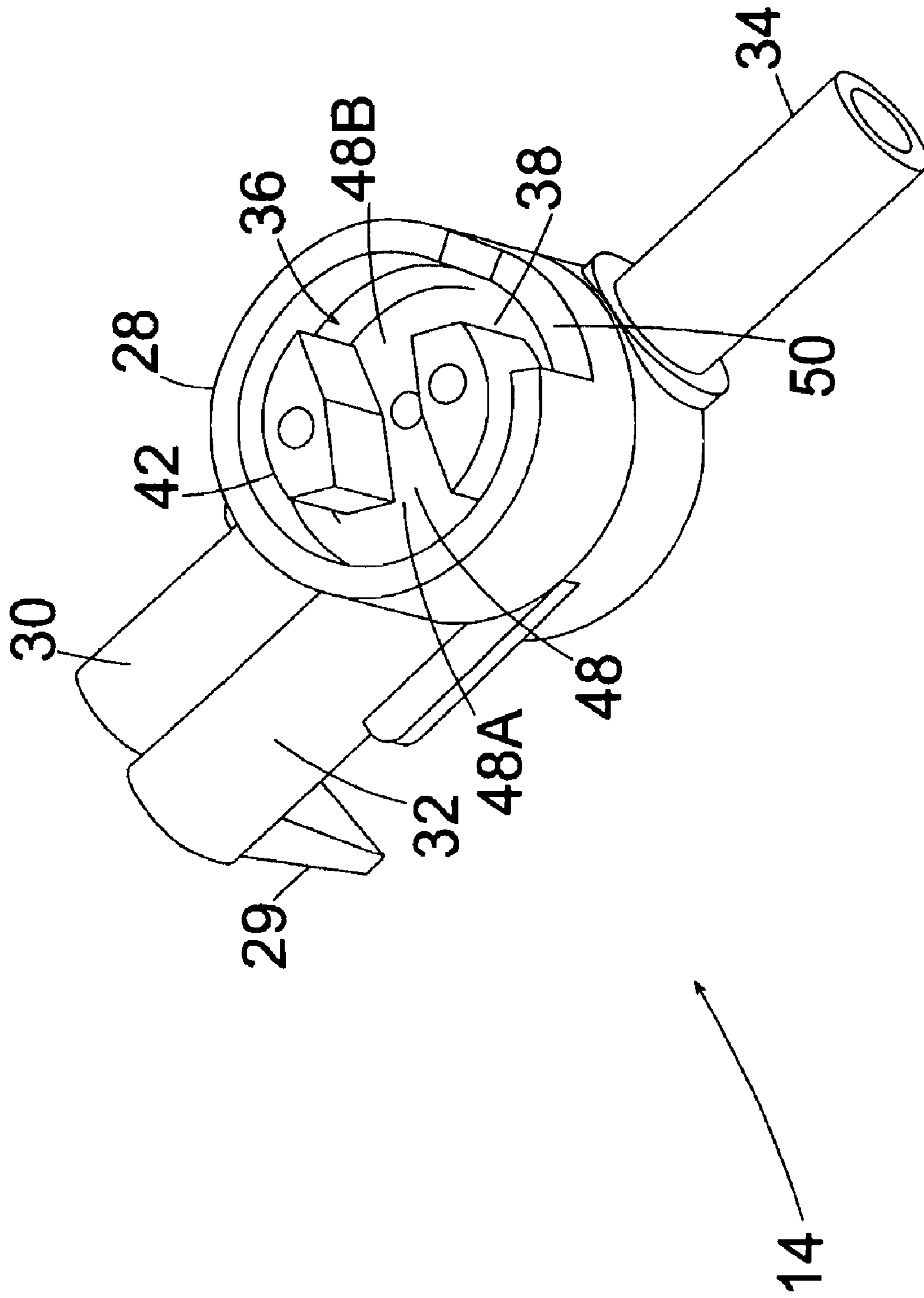

Fig. 3B

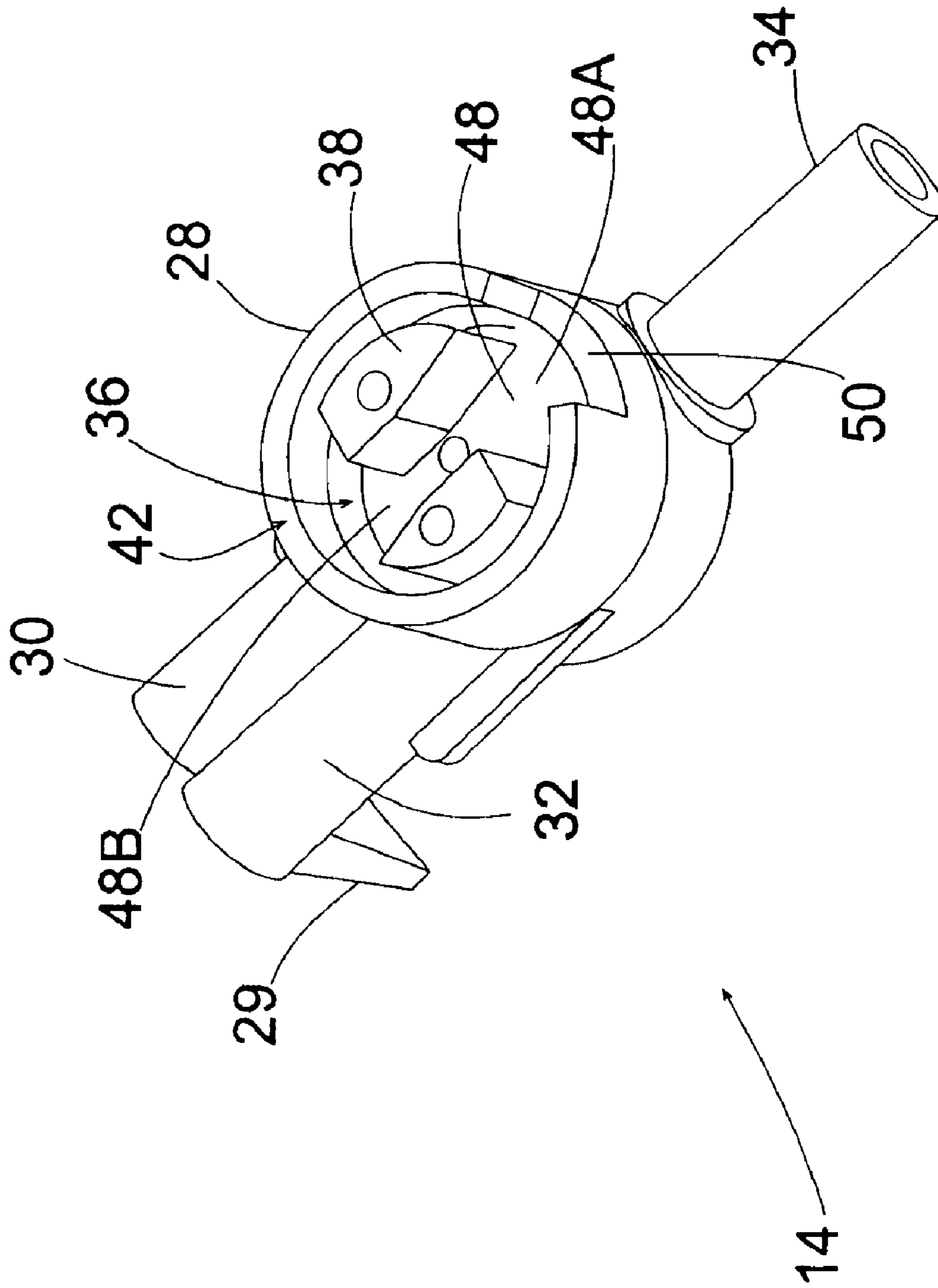
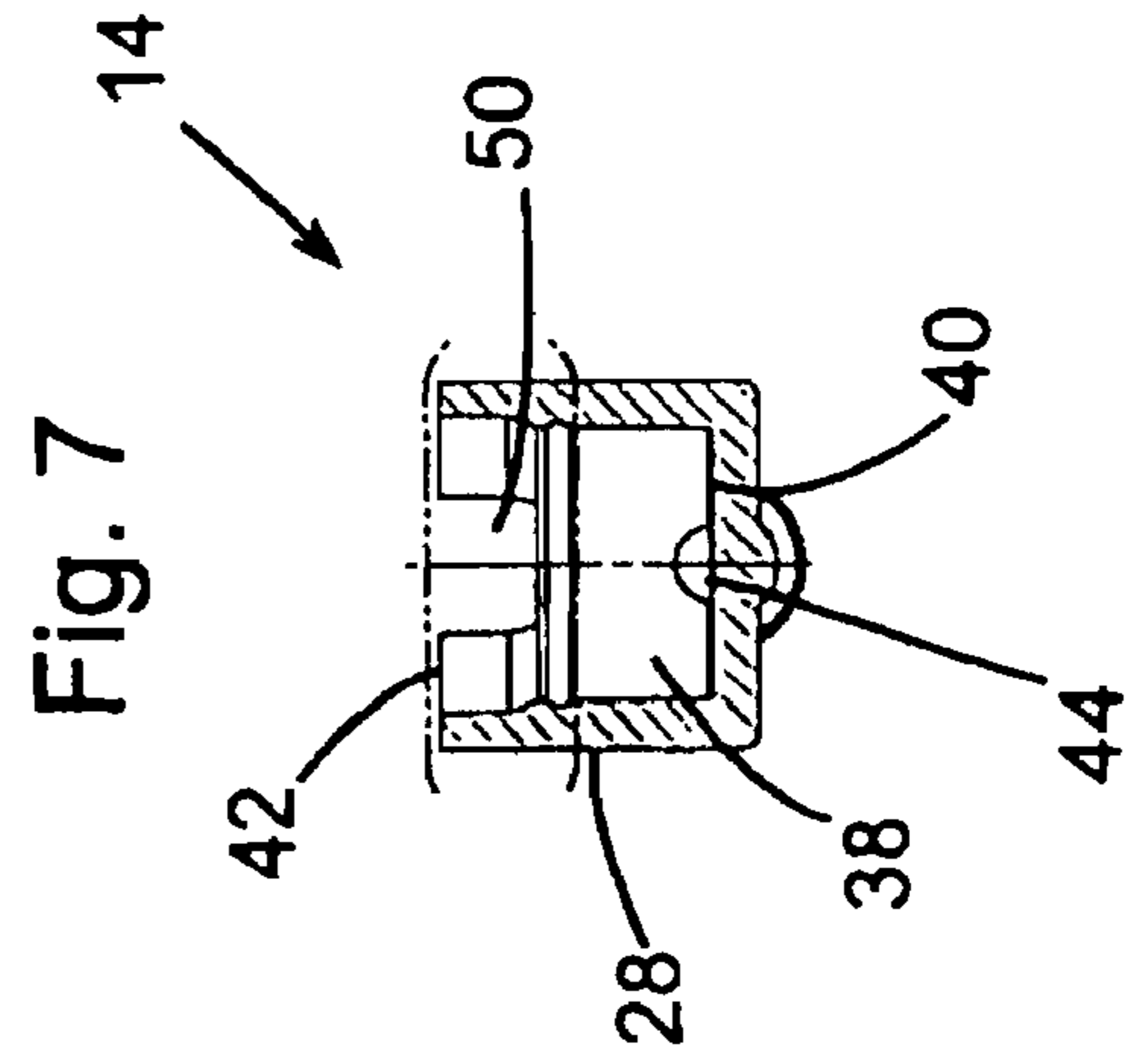
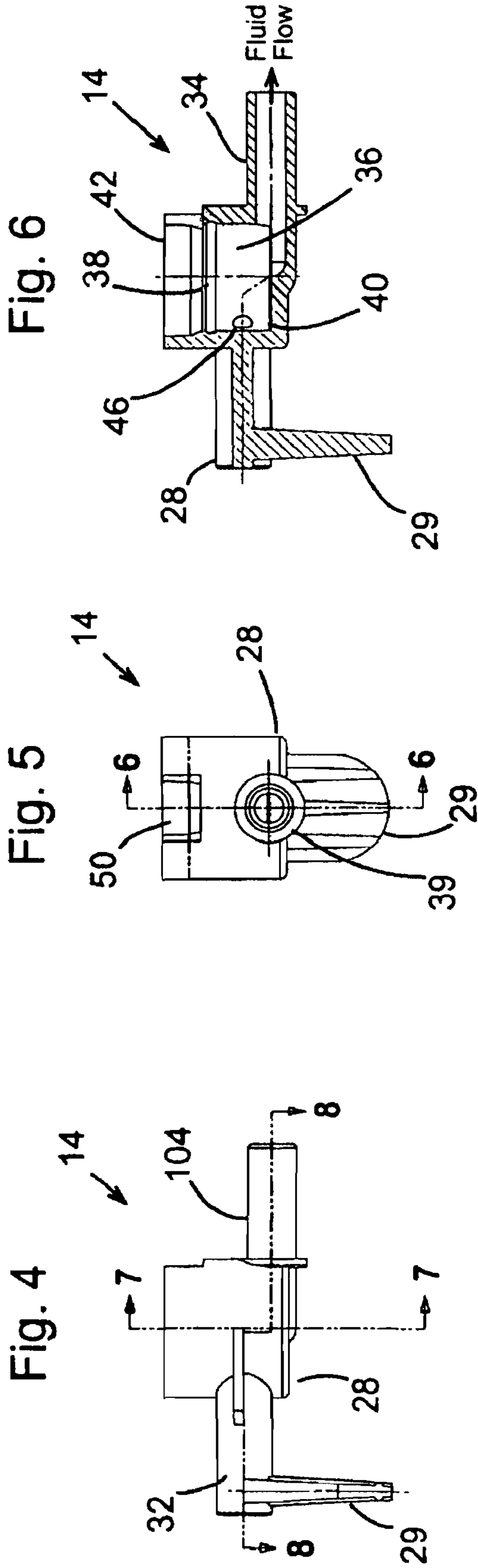

Fig. 3C



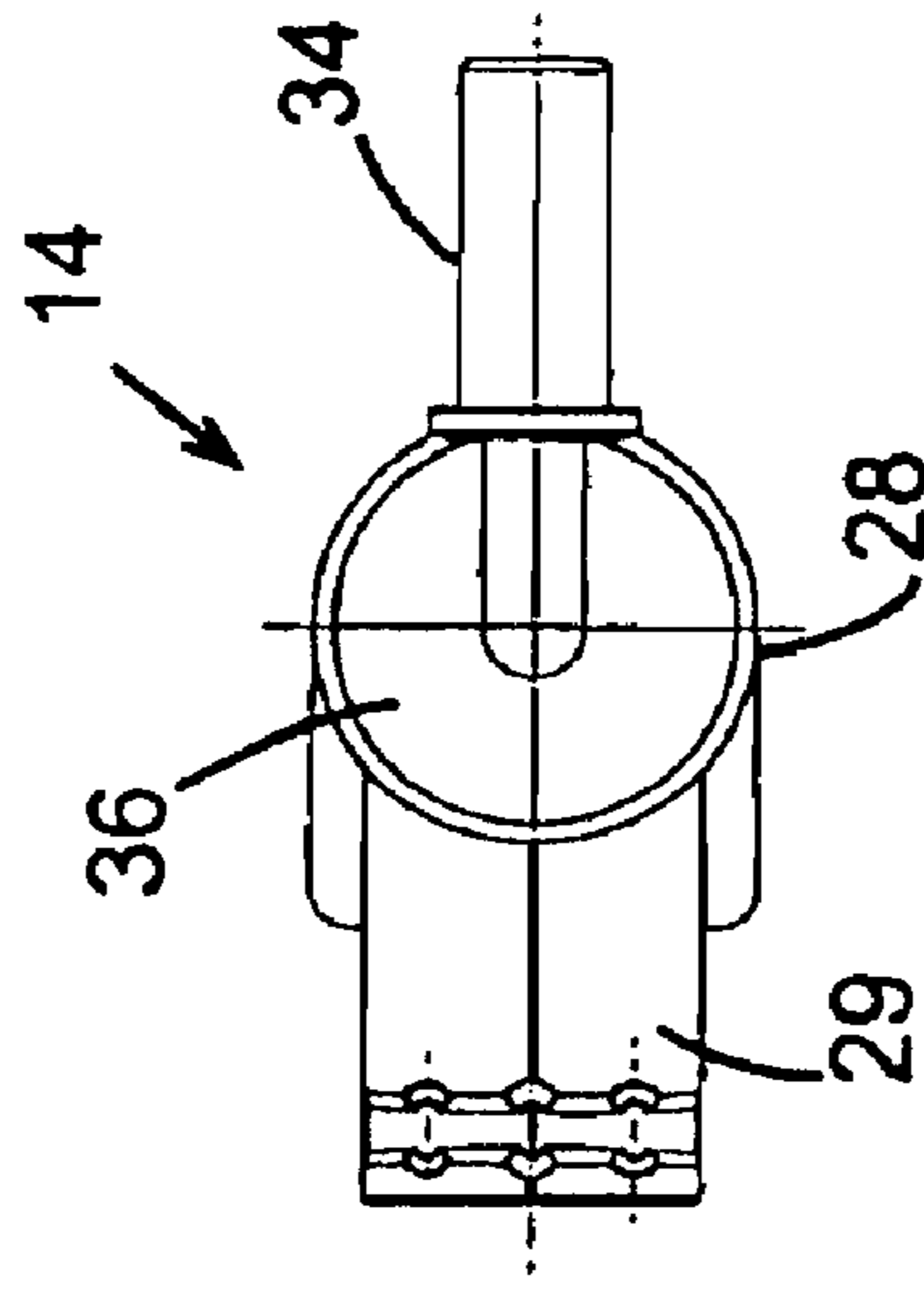

Fig. 8

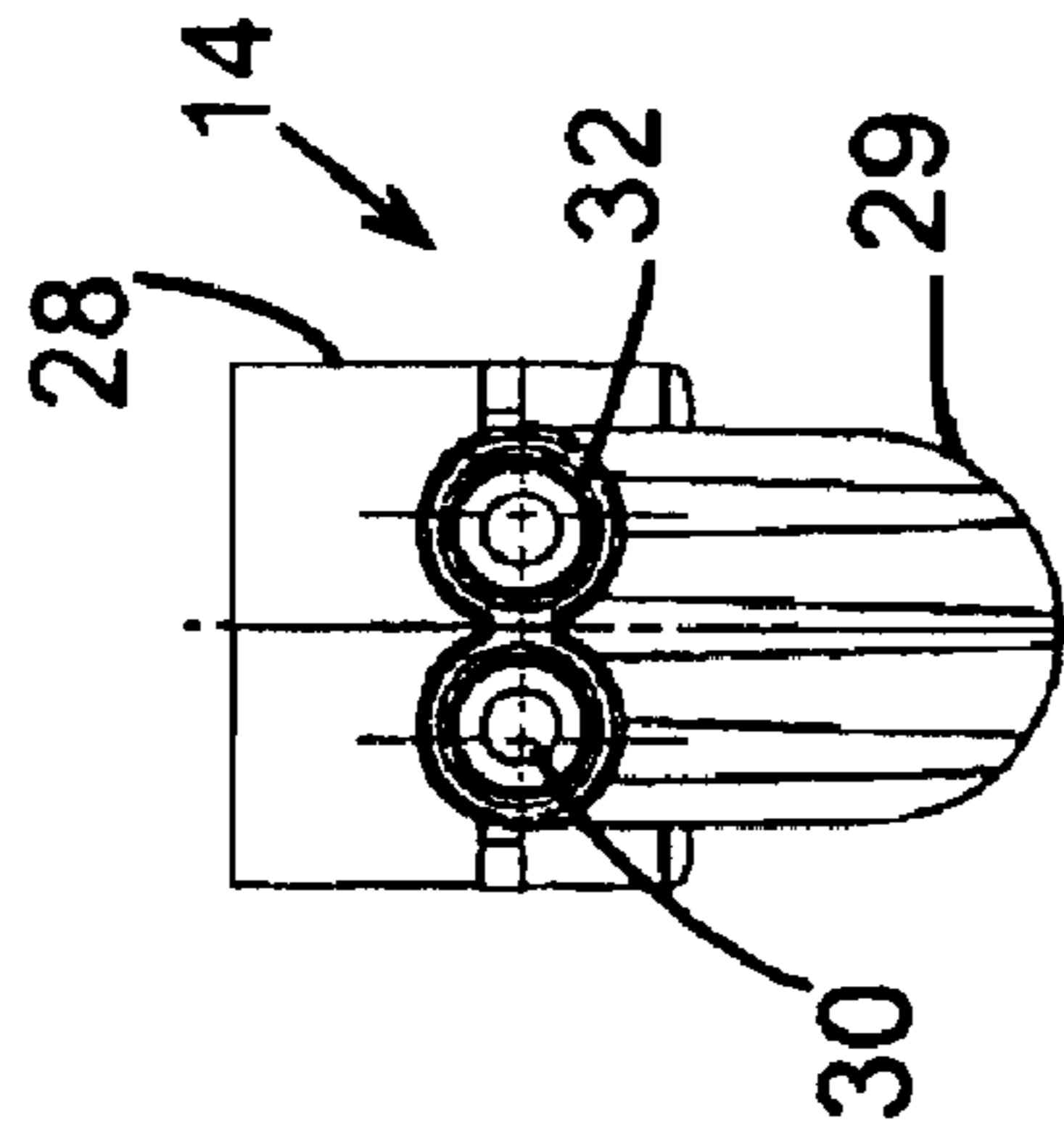

Fig. 9

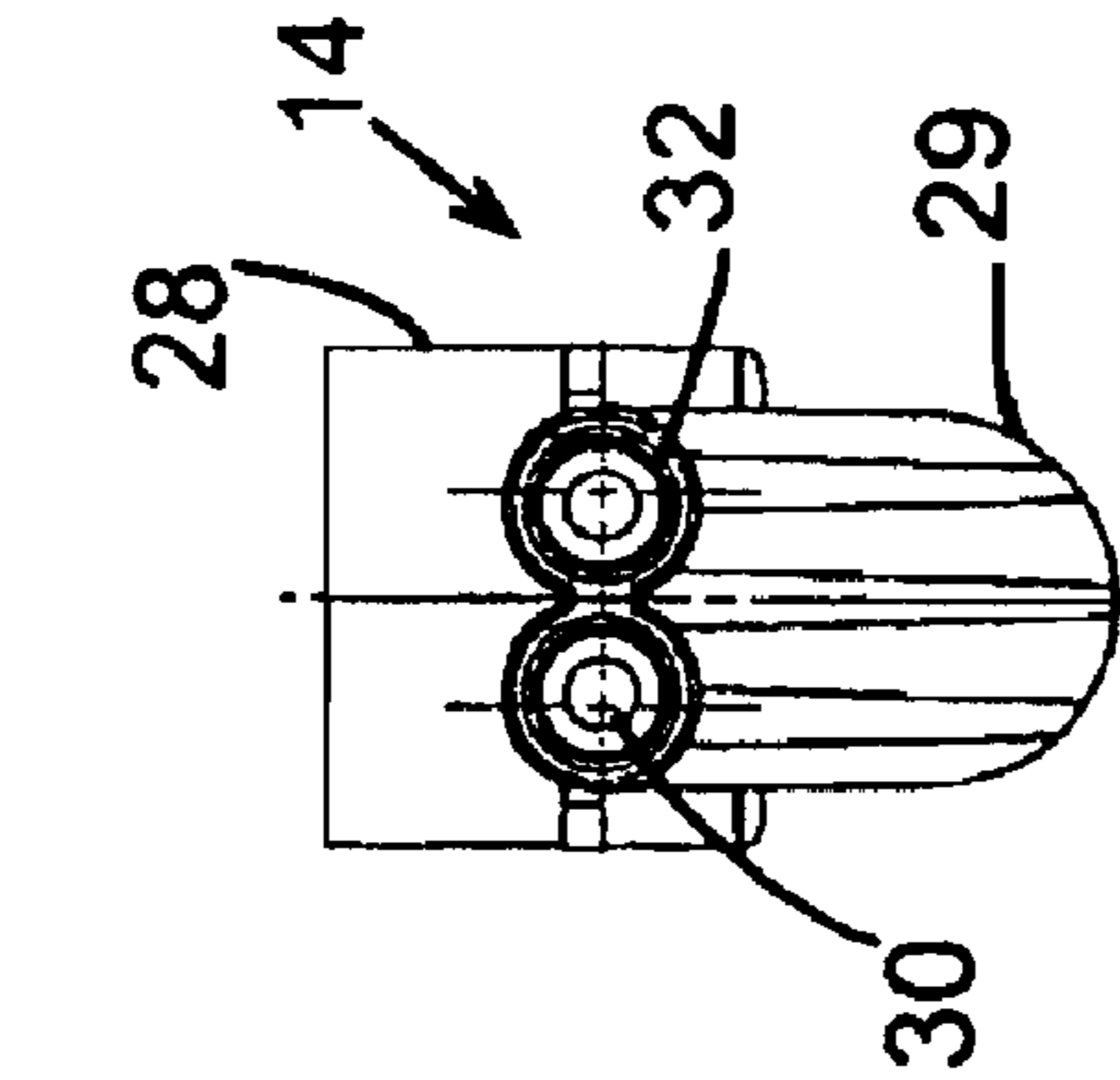

Fig. 10

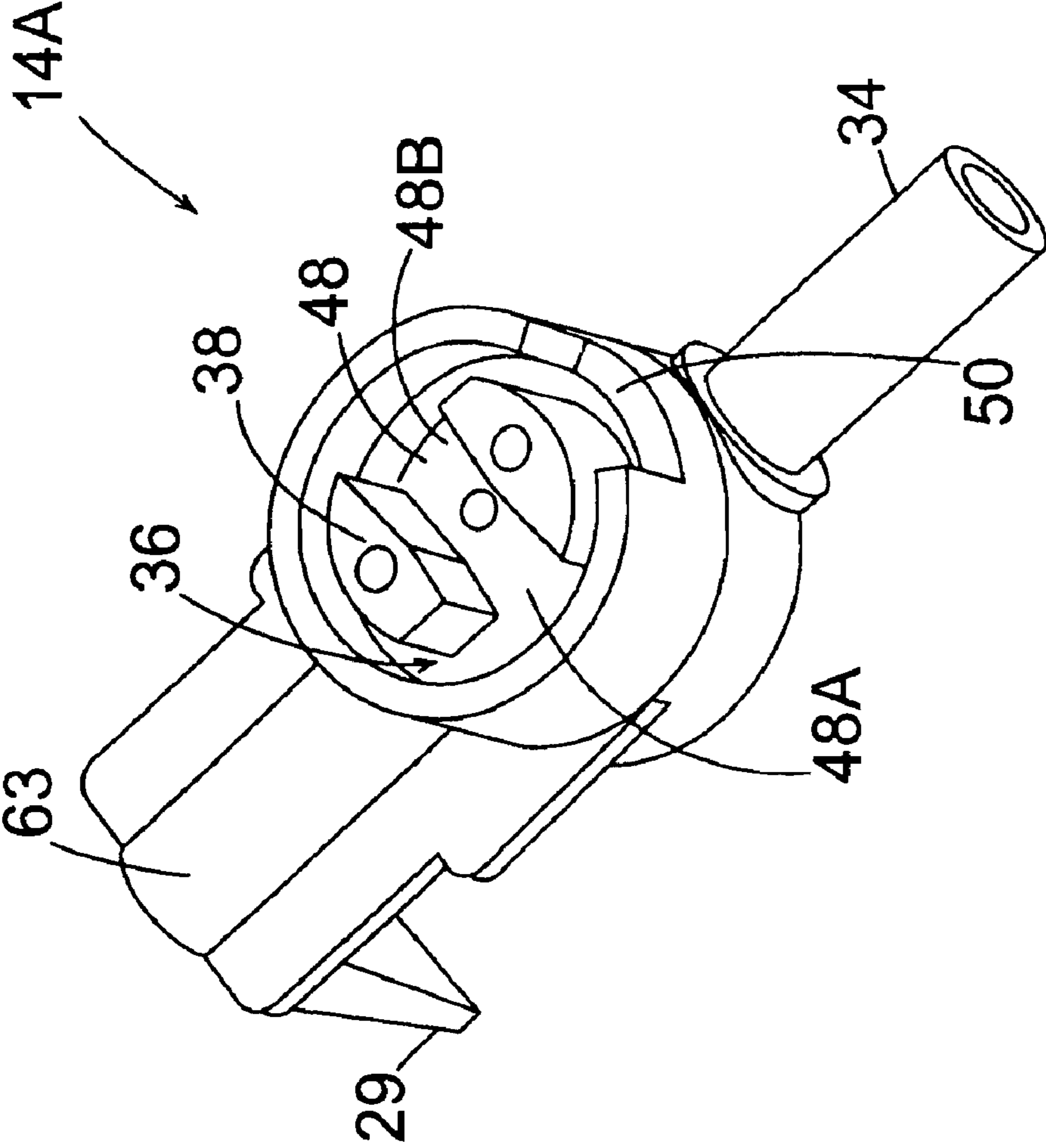

Fig. 11A

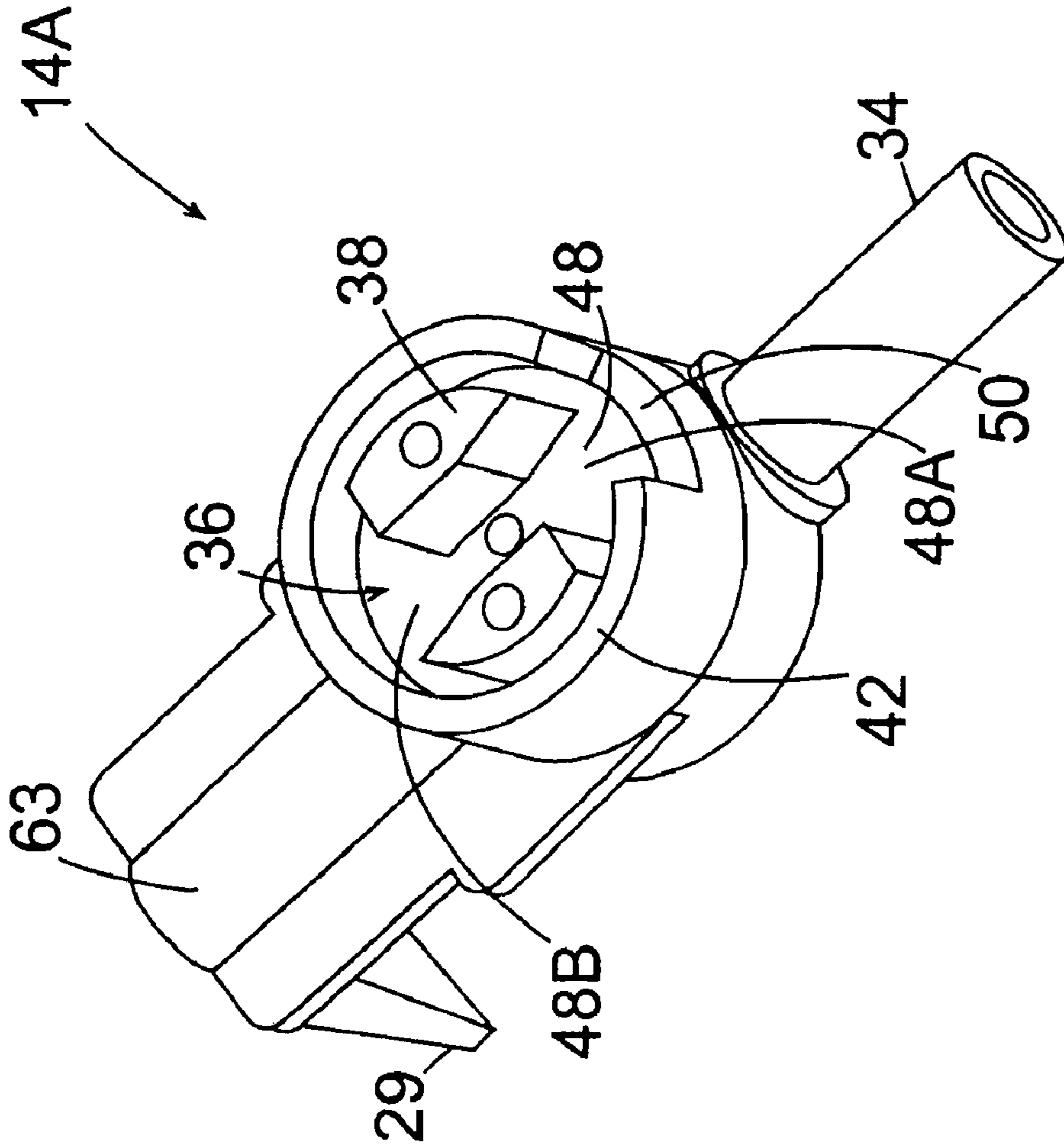

Fig. 11B

FIG. 12

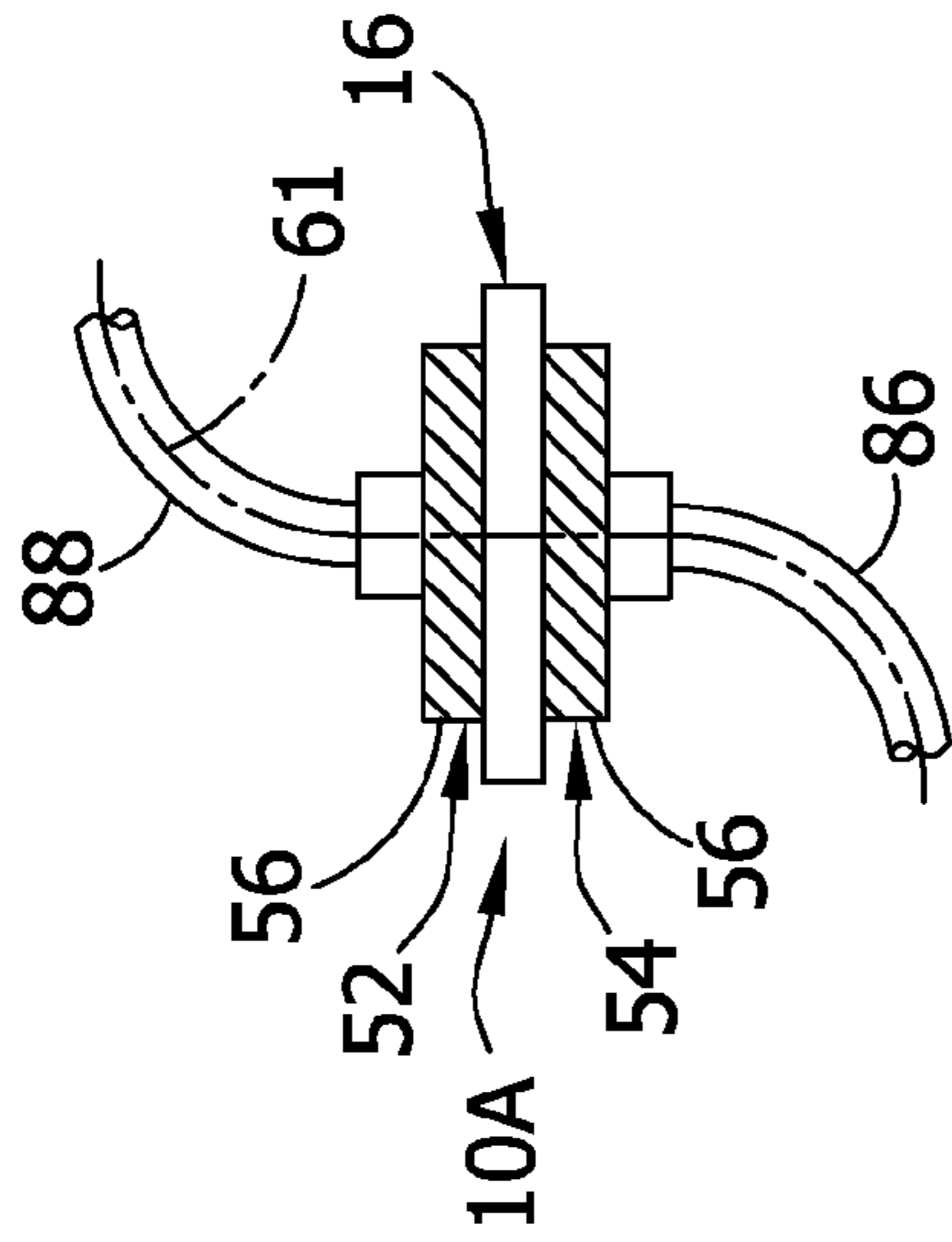

FIG. 13

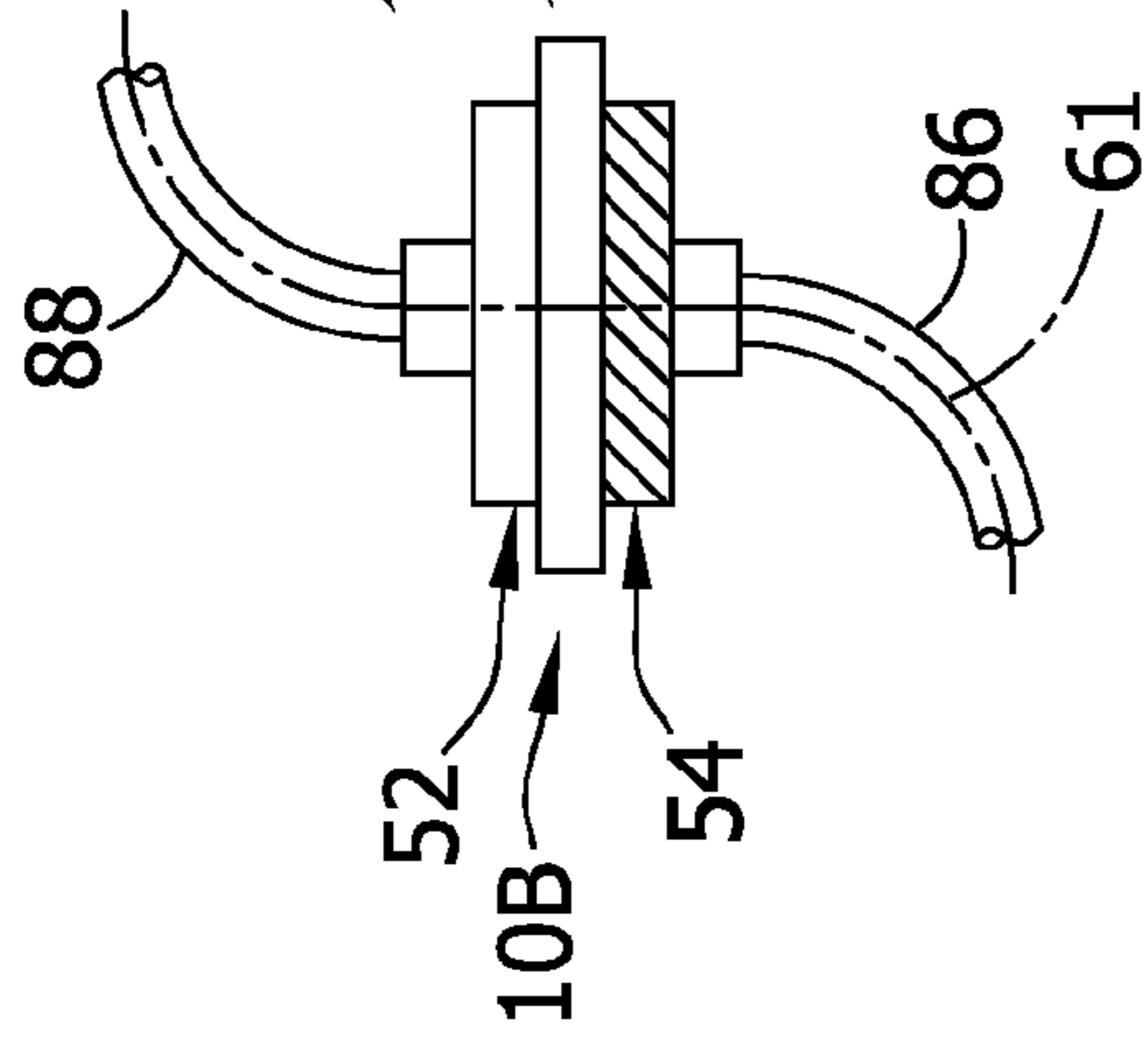

FIG. 14

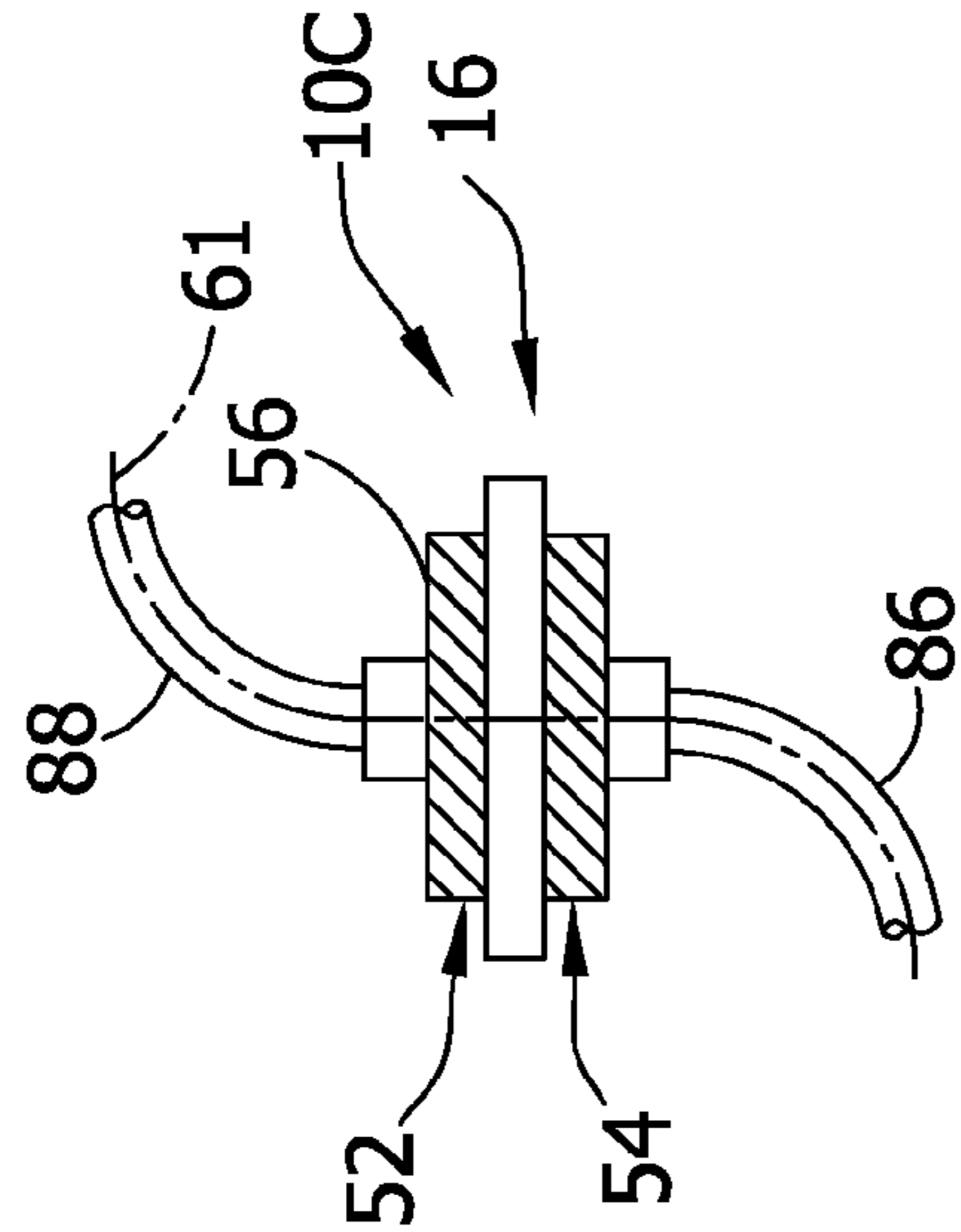

FIG. 15

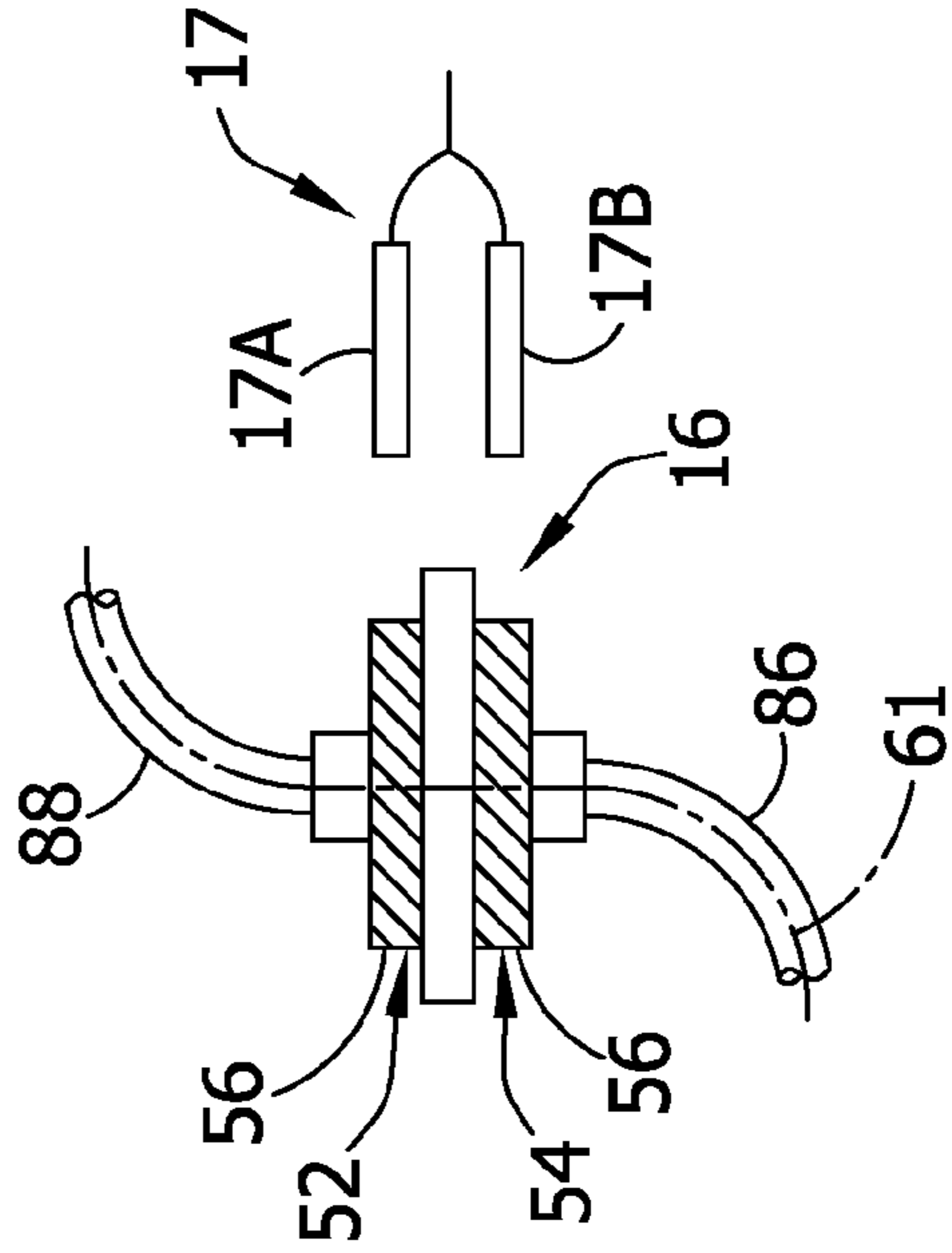

FIG. 16

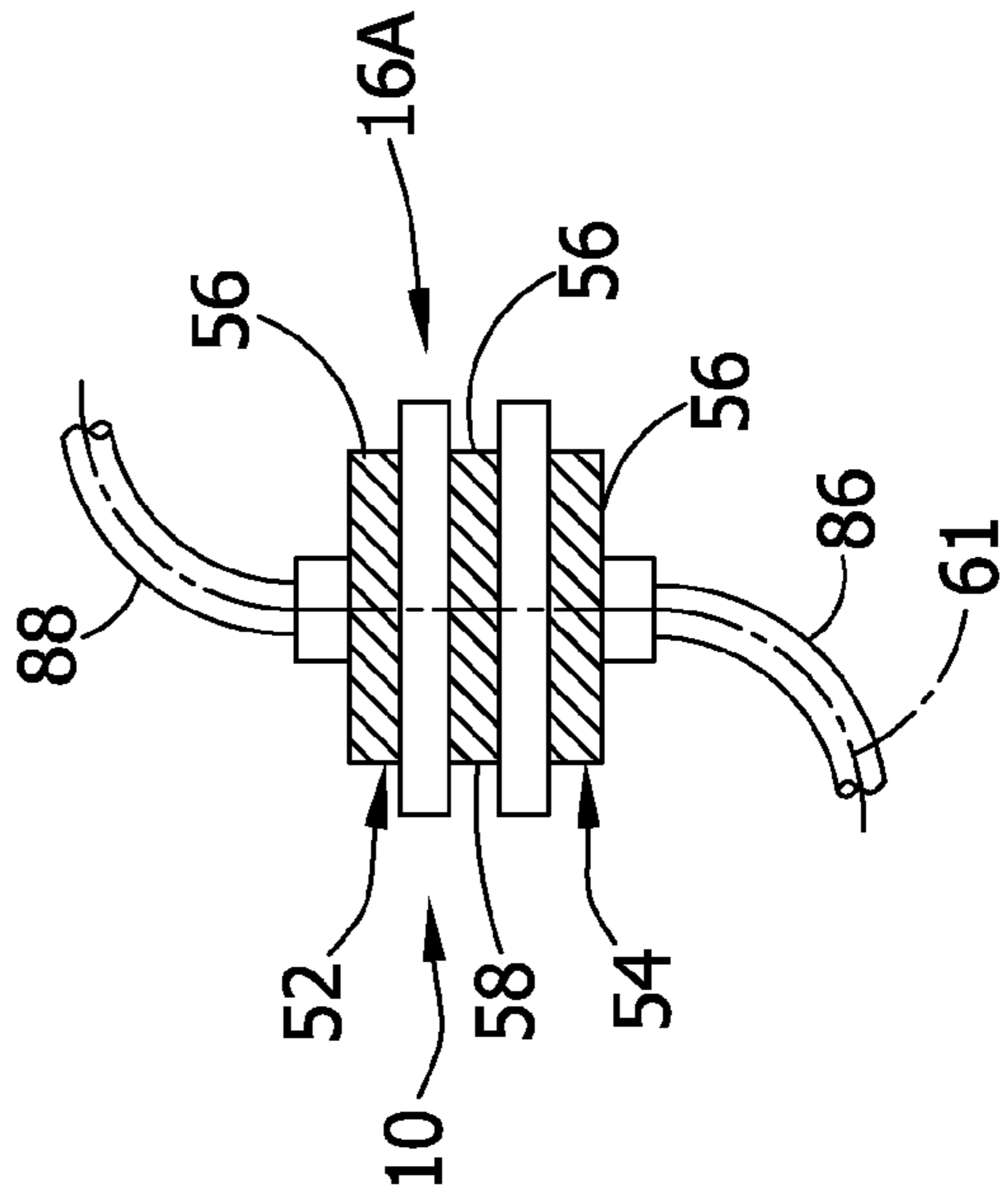

FIG. 17

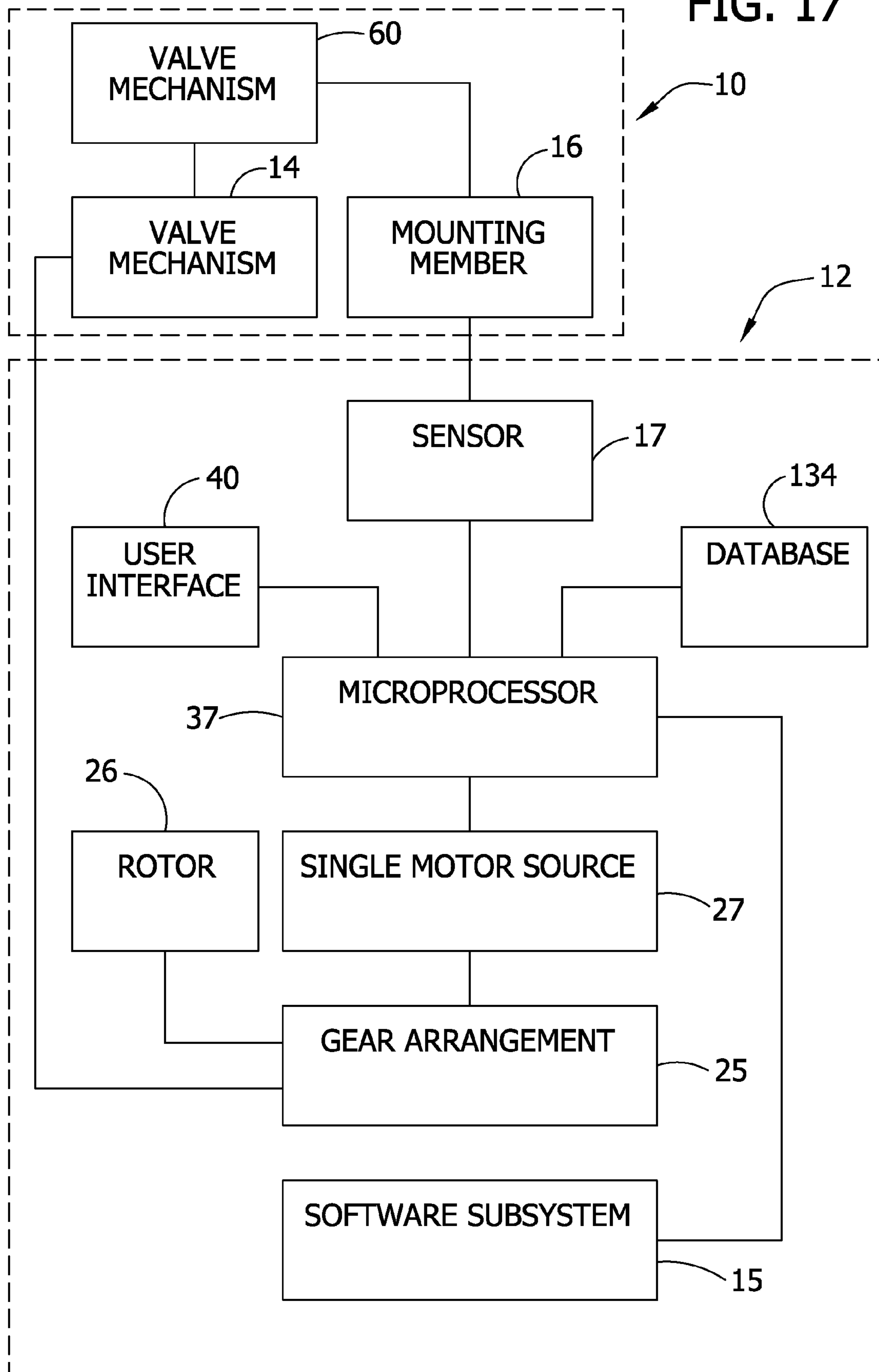
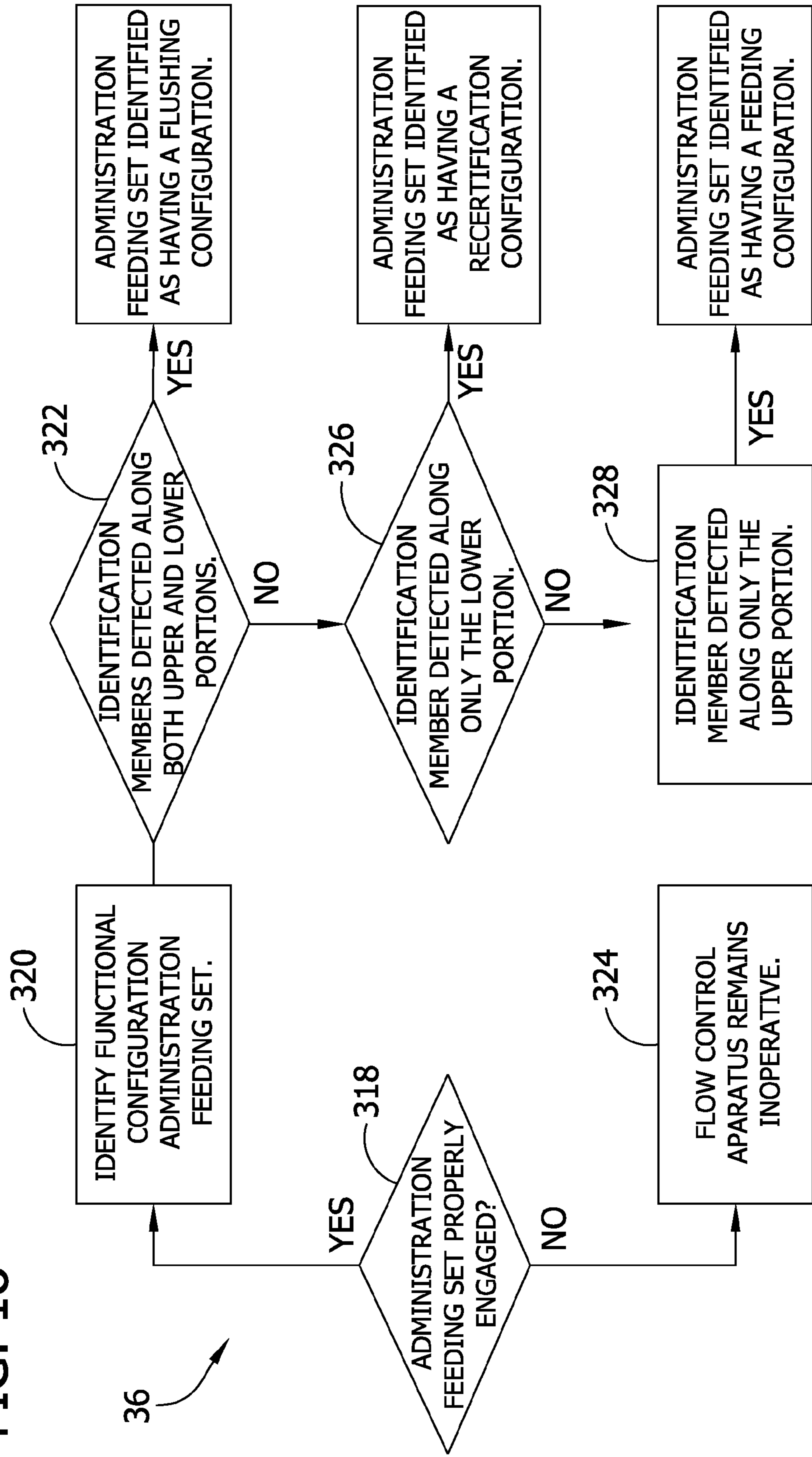

FIG. 18



1**ADMINISTRATION FEEDING SET****CROSS-REFERENCE TO RELATED APPLICATION**

This application is a divisional application of pending U.S. patent application Ser. No. 10/853,958, filed May 25, 2004, the entirety of which is hereby incorporated by reference.

FIELD OF THE INVENTION

The present invention relates to an administration feeding set adapted to be loaded to a flow control apparatus. The present invention further relates to a valve mechanism adapted to be engaged to a flow control apparatus.

BACKGROUND OF THE INVENTION

Administering fluids containing medicine or nutrition to a patient is well known in the art. Typically, fluid is delivered to the patient by an administration feeding set loaded to a flow control apparatus, such as a peristaltic pump, which delivers fluid to the patient at a controlled rate of delivery. The administration feeding set, when loaded to the flow control apparatus, comprises tubing that delivers fluid from a fluid source to a patient.

A valve mechanism may be located on the tubing for permitting or presenting fluid flow communication through the administration feeding set. Such a valve mechanism may be automatically operated to alternate positions that either prevent or permit fluid flow communication through the tubing when engaged to the flow control apparatus.

Often times it may be difficult to identify administration feeding sets having different functional configurations for performing different kinds of tasks since each type of administration feeding set has a physical appearance that may be indistinguishable from other kinds of administration feeding sets. Accordingly, it is important that the healthcare practitioner be able to readily identify the functional configuration of the administration feeding set being loaded to the flow control apparatus.

Therefore, there is a need for an administration feeding set having a means for identifying the functional configuration of the feeding set and having a valve mechanism that can prevent disengagement of the administration feeding set loaded to the flow control apparatus.

SUMMARY OF THE INVENTION

In one embodiment, an administration feeding set is adapted for use with a flow control apparatus to deliver fluid from at least one fluid source to a patient. The administration feeding set comprises tubing for flow of fluid along a fluid pathway, and a mounting member on the tubing adapted to engage the flow control apparatus. The mounting member has at least two receiving portions co-axial with the fluid pathway. Each receiving portion is adapted to receive an identification member. The administration feeding set also includes one or more identification members selectively positioned on one or more of the at least two co-axial receiving portions of the mounting member to permit identification of the administration feeding set as having a particular functional configuration different from another functional configuration.

BRIEF DESCRIPTION OF THE DRAWINGS

FIG. 1 is a perspective view of an embodiment of the administration feeding set according to the present invention;

2

FIG. 2A is a side view of the administration feeding set loaded to a flow control apparatus according to the present invention;

FIG. 2B is a side view of an embodiment of a flow control apparatus prior to loading the administration feeding set thereto according to the present invention;

FIG. 3A is a partial perspective view of an embodiment of the valve mechanism shown in the feeding position according to the present invention;

FIG. 3B is a partial perspective view of the embodiment of the valve mechanism shown in the flushing position according to the present invention;

FIG. 3C is a perspective view of the embodiment of the valve mechanism shown in the blocking position according to the present invention;

FIG. 4 is a side view of the embodiment of the valve mechanism according to the present invention;

FIG. 5 is an end view of the embodiment of the valve mechanism according to the present invention;

FIG. 6 is a cross-sectional view of the embodiment of the valve mechanism taken along line 6-6 of FIG. 5 according to the present invention;

FIG. 7 is a cross-sectional view of the embodiment of the valve mechanism taken along line 7-7 of FIG. 4 according to the present invention;

FIG. 8 is a cross-sectional view of the embodiment of the valve mechanism taken along line 8-8 of FIG. 4 according to the present invention;

FIG. 9 is an opposing end view of the embodiment of the valve mechanism according to the present invention;

FIG. 10 is a bottom view of the embodiment of the valve mechanism according to the present invention;

FIG. 11A is a perspective view of an alternative embodiment of the valve mechanism shown in the feeding position according to the present invention;

FIG. 11B is a perspective view of the alternative embodiment of the valve mechanism shown in the blocking position according to the present invention;

FIG. 12 is a diagram of an embodiment of the mounting member with identification members attached to the lower and upper portions thereof according to the present invention;

FIG. 13 is a diagram of an embodiment of the mounting member with an identification member attached only to the lower portion thereof according to the present invention;

FIG. 14 is a diagram of an embodiment of the mounting member with an identification member attached only to the upper portion thereof according to the present invention;

FIG. 15 is a diagram of an embodiment of the mounting member with the identification members attached to the upper and lower portions and further illustrating the related sensor devices according to the present invention;

FIG. 16 is a diagram of an alternative embodiment of a mounting member with identification members attached to upper, middle and lower portions according to the present invention;

FIG. 17 is a simplified block diagram illustrating the various systems related to the administration feeding set loaded to the flow control apparatus according to the present invention; and

FIG. 18 is a flow chart of the software subsystem illustrating the process used to detect and identify a functional configuration of an administration feeding set adapted to be loaded to the flow control apparatus according to the present invention.

DESCRIPTION OF THE PREFERRED EMBODIMENTS

Referring to the drawings, an embodiment of the administration feeding set according to the present invention is illustrated and generally indicated as **10** in FIG. 1. This embodiment comprises an administration feeding set **10** adapted to be loaded to a flow control apparatus **12** suitable for delivery of fluid to a patient. In particular, the administration feeding set **10** comprises tubing **60** adapted for fluid flow communication and further adapted to engage the flow control apparatus **12** suitable for driving fluid through the tubing **60**. A valve mechanism **14** is in direct communication with the tubing **60** and is adapted to permit or prevent fluid flow communication through the tubing **60** when valve mechanism **14** is engaged to the flow control apparatus **12**. In addition, the administration feeding set **10** comprises a mounting member **16** in direct communication with the tubing **60**, wherein the mounting member **16** permits identification of the functional configuration of the administration feeding set **10** by the flow control apparatus **12** upon engagement of the mounting member **16** to the flow control apparatus **12**. The mounting member **16** also assists in the loading of the administration feeding set **10** to the flow control apparatus **12**. As used herein, the term load means that the valve mechanism **14** and mounting member **16** are engaged to flow control apparatus **12** and tubing **60** is placed in a stretched condition between valve mechanism **14** and mounting member **16** such that the administration feeding set **10** is ready for operation with flow control apparatus **12**.

In another embodiment, the administration feeding set **10** is identical to the previous embodiment with the exception that the valve mechanism **14** is absent.

In yet another embodiment of the present invention there is provided a novel valve mechanism **14** adapted to be engaged to flow control apparatus **12**. The valve mechanism **14** is suitable for permitting or presenting fluid flow communication, as well as preventing disengagement of the valve mechanism **14** from flow control apparatus **12** when the valve mechanism **14** is in a position that permits fluid flow communication.

Administration Feeding Set

As noted above, the administration feeding set **10** comprises tubing **60** that provides a fluid pathway **61** between at least one source of fluid and a patient. Tubing **60** comprises first tubing **86** engaged between the valve mechanism **14** and mounting member **16**, and second tubing **88** engaged between mounting member **16** and a connector **78**, such as a barbed connector, suitable for attachment to a gastrostomy device attached to a patient. The valve mechanism **14** and mounting member **16** are adapted to engage the tubing **60** to the flow control apparatus **12**. As further shown, tubing **60** further comprises third tubing **82** engaged between a feeding fluid source **21** and valve mechanism **14**, and fourth tubing **84** engaged between a flushing fluid source **23** and valve mechanism **14**, wherein the valve mechanism **14** provides a means for permitting flow of feeding fluid or flushing fluid, or preventing fluid flow communication through tubing **60**.

Referring to FIGS. 2A, 2B and 17 exemplary components and systems of the administration feeding set **10** and flow control apparatus **12** according to an embodiment of the present invention are illustrated. Flow control apparatus **12** comprises a housing **20** that defines first and second recesses **22** and **24** adapted to load the administration feeding set **10** to flow control apparatus **12**. A means for driving fluid through tubing **60**, such as a rotor **26**, is operatively engaged to and through the housing **20** and is adapted to engage tubing **60**.

Flow control apparatus **12** further includes a sensor **17** (FIG. 15) that detects the engagement of mounting member **16** to second recess **24** and is in operative communication with a software subsystem **15** as explained in greater detail below. The valve mechanism **14** and rotor **26** are operatively engaged to a gear arrangement **25** driven by a single motor source **27**. A suitable flow control apparatus **12** is disclosed in co-pending patent application Ser. No. 10/854,136 (Publication No. 2005/0267439) filed on even date herewith and herein incorporated by reference in its entirety. However, it is understood that any suitable flow control apparatus **12** may be used with administration feeding set **10**.

As noted above, administration feeding set **10** comprises tubing **60** engaged to valve mechanism **14** and mounting member **16** adapted for loading the administration feeding set **10** to flow control apparatus **12**. Referring specifically to FIGS. 2A and 2B, to load the administration feeding set **10** to the flow control apparatus **12**, the valve mechanism **14** is engaged to first recess **22**, the first tubing **86** then wrapped around rotor **26**, and the mounting member **16** engaged to second recess **24** such that first tubing **86** is placed in a stretched condition around rotor **26** and the administration feeding set **10** is ready for operation with flow control apparatus **12**.

As used herein, the portion of tubing **60** leading to the rotor **26** is termed upstream, while the portion of tubing **60** leading away from the rotor **26** is termed downstream. Valve mechanism **14** is engaged to the upstream portion of tubing **60** at first recess **22** and controls the flow of fluid from the respective fluid source through administration feeding set **10**, while the mounting member **16** is engaged to the downstream portion of tubing **60** at second recess **24** for loading the administration feeding set **10** to flow control apparatus **12**. In an embodiment illustrated in FIG. 1, the feeding fluid source **21** and the flushing fluid source **23** are placed in fluid flow communication with valve mechanism **14** through tubing **60** for permitting or preventing fluid flow from either the feeding or flushing fluid sources **21**, **23**. However, in another embodiment of the administration feeding set **10**, valve mechanism **14** is absent and a means (not shown) for controlling fluid flow through tubing **60** is positioned in an area other than the administration feeding set **10**.

Valve Mechanism

The present invention further relates to a valve mechanism **14** that comprises a valve body **28** having at least one inlet **30**, **32** in communication with an outlet **34** through a chamber **36** and a valve stem **38** rotatably disposed in the chamber **36**. The valve stem **38** has a front portion **40** comprising a fluid pathway **44** defining at least one fluid port **46**. This embodiment of valve mechanism **14** is suitable for controlling fluid flow.

In another embodiment, the valve mechanism **14** comprises a valve body **28** having at least one inlet **30**, **32** in communication with an outlet **34** through a chamber **36** with the valve body **28** further comprising a slot **50**. Valve stem **38** is rotatably disposed in the chamber **36** with the valve stem **38** having a back portion **42** comprising a channel **48**. This embodiment of valve mechanism **14** is suitable for preventing disengagement of the valve mechanism **14** from the flow control apparatus **12** when the valve mechanism **14** is in a position that permits fluid flow.

In yet another embodiment, the valve mechanism **14** comprises a valve body **28** having at least one inlet **30**, **32** in communication with an outlet **34** through a chamber **36** with the valve body **28** further comprising a slot **50**. Valve stem **38** is rotatably disposed in the chamber **36**. The valve stem **38** has a front portion **40** comprising a fluid pathway **44** defining at least one fluid port **46** and a back portion **42** comprising a

5

channel 48. This embodiment of valve mechanism 14 is suitable for controlling fluid flow and for preventing disengagement of the valve mechanism 14 from the flow control apparatus 12 when the valve mechanism 14 is in a position that permits fluid flow.

Referring to FIGS. 3-10, valve mechanism 14 is adapted to be engaged to tubing 50 according to the present invention. As noted above, valve mechanism 14 comprises valve body 28 having a first inlet 30 adapted to be in communication with the feeding fluid source 21 through third tubing 82 and a second inlet 32 adapted to be in communication with a flushing fluid source 23 through fourth tubing 84 for providing fluid flow communication with an outlet 34 through chamber 36 interposed between first and second inlets 30, 32 and outlet 34. Valve body 28 further comprises slot 50 along the periphery thereof that is a structural arrangement adapted to receive a rotatable shaft 33 therethrough for operating the valve mechanism 14 as shall be discussed below. Preferably, valve body 28 includes a tab 29 that enables the user to easily engage valve mechanism 14 to flow control apparatus 10.

As noted above, valve stem 38 has front portion 40 comprising a fluid pathway 44 that defines at least one fluid port 46 to establish fluid flow through valve body 28. Fluid flow is established when valve stem 38 is rotated such that any one fluid port 46 is aligned with either the first or second inlets 30 and 32, thereby establishing fluid flow communication between first or second inlets 30, 32 and outlet 34.

Referring to FIGS. 2B, 3A-C, 6, and 17, channel 48 has opposed openings 48A and 48B adapted to engage rotatable shaft 33 when engaging the valve mechanism 14 to the first recess 22 of flow control apparatus 12. As shown, flow control apparatus 12 further comprises a gear arrangement 25 operatively engaged to rotatable shaft 33 that is driven by the single motor source 27. The engagement between the valve mechanism 14 and the rotatable shaft 33 is accomplished by rotating the valve stem 38 and orienting channel 48 such that one of the openings 48A or 48B is aligned with slot 50 that permits the shaft 33 to be inserted into the interior portion of channel 48. Channel 48 provides a means for preventing disengagement of valve mechanism 14 from flow control apparatus 12 when the channel 48 is rotated to an orientation that misaligns the channel 48 with slot 50 and places the valve mechanism 14 in a position that permits fluid flow communication through tubing 60.

Conversely, the valve mechanism 14 permits disengagement from the flow control apparatus 12 when the channel 48 is rotated to an orientation that aligns one of the opposed openings 48A or 48B with slot 50 and places the valve mechanism 14 in a position that prevents fluid flow communication through tubing 60. More particularly, valve mechanism 14 must be placed in a blocking position that rotates valve stem 38 such that fluid ports 46 are in misalignment with both the first and second inlets 30, 32 to prevent fluid flow communication in order to disengage valve mechanism 14 from housing 20. Then the flow control apparatus 12 directs rotatable shaft 33 through gear arrangement 25 to rotate valve stem 38 such that the valve mechanism 14 is placed in a blocking position shown in FIG. 10 C, channel 48 is aligned with slot 50 while shaft 33 is disengaged through slot 50.

According to one aspect of the present invention, valve mechanism 14 is configured to prevent manual operation thereof by a user such that valve mechanism 14 can be operated only when engaged to the flow control apparatus 12. Specifically, valve stem 38 must be engaged to shaft 33 in order to permit operation of the flow control apparatus 12, thereby making valve mechanism 14 difficult to operate manually and particularly useful as a tamper-proof device.

6

In operation, the rotation of valve stem 38 by the rotatable shaft 33 when driven by single motor source 27 prevents or permits fluid flow communication through administration feeding set 10 by valve mechanism 14. Flow control apparatus 12 further includes a microprocessor 37 that controls the rotation of valve stem 38 so that either first inlet 30 or second inlet 32 is in alignment or misalignment with the fluid ports 46 when permitting or preventing fluid flow communication. When any one of the fluid ports 46 is aligned with either of the first or second inlets 30, 32 fluid is permitted to flow into fluid port 46, through fluid pathway 44 and then exit out from outlet 34 as illustrated in FIGS. 3A, 3B and 6. Valve stem 38 is rotated in only direction, for example counter-clockwise, such that the valve stem 38 rotates the fluid pathway 44 in one direction only when aligning or misaligning any one of the fluid ports 46 with either first or second inlets 30, 32, thereby permitting a one-way, multiple engagement operation between the fluid ports 46 and first and second inlets 30, 32 that either permits or prevents fluid flow communication. Referring specifically to FIG. 6, when valve stem 38 aligns any one of fluid ports 46 with either first or second inlets 30, 32, fluid flow communication is established between either first or second inlets 30, 32 and outlet 34.

Based on the foregoing, when any one of the fluid ports 46 of valve stem 38 is aligned with any one of the first or second inlets 30, 32 to permit fluid flow communication the channel 48 is misaligned with slot 50, thereby preventing disengagement of the valve mechanism 14 from the flow control apparatus 12. When the fluid ports 46 are misaligned with the first and second inlets 30, 32 to prevent fluid flow communication the channel 48 is aligned with slot 50, thereby permitting disengagement of the valve mechanism 14 from flow control apparatus 12.

Referring to FIGS. 11A and 11B, an alternative embodiment of the valve mechanism designated 14A is illustrated according to the present invention. Valve mechanism 14A is similar in structure and operation to the preferred embodiment of valve mechanism 14, except there is only a single feeding inlet 63 for providing feeding fluid through the administration feeding set 10 from the feeding fluid source 21, rather than first and second inlets 30, 32 which permit both feeding and flushing functions. Accordingly, valve mechanism 14A alternates between a feeding position (FIG. 11A) for providing fluid to a patient and a blocking position (FIG. 11B) that prevents fluid flow communication.

Administration Feeding Set Identifier System

According to another aspect of the present invention, mounting member 16 assists in loading the administration feeding set 10 to the flow control apparatus 12 and is in operative communication with software subsystem 15 when engaged to second recess 24 which provides a means for identifying the type of administration feeding set 10. As shown in FIGS. 2A, and 12-17, mounting member 16 has an upper receiving portion 52 and a lower receiving portion 54 each co-axial with the fluid pathway 61 and each adapted to receive an identification member 56 when attached thereto. Preferably, mounting member 16 has a cylindrical shape that concentrically surrounds tubing 60 and surrounds the fluid pathway 61 extending through the mounting member from one end to its opposite end. The mounting member 16 is configured to be engaged to second recess 24 when loading administration feeding set 10 to flow control apparatus 12 such that sensor 17 detects the presence of one or more identification members 56 attached to mounting member 16. Sensor 17 is preferably a Hall-effect sensor or other type of proximity sensor that is positioned near the second recess 24

such that sensor 17 can detect the presence of one or more identification members 56 when the mounting member 16 is engaged to second recess 24.

When mounting member 16 is engaged to second recess 24, the attachment of one or more identification members 56 to mounting member 16 provides a means for allowing software subsystem 15 to identify the functional configuration of the administration feeding set 10 loaded to flow control apparatus 12 and detected by sensor 17. Specifically, the shown in FIG. 12, mounting member 16 has at least one or more identification members 56 attached thereto in accordance with an identification scheme that permits software subsystem 15 to identify the functional configuration of the administration feeding set 10 loaded to flow control apparatus 12. Preferably, identification members 56 attached thereto in accordance with an identification scheme that permits software subsystem 15 to identify the functional configuration of the administration feeding set 10 loaded to flow control apparatus 12. Preferably, identification members 56 are magnetic components or, in the alternative, magnetically-susceptible metallic components capable of detection by sensor 17 without requiring direct physical contact with sensor 17. In order to identify the functional configuration of the administration feeding set 10 loaded to flow control apparatus 12 microprocessor 37 is operatively associated with a database 134 containing one or more identification schemes for identifying different functional configurations for an administration feeding set 10.

According to another aspect of the present invention, an identification member 56 may be attached to the upper portion 52, lower portion 54, or both portions 52 and 54 of mounting member 16. The attachment of at least one identification member 56 to the mounting member 16 will vary to correspond with the number of different functional configurations. Each different functional configuration for an administration feeding set 10 will have a predetermined number and location of identification member(s) 56 attached to mounting member 16 that identifies the administration feeding set 10, such as feeding, flushing or re-certification, when mounting member 16 is detected by the sensor 17 and this data is communicated to the software subsystem 15 through microprocessor 37.

The recognition of the different number and attachment of identification members 56 to mounting member 16 and the identification of the type of functional configuration of administration feeding set 10 loaded to flow control apparatus 12 is based on a two-step process. First, sensor 17 detects the location and number of identification member(s) 56 when mounting member 16 is engaged to second recess 24; and second, software subsystem 15 that is in operative communication with sensor 17 determines the functional configuration of the loaded administration feeding set 10 based on the location and number of identification members 56 detected on mounting member 16 as shall be explained in greater detail below.

Referring to FIG. 15, sensor 17, for use with an embodiment of the software subsystem 15, comprises a pair of sensor devices 17A and 17B that detect the location and number of one or more identification members 56 attached to mounting member 16. Sensor 17 can be any known type of proximity sensor for detecting an identification member 56, preferably a magnetic component, or in the alternative a magnetically-susceptible metallic component, attached to mounting member 16. In addition, sensor 17 may also comprise any number of sensor devices with each sensor device corresponding to a portion of the mounting member 16 for detecting the presence of an identification member 56. In one embodiment, a pair of

magnetic field proximity sensors or magnetic switch-type sensors may be provided, although the present invention contemplates that other types of sensors may be used, such as various inductive coil arrangements. Sensor 17 is positioned near to second recess 24 such that each sensor device 17A and 17B is positioned relative to a corresponding portion in close proximity with mounting member 16 when administration feeding set 10 is loaded to flow control apparatus 12. Upon engagement of mounting member 16, sensor 17A and sensor 17B are capable of detecting the presence of an identification member 56 attached to the corresponding upper and lower portions 52 and 54 of mounting member 16.

In particular, sensor devices 17A and 17B are positioned near the second recess 24 in proximity to the upper and lower portions 52 and 54 of the mounting member 16 and are capable of detecting a corresponding identification member 56 attached to portions 52 and 54, respectively. Accordingly, sensor device 17A is placed in a position to detect an identification member 56 attached to only on upper portion 52 of mounting member 16, while sensor device 17B is positioned to detect the presence of an identification member 56 attached only to the lower portion 54 of mounting member 16. As noted above, the present invention contemplates that a corresponding sensor device 17 is provided for each additional portion of mounting member 16 adapted to receive an identification member 56.

As further noted above, software subsystem 15 provides a means for allowing the flow control apparatus 12 to identify the functional configuration of administration feeding set 10 loaded to flow control apparatus 12. FIG. 18 illustrates the sequence of steps software subsystem 15 executes through microprocessor 37 to identify a functional configuration of administration feeding set 10 loaded to flow control apparatus 12 from a plurality of functional configurations. At decision point 318, software subsystem 15 determines whether or not an administration feeding set 10 is loaded to flow control apparatus 12. If the administration feeding set 10 is not loaded, then at step 324 the flow control apparatus 12 remains inoperative. However, if the administration feeding set 10 is loaded to flow control apparatus 12, the administration feeding set 10 and flow control apparatus are ready for operation once software subsystem 15 then identifies the functional configuration of administration feeding set 10 being loaded to flow control apparatus 12.

When engagement of mounting member 16 is detected at decision point 318, microprocessor 37 directs the flow control apparatus 12 to display an indication of such engagement to the user. At step 320, software subsystem 15 determines what functional configuration of administration feeding set 10 is loaded to the flow control apparatus 12 and ready for operation.

In order to identify the functional configuration of administration feeding set 10, software subsystem 15 executes a series of decision points 322, 326, and 328. At each of these decision points software subsystem 15 compares the number and placement of identification member 56 detected by sensor 17 with data stored in database 134.

At decision point 322, if sensor 17 detects an identification member 56 attached to both the upper and lower portions 52, 54 of mounting member 16, software subsystem 15 identifies the administration feeding set 10 as having a flushing configuration. However, if an identification member 56 is not detected at both the upper and lower portions 52, 54 then software subsystem 15 proceeds to decision point 326. At decision point 326, if sensor 17 detects an identification member 56 attached to only lower portion 54 information retrieved from database 134 identifies the administration feeding set 10

as having a re-certification configuration. However, if sensor 17 detects an identification member 56 attached only to the upper portion 52 of mounting member 16 at step 328, then software subsystem 15 determines that the administration feeding set 10 loaded to flow control apparatus 12 has a feeding configuration.

Once software subsystem 15 identifies the functional configuration of administration feeding set 120 loaded to flow control apparatus 12, microprocessor 37 directs that this information be displayed on user interface 40. Thus, software subsystem 15 is able to not only detect that the administration feeding set 10 is loaded, but also determine and display the functional configuration of the administration feeding set 10, such as feeding, flushing or re-certification loaded to the flow control apparatus 12. However, the present invention contemplates that alternate arrangements for placement of an identification member 56 attached to upper and lower portions 52, 54 may correspond to different functional configurations for administration feeding set 10.

In an alternative identification scheme shown in FIG. 16, an identification member 56 may be attached to three different portions of a mounting member 16A, which increases the total number of functional configurations capable of being detected by the sensor 17 from three to seven configurations. The present invention further contemplates that increasing the number of portions on mounting member 16A for engaging an identification member 56 increases the number of different functional configurations for administration feeding set 10 that can be detected and identified by flow control apparatus 12. Preferably, the software subsystem 15 utilizes the following equation to determine the number of functional configurations for mounting member 16:

$$X-2^n-1$$

Wherein X is the number of potential different functional configurations and n is the number of receiving portions along mounting member 16.

Preferably, mounting member 16A may be a concentric sleeve having at least three separate receiving portions co-axial with the fluid pathway 61, and with each portion adapted to receive an identification member 56 according to one or more identification schemes. In this alternative embodiment, mounting member 16A preferably has a middle receiving portion 58 in addition to the upper and lower portions 52, 54 that are each adapted to receive an identification member 56. Additionally, to further increase the number of possible identification schemes the polarity on any number of identification members 56 may be reversed using techniques known in the art in order to provide another means of detecting one or more identification members 56 attached to mounting member 16.

It should be understood from the foregoing that, while particular embodiments of the invention have been illustrated and described, various modifications can be made thereto without departing from the spirit and scope of the invention as will be apparent to those skilled in the art.

What is claimed is:

1. An administration feeding set in combination with a flow control apparatus to deliver fluid from at least one fluid source to a patient, the flow control apparatus comprising a recess, upper and lower sensing devices near the recess for detecting magnetic components or magnetically-susceptible metallic components, and a microprocessor operatively associated with a software subsystem;

the administration feeding set comprising:

tubing for flow of fluid along a fluid pathway;

a mounting member on the tubing receivable in the recess of said flow control apparatus, said mounting member having upper and lower receiving portions co-axial with said fluid pathway, each receiving portion being adapted to receive an identification member; and

one or more identification members selectively positioned on one or both of said upper and lower receiving portions of the mounting member, each identification member comprising a magnetic component or a magnetically-susceptible metallic component;

the arrangement being such that when the administration set is loaded on the flow control apparatus with the mounting member properly positioned in said recess, the upper and lower sensing devices are positioned for detecting any identification members on the receiving portions of the mounting member to permit identification of the administration feeding set as having a particular functional configuration different from another functional configuration;

wherein said software system identifies said functional configuration based on said positioning of said one or more identification members as sensed by said upper and lower sensing devices.

2. The combination set as set forth in claim 1 wherein a first identification member is mounted on one of said receiving portions and a second identification member is mounted on another of said receiving portions.

3. The combination set forth in claim 1 wherein said fluid pathway extends through the mounting member from one end of the mounting member to an opposite end of the mounting member.

4. The combination set forth in claim 3 wherein said tubing comprises a first tubing connected to said upper receiving portions and a second tubing connected to said lower receiving portion.

5. The combination set forth in claim 1 wherein said fluid pathway extends through the mounting member, and wherein each of said receiving portions of the mounting member surrounds said fluid pathway.

6. The combination set forth in claim 5 wherein said tubing comprises a first tubing connected to a said upper receiving portions and a second tubing connected to said lower receiving portions.

7. The combination set forth in claim 6 wherein said first tubing is stretchable and adapted to stretch when the administration feeding set is installed on said flow control apparatus.

8. The combination set forth in claim 1 wherein said mounting member comprises a third co-axial receiving portion adapted to receive an identification member.

9. The combination set forth in claim 8 wherein a first identification member is mounted on said upper receiving portions, a second identification member is mounted on said lower receiving portions, and a third identification member is mounted on a third of said third receiving portion.

10. The combination set forth in claim 1 wherein the administration set further comprises a valve mechanism upstream from said mounting member for control of fluid flow through said tubing, the valve mechanism being adapted to engage said flow control apparatus, and wherein said valve mechanism is movable between at least two positions including an open position permitting fluid flow and a closed position preventing fluid flow, and wherein the valve mechanism is configured such that the valve mechanism can be disengaged from the flow control apparatus when in said closed

11

position but cannot be disengaged from the flow control apparatus when in said open position.

11. The combination set forth in claim **1** wherein said particular functional configuration is a feeding configuration and said another functional configuration is one of a flushing configuration and a re-certification configuration.

12. The combination set forth in claim **1** wherein said particular functional configuration is a flushing configuration

12

and said another functional configuration is one of a feeding configuration and a re-certification configuration.

13. The combination set forth in claim **1** wherein said particular functional configuration is a re-certification configuration and said another functional configuration is one of a flushing configuration and a feeding configuration.

* * * * *