



US007749198B2

(12) **United States Patent**
Smith

(10) **Patent No.:** **US 7,749,198 B2**
(45) **Date of Patent:** **Jul. 6, 2010**

(54) **SURGICAL PORTAL APPARATUS WITH VARIABLE ADJUSTMENT**

5,411,515 A 5/1995 Haber et al.
5,417,705 A 5/1995 Haber et al.

(Continued)

(75) Inventor: **Robert C. Smith**, Middletown, CT (US)

FOREIGN PATENT DOCUMENTS

(73) Assignee: **Tyco Healthcare Group LP**, North Haven, CT (US)

EP 0716862 A 6/1996

(Continued)

(*) Notice: Subject to any disclaimer, the term of this patent is extended or adjusted under 35 U.S.C. 154(b) by 44 days.

OTHER PUBLICATIONS

(21) Appl. No.: **12/124,688**

European Search Report for corresponding application EP 08251758—date of mailing is Sep. 18, 2008 (3 pages).

(Continued)

(22) Filed: **May 21, 2008**

Primary Examiner—Nicholas D Lucchesi
Assistant Examiner—Brooke M Matney

(65) **Prior Publication Data**

US 2008/0294114 A1 Nov. 27, 2008

(57) **ABSTRACT**

Related U.S. Application Data

(60) Provisional application No. 60/931,244, filed on May 22, 2007.

A surgical portal apparatus includes a portal member defining a longitudinal axis and having a longitudinal opening there-through for receiving a surgical object, an adjustable seal disposed within the longitudinal opening and having inner seal portions adapted to permit passage of the surgical object in substantial sealed relation therewith and an adjustment member mounted within the portal member and operatively connected to the adjustable seal. The adjustment member is positioned to intersect the longitudinal passageway to engage the surgical object and move relative to the portal member to thereby cause corresponding relative displacement of the inner seal portions of the adjustable seal and facilitate passage of the surgical object through the adjustable seal. The inner seal portions of the adjustable seal are adapted for relative movement between a first generally approximated position and a second generally displaced position upon movement of the adjustment member. The inner seal portions of the adjustable seal may be dimensioned to substantially prevent passage of fluids when in the first generally approximated position. In one arrangement, the adjustable seal includes first and second seal elements which define the inner seal portions.

(51) **Int. Cl.**

A61M 5/178 (2006.01)

(52) **U.S. Cl.** **604/167.06**

(58) **Field of Classification Search** 604/167.06, 604/167.03, 246, 256, 167.01

See application file for complete search history.

(56) **References Cited**

U.S. PATENT DOCUMENTS

- 5,209,737 A * 5/1993 Ritchart et al. 604/167.03
- 5,300,035 A 4/1994 Clement
- 5,354,280 A 10/1994 Haber et al.
- 5,366,445 A 11/1994 Haber et al.
- 5,385,552 A 1/1995 Haber et al.
- 5,389,080 A 2/1995 Yoon
- 5,391,153 A 2/1995 Haber et al.
- 5,407,433 A 4/1995 Loomas

22 Claims, 6 Drawing Sheets

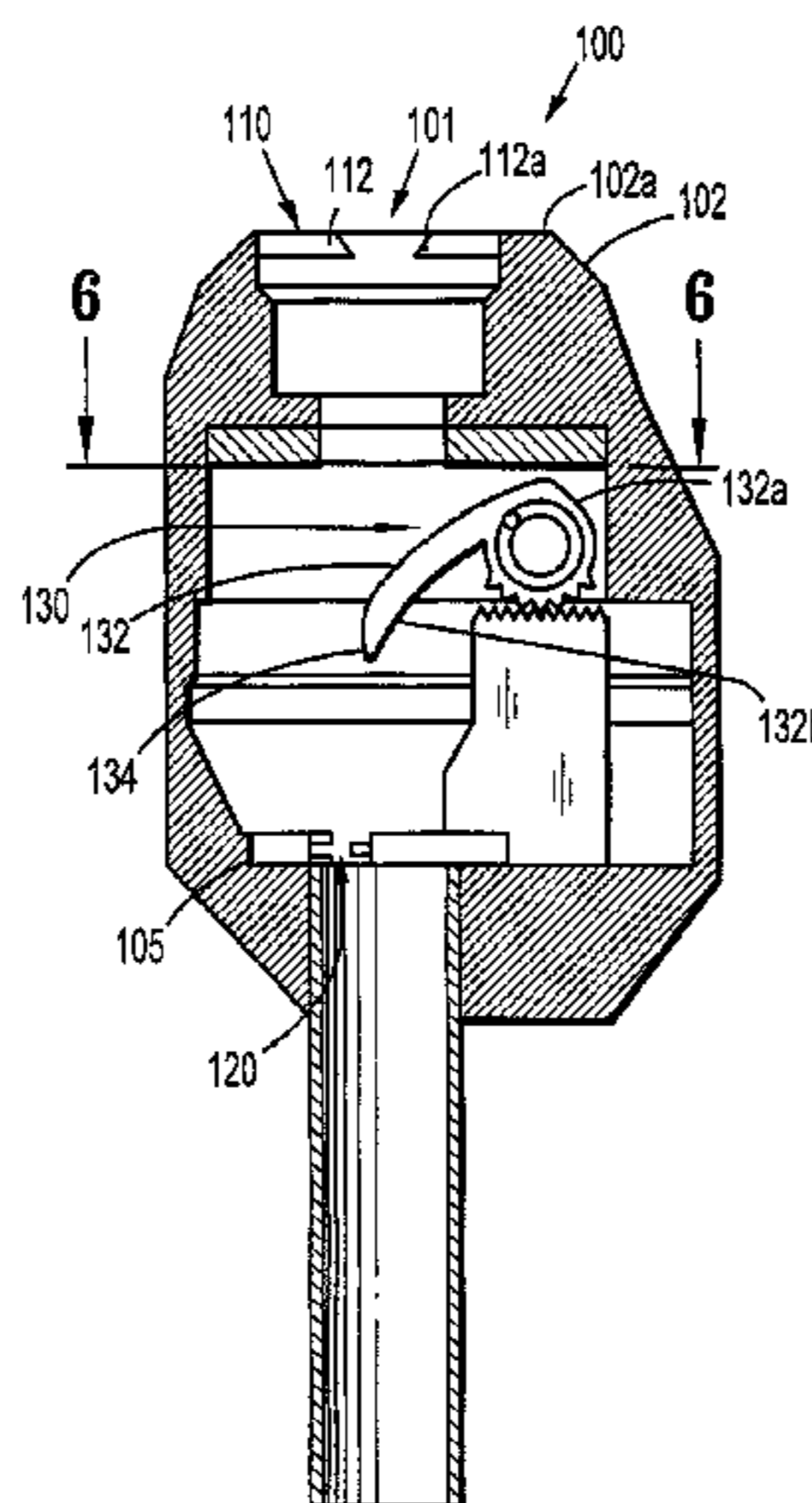

US 7,749,198 B2

Page 2

U.S. PATENT DOCUMENTS

5,429,609 A 7/1995 Yoon
5,441,486 A 8/1995 Yoon
5,484,418 A 1/1996 Quiachon et al.
5,492,304 A 2/1996 Smith et al.
5,496,280 A 3/1996 Vandenbroek et al.
5,545,142 A 8/1996 Stephens et al.
5,569,206 A 10/1996 Gorman, Jr. et al.
5,591,137 A 1/1997 Stevens
5,603,702 A 2/1997 Smith et al.
5,613,954 A 3/1997 Nelson et al.
5,628,732 A 5/1997 Antoon, Jr. et al.
5,634,908 A 6/1997 Loomas
5,657,963 A * 8/1997 Hinchliffe et al. 251/149.1
5,693,025 A 12/1997 Stevens
5,697,913 A 12/1997 Sierocuk et al.
5,709,664 A 1/1998 Vandenbroek et al.
5,720,759 A 2/1998 Green et al.
5,752,938 A 5/1998 Flatland et al.
5,788,676 A 8/1998 Yoon
5,792,113 A 8/1998 Kramer et al.
5,814,026 A 9/1998 Yoon
5,820,600 A 10/1998 Carlson et al.
5,820,604 A 10/1998 Fox et al.
5,895,377 A 4/1999 Smith et al.
5,906,595 A 5/1999 Powell et al.
5,913,847 A 6/1999 Yoon
5,935,122 A 8/1999 Fourkas et al.
5,941,852 A 8/1999 Dunlap et al.
5,989,224 A 11/1999 Exline et al.
5,989,232 A 11/1999 Yoon
5,989,233 A 11/1999 Yoon
RE36,702 E 5/2000 Green et al.
6,066,117 A 5/2000 Fox et al.
6,083,203 A 7/2000 Yoon
6,093,176 A 7/2000 Dennis
6,123,689 A 9/2000 To et al.
6,197,016 B1 3/2001 Fourkas et al.

6,482,181 B1 11/2002 Racenet et al.
6,514,260 B1 2/2003 Zdeblick et al.
6,551,282 B1 4/2003 Exline et al.
6,569,120 B1 5/2003 Green et al.
6,595,946 B1 7/2003 Pasqualucci
6,663,598 B1 12/2003 Carrillo, Jr. et al.
6,702,787 B2 3/2004 Racenet et al.
6,726,663 B1 4/2004 Dennis
6,811,546 B1 11/2004 Callas et al.
6,834,842 B2 12/2004 Houde
6,863,661 B2 3/2005 Carrillo, Jr. et al.
6,923,783 B2 8/2005 Pasqualucci
6,942,671 B1 9/2005 Smith
6,981,966 B2 1/2006 Green et al.
7,011,314 B2 3/2006 McFarlane
7,025,747 B2 4/2006 Smith
7,083,626 B2 8/2006 Hart et al.
7,101,353 B2 9/2006 Lui et al.
7,112,185 B2 9/2006 Hart et al.
7,153,319 B1 12/2006 Haberland et al.
7,169,130 B2 1/2007 Exline et al.
7,179,263 B2 2/2007 Zdeblick et al.
7,235,062 B2 6/2007 Brustad
7,244,244 B2 7/2007 Racenet et al.
7,276,075 B1 10/2007 Callas et al.
7,390,317 B2 6/2008 Taylor et al.

FOREIGN PATENT DOCUMENTS

EP 1671596 A 6/2006
GB 2298906 A 9/1996
WO WO93/01850 A 2/1993
WO WO94/07552 A 4/1994
WO WO01/89397 A 11/2001

OTHER PUBLICATIONS

US 7,282,043, 10/2007, Racenet et al. (withdrawn)

* cited by examiner

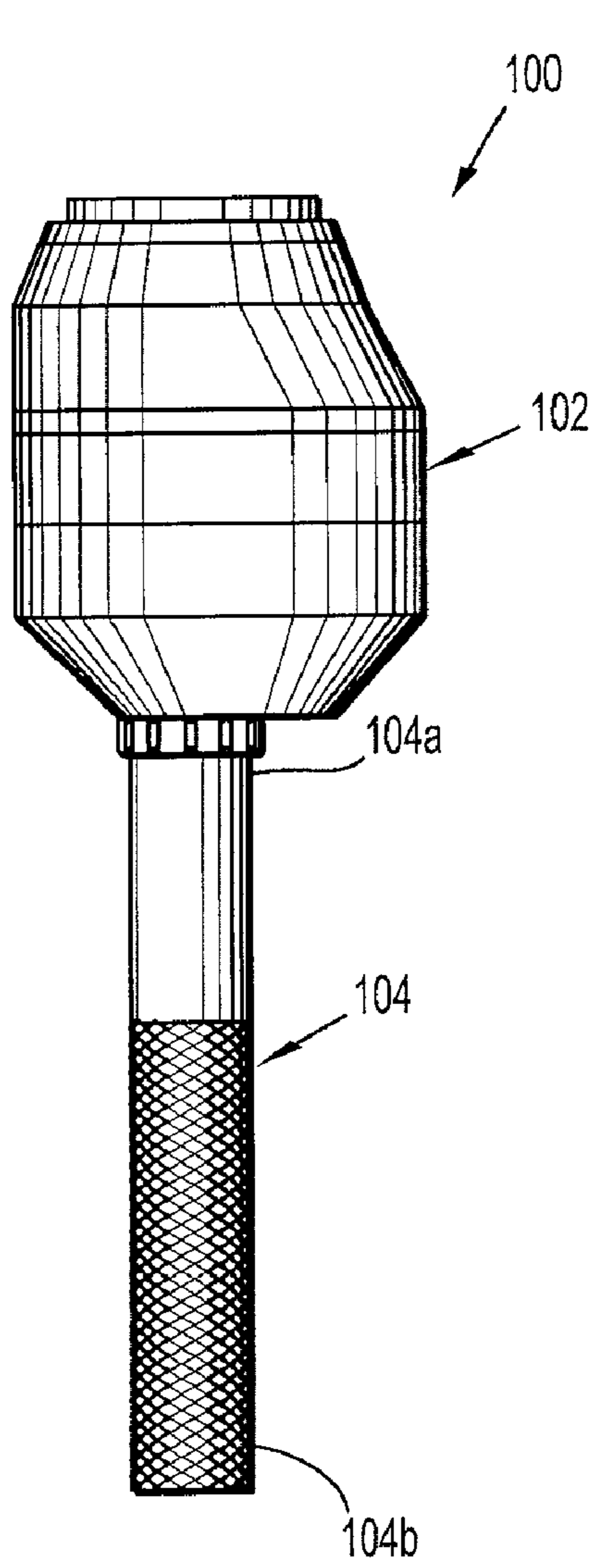

FIG. 1

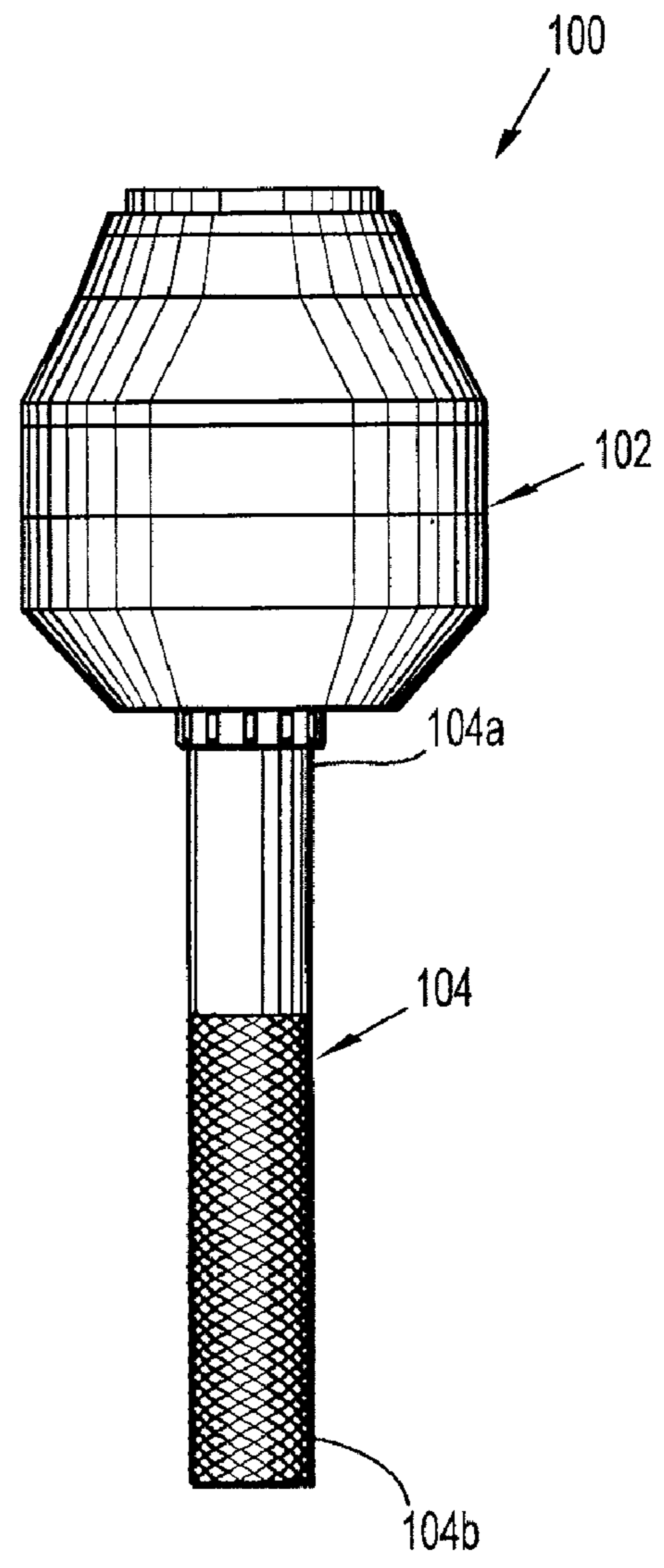

FIG. 2

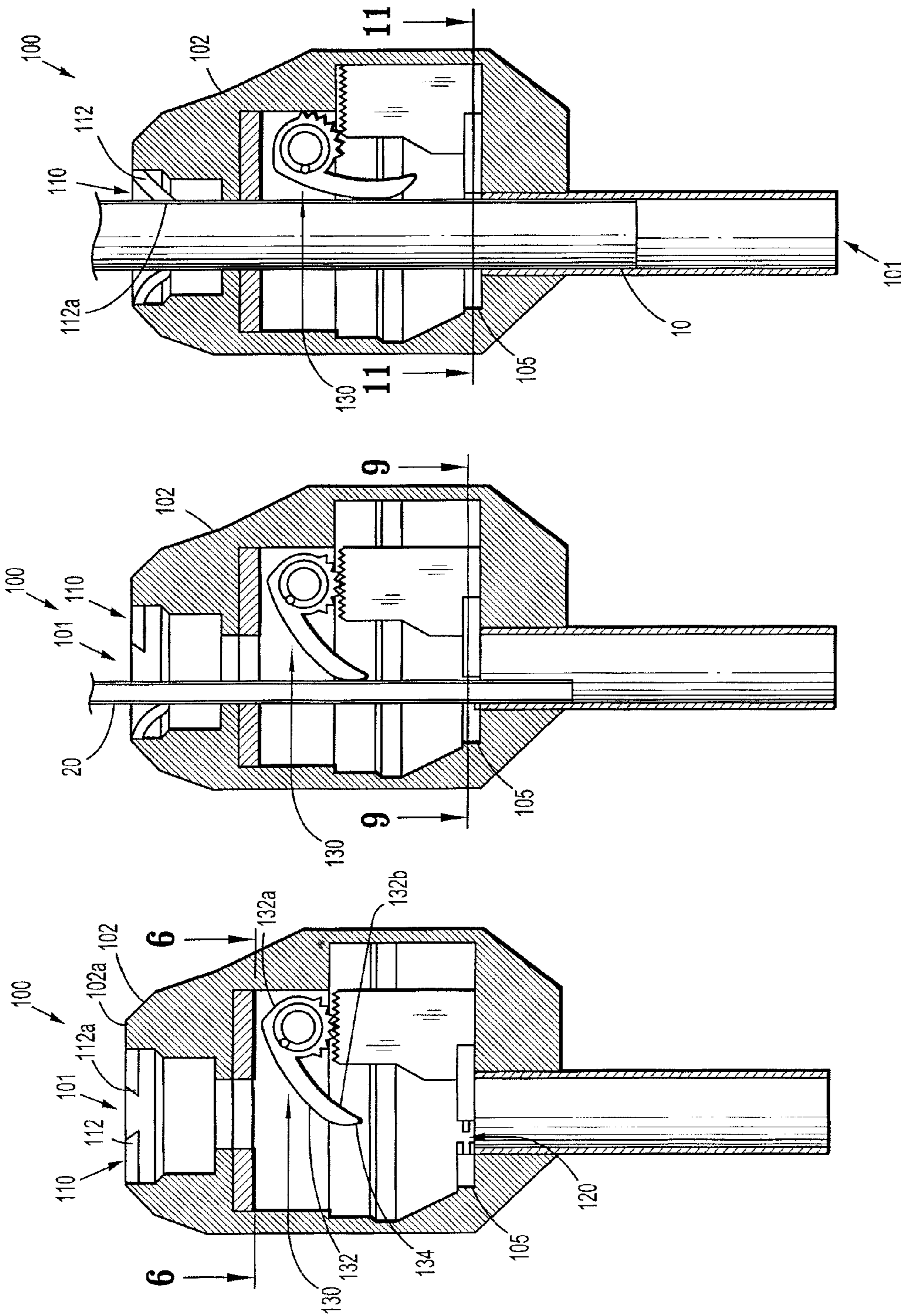

FIG. 5

FIG. 4

FIG. 3

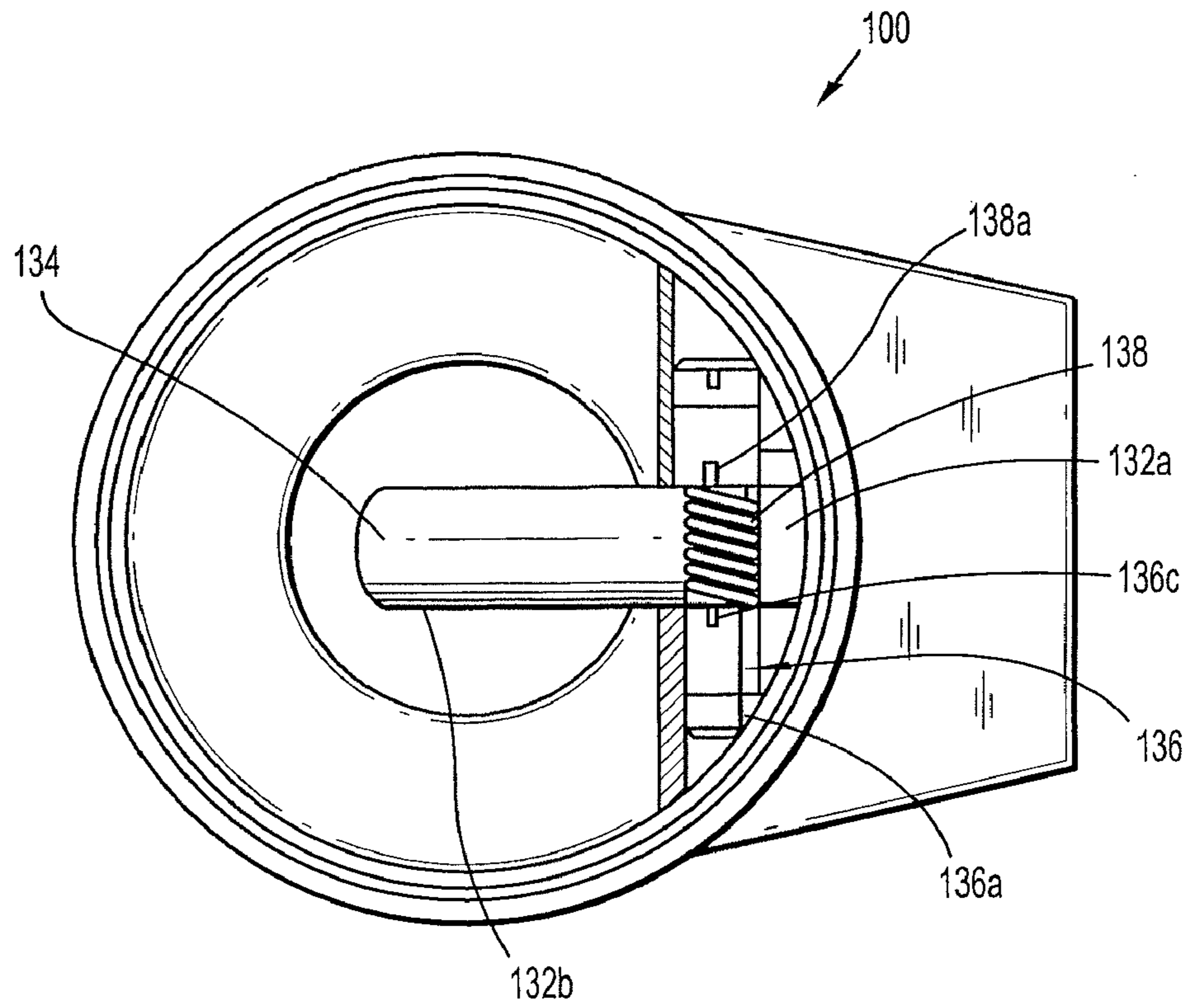

FIG. 6

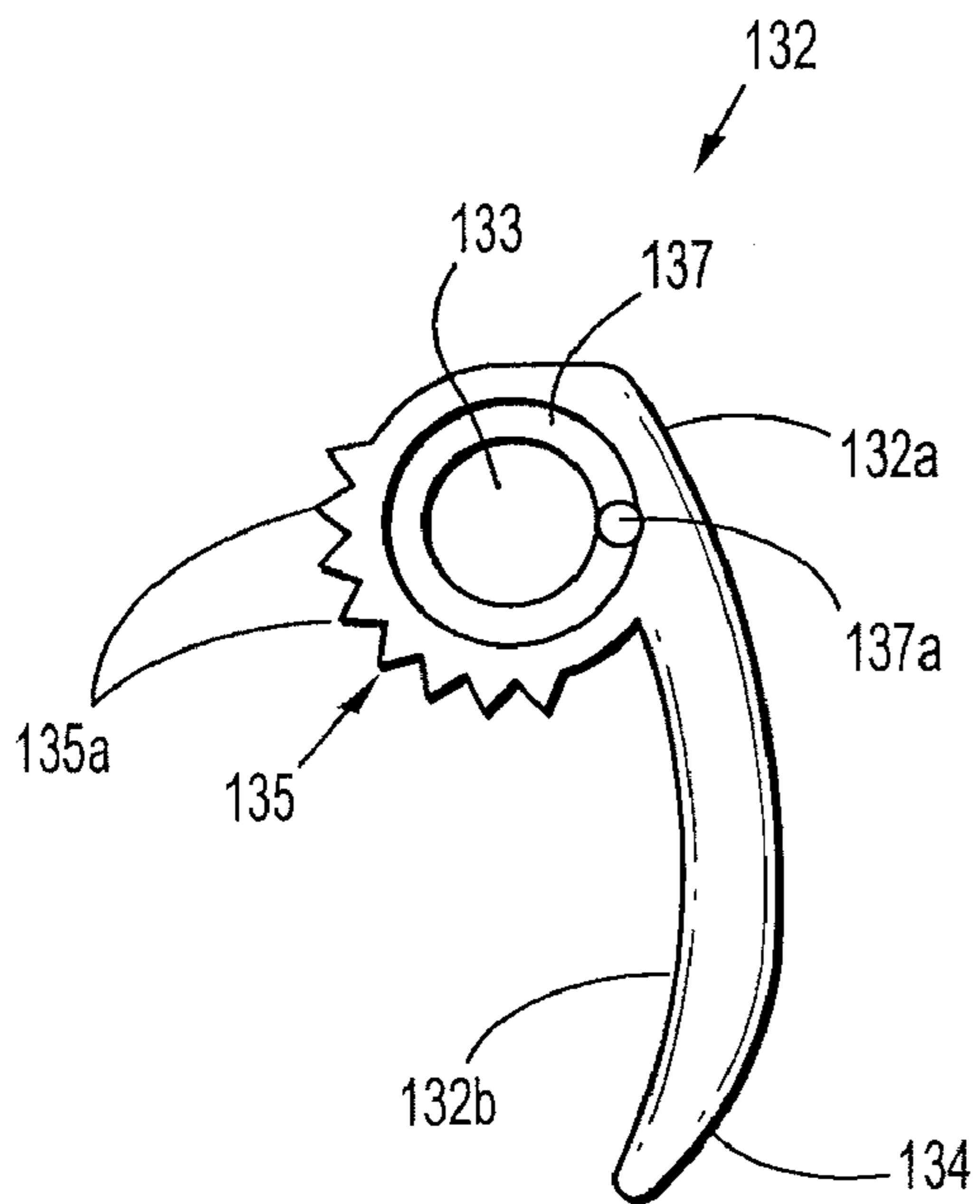

FIG. 7A

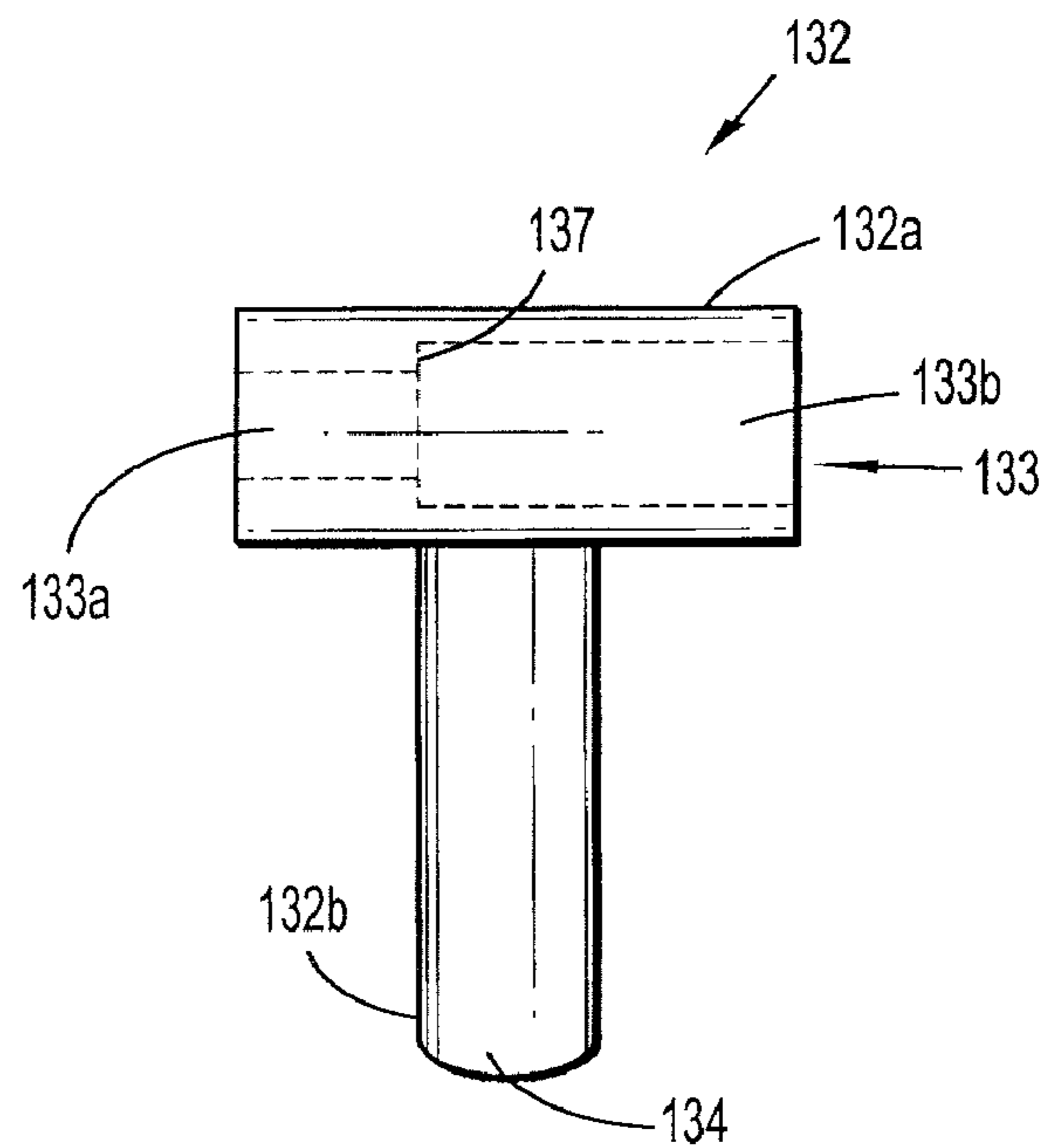

FIG. 7B

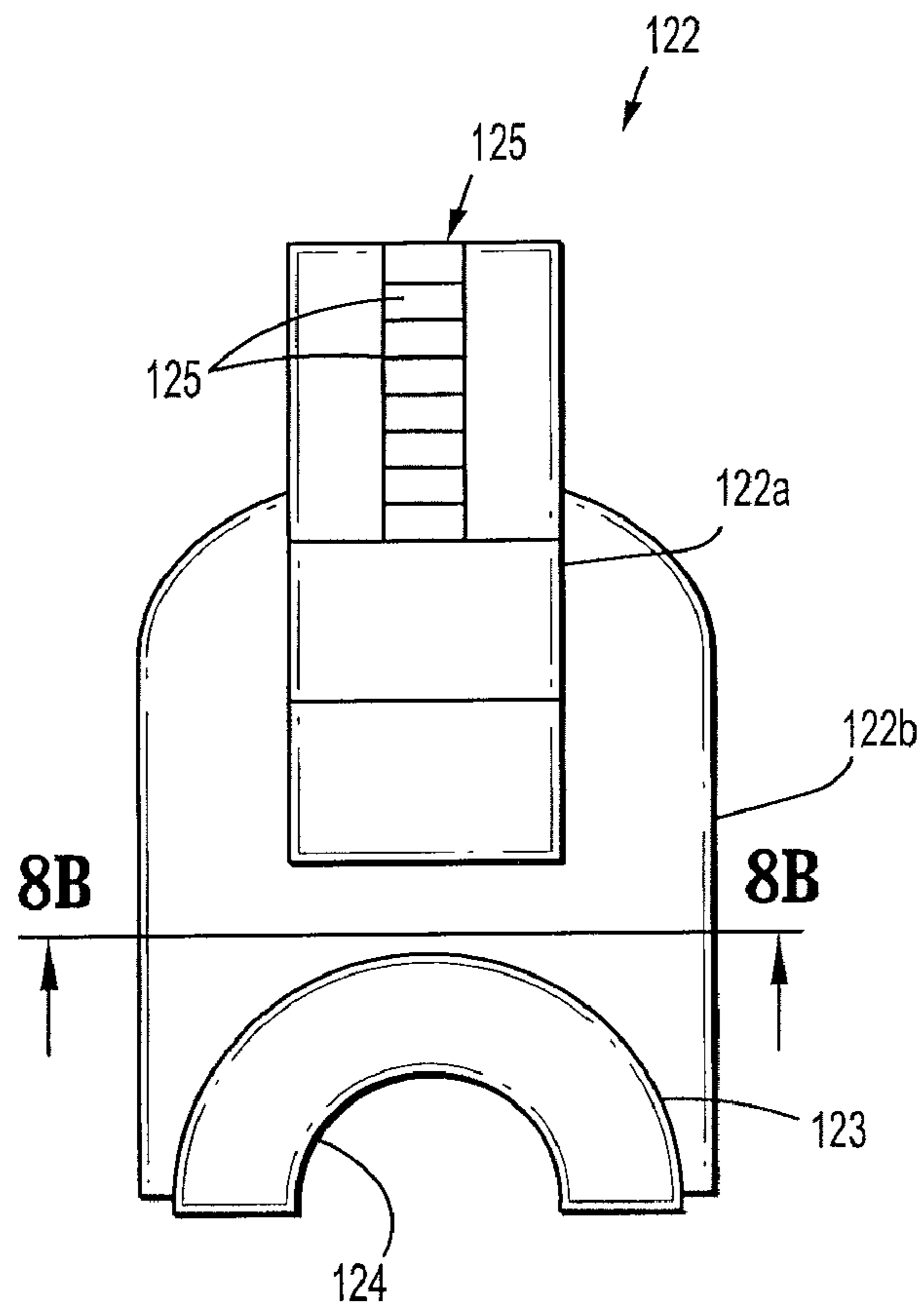

FIG. 8A

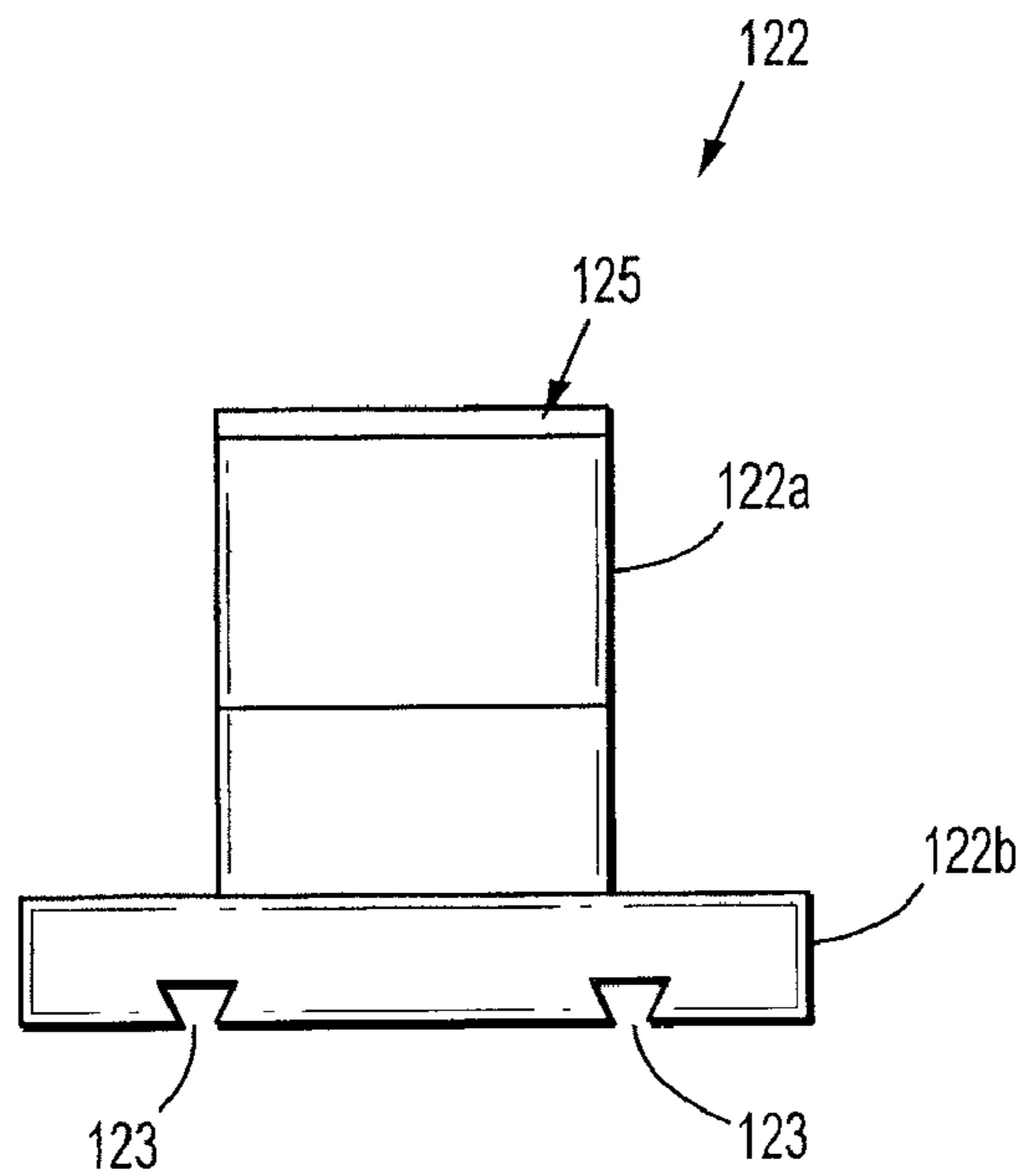

FIG. 8B

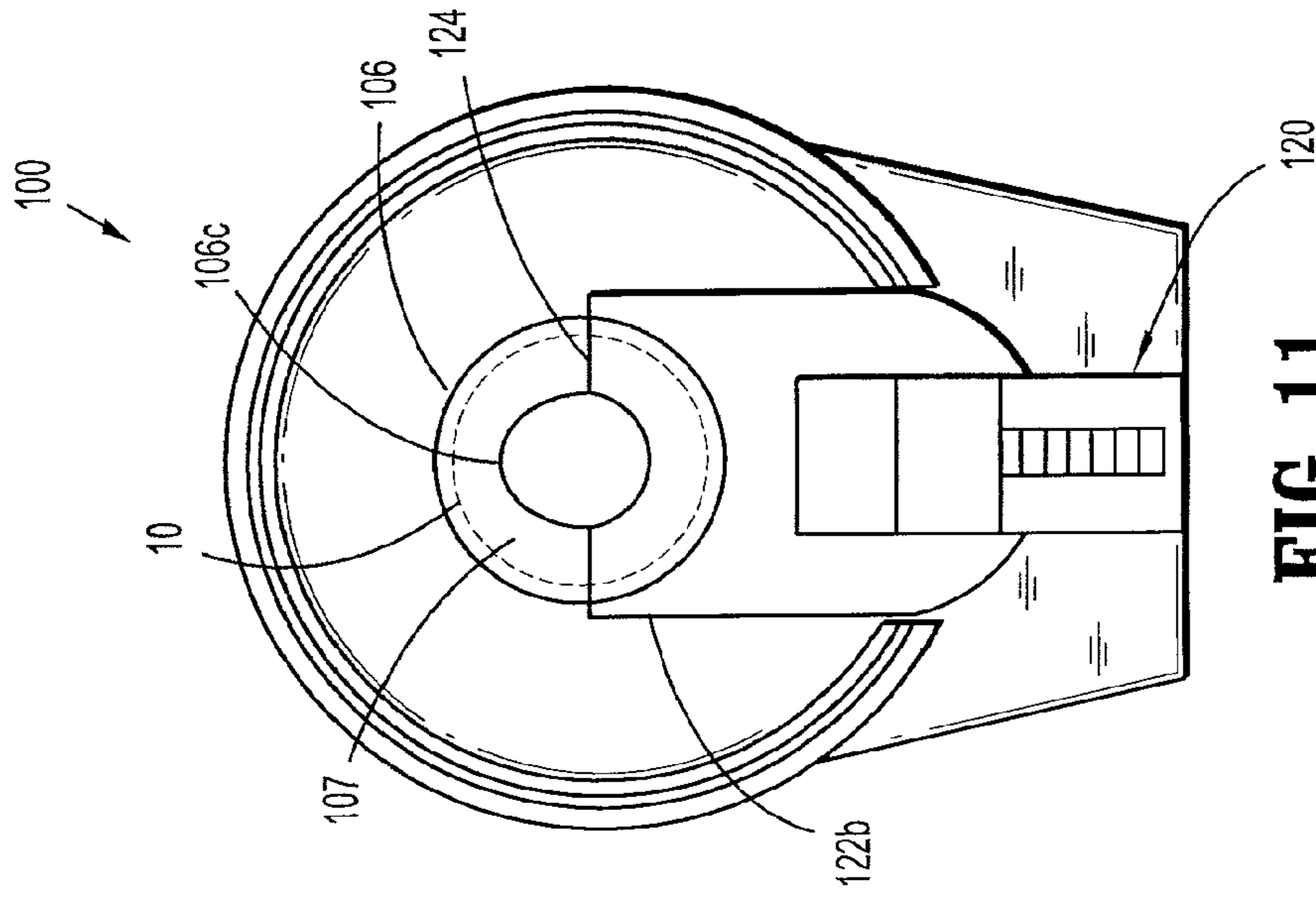

FIG. 9

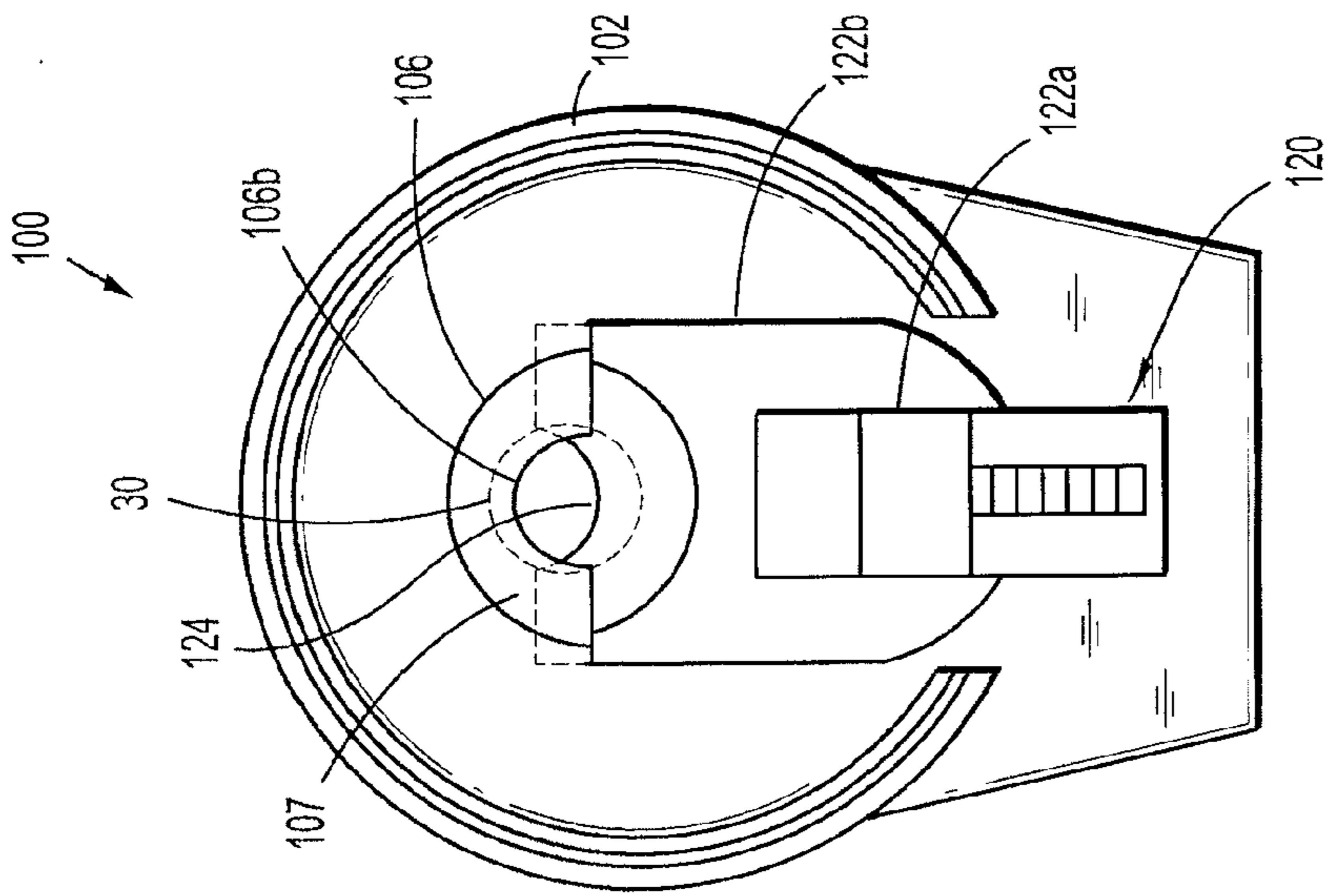

FIG. 10

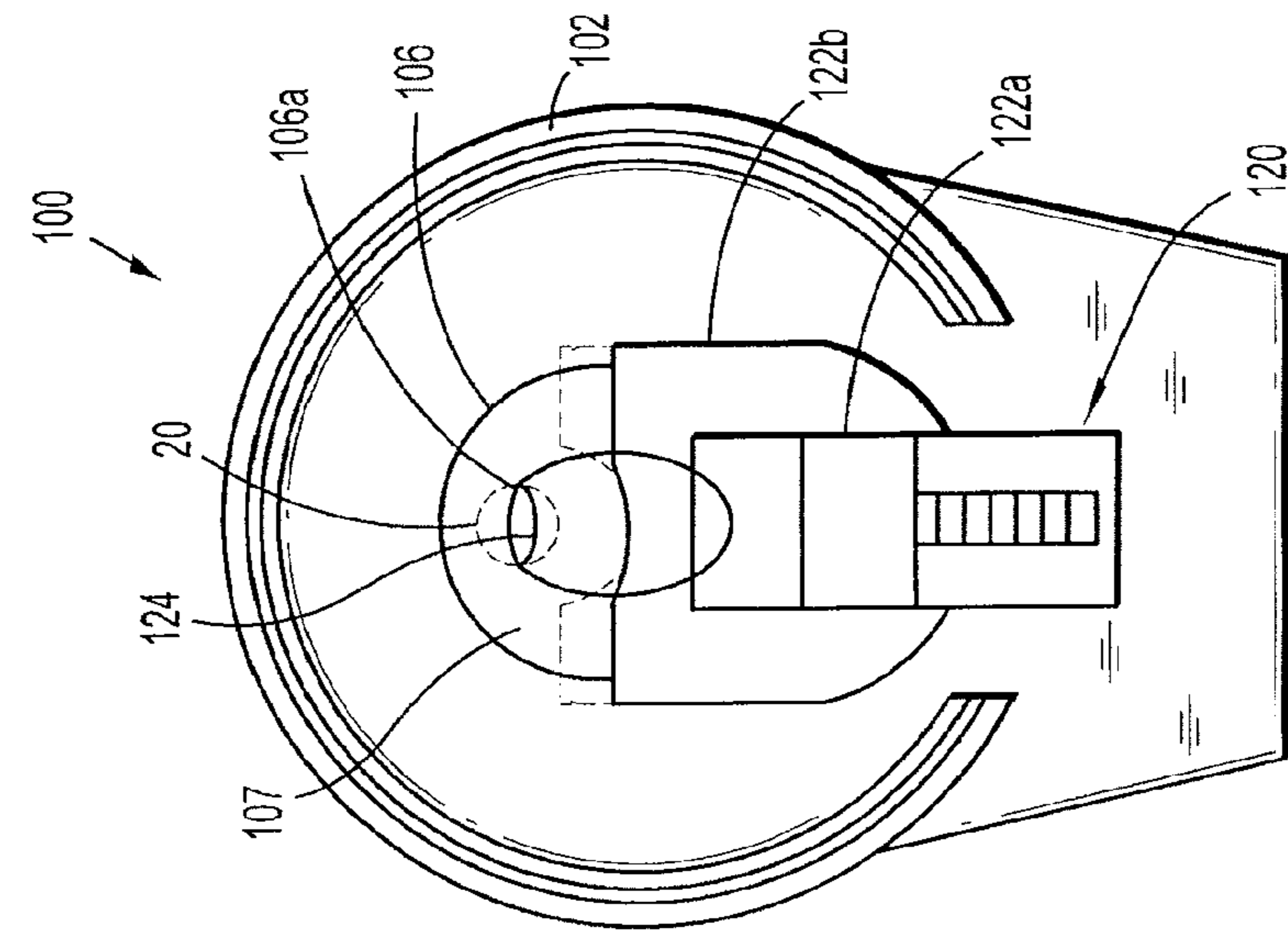

FIG. 11

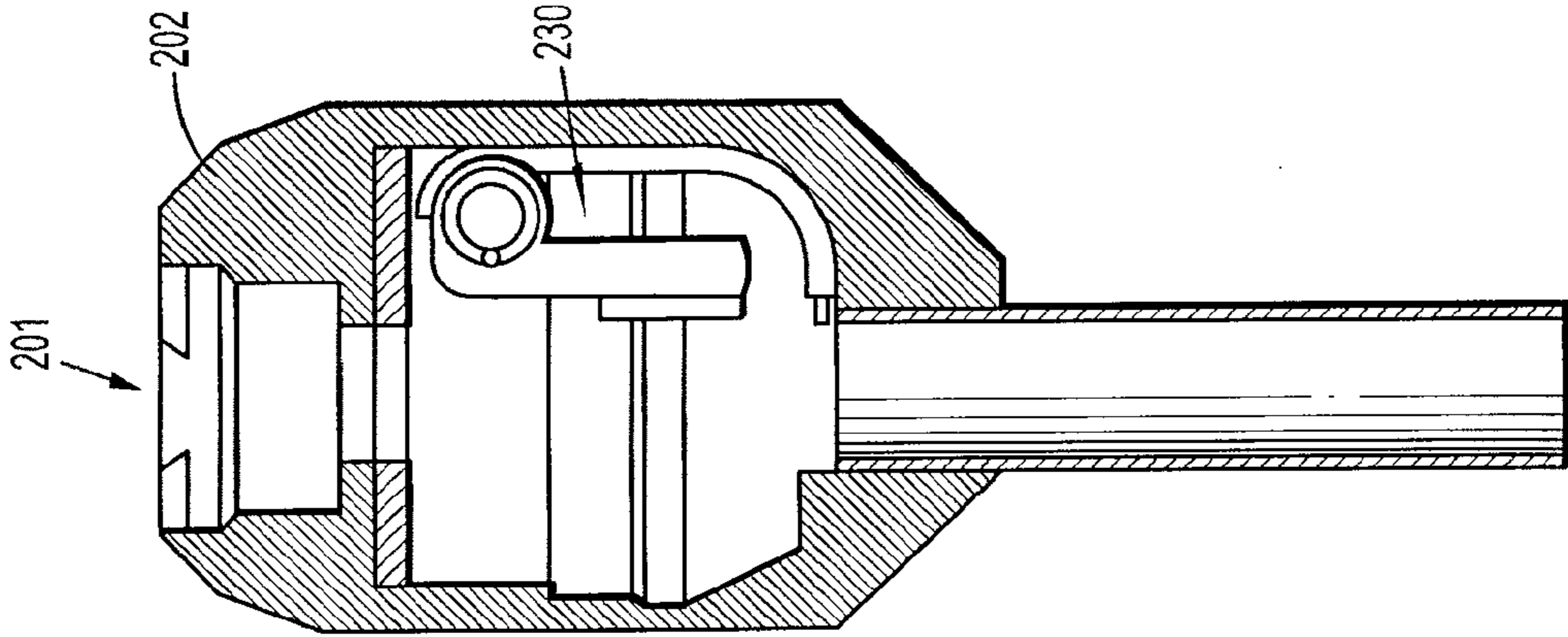

FIG. 12

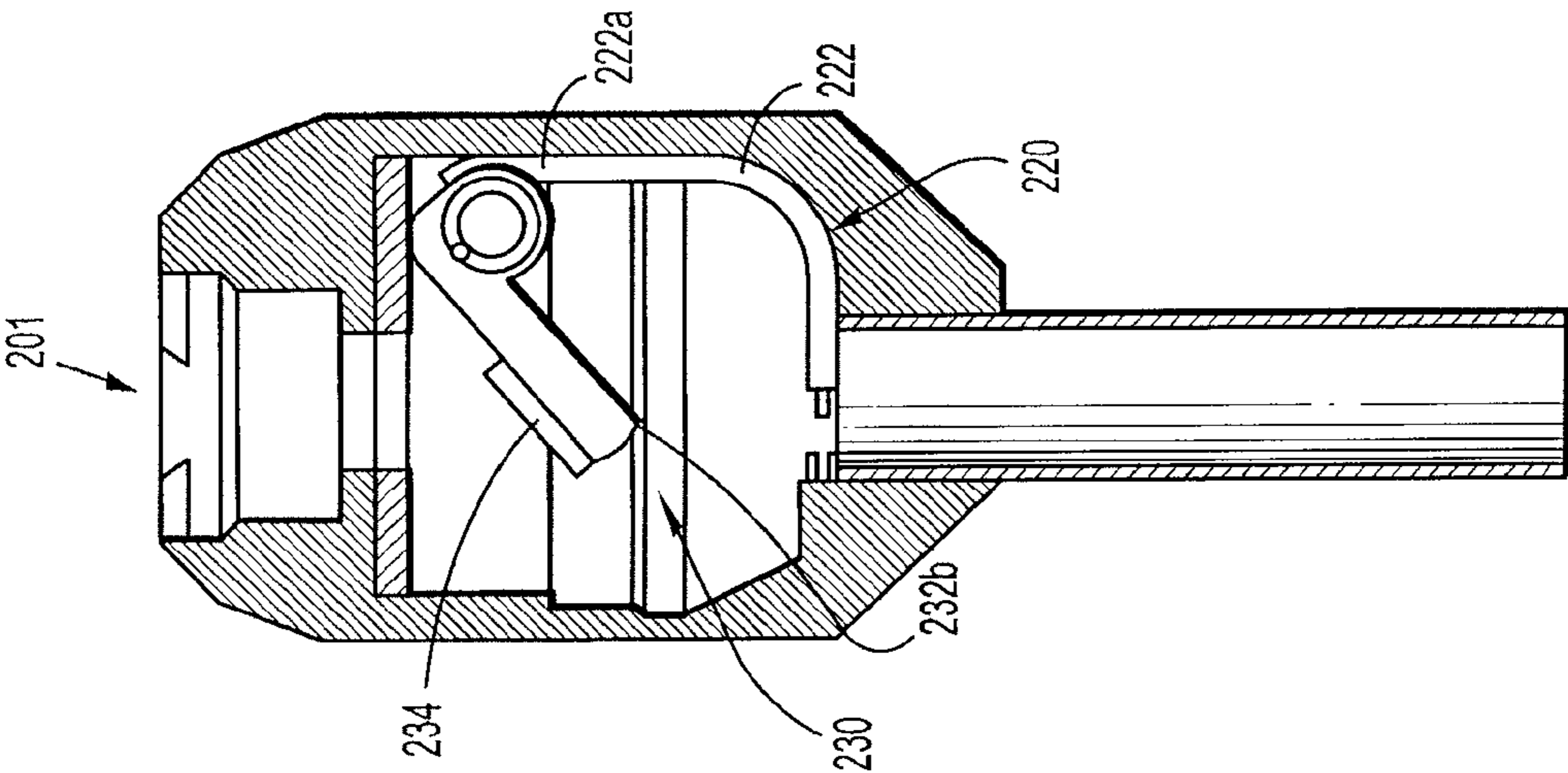

FIG. 13

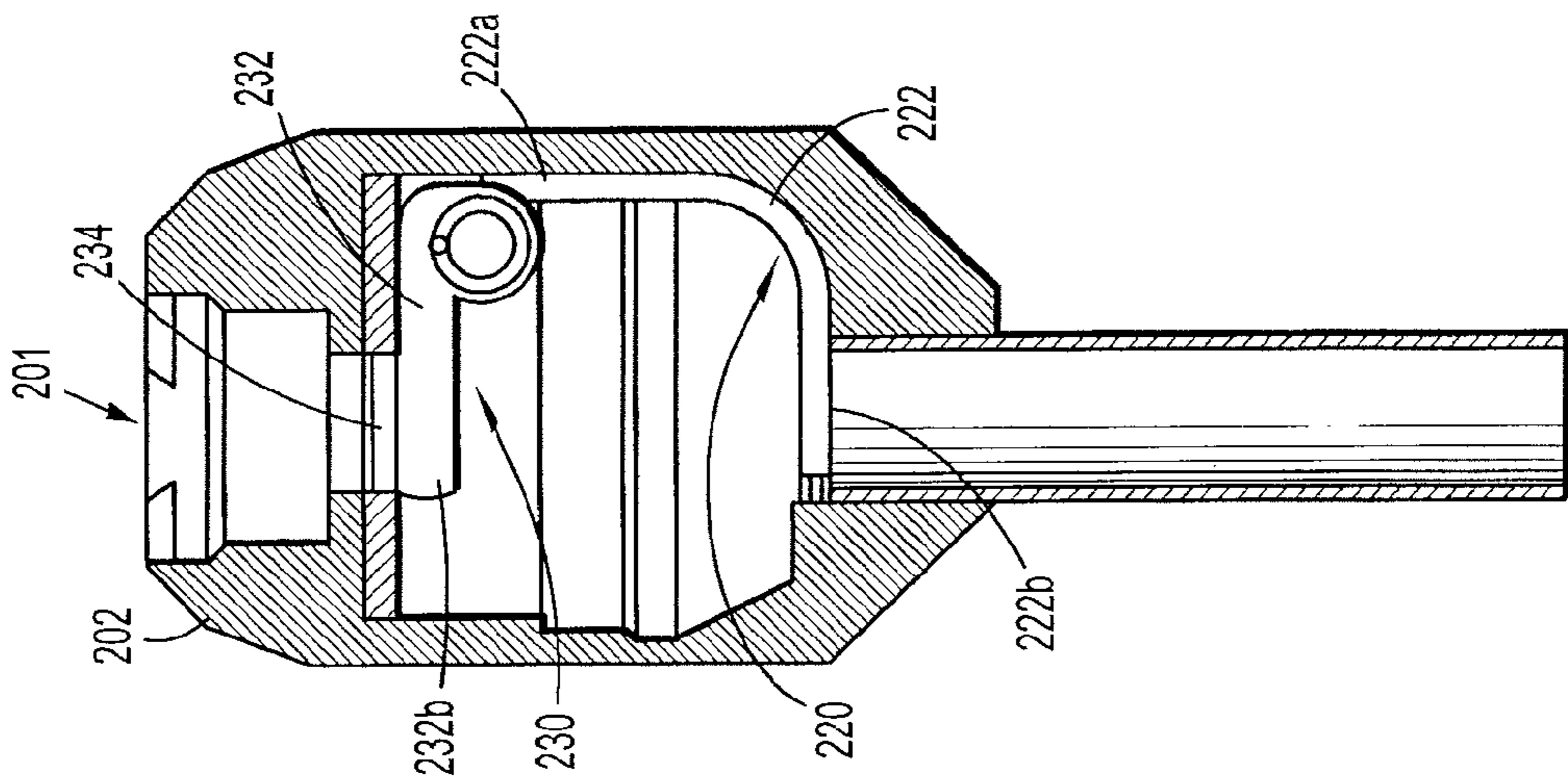

FIG. 14

1

SURGICAL PORTAL APPARATUS WITH VARIABLE ADJUSTMENT

CROSS REFERENCE TO RELATED APPLICATION

The present application claims the benefit of and priority to U.S. Provisional Application Ser. No. 60/931,244 filed on May 22, 2007, the entire contents of which are incorporated herein by reference.

BACKGROUND

1. Technical Field

The present disclosure relates generally to a surgical portal apparatus for accessing the body, and more particularly, relates to a surgical portal apparatus having variable seal adjustment capabilities for receiving endoscopic instruments of various diameters.

2. Background of Related Art

Trocar assemblies and other surgical portal apparatuses are used by surgeons to operate on a patient without having to create large incisions that may become infected and may cause major scarring. Portal apparatuses are known in the art, as are the instruments inserted therethrough for operating within the body cavity. Typically a surgical portal apparatus comprises two major components, a trocar sleeve including a housing and a cannula, and an obturator.

Accessing the body cavity using a surgical portal apparatus is a multi-step process. An incision is initially made in the skin using a scalpel or other cutting instrument. Some trocar assemblies may include a cutting blade or sharpened distal end for performing this function. The obturator, having been inserted into the sleeve of the trocar cannula, is directed through the incision in the skin. The obturator is then used to penetrate the skin and access the body cavity. By applying pressure against the proximal end of the obturator, the sharpened point of the obturator is forced through the skin until it enters the body cavity. The cannula is inserted through the perforation made by the obturator and the obturator is withdrawn, leaving the cannula as an access way to the body cavity.

In order to provide a greater space in which a surgeon may operate and to increase visibility of the tissue being operated on, the body cavity is generally insufflated. To avoid gas leakage from within the cavity prior to or during insertion of an instrument through the cannula, and as instruments are being removed and replaced, various seal members have been developed. Conventional access systems generally include one or more seals configured for use with endoscopic instruments of the same or similar diameters. In this manner, the instruments inserted through the system must be of substantially similar diameter; otherwise a proper seal will not form between the instrument and the housing. An improper seal may result in leakage of insufflation gas.

However, not all endoscopic instruments have similar diameters. An instrument for performing a procedure may have a different diameter from a second instrument for performing the same procedure, just as instruments for performing various procedures may also have different diameters. Successful completion of a procedure may require the use of various instruments throughout the procedure. Thus, completing a procedure using multiple endoscopic instruments may require the use of multiple access systems, wherein system is configured for receiving an instrument of different diameter.

2

Therefore, it would be beneficial to have a surgical portal apparatus that is configured to sealingly receive endoscopic instruments of different diameters.

SUMMARY

Accordingly, a surgical portal apparatus includes a portal member defining a longitudinal axis and having a longitudinal opening therethrough for receiving a surgical object, an adjustable seal disposed within the longitudinal opening and having inner seal portions adapted to permit passage of the surgical object in substantial sealed relation therewith and an adjustment member mounted within the portal member and operatively connected to the adjustable seal. The adjustment member is positioned to intersect the longitudinal passage-way to engage the surgical object and move relative to the portal member to thereby cause corresponding relative displacement of the inner seal portions of the adjustable seal and facilitate passage of the surgical object through the adjustable seal. The inner seal portions of the adjustable seal are adapted for relative movement between a first generally approximated position and a second generally displaced position upon movement of the adjustment member. The inner seal portions of the adjustable seal may be dimensioned to substantially prevent passage of fluids when in the first generally approximated position. In one arrangement, the adjustable seal includes first and second seal elements which define the inner seal portions.

The adjustment member may be operatively connected to the first seal element, whereby movement of the adjustment member upon engagement with the surgical object causes corresponding movement of the first seal element. The first seal element may be adapted for lateral movement relative to the longitudinal axis during movement between the first generally approximated position and the second generally displaced position. The adjustment member may be adapted for pivotal movement relative to the portal member. A gear member may be operatively connected to the adjustment member and to the first seal element. The gear member is adapted to translate movement of the adjustment member to corresponding movement of the first seal element.

The adjustment member may be adapted for movement between an initial position and an activated position. The initial position and the activated position correspond to the first generally approximated position and the second generally displaced position of the inner portions of the adjustable seal. The adjustment member includes a zero closure seal adapted to substantially close the longitudinal opening when in the first position of the adjustment member.

A secondary seal may be mounted to the portal member. The adjustable seal may be adapted to form a substantial seal about a surgical object having a first cross-sectional dimension and the secondary seal is adapted to form a substantial seal about a surgical object having a second cross-sectional dimension. The second cross-sectional dimension is greater than the first cross-sectional dimension. The adjustable seal may be adapted to form a seal about a surgical object having a diameter ranging from about 4 mm to about 6 mm, and wherein the secondary seal member is adapted to form a seal about a surgical object having a diameter ranging from about 9 mm to about 13 mm. The adjustable seal may be mounted distal to the secondary seal member.

The portal member may include a portal housing and a portal sleeve extending from the portal housing.

BRIEF DESCRIPTION OF THE DRAWINGS

The foregoing summary, as well as the following detailed description will be better understood when read in conjunction with the appended figures. For the purpose of illustrating the present disclosure, various embodiments are shown. It is understood, however, that the present disclosure is not limited to the precise arrangement and instrumentalities shown.

FIG. 1 is a side perspective view of a surgical portal apparatus according an embodiment of the present disclosure;

FIG. 2 is a front perspective view of the surgical portal apparatus of FIG. 1;

FIG. 3 is a side cross-sectional view of the surgical portal apparatus of FIGS. 1 and 2 illustrating the adjustment member, gear mechanism and the seal member with the adjustment member, in a first or initial condition;

FIG. 4 is a side cross-sectional view similar to the view of FIG. 3 illustrating an endoscopic instrument having a small diameter inserted therethrough;

FIG. 5 is a side cross-sectional view of the surgical portal apparatus illustrating the adjustment member in a second condition up insertion of an endoscopic device having a large diameter;

FIG. 6 is a view illustrating the adjustment member within the housing;

FIG. 7A is a side view of the adjustment member;

FIG. 7B is a top view of the adjustment member;

FIG. 8A is a top view of the second seal member;

FIG. 8B is a side view of the second seal member;

FIG. 9 is a view illustrating the adjustment member in the initial condition;

FIG. 10 is a view illustrating the adjustment member in an intermediate position;

FIG. 11 is a view of the adjustment member in an activated position; and

FIGS. 12-14 are cross-sectional views of a surgical portal apparatus according to another embodiment of the present disclosure, in a first or sealed condition (FIG. 12), in an intermediary condition (FIG. 13), and in an open condition (FIG. 14).

DESCRIPTION OF PREFERRED EMBODIMENTS

Referring now to the drawings wherein like reference numerals illustrate similar components throughout the several views, there is illustrated the surgical portal apparatus 100 in accordance with the principles of the present disclosure. As shown in the drawings and as described throughout the following description, as is traditional when referring to relative positioning on an object, the term "proximal" refers to the end of the apparatus which is closer to the user and the term "distal" refers to the end of the apparatus which is further from the user.

Referring initially to FIGS. 1 and 2, surgical portal apparatus 100 is shown in the form of a cannula assembly. Surgical portal apparatus 100 includes a housing or portal member 102 and a cannula sleeve 104 extending distally from housing 102. Surgical portal apparatus 100 may be configured for use with any known endoscopic or laparoscopic instrument. Cannula sleeve 104 is configured to be inserted through the skin into a body cavity with the aid of an obturator (not shown). Cannula sleeve 104 may instead include a blade or piercing tip for penetrating through the skin and into a body cavity. Cannula sleeve 104 may be integral formed with housing 102.

Alternatively, cannula sleeve 104 may be configured for selectable engagement with housing 102.

Cannula sleeve 104 forms a substantially tubular member having proximal and distal ends 104a, 104b. Cannula sleeve 104 may be composed of plastic, metal, polymers or the like. Cannula 104 may be disposable, or in the alternative, reusable. Cannula sleeve 104 may be solid, or alternatively, cannula sleeve 104 may be flexible. Distal end 104b of cannula sleeve 104 may be open. Distal end 104b may instead be configured to include one or more seal members (not shown). Cannula sleeve 104 may be of any configuration and of any length or diameter. Thus, it is appreciated that the embodiments of the present disclosure are not limited by the configuration of cannula sleeve 104 and may be configured for use with any conceivable cannula assembly configuration.

Referring now to FIGS. 3-5, housing 102 of surgical portal apparatus 100 defines a passageway 101 therethrough configured for receiving endoscopic instruments of various diameters. Housing 102 includes a first seal member 110, a second seal member 120 and an adjustment member 130 therebetween. As will be described below, adjustment member 130 is operably connected to second seal member 120 such that movement of adjustment member 130 causes movement of second seal member 120.

First seal member 110 extends about an inner surface of housing 102, preferably about a proximal end 102a of housing 102. However, it is envisioned that first seal member 110 may be disposed anywhere along the length of passageway 101. First seal member 110 may comprise any known seal configurations. First seal member 110 may include one or more seal surfaces 112. First seal member 110 is configured for sealably receiving an endoscopic instrument 10 having a large diameter. Seal surface 112 may be formed of rubber, plastic, polymer or the like. An instrument contacting end 112a of seal surface 112 may be tapered to facilitated sealing about endoscopic instrument 10. Preferably, first seal member 110 is configured for sealably receiving an endoscopic instrument having the largest diameter capable of being inserted through passage 101.

Still referring to FIGS. 3-5, adjustment member 130 defines a substantially planar base 132. Base 132 includes a first end 132a configured for pivotal engagement with housing 102 and a second end 132b configured to be pivotally biased within passageway 101. First end 132a of base 132 defines an opening 133 therethrough for pivotally receiving a bearing pin 136 (FIG. 6). Opening 133 includes first and second portions 133a, 133b. First portion 133a of opening 133 is configured to receive a first end 136a of bearing pin 136. Second portion 133b of opening 133 is larger than first portion 133a and is configured to receive a spring 138 about a second end 136b of bearing pin 136. A shoulder 137 (FIG. 7A) may be formed between first and second portions 133a, 133b of opening 133. Shoulder 137 defines an opening 137a therein for receiving a first end 138a of spring 138. Second end (not shown) of spring 138 is received within a slot 116c formed in second end 136b of bearing pin 136. Bearing pin 136, including spring 138 received about second end 116b, is inserted through opening 133 and is securely mounted to housing 102. The configuration of spring 138 within first end 132a of base 132 causes second end 132b thereof to be biasedly received within passageway 101 formed in housing 102.

Still referring to FIG. 7A, first end 132a of base 132 further includes a geared portion 135 radially extending at least partially about opening 133. Geared portion 135 includes gears 135a. Geared portion 135 is configured to engage a geared

5

portion **125** formed in a base **122** of second seal member **120** (FIGS. **8A-8B**). In this manner, geared portion **125** of second seal member **120** forms the rack to the pinion of geared portion **135** formed on adjustment member **130**. As with all rack and pinion gears, rotational movement of the pinion gear causes lateral movement of the rack. Geared portion **135** may extend the width of first end **132a** of base **132**. Alternatively, geared portion **135** may comprise one or more rows of gears **135a** for engaging one or more rows of gears **125a** formed on first end **122a** of base **122** (FIGS. **8A** and **8B**).

Base **132** of adjustment member **130** includes a second end **132b** defining an instrument contacting surface **134**. Second end **132b** of base **132** is configured extend within passageway **101**. As will be described below, second end **132b** is configured to engage an endoscopic instrument **10**, **20** as it is inserted through passageway **101** if the diameter of the instrument is larger than the opening formed in second seal member **120**. As seen in FIGS. **4** and **5**, contacting surface **134** of second end **132b** may be rounded to prevent contact with endoscopic instrument **20** with the smaller diameter or facilitate engagement with endoscopic instrument **20** with the larger diameter.

Although as described, base **132** is biased received within passageway **101** by spring **138**, it is envisioned that base **132** may be biased with any known means including, but not limited to, a hydraulic or pneumatic piston, flexible plate or the like.

Referring now to FIGS. **8A** and **8B**, second seal member **120** includes a base **122** having a first end **122a** and a second end **122b**. First end **122a** of base **122** includes a substantially rectangular body including a geared portion **125**. Geared portion **125** includes gears **125a**. Gears **125a** of geared portion **125** are configured to selectively engage gears **135a** of geared portion **135** formed on first end **132a** of base **132**. As will be described below, geared portions **135**, **125** are configured to such that second seal members **120** is opened as base **132** of adjustment member **130** is moved. Second end **122b** of base **122** further defines one or more grooves **123** for slidably securing base **122** within housing **102**. Housing **102** may define corresponding rails or tracks (not shown) configured to be received within grooves **123** formed in base **122**.

Second end **122b** of base **122** includes a substantially planar member defining a semi-circular opening **123**. Second end **122b** is configured to be received within a slot **105** formed in housing **102** (FIGS. **3-5**). A seal surface **124** extends about opening **123**. Seal surface **124** may comprise one or more layers. Seal surface **124** may be formed from rubber, plastic, polymer or the like. As will be described in detail below, second end **122b** of base **122** is configured to operably engage slot **105** formed in housing **102** to form an adjustable opening **106a** (FIG. **9A**), **106b** (FIG. **9B**), **106c** (FIG. **9C**) for receiving endoscopic instruments of various diameters therethrough.

With reference to FIGS. **9-11**, housing **102** defines a semi-circular opening **106** corresponding to opening **123** defined by base **122** of second seal member **120**. Opening **106** includes a seal surface **107** extending thereabout for operable engagement with seal surface **124** of opening **123** to selectively form openings **106a-106c** as adjustment member **130** is activated in the manner described below. Seal surfaces **124**, **107** are configured to sealingly receive endoscopic instruments of increasing diameter as second seal member **120** is slidably withdrawn from slot **105** formed in housing **102**. Seal surfaces **124**, **107** may alternatively include a flap or other means for sealing opening **106** with or without an endoscopic instrument **10**, **20**, **30** inserted therethrough.

With reference now to FIGS. **3-5**, surgical portal apparatus **100** will be described as relates to the operation of first and second seal members **110**, **120** and adjustment member **130**.

6

Referring initially to FIGS. **3** and **4**, in a first or initial condition, base **132** of adjustment member **130** is pivotally biased within housing **102**. Base **132** is configured and positioned such that endoscopic instrument **20** (FIG. **4**) may pass through passageway **101** without engaging contacting surface **134** of second end **132a**. In this manner, although geared portion **135** formed on base **132** engages geared portion **125** formed on base **122**, base **122** remains slidably received within slot **105** formed in housing **102** even as endoscopic instrument **20** is inserted past base **132**. Endoscopic instrument **20** may incidentally contact seal surface **112** of first seal member **110**, however, no sealing action is expected from this contact. In an alternate embodiment, seal surface **112** may be configured to sealingly receive endoscopic instrument **20**.

With reference now to FIG. **9**, in this first or initial condition, opening **106a** is formed by semi-circular openings **106**, **123** formed in housing **102** and base **122**, respectively, and between seal surfaces **107**, **124**, respectively, for sealably receiving endoscopic instruments **10**, **20**, **30** therethrough. Alternatively, and as discussed above, in this first or initial condition, opening **106a** may be sealed prior to insertion of instrument **20** therethrough.

Referring now to FIG. **5**, in a second condition, base **132** of adjustment member **130** is completely pivoted from within passageway **101** by endoscopic instrument **10**. Instrument **10** is initially inserted past first seal member **110** where it is sealingly engaged by seal surface **112**. As instrument **10** engages contacting surface **134** formed on second end **132b** of base **132**, base **132** is pivoted from within passageway **101**. The pivoting of base **132** causes geared portion **135** formed on first end **132a** thereof to engage geared portion **125** formed on base **122** of second seal member **120**. As base **132** of adjustment member **130** is pivoted geared portion **135** formed thereon engages geared portion **125** formed on base **122**. The engagement of gears **125a**, **135a** caused by the pivoting of adjustment member **130** results in a corresponding lateral movement of second seal member **120**. Downward pivoting of adjustment member **130** causes retraction or opening of second seal member **120**, while upward pivoting of adjustment member **130** causes advancement or closing of second seal member **120**.

With reference to FIG. **11**, in the second condition, opening **106c** formed by semi-circular openings **106**, **123** and between seal surfaces **107**, **124**, respectively, for sealably receiving endoscopic instrument **10** therethrough. Opening **106** may be sized to receive an endoscopic instrument having a diameter of a size as small as endoscopic instrument **20** and as large as endoscopic instrument **10**. Preferably, endoscopic instruments **10**, **20**, **30** measure 5 mm-12 mm in diameter, however, the aspects of the current disclosure may be modified to accommodate endoscopic instruments of larger and/or smaller diameter.

Referring now to FIGS. **12-14**, an alternate embodiment of a surgical portal apparatus according to the present disclosure is shown generally as surgical portal apparatus **200**. Surgical portal apparatus **200** is similar to surgical portal apparatus **100** and will only be described as relates to the differences therebetween. Surgical portal apparatus **200** includes a housing or portal member **202** and a cannula sleeve **204**. Surgical portal apparatus **200** defines a passageway **201** therethrough for receiving endoscopic instruments of various diameters. A first seal member **210** is disposed about a proximal end of trocar housing **202**, an adjustment mechanism **230** is pivotally mounted within housing **202**, and a second seal member **220** is operably connected to adjustment mechanism **230**.

Still referring to FIGS. 12-14, adjustment mechanism 230 is similar to adjustment member 130. Adjustment mechanism 230 differs from adjustment member 130 in the means by which adjustment mechanism 230 is operably connected to second seal member 220. Unlike the engagement of geared portions 125, 135, as described above, adjustment mechanism 230 is configured to lockingly receive an end of second seal member 220. In this manner, as adjustment mechanism 230 is pivotally opened as described above, second seal member 220 wraps about an end of adjustment mechanism 230, thereby retracting second seal member 220 from across passageway 201 formed in surgical portal apparatus 200.

Second seal member 220 includes a substantially planar base 222. Base 222 may comprise plastic, polymer, metal or the like. Base 222 includes first end 222a and a second end 222b. First end 222a is configured to be lockingly received by adjustment mechanism 230. Second end 222b is substantially similar in size and shape to second end 122b of base 122 described above. As discussed above, second seal member 220 is operably engaged with adjustment mechanism 230 such that downward pivotal movement of adjustment mechanism 230 causes lateral movement of second seal member from across passageway 201.

Furthermore, unlike adjustment member 130, second end 232b of base 232 may be configured to provide another sealing member 230. Second end 232b of base 232 may include a seal surface 234. Unlike in the previous embodiment, base 232 is completely biased across passageway 201. In this manner, sealing surface 234 extends across and within passageway 201, thereby forming a zero closure seal and effectively sealing passageway 201. As an endoscopic instrument (not shown) is inserted through trocar housing 202, base 232 of sealing member 230 is pivoted in the manner discussed above, thereby retracting second seal member 220, and opening passageway 201 for insertion of an instrument there-through. Withdrawal of the endoscopic instrument causes sealing member 230 to return to a biased position across passageway 201 and results in the advancement of second seal member 220.

It will be understood that various modifications may be made to the embodiments disclosed herein. Therefore, the above description should not be construed as limiting, but merely as exemplifications of preferred embodiments. Those skilled in the art will envision other modifications within the scope and spirit of the claims append hereto.

What is claimed is:

1. A surgical portal apparatus, which comprises:
 - a portal member defining a longitudinal axis and having a longitudinal passageway therethrough for receiving a surgical object;
 - an adjustable seal disposed within the longitudinal passageway, the adjustable seal including first and second seal elements each having inner seal portions dimensioned and adapted to permit passage of the surgical object in substantial sealed relation therewith; and
 - an adjustment member mounted within the portal member and positioned to intersect the longitudinal passageway to engage the surgical object and move relative to the portal member, the adjustment member being operatively connected to the second seal element such that, during movement of the adjustment member upon engagement with the surgical object, the second seal element moves relative to the first seal element and in a lateral direction second occurrence along an axis extending in orthogonal relation to the longitudinal axis to thereby cause corresponding relative displacement of the inner seal portions of the first and second seal ele-

ments and thereby facilitate passage of the surgical object through the adjustable seal.

2. The surgical portal apparatus according to claim 1 wherein the inner seal portions of the first and second seal elements of the adjustable seal are adapted for relative movement between a first generally approximated position and a second generally displaced position upon movement of the adjustment member and the second element.

3. The surgical portal apparatus according to claim 2 wherein the inner seal portions of the first and second seal elements of the adjustable seal are dimensioned to substantially prevent passage of fluids when in the first generally approximated position.

4. The surgical portal apparatus according to claim 2 wherein the portal member includes a portal housing and a portal sleeve extending from the portal housing.

5. The surgical portal apparatus according to claim 2 wherein the first seal element is secured to the portal member and the second seal element is independent of the first seal element, the second seal element adapted to translate within the longitudinal passageway of the portal member upon movement of the adjustment member.

6. The surgical portal apparatus according to claim 5 wherein the second seal element is adapted for lateral movement relative to the longitudinal axis during movement between the first generally approximated position and the second generally displaced position.

7. The surgical portal apparatus according to claim 5 wherein the adjustment member is adapted for pivotal movement relative to the portal member.

8. The surgical portal apparatus according to claim 5 including a gear member operatively connected to the adjustment member and to the second seal element, the gear member adapted to translate movement of the adjustment member to corresponding movement of the second seal element.

9. The surgical portal apparatus according to claim 5 wherein the adjustment member is adapted for movement between an initial position and an activated position, the initial position and the activated position corresponding to the first generally approximated position and the second generally displaced position of the inner portions of the adjustable seal.

10. The surgical portal apparatus according to claim 9 wherein the adjustment member includes a zero closure seal, the zero closure seal adapted to substantially close the longitudinal opening when in the first position of the adjustment member.

11. The surgical portal apparatus according to claim 9 wherein the adjustment member is normally biased toward the initial position thereof.

12. The surgical portal apparatus according to claim 5 including a secondary seal mounted to the portal member.

13. The surgical portal apparatus according to claim 12 wherein the adjustable seal is adapted to form a substantial seal about a surgical object having a first cross-sectional dimension and the secondary seal is adapted to form a substantial seal about a surgical object having a second cross-sectional dimension, the second cross-sectional dimension being greater than the first cross-sectional dimension.

14. The surgical portal apparatus according to claim 13 wherein the adjustable seal is adapted to form a seal about a surgical object having a diameter ranging from about 4 mm to about 6 mm, and wherein the secondary seal is adapted to form a seal about a surgical object having a diameter ranging from about 9 mm to about 13 mm.

15. The surgical portal apparatus according to claim **12** wherein the adjustable seal is mounted distal to the secondary seal.

16. A surgical portal apparatus, which comprises:

a portal member defining a longitudinal axis and having a longitudinal passageway therethrough for receiving a surgical object;

an adjustable seal disposed within the longitudinal passageway, the adjustable seal including:

a first seal element secured to the portal member and having inner seal surfaces; and

a second seal element independent of the first seal element and adapted to translate within the longitudinal passageway of the portal member in a lateral direction along an axis extending in orthogonal relation to the longitudinal axis and relative to the first seal element between an approximated position and a displaced position, the second seal element having inner seal surfaces cooperating with the inner seal surfaces of the first seal element to establish a general seal about the surgical object; and

an adjustment member mounted for movement within the portal member and positioned to intersect the longitudinal passageway to engage the surgical object, the adjustment member operatively connected to the second seal element to cause movement of the second seal element

from the approximated position to the displaced position during movement thereof within the portal member.

17. The surgical portal apparatus according to claim **16** including a rack and pinion associated with the second seal element and the adjustment member to cause movement of the second seal element between the approximated position and the displaced position.

18. The surgical portal apparatus according to claim **17** wherein the adjustment member is mounted for pivotal movement within the portal member.

19. The surgical portal apparatus according to claim **18** wherein the adjustment member is normally biased toward the initial position thereof.

20. The surgical portal apparatus according to claim **16** wherein the adjustment member is adapted for movement between an initial position and an activated position, the initial position and the activated position corresponding to the approximated position and the displaced position of the second seal element.

21. The surgical portal apparatus according to claim **20** wherein the adjustment member is dimensioned and configured to substantially close the longitudinal passageway of the portal member when in the initial position thereof.

22. The surgical portal apparatus according to claim **21** wherein the adjustment member is normally biased toward the initial position thereof.

* * * * *