

US007722146B2

(12) **United States Patent**  
**Walmsley**

(10) **Patent No.:** **US 7,722,146 B2**  
(45) **Date of Patent:** **\*May 25, 2010**

(54) **PRINTING SYSTEM HAVING CONTROLLED MULTI-LENGTH PRINthead ICS**

(75) Inventor: **Simon Robert Walmsley**, Balmain (AU)

(73) Assignee: **Silverbrook Research Pty Ltd**,  
Balmain, New South Wales (AU)

(\* ) Notice: Subject to any disclaimer, the term of this patent is extended or adjusted under 35 U.S.C. 154(b) by 0 days.

This patent is subject to a terminal disclaimer.

(21) Appl. No.: **12/436,129**

(22) Filed: **May 6, 2009**

(65) **Prior Publication Data**

US 2009/0251502 A1 Oct. 8, 2009

**Related U.S. Application Data**

(63) Continuation of application No. 12/050,941, filed on Mar. 19, 2008, now Pat. No. 7,540,579, which is a continuation of application No. 10/727,245, filed on Dec. 2, 2003, now Pat. No. 7,399,043.

(30) **Foreign Application Priority Data**

Dec. 2, 2002 (AU) ..... 2002953134  
Dec. 2, 2002 (AU) ..... 2002953135

(51) **Int. Cl.**  
**B41J 29/38** (2006.01)  
**B41J 2/155** (2006.01)

(52) **U.S. Cl.** ..... **347/13; 347/14; 347/42**

(58) **Field of Classification Search** ..... **347/12-14, 347/42, 5**

See application file for complete search history.

(56) **References Cited**

U.S. PATENT DOCUMENTS

5,198,054 A	3/1993	Drake et al.
5,543,828 A	8/1996	Minowa
5,719,602 A	2/1998	Hackleman et al.
6,168,251 B1	1/2001	Imanaka et al.
6,354,689 B1	3/2002	Couwenhoven et al.
6,637,860 B1	10/2003	Madeley
6,669,331 B2	12/2003	Teshigawara et al.
6,775,022 B2	8/2004	Noyes et al.
6,831,753 B1	12/2004	Tsuchitoui
6,857,724 B2	2/2005	Silverbrook
7,278,697 B2*	10/2007	Plunkett ..... 347/5
2002/0060707 A1	5/2002	Yu et al.
2002/0075339 A1	6/2002	Kamoshida et al.
2002/0158934 A1	10/2002	Oshima
2002/0171709 A1	11/2002	Teshigawara et al.

(Continued)

FOREIGN PATENT DOCUMENTS

EP 0863004 A2 9/1998

(Continued)

*Primary Examiner*—Julian D Huffman  
*Assistant Examiner*—Jason S Uhlenhake

(57) **ABSTRACT**

Printing system is provided which has a plurality of printhead integrated circuits of different lengths and a controller configured to supply print data to the printhead integrated circuits. The printhead integrated circuits are arranged to define a pagewidth printhead having rows of nozzles formed by adjacent nozzle rows of the adjacent printhead integrated circuits. The nozzle rows of the printhead are configured so that there is at least one row for printing each ink color of a plurality of ink colors. The controller supplies the print data at a rate which is proportional to a ratio of the different lengths of the printhead integrated circuits.

**10 Claims, 65 Drawing Sheets**

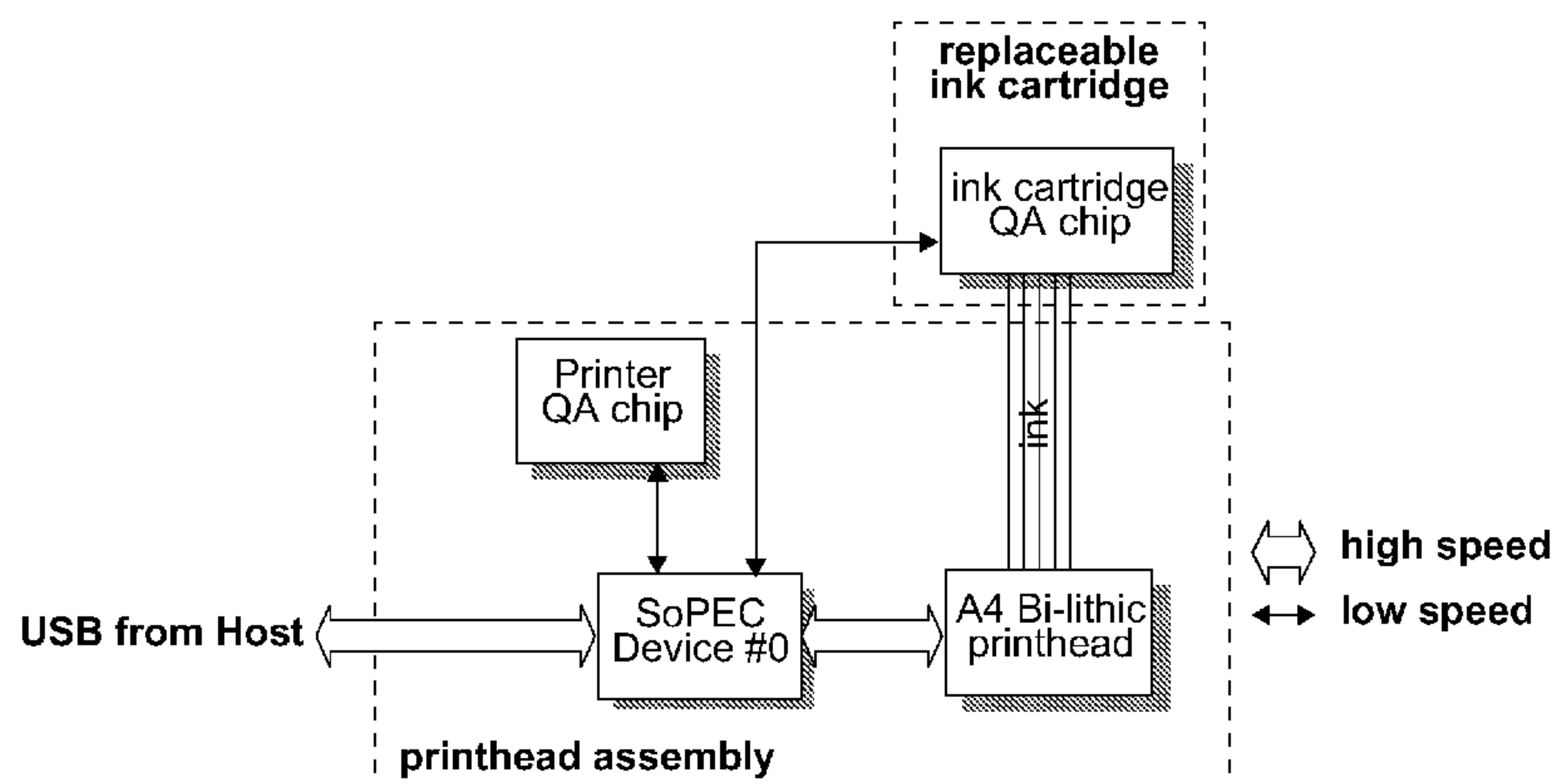

# US 7,722,146 B2

Page 2

---

## U.S. PATENT DOCUMENTS

2002/0180816 A1 12/2002 Haflinger

## FOREIGN PATENT DOCUMENTS

EP 0963854 A 12/1999  
EP 0974467 A1 1/2000

EP 0983855 A2 3/2000  
EP 1157840 A2 11/2001  
JP 01-216852 A 8/1989  
WO WO 98/40222 A1 9/1998  
WO WO 99/08875 A1 2/1999  
WO WO 00/64679 A 11/2000

\* cited by examiner

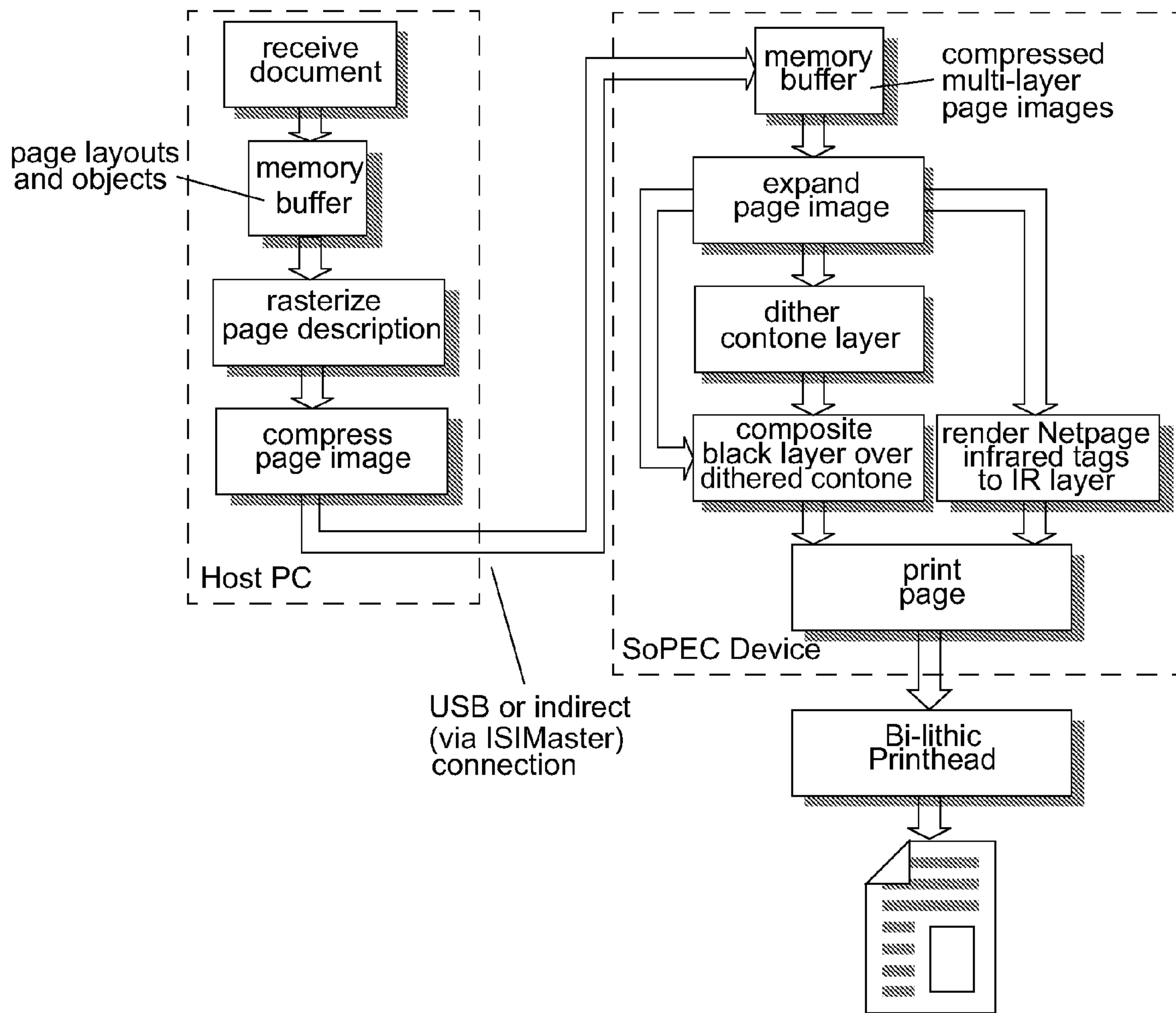

FIG. 1

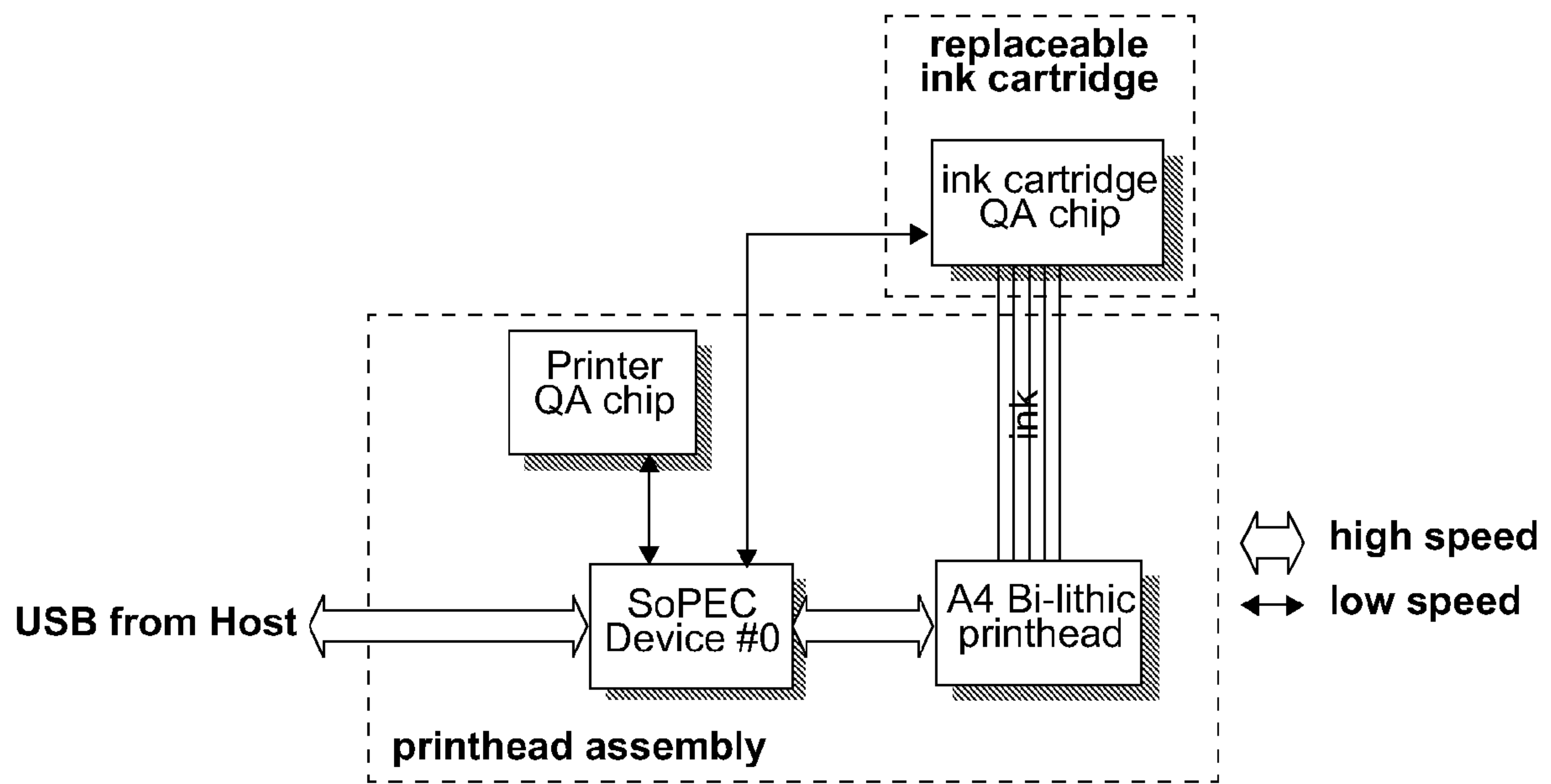

FIG. 2

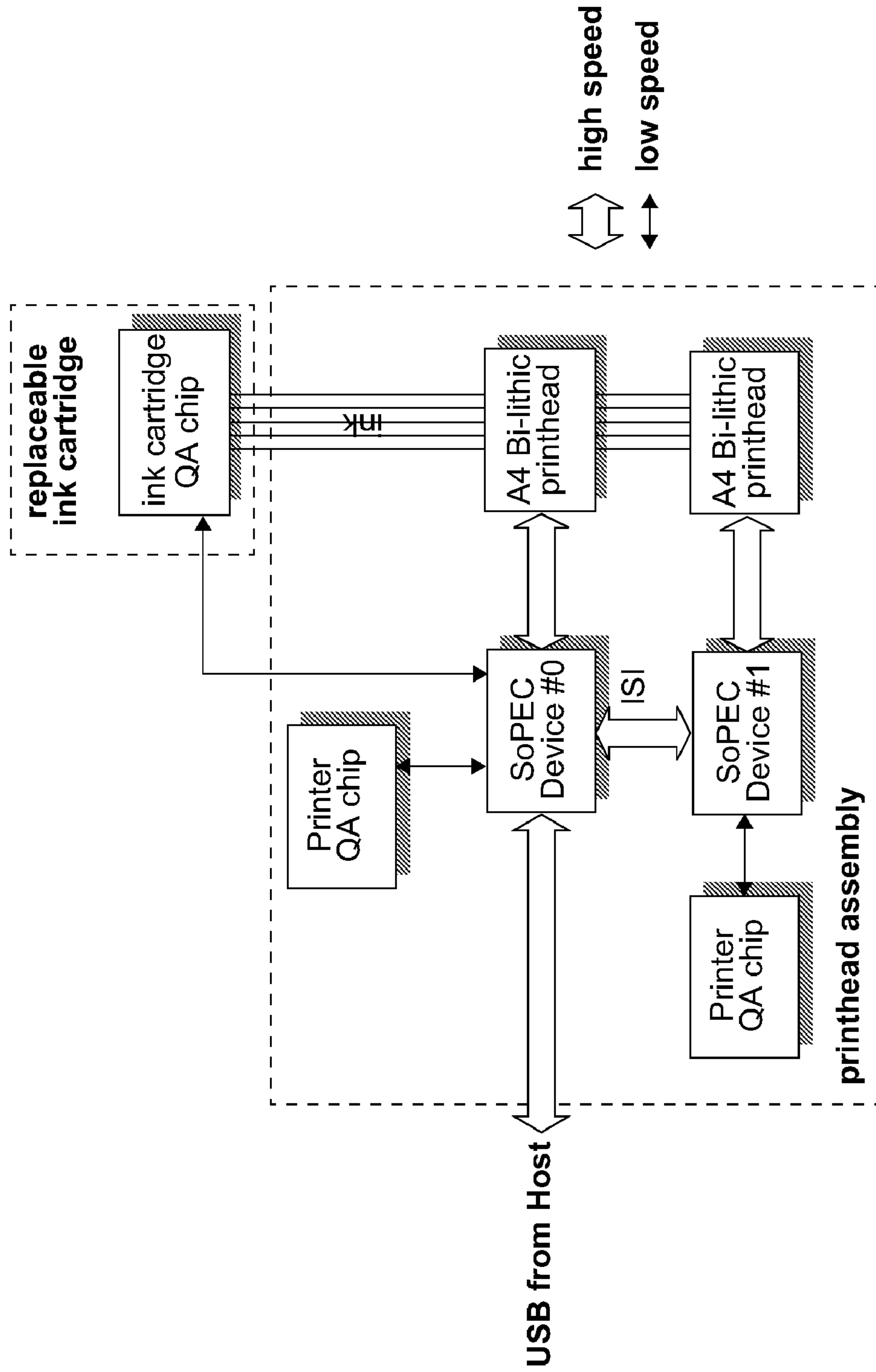

FIG. 3

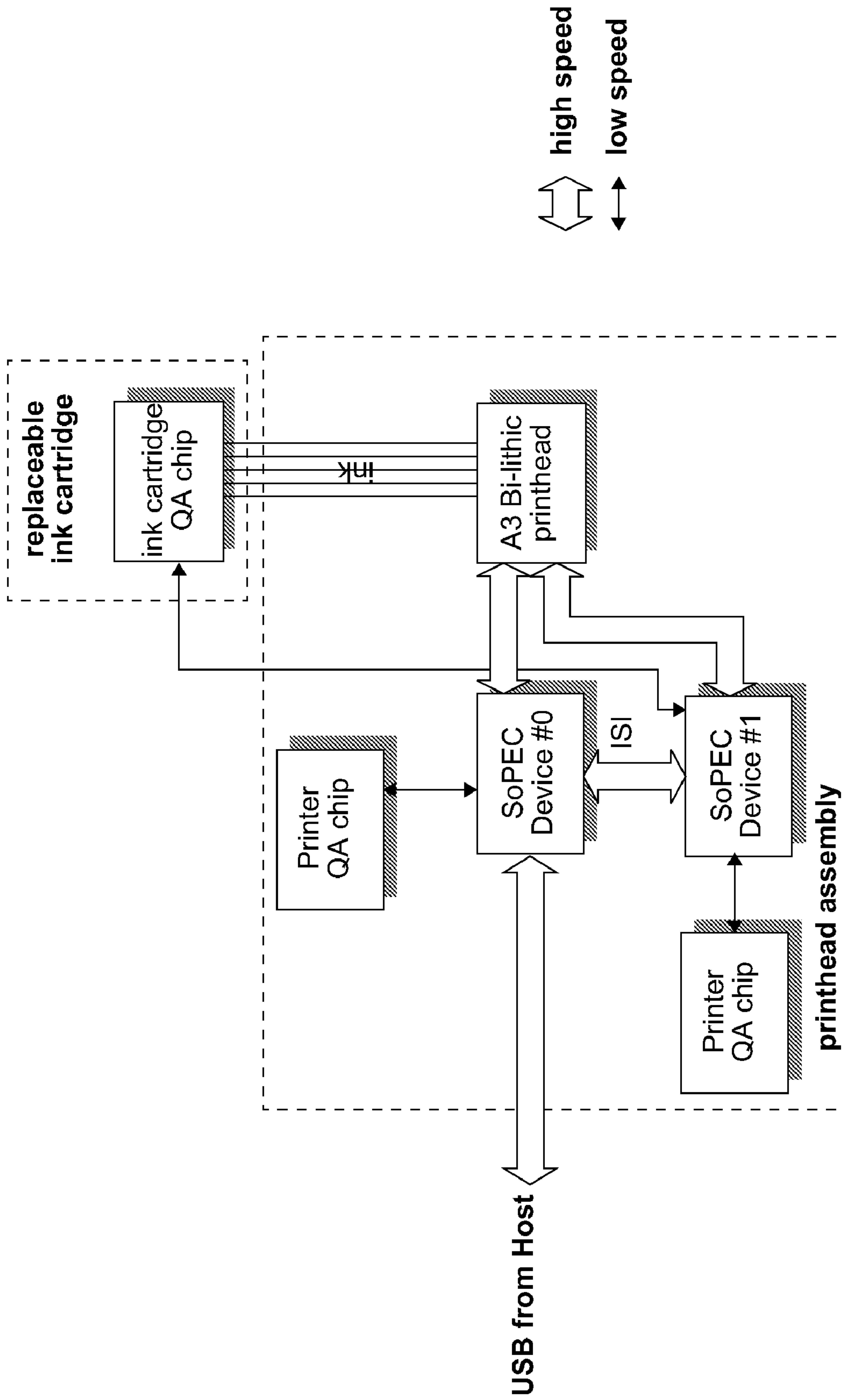

FIG. 4



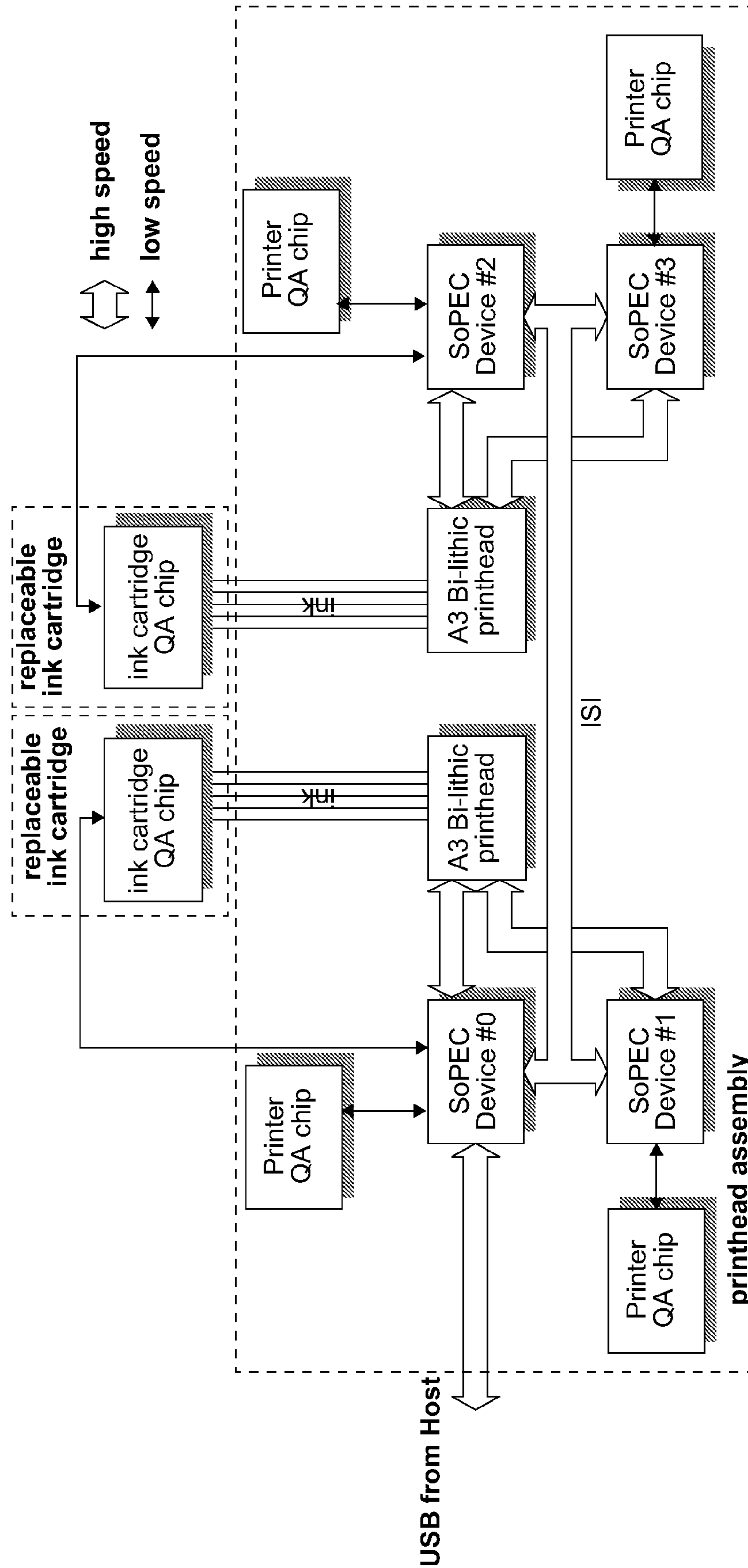

FIG. 5

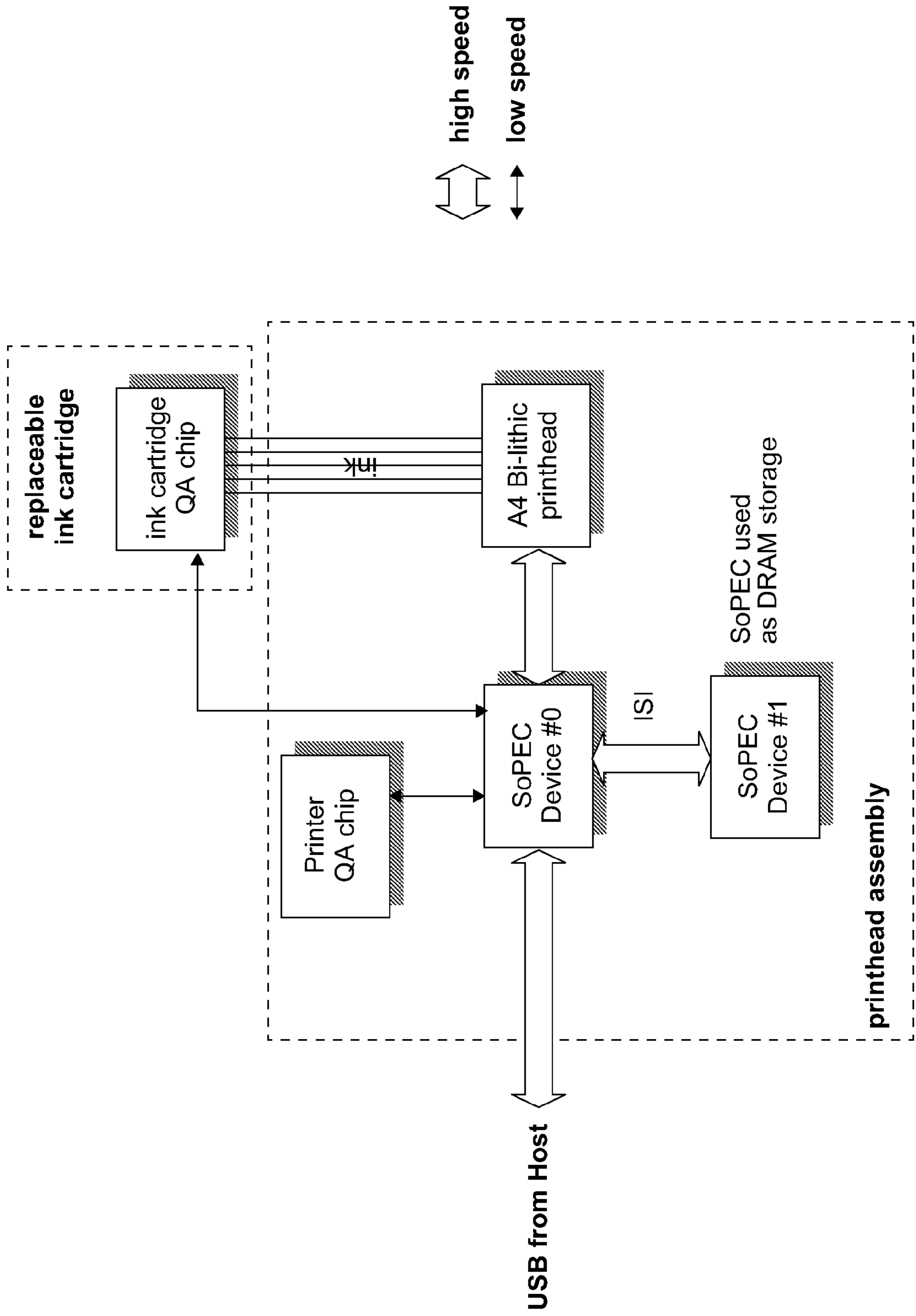

FIG. 6



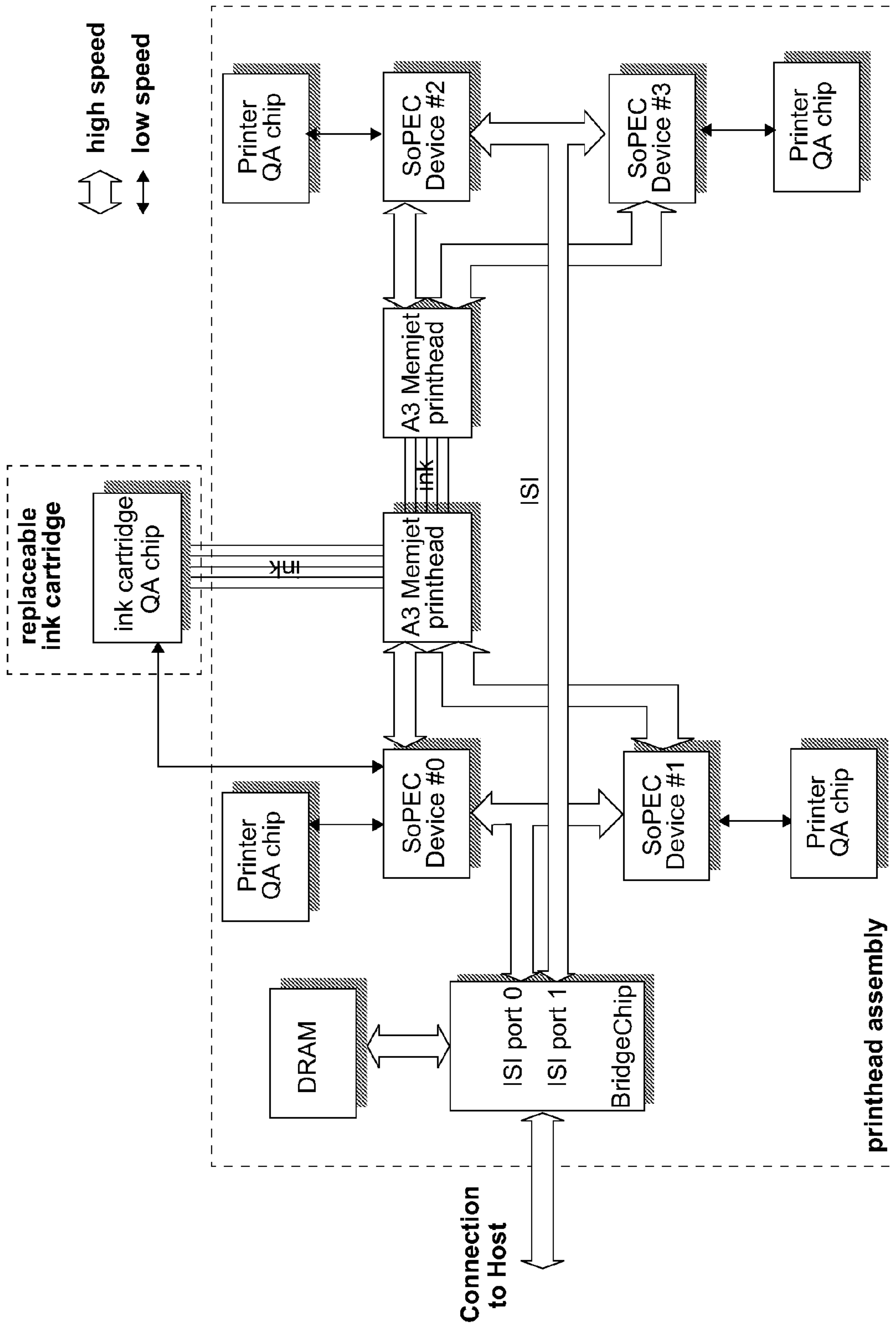

FIG. 7

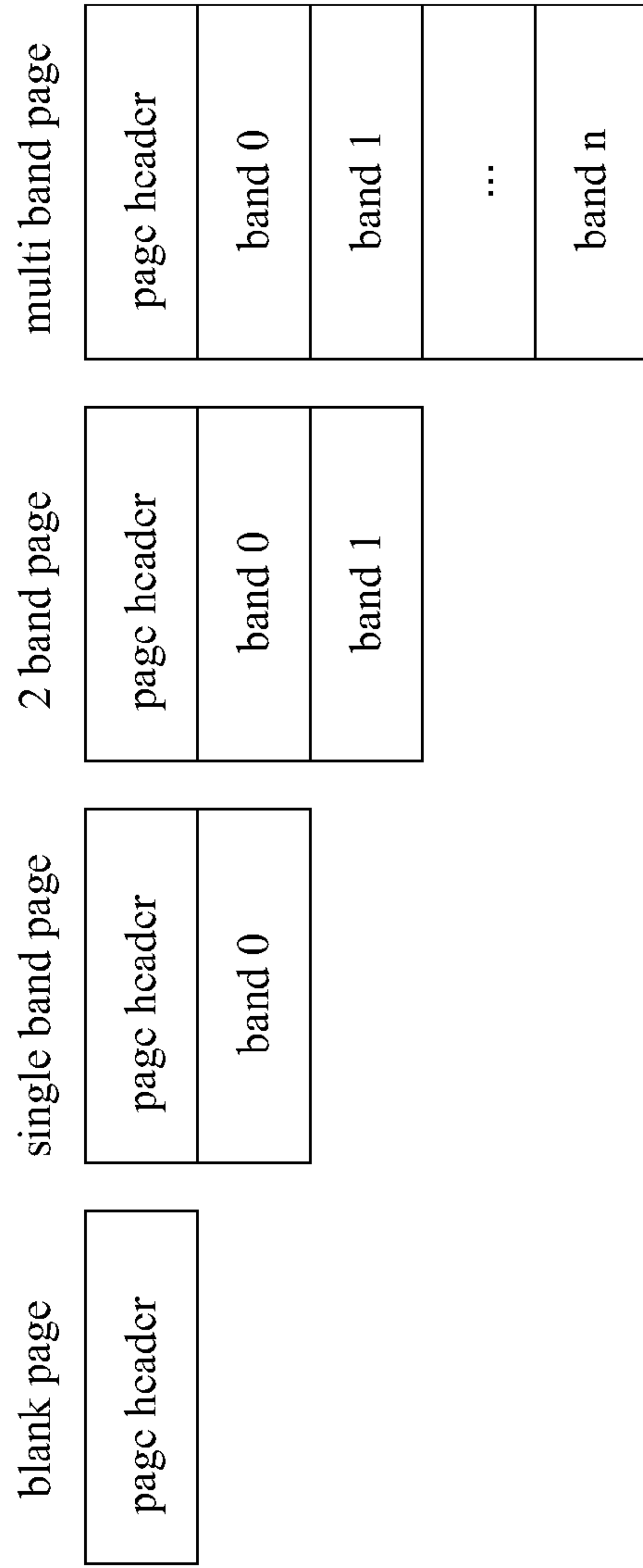

FIG. 8

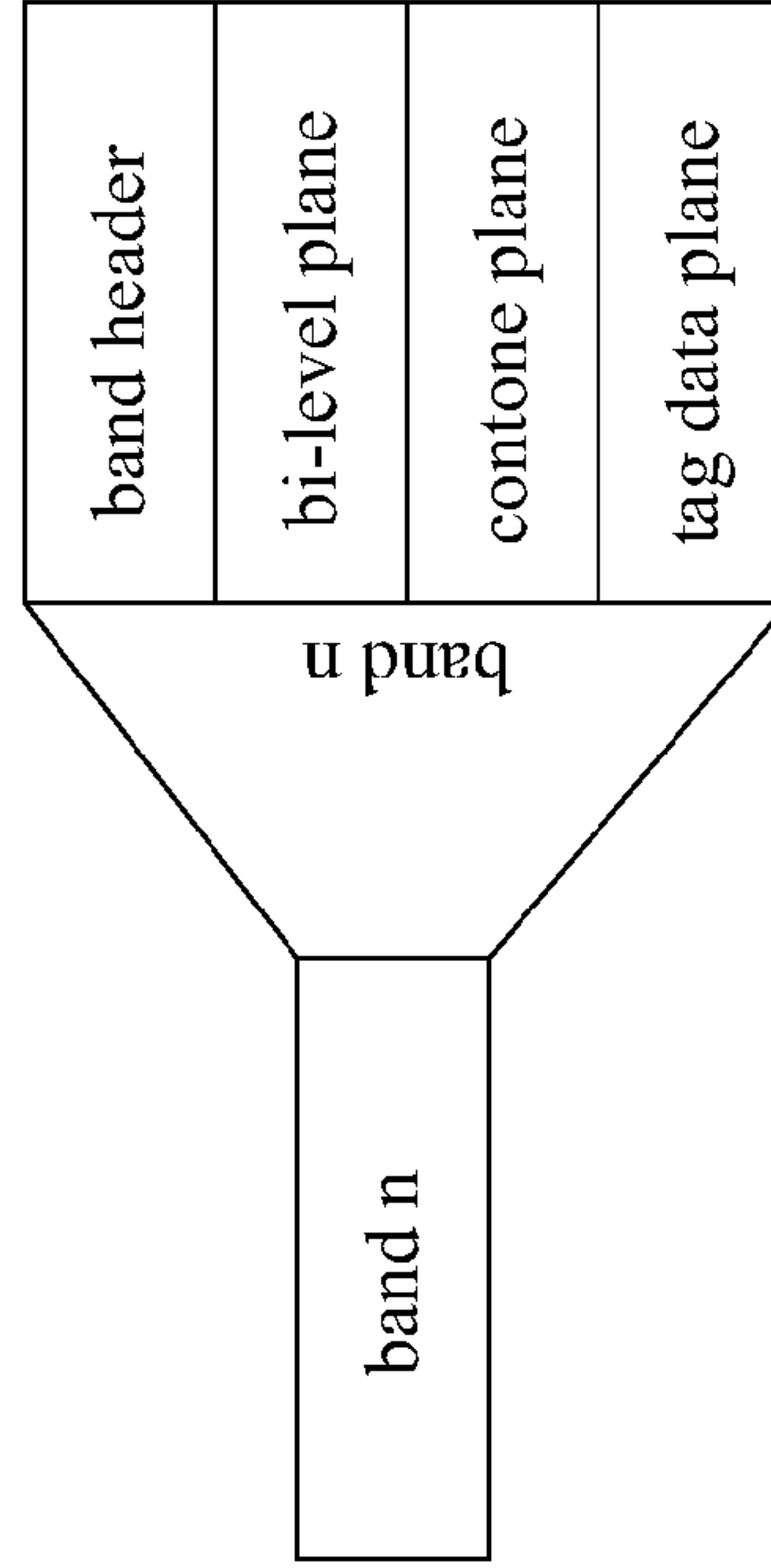

FIG. 9

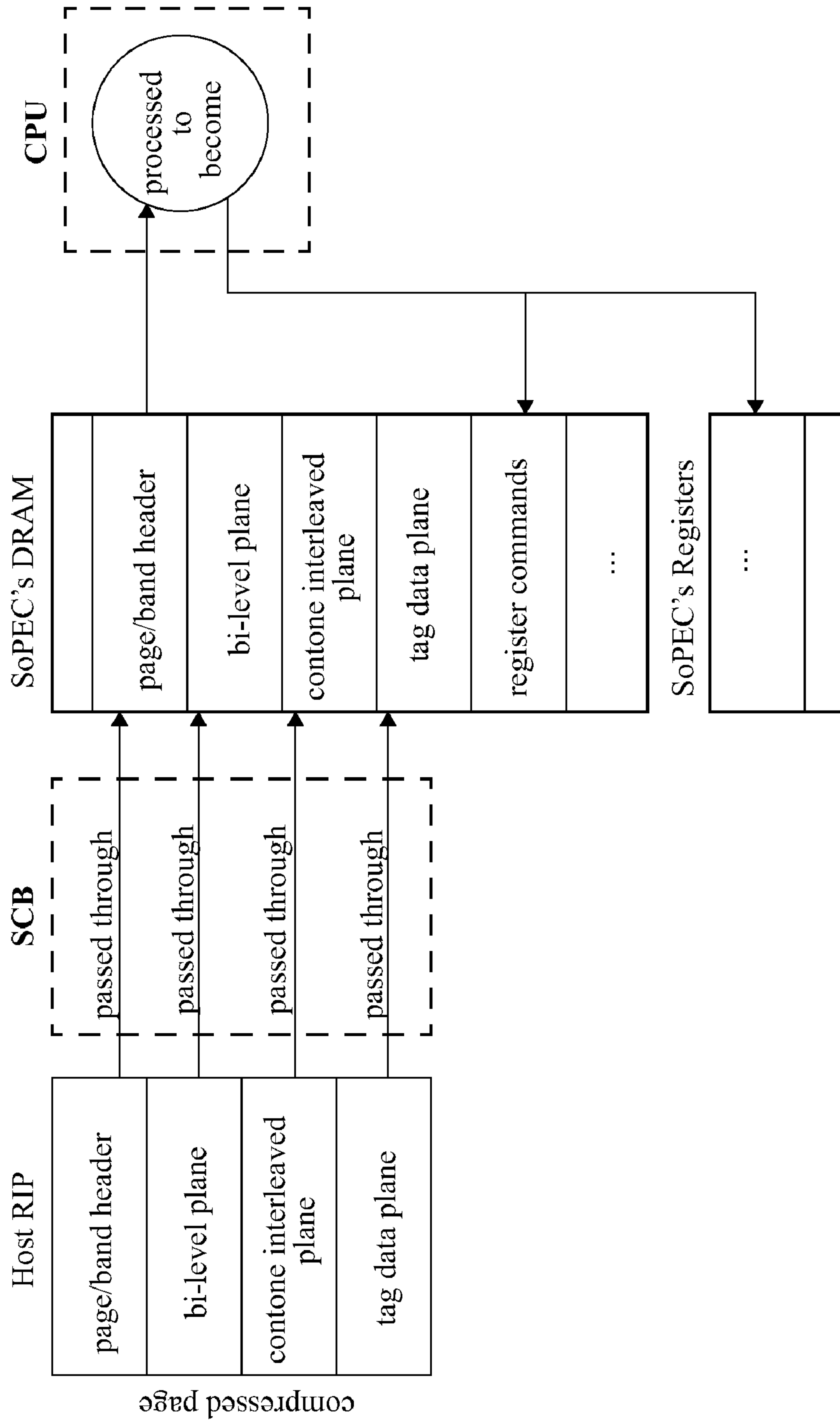

FIG. 10

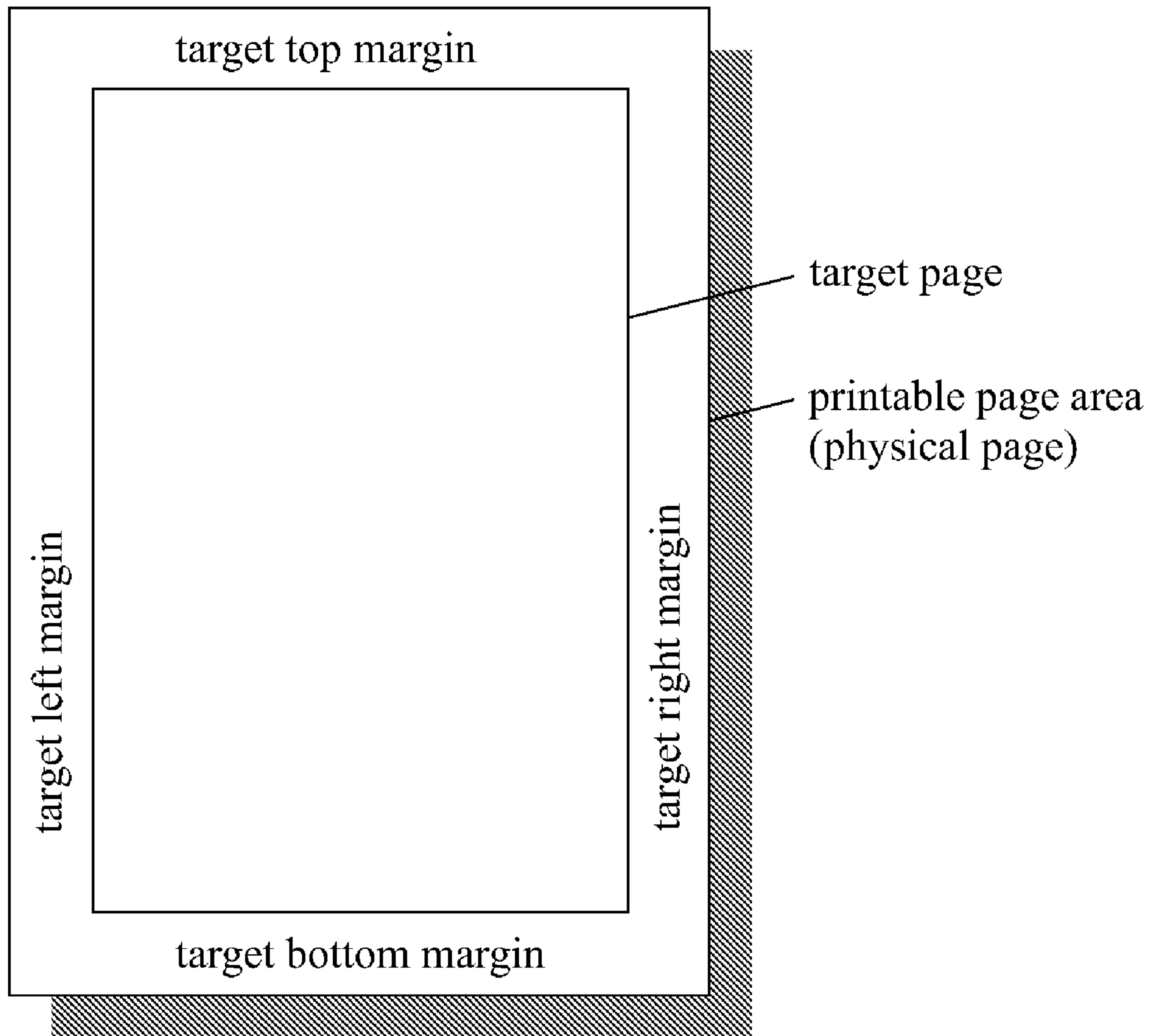

FIG. 11

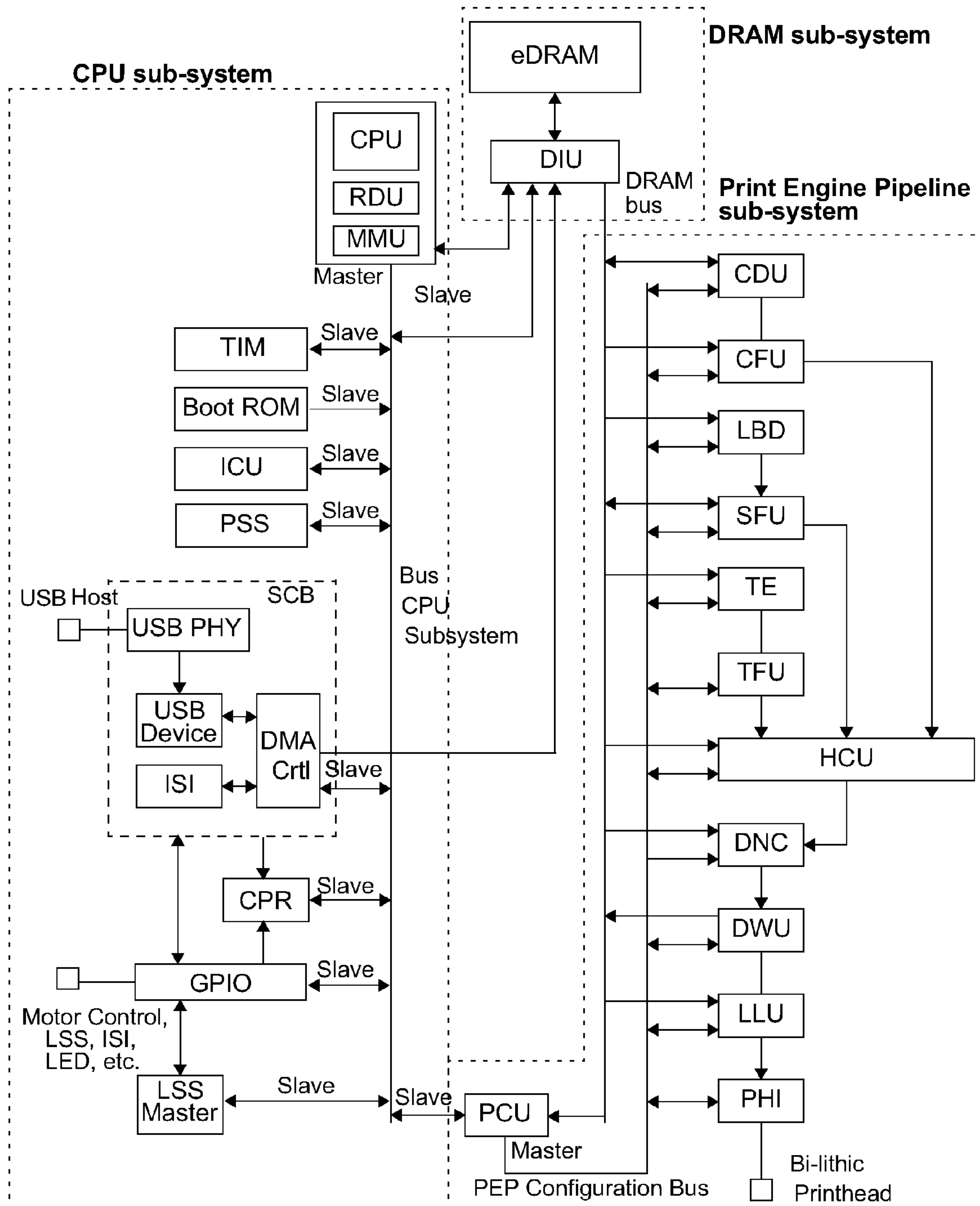

FIG. 12

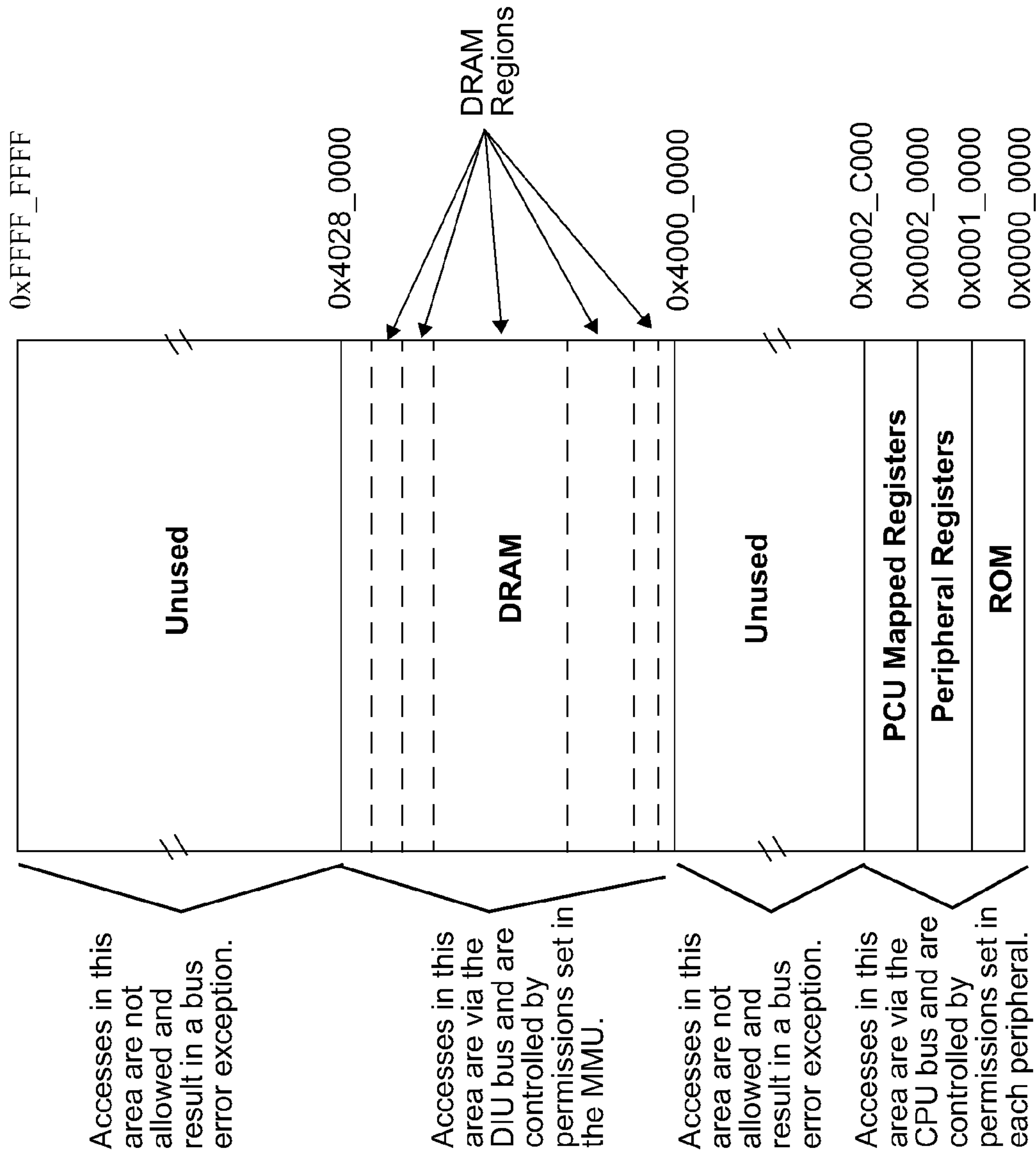

FIG. 13



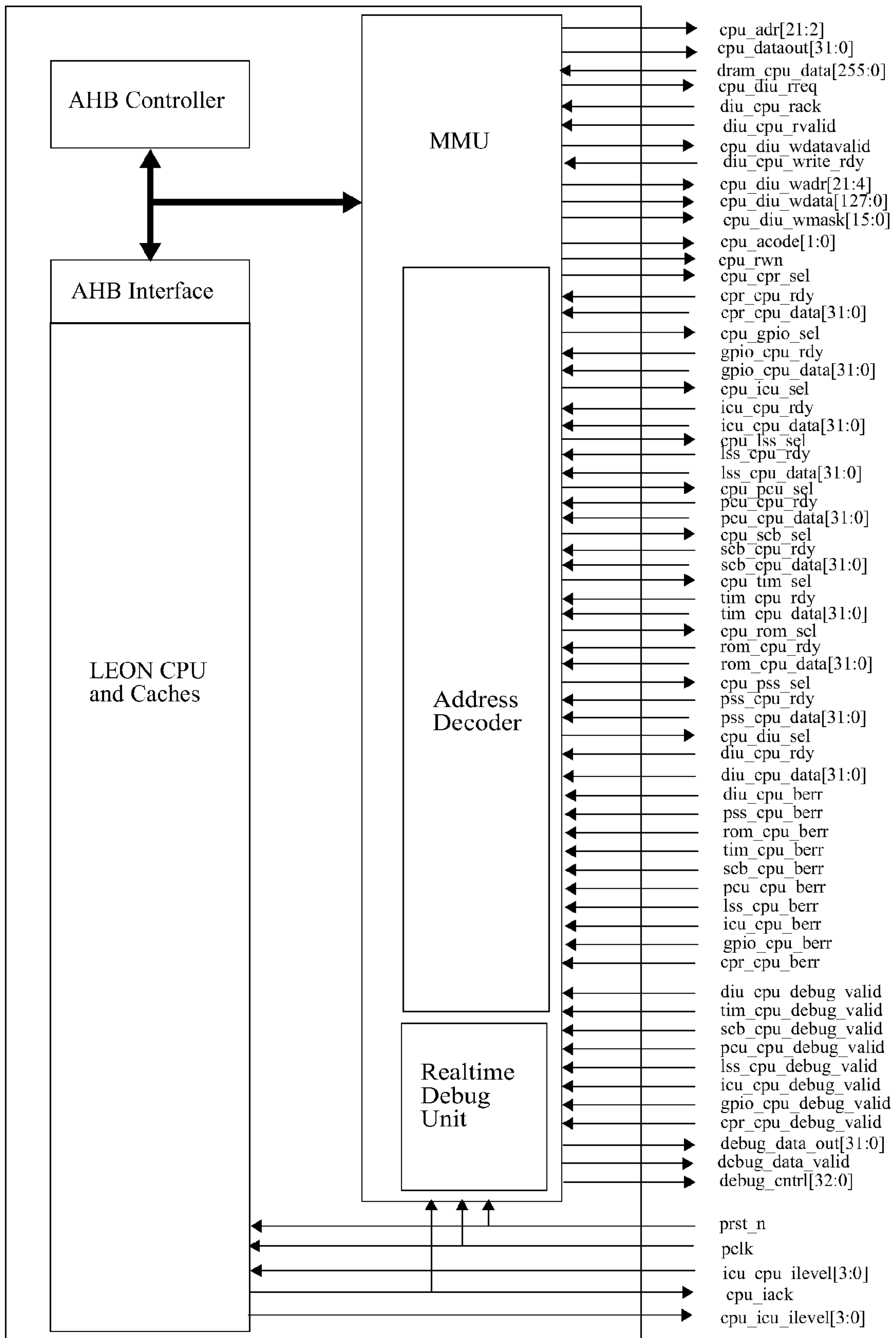

FIG. 14

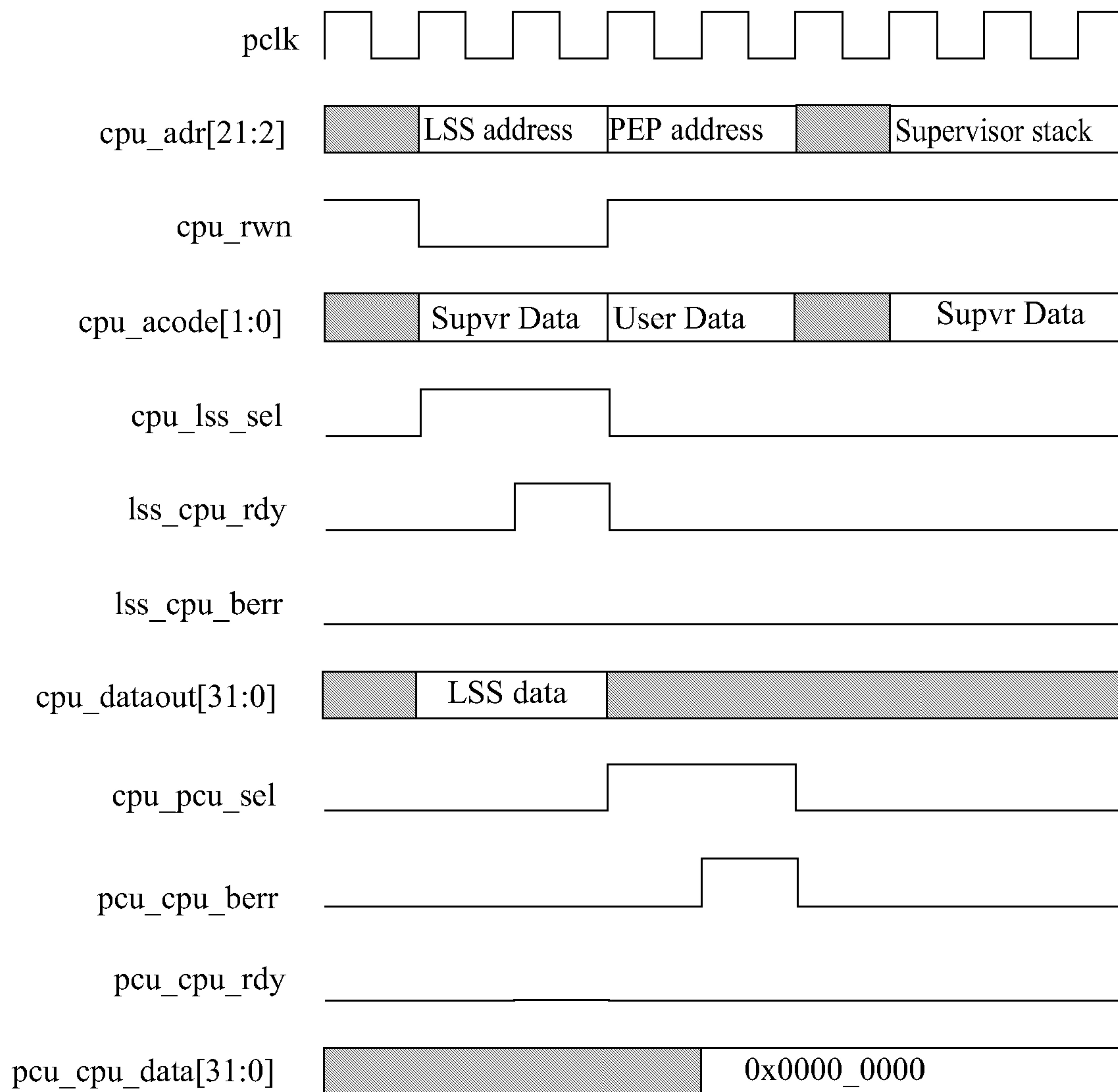

FIG. 15

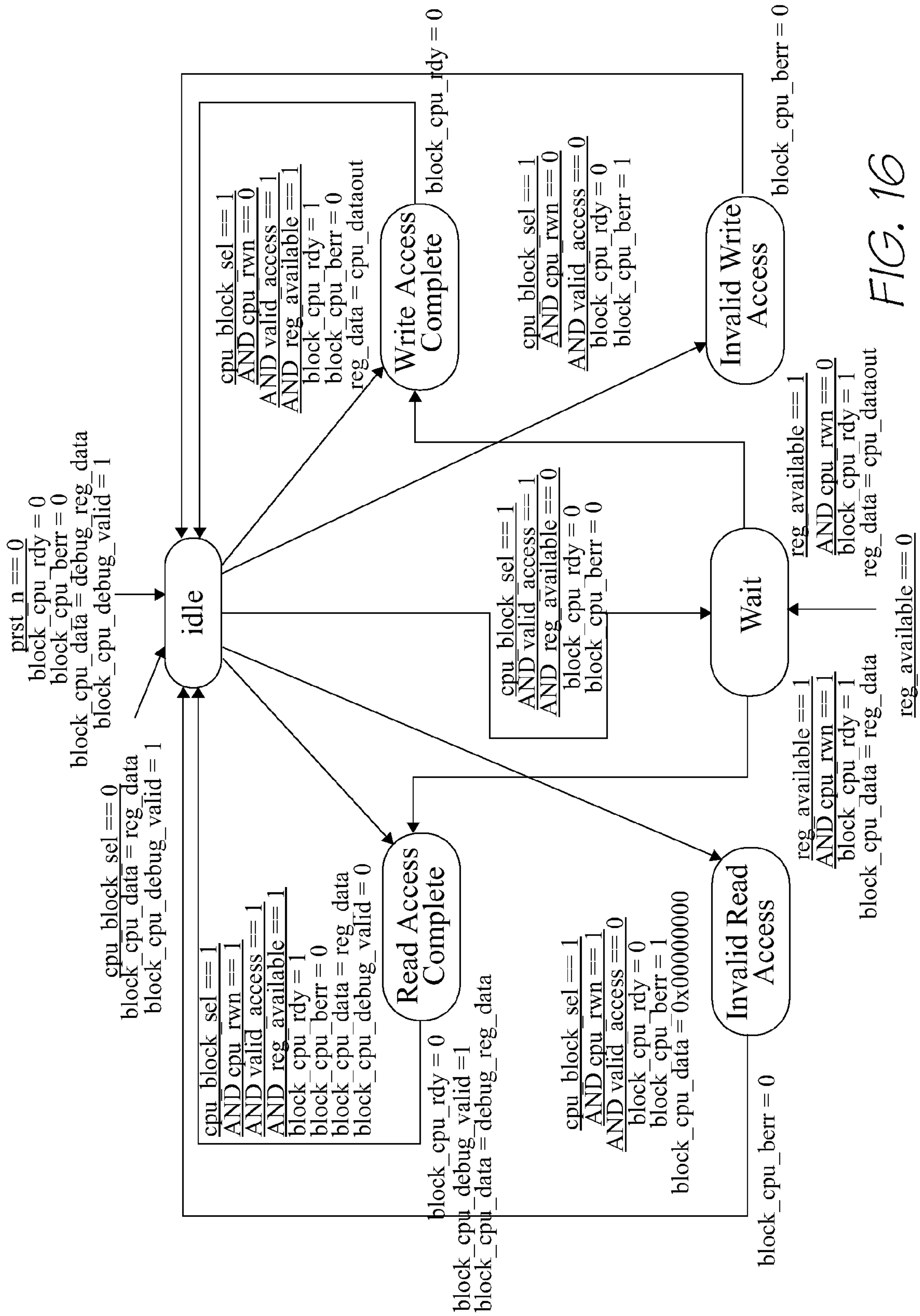

FIG. 16

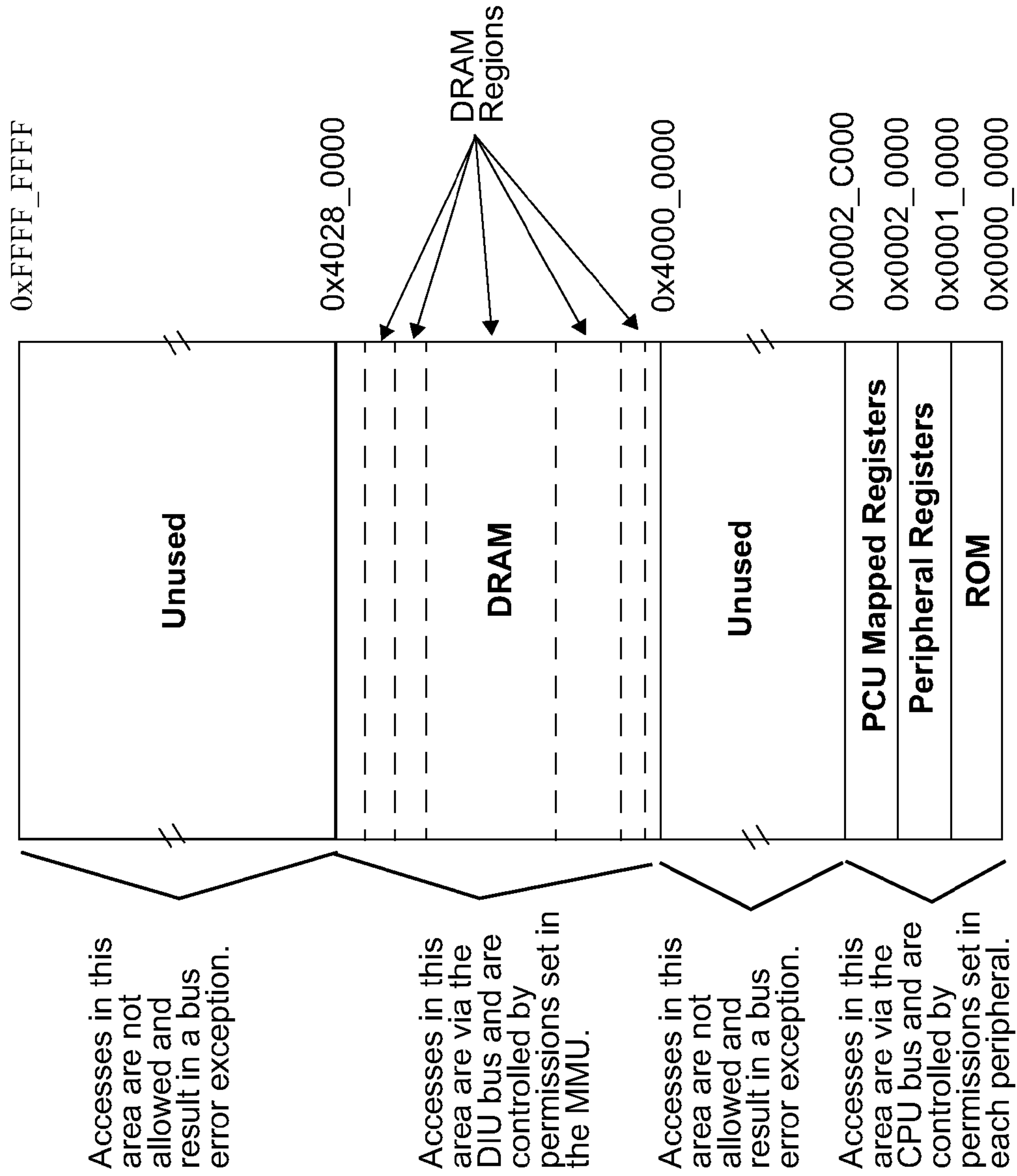

FIG. 17

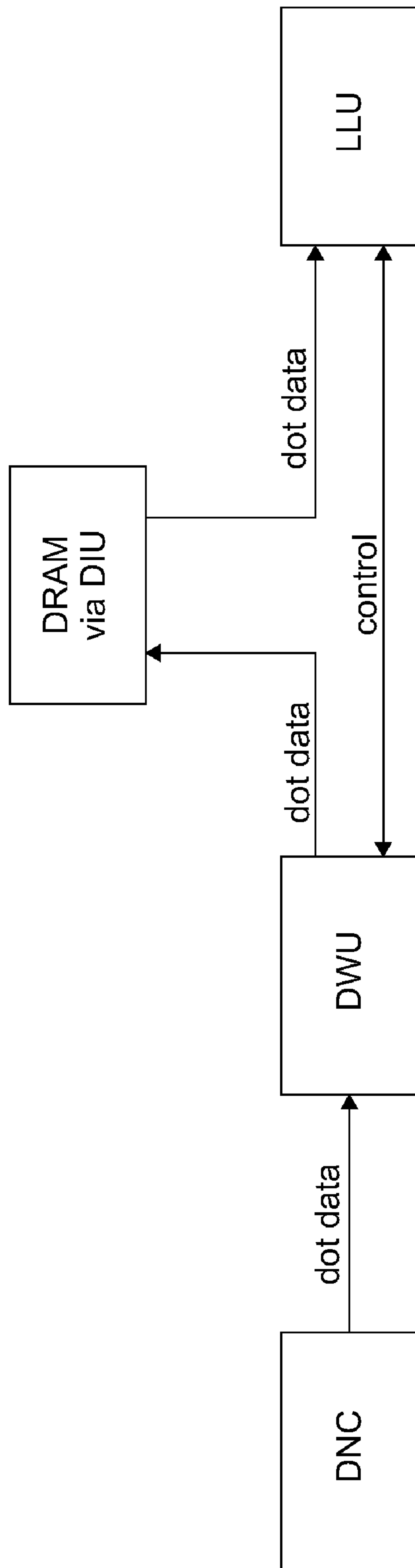
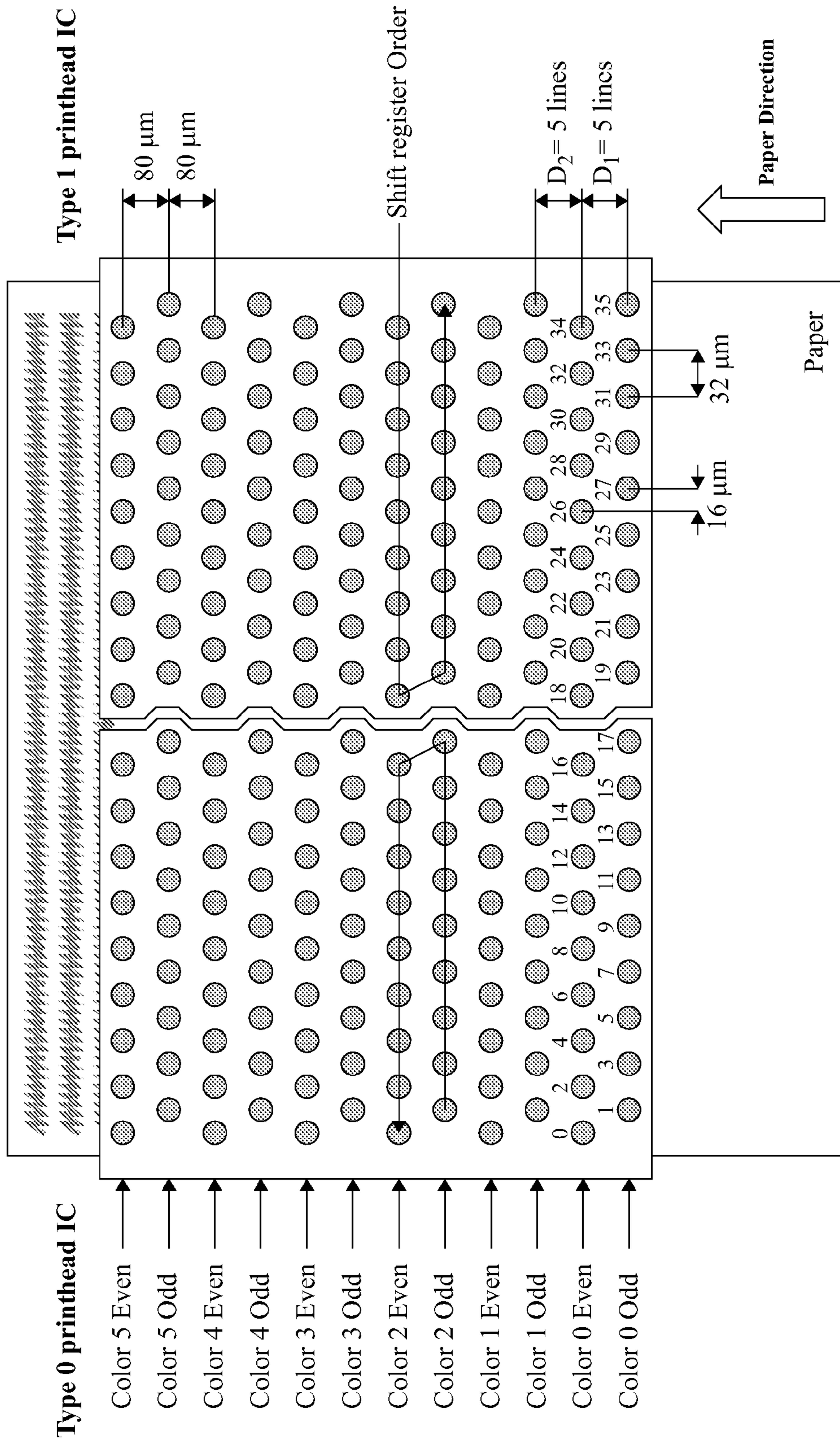

FIG. 18





Note: Paper passes under printhead

FIG. 19



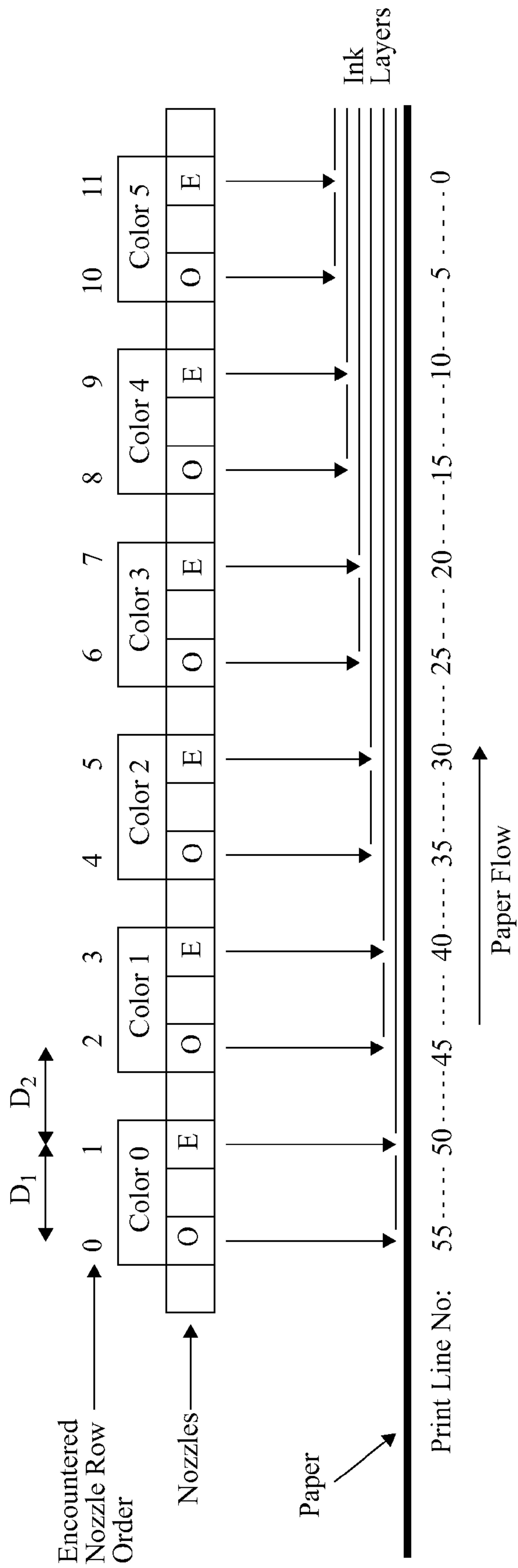

FIG. 20

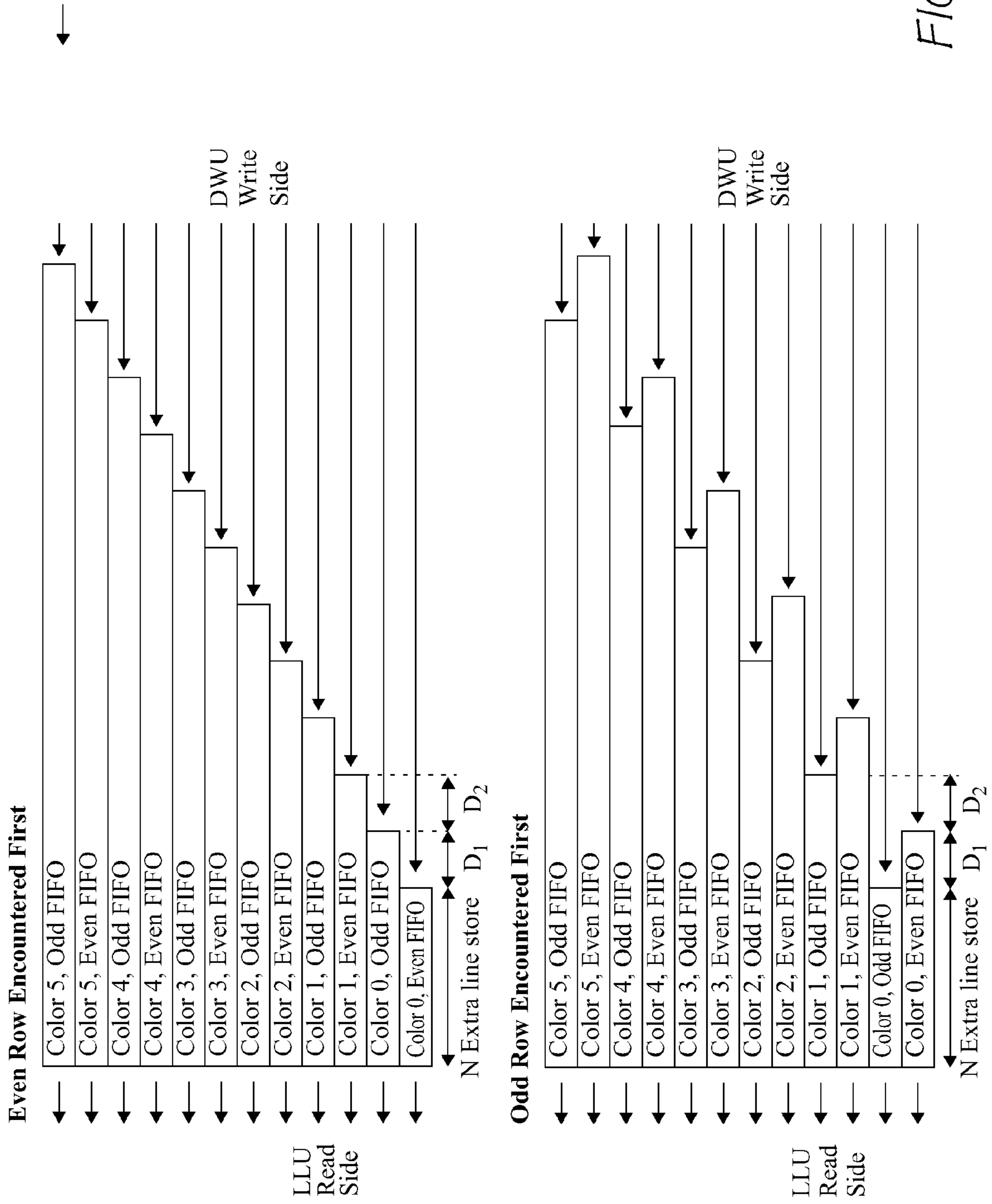

FIG. 21

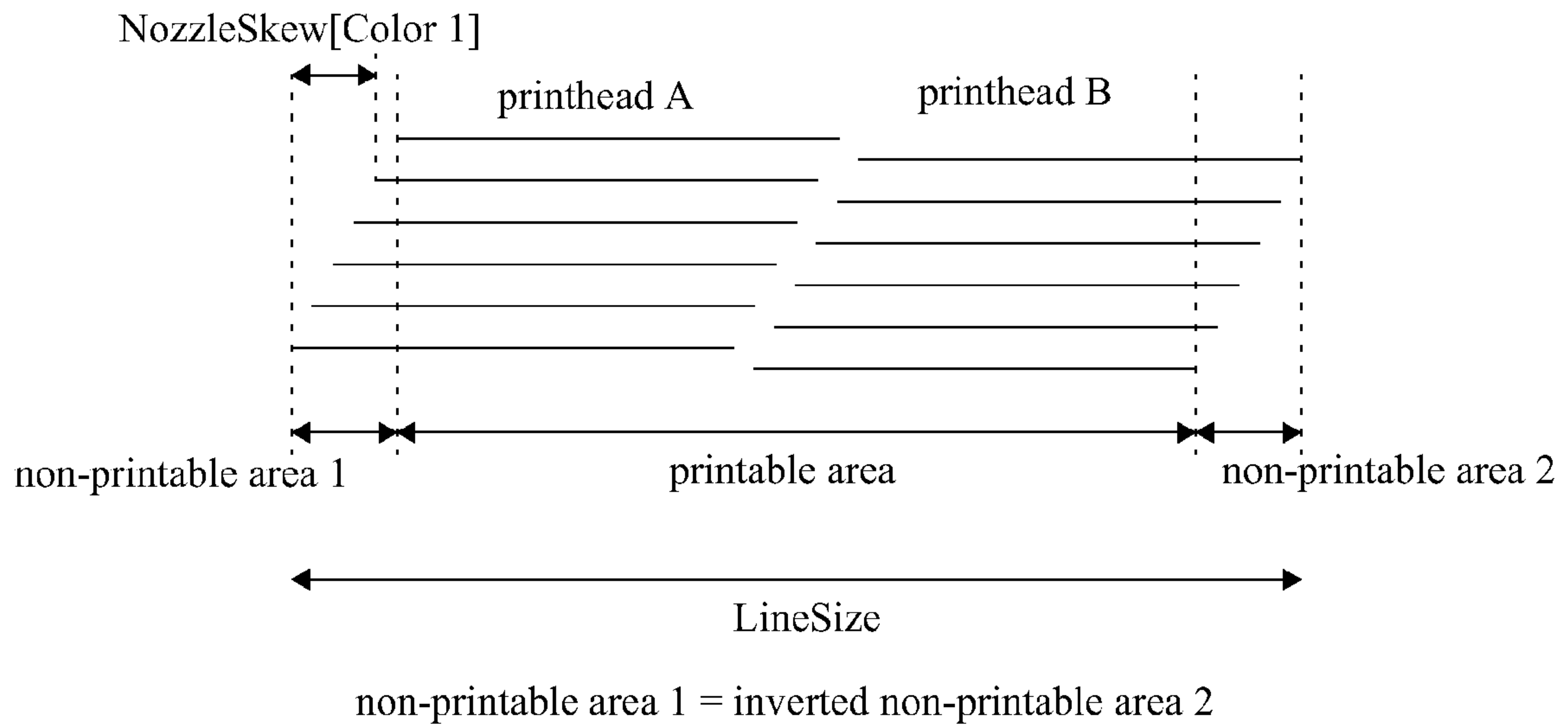

FIG. 22

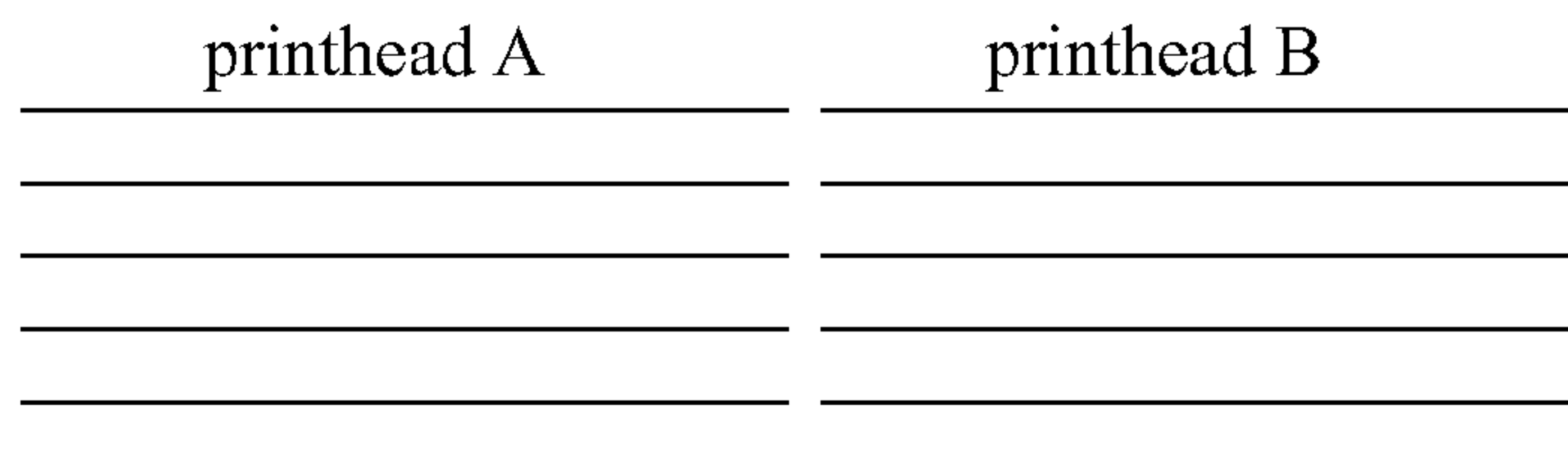

FIG. 23

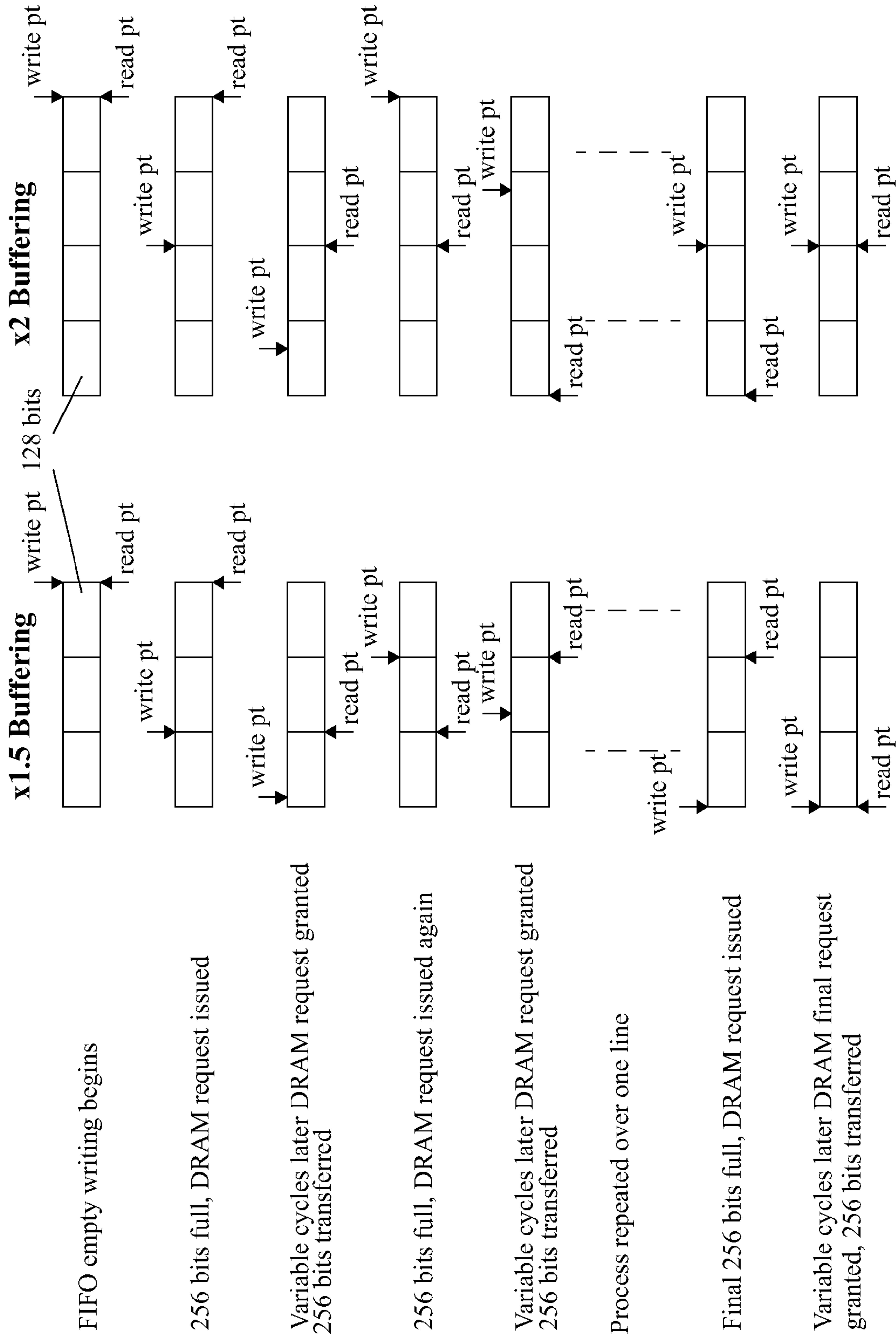

FIG. 24

**Even Dot Storage in DRAM (Increasing Sense)**

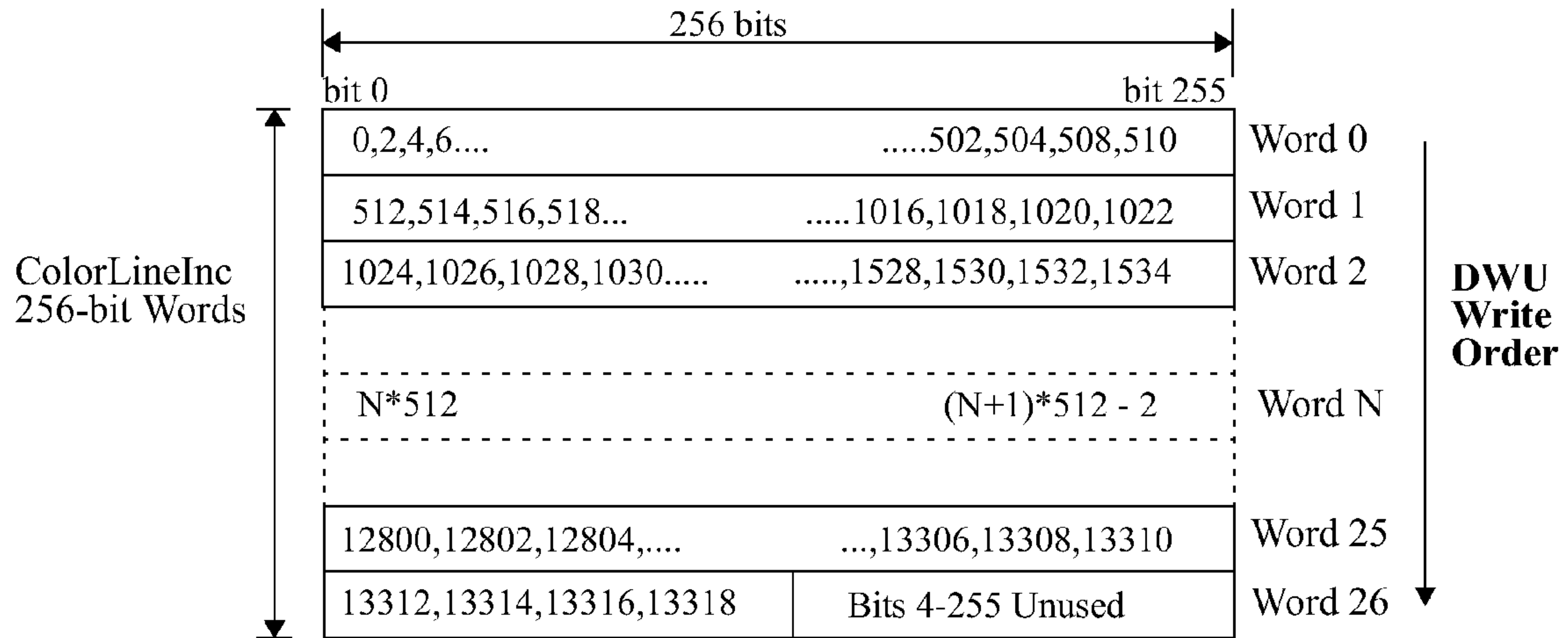

FIG. 25

**Even Dot Storage in DRAM (Decreasing Sense)**

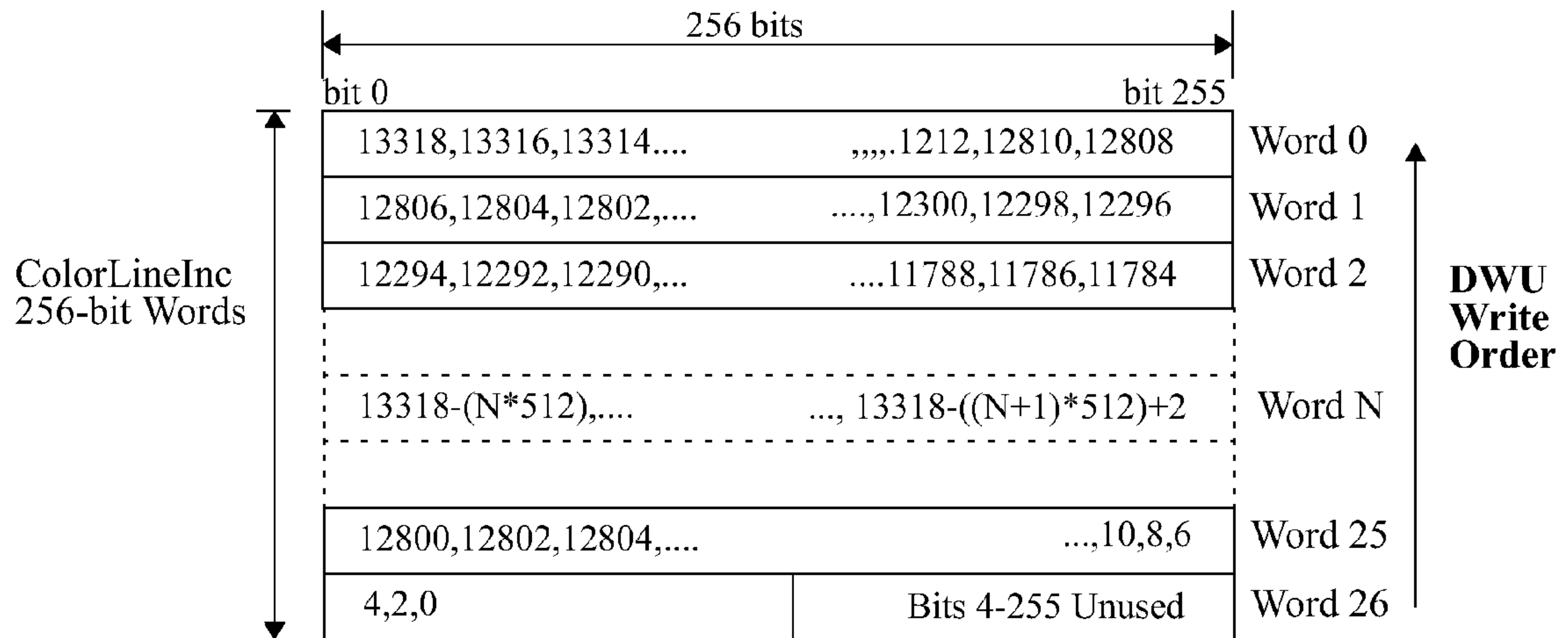

FIG. 26

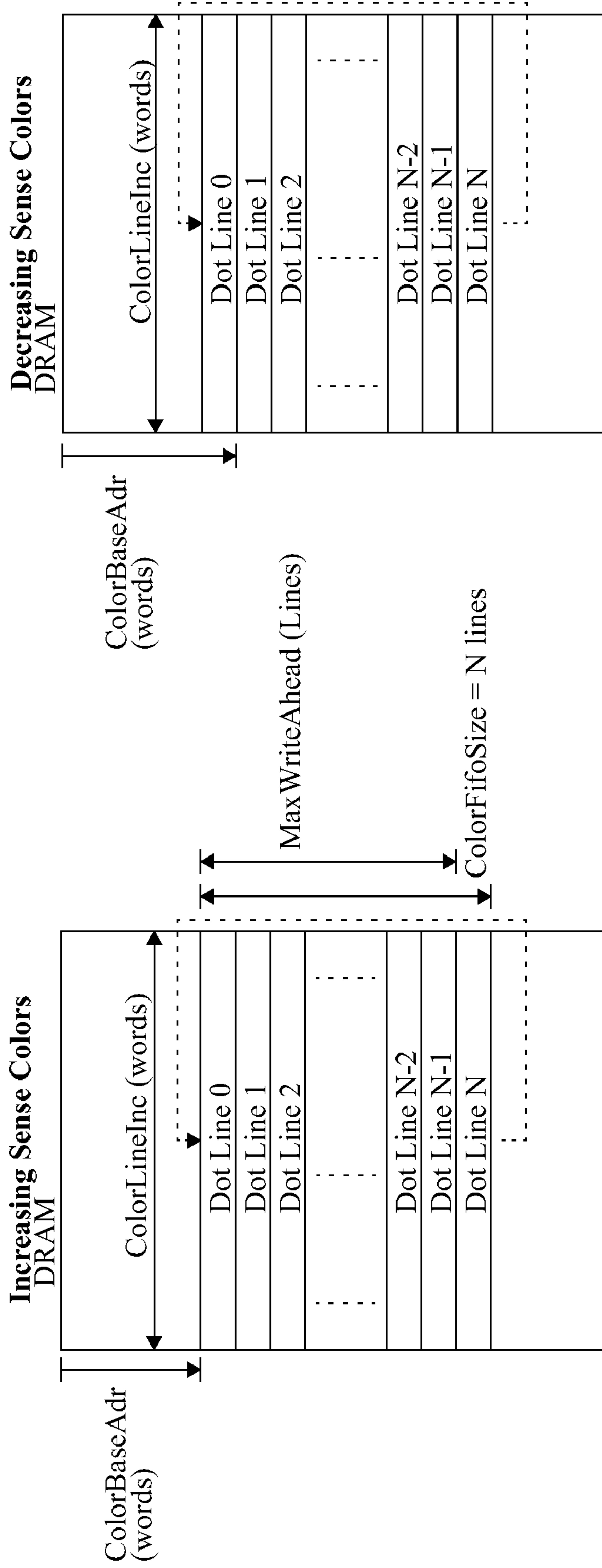

FIG. 27



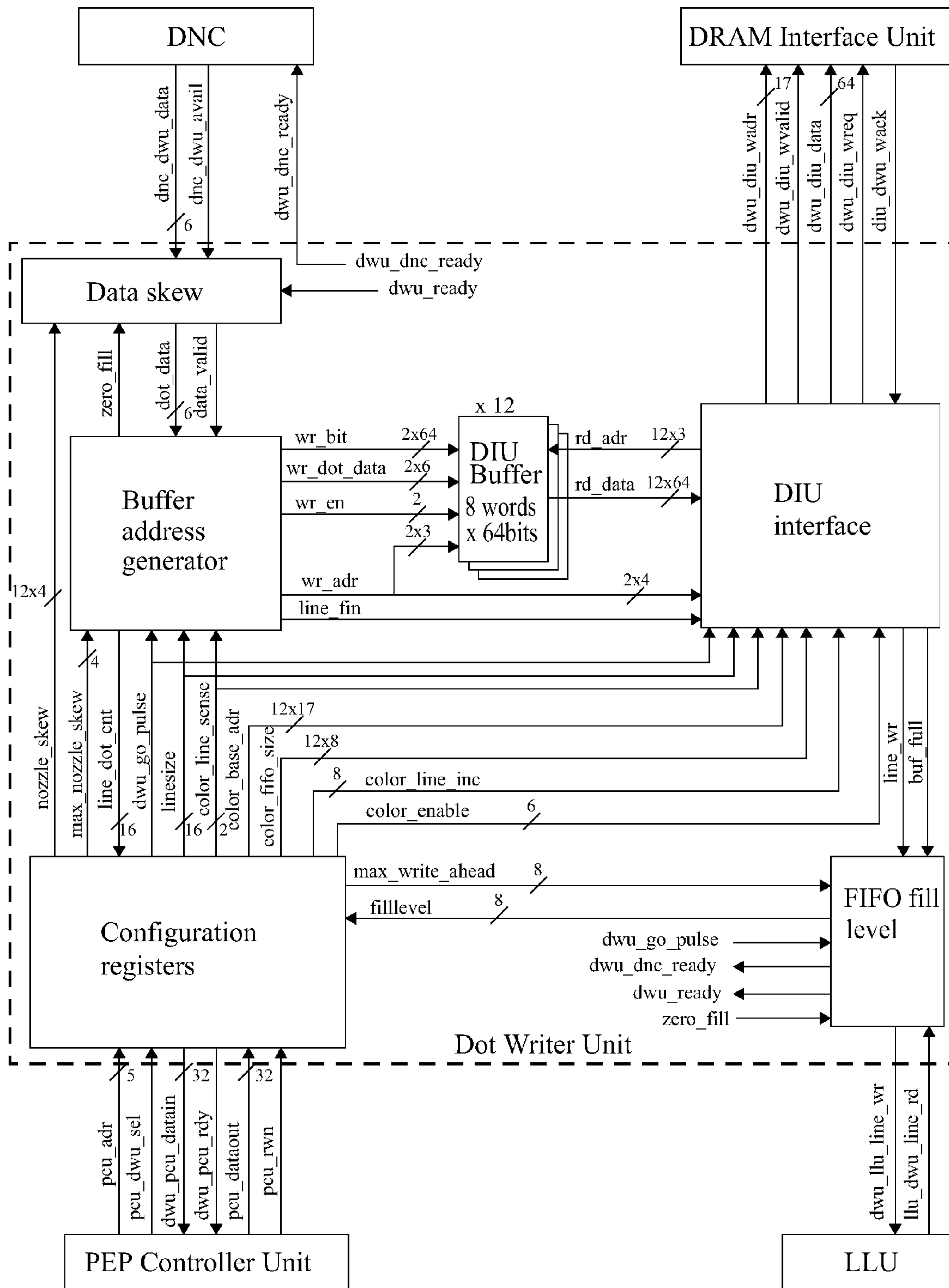

FIG. 28

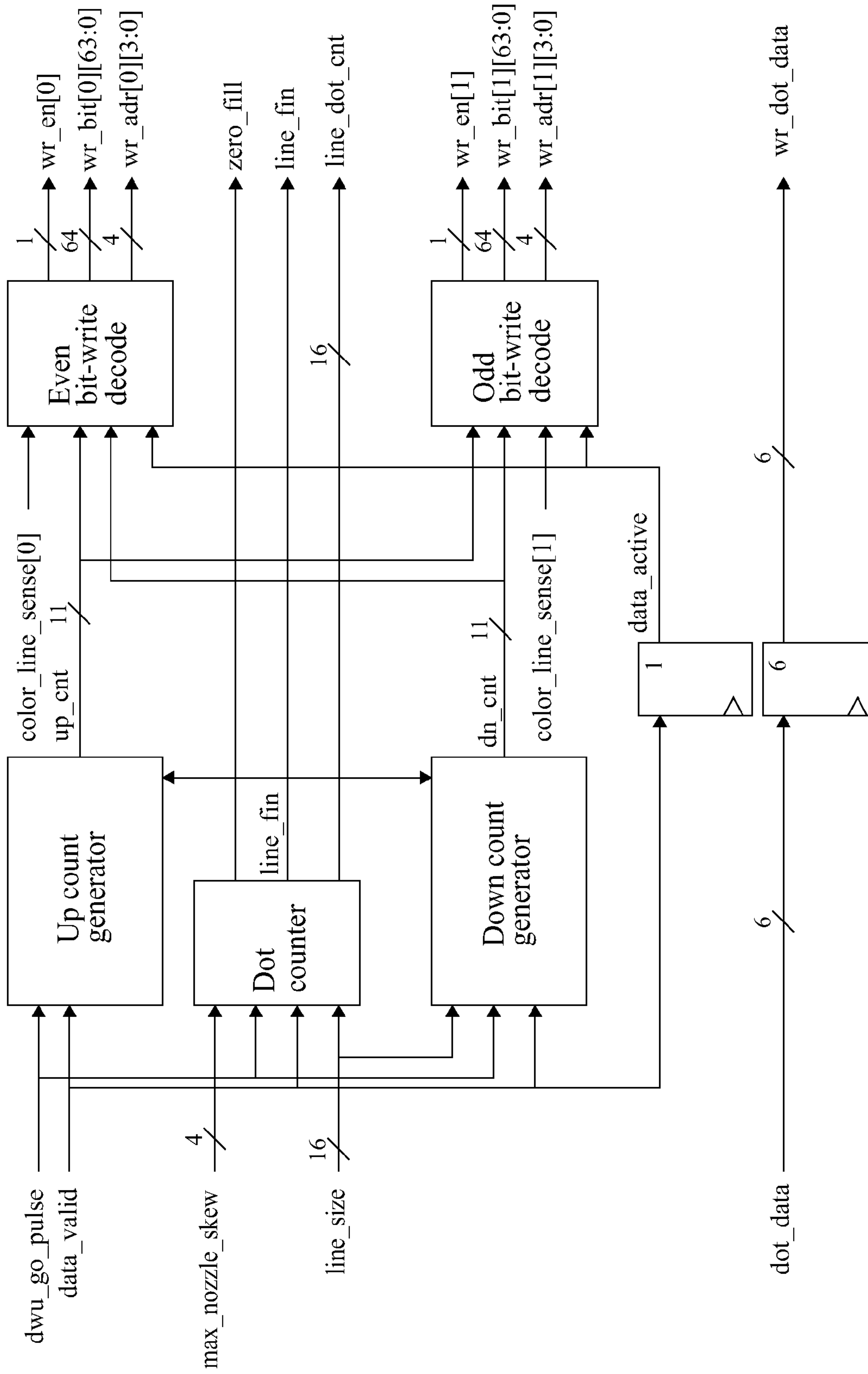

FIG. 29

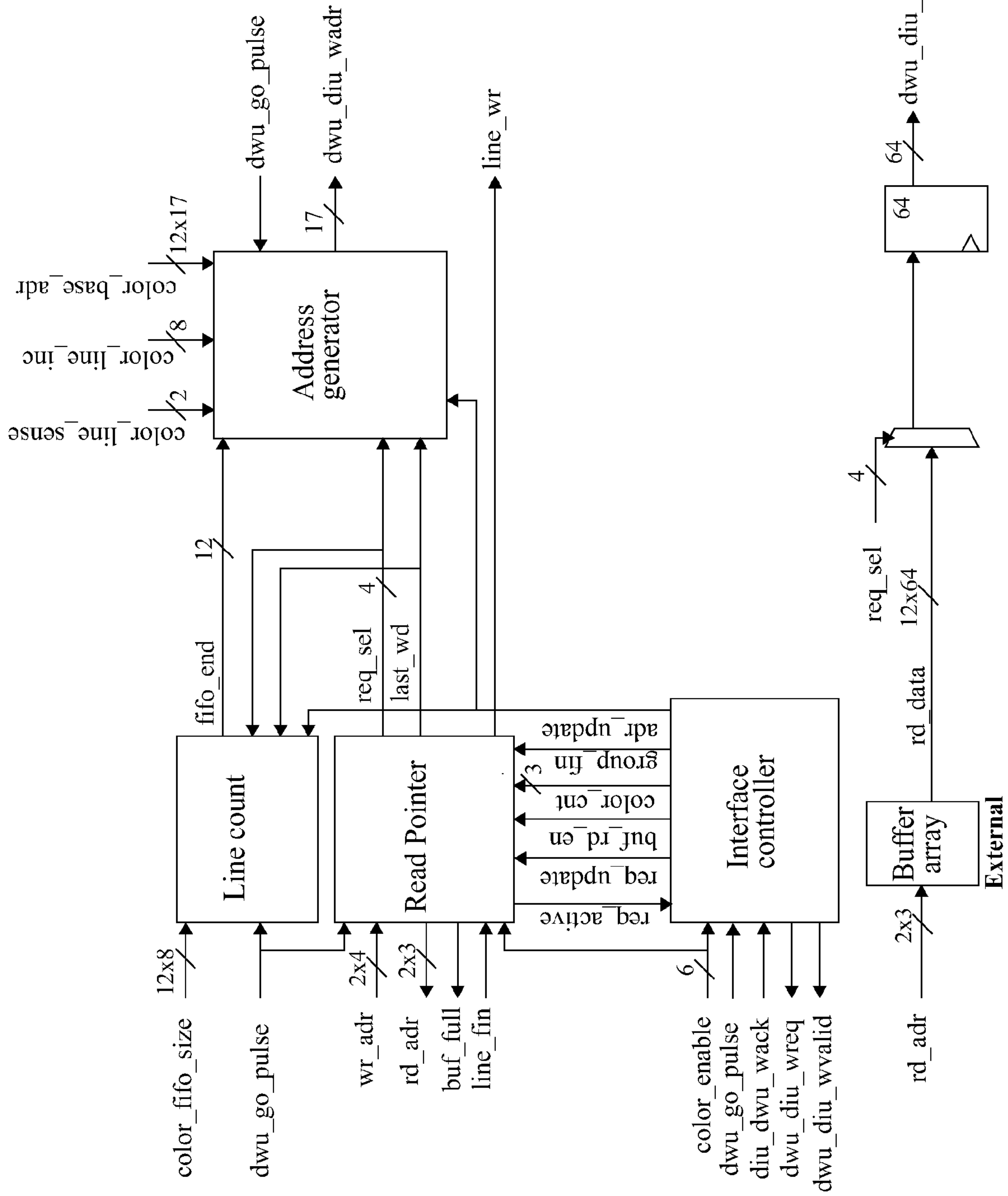

FIG. 30

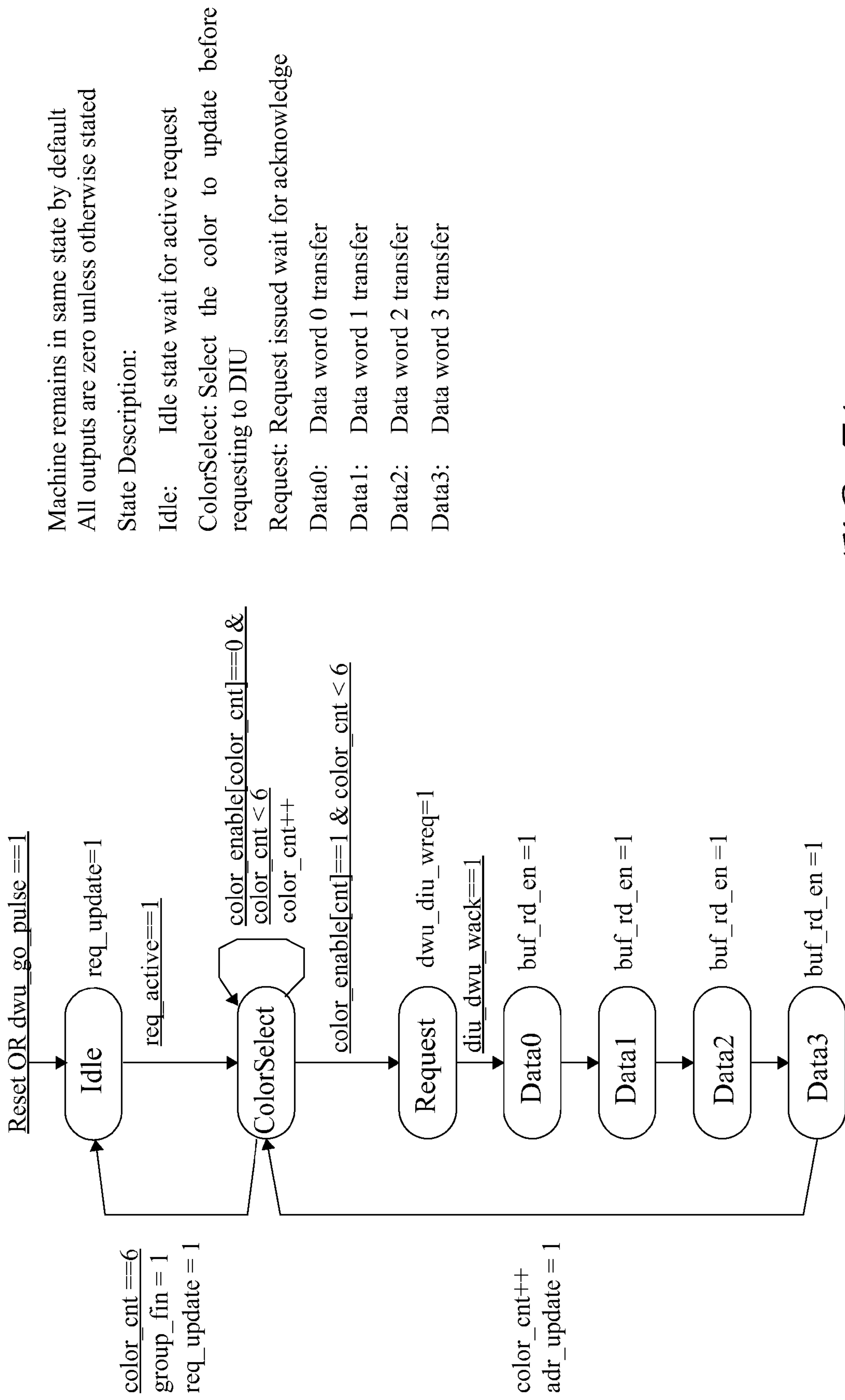

FIG. 31

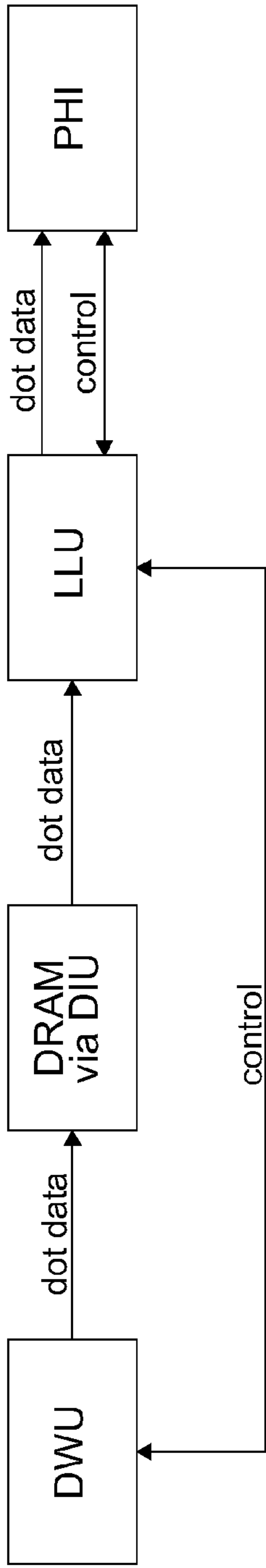

FIG. 32

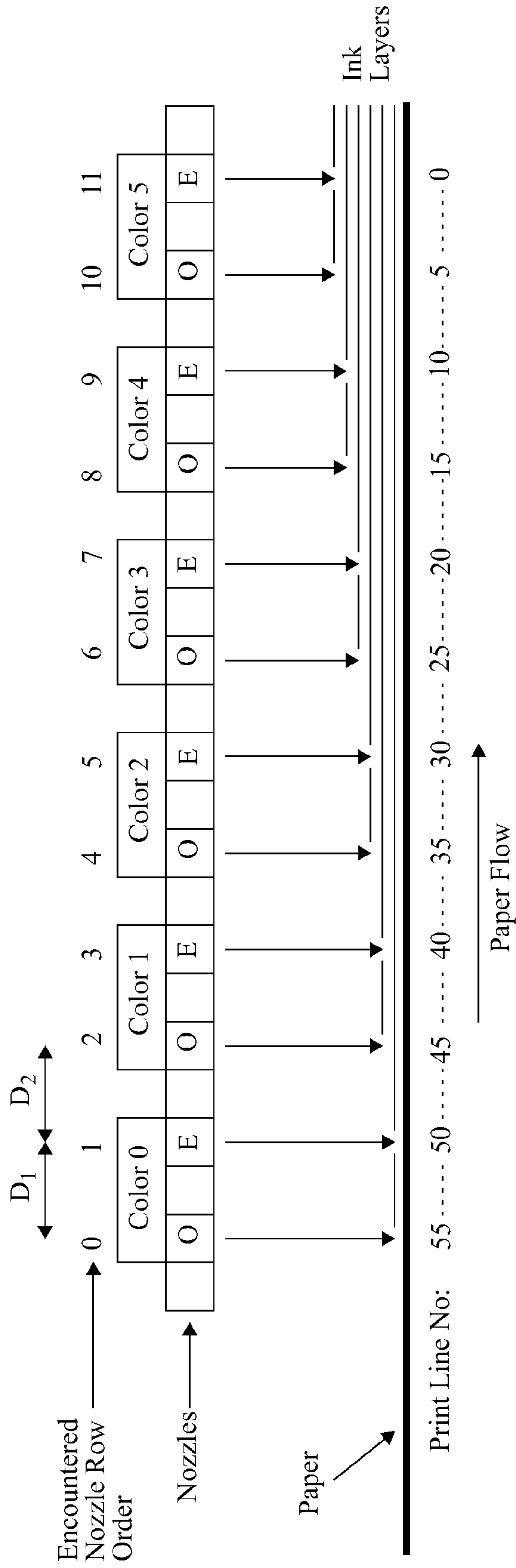
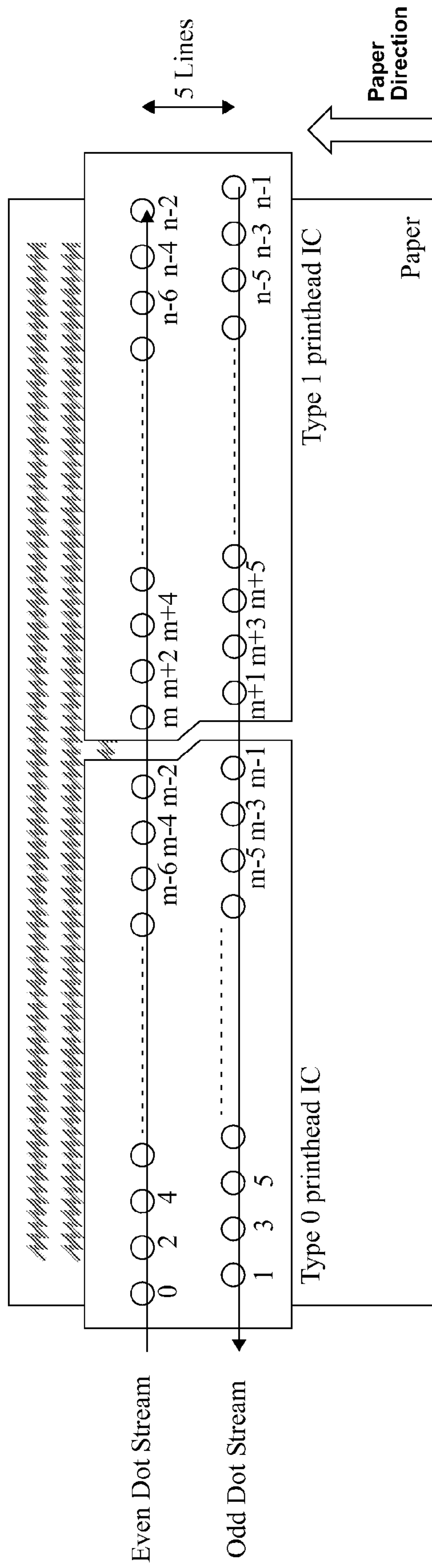

FIG. 33



M - Midway point in dots  
N - Number of dots in a line

Note: Paper passing under printhead

FIG. 34



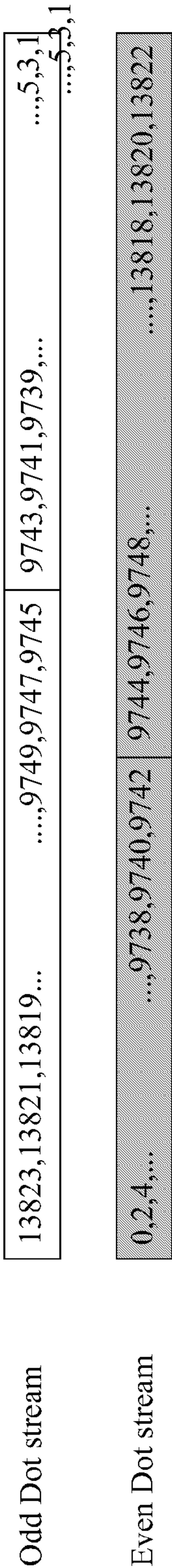

Generate dot order (to the PHI)

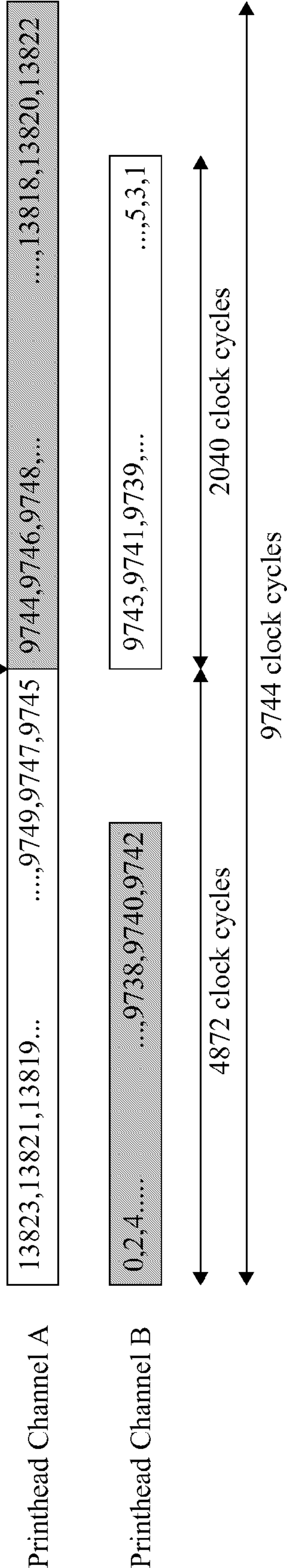

Transmit dot order (to the printhead)

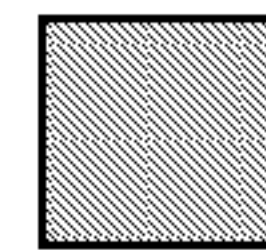

-  Even dots from Line Y
-  Odd dots from Line Y-5

Example: Line with 13824 dots, with 7:3 printhead

FIG. 35

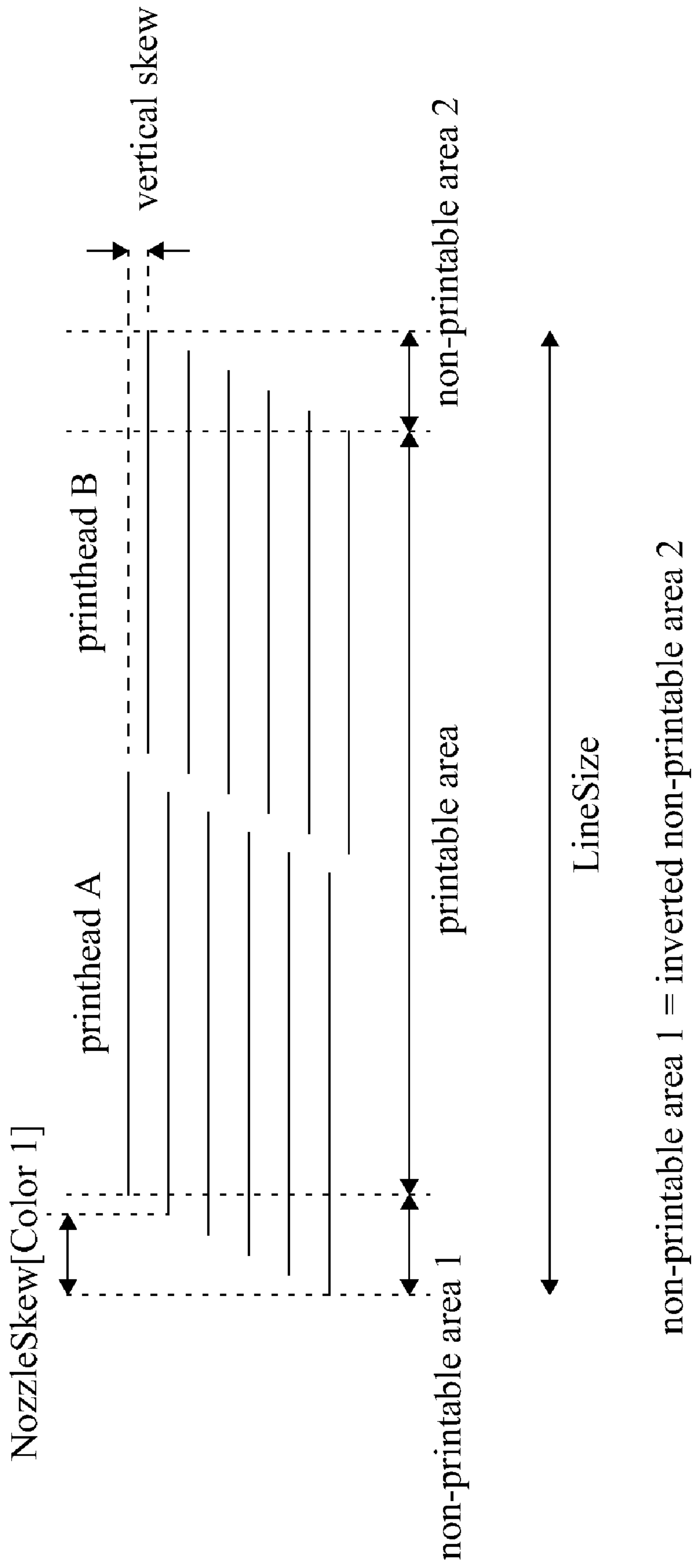

FIG. 36

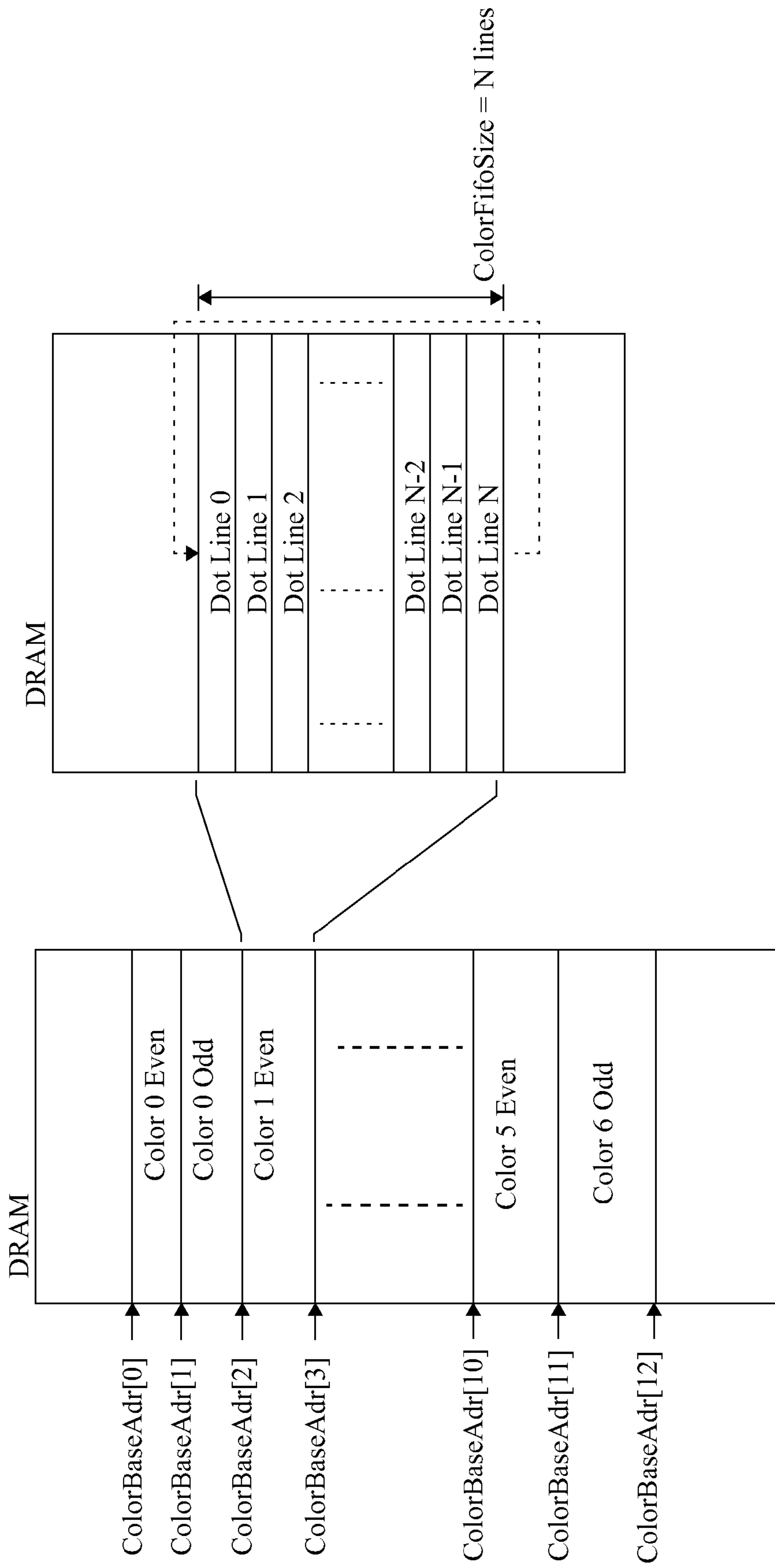

FIG. 37

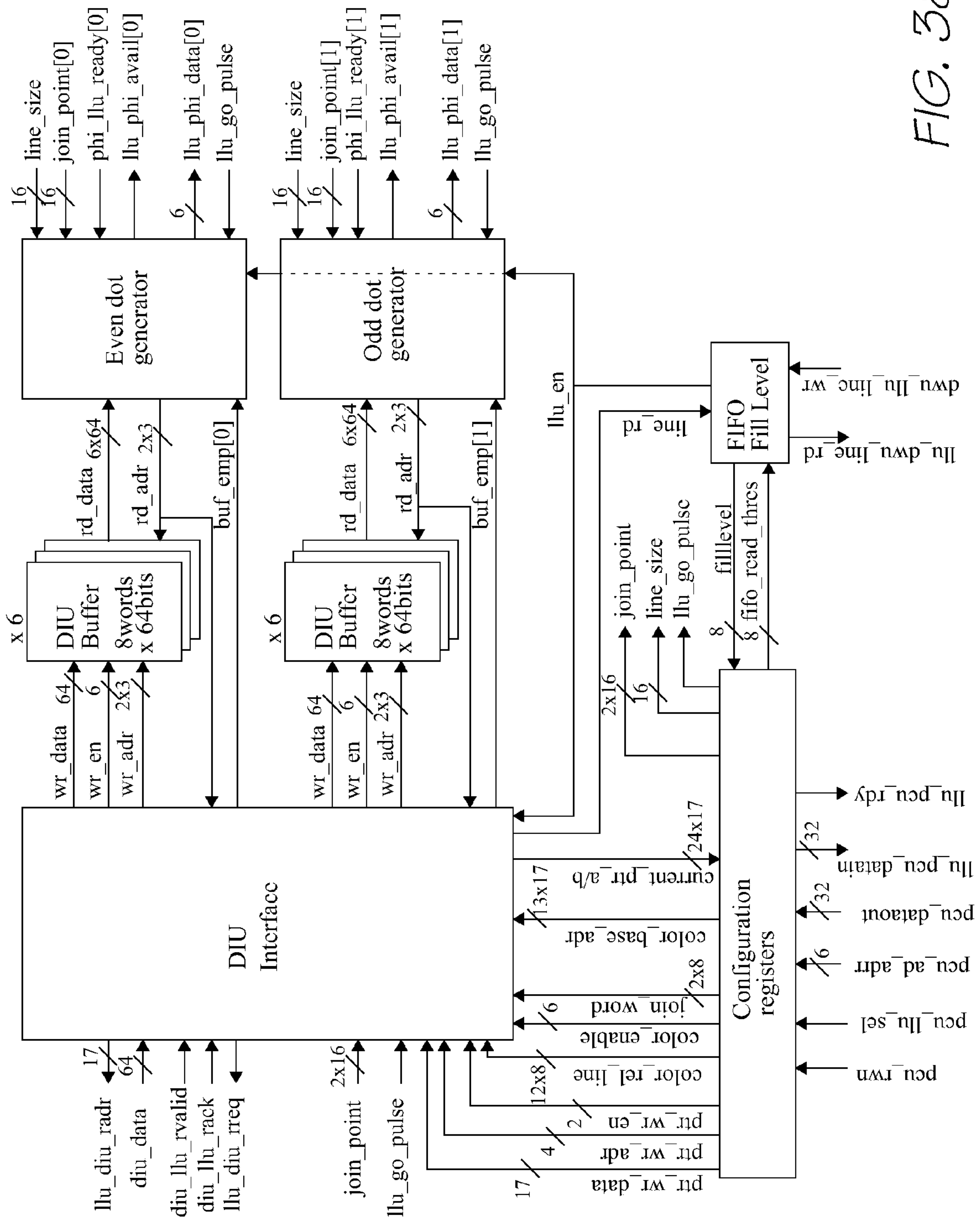

FIG. 38

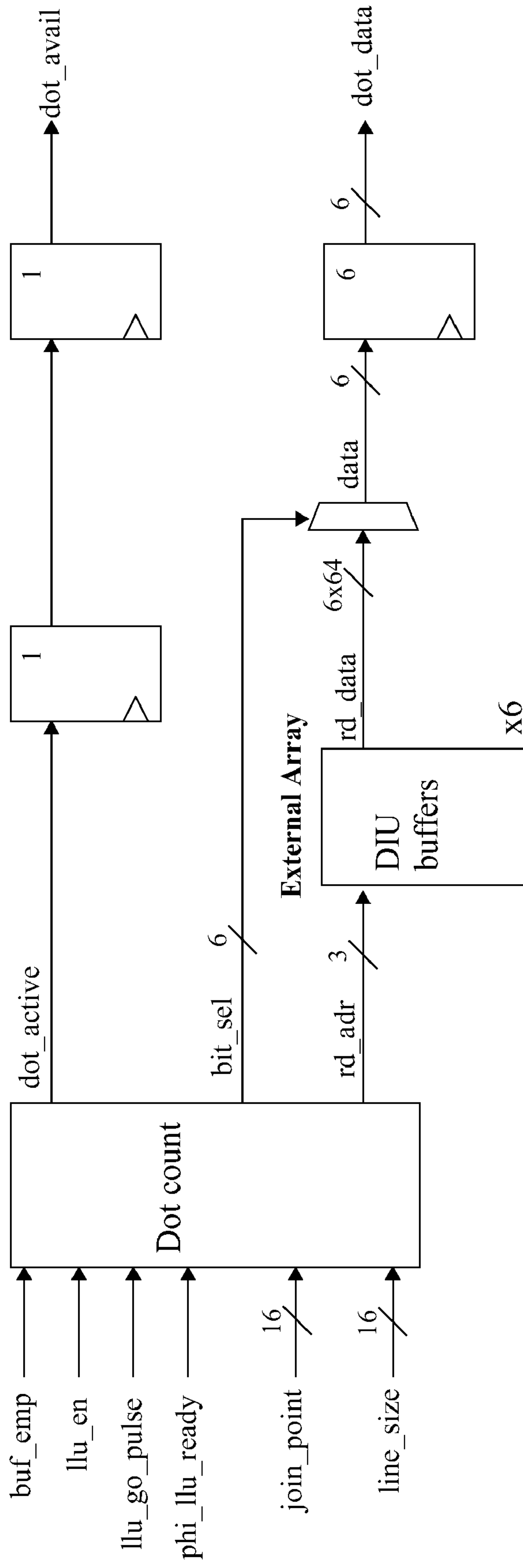

FIG. 39

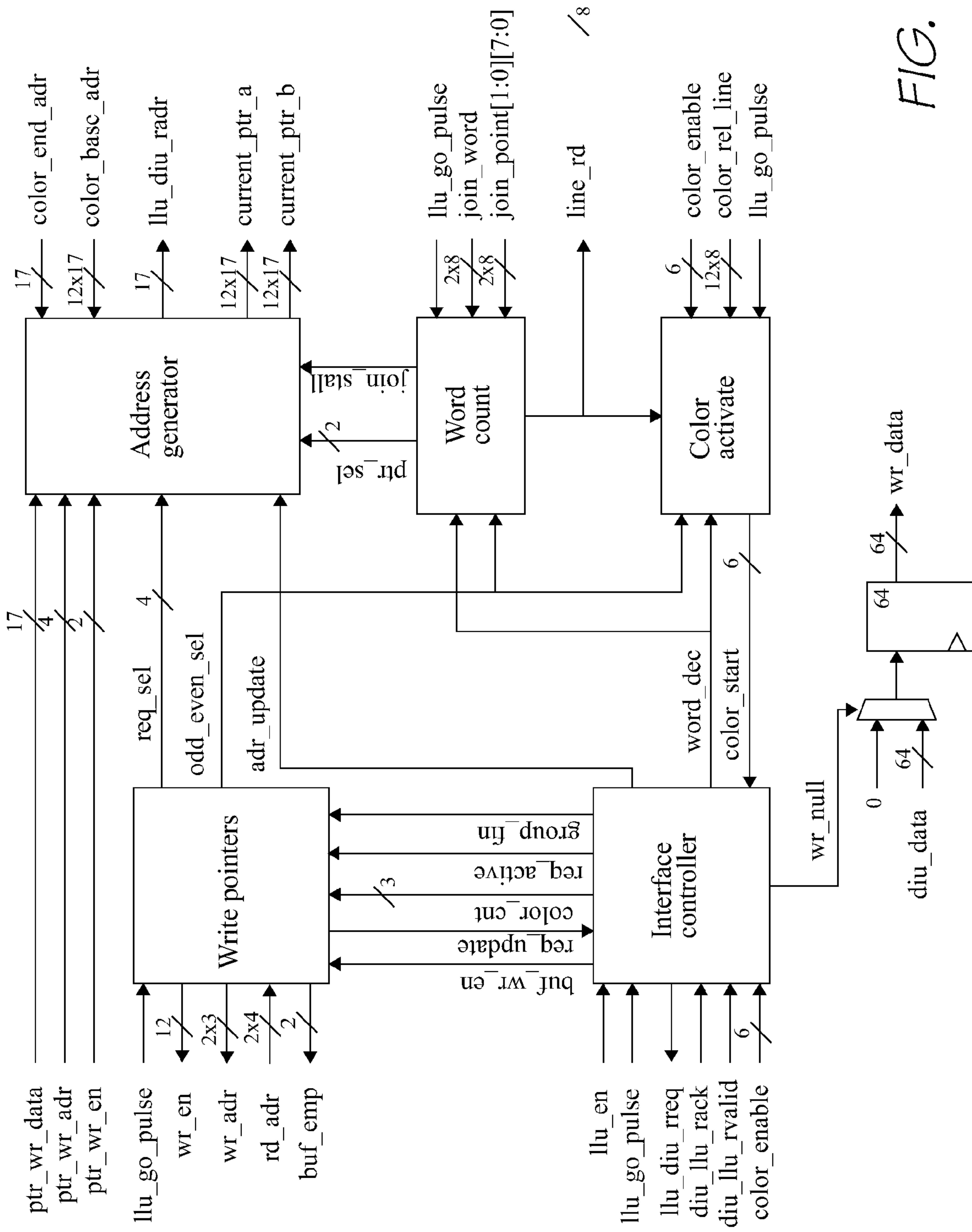
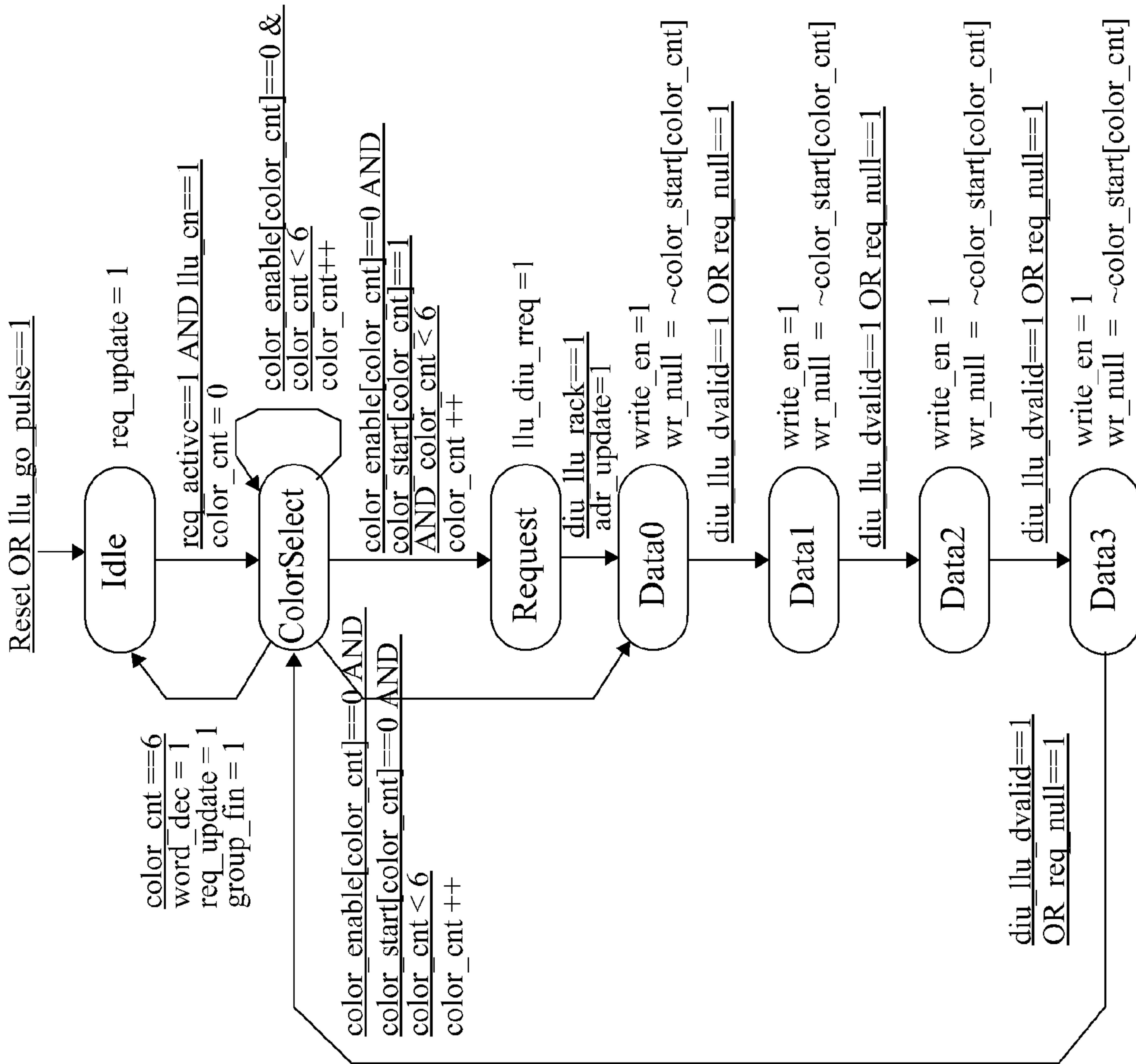

FIG. 40





Machine remains in same state by default  
 All outputs are zero unless otherwise stated

State Description:

Idle: Idle state wait for active request

ColorSelect: Select the color to update before requesting to DIU

Request: Request issued wait for acknowledge

Data0: Data word 0 transfer

Data1: Data word 1 transfer

Data2: Data word 2 transfer

Data3: Data word 3 transfer

FIG. 41

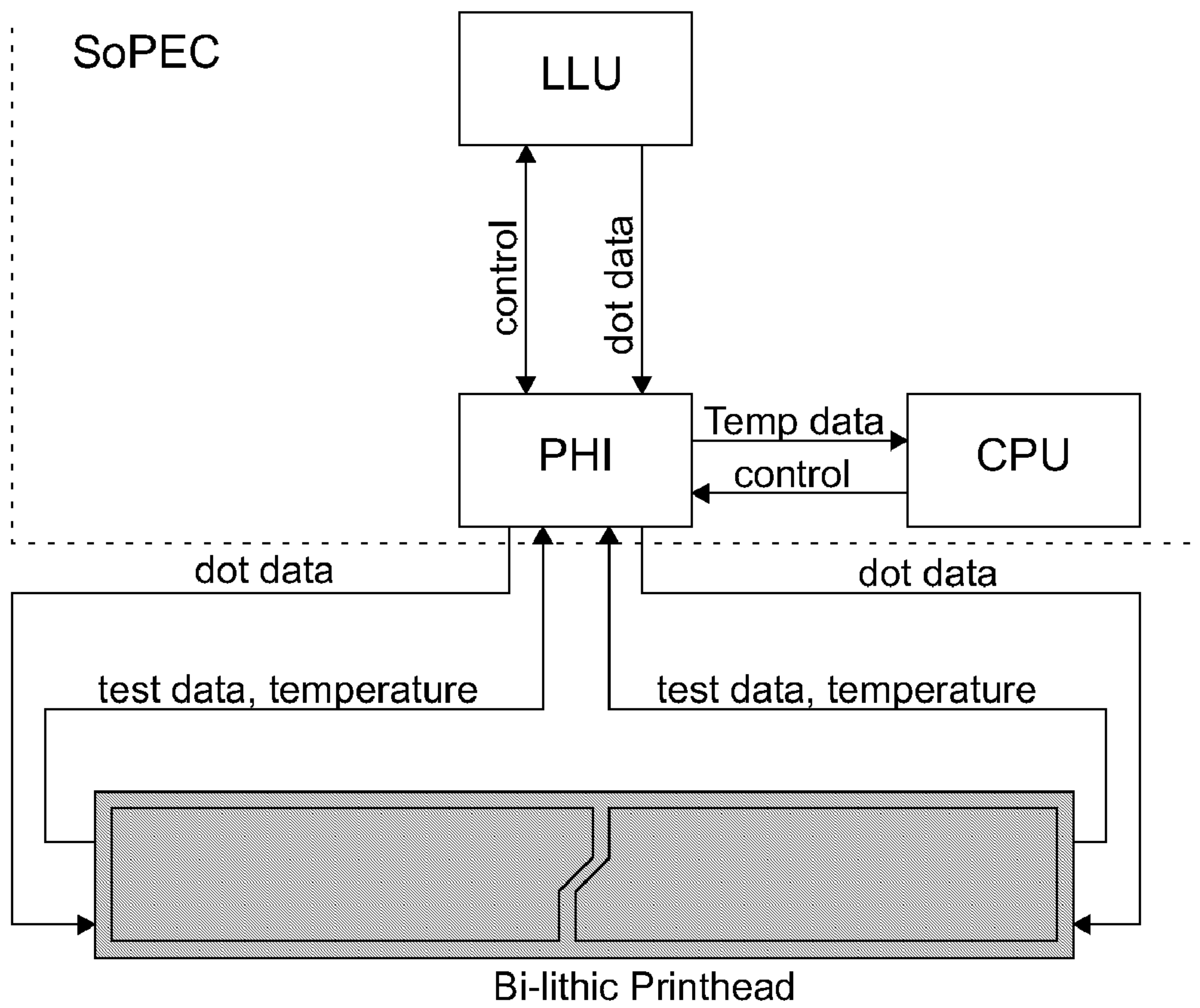

FIG. 42

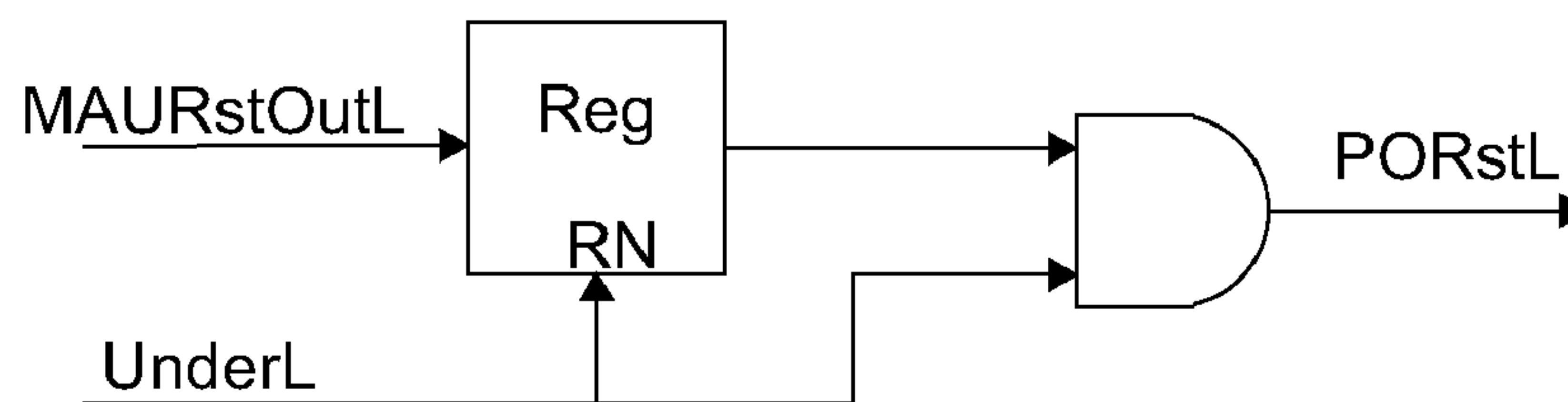
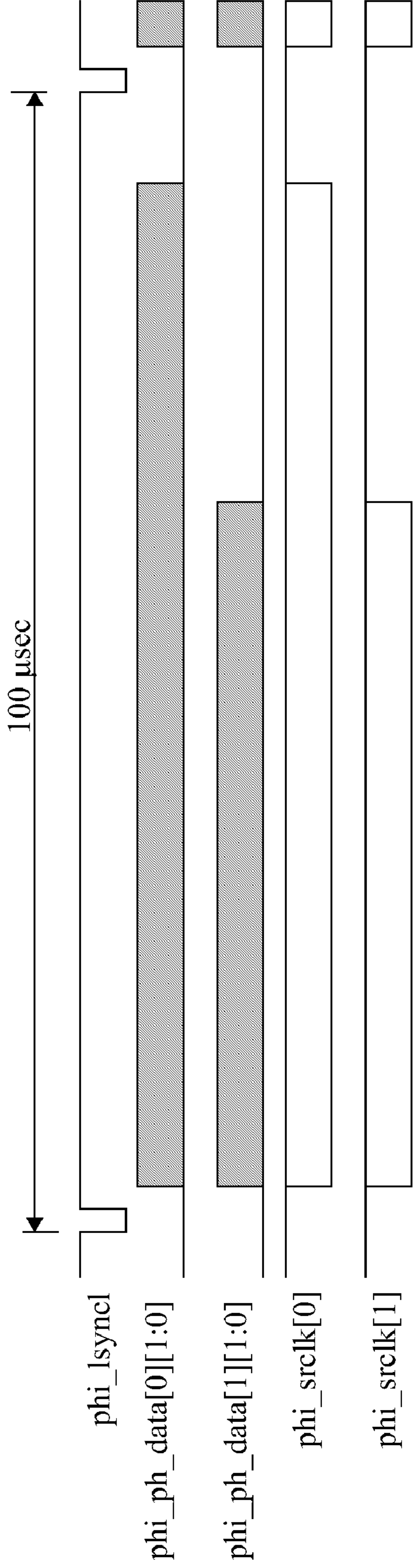
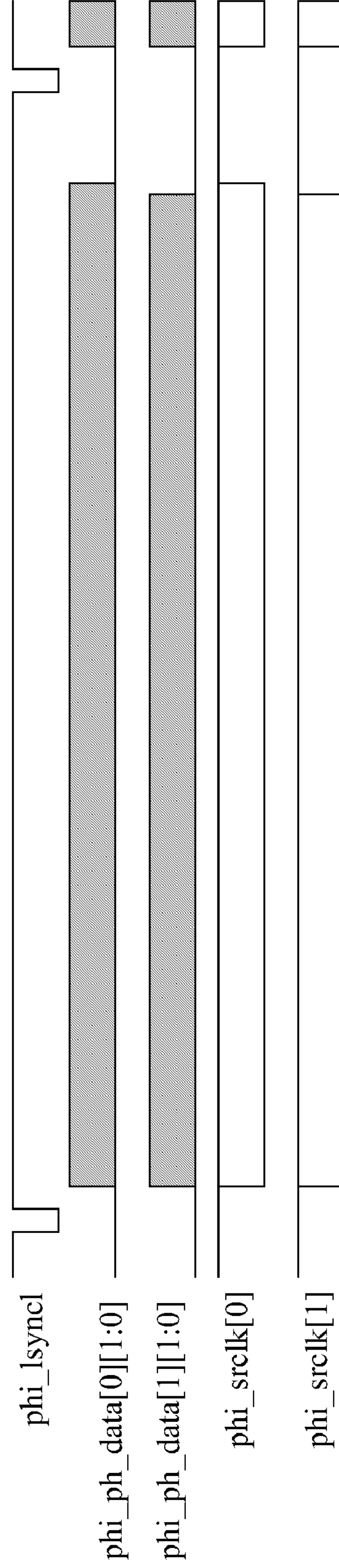

FIG. 43

**Without Rate equalization (7:3 head)**



**With Rate equalization (7:3 head)**



*FIG. 44*



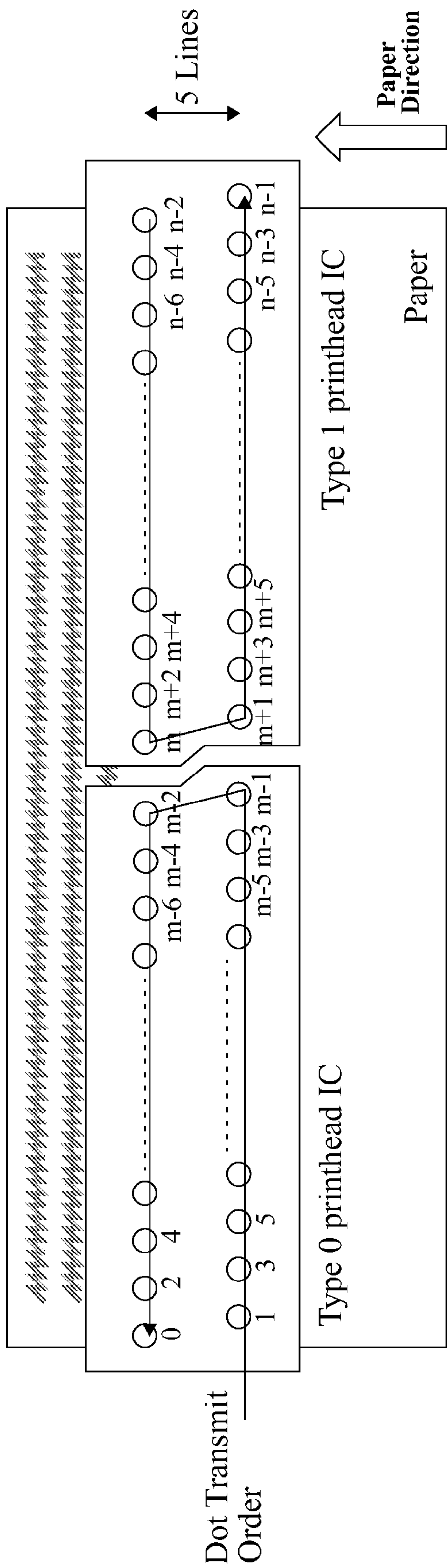

Note: Paper passing under printhead

M - Midway point in dots  
N - Number of dots in a line

FIG. 45

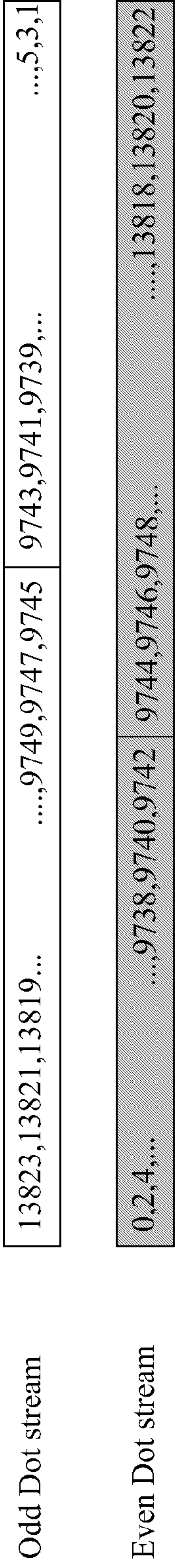

Generate dot order (from the LLU)

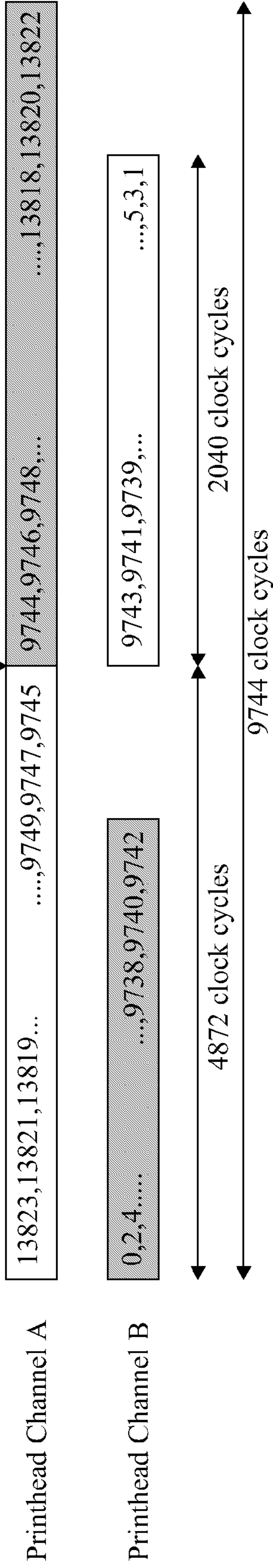

Mid Point

Transmit dot order(to the printhead)

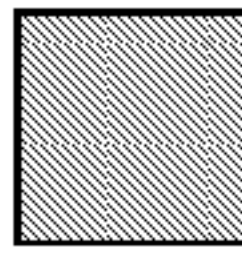

-  Even dots from Line Y
-  Odd dots from Line Y-5

Example: Line with 13824 dots, with 7:3 printhead

FIG. 46

Generate dot order (from the LLU)

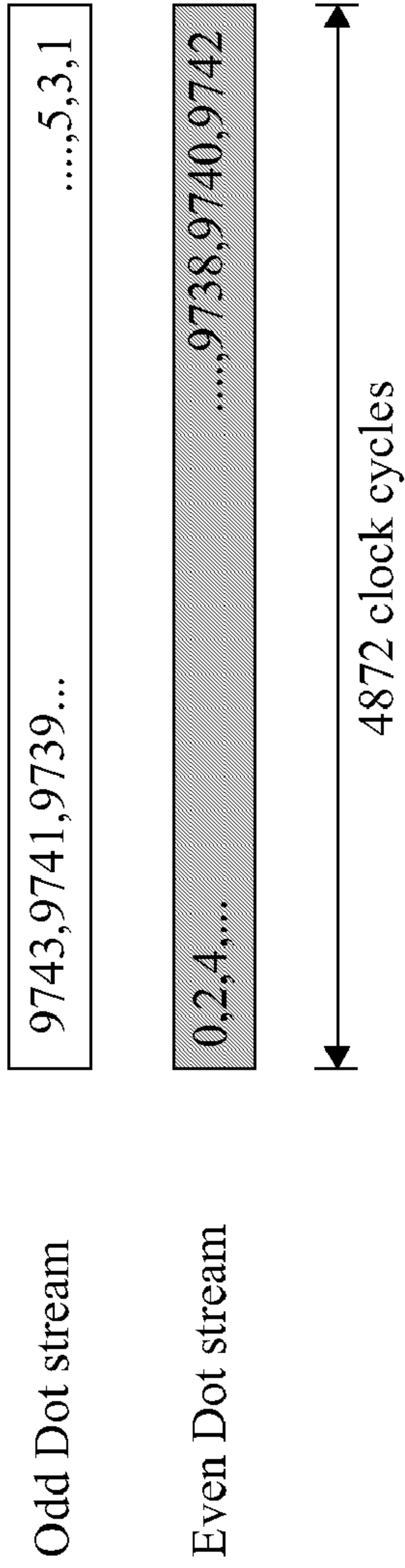

Transmit dot order(to the printhead)

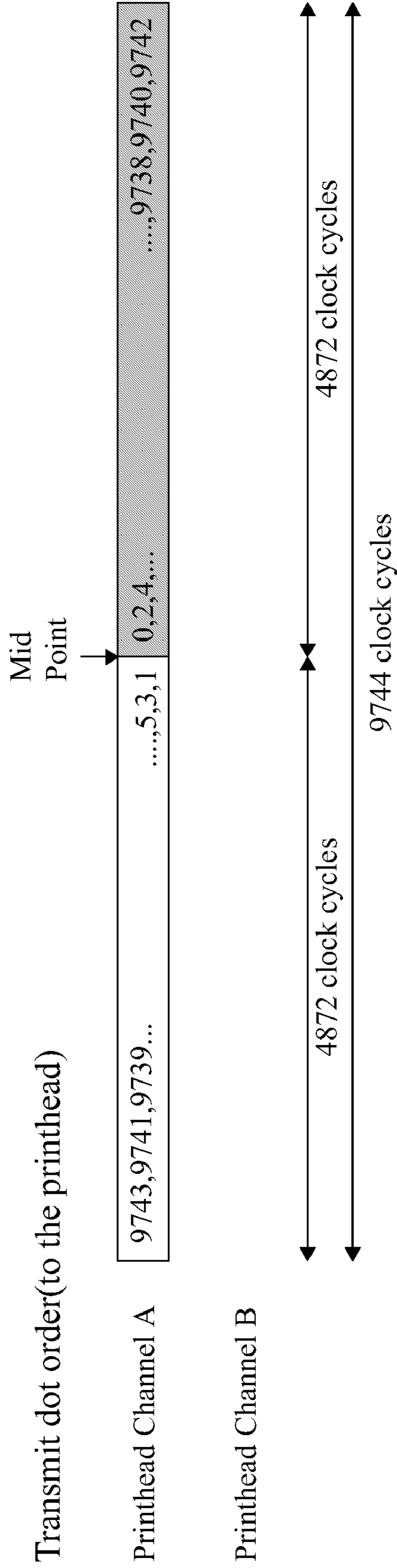

- Even dots from Line Y
- Odd dots from Line Y-5

Example: Line with 9744 dots, with 7:0 printhead

FIG. 47

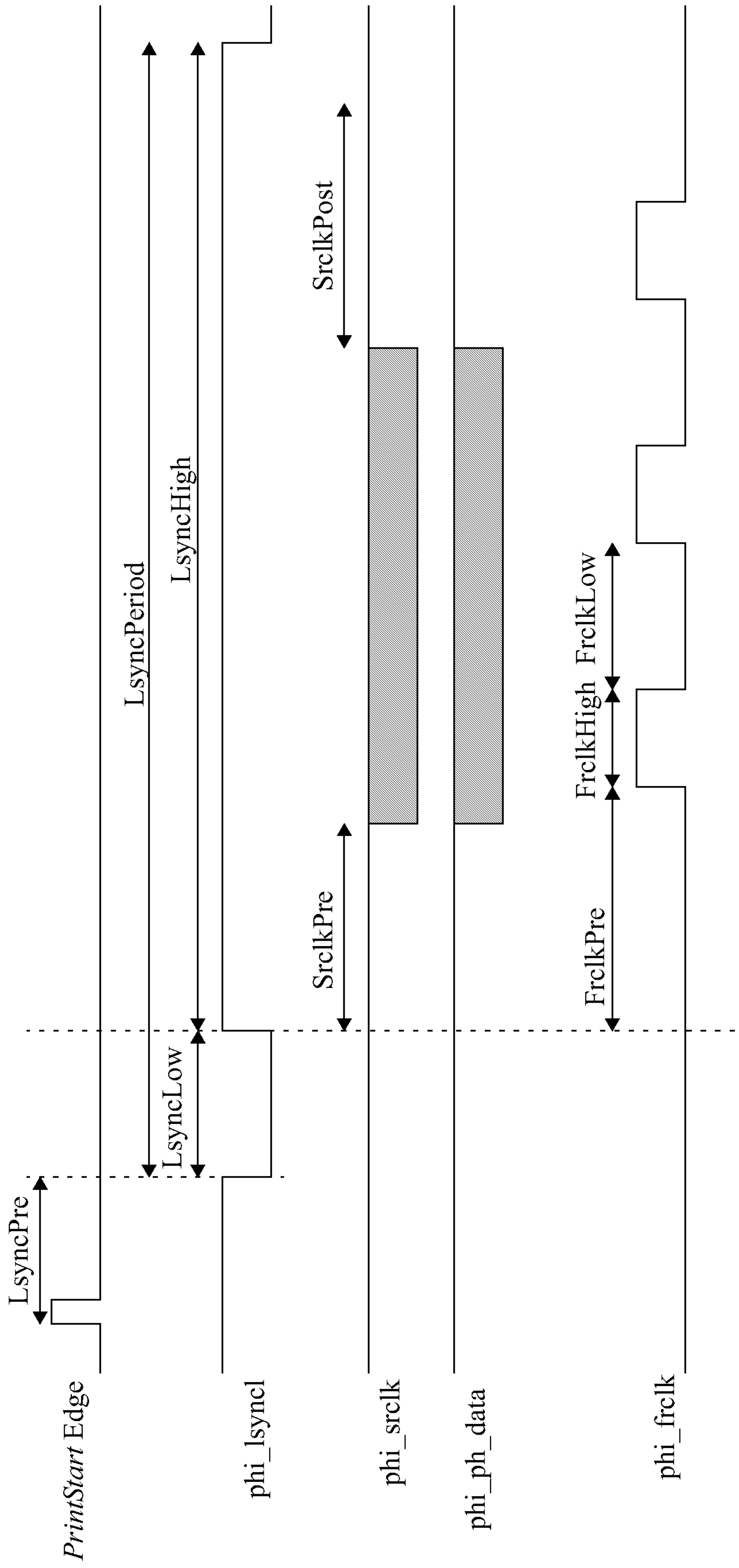

FIG. 48



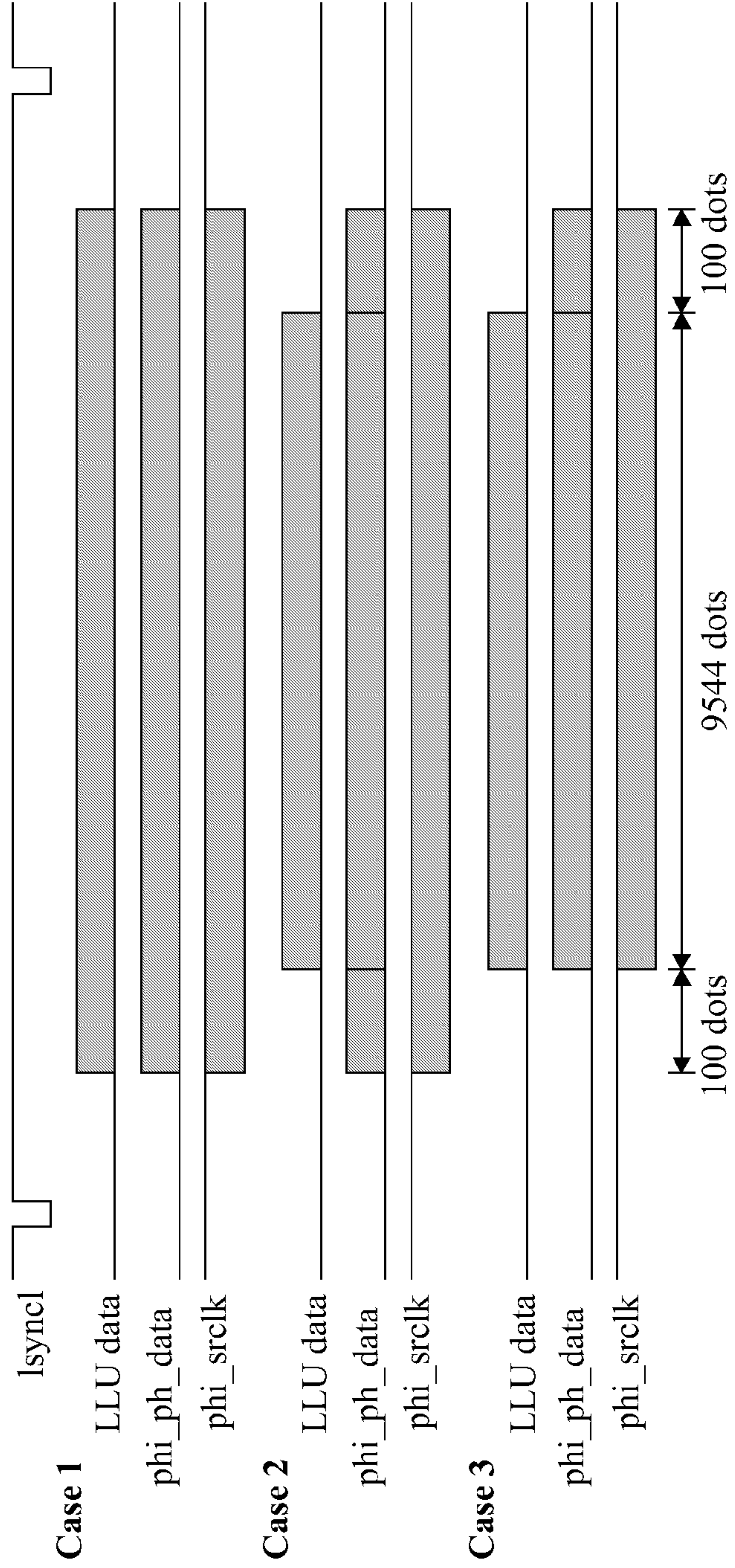
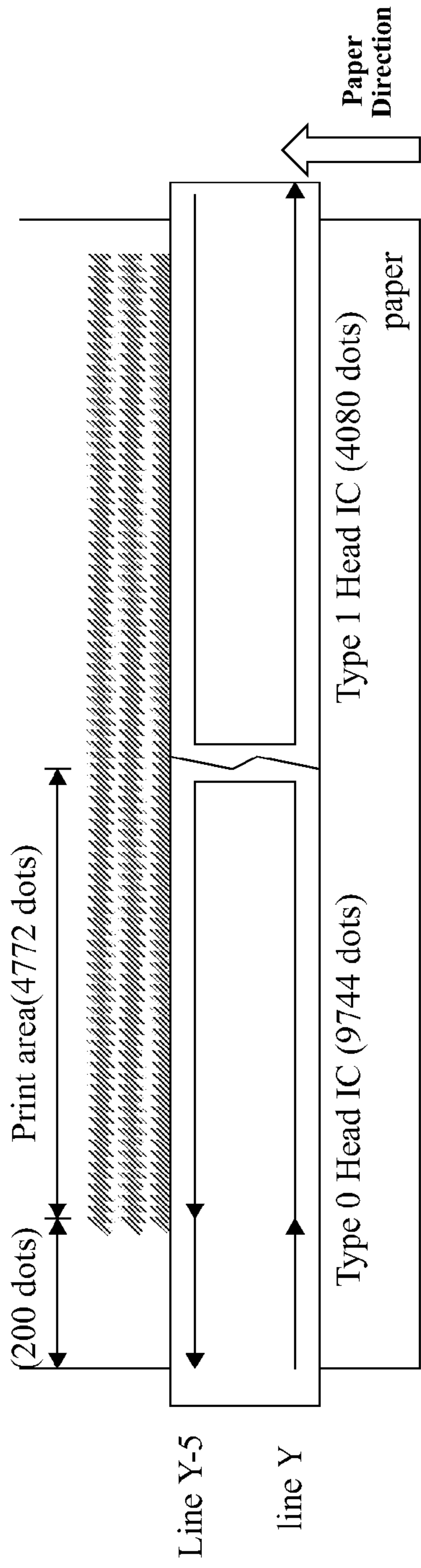

FIG. 49

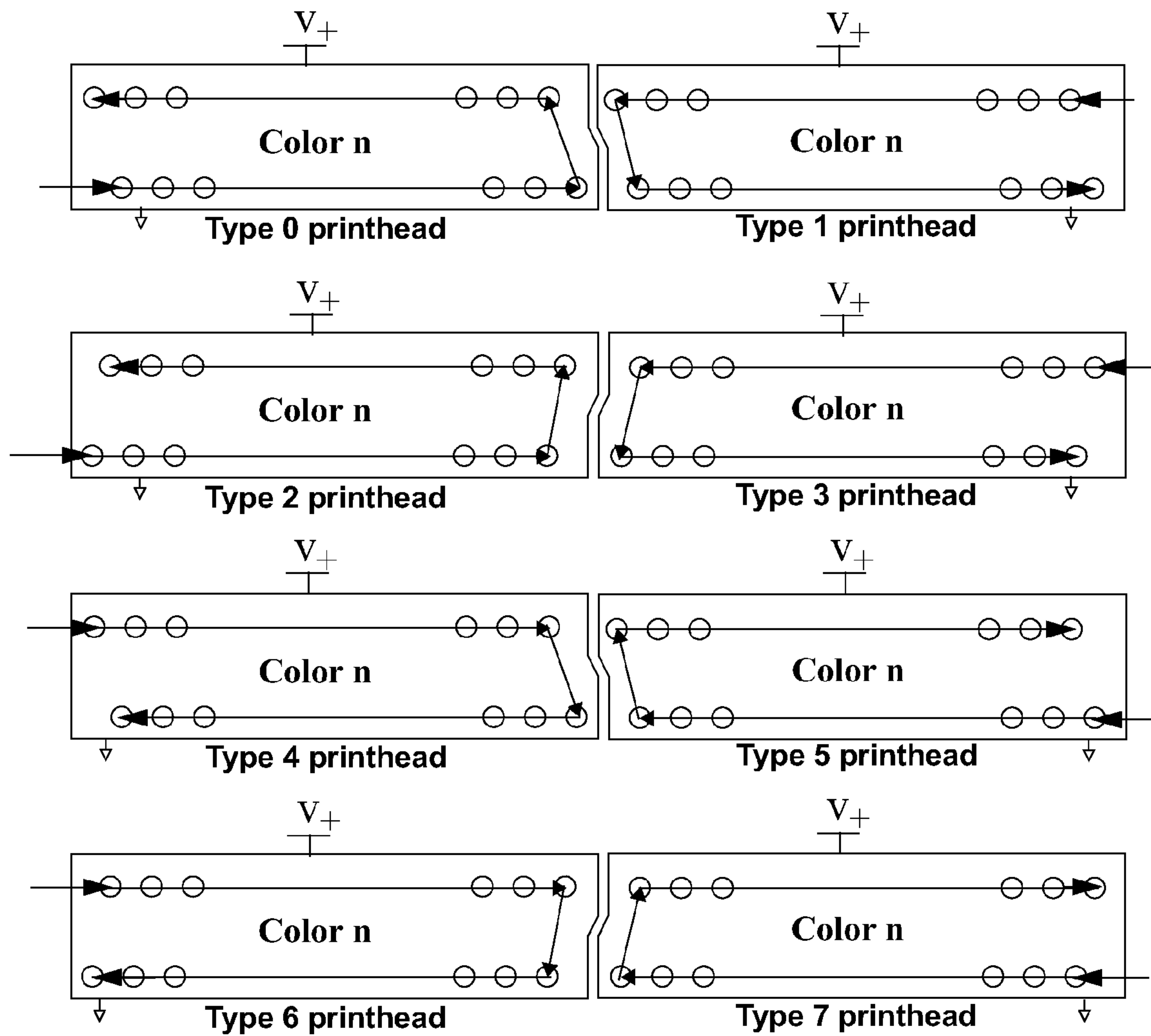

FIG. 50

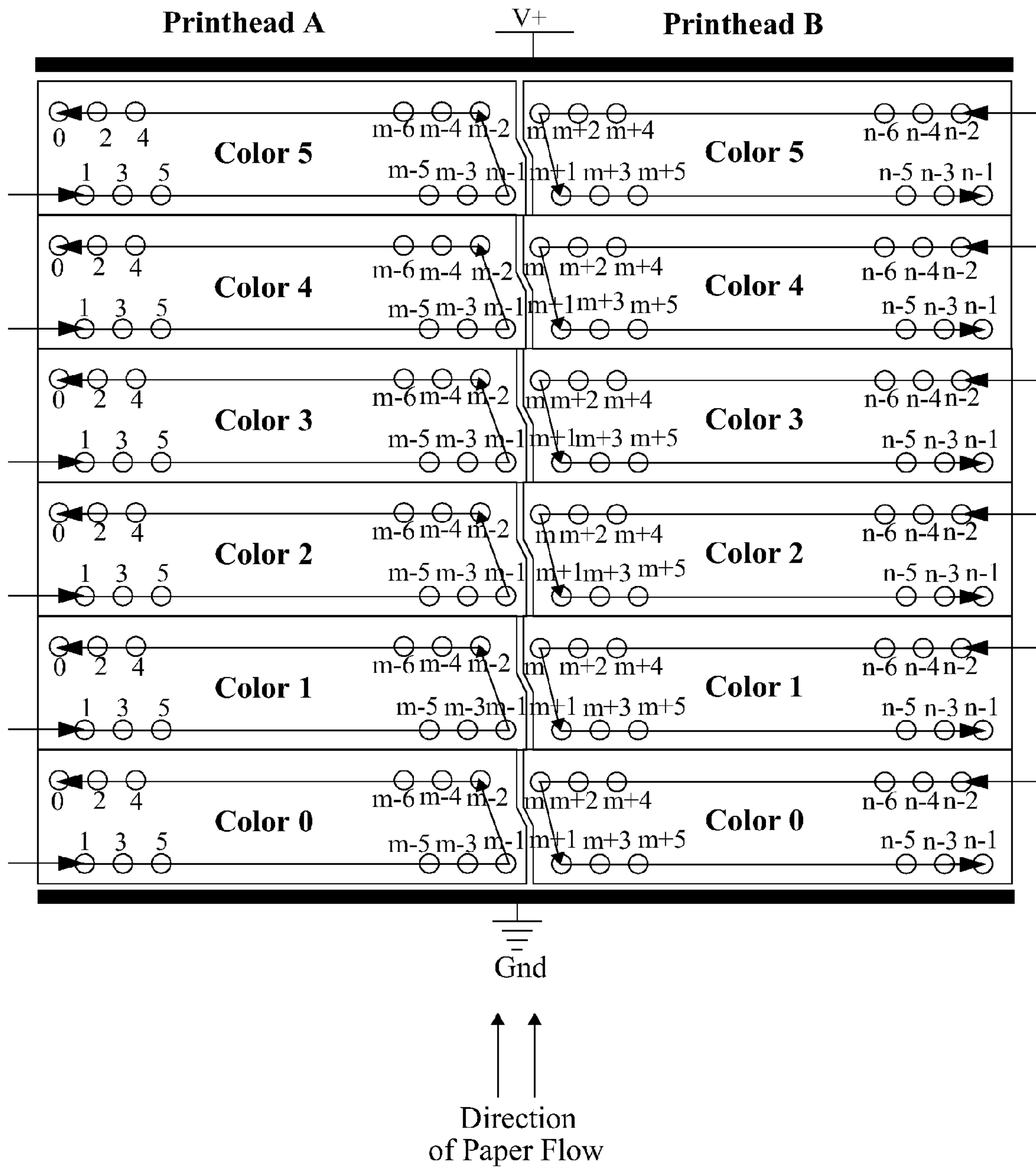

FIG. 51



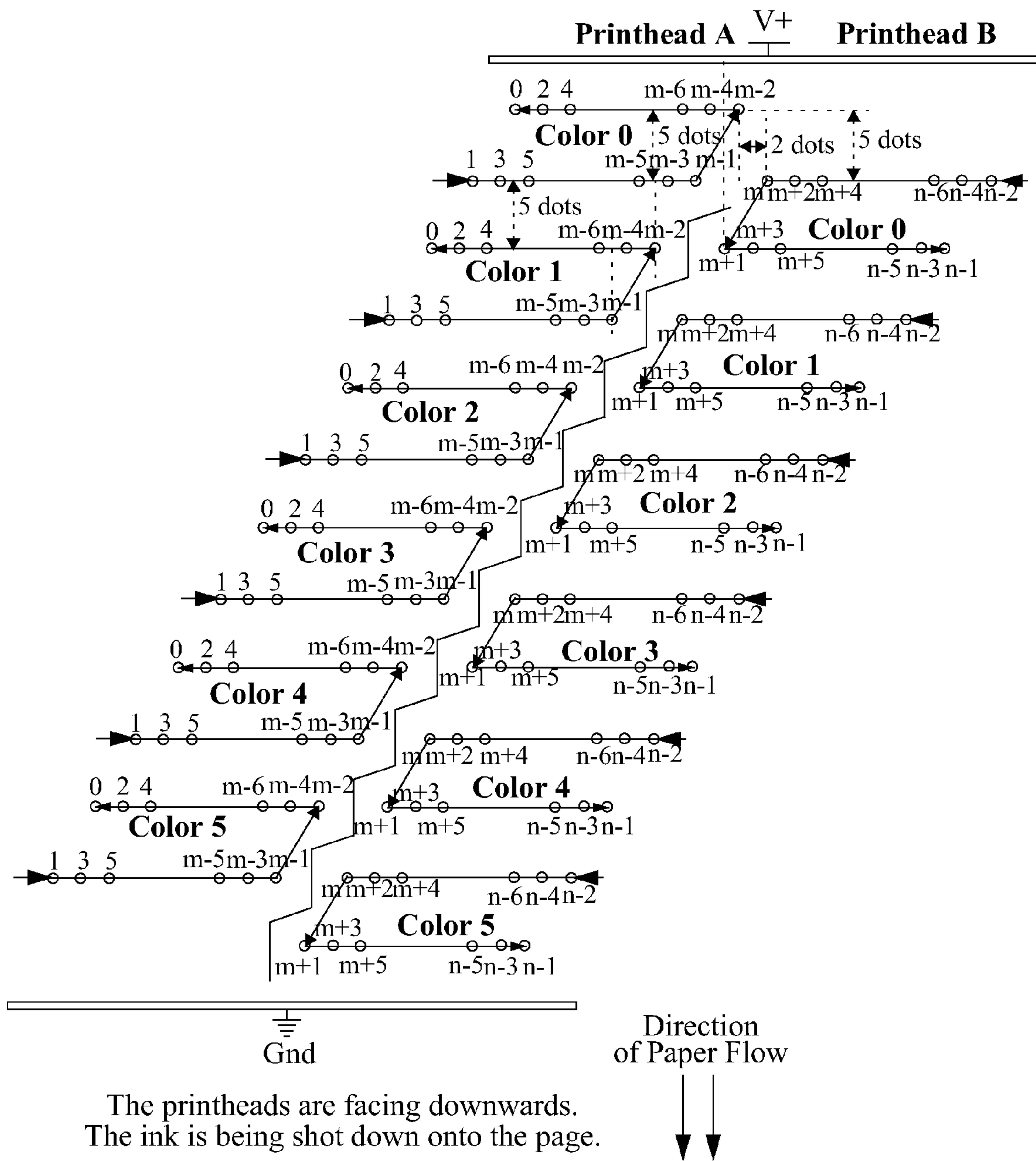

FIG. 52

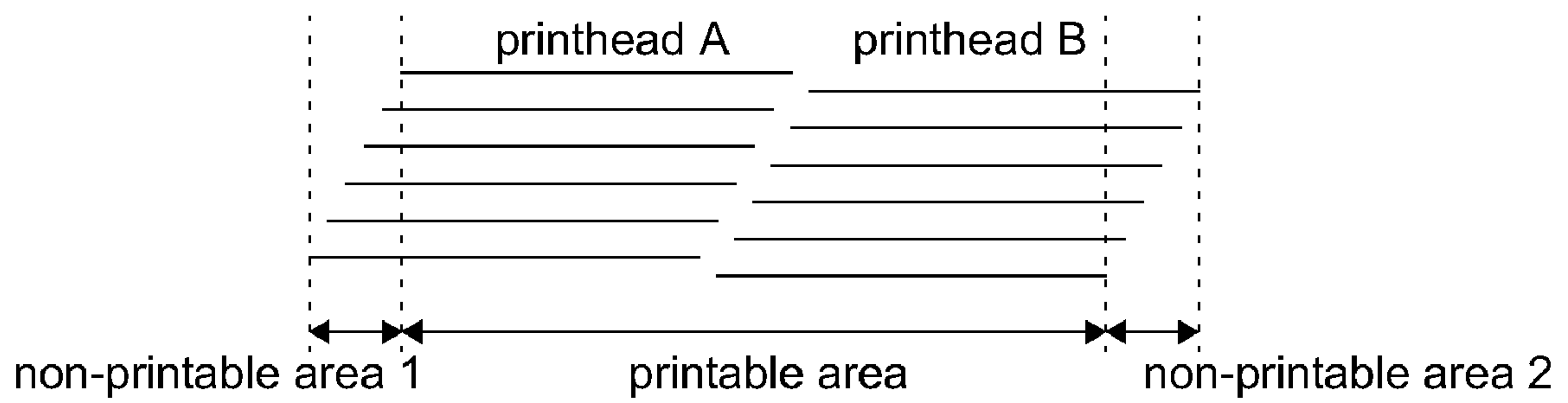

FIG. 53

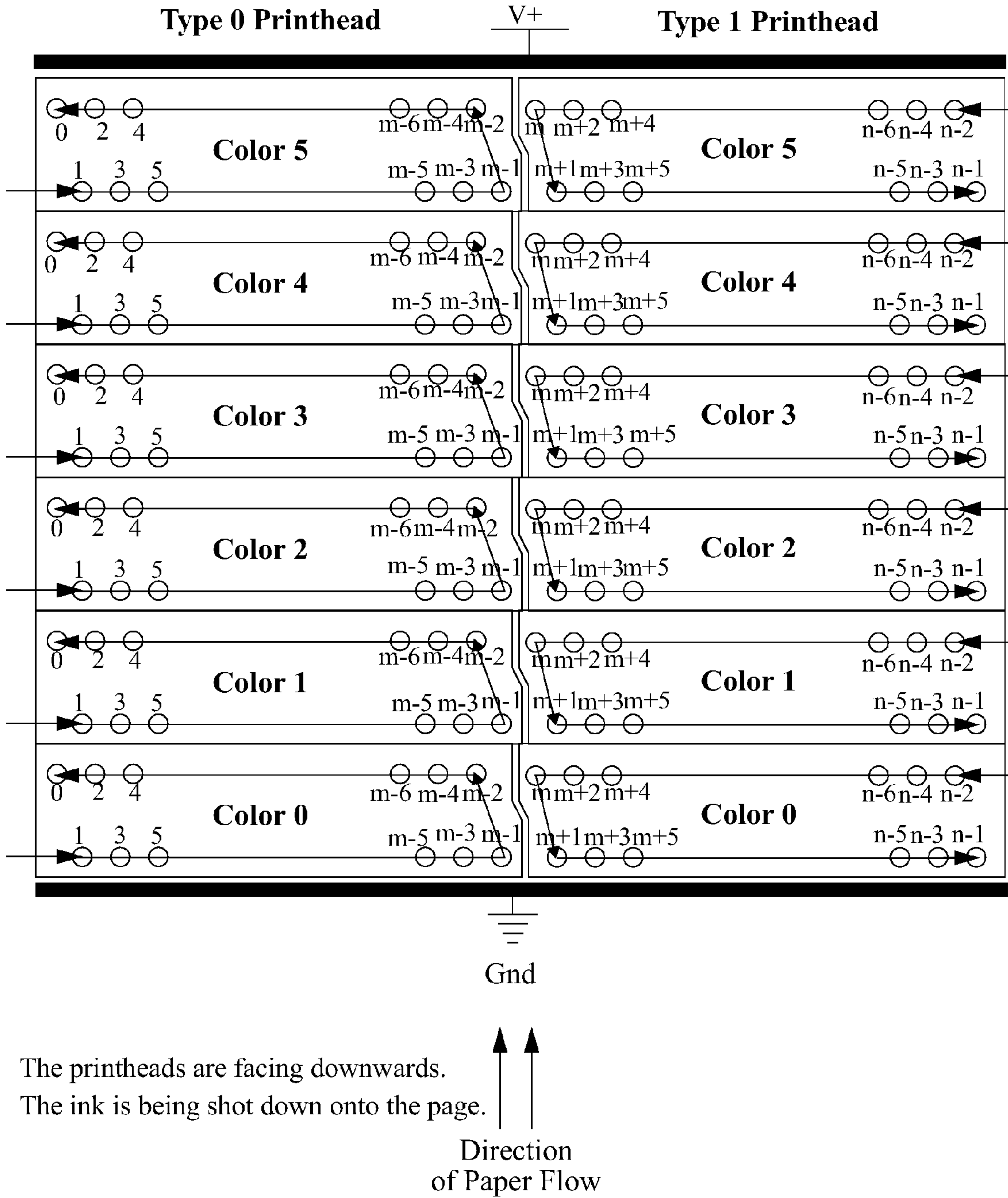

FIG. 54



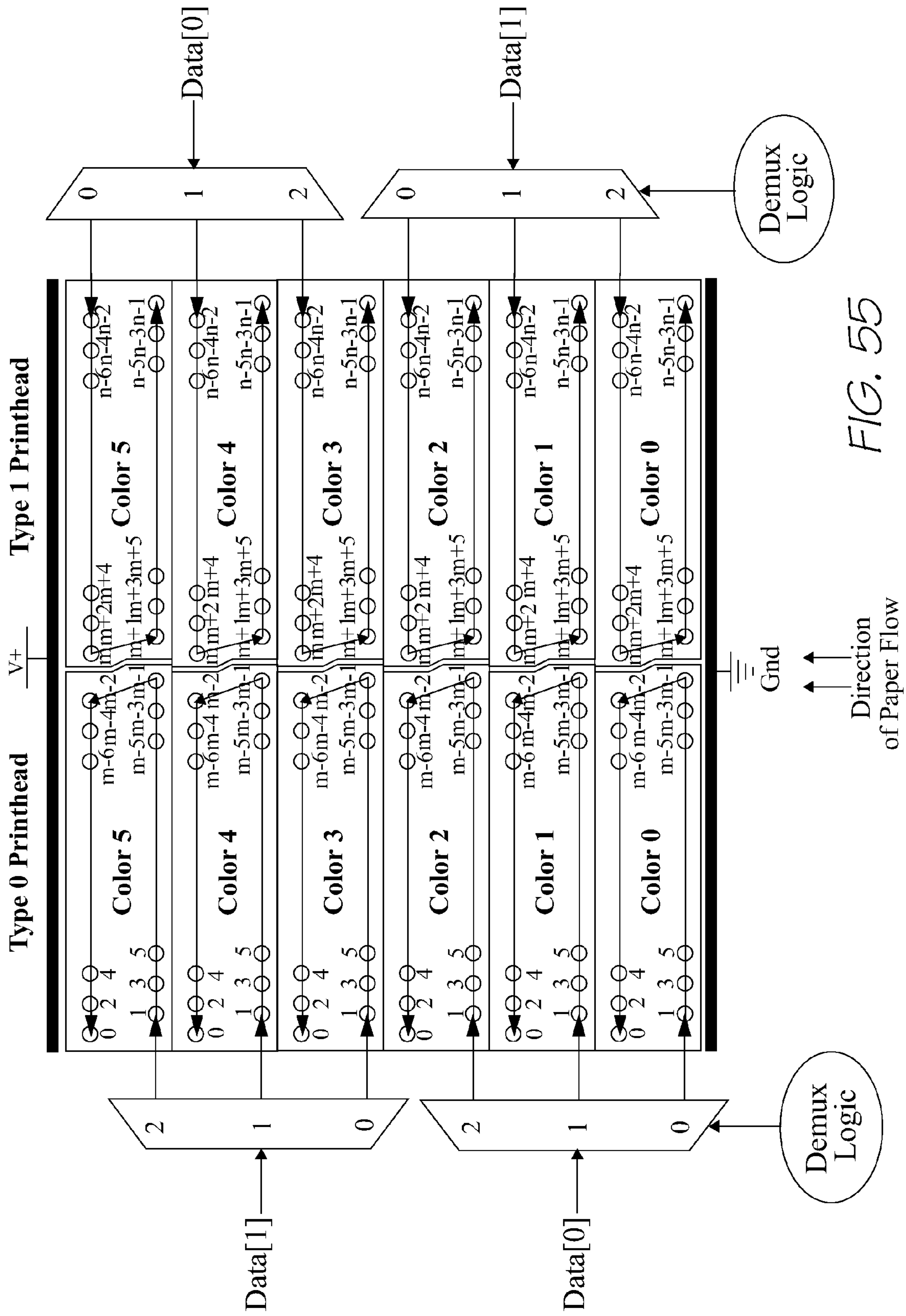

FIG. 55

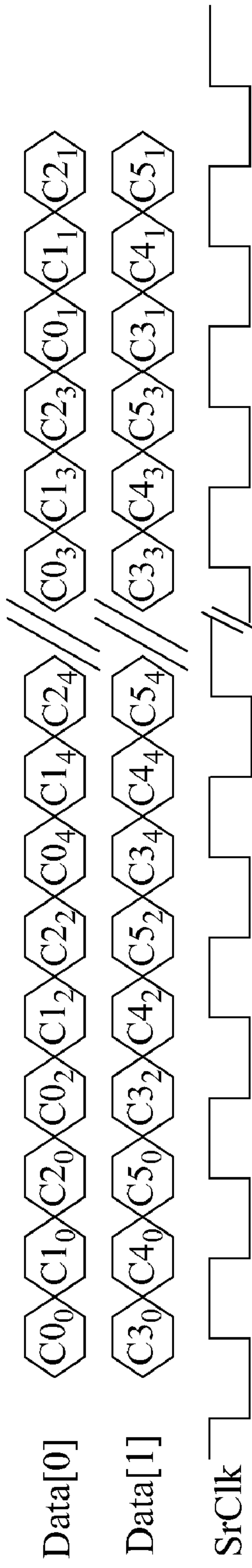

FIG. 56

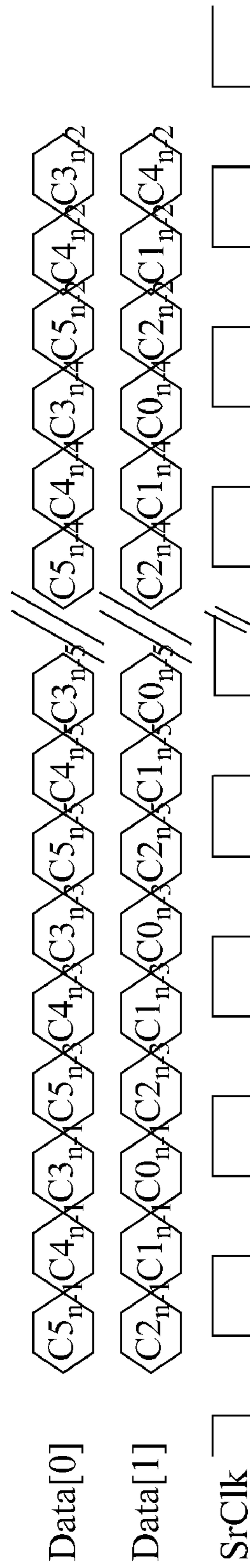

FIG. 57

The printheads are facing downwards.  
The ink is being shot down onto the page.

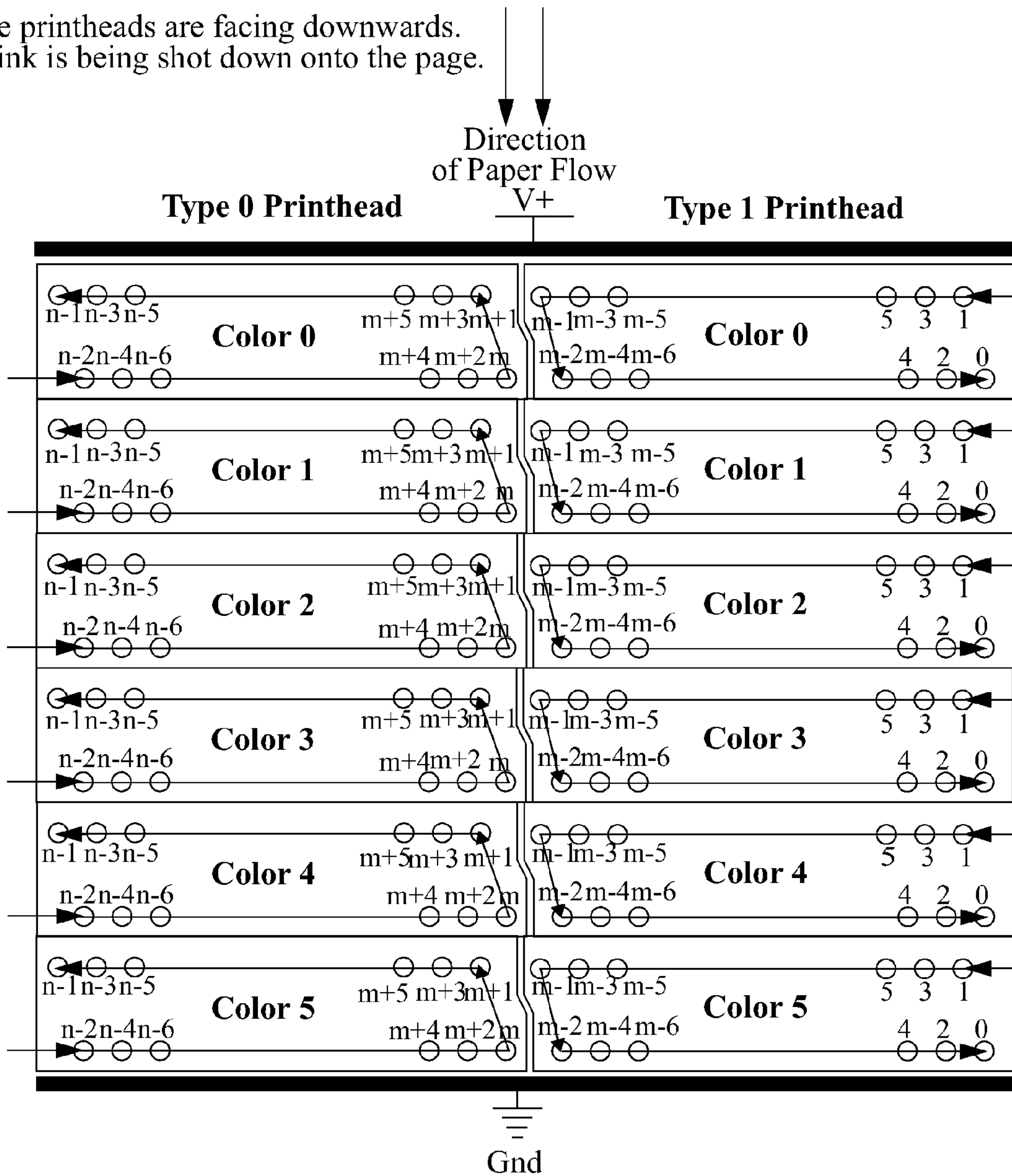

FIG. 58

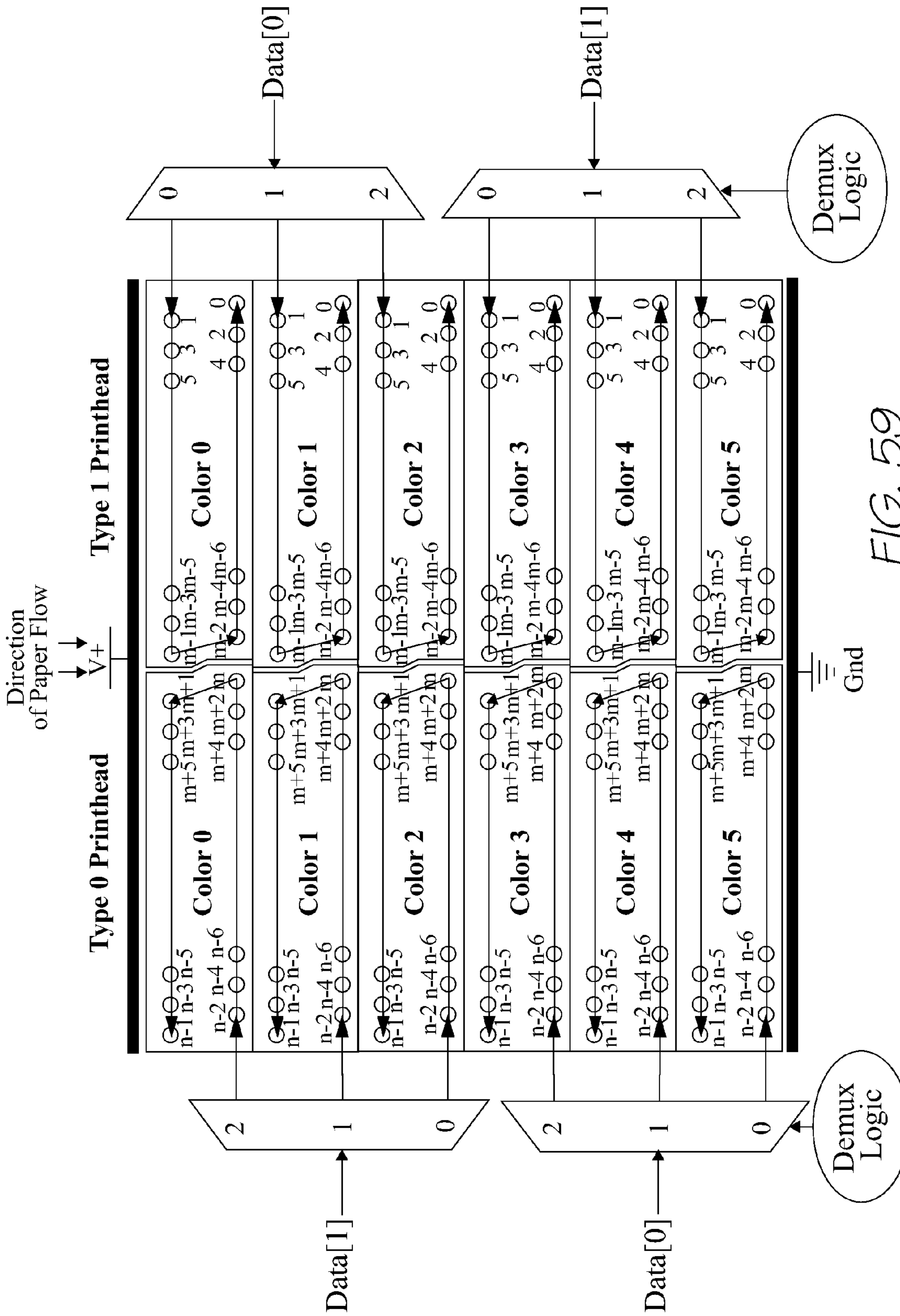

FIG. 59



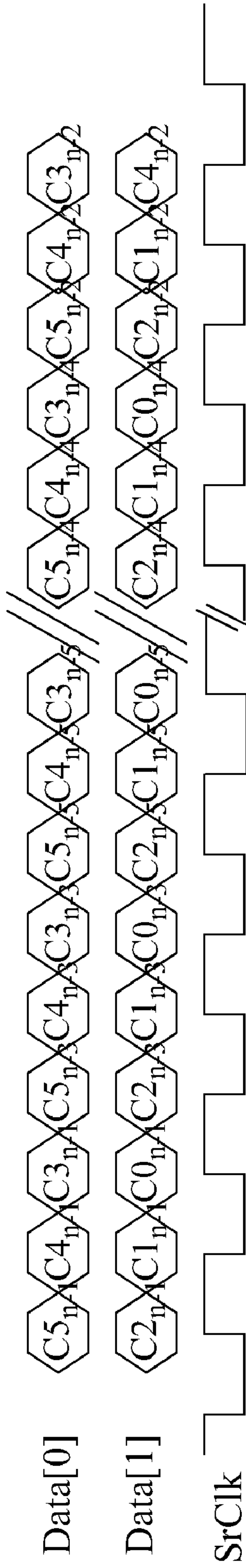

FIG. 60

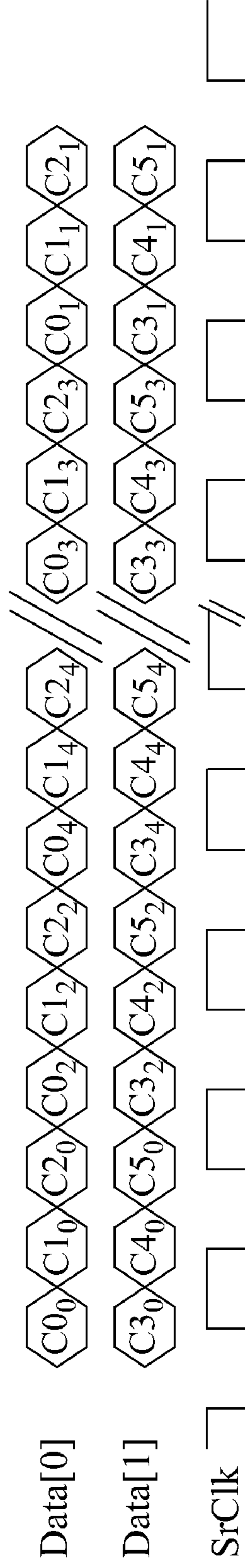

FIG. 61

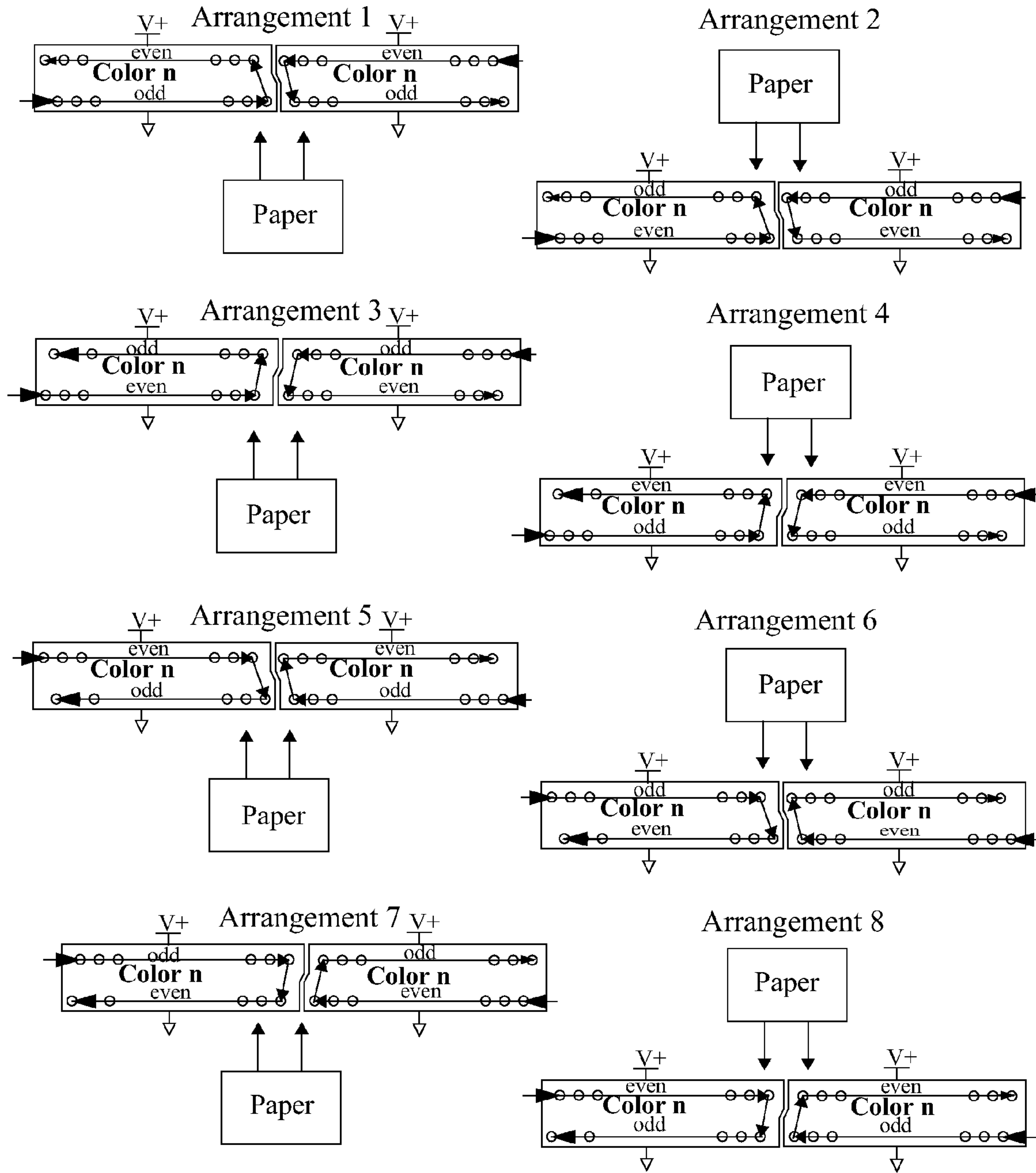

FIG. 62



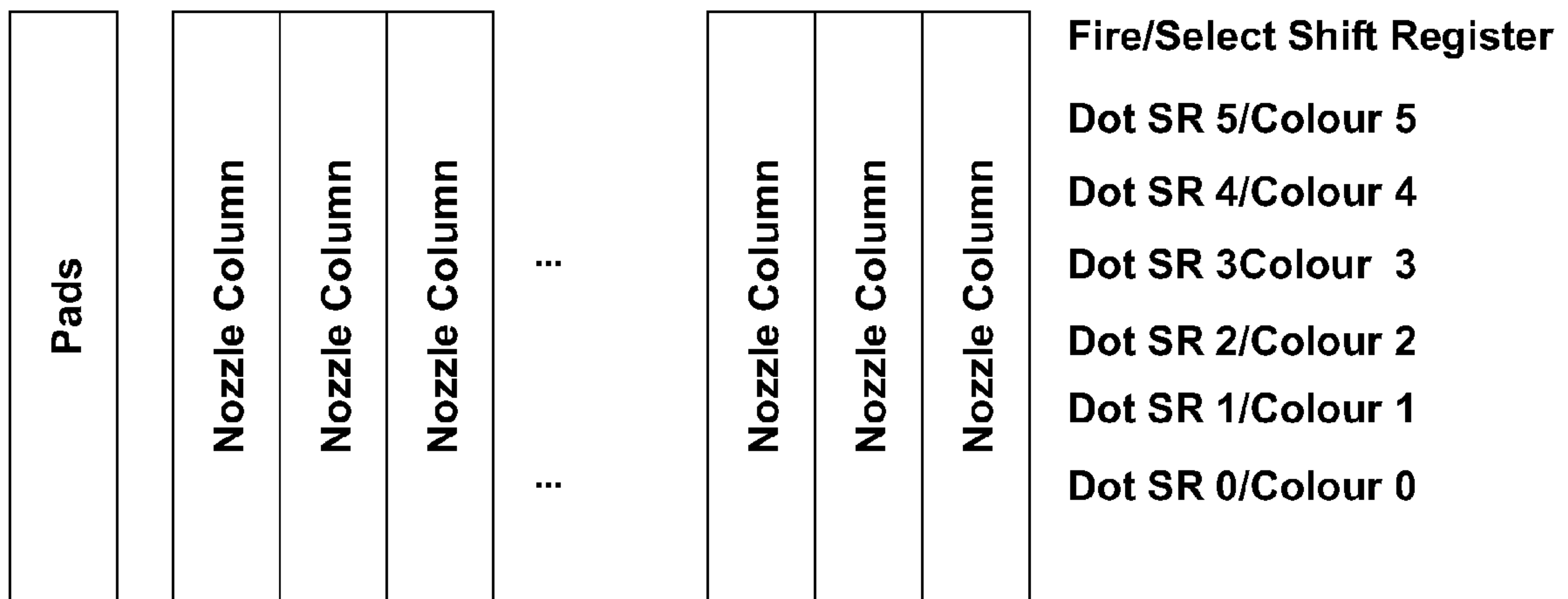

FIG. 63

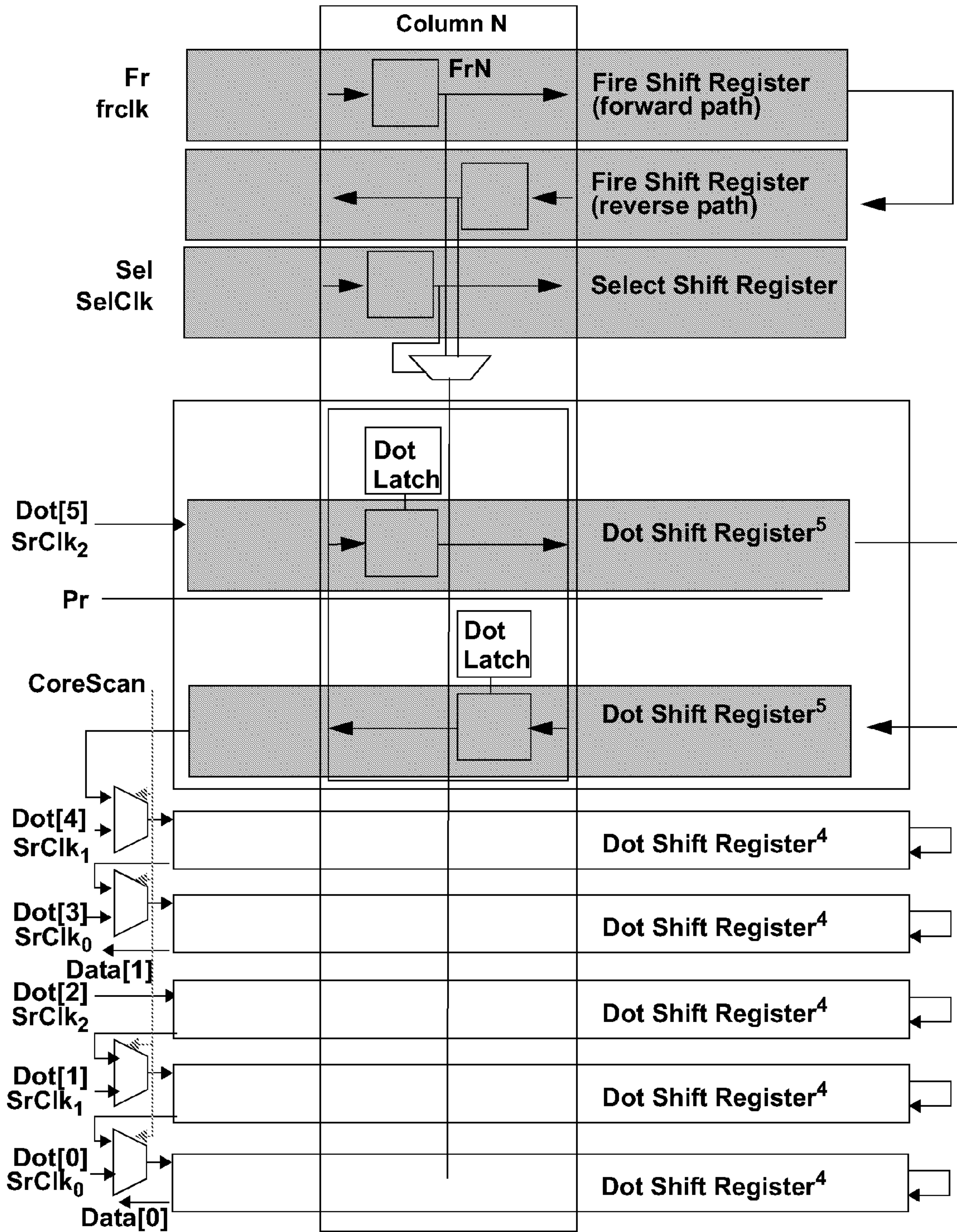

FIG. 64

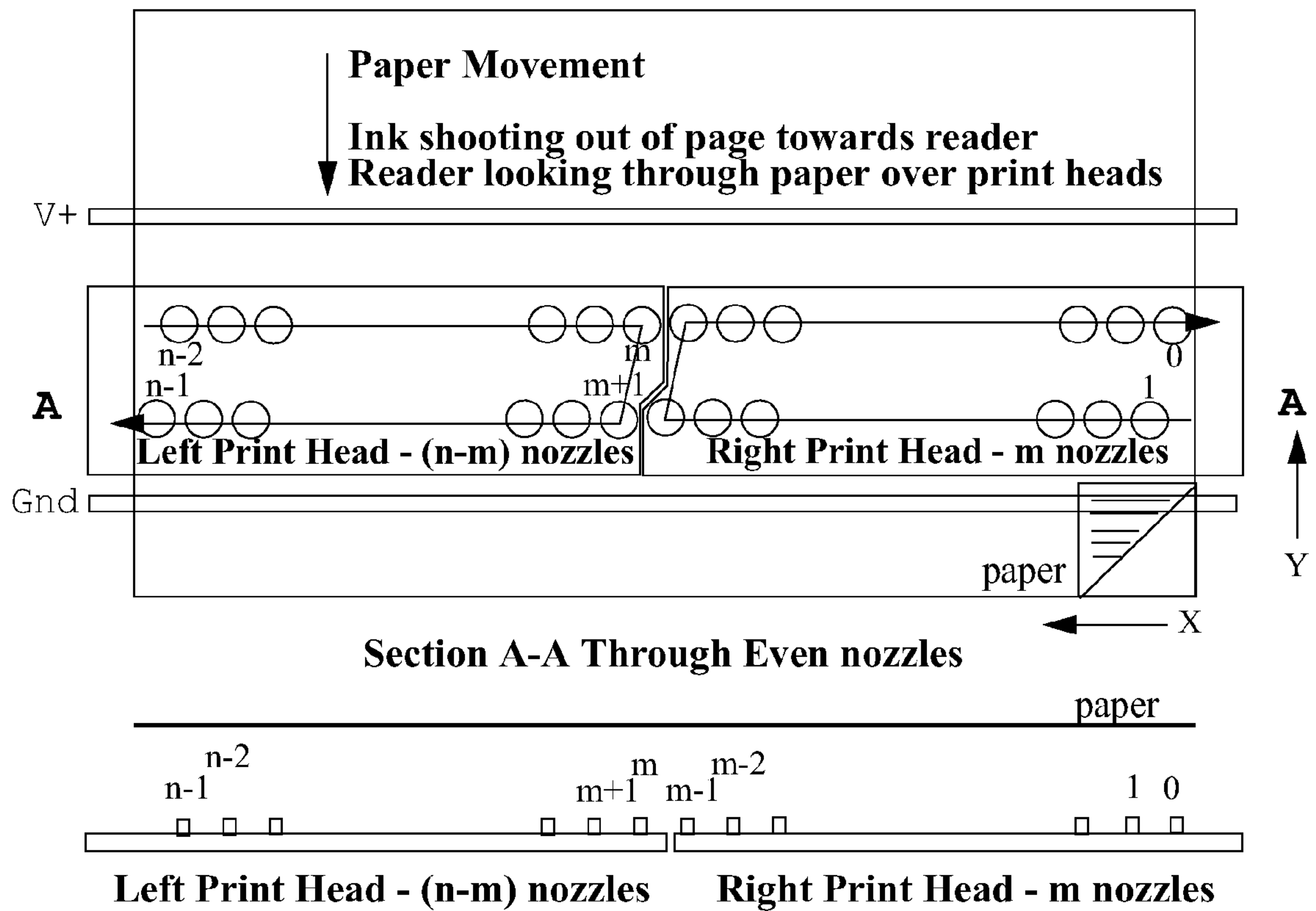

FIG. 65



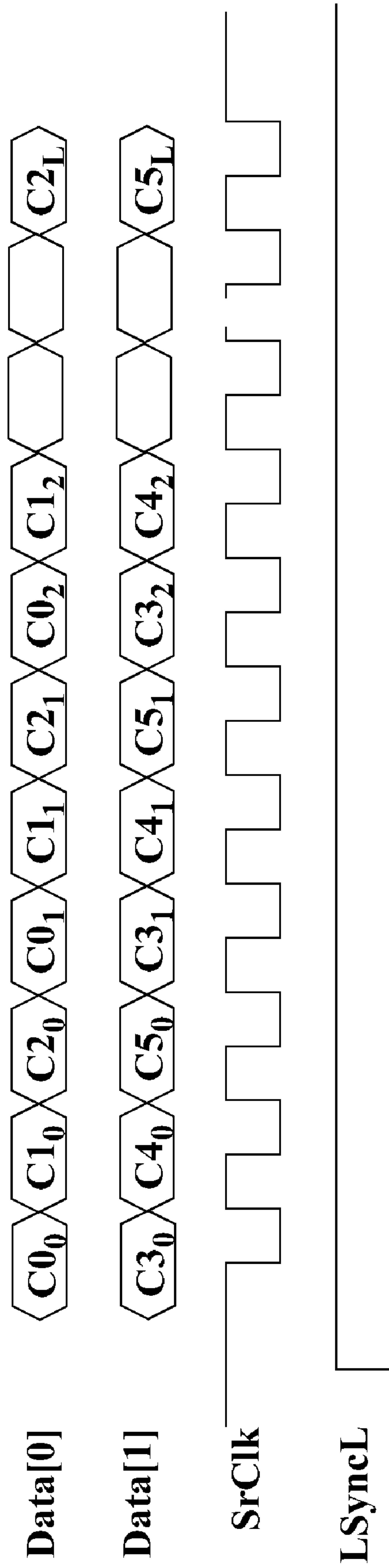
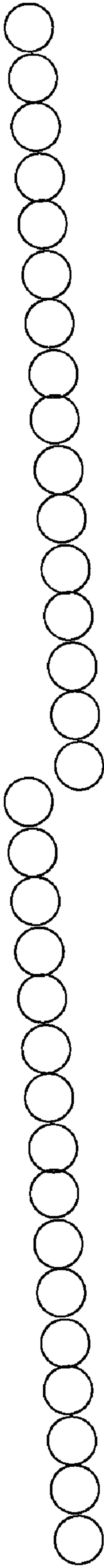
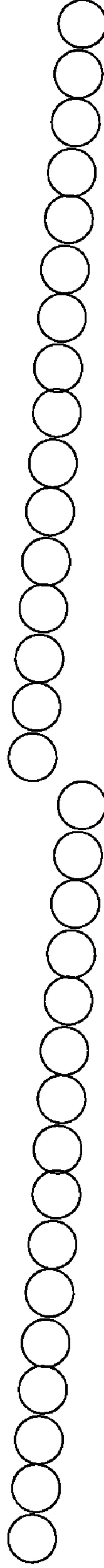

FIG. 66



**a) Printing every  $n^{\text{th}}$  dot with all zero's in the fire select shift register**



**b) Printing every  $n^{\text{th}}$  dot with all one's in the fire select shift register**

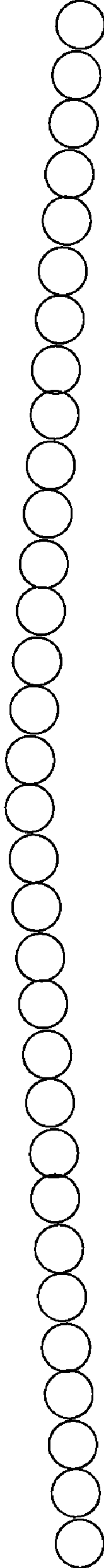

**c) Printing every  $n^{\text{th}}$  dot with n zero's then n one's in the fire select shift registers**

*FIG. 67*

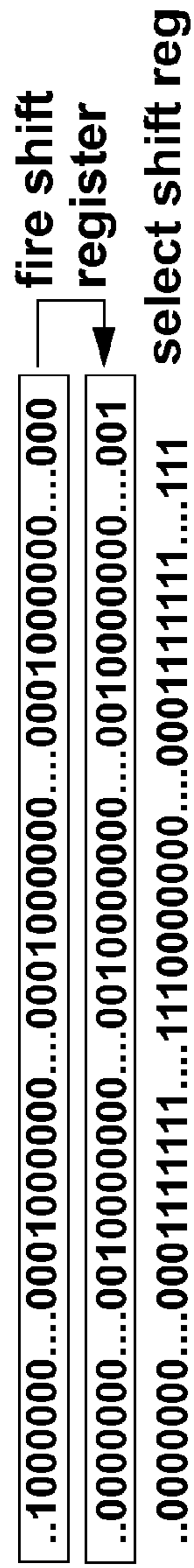

FIG. 68

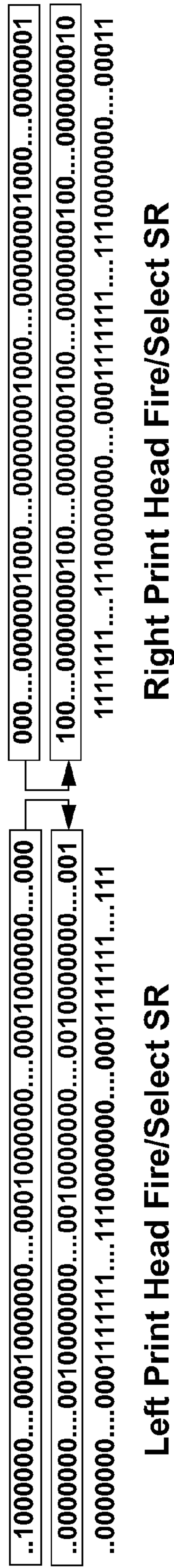

FIG. 69



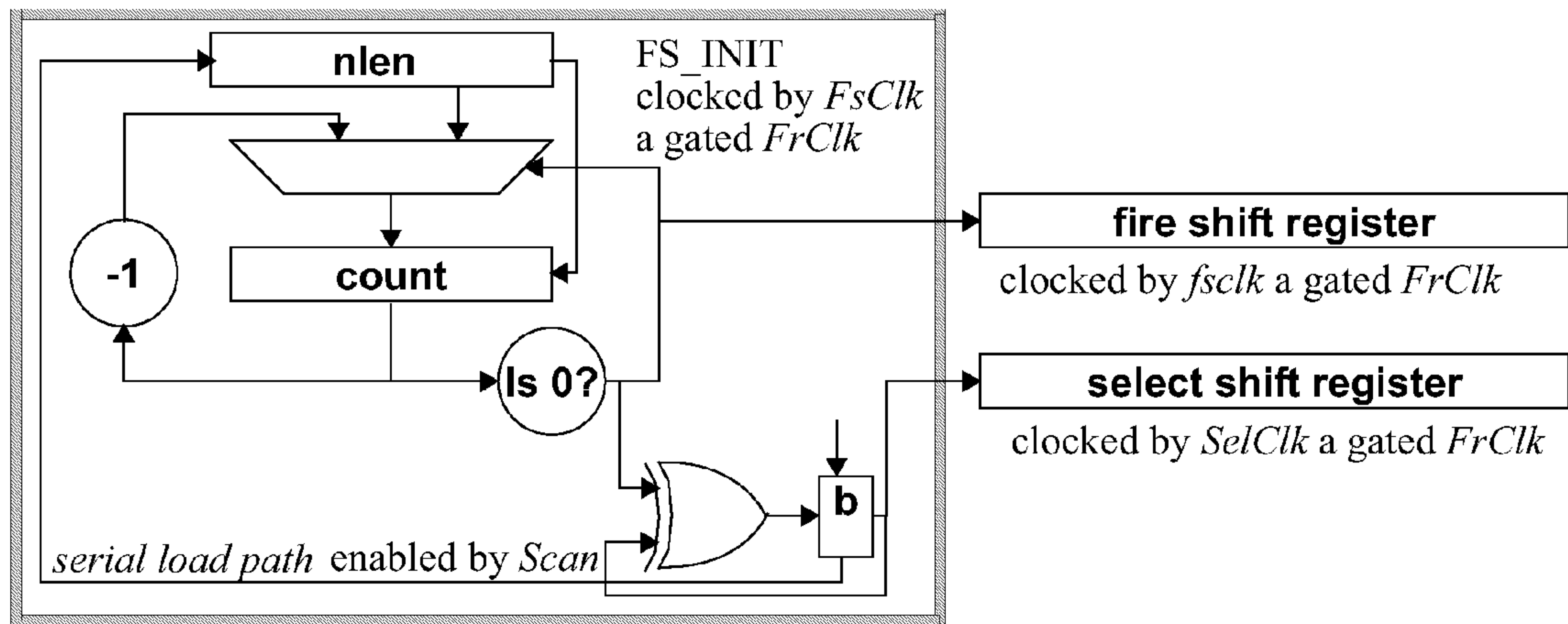

FIG. 70

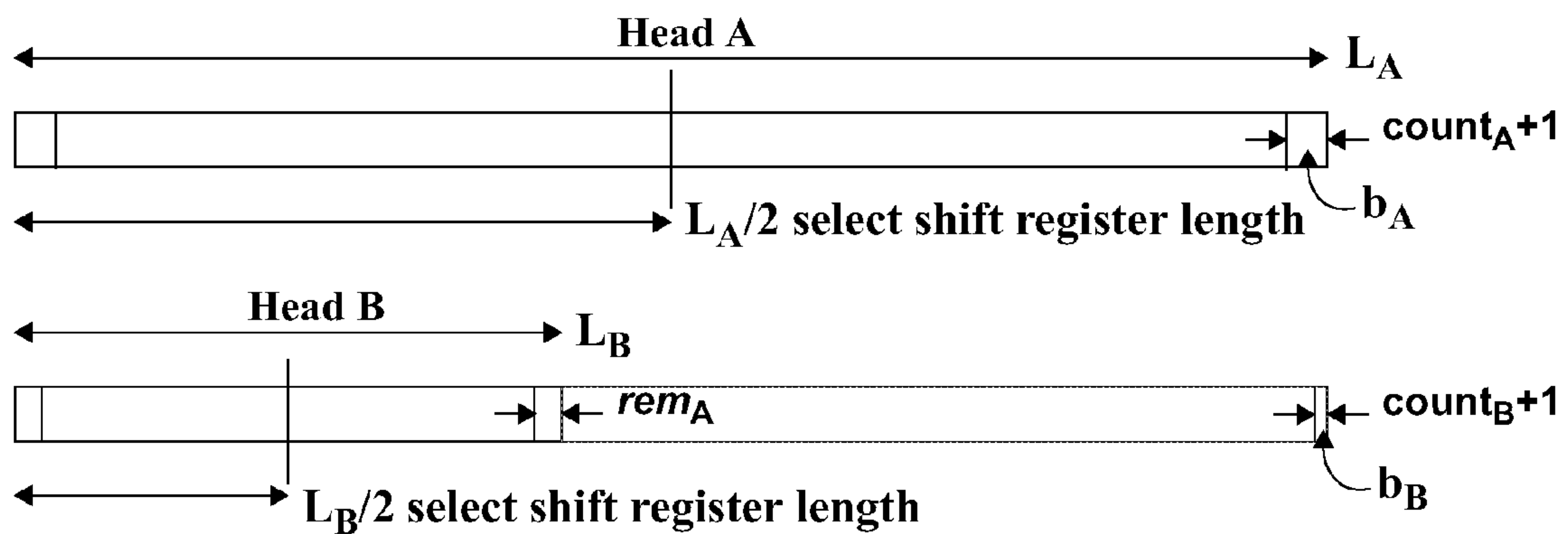

FIG. 71

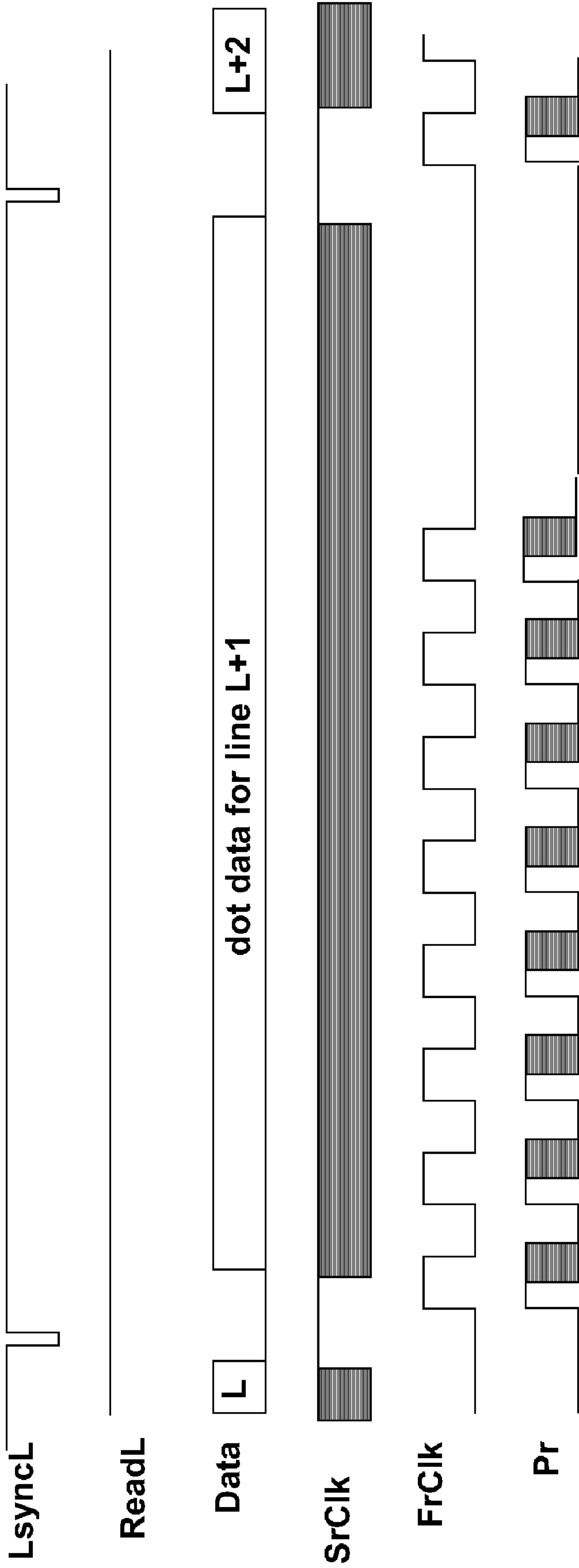

FIG. 72

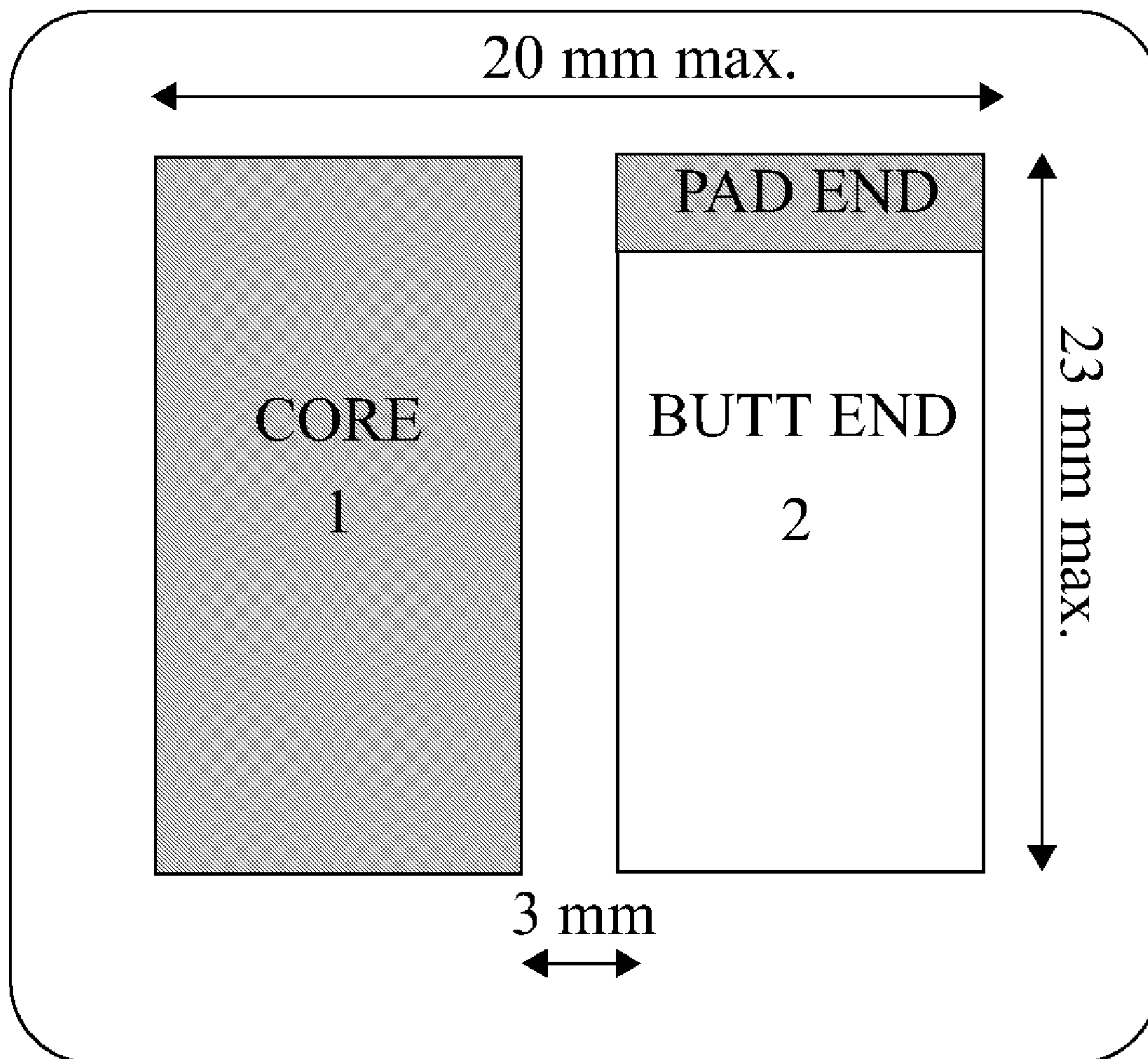

FIG. 73

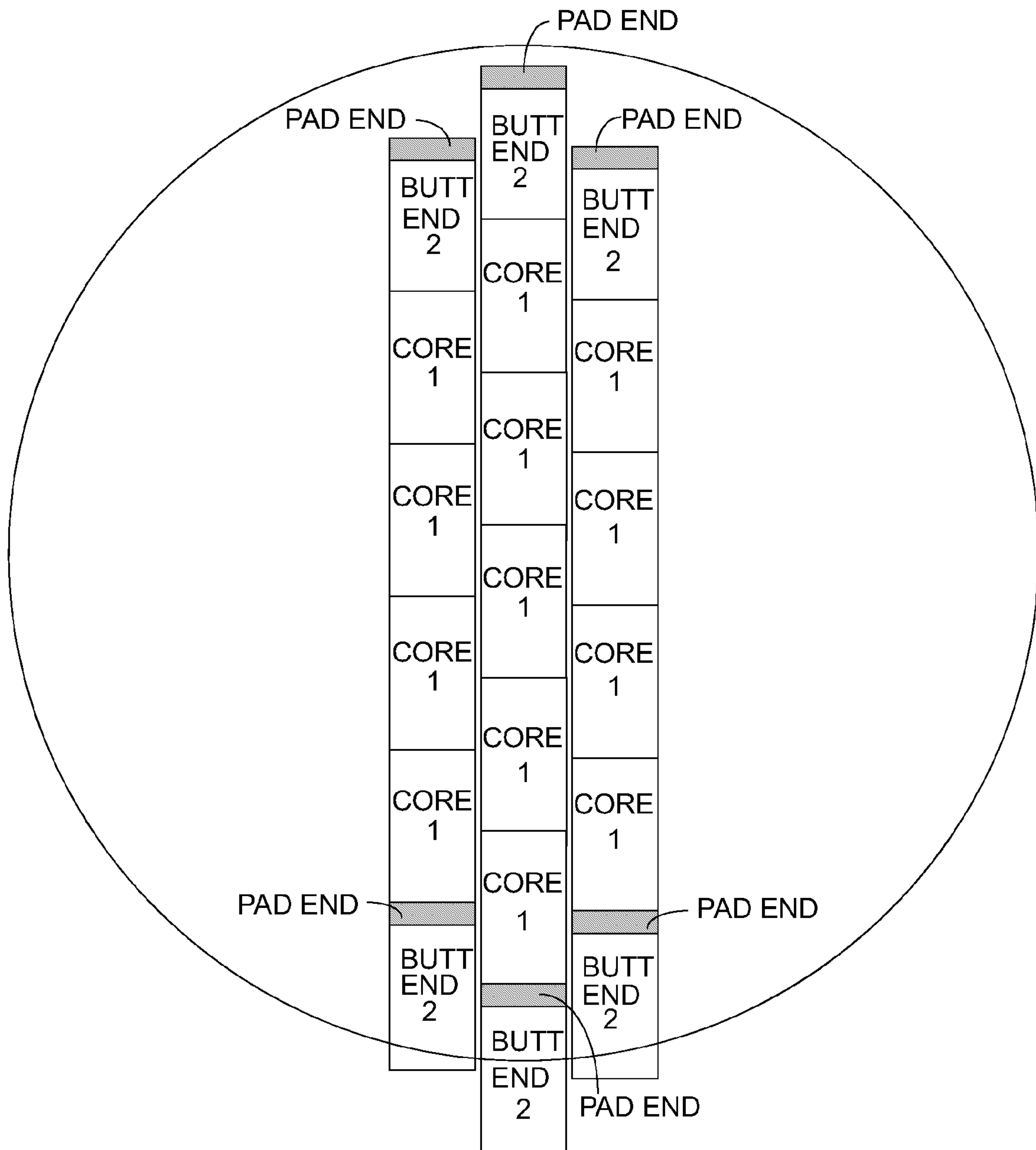

FIG. 74



## PRINTING SYSTEM HAVING CONTROLLED MULTI-LENGTH PRINthead ICS

### CROSS REFERENCE TO RELATED APPLICATIONS

The present application is a continuation of U.S. application Ser. No. 12/050,941 filed on Mar. 19, 2008, which is a continuation of U.S. application Ser. No. 10/727,245 filed Dec. 2, 2003, now issued U.S. Pat. No. 7,399,043 the entire contents of which are herein incorporated by reference.

### FIELD OF INVENTION

The present invention relates to techniques for providing data to a printhead such that the requirements of different length printhead modules comprising the printhead are taken into account.

The invention has primarily been developed for use with a printhead comprising one or more printhead modules constructed using microelectromechanical systems (MEMS) techniques, and will be described with reference to this application. However, it will be appreciated that the invention can be applied to other types of printing technologies in which analogous problems are faced.

### BACKGROUND OF INVENTION

Manufacturing a printhead that has relatively high resolution and print-speed raises a number of problems.

Difficulties in manufacturing pagewidth printheads of any substantial size arise due to the relatively small dimensions of standard silicon wafers that are used in printhead (or printhead module) manufacture. For example, if it is desired to make an 8 inch wide pagewidth printhead, only one such printhead can be laid out on a standard 8-inch wafer, since such wafers are circular in plan. Manufacturing a pagewidth printhead from two or more smaller modules can reduce this limitation to some extent, but raises other problems related to providing a joint between adjacent printhead modules that is precise enough to avoid visible artefacts (which would typically take the form of noticeable lines) when the printhead is used. The problem is exacerbated in relatively high-resolution applications because of the tight tolerances dictated by the small spacing between nozzles.

The quality of a joint region between adjacent printhead modules relies on factors including a precision with which the abutting ends of each module can be manufactured, the accuracy with which they can be aligned when assembled into a single printhead, and other more practical factors such as management of ink channels behind the nozzles. It will be appreciated that the difficulties include relative vertical displacement of the printhead modules with respect to each other.

Whilst some of these issues may be dealt with by careful design and manufacture, the level of precision required renders it relatively expensive to manufacture printheads within the required tolerances. It would be desirable to provide a solution to one or more of the problems associated with precision manufacture and assembly of multiple printhead modules to form a printhead, and especially a pagewidth printhead.

In some cases, it is desirable to produce a number of different printhead module types or lengths on a substrate to maximise usage of the substrate's surface area. However, different sizes and types of modules will have different numbers and layouts of print nozzles, potentially including dif-

ferent horizontal and vertical offsets. Where two or more modules are to be joined to form a single printhead, there is also the problem of dealing with different seam shapes between abutting ends of joined modules, which again may incorporate vertical or horizontal offsets between the modules. Printhead controllers are usually dedicated application specific integrated circuits (ASICs) designed for specific use with a single type of printhead module, that is used by itself rather than with other modules. It would be desirable to provide a way in which different lengths and types of printhead modules could be accounted for using a single printer controller.

Printer controllers face other difficulties when two or more printhead modules are involved, especially if it is desired to send dot data to each of the printheads directly (rather than via a single printhead connected to the controller). One concern is that data delivered to different length controllers at the same rate will cause the shorter of the modules to be ready for printing before any longer modules. Where there is little difference involved, the issue may not be of importance, but for large length differences, the result is that the bandwidth of a shared memory from which the dot data is supplied to the modules is effectively left idle once one of the modules is full and the remaining module or modules is still being filled. It would be desirable to provide a way of improving memory bandwidth usage in a system comprising a plurality of printhead modules of uneven length.

In any printing system that includes multiple nozzles on a printhead or printhead module, there is the possibility of one or more of the nozzles failing in the field, or being inoperative due to manufacturing defect. Given the relatively large size of a typical printhead module, it would be desirable to provide some form of compensation for one or more "dead" nozzles. Where the printhead also outputs fixative on a per-nozzle basis, it is also desirable that the fixative is provided in such a way that dead nozzles are compensated for.

A printer controller can take the form of an integrated circuit, comprising a processor and one or more peripheral hardware units for implementing specific data manipulation functions. A number of these units and the processor may need access to a common resource such as memory. One way of arbitrating between multiple access requests for a common resource is timeslot arbitration, in which access to the resource is guaranteed to a particular requester during a predetermined timeslot.

One difficulty with this arrangement lies in the fact that not all access requests make the same demands on the resource in terms of timing and latency. For example, a memory read requires that data be fetched from memory, which may take a number of cycles, whereas a memory write can commence immediately. Timeslot arbitration does not take into account these differences, which may result in accesses being performed in a less efficient manner than might otherwise be the case. It would be desirable to provide a timeslot arbitration scheme that improved this efficiency as compared with prior art timeslot arbitration schemes.

Also of concern when allocating resources in a timeslot arbitration scheme is the fact that the priority of an access request may not be the same for all units. For example, it would be desirable to provide a timeslot arbitration scheme in which one requestor (typically the memory) is granted special priority such that its requests are dealt with earlier than would be the case in the absence of such priority.

In systems that use a memory and cache, a cache miss (in which an attempt to load data or an instruction from a cache fails) results in a memory access followed by a cache update. It is often desirable when updating the cache in this way to



update data other than that which was actually missed. A typical example would be a cache miss for a byte resulting in an entire word or line of the cache associated with that byte being updated. However, this can have the effect of tying up bandwidth between the memory (or a memory manager) and the processor where the bandwidth is such that several cycles are required to transfer the entire word or line to the cache. It would be desirable to provide a mechanism for updating a cache that improved cache update speed and/or efficiency.

Most integrated circuits an externally provided signal as (or to generate) a clock, often provided from a dedicated clock generation circuit. This is often due to the difficulties of providing an onboard clock that can operate at a speed that is predictable. Manufacturing tolerances of such on-board clock generation circuitry can result in clock rates that vary by a factor of two, and operating temperatures can increase this margin by an additional factor of two. In some cases, the particular rate at which the clock operates is not of particular concern. However, where the integrated circuit will be writing to an internal circuit that is sensitive to the time over which a signal is provided, it may be undesirable to have the signal be applied for too long or short a time. For example, flash memory is sensitive to being written too for too long a period. It would be desirable to provide a mechanism for adjusting a rate of an on-chip system clock to take into account the impact of manufacturing variations on clockspeed.

A number of other aspects, features, preferences and embodiments are disclosed in the Detailed Description of the Preferred Embodiment below.

### SUMMARY OF THE INVENTION

In accordance with the invention, there is provided a printhead controller for supplying print data to a plurality of printhead integrated circuits of different lengths, the printhead integrated circuits being arranged to define a pagewidth printhead having rows of nozzles formed by adjacent nozzle rows of the adjacent printhead integrated circuits, the nozzle rows of the printhead being configured so that there is at least one row for printing each ink color of a plurality of ink colors, the printhead controller being configured to supply the print data to the printhead integrated circuits in accordance with their respective lengths, such that the difference in the lengths is at least partially compensated for in printing across the pagewidth.

Optionally, the printhead controller is configured to supply the print data to the nozzle rows in serial form.

Optionally, each of the printhead integrated circuits comprises one or more parallel pairs of the rows, the printhead controller being configured to serially supply the print data to a first of each of the rows in the or each pair of rows, the print data being serially clocked through the first row of the or each pair of rows, then through a second row of the or each pair or rows, until all nozzles have received their respective print data.

Optionally, the data is clocked through the second row in a direction substantially opposite to that in which it was clocked through the first row.

Optionally, the printer controller comprises a printhead interface in communication with a line loader unit.

Optionally, the printhead interface accepts two streams of print data from the line loader unit.

Optionally, the line loader unit includes two print data generator units.

Optionally, the line loader unit compensates for any vertical misalignment between the printhead integrated circuits.

Optionally, the print data is transferred to either the printhead integrated circuits from a memory under the control of the printhead controller.

Optionally, the printhead controller is configured to manipulate the supply of print data to each of the printhead integrated circuits such that usage of a memory bandwidth is substantially constant during a printhead loading cycle.

### BRIEF DESCRIPTION OF THE DRAWINGS

Preferred and other embodiments of the invention will now be described, by way of example only, with reference to the accompanying drawings, in which:

FIG. 1 shows document data flow in a printer

FIG. 2 is an example of a single printer controller (hereinafter "SoPEC") A4 simplex printer system

FIG. 3 is an example of a dual SoPEC A4 duplex printer system

FIG. 4 is an example of a dual SoPEC A3 simplex printer system

FIG. 5 is an example of a quad SoPEC A3 duplex printer system

FIG. 6 is an example of a SoPEC A4 simplex printing system with an extra SoPEC used as DRAM storage

FIG. 7 is an example of an A3 duplex printing system featuring four printing SoPECs

FIG. 8 shows pages containing different numbers of bands

FIG. 9 shows the contents of a page band

FIG. 10 illustrates a page data path from host to SoPEC

FIG. 11 shows a page structure

FIG. 12 shows a SoPEC system top level partition

FIG. 13 shows a SoPEC CPU memory map (not to scale)

FIG. 14 is a block diagram of CPU

FIG. 15 shows CPU bus transactions

FIG. 16 shows a state machine for a CPU subsystem slave

FIG. 17 shows a SoPEC CPU memory map (not to scale)

FIG. 18 shows a high-level data flow diagram of DWU in context

FIG. 19 shows a printhead nozzle layout for 36-nozzle bi-lithic printhead

FIG. 20 shows a printhead nozzle layout for a 36-nozzle bi-lithic printhead

FIG. 21 shows a dot line store logical representation

FIG. 22 shows a conceptual view of printhead row alignment

FIG. 23 shows a conceptual view of printhead rows (as seen by the LLU and PHI)

FIG. 24 shows a comparison of 1.5xv 2x buffering

FIG. 25 shows an even dot order in DRAM (increasing sense, 13320 dot wide line)

FIG. 26 shows an even dot order in DRAM (decreasing sense, 13320 dot wide line)

FIG. 27 shows a dotline FIFO data structure in DRAM

FIG. 28 shows a DWU partition

FIG. 29 shows a buffer address generator sub-block

FIG. 30 shows a DIU Interface sub-block

FIG. 31 shows an interface controller state diagram

FIG. 32 shows a high level data flow diagram of LLU in context

FIG. 33 shows paper and printhead nozzles relationship (example with  $D_1=D_2=5$ )

FIG. 34 shows printhead structure and dot generate order

FIG. 35 shows an order of dot data generation and transmission

FIG. 36 shows a conceptual view of printhead rows

FIG. 37 shows a dotline FIFO data structure in DRAM (LLU specification)



## 5

FIG. 38 shows an LLU partition  
 FIG. 39 shows a dot generator RTL diagram  
 FIG. 40 shows a DIU interface  
 FIG. 41 shows an interface controller state diagram  
 FIG. 42 shows high-level data flow diagram of PHI in context  
 FIG. 43 shows power on reset  
 FIG. 44 shows printhead data rate equalization  
 FIG. 45 shows a printhead structure and dot generate order  
 FIG. 46 shows an order of dot data generation and transmission  
 FIG. 47 shows an order of dot data generation and transmission (single printhead case)  
 FIG. 48 shows printhead interface timing parameters  
 FIG. 49 shows printhead timing with margining  
 FIG. 50 shows printhead types 0 to 7  
 FIG. 51 shows an ideal join between two dilithic printhead segments  
 FIG. 52 shows an example of a join between two bilithic printhead segments  
 FIG. 53 shows printable vs non-printable area under new definition (looking at colors as if 1 row only)  
 FIG. 54 shows identification of printhead nozzles and shift-register sequences for printheads in arrangement 1  
 FIG. 55 shows demultiplexing of data within the printheads in arrangement 1  
 FIG. 56 shows double data rate signalling for a type 0 printhead in arrangement 1  
 FIG. 57 shows double data rate signalling for a type 1 printhead in arrangement 1  
 FIG. 58 shows identification of printheads nozzles and shift-register sequences for printheads in arrangement 2  
 FIG. 59 shows demultiplexing of data within the printheads in arrangement 2  
 FIG. 60 shows double data rate signalling for a type 0 printhead in arrangement 2  
 FIG. 61 shows double data rate signalling for a type 1 printhead in arrangement 2  
 FIG. 62 shows all 8 printhead arrangements  
 FIG. 63 shows a printhead structure  
 FIG. 64 shows a column Structure  
 FIG. 65 shows a printhead dot shift register dot mapping to page  
 FIG. 66 shows data timing during printing  
 FIG. 67 shows print quality  
 FIG. 68 shows fire and select shift register setup for printing  
 FIG. 69 shows a fire pattern across butt end of printhead chips  
 FIG. 70 shows fire pattern generation  
 FIG. 71 shows determination of select shift register value  
 FIG. 72 shows timing for printing signals  
 FIG. 73 shows a reticle layout  
 FIG. 74 shows a stepper pattern on Wafer

DETAILED DESCRIPTION OF THE  
 EMBODIMENTS

Imperative phrases such as “must”, “requires”, “necessary” and “important” (and similar language) should be read as being indicative of being necessary only for the preferred embodiment actually being described. As such, unless the opposite is clear from the context, imperative wording should not be interpreted as such. Nothing in the detailed description is to be understood as limiting the scope of the invention, which is intended to be defined as widely as is defined in the accompanying claims.

## 6

The present invention provides a printer using microelectromechanical systems (MEMS) printheads. The printer can receive data from, for example, a personal computer such as an IBM compatible PC or Apple computer. In other embodiments, the printer can receive data directly from, for example, a digital still or video camera. The particular choice of communication link is not important, and can be based, for example, on USB, Firewire, Bluetooth or any other wireless or hardwired communications protocol.

The SoPEC (Small office home office Print Engine Controller) ASIC (Application Specific Integrated Circuit) suitable for use in, for example, SoHo printer products is described. The SoPEC ASIC is intended to be a low cost solution for bi-lithic printhead control, replacing the multi-chip solutions in larger more professional systems with a single chip. The increased cost competitiveness is achieved by integrating several systems such as a modified PEC1 printing pipeline, CPU control system, peripherals and memory sub-system onto one SoC ASIC, reducing component count and simplifying board design.

A bi-lithic based printhead is constructed from 2 printhead ICs of varying sizes. The notation M:N is used to express the size relationship of each IC, where M specifies one printhead IC in inches and N specifies the remaining printhead IC in inches.

The following terms are used throughout this specification: Bi-lithic printhead Refers to printhead constructed from 2 printhead ICs

CPU Refers to CPU core, caching system and MMU.

ISI-Bridge chip A device with a high speed interface (such as USB2.0, Ethernet or IEEE1394) and one or more ISI interfaces. The ISI-Bridge would be the ISIMaster for each of the ISI buses it interfaces to.

ISIMaster The ISIMaster is the only device allowed to initiate communication on the Inter Sopec Interface (ISI) bus. The ISIMaster interfaces with the host.

ISISlave Multi-SoPEC systems will contain one or more ISISlave SoPECs connected to the ISI bus. ISISlaves can only respond to communication initiated by the ISIMaster.

LEON Refers to the LEON CPU core.

LineSyncMaster The LineSyncMaster device generates the line synchronisation pulse that all SoPECs in the system must synchronise their line outputs to.

Multi-SoPEC Refers to SoPEC based print system with multiple SoPEC devices

Netpage Refers to page printed with tags (normally in infrared ink).

PEC1 Refers to Print Engine Controller version 1, precursor to SoPEC used to control printheads constructed from multiple angled printhead segments.

Printhead IC Single MEMS IC used to construct bi-lithic printhead

PrintMaster The PrintMaster device is responsible for coordinating all aspects of the print operation. There may only be one PrintMaster in a system.

QA Chip Quality Assurance Chip

Storage SoPEC An ISISlave SoPEC used as a DRAM store and which does not print.

Tag Refers to pattern which encodes information about its position and orientation which allow it to be optically located and its data contents read.

The following acronyms and abbreviations are used in this specification

CFU Contone FIFO Unit

CPU Central Processing Unit



DIU DRAM Interface Unit  
 DNC Dead Nozzle Compensator  
 DRAM Dynamic Random Access Memory  
 DWU DotLine Writer Unit  
 GPIO General Purpose Input Output  
 HCU Halftoner Compositor Unit  
 ICU Interrupt Controller Unit  
 ISI Inter SoPEC Interface  
 LDB Lossless Bi-level Decoder  
 LLU Line Loader Unit  
 LSS Low Speed Serial interface  
 MEMS Micro Electro Mechanical System  
 MMU Memory Management Unit  
 PCU SoPEC Controller Unit  
 PHI PrintHead Interface  
 PSS Power Save Storage Unit  
 RDU Real-time Debug Unit  
 ROM Read Only Memory  
 SCB Serial Communication Block  
 SFU Spot FIFO Unit  
 SMG4 Silverbrook Modified Group 4.  
 SoPEC Small office home office Print Engine Controller  
 SRAM Static Random Access Memory  
 TE Tag Encoder  
 TFU Tag FIFO Unit  
 TIM Timers Unit  
 USB Universal Serial Bus

A bi-lithic printhead produces 1600 dpi bi-level dots. On low-diffusion paper, each ejected drop forms a 22.5 m diameter dot. Dots are easily produced in isolation, allowing dispersed-dot dithering to be exploited to its fullest. Since the bi-lithic printhead is the width of the page and operates with a constant paper velocity, color planes are printed in perfect registration, allowing ideal dot-on-dot printing. Dot-on-dot printing minimizes ‘muddying’ of midtones caused by inter-color bleed.

A page layout may contain a mixture of images, graphics and text. Continuous-tone (contone) images and graphics are reproduced using a stochastic dispersed-dot dither. Unlike a clustered-dot (or amplitude-modulated) dither, a dispersed-dot (or frequency-modulated) dither reproduces high spatial frequencies (i.e. image detail) almost to the limits of the dot resolution, while simultaneously reproducing lower spatial frequencies to their full color depth, when spatially integrated by the eye. A stochastic dither matrix is carefully designed to be free of objectionable low-frequency patterns when tiled across the image. As such its size typically exceeds the minimum size required to support a particular number of intensity levels (e.g. 16×16×8 bits for 257 intensity levels).

Human contrast sensitivity peaks at a spatial frequency of about 3 cycles per degree of visual field and then falls off logarithmically, decreasing by a factor of 100 beyond about 40 cycles per degree and becoming immeasurable beyond 60 cycles per degree [25][25]. At a normal viewing distance of

12 inches (about 300 mm), this translates roughly to 200-300 cycles per inch (cpi) on the printed page, or 400-600 samples per inch according to Nyquist’s theorem.

In practice, contone resolution above about 300 ppi is of limited utility outside special applications such as medical imaging. Offset printing of magazines, for example, uses contone resolutions in the range 150 to 300 ppi. Higher resolutions contribute slightly to color error through the dither.

Black text and graphics are reproduced directly using bi-level black dots, and are therefore not anti-aliased (i.e. low-pass filtered) before being printed. Text should therefore be supersampled beyond the perceptual limits discussed above, to produce smoother edges when spatially integrated by the eye. Text resolution up to about 1200 dpi continues to contribute to perceived text sharpness (assuming low-diffusion paper, of course).

A Netpage printer, for example, may use a contone resolution of 267 ppi (i.e. 1600 dpi/6), and a black text and graphics resolution of 800 dpi. A high end office or departmental printer may use a contone resolution of 320 ppi (1600 dpi/5) and a black text and graphics resolution of 1600 dpi. Both formats are capable of exceeding the quality of commercial (offset) printing and photographic reproduction.

Because of the page-width nature of the bi-lithic printhead, each page must be printed at a constant speed to avoid creating visible artifacts. This means that the printing speed can’t be varied to match the input data rate. Document rasterization and document printing are therefore decoupled to ensure the printhead has a constant supply of data. A page is never printed until it is fully rasterized. This can be achieved by storing a compressed version of each rasterized page image in memory.

This decoupling also allows the RIP(s) to run ahead of the printer when rasterizing simple pages, buying time to rasterize more complex pages.

Because contone color images are reproduced by stochastic dithering, but black text and line graphics are reproduced directly using dots, the compressed page image format contains a separate foreground bi-level black layer and background contone color layer. The black layer is composited over the contone layer after the contone layer is dithered (although the contone layer has an optional black component). A final layer of Netpage tags (in infrared or black ink) is optionally added to the page for printout.

FIG. 1 shows the flow of a document from computer system to printed page.

At 267 ppi for example, a A4 page (8.26 inches×11.7 inches) of contone CMYK data has a size of 26.3 MB. At 320 ppi, an A4 page of contone data has a size of 37.8 MB. Using lossy contone compression algorithms such as JPEG, contone images compress with a ratio up to 10:1 without noticeable loss of quality, giving compressed page sizes of 2.63 MB at 267 ppi and 3.78 MB at 320 ppi.

At 800 dpi, a A4 page of bi-level data has a size of 7.4 MB. At 1600 dpi, a Letter page of bi-level data has a size of 29.5 MB. Coherent data such as text compresses very well. Using lossless bi-level compression algorithms such as SMG4 fax, ten-point plain text compresses with a ratio of about 50:1. Lossless bi-level compression across an average page is about 20:1 with 10:1 possible for pages which compress poorly. The requirement for SoPEC is to be able to print text at 10:1 compression. Assuming 10:1 compression gives compressed page sizes of 0.74 MB at 800 dpi, and 2.95 MB at 1600 dpi.

Once dithered, a page of CMYK contone image data consists of 116 MB of bi-level data.



Using lossless bi-level compression algorithms on this data is pointless precisely because the optimal dither is stochastic—i.e. since it introduces hard-to-compress disorder.

Netpage tag data is optionally supplied with the page image. Rather than storing a compressed bi-level data layer for the Netpage tags, the tag data is stored in its raw form. Each tag is supplied up to 120 bits of raw variable data (combined with up to 56 bits of raw fixed data) and covers up to a 6 mm×6 mm area (at 1600 dpi). The absolute maximum number of tags on a A4 page is 15,540 when the tag is only 2 mm×2 mm (each tag is 126 dots×126 dots, for a total coverage of 148 tags×105 tags). 15,540 tags of 128 bits per tag gives a compressed tag page size of 0.24 MB.

The multi-layer compressed page image format therefore exploits the relative strengths of lossy JPEG contone image compression, lossless bi-level text compression, and tag encoding. The format is compact enough to be storage-efficient, and simple enough to allow straightforward real-time expansion during printing.

Since text and images normally don't overlap, the normal worst-case page image size is image only, while the normal best-case page image size is text only. The addition of worst case Netpage tags adds 0.24 MB to the page image size. The worst-case page image size is text over image plus tags. The average page size assumes a quarter of an average page contains images.

The SoPEC device can be used in several printer configurations and architectures.

In the general sense every SoPEC based printer architecture will contain:

- One or more SoPEC devices.
- One or more bi-lithic printheads.
- Two or more LSS busses.
- Two or more QA chips.
- USB 1.1 connection to host or ISI connection to Bridge Chip.
- ISI bus connection between SoPECs (when multiple SoPECs are used).

The SoPEC device contains several system on a chip (SoC) components, as well as the print engine pipeline control application specific logic.

The PEP reads compressed page store data from the embedded memory, optionally decompresses the data and formats it for sending to the printhead. The print engine pipeline functionality includes expanding the page image, dithering the contone layer, compositing the black layer over the contone layer, rendering of Netpage tags, compensation for dead nozzles in the printhead, and sending the resultant image to the bi-lithic printhead. SoPEC contains an embedded CPU for general purpose system configuration and management. The CPU performs page and band header processing, motor control and sensor monitoring (via the GPIO) and other system control functions. The CPU can perform buffer management or report buffer status to the host. The CPU can optionally run vendor application specific code for general print control such as paper ready monitoring and LED status update.

A 2.5 Mbyte embedded memory buffer is integrated onto the SoPEC device, of which approximately 2 Mbytes are available for compressed page store data. A compressed page is divided into one or more bands, with a number of bands stored in memory. As a band of the page is consumed by the PEP for printing a new band can be downloaded. The new band may be for the current page or the next page.

Using banding it is possible to begin printing a page before the complete compressed page is downloaded, but care must be taken to ensure that data is always available for printing or a buffer underrun may occur.

The embedded USB 1.1 device accepts compressed page data and control commands from the host PC, and facilitates the data transfer to either embedded memory or to another SoPEC device in multi-SoPEC systems.

The printhead is constructed by abutting 2 printhead ICs together. The printhead ICs can vary in size from 2 inches to 8 inches, so to produce an A4 printhead several combinations are possible. For example two printhead ICs of 7 inches and 3 inches could be used to create a A4 printhead (the notation is 7:3). Similarly 6 and 4 combination (6:4), or 5:5 combination. For an A3 printhead it can be constructed from 8:6 or an 7:7 printhead IC combination. For photographic printing smaller printheads can be constructed.

Each SoPEC device has 2 LSS system buses for communication with QA devices for system authentication and ink usage accounting. The number of QA devices per bus and their position in the system is unrestricted with the exception that PRINTER\_QA and INK\_QA devices should be on separate LSS busses.

Each SoPEC system can have several QA devices. Normally each printing SoPEC will have an associated PRINTER\_QA. Ink cartridges will contain an INK\_QA chip. PRINTER\_QA and INK\_QA devices should be on separate LSS busses. All QA chips in the system are physically identical with flash memory contents defining PRINTER\_QA from INK\_QA chip.

The Inter-SoPEC Interface (ISI) provides a communication channel between SoPECs in a multi-SoPEC system. The ISIMaster can be SoPEC device or an ISI-Bridge chip depending on the printer configuration. Both compressed data and control commands are transferred via the interface.

A device, other than a SoPEC with a USB connection, which provides print data to a number of slave SoPECs. A bridge chip will typically have a high bandwidth connection, such as USB2.0, Ethernet or IEEE1394, to a host and may have an attached external DRAM for compressed page storage. A bridge chip would have one or more ISI interfaces. The use of multiple ISI buses would allow the construction of independent print systems within the one printer. The ISI-Bridge would be the ISIMaster for each of the ISI buses it interfaces to.

Several possible SoPEC based system architectures exist. The following outline some possible architectures. It is possible to have extra SoPEC devices in the system used for DRAM storage. The QA chip configurations shown are indicative of the flexibility of LSS bus architecture, but not limited to those configurations.

In FIG. 2, a single SoPEC device can be used to control two printhead ICs. The SoPEC receives compressed data through the USB device from the host. The compressed data is processed and transferred to the printhead.

In FIG. 3, two SoPEC devices are used to control two bi-lithic printheads, each with two printhead ICs. Each bi-lithic printhead prints to opposite sides of the same page to achieve duplex printing. The SoPEC connected to the USB is the ISIMaster SoPEC, the remaining SoPEC is an ISISlave. The ISIMaster receives all the compressed page data for both SoPECs and re-distributes the compressed data over the Inter-SoPEC Interface (ISI) bus. It may not be possible to print an A4 page every 2 seconds in this configuration since the USB 1.1 connection to the host may not have enough bandwidth. An alternative would be for each SoPEC to have its own USB 1.1 connection. This would allow a faster average print speed.



## 11

In FIG. 4, two SoPEC devices are used to control one A3 bi-lithic printhead. Each SoPEC controls only one printhead IC (the remaining PHI port typically remains idle). This system uses the SoPEC with the USB connection as the ISIMaster. In this dual SoPEC configuration the compressed page store data is split across 2 SoPECs giving a total of 4 Mbyte page store, this allows the system to use compression rates as in an A4 architecture, but with the increased page size of A3. The ISIMaster receives all the compressed page data for all SoPECs and re-distributes the compressed data over the Inter-SoPEC Interface (ISI) bus.

It may not be possible to print an A3 page every 2 seconds in this configuration since the USB 1.1 connection to the host will only have enough bandwidth to supply 2 Mbytes every 2 seconds. Pages which require more than 2 MBytes every 2 seconds will therefore print more slowly. An alternative would be for each SoPEC to have its own USB 1.1 connection. This would allow a faster average print speed.

In FIG. 5 a 4 SoPEC system is shown. It contains 2 A3 bi-lithic printheads, one for each side of an A3 page. Each printhead contain 2 printhead ICs, each printhead IC is controlled by an independent SoPEC device, with the remaining PHI port typically unused. Again the SoPEC with USB 1.1 connection is the ISIMaster with the other SoPECs as ISISlaves. In total, the system contains 8 Mbytes of compressed page store (2 Mbytes per SoPEC), so the increased page size does not degrade the system print quality, from that of an A4 simplex printer. The ISIMaster receives all the compressed page data for all SoPECs and re-distributes the compressed data over the Inter-SoPEC Interface (ISI) bus.

It may not be possible to print an A3 page every 2 seconds in this configuration since the USB 1.1 connection to the host will only have enough bandwidth to supply 2 Mbytes every 2 seconds. Pages which require more than 2 MBytes every 2 seconds will therefore print more slowly. An alternative would be for each SoPEC or set of SoPECs on the same side of the page to have their own USB 1.1 connection (as ISISlaves may also have direct USB connections to the host). This would allow a faster average print speed.

Extra SoPECs can be used for DRAM storage e.g. in FIG. 6 an A4 simplex printer can be built with a single extra SoPEC used for DRAM storage. The DRAM SoPEC can provide guaranteed bandwidth delivery of data to the printing SoPEC. SoPEC configurations can have multiple extra SoPECs used for DRAM storage.

In FIG. 7, an ISI-Bridge chip provides slave-only ISI connections to SoPEC devices. FIG. 7 shows a ISI-Bridge chip with 2 separate ISI ports. The ISI-Bridge chip is the ISIMaster on each of the ISI busses it is connected to. All connected SoPECs are ISISlaves. The ISI-Bridge chip will typically have a high bandwidth connection to a host and may have an attached external DRAM for compressed page storage.

## 12

An alternative to having a ISI-Bridge chip would be for each SoPEC or each set of SoPECs on the same side of a page to have their own USB 1.1 connection. This would allow a faster average print speed.

The SoPEC is a page rendering engine ASIC that takes compressed page images as input, and produces decompressed page images at up to 6 channels of bi-level dot data as output. The bi-level dot data is generated for the Memjet bi-lithic printhead. The dot generation process takes account of printhead construction, dead nozzles, and allows for fixative generation.

A single SoPEC can control 2 bi-lithic printheads and up to 6 color channels at 10,000 lines/sec<sup>1</sup>, equating to 30 pages per minute. A single SoPEC can perform full-bleed printing of A3, A4 and Letter pages. The 6 channels of colored ink are the expected maximum in a consumer SOHO, or office Bi-lithic printing environment:

<sup>1</sup>10,000 lines per second equates to 30 A4/Letter pages per minute at 1600 dpi CMY, for regular color printing.

K, for black text, line graphics and gray-scale printing.

IR (infrared), for Netpage-enabled [5] applications.

F (fixative), to enable printing at high speed. Because the bi-lithic printer is capable of printing so fast, a fixative may be required to enable the ink to dry before the page touches the page already printed. Otherwise the pages may bleed on each other. In low speed printing environments the fixative may not be required.

SoPEC is color space agnostic. Although it can accept contone data as CMYX or RGBX, where X is an optional 4th channel, it also can accept contone data in any print color space. Additionally, SoPEC provides a mechanism for arbitrary mapping of input channels to output channels, including combining dots for ink optimization, generation of channels based on any number of other channels etc. However, inputs are typically CMYK for contone input, K for the bi-level input, and the optional Netpage tag dots are typically rendered to an infra-red layer. A fixative channel is typically generated for fast printing applications.

SoPEC is resolution agnostic. It merely provides a mapping between input resolutions and output resolutions by means of scale factors. The expected output resolution is 1600 dpi, but SoPEC actually has no knowledge of the physical resolution of the Bi-lithic printhead. SoPEC is page-length agnostic. Successive pages are typically split into bands and downloaded into the page store as each band of information is consumed and becomes free. SoPEC provides an interface for synchronization with other SoPECs. This allows simple multi-SoPEC solutions for simultaneous A3/A4/Letter duplex printing. However, SoPEC is also capable of printing only a portion of a page image. Combining synchronization functionality with partial page rendering allows multiple SoPECs to be readily combined for alternative printing requirements including simultaneous duplex printing and wide format printing. Table 1 lists some of the features and corresponding benefits of SoPEC.

TABLE 1

Features and Benefits of SoPEC	
Feature	Benefits
Optimised print architecture in hardware	30 ppm full page photographic quality color printing from a desktop PC
0.13 micron CMOS	High speed
(>3 million transistors)	Low cost
	High functionality



TABLE 1-continued

Features and Benefits of SoPEC	
Feature	Benefits
900 Million dots per second 10,000 lines per second at 1600 dpi	Extremely fast page generation 0.5 A4/Letter pages per SoPEC chip per second
1 chip drives up to 133,920 nozzles	Low cost page-width printers
1 chip drives up to 6 color planes	99% of SoHo printers can use 1 SoPEC device
Integrated DRAM	No external memory required, leading to low cost systems
Power saving sleep mode	SoPEC can enter a power saving sleep mode to reduce power dissipation between print jobs
JPEG expansion	Low bandwidth from PC Low memory requirements in printer
Lossless bitplane expansion	High resolution text and line art with low bandwidth from PC (e.g. over USB)
Netpage tag expansion	Generates interactive paper
Stochastic dispersed dot dither	Optically smooth image quality No moire effects
Hardware compositor for 6 image planes	Pages composited in real-time
Dead nozzle compensation	Extends printhead life and yield Reduces printhead cost
Color space agnostic	Compatible with all inksets and image sources including RGB, CMYK, spot, CIE L * a * b * , hexachrome, YCrCbK, sRGB and other
Color space conversion	Higher quality/lower bandwidth
Computer interface	USB1.1 interface to host and ISI interface to ISI-Bridge chip thereby allowing connection to IEEE 1394, Bluetooth etc.
Cascadable in resolution	Printers of any resolution
Cascadable in color depth	Special color sets e.g. hexachrome can be used
Cascadable in image size	Printers of any width up to 16 inches
Cascadable in pages	Printers can print both sides simultaneously
Cascadable in speed	Higher speeds are possible by having each SoPEC print one vertical strip of the page.
Fixative channel data generation	Extremely fast ink drying without wastage
Built-in security	Revenue models are protected
Undercolor removal on dot-by- dot basis	Reduced ink usage
Does not require fonts for high speed operation	No font substitution or missing fonts
Flexible printhead configuration	Many configurations of printheads are supported by one chip type
Drives Bi-lithic printheads directly	No print driver chips required, results in lower cost
Determines dot accurate ink usage	Removes need for physical ink monitoring system in ink cartridges

The required printing rate for SoPEC is 30 sheets per minute with an inter-sheet spacing of 4 cm. To achieve a 30 sheets per minute print rate, this requires:

$300 \text{ mm} \times 63 \text{ (dot/mm)} / 2 \text{ sec} = 105.8 \text{ seconds per line, with no inter-sheet gap.}$

$340 \text{ mm} \times 63 \text{ (dot/mm)} / 2 \text{ sec} = 93.3 \text{ seconds per line, with a 4 cm inter-sheet gap.}$

A printline for an A4 page consists of 13824 nozzles across the page. At a system clock rate of 160 MHz 13824 dots of data can be generated in 86.4 seconds. Therefore data can be generated fast enough to meet the printing speed requirement. It is necessary to deliver this print data to the print-heads.

Printheads can be made up of 5:5, 6:4, 7:3 and 8:2 inch printhead combinations [2]. Print data is transferred to both print heads in a pair simultaneously. This means the longest time to print a line is determined by the time to transfer print data to the longest print segment. There are 9744 nozzles across a 7 inch printhead. The print data is transferred to the printhead at a rate of 106 MHz ( $\frac{2}{3}$  of the system clock rate)

per color plane. This means that it will take 91.9 s to transfer a single line for a 7:3 printhead configuration. So we can meet the requirement of 30 sheets per minute printing with a 4 cm gap with a 7:3 printhead combination. There are 11160 across an 8 inch printhead. To transfer the data to the printhead at 106 MHz will take 105.3 s. So an 8:2 printhead combination printing with an inter-sheet gap will print slower than 30 sheets per minute.

From the highest point of view the SoPEC device consists of 3 distinct subsystems

CPU Subsystem

DRAM Subsystem

Print Engine Pipeline (PEP) Subsystem

See FIG. 12 for a block level diagram of SoPEC.

The CPU subsystem controls and configures all aspects of the other subsystems. It provides general support for interfacing and synchronising the external printer with the internal print engine. It also controls the low speed communication to the QA chips. The CPU subsystem contains various peripherals to aid the CPU, such as GPIO (includes motor control),

interrupt controller, LSS Master and general timers. The Serial Communications Block (SCB) on the CPU subsystem provides a full speed USB1.1 interface to the host as well as an Inter SoPEC Interface (ISI) to other SoPEC devices.

The DRAM subsystem accepts requests from the CPU, Serial Communications Block (SCB) and blocks within the PEP subsystem. The DRAM subsystem (in particular the DIU) arbitrates the various requests and determines which request should win access to the DRAM. The DIU arbitrates based on configured parameters, to allow sufficient access to DRAM for all requesters. The DIU also hides the implementation specifics of the DRAM such as page size, number of banks, refresh rates etc.

The Print Engine Pipeline (PEP) subsystem accepts compressed pages from DRAM and renders them to bi-level dots for a given print line destined for a printhead interface that communicates directly with up to 2 segments of a bi-lithic printhead.

The first stage of the page expansion pipeline is the CDU, LBD and TE. The CDU expands the JPEG-compressed contone (typically CMYK) layer, the LBD expands the compressed bi-level layer (typically K), and the TE encodes Netpage tags for later rendering (typically in IR or K ink). The output from the first stage is a set of buffers: the CFU, SFU, and TFU. The CFU and SFU buffers are implemented in DRAM.

The second stage is the HCU, which dithers the contone layer, and composites position tags and the bi-level spot0 layer over the resulting bi-level dithered layer. A number of options exist for the way in which compositing occurs. Up to 6 channels of bi-level data are produced from this stage. Note that not all 6 channels may be present on the printhead. For example, the printhead may be CMY only, with K pushed into the CMY channels and IR ignored. Alternatively, the position tags may be printed in K if IR ink is not available (or for testing purposes).

The third stage (DNC) compensates for dead nozzles in the printhead by color redundancy and error diffusing dead nozzle data into surrounding dots.

The resultant bi-level 6 channel dot-data (typically CMYK-IRF) is buffered and written out to a set of line buffers stored in DRAM via the DWU.

Finally, the dot-data is loaded back from DRAM, and passed to the printhead interface via a dot FIFO. The dot FIFO accepts data from the LLU at the system clock rate (pclk), while the PHI removes data from the FIFO and sends it to the printhead at a rate of  $\frac{2}{3}$  times the system clock rate.

Looking at FIG. 12, the various units are described here in summary form:

TABLE 2

Units within SoPEC			
Subsystem	Unit Acronym	Unit Name	Description
DRAM	DIU	DRAM interface unit	Provides the interface for DRAM read and write access for the various SoPEC units, CPU and the SCB block. The DIU provides arbitration between competing units controls DRAM access.
CPU	DRAM	Embedded DRAM	20 Mbits of embedded DRAM,
	CPU	Central Processing Unit	CPU for system configuration and control
	MMU	Memory Management Unit	Limits access to certain memory address areas in CPU user mode
	RDU	Real-time Debug Unit	Facilitates the observation of the contents of most of the CPU addressable registers in SoPEC in addition to some pseudo-registers in realtime.
	TIM	General Timer	Contains watchdog and general system timers
	LSS	Low Speed Serial Interfaces	Low level controller for interfacing with the QA chips
	GPIO	General Purpose IOs	General IO controller, with built-in Motor control unit, LED pulse units and de-glitch circuitry
	ROM	Boot ROM	16 KBytes of System Boot ROM code
	ICU	Interrupt Controller Unit	General Purpose interrupt controller with configurable priority, and masking.
	CPR	Clock, Power and Reset block	Central Unit for controlling and generating the system clocks and resets and powerdown mechanisms
	PSS	Power Save Storage	Storage retained while system is powered down
	USB	Universal Serial Bus Device	USB device controller for interfacing with the host USB.
	ISI	Inter-SoPEC Interface	ISI controller for data and control communication with other SoPEC's in a multi-SoPEC system
	SCB	Serial Communication Block	Contains both the USB and ISI blocks.



TABLE 2-continued

Units within SoPEC			
Subsystem	Unit Acronym	Unit Name	Description
Print Engine Pipeline (PEP)	PCU	PEP controller	Provides external CPU with the means to read and write PEP Unit registers, and read and write DRAM in single 32-bit chunks.
	CDU	Contone decoder unit	Expands JPEG compressed contone layer and writes decompressed contone to DRAM
	CFU	Contone FIFO Unit	Provides line buffering between CDU and HCU
	LBD	Lossless Bi-level Decoder	Expands compressed bi-level layer.
	SFU	Spot FIFO Unit	Provides line buffering between LBD and HCU
	TE	Tag encoder	Encodes tag data into line of tag dots.
	TFU	Tag FIFO Unit	Provides tag data storage between TE and HCU
	HCU	Half-toner compositor unit	Dithers contone layer and composites the bi-level spot 0 and position tag dots.
	DNC	Dead Nozzle Compensator	Compensates for dead nozzles by color redundancy and error diffusing dead nozzle data into surrounding dots.
	DWU	Dotline Writer Unit	Writes out the 6 channels of dot data for a given printline to the line store DRAM
	LLU	Line Loader Unit	Reads the expanded page image from line store, formatting the data appropriately for the bi-lithic printhead.
	PHI	PrintHead Interface	Is responsible for sending dot data to the bi-lithic printheads and for providing line synchronization between multiple SoPECs. Also provides test interface to printhead such as temperature monitoring and Dead Nozzle Identification.

The CPU block consists of the CPU core, MMU, cache and associated logic. The principal tasks for the program running on the CPU to fulfill in the system are:

#### Communications:

- Control the flow of data from the USB interface to the DRAM and ISI
- Communication with the host via USB or ISI
- Running the USB device driver

#### PEP Subsystem Control:

- Page and band header processing (may possibly be performed on host PC)
- Configure printing options on a per band, per page, per job or per power cycle basis
- Initiate page printing operation in the PEP subsystem
- Retrieve dead nozzle information from the printhead interface (PHI) and forward to the host PC
- Select the appropriate firing pulse profile from a set of predefined profiles based on the printhead characteristics
- Retrieve printhead temperature via the PHI

#### Security:

- Authenticate downloaded program code
- Authenticate printer operating parameters
- Authenticate consumables via the PRINTER\_QA and INK\_QA chips
- Monitor ink usage
- Isolation of OEM code from direct access to the system resources

#### Other:

- Drive the printer motors using the GPIO pins
- Monitoring the status of the printer (paper jam, tray empty etc.)

- Driving front panel LEDs
- Perform post-boot initialisation of the SoPEC device
- Memory management (likely to be in conjunction with the host PC)

#### Miscellaneous housekeeping tasks

- To control the Print Engine Pipeline the CPU is required to provide a level of performance at least equivalent to a 16-bit Hitachi H8-3664 microcontroller running at 16 MHz. An as yet undetermined amount of additional CPU performance is needed to perform the other tasks, as well as to provide the potential for such activity as Netpage page assembly and processing, RIPing etc. The extra performance required is dominated by the signature verification task and the SCB (including the USB) management task. An operating system is not required at present. A number of CPU cores have been evaluated and the LEON P1754 is considered to be the most appropriate solution. A diagram of the CPU block is shown in FIG. 14.

- Memory Management Units are typically used to protect certain regions of memory from invalid accesses, to perform address translation for a virtual memory system and to maintain memory page status (swapped-in, swapped-out or unmapped)

- The SoPEC MMU is a much simpler affair whose function is to ensure that all regions of the SoPEC memory map are adequately protected. The MMU does not support virtual memory and physical addresses are used at all times. The SoPEC MMU supports a full 32-bit address space. The SoPEC memory map is depicted in FIG. 17.

- The MMU selects the relevant bus protocol and generates the appropriate control signals depending on the area of memory being accessed. The MMU is responsible for performing the address decode and generation of the appropriate block select signal as well as the selection of the correct block



read bus during a read access. The MMU will need to support all of the bus transactions the CPU can produce including interrupt acknowledge cycles, aborted transactions etc.

When an MMU error occurs (such as an attempt to access a supervisor mode only region when in user mode) a bus error is generated. While the LEON can recognise different types of bus error (e.g. data store error, instruction access error) it handles them in the same manner as it handles all traps i.e it will transfer control to a trap handler. No extra state information is stored because of the nature of the trap. The location of the trap handler is contained in the TBR (Trap Base Register). This is the same mechanism as is used to handle interrupts.

The DIU provides the interface between the on-chip 20 Mbit embedded DRAM and the rest of SoPEC. In addition to outlining the functionality of the DIU, this chapter provides a top-level overview of the memory storage and access patterns of SoPEC and the buffering required in the various SoPEC blocks to support those access requirements.

The main functionality of the DIU is to arbitrate between requests for access to the embedded DRAM and provide read or write accesses to the requesters. The DIU must also implement the initialisation sequence and refresh logic for the embedded DRAM.

The arbitration scheme uses a fully programmable timeslot mechanism for non-CPU requesters to meet the bandwidth and latency requirements for each unit, with unused slots re-allocated to provide best effort accesses. The CPU is allowed high priority access, giving it minimum latency, but allowing bounds to be placed on its bandwidth consumption.

The interface between the DIU and the SoPEC requesters is similar to the interface on PEC1 i.e. separate control, read data and write data busses.

The embedded DRAM is used principally to store:

CPU program code and data.

PEP (re)programming commands.

Compressed pages containing contone, bi-level and raw tag data and header information.

Decompressed contone and bi-level data.

Dotline store during a print.

Print setup information such as tag format structures, dither matrices and dead nozzle information.

The slots for blocks with a service requirement greater than 1 bit/cycle are distributed as follows. Calculations are included to check that such blocks will not suffer more than one stall per rotation.

The SFU has 2 bits/cycle on read but this is two separate channels of 1 bit/cycle sharing the same DIU interface so it is effectively 2 channels each of 1 bit/cycle so allowing the same margins as the LBD will work.

The DWU has 12 double buffers in each of the 6 colour planes, odd and even. These buffers are filled by the DNC and will request DIU access when double buffers fill. The DNC supplies 6 bits to the DWU every cycle (6 odd in one cycle, 6 even in the next cycle). So the service deadline is 512 cycles, given 6 accesses per 256-cycle rotation.

For the CFU the requirement is that the DIU stall should be less than the time taken for the CFU to consume one third of its triple buffer. The total DIU stall=refresh latency+extra CDU(W) latency+read circuit latency=3+5 (for 4 cycle timeslots)+10=18 cycles. The CFU can consume its data at 8 bits/cycle at SF=4. Therefore 256 bits of data will last 32 cycles so the triple buffer is safe. In fact we only need an extra 144 bits of buffering or 3×64 bits. But it is safer to have the full extra 256 bits or 4×64 bits of buffering.

The LLU has 2 channels, each of which could request at 6 bits/106 MHz channel or 4 bits/160 MHz cycle, giving a total of 8 bits/160 MHz cycle. The service deadline for each chan-

nel is 256×106 MHz cycles, i.e. all 6 colours must be transferred in 256 cycles to feed the printhead. This equates to 384×160 MHz cycles.

Over a span of 384 cycles, there will be 6 CDU(W) accesses, 4 refreshes and one read latency encountered at most. Assuming CPU pre-accesses for these occurrences, this means the number of available cycles is given by  $384 - 6 \times 6 - 4 \times 6 - 10 = 314$  cycles.

For a CPU pre-access slot rate of 50%, 314 cycles implies 31 CPU and 63 non-CPU accesses ( $31 \times 6 + 32 \times 4 = 314$ ). For 12 LLU accesses interspersed amongst these 63 non-CPU slots, implies an LLU allocation rate of approximately one slot in 5.

If the CPU pre-access is 100% across all slots, then 314 cycles gives 52 slots each to CPU and non-CPU accesses, ( $52 \times 6 = 312$  cycles). Twelve accesses spread over 52 slots, implies a 1-in-4 slot allocation to the LLU.

The same LLU slot allocation rate (1 slot in 5, or 1 in 4) can be applied to programming slots across a 256-cycle rotation window. The window size does not affect the occurrence of LLU slots, so the 384-cycle service requirement will be fulfilled.

The DNC has a 2.4 bits/cycle bandwidth requirement. Each access will see the DIU stall of 18 cycles. 2.4 bits/cycle corresponds to an access every 106 cycles within a 256 cycle rotation. So to allow for DIU latency we need an access every 106-18 or 88 cycles. This is a bandwidth of 2.9 bits/cycle, requiring 3 timeslots in the rotation.

The Dotline Writer Unit (DWU) receives 1 dot (6 bits) of color information per cycle from the DNC. Dot data received is bundled into 256-bit words and transferred to the DRAM.

The DWU (in conjunction with the LLU) implements a dot line FIFO mechanism to compensate for the physical placement of nozzles in a printhead, and provides data rate smoothing to allow for local complexities in the dot data generate pipeline.

The physical placement of nozzles in the printhead means that in one firing sequence of all nozzles, dots will be produced over several print lines. The printhead consists of 12 rows of nozzles, one for each color of odd and even dots. Odd and even nozzles are separated by  $D_2$  print lines and nozzles of different colors are separated by  $D_1$  print lines. See FIG. 19 for reference. The first color to be printed is the first row of nozzles encountered by the incoming paper. In the example this is color 0 odd, although is dependent on the printhead type. Paper passes under printhead moving downwards.

For example if the physical separation of each half row is 80 m equating to  $D_1 = D_2 = 5$  print lines at 1600 dpi. This means that in one firing sequence, color 0 odd nozzles will fire on dotline L, color 0 even nozzles will fire on dotline L- $D_1$ , color 1 odd nozzles will fire on dotline L- $D_1$ - $D_2$  and so on over 6 color planes odd and even nozzles. The total number of lines fired over is given as  $0+5+5 \dots +5=0+11 \times 5=55$ . See FIG. 20 for example diagram. It is expected that the physical spacing of the printhead nozzles will be 80 m (or 5 dot lines), although there is no dependency on nozzle spacing. The DWU is configurable to allow other line nozzle spacings.

The DWU block is required to compensate for the physical spacing between lines of nozzles. It does this by storing dot lines in a FIFO (in DRAM) until such time as they are required by the LLU for dot data transfer to the printhead interface. Colors are stored separately because they are needed at different times by the LLU. The dot line store must store enough lines to compensate for the physical line separation of the printhead but can optionally store more lines to allow system level data rate variation between the read (printhead feed) and write sides (dot data generation pipeline) of the FIFOs.

A logical representation of the FIFOs is shown in FIG. 21, where N is defined as the optional number of extra half lines



in the dot line store for data rate de-coupling. For an arbitrary page width of  $d$  dots (where  $d$  is even), the number of dots per half line is  $d/2$ .

For interline spacing of  $D_2$  and inter-color spacing of  $D_1$ , with  $C$  colors of odd and even half lines, the number of half line storage is  $(C-1)(D_2+D_1)+D_1$ .

For  $N$  extra half line stores for each color odd and even, the storage is given by  $(N*C*2)$ . The total storage requirement is  $((C-1)(D_2+D_1)+D_1+(N*C*2))*d/2$  in bits.

Note that when determining the storage requirements for the dot line store, the number of dots per line is the page width and not necessarily the printhead width. The page width is often the dot margin number of dots less than the printhead width. They can be the same size for full bleed printing.

For example in an A4 page a line consists of 13824 dots at 1600 dpi, or 6912 dots per half dot line. To store just enough dot lines to account for an inter-line nozzle spacing of 5 dot lines it would take 55 half dot lines for color 5 odd, 50 dot lines for color 5 even and so on, giving  $55+50+45 \dots 10+5+0=330$  half dot lines in total. If it is assumed that  $N=4$  then the storage required to store 4 extra half lines per color is  $4 \times 12=48$ , in total giving  $330+48=378$  half dot lines. Each half dot line is 6912 dots, at 1 bit per dot give a total storage requirement of  $6912 \text{ dots} \times 378 \text{ half dot lines} / 8 \text{ bits} = \text{Approx } 319 \text{ Kbytes}$ . Similarly for an A3 size page with 19488 dots per line,  $9744 \text{ dots per half line} \times 378 \text{ half dot lines} / 8 = \text{Approx } 899 \text{ Kbytes}$ .

The potential size of the dot line store makes it unfeasible to be implemented in on-chip SRAM, requiring the dot line store to be implemented in embedded DRAM. This allows a configurable dotline store where unused storage can be redistributed for use by other parts of the system.

Due to construction limitations of the bi-lithic printhead it is possible that nozzle rows may be misaligned relative to each other. Odd and even rows, and adjacent color rows may be horizontally misaligned by up to 2 dot positions. Vertical misalignment can also occur but is compensated for in the LLU and not considered here. The DWU is required to compensate for the horizontal misalignment.

Dot data from the HCU (through the DNC) produces a dot of 6 colors all destined for the same physical location on paper. If the nozzle rows in the printhead are aligned as shown in FIG. 19 then no adjustment of the dot data is needed.

A conceptual misaligned printhead is shown in FIG. 22. The exact shape of the row alignment is arbitrary, although is most likely to be sloping (if sloping, it could be sloping in either direction).

The DWU is required to adjust the shape of the dot streams to take account of the join between printhead ICs. The introduction of the join shape before the data is written to the DRAM means that the PHI sees a single crossover point in the data since all lines are the same length and the crossover point (since all rows are of equal length) is a vertical line—i.e. the crossover is at the same time for all even rows, and at the same time for all odd rows as shown in FIG. 23.

To insert the shape of the join into the dot stream, for each line we must first insert the dots for non-printable area 1, then the printable area data (from the DNC), and then finally the dots for non-printable area 2. This can also be considered as: first produce the dots for non-printable area 1 for line  $n$ , and then a repetition of:

produce the dots for the printable area for line  $n$  (from the DNC)

produce the dots for the non-printable area 2 (for line  $n$ ) followed by the dots of non-printable area 1 (for line  $n+1$ )

The reason for considering the problem this way is that regardless of the shape of the join, the shape of non-printable area 2 merged with the shape of non-printable area 1 will always be a rectangle since the widths of non-printable areas 1 and 2 are identical and the lengths of each row are identical. Hence step 2 can be accomplished by simply inserting a constant number ( $\text{MaxNozzleSkew}$ ) of 0 dots into the stream.

For example, if the color  $n$  even row non-printable area 1 is of length  $X$ , then the length of color  $n$  even row non-printable area 2 will be of length  $\text{MaxNozzleSkew}-X$ . The split between non-printable areas 1 and 2 is defined by the  $\text{NozzleSkew}$  registers.

Data from the DNC is destined for the printable area only, the DWU must generate the data destined for the non-printable areas, and insert DNC dot data correctly into the dot data stream before writing dot data to the fifos. The DWU inserts the shape of the misalignment into the dot stream by delaying dot data destined to different nozzle rows by the relative misalignment skew amount.

An embedded DRAM is expected to be of the order of 256 bits wide, which results in 27 words per half line of an A4 page, and 54 words per half line of A3. This requires 27 words  $\times$  12 half colors (6 colors odd and even) = 324  $\times$  256-bit DRAM accesses over a dotline print time, equating to 6 bits per cycle (equal to DNC generate rate of 6 bits per cycle). Each half color is required to be double buffered, while filling one buffer the other buffer is being written to DRAM. This results in 256 bits  $\times$  2 buffers  $\times$  12 half colors i.e. 6144 bits in total.

The buffer requirement can be reduced, by using 1.5 buffering, where the DWU is filling 128 bits while the remaining 256 bits are being written to DRAM. While this reduces the required buffering locally it increases the peak bandwidth requirement to the DRAM. With 2  $\times$  buffering the average and peak DRAM bandwidth requirement is the same and is 6 bits per cycle, alternatively with 1.5  $\times$  buffering the average DRAM bandwidth requirement is 6 bits per cycle but the peak bandwidth requirement is 12 bits per cycle. The amount of buffering used will depend on the DRAM bandwidth available to the DWU unit.

Should the DWU fail to get the required DRAM access within the specified time, the DWU will stall the DNC data generation. The DWU will issue the stall in sufficient time for the DNC to respond and still not cause a FIFO overrun. Should the stall persist for a sufficiently long time, the PHI will be starved of data and be unable to deliver data to the printhead in time. The sizing of the dotline store FIFO and internal FIFOs should be chosen so as to prevent such a stall happening.

The dot data shift register order in the printhead is shown in FIG. 19 (the transmit order is the opposite of the shift register order). In the example the type 0 printhead IC transmit order is increasing even color data followed by decreasing odd color data. The type 1 printhead IC transmit order is decreasing odd color data followed by increasing even color data. For both printhead ICs the even data is always increasing order and odd data is always decreasing. The PHI controls which printhead IC data gets shifted to.

From this it is beneficial to store even data in increasing order in DRAM and odd data in decreasing order. While this order suits the example printhead, other printheads exist where it would be beneficial to store even data in decreasing order, and odd data in increasing order, hence the order is configurable. The order that data is stored in memory is controlled by setting the  $\text{ColorLineSense}$  register.

The dot order in DRAM for increasing and decreasing sense is shown in FIG. 25 and FIG. 26 respectively. For each



line in the dot store the order is the same (although for odd lines the numbering will be different the order will remain the same). Dot data from the DNC is always received in increasing dot number order. For increasing sense dot data is bundled into 256-bit words and written in increasing order in DRAM, word 0 first, then word 1, and so on to word N, where N is the number of words in a line.

For decreasing sense dot data is also bundled into 256-bit words, but is written to DRAM in decreasing order, i.e. word N is written first then word N-1 and so on to word 0. For both increasing and decreasing sense the data is aligned to bit 0 of a word, i.e. increasing sense always starts at bit 0, decreasing sense always finishes at bit 0.

Each half color is configured independently of any other color. The ColorBaseAdr register specifies the position where data for a particular dotline FIFO will begin writing to. Note that for increasing sense colors the ColorBaseAdr register specifies the address of the first word of first line of the fifo, whereas for decreasing sense colors the ColorBaseAdr register specifies the address of last word of the first line of the FIFO.

Dot data received from the DNC is bundled in 256-bit words and transferred to the DRAM. Each line of data is stored consecutively in DRAM, with each line separated by ColorLineInc number of words.

For each line stored in DRAM the DWU increments the line count and calculates the DRAM address for the next line to store.

This process continues until ColorFifoSize number of lines are stored, after which the DRAM address will wrap back to the ColorBaseAdr address.

As each line is written to the FIFO, the DWU increments the FifoFillLevel register, and as the LLU reads a line from the FIFO the FifoFillLevel register is decremented. The LLU indicates that it has completed reading a line by a high pulse on the llu\_dw\_u\_line\_rd line. When the number of lines stored in the FIFO is equal to the MaxWriteAhead value the DWU will indicate to the DNC that it is no longer able to receive data (i.e. a stall) by deasserting the dwu\_dnc\_ready signal.

The ColorEnable register determines which color planes should be processed, if a plane is turned off, data is ignored for that plane and no DRAM accesses for that plane are generated.

The dot line FIFOs when accessed by the LLU are specified differently than when accessed by the DWU. The DWU uses a start address and number of lines value to specify a dot FIFO, the LLU uses a start and end address for each dot FIFO. The mechanisms differ to allow more efficient implementations in each block.

As a result of limitations in the LLU the dot FIFOs must be specified contiguously and increasing in DRAM.

The Line Loader Unit (LLU) reads dot data from the line buffers in DRAM and structures the data into even and odd dot channels destined for the same print time. The blocks of dot data are transferred to the PHI and then to the printhead. FIG. 32 shows a high level data flow diagram of the LLU in context.

The DWU re-orders dot data into 12 separate dot data line FIFOs in the DRAM. Each FIFO corresponds to 6 colors of odd and even data. The LLU reads the dot data line FIFOs and sends the data to the printhead interface. The LLU decides when data should be read from the dot data line FIFOs to correspond with the time that the particular nozzle on the printhead is passing the current line. The interaction of the DWU and LLU with the dot line FIFOs compensates for the physical spread of nozzles firing over several lines at once.

FIG. 33 shows the physical relationship of nozzle rows and the line time the LLU starts reading from the dot line store.

Within each line of dot data the LLU is required to generate an even and odd dot data stream to the PHI block. FIG. 34 shows the even and dot streams as they would map to an example bi-lithic printhead. The PHI block determines which stream should be directed to which printhead IC.

The structure of the printhead ICs dictate the dot transmit order to each printhead IC. The LLU reads data from the dot line FIFO, generates an even and odd dot stream which is then re-ordered (in the PHI) into the transmit order for transfer to the printhead.

The DWU separates dot data into even and odd half lines for each color and stores them in DRAM. It can store odd or even dot data in increasing or decreasing order in DRAM. The order is programmable but for descriptive purposes assume even in increasing order and odd in decreasing order. The dot order structure in DRAM is shown in FIG. 26.

The LLU contains 2 dot generator units. Each dot generator reads dot data from DRAM and generates a stream of odd or even dots. The dot order may be increasing or decreasing depending on how the DWU was programmed to write data to DRAM. An example of the even and odd dot data streams to DRAM is shown in FIG. 35. In the example the odd dot generator is configured to produce odd dot data in decreasing order and the even dot generator produces dot data in increasing order.

The PHI block accepts the even and odd dot data streams and reconstructs the streams into transmit order to the printhead.

The LLU line size refers to the page width in dots and not necessarily the printhead width. The page width is often the dot margin number of dots less than the printhead width. They can be the same size for full bleed printing.

At the start of a page the LLU must wait for the dot line store in DRAM to fill to a configured level (given by FifoReadThreshold) before starting to read dot data. Once the LLU starts processing dot data for a page it must continue until the end of a page, the DWU (and other PEP blocks in the pipeline) must ensure there is always data in the dot line store for the LLU to read, otherwise the LLU will stall, causing the PHI to stall and potentially generate a print error. The FifoReadThreshold should be chosen to allow for data rate mismatches between the DWU write side and the LLU read side of the dot line FIFO. The LLU will not generate any dot data until FifoReadThreshold level in the dot line FIFO is reached.

Once the FifoReadThreshold is reached the LLU begins page processing, the FifoReadThreshold is ignored from then on.

When the LLU begins page processing it produces dot data for all colors (although some dot data color may be null data). The LLU compares the line count of the current page, when the line count exceeds the ColorRelLine configured value for a particular color the LLU will start reading from that color's FIFO in DRAM. For colors that have not exceeded the ColorRelLine value the LLU will generate null data (zero data) and not read from DRAM for that color. ColorRelLine[N] specifies the number of lines separating the N<sup>th</sup> half color and the first half color to print on that page.

For the example printhead shown in FIG. 33, color 0 odd will start at line 0, the remaining colors will all have null data. Color 0 odd will continue with real data until line 5, when color 0 odd and even will contain real data the remaining colors will contain null data. At line 10, color 0 odd and even and color 1 odd will contain real data, with remaining colors containing null data. Every 5 lines a new half color will contain real data and the remaining half colors null data until



line 55, when all colors will contain real data. In the example ColorRelLine[0]=5, ColorRelLine[1]=0, ColorRelLine[2]=15, ColorRelLine[3]=10 . . . etc.

It is possible to turn off any one of the color planes of data (via the ColorEnable register), in such cases the LLU will generate zeroed dot data information to the PHI as normal but will not read data from the DRAM.

The LLU is required to generate data for feeding to the printhead interface, the rate required is dependent on the printhead construction and on the line rate configured. The maximum data rate the LLU can produce is 12 bits of dot data per cycle, but the PHI consumes at 12 bits every 2 pclk cycles out of 3, i.e. 8 bits per pclk cycle. Therefore the DRAM bandwidth requirement for a double buffered LLU is 8 bits per cycle on average. If 1.5 buffering is used then the peak bandwidth requirement is doubled to 16 bits per cycle but the average remains at 8 bits per cycle. Note that while the LLU and PHI could produce data at the 8 bits per cycle rate, the DWU can only produce data at 6 bits per cycle rate.

Due to construction limitations of the bi-lithic printhead it is possible that nozzle rows may be misaligned relative to each other. Odd and even rows, and adjacent color rows may be horizontally misaligned by up to 2 dot positions. Vertical misalignment can also occur between both printhead ICs used to construct the printhead. The DWU compensates for the horizontal misalignment, and the LLU compensates for the vertical misalignment. For each color odd and even the LLU maintains 2 pointers into DRAM, one for feeding printhead A (CurrentPtrA) and other for feeding printhead B (CurrentPtrB). Both pointers are updated and incremented in exactly the same way, but differ in their initial value programming. They differ by vertical skew number of lines, but point to the same relative position within a line.

At the start of a line the LLU reads from the FIFO using CurrentPtrA until the join point between the printhead ICs is reached (specified by JoinPoint), after which the LLU reads from DRAM using CurrentPtrB. If the JoinPoint coincides with a 256-bit word boundary, the swap over from pointer A to pointer B is straightforward. If the JoinPoint is not on a 256-bit word boundary, the LLU must read the 256-bit word of data from CurrentPtrA location, generate the dot data up to the join point and then read the 256-bit word of data from CurrentPtrB location and generate dot data from the join point to the word end. This means that if the JoinPoint is not on a 256-bit boundary then the LLU is required to perform an extra read from DRAM at the join point and not increment the address pointers. For each dot line FIFO there are 2 pointers reading from it, each skewed by a number of dot lines in relation to the other (the skew amount could be positive or negative). Determining the exact number of valid lines in the dot line store is complicated by two pointers reading from different positions in the FIFO. It is convenient to remove the problem by pre-zeroing the dot line FIFOs effectively removing the need to determine exact data validity. The dot FIFOs can be initialized in a number of ways, including

- the CPU writing 0s,
- the LBD/SFU writing a set of 0 lines (16 bits per cycle),
- the HCU/DNC/DWU being programmed to produce 0 data

The dot line FIFOs when accessed by the LLU are specified differently than when accessed by the DWU. The DWU uses a start address and number of lines value to specify a dot FIFO, the LLU uses a start and end address for each dot FIFO. The mechanisms differ to allow more efficient implementations in each block.

The start address for each half color N is specified by the ColorBaseAdr[N] registers and the end address (actually the end address plus 1) is specified by the ColorBaseAdr[N+1].

Note there are 12 colors in total, 0 to 11, the ColorBaseAdr [12] register specifies the end of the color 11 dot FIFO and not the start of a new dot FIFO. As a result the dot FIFOs must be specified contiguously and increasing in DRAM.

The dot generator block is responsible for reading dot data from the DIU buffers and sending the dot data in the correct order to the PHI block. The dot generator waits for llu\_en signal from the fifo fill level block, once active it starts reading data from the 6 DIU buffers and generating dot data for feeding to the PHI.

In the LLU there are two instances of the dot generator, one generating odd data and the other generating even data.

At any time the ready bit from the PHI could be de-asserted, if this happens the dot generator will stop generating data, and wait for the ready bit to be re-asserted.

The Printhead interface (PHI) accepts dot data from the LLU and transmits the dot data to the printhead, using the printhead interface mechanism. The PHI generates the control and timing signals necessary to load and drive the bi-lithic printhead. The CPU determines the line update rate to the printhead and adjusts the line sync frequency to produce the maximum print speed to account for the printhead IC's size ratio and inherent latencies in the syncing system across multiple SoPECs.

The PHI also needs to consider the order in which dot data is loaded in the printhead. This is dependent on the construction of the printhead and the relative sizes of printhead ICs used to create the printhead.

The printing process is a real-time process. Once the printing process has started, the next printline's data must be transferred to the printhead before the next line sync pulse is received by the printhead. Otherwise the printing process will terminate with a buffer underrun error.

The PHI can be configured to drive a single printhead IC with or without synchronization to other SoPECs. For example the PHI could drive a single IC printhead (i.e. a printhead constructed with one IC only), or dual IC printhead with one SoPEC device driving each printhead IC.

The PHI interface provides a mechanism for the CPU to directly control the PHI interface pins, allowing the CPU to access the bi-lithic printhead to:

- determine printhead temperature
- test for and determine dead nozzles for each printhead IC
- initialize each printhead IC
- pre-heat each printhead IC

FIG. 42 shows a high level data flow diagram of the PHI in context.

The LLU can generate dot data at the rate of 12 bits per cycle, where a cycle is at the system clock frequency. In order to achieve the target print rate of 30 sheets per minute, the printhead needs to print a line every 100 s (calculated from 300 mm @65.2 dots/mm divided by 2 seconds= $\sim$ 100 sec). For a 7:3 constructed printhead this means that 9744 cycles at 320 Mhz is quick enough to transfer the 6-bit dot data (at 2 bits per cycle). The input FIFOs are used to de-couple the read and write clock domains as well as provide for differences between consume and fill rates of the PHI and LLU.

Nominally the system clock (pclk) is run at 160 Mhz and the printhead interface clock (doclk) is at 320 Mhz.

If the PHI was to transfer data at the full printhead interface rate, the transfer of data to the shorter printhead IC would be completed sooner than the longer printhead IC. While in itself this isn't an issue it requires that the LLU be able to supply data at the maximum rate for short duration, this requires uneven bursty access to DRAM which is undesirable. To smooth the LLU DRAM access requirements over time the



PHI transfers dot data to the printhead at a pre-programmed rate, proportional to the ratio of the shorter to longer printhead ICs.

The printhead data rate equalization is controlled by Print-HeadRate[1:0] registers (one per printhead IC). The register is a 16 bit bitmap of active clock cycles in a 16 clock cycle window. For example if the register is set to 0xFFFF then the output rate to the printhead will be full rate, if it's set to 0xF0F0 then the output rate is 50% where there is 4 active cycles followed by 4 inactive cycles and so on. If the register was set to 0x0000 the rate would be 0%. The relative data transfer rate of the printhead can be varied from 0-100% with a granularity of  $1/16$  steps.

TABLE 3

Example rate equalization values for common printheads		
Printhead Ratio A:B	Printhead A rate (%)	Printhead B rate (%)
8:2	0xFFFF (100%)	0x1111 (25%)
7:3	0xFFFF (100%)	0x5551 (43.7%)
6:4	0xFFFF (100%)	0xF1F2 (68.7%)
5:5	0xFFFF (100%)	0xFFFF (100%)

If both printhead ICs are the same size (e.g. a 5:5 printhead) it may be desirable to reduce the data rate to both printhead ICs, to reduce the read bandwidth from the DRAM. Several printhead types and arrangements exists. The PHI is capable

of driving all possible configurations, but for the purposes of simplicity only one arrangement is described in the following examples.

The structure of the printhead ICs dictate the dot transmit order to each printhead IC. The PHI accepts two streams of dot data from the LLU, one even stream the other odd. The PHI constructs the dot transmit order streams from the dot generate order received from the LLU. Each stream of data has already been arranged in increasing or decreasing dot order sense by the DWU. The exact sense choice is dependent on the type of printhead ICs used to construct the printhead, but regardless of configuration the odd and even stream should be of opposing sense.

The dot transmit order is shown in FIG. 46. Dot data is shifted into the printhead in the direction of the arrow, so from the diagram (taking the type 0 printhead IC) even dot data is transferred in increasing order to the mid point first (0, 2, 4, . . . , m-6, m-4, m-2), then odd dot data in decreasing order is transferred (m-1, m-3, m-5 . . . , 5, 3, 1). For the type 1 printhead IC the order is reversed, with odd dots in increasing order transmitted first, followed by even dot data in decreasing order. Note for any given color the odd and even dot data transferred to the printhead ICs are from different dot lines, in the example in the diagram they are separated by 5 dot lines. Table 4 shows the transmit dot order for some common A4 printheads. Different type printheads may have the sense reversed and may have an odd before even transmit order or vice versa.

TABLE 4

Example printhead ICs, and dot data transmit order for A4 (13824 dots) page		
Size	Dots	Dot Order
Type 0 Printhead IC		
8	11160 0, 2, 4, 8 . . . , 5574, 5576, 5578	5579, 5577, 5575 . . . 7, 5, 3, 1
7	9744 0, 2, 4, 8 . . . , 4866, 4868, 4870	4871, 4869, 4867 . . . 7, 5, 3, 1
6	8328 0, 2, 4, 8 . . . , 4158, 4160, 4162	4163, 4161, 4159 . . . 7, 5, 3, 1
5	6912 0, 2, 4, 8 . . . , 3450, 3452, 3454	3455, 3453, 3451 . . . 7, 5, 3, 1
4	5496 0, 2, 4, 8 . . . , 2742, 2744, 2746	2847, 2845, 2843 . . . 7, 5, 3, 1
3	4080 0, 2, 4, 8 . . . , 2034, 2036, 2038	2039, 2037, 2035 . . . 7, 5, 3, 1
2	2664 0, 2, 4, 8 . . . , 1326, 1328, 1330	1331, 1329, 1327 . . . 7, 5, 3, 1
Type 1 Printhead IC		
8	11160 13823, 13821, 13819 . . . , 1337, 1335, 1333	1332, 1334, 1336 . . . 13818, 13820, 13822
7	9744 13823, 13821, 13819 . . . , 2045, 2043, 2041	2040, 2042, 2044 . . . 13818, 13820, 13822
6	8328 13823, 13821, 13819 . . . , 2853, 2851, 2849	2848, 2850, 2852 . . . 13818, 13820, 13822
5	6912 13823, 13821, 13819 . . . , 3461, 3459, 3457	3456, 3458, 3460 . . . 13818, 13820, 13822
4	5496 13823, 13821, 13819 . . . , 4169, 4167, 4165	4164, 4166, 4168 . . . 13818, 13820, 13822
3	4080 13823, 13821, 13819 . . . , 4877, 4875, 4873	4872, 4874, 4876 . . . 13818, 13820, 13822
2	2664 13823, 13821, 13819 . . . , 5585, 5583, 5581	5580, 5582, 5584 . . . 13818, 13820, 13822



The LLU contains 2 dot generator units. Each dot generator reads dot data from DRAM and generates a stream of dots in increasing or decreasing order. A dot generator can be configured to produce odd or even dot data streams, and the dot sense is also configurable. In FIG. 46 the odd dot generator is configured to produce odd dot data in decreasing order and the even dot generator produces dot data in increasing order. The LLU takes care of any vertical misalignment between the 2 printhead ICs, presenting the PHI with the appropriate data ready to be transmitted to the printhead.

In order to reconstruct the dot data streams from the generate order to the transmit order, the connection between the generators and transmitters needs to be switched at the mid point. At line start the odd dot generator feeds the type 1 printhead, and the even dot generator feeds the type 0 printhead. This continues until both printheads have received half the number of dots they require (defined as the mid point). The mid point is calculated from the configured printhead size registers (PrintHeadSize). Once both printheads have reached the mid point, the PHI switches the connections between the dot generators and the printhead, so now the odd dot generator feeds the type 0 printhead and the even dot generator feeds the type 1 printhead. This continues until the end of the line.

It is possible that both printheads will not be the same size and as a result one dot generator may reach the mid point before the other. In such cases the quicker dot generator is stalled until both dot generators reach the mid point, the connections are switched and both dot generators are restarted.

Note that in the example shown in FIG. 46 the dot generators could generate an A4 line of data in 6912 cycles, but because of the mismatch in the printhead IC sizes the transmit time takes 9744 cycles.

In some cases only one printhead IC may be connected to the PHI. In FIG. 47 the dot generate and transmit order is shown for a single IC printhead of 9744 dots width. While the example shows the printhead IC connected to channel A, either channel could be used. The LLU generates odd and even dot streams as normal, it has no knowledge of the physical printhead configuration. The PHI is configured with the printhead size (PrintHeadSize[1] register) for channel B set to zero and channel A is set to 9744. Note that in the example shown in FIG. 48 the dot generators could generate an 7 inch line of data in 4872 cycles, but because the printhead is using one IC, the transmit time takes 9744 cycles, the same speed as an A4 line with a 7:3 printhead.

In order to support all the possible printhead arrangements, the PHI (in conjunction with the LLU/DWU) must be capable of re-ordering the bits according to the following criteria:

Be able to output the even or odd plane first.

Be able to output even and odd planes independently.

Be able to reverse the sequence in which the color planes of a single dot are output to the printhead.

The PHI is responsible for accepting dot data streams from the LLU, restructuring the dot data sequence and transferring the dot data to each printhead within a line time (i.e before the next line sync).

Before a page can be printed the printhead ICs must be initialized. The exact initialization sequence is configuration

dependent, but will involve the fire pattern generation initialization and other optional steps. The initialization sequence is implemented in software.

Once the first line of data has been transferred to the printhead, the PHI will interrupt the CPU by asserting the phi\_icu\_print\_rdy signal. The interrupt can be optionally masked in the ICU and the CPU can poll the signal via the PCU or the ICU. The CPU must wait for a print ready signal in all printing SoPECs before starting printing.

Once the CPU in the PrintMaster SoPEC is satisfied that printing should start, it triggers the LineSyncMaster SoPEC by writing to the PrintStart register of all printing SoPECs. The transition of the PrintStart register in the LineSyncMaster SoPEC will trigger the start of lsync pulse generation. The PrintMaster and LineSyncMaster SoPEC are not necessarily the same device, but often are the same.

Writing a 1 to the PrintStart register enables the generation of the line sync in the LineSyncMaster which is in turn used to align all SoPECs in a multi-SoPEC system. All printhead signaling is aligned to the line sync. The PrintStart is only used to align the first line sync in a page.

When a SoPEC receives a line sync pulse it means that the line previously transferred to the printhead is now printing, so the PHI can begin to transfer the next line of data to the printhead. When the transfer is complete the PHI will wait for the next line sync pulse before repeating the cycle. If a line sync arrives before a complete line is transferred to the printhead (i.e. a buffer error) the PHI generates a buffer underrun interrupt, and halts the block.

For each line in a page the PHI must transfer a full line of data to the printhead before the next line sync is generated or received.

If the PHI is configured as the LineSyncMaster SoPEC it will start generating line sync signals LsyncPre number of pclk cycles after PrintStart register rising transition is detected.

All other signals in the PHI interface are referenced from the rising edge of phi\_ksync signal.

If the SoPEC is in line sync slave mode it will receive a line sync pulse from the LineSyncMaster SoPEC through the phi\_ksync pin which will be programmed into input mode. The phi\_ksync input pin is treated as an asynchronous input and is passed through a de-glitch circuit of programmable de-glitch duration (LsyncDeglitchCnt).

The phi\_ksync will remain low for LsyncLow cycles, and then high for LsyncHigh cycles. The phi\_ksync profile is repeated until the page is complete. The period of the phi\_ksync is given by LsyncLow+LsyncHigh cycles. Note that the LsyncPre value is only used to vary the time between the generation of the first phi\_ksync and the PageStart indication from the CPU. See FIG. 49 for reference diagram.

If the SoPEC device is in line sync slave mode, the LsyncHigh register specifies the minimum allowed phi\_ksync period. Any phi\_ksync pulses received before the LsyncHigh has expired will trigger a buffer underrun error.

Once the PHI receives the line sync pulse, the sequence of data transfer to the printhead begins. All PHI control signals are specified from the rising edge of the line sync. The phi\_srelk (and consequently phi\_ph\_data) is controlled by the SrelkPre, SrelkPost registers. The SrelkPre specifies the number of pclk cycles to wait before beginning to transfer data to



the printhead. Once data transfer has started, the profile of the phi\_srclk is controlled by PrintHeadRate register and the status of the PHI input FIFO. For example it is possible that the input FIFO could empty and no data would be transferred to the printhead while the PHI was waiting. After all the data for a printhead is transferred to the PHI, it counts SrclkPost number of pclk cycles. If a new phi\_ksync falling edge arrives before the count is complete the PHI will generate a buffer underrun interrupt (phi\_icu\_underrun).

The profile of the phi\_frclk pulses per line is determined by 4 registers FrclkPre, FrclkLow, FrclkHigh, FrclkNum. The FrclkPre register specifies the number of cycles between line sync rising edge and the phi\_frclk pulse high. It remains high for FrclkHigh cycles and then low for FrclkLow cycles. The number of pulses generated per line is determined by FrclkNum register.

The total number of cycles required to complete a firing sequence should be less than the phi\_ksync period i.e.  $((FrclkHigh + FrclkLow) * FrclkNum) + FrclkPre < (LsyncLow + LsyncHigh)$ .

Note that when in CPU direct control mode (PrintHeadCpuCtrl=1) and PrintHeadCpuCtrlMode[x]=1, the frclk generator is triggered by the transition of the FireGenSoftTrigger [0] bit from 0 to 1.

FIG. 49 details the timing parameters controlling the PHI. All timing parameters are measured in number of pclk cycles.

The PHI counts the number of lines processed through the interface. The line count is initialised to the PageLenLine and decrements each time a line is processed. When the line count is zero it pulses the phi\_icu\_page\_finish signal. A pulse on the phi\_icu\_page\_finish automatically resets the PHI Go register, and can optionally cause an interrupt to the CPU. Should the page terminate abnormally, i.e. a buffer underrun, the Go register will be reset and an interrupt generated.

The PHI will generate an interrupt to the CPU after a predefined number of line syncs have occurred. The number of line syncs to count is configured by the LineSyncInterrupt register. The interrupt can be disabled by setting the register to zero.

The PHI block allows the generation of margins either side of the received page from the LLU block. This allows the page width used within PEP blocks to differ from the physical printhead size.

This allows SoPEC to store data for a page minus the margins, resulting in less storage requirements in the shared DRAM and reduced memory bandwidth requirements. The difference between the dot data line size and the line length generated by the PHI is the dot line margin length. There are two margins specified for any sheet, a margin per printhead IC side.

The margin value is set by programming the DotMargin register per printhead IC. It should be noted that the DotMargin register represents half the width of the actual margin (either left or right margin depending on paper flow direction). For example, if the margin in dots is 1 inch (1600 dots), then DotMargin should be set to 800. The reason for this is that the PHI only supports margin creation cases 1 and 3 described below.

See example in FIG. 49.

In the example the margin for the type 0 printhead IC is set at 100 dots (DotMargin==100), implying an actual margin of 200 dots.

If case one is used the PHI takes a total of 9744 phi\_srclk cycles to load the dot data into the type 0 printhead. It also requires 9744 dots of data from the LLU which in turn gets read from the DRAM. In this case the first 100 and last 100 dots would be zero but are processed though the SoPEC system consuming memory and DRAM bandwidth at each step.

In case 2 the LLU no longer generates the margin dots, the PHI generates the zeroed out dots for the margining. The phi\_srclk still needs to toggle 9744 times per line, although the LLU only needs to generate 9544 dots giving the reduction in DRAM storage and associated bandwidth. The case 2 scenario is not supported by the PHI because the same effect can be supported by means of case 1 and case 3.

If case 3 is used the benefits of case 2 are achieved, but the phi\_srclk no longer needs to toggle the full 9744 clock cycles. The phi\_srclk cycles count can be reduced by the margin amount (in this case  $9744 - 100 = 9644$  dots), and due to the reduction in phi\_srclk cycles the phi\_ksync period could also be reduced, increasing the line processing rate and consequently increasing print speed. Case 3 works by shifting the odd (or even) dots of a margin from line Y to become the even (or odd) dots of the margin for line Y-4, (Y-5 adjusted due to being printed one line later). This works for all lines with the exception of the first line where there has been no previous line to generate the zeroed out margin. This situation is handled by adding the line reset sequence to the printhead initialization procedure, and is repeated between pages of a document.

For each color the PHI keeps a dot usage count for each of the color planes (called AccumDotCount). If a dot is used in particular color plane the corresponding counter is incremented. Each counter is 32 bits wide and saturates if not reset. A write to the DotCountSnap register causes the AccumDotCount[N] values to be transferred to the DotCount[N] registers (where N is 5 to 0, one per color). The AccumDotCount registers are cleared on value transfer.

The DotCount[N] registers can be written to or read from by the CPU at any time. On reset the counters are reset to zero.

The dot counter only counts dots that are passed from the LLU through the PHI to the printhead. Any dots generated by direct CPU control of the PHI pins will not be counted. The PHI interface provides a mechanism for the CPU to directly control the PHI interface pins, allowing the CPU to access the bi-lithic printhead:

- 55 Determine printhead temperature
- Test for and determine dead nozzles for each printhead IC
- Printhead IC initialization
- Printhead pre-heat function

The CPU can gain direct control of the printhead interface connections by setting the PrintHeadCpuCtrl register to one. Once enabled the printhead bits are driven directly by the PrintHeadCpuOut control register, where the values in the register are reflected directly on the printhead pins and the status of the printhead input pins can be read directly from the PrintHeadCpuIn. The direction of pins is controlled by programming PrintHeadCpuDir register.



Silverbrook's bilithic Memjet™ printheads are the target printheads for printing systems which will be controlled by SoPEC and MoPEC devices.

This document presents the format and structure of these printheads, and describes their possible arrangements in the target systems. It also defines a set of terms used to differentiate between the types of printheads and the systems which use them.

The terminology and definitions used to describe the bilithic printhead systems are as follows:

**Printhead Type**—There are 3 parameters which define the type of printhead used in a system:

**Direction of the data flow through the printhead** (clockwise or anti-clockwise, with the printhead shooting ink down onto the page).

**Location of the left-most dot** (upper row or lower row, with respect to  $V_+$ ).

**Printhead footprint** (type A or type B, characterized by the data pin being on the left or the right of  $V_+$ , where  $V_+$  is at the top of the printhead).

**Printhead Arrangement**—Even though there are 8 printhead types, each arrangement has to use a specific pairing of printheads. This gives 4 pairs of printheads. However, because the paper can flow in either direction with respect to the printheads, there are a total of eight possible arrangements, e.g. Arrangement 1 has a Type 0 printhead on the left with respect to the paper flow, and a Type 1 printhead on the right. Arrangement 2 uses the same printhead pair as Arrangement 1, but the paper flows in the opposite direction.

**Color 0** is always the first color plane encountered by the paper.

**Dot 0** is defined as the nozzle which can print a dot in the left-most side of the page.

The Even Plane of a color corresponds to the row of nozzles that prints dot 0.

Note that in all of the relevant drawings, printheads should be interpreted as shooting ink down onto the page.

FIG. 50 shows the 8 different possible printhead types. Type 0 is identical to the Right Printhead presented in FIG. 52, and Type 1 is the same as the Left Printhead. While the printheads shown in FIG. 50 look to be of equal width (having the same number of nozzles) it is important to remember that in a typical system, a pair of unequal sized printheads may be used.

Although the printheads can be physically joined in the manner shown in FIG. 51, it is preferable to provide an arrangement that allows greater spacing between the 2 printheads will be required for two main reasons:

- inaccuracies in the backetch
- cheaper manufacturing cost due to decreasing the tolerance requirements in sealing the ink reservoirs behind the printhead

Failing to account for these inaccuracies and tolerances can lead to misalignment of the nozzle rows both vertically and horizontally, as shown in FIG. 52.

An even row of color  $n$  on printhead A may be vertically misaligned from the even row of color  $n$  on printhead B by some number of dots e.g. in FIG. 52 this is shown to be 5 dots. And there can also be horizontal misalignment, in that the even row of color  $n$  printhead A is not necessarily aligned with

the even row of color  $n+1$  on printhead A, e.g. in FIG. 52 this horizontal misalignment is 6 dots.

The resultant conceptual printhead definition, shown in FIG. 52 has properties that are appropriately parameterized in SoPEC and MoPEC to cater for this class of printheads. The preferred printheads can be characterized by the following features:

All nozzle rows are the same length (although may be horizontally displaced some number of dots even within a color on a single printhead)

The nozzles for color  $n$  printhead A may not be printing on the same line of the page as the nozzles for color  $n$  printhead B. In the example shown in FIG. 52, there is a 5 dot displacement between adjacent rows of the printheads.

The exact shape of the join is an arbitrary shape although is most likely to be sloping (if sloping, it could be sloping either direction)

The maximum slope is 2 dots per row of nozzles

Although shift registers are provided in the printhead at the 2 sides of the joined printhead, they do not drive nozzles—this means the printable area is less than the actual shift registers, as highlighted by FIG. 53.

Table 5 defines the printhead pairing and location of the each printhead type, with respect to the flow of paper, for the 8 possible arrangements

TABLE 5

Printhead Arrangement	Printhead on left side, with respect to the flow of paper	Printhead on right side, with respect to the flow of paper
Arrangement 1	Type 0	Type 1
Arrangement 2	Type 1	Type 0
Arrangement 3	Type 2	Type 3
Arrangement 4	Type 3	Type 2
Arrangement 5	Type 4	Type 5
Arrangement 6	Type 5	Type 4
Arrangement 7	Type 6	Type 7
Arrangement 8	Type 7	Type 6

When using the bilithic printheads, the position of the power/gnd bars coupled with the physical footprint of the printheads mean that we must use a specific pairing of printheads together for printing on the same side of an A4 (or wider) page, e.g. we must always use a Type 0 printhead with a Type 1 printhead etc.

While a given printing system can use any one of the eight possible arrangements of print-heads, this document only presents two of them, Arrangement 1 and Arrangement 2, for purposes of illustration. These two arrangements are discussed below. However, the other 6 possibilities also need to be considered.

The main difference between the two printhead arrangements discussed in this document is the direction of the paper flow. Because of this, the dot data has to be loaded differently in Arrangement 1 compared to Arrangement 2, in order to render the page correctly. FIG. 54 shows an Arrangement 1 printing setup, where the bilithic printheads are arranged as follows:

The Type 0 printhead is on the left with respect to the direction of the paper flow.

The Type 1 printhead is on the right.

Table 6 lists the order in which the dot data needs to be loaded into the above printhead system, to ensure color 0-dot 0 appears on the left side of the printed page.



TABLE 6

Order in which the even and odd dots are loaded for printhead Arrangement 1		
Dot Sense	Type 0 printhead when on the left	Type 1 printhead when on the right
Odd	Loaded second in descending order.	Loaded first in descending order.
Even	Loaded first in ascending order.	Loaded second in ascending order.

FIG. 55 shows how the dot data is demultiplexed within the printheads. FIG. 56 and FIG. 57 show the way in which the dot data needs to be loaded into the printheads in Arrangement 1, to ensure that color 0-dot 0 appears on the left side of the printed page. Note that no data is transferred to the printheads on the first and last edges of SrClk. FIG. 58 shows an Arrangement 2 printing setup, where the bilithic printheads are arranged as follows:

The Type 1 printhead is on the left with respect to the direction of the paper flow.

The Type 0 printhead is on the right.

Table 7 lists the order in which the dot data needs to be loaded into the above printhead system, to ensure color 0-dot 0 appears on the left side of the printed page.

TABLE 7

Order in which the even and odd dots are loaded for printhead Arrangement 2		
Dot Sense	Type 0 printhead when on the right	Type 1 printhead when on the left
Odd	Loaded first in descending order.	Loaded second in descending order.
Even	Loaded second in ascending order.	Loaded first in ascending order.

FIG. 59 shows how the dot data is demultiplexed within the printheads. FIG. 60 and FIG. 61 show the way in which the dot data needs to be loaded into the printheads in Arrangement 2, to ensure that color 0-dot 0 appears on the left side of the printed page. Note that no data is transferred to the printheads on the first and last edges of SrClk. Comparing the signalling diagrams for Arrangement 1 with those shown for Arrangement 2, it can be seen that the color/dot sequence output for a printhead type in Arrangement 1 is the reverse of the sequence for same printhead in Arrangement 2 in terms of the order in which the color plane data is output, as well as whether even or odd data is output first. However, the order within a color plane remains the same, i.e. odd descending, even ascending.

From FIG. 62 and Table 8, it can be seen that the plane which has to be loaded first (i.e. even or odd) depends on the arrangement. Also, the order in which the dots have to be loaded (e.g. even ascending or descending etc.) is dependent on the arrangement. As well as having a mechanism to cope with the shape of the join between the printheads, if the device controlling the printheads can re-order the bits according to the following criteria, then it should be able to operate in all the possible printhead arrangements:

Be able to output the even or odd plane first.

Be able to output even and odd planes in either ascending or descending order, independently.

Be able to reverse the sequence in which the color planes of a single dot are output to the printhead.

TABLE 8

Order in which even and odd dots and planes are loaded into the various printhead arrangements		
Printhead Arrangement	Left side of printed page	Right side of printed page
Arrangement 1	Even ascending loaded first Odd descending loaded second	Odd descending loaded first Even ascending loaded second
Arrangement 2	Odd descending loaded first Even ascending loaded second	Even ascending loaded first Odd descending loaded second
Arrangement 3	Odd ascending loaded first Even descending loaded second	Even descending loaded first Odd ascending loaded second
Arrangement 4	Even descending loaded first Odd ascending loaded second	Odd ascending loaded first Even descending loaded second
Arrangement 5	Odd ascending loaded first Even descending loaded second	Even descending loaded first Odd ascending loaded second
Arrangement 6	Even descending loaded first Odd ascending loaded second	Odd ascending loaded first Even descending loaded second
Arrangement 7	Even ascending loaded first Odd descending loaded second	Odd descending loaded first Even ascending loaded second
Arrangement 8	Odd descending loaded first Even ascending loaded second	Even ascending loaded first Odd descending loaded second



To create a two part printhead, of A4/Letter portrait width to print a page in 2 seconds. Matching Left/Right chips can be of different lengths to make up this length facilitating increased wafer usage the left and right chips are to be imaged on an 8 inch wafer by "Stitching" reticle images.

The memjet nozzles have a horizontal pitch of 32 um, two rows of nozzles are used for a single colour. These rows have a horizontal offset of 16 um. This gives an effective dot pitch of 16 um, or 62.5 dots per mm, or 1587.5 dots per inch, close enough to market as 1600 dpi.

The first nozzle of the right chip should have a 32 um horizontal offset from the final nozzle of the left chip for the same color row. There is no ink nozzle overlap (of the same colour) scheme employed.

VddVpos and Ground supply is made through 30 um wide pads along the length of the chip using conductive adhesive to bus bar beside the chips. Vdd/Vpos is 3.3 Volts. The preferred memjet device requires 180nJ of energy to fire, with a pulse of current for 1 usec. Assuming 95% efficiency, this requires a 55 ohm actuator drawing 57.4 mA during this pulse.

To fire a nozzle, three signals are needed. A dot data, a fire signal, and a profile signal. When all signals are high, the nozzle will fire.

The dot data is provide to the chip through a dot shift register with input Data [x], and clocked into the chip with SrClk. The dot data is multiplex on to the Data signals, as Dot[0-2] on Data[0], and Dot[3-5] on Data[2]. After the dots are shifted into the dot shift register, this data is transfer into the dot latch, with a low pulse in LsyncL. The value in the dot latch forms the dot data used to fire the nozzle. The use of the dot latch allows the next line of data to be loaded into the dot shift register, at the same time the dot pattern in the dot latch is been fired.

Across the top of a column of nozzles, containing 12 nozzles, 2 of each colour (odd and even dots, 4 or 5 lines apart), is two fire register bits and a select register bit. The fire registers forms the fire shift register that runs length of the chip and back again with one register bit in each direction flow.

The select register forms the Select Shift Register that runs the length of the chip. The select register, selects which of the two fire registers is used to enables this column. A '0' in this register selects the forward direction fire register, and a '1' selects the reverse direction fire register. This output of this block provides the fire signal for the column.

The third signal needed, the profile, is provide for all colours with input Pr across the whole colour row at the same time (with a slight propagation delay per column).

The left side print head (chip) and the right side print head that form complete bi-lithic print head, have different nozzle arrangement with respect to the dot order mapping of the dot shift register to the dot position on the page.

FIG. 66 shows the timing of data transfer during normal printing mode. Note SrClk has a default state of high and data is transferred on both edges of SrClk. If there are L nozzles per colour, SrClk would have L+2 edges, where the first and last edges do not transfer data.

Data requires a setup and hold about the both edges of SrClk. Data transfers starts on the first rising after LSyncL rising. SrClk default state is high and needs to return to high after the last data of the line. This means the first edge of SrClk (falling) after LSyncL rising, and the last edge of SrClk as it returns to the default state, no data is transferred to the print head. LSyncL rising requires setup to the first falling SrClk, and must stay high during the entire line data transfer until after last rising SrClk.

The fire shift register controls the rate of nozzle fire. If the register is full of '1's then the you could print the entire print head in a single FrClk cycle, although electrical current limitations will prevent this happening in any reasonable implementation.

Ideally, a '1' is shifted in to the fire shift register, in every  $n^{th}$  position, and a '0' in all other position. In this manner, after n cycles of FrClk, the entire print head will be printed.

The fire shift register and select shift registers allow the generation of a horizontal print line that on close inspection would not have a discontinuity of a "saw tooth" pattern, FIG. 67 a) & b) but a "sharks tooth" pattern of c).

This is done by firing 2 nozzles in every 2n group of nozzle at the same time starting from the outer 2 nozzles working towards the centre two (or the starting from the centre, and working towards the outer two) at the fire rate controlled by FrClk.

To achieve this fire pattern the fire shift register and select shift register need to be set up as show in FIG. 68.

The pattern has shifted a '1' into the fire shift register every  $n^{th}$  positions (where n is usually is a minimum of about 100) and n '1's, followed n '0's in the select shift register. At a start of a print cycle, these patterns need to be aligned as above, with the "1000 . . ." of a forward half of fire shift register, matching an n grouping of '1' or '0's in the select shift register. As well, with the "1000 . . ." of a reverse half of the fire shift register, matching an n grouping of '1' or '0's in the select shift register. And to continue this print pattern across the butt ends of the chips, the select shift register in each should end with a complete block of n '1's (or '0's).

Since the two chips can be of different lengths, initialisation of these patterns is an issue. This is solved by building initialisation circuitry into chips. This circuit is controlled by two registers, nlen(14) and count(14) and b(1). These registers are loaded serially through Data[0], while LSyncL is low, and ReadL is high with FrClk.

The scan order from input is b, n[13-0], c[0-13], color[5-0], mode[2-0] therefore b is shifted in last. The system color and mode registers are unrelated to the Fire Shift Register, but are loaded at the same time as this block.

To make long chips we need to stitch the CMOS (and MEMS) together by overlapping the reticle stepping field. The reticle will contain two areas:

The top edge of Area 2, PAD END contains the pads that stitch on bottom edge of Area 1, CORE. Area 1 contains the core array of nozzle logic. The top edge of Area 1 will stitch to the bottom edge of itself. Finally the bottom edge of Area 2, BUTT END will stitch to the top edge of Area 1. The BUTT END to used to complete a feedback wiring and seal the chip.

The above region will then be exposed across a wafer bottom to top. Area 2, Area 1, Area 1 . . . Area 2. Only the PAD END of Area 2 needs to fit on the wafer. The final exposure of Area 2 only requires the BUTT END on the wafer.

It will be appreciated by those skilled in the art that the foregoing represents only a preferred embodiment of the present invention. Those skilled in the relevant field will immediately appreciate that the invention can be embodied in many other forms.

The invention claimed is:

1. A printing system comprising:
  - a plurality of printhead integrated circuits of different lengths, the printhead integrated circuits being arranged to define a pagewidth printhead having rows of nozzles formed by adjacent nozzle rows of the adjacent printhead integrated circuits, the nozzle rows of the printhead being configured so that there is at least one row for printing each ink color of a plurality of ink colors; and



39

a controller configured to supply print data to the printhead integrated circuits at a rate which is proportional to a ratio of the different lengths of the printhead integrated circuits.

2. A printing system according to claim 1, wherein the controller is configured to supply the print data to the nozzle rows in serial form.

3. A printing system according to claim 2, wherein each of the printhead integrated circuits comprises one or more parallel pairs of the rows, the controller being configured to serially supply the print data to a first of each of the rows in the or each pair of rows, the print data being serially clocked through the first row of the or each pair of rows, then through a second row of the or each pair or rows, until all nozzles have received their respective print data.

4. A printing system according to claim 3, wherein the data is clocked through the second row in a direction substantially opposite to that in which it was clocked through the first row.

40

5. A printing system according to claim 1, comprising a printhead interface in communication with a line loader unit.

6. A printing system according to claim 5, wherein the printhead interface accepts two streams of print data from the line loader unit.

7. A printing system according to claim 6, wherein the line loader unit includes two print data generator units.

8. A printing system according to claim 5, wherein the line loader unit compensates for any vertical misalignment between the printhead integrated circuits.

9. A printing system according to claim 1, wherein the print data is transferred to either the printhead integrated circuits from a memory under the control of the controller.

10. A printing system according to claim 1, wherein the controller is configured to manipulate the supply of print data to each of the printhead integrated circuits such that usage of a memory bandwidth is substantially constant during a print-head loading cycle.

\* \* \* \* \*