



US007714884B2

(12) **United States Patent**  
**Kuribayashi**

(10) **Patent No.:** **US 7,714,884 B2**  
(45) **Date of Patent:** **May 11, 2010**

(54) **OPTICAL MULTI-BEAM SCANNING DEVICE AND IMAGE FORMING APPARATUS**

(75) Inventor: **Yasushi Kuribayashi**, Mishima (JP)

(73) Assignees: **Kabushiki Kaisha Toshiba**, Tokyo (JP);  
**Toshiba Tec Kabushiki Kaisha**, Tokyo (JP)

(\*) Notice: Subject to any disclaimer, the term of this patent is extended or adjusted under 35 U.S.C. 154(b) by 0 days.

(21) Appl. No.: **11/822,782**

(22) Filed: **Jul. 10, 2007**

(65) **Prior Publication Data**  
US 2007/0253050 A1 Nov. 1, 2007

**Related U.S. Application Data**

(63) Continuation of application No. 10/820,750, filed on Apr. 9, 2004, now Pat. No. 7,280,130.

(51) **Int. Cl.**  
**B41J 15/14** (2006.01)  
**B41J 2/47** (2006.01)

(52) **U.S. Cl.** ..... **347/255**; 347/241

(58) **Field of Classification Search** ..... None  
See application file for complete search history.

(56) **References Cited**

**U.S. PATENT DOCUMENTS**

5,739,940 A 4/1998 Kondo  
6,038,353 A 3/2000 Naiki et al.  
6,061,079 A 5/2000 Ota et al.  
6,208,610 B1 3/2001 Kawakami et al.  
6,229,656 B1\* 5/2001 Omura ..... 359/796

6,542,177 B1\* 4/2003 Bronson ..... 347/255  
2001/0033408 A1\* 10/2001 Shiraishi et al. .... 359/212  
2003/0058547 A1 3/2003 Hori et al.  
2003/0138213 A1 7/2003 Jin et al.  
2004/0057109 A1 3/2004 Edney

**FOREIGN PATENT DOCUMENTS**

CN 1195416 A 10/1998  
JP 63-81636 A 4/1988  
JP 5-54421 A 3/1993  
JP 5-303016 A 11/1993  
JP 06-011660 A 1/1994  
JP 6-349100 A 12/1994  
JP 07-234644 A 9/1995  
JP 11194285 A 7/1999  
JP 2003-195209 A 7/2003

**OTHER PUBLICATIONS**

Y. Kuribayashi, U.S. PTO Office Action, U.S. Appl. No. 11/896,677, Jul. 9, 2008, 12 pages.  
Y. Kuribayashi, U.S. Office Action, U.S. Appl. No. 11/896,677, filed Jan. 8, 2009, 13 pgs.

\* cited by examiner

*Primary Examiner*—Matthew Luu  
*Assistant Examiner*—Kendrick X Liu  
(74) *Attorney, Agent, or Firm*—Foley & Lardner LLP

(57) **ABSTRACT**

An optical multi-beam scanning device has a plurality of pre-deflection optical units, an optical path synthesizing member and an excessive light processing member. The excessive light processing member processes excessive light emitted from an excessive light emitting surface with is not an incident surface nor an emitting surface of the optical path synthesizing member. The excessive light processing member has a multi-stage taper constitution with a plurality of taper surfaces having different tilt angles.

**3 Claims, 8 Drawing Sheets**

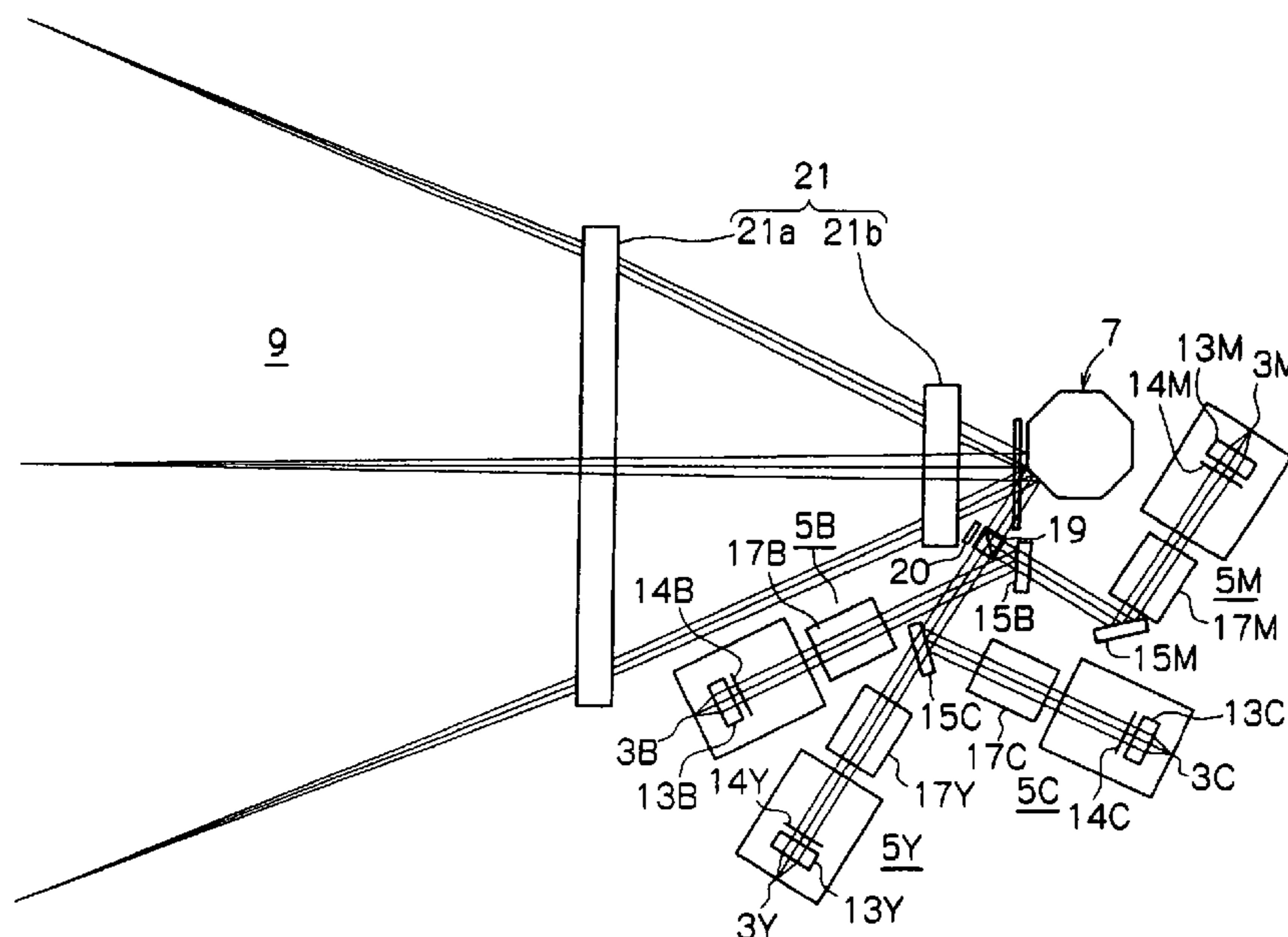

FIG. 1

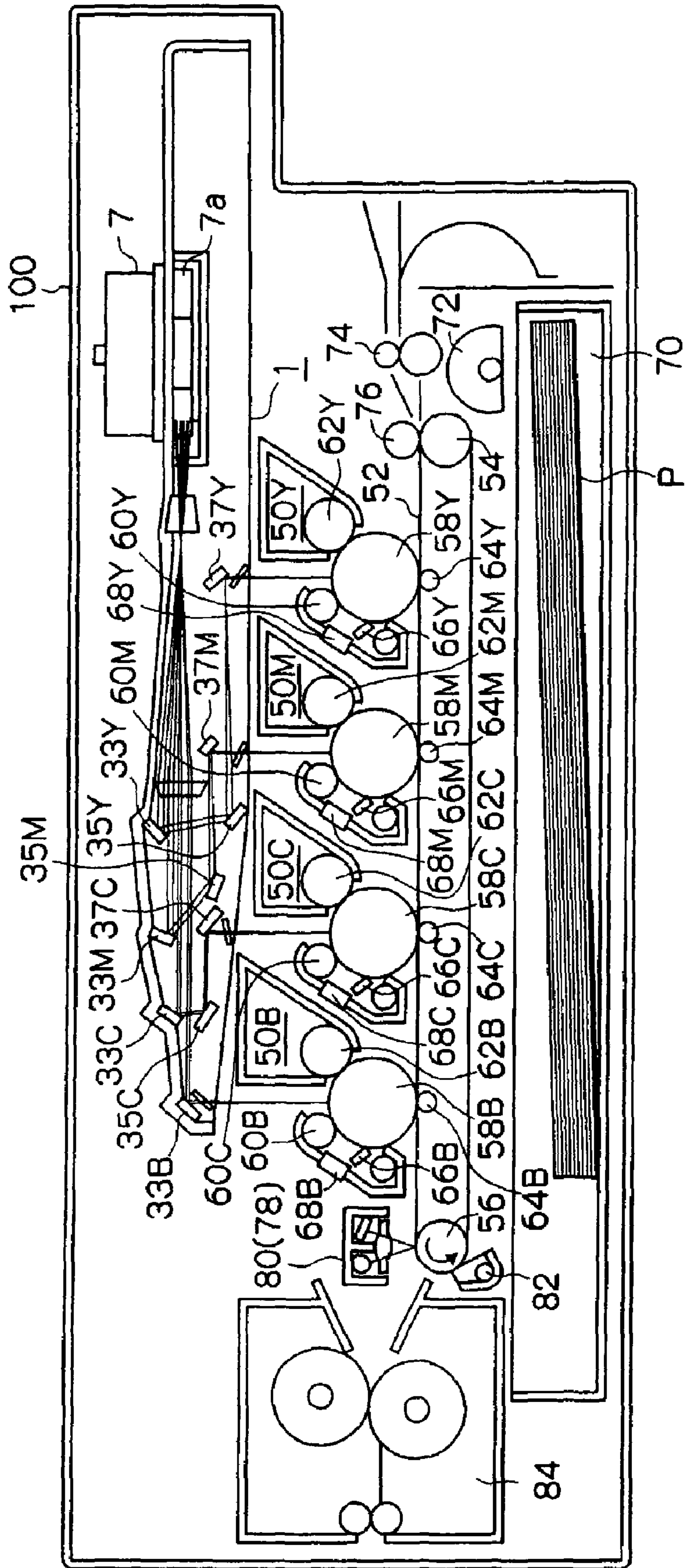

FIG.2

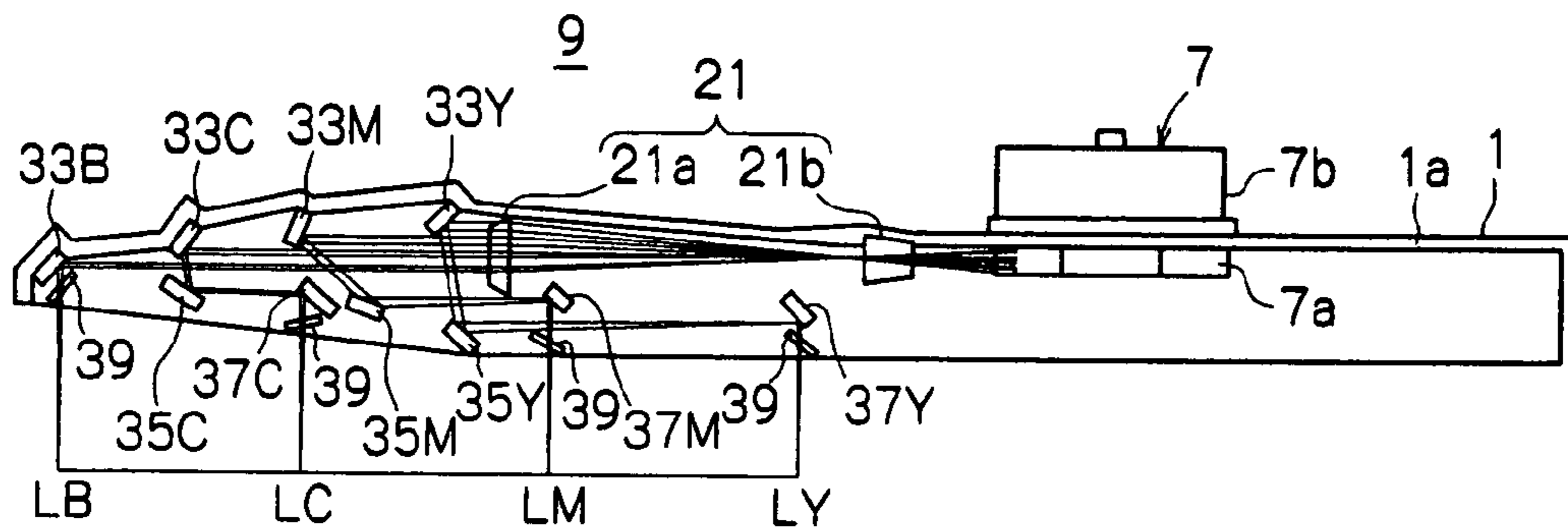

FIG.3

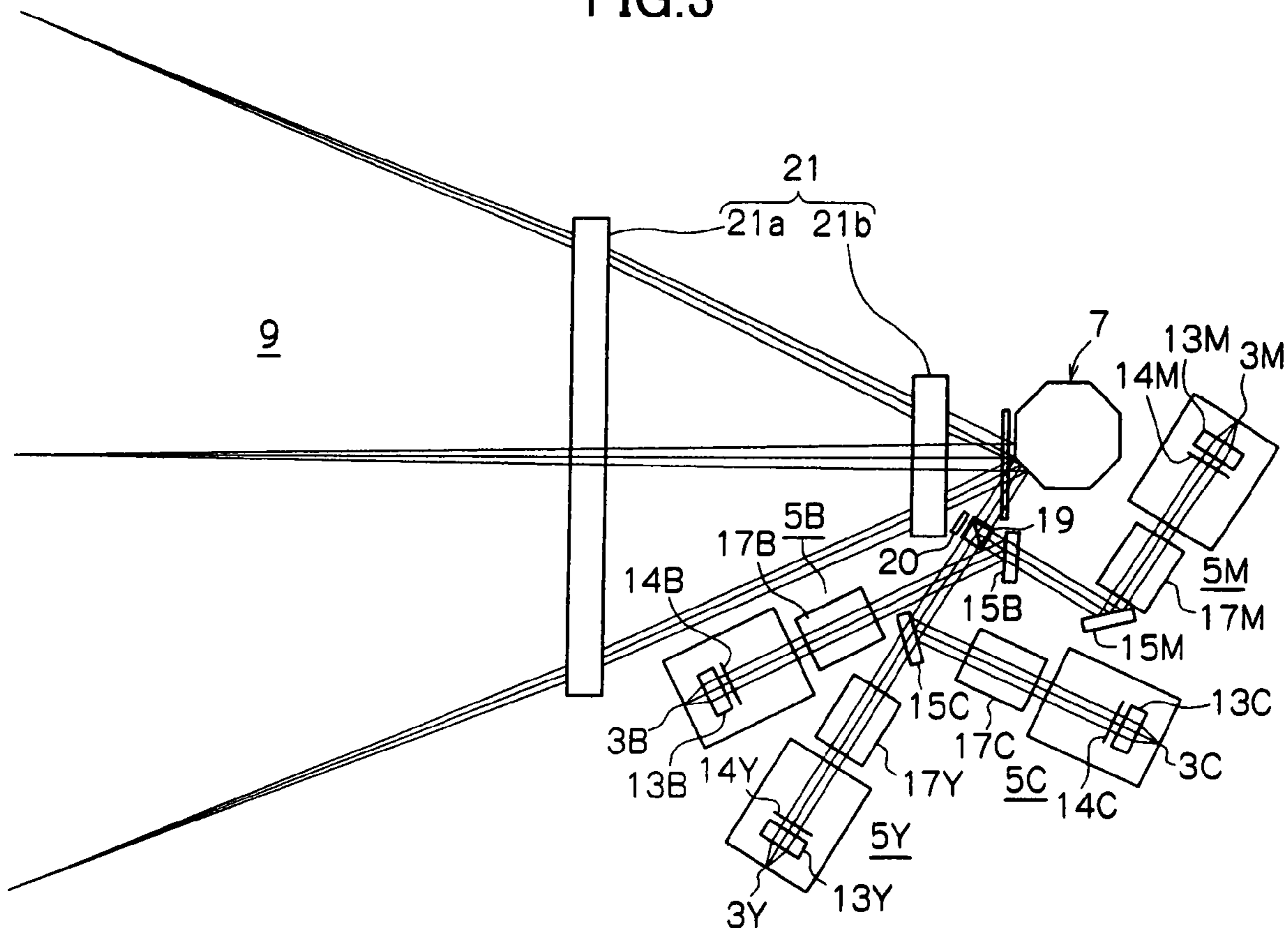

FIG.4

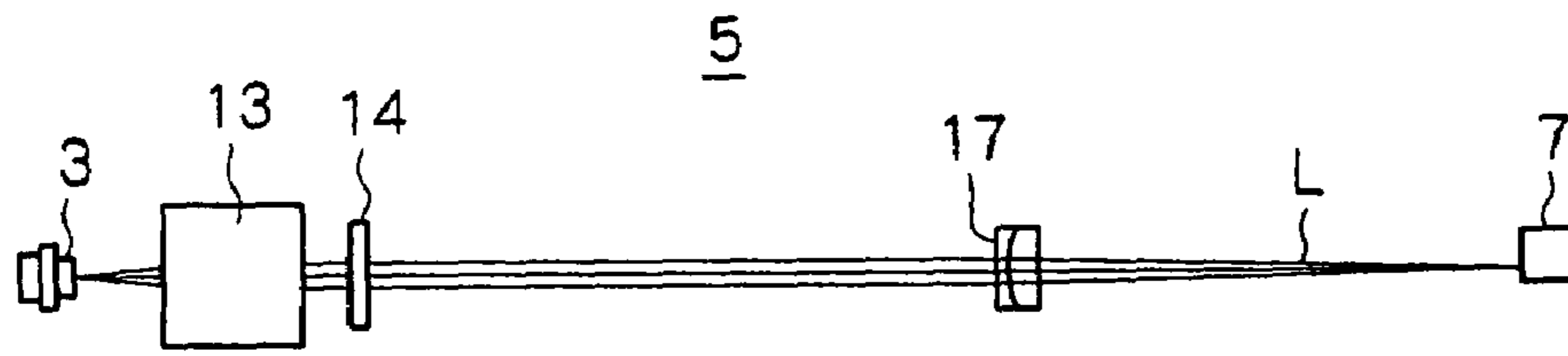

FIG.5A

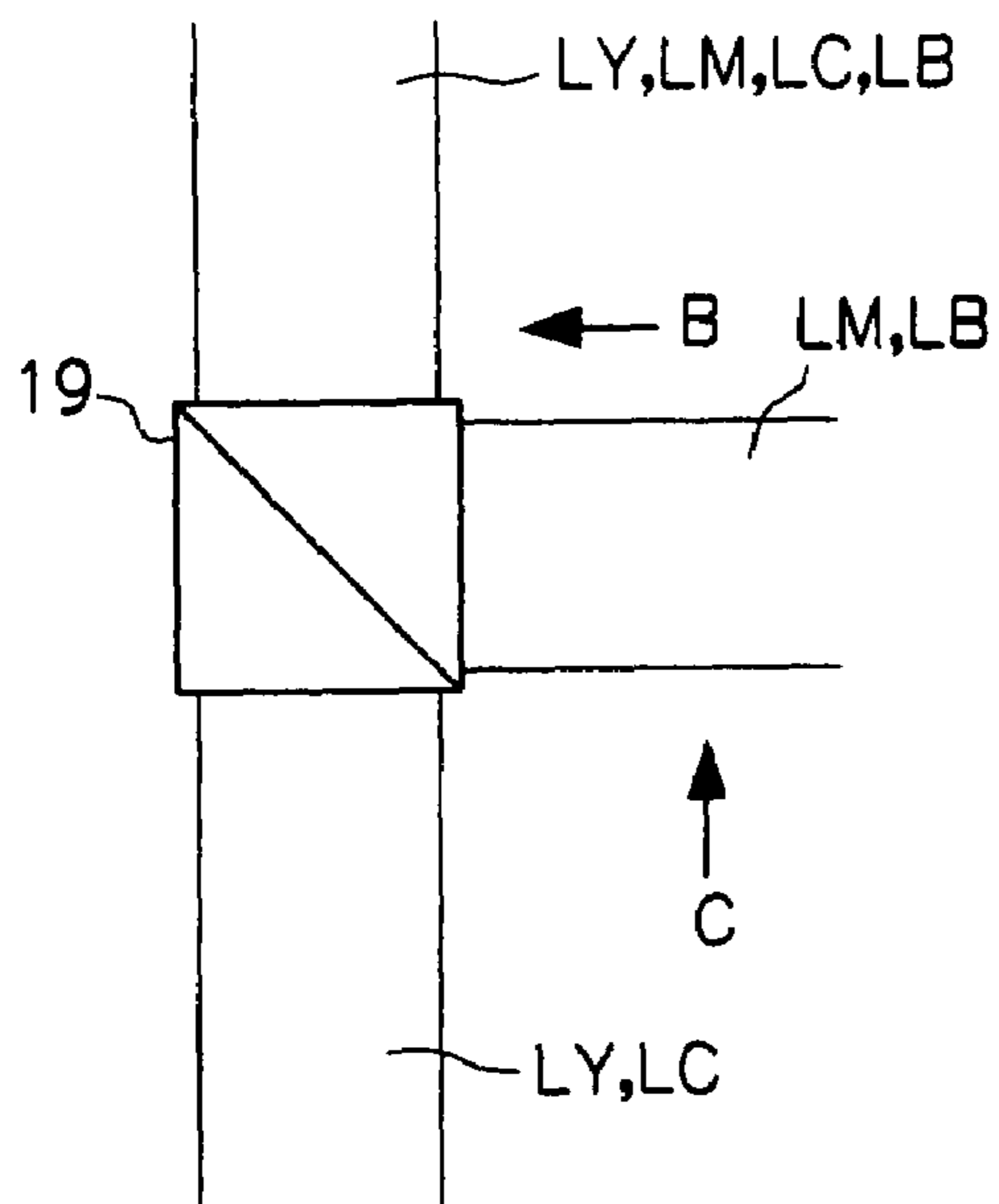

FIG.5B

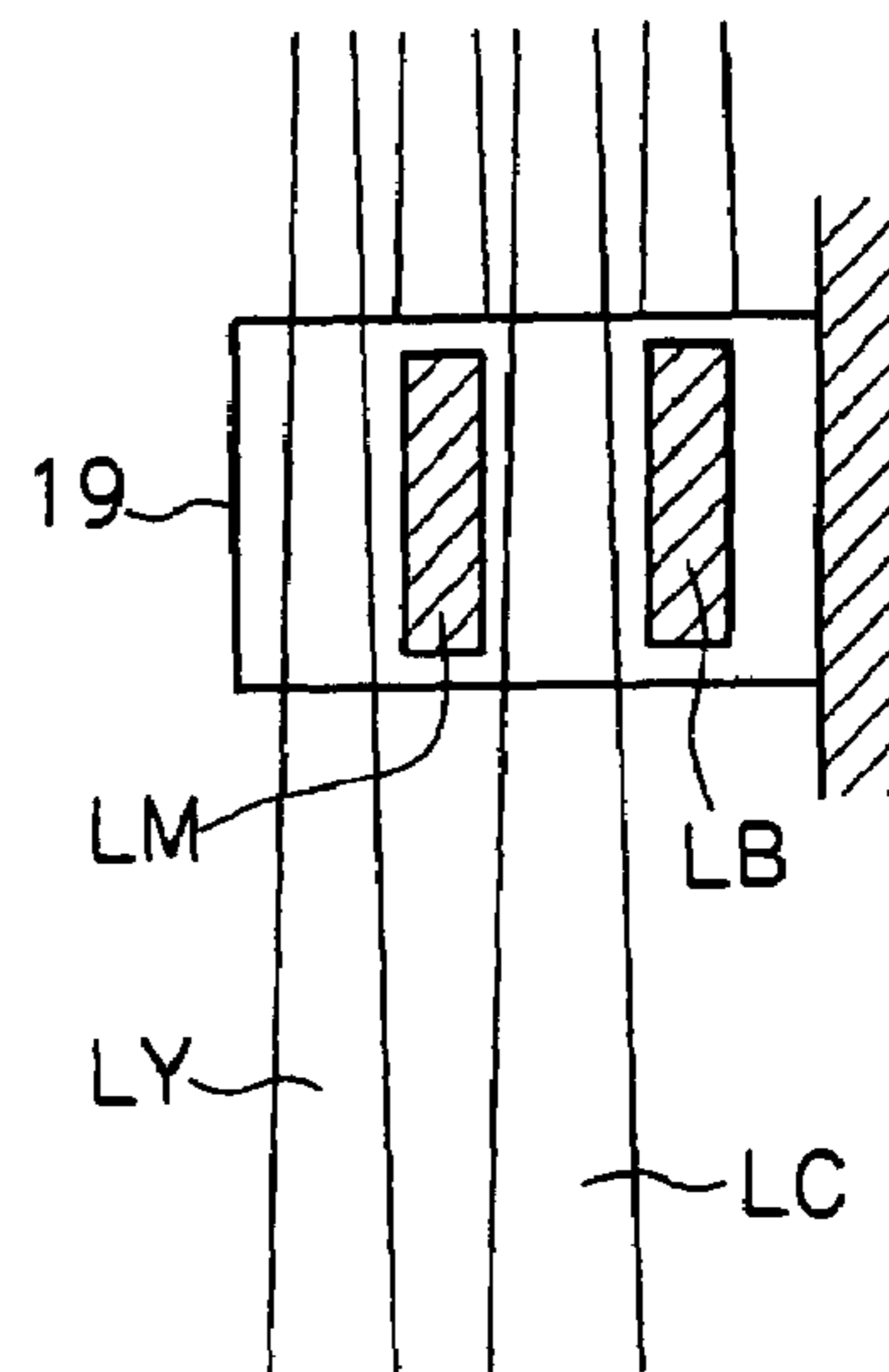

FIG.5C

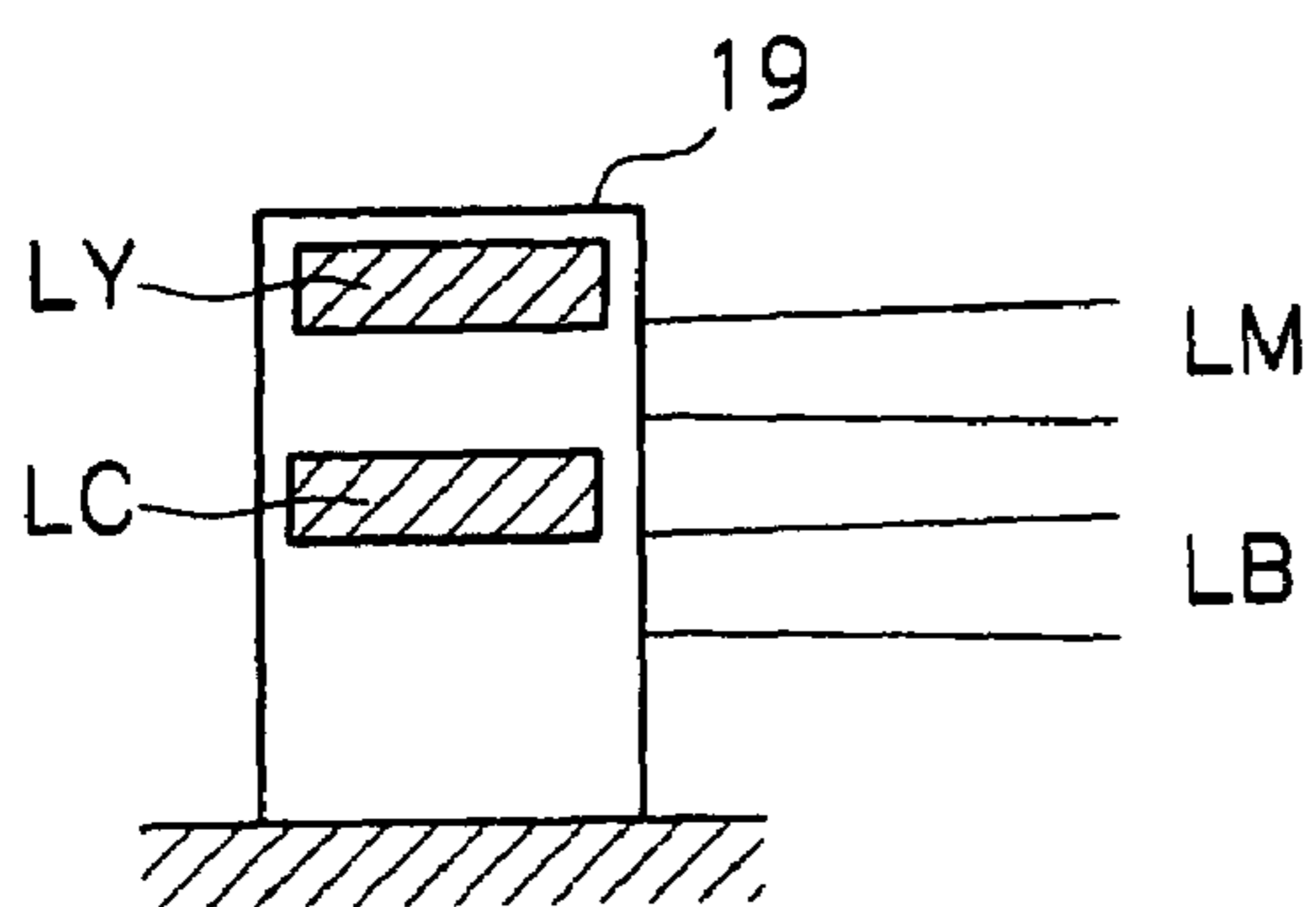

FIG.6

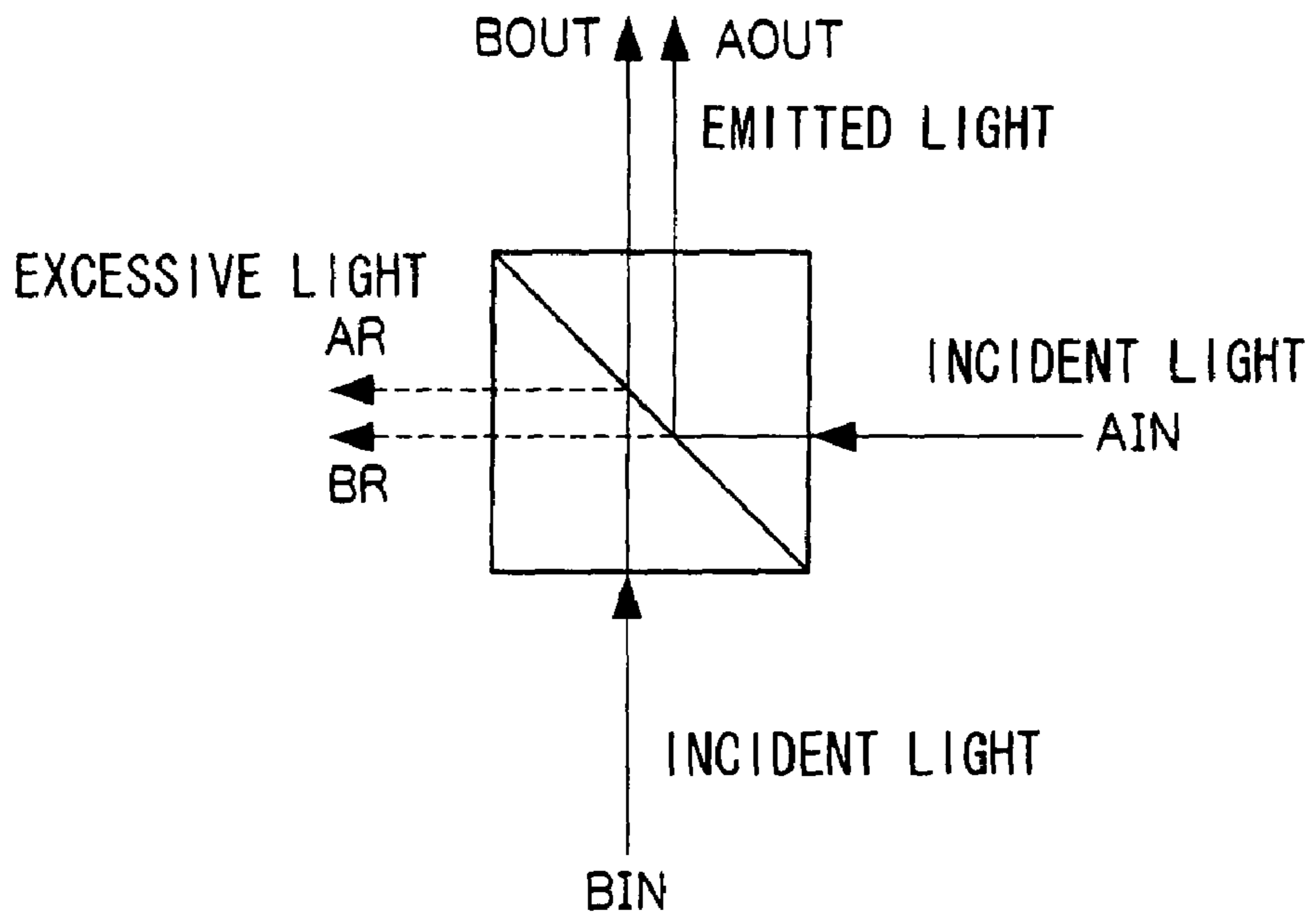

FIG.7

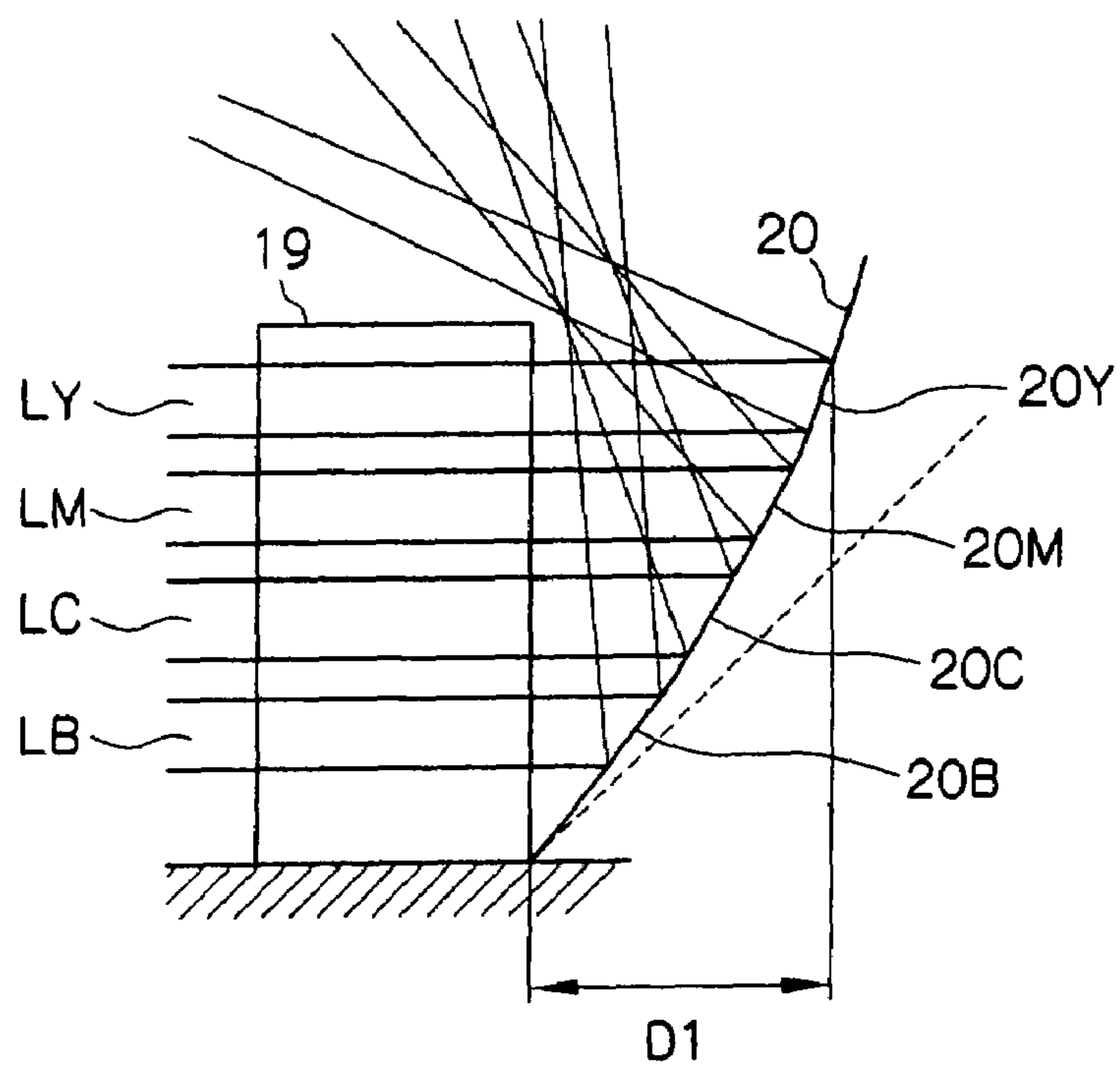

FIG.8

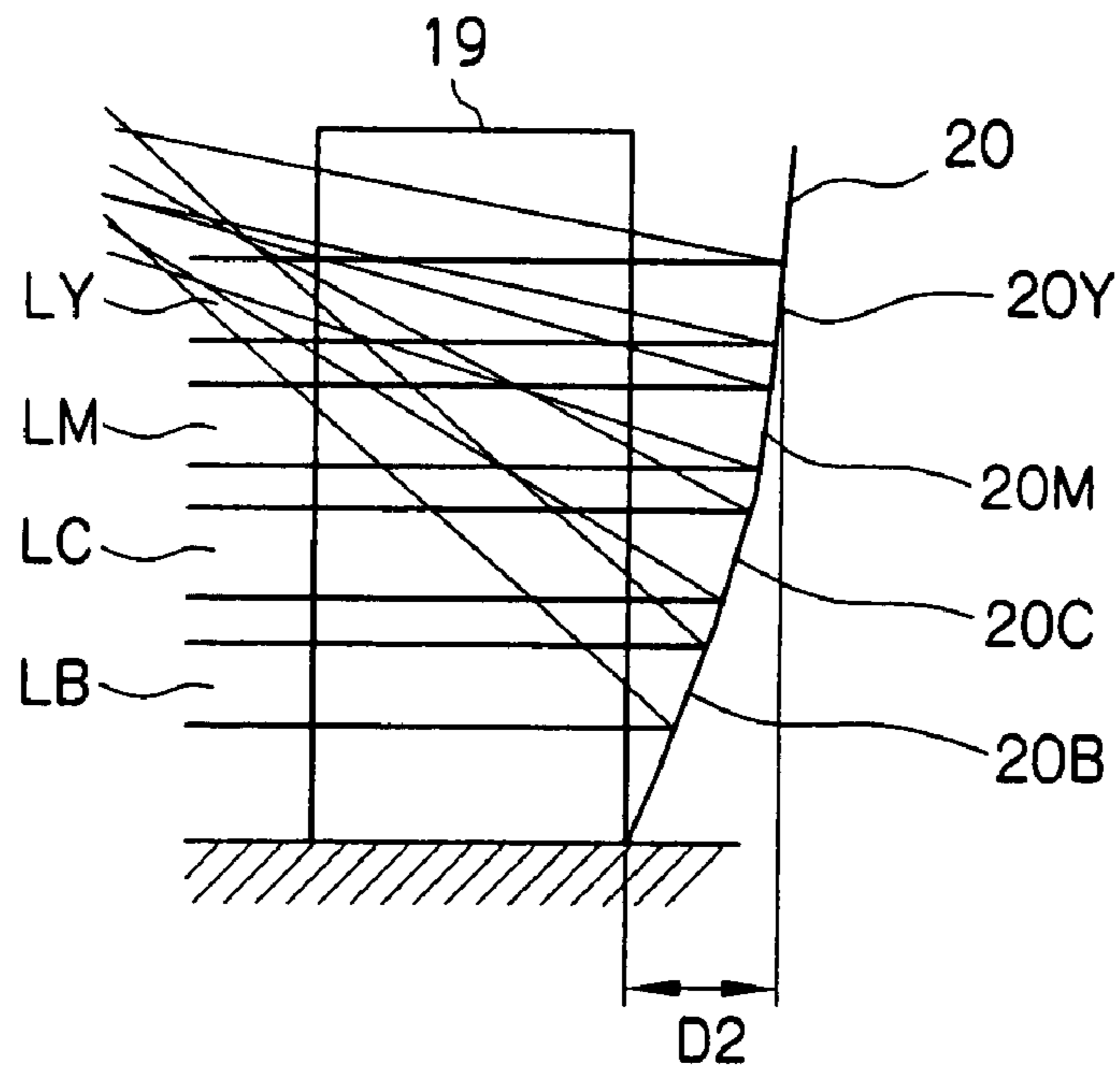

FIG.9

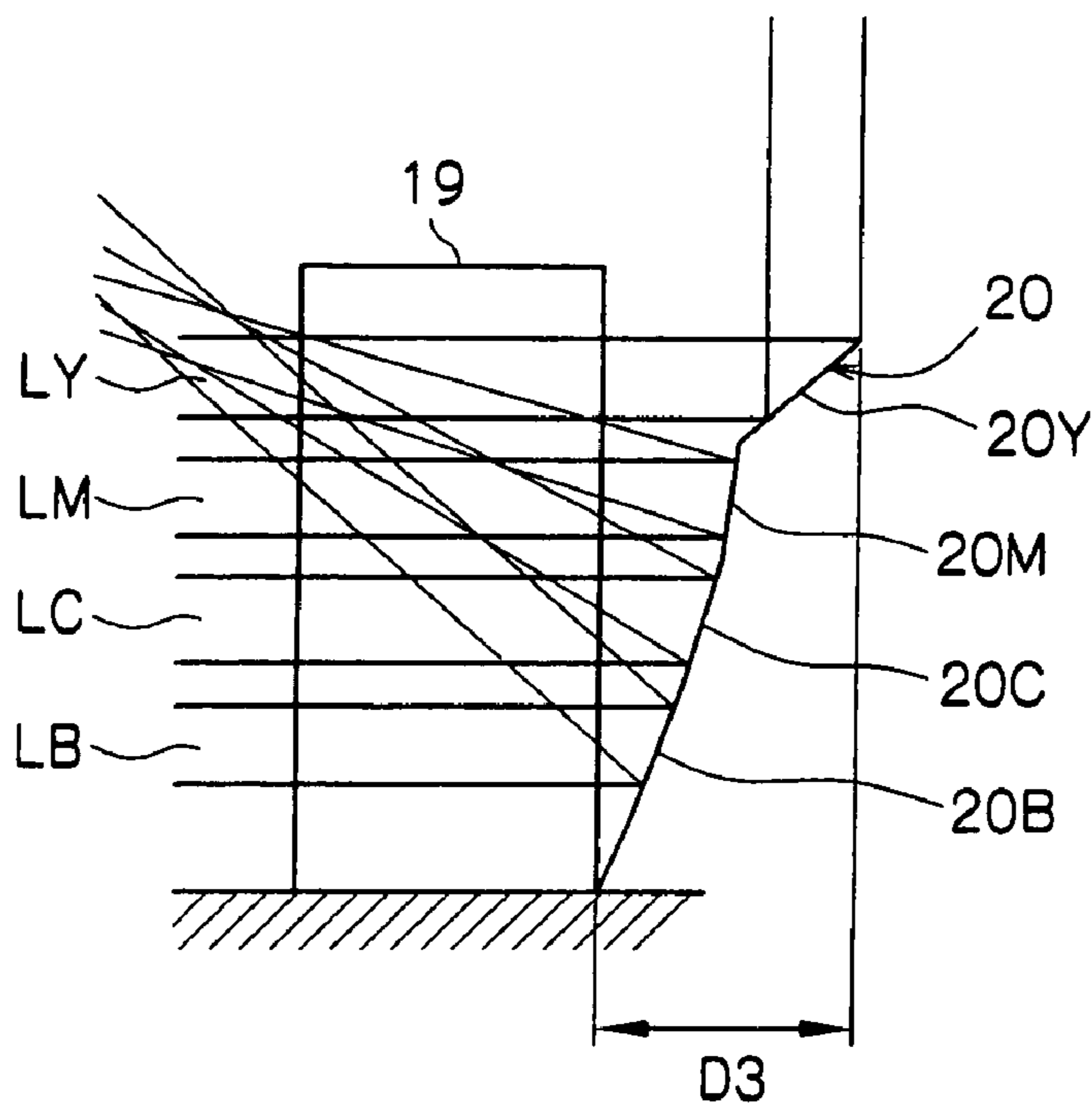

FIG.10A

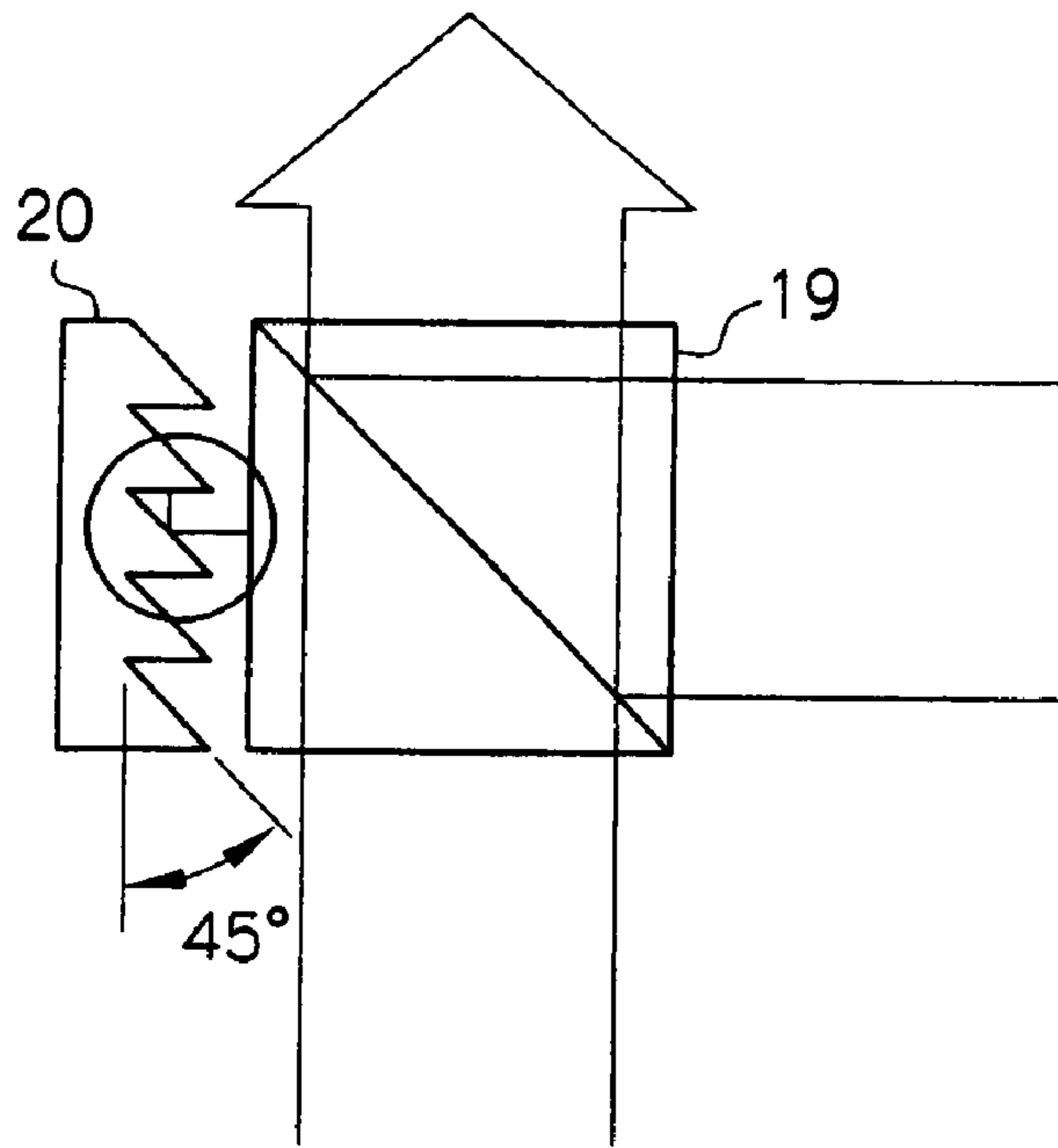

FIG.10B

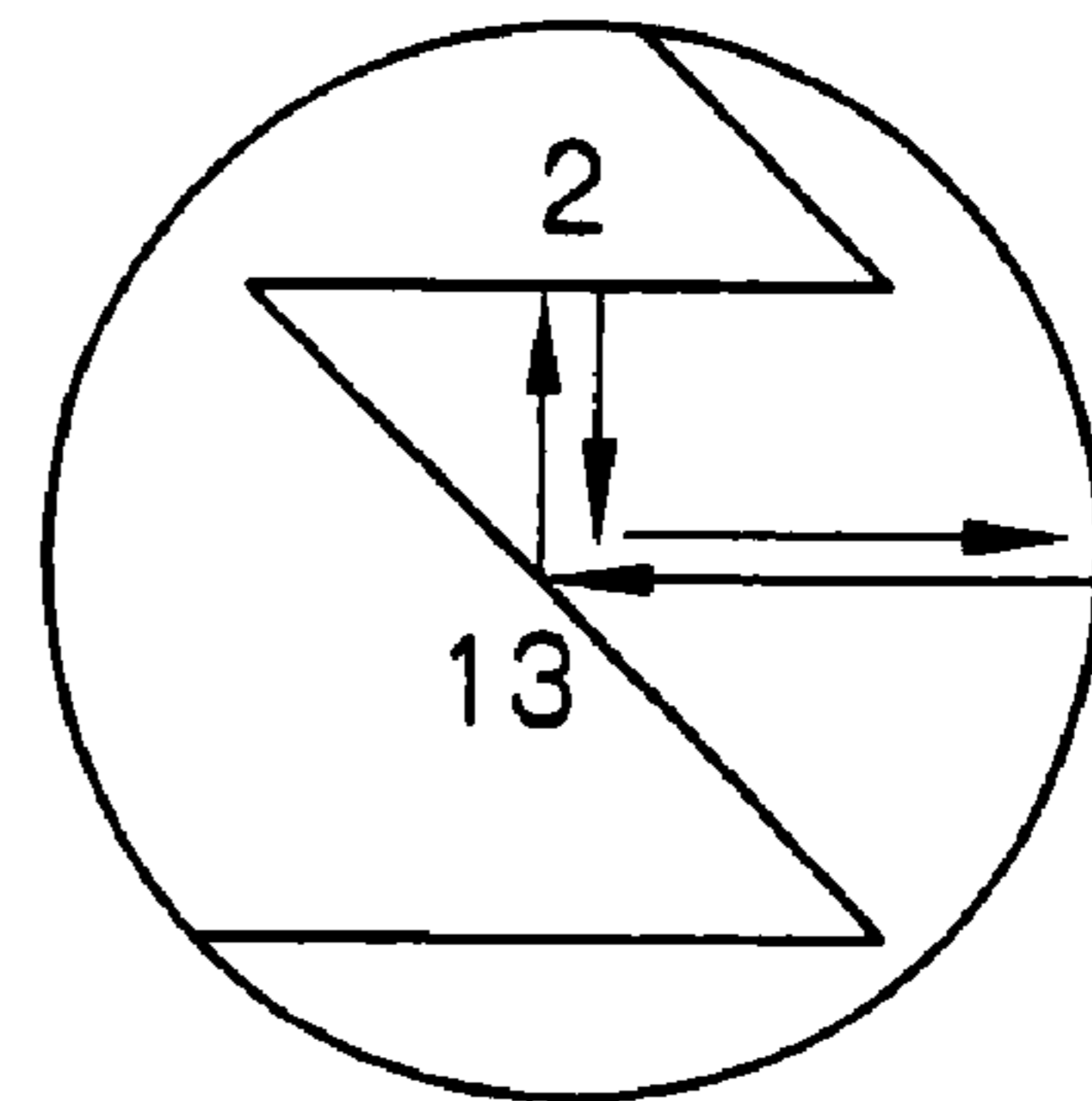

FIG.11A

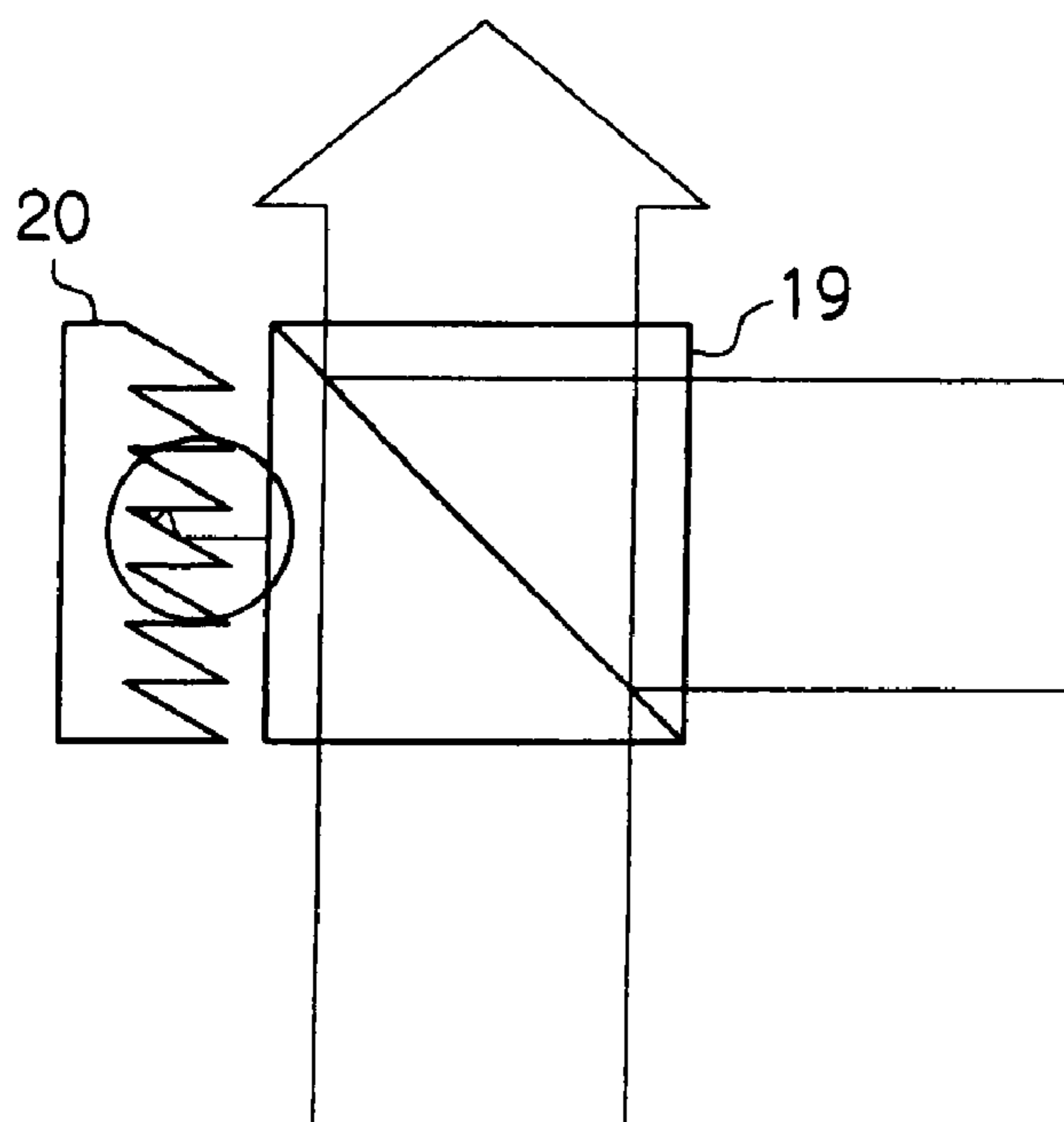

FIG.11B

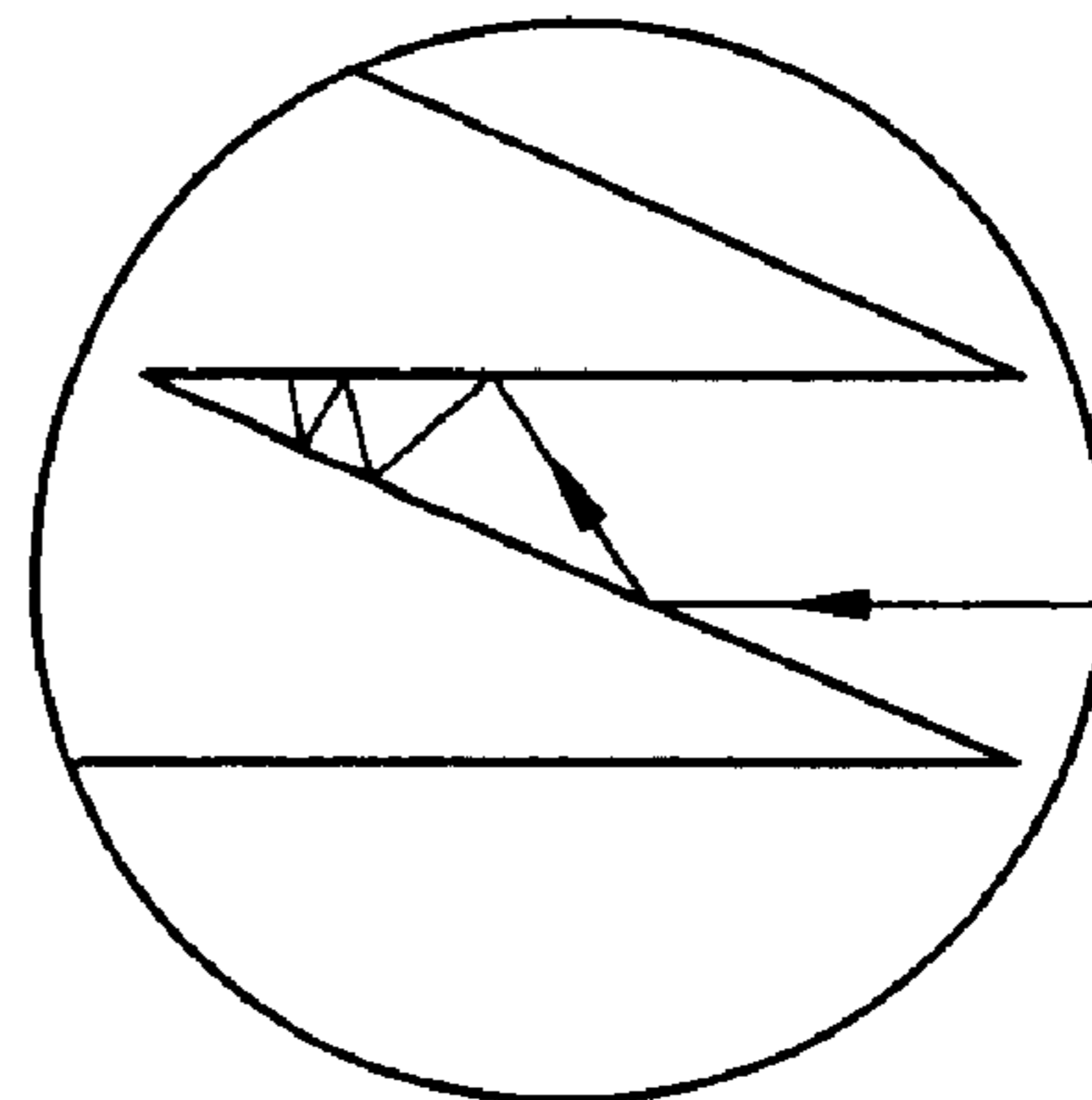

FIG. 12

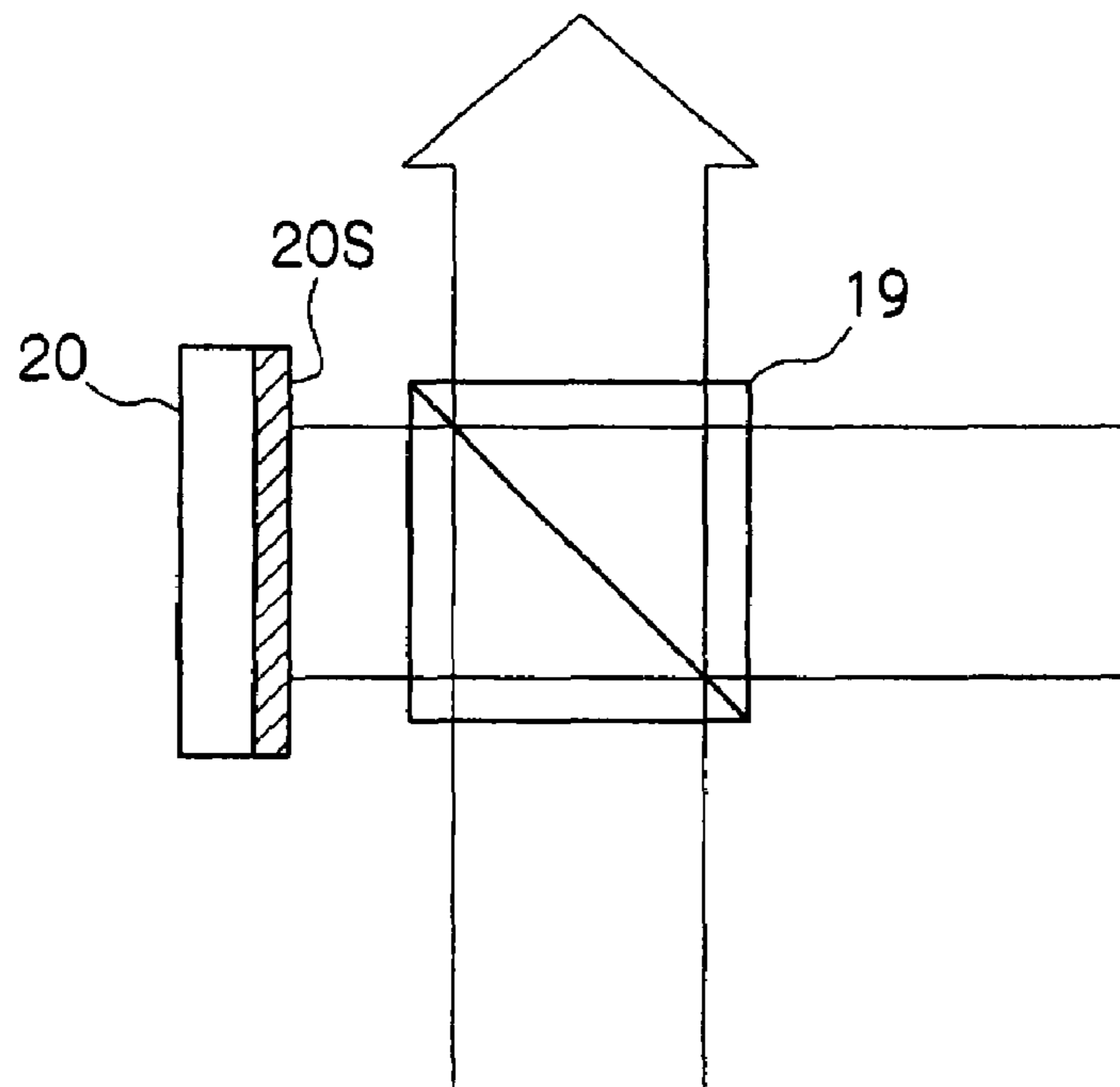

FIG. 13

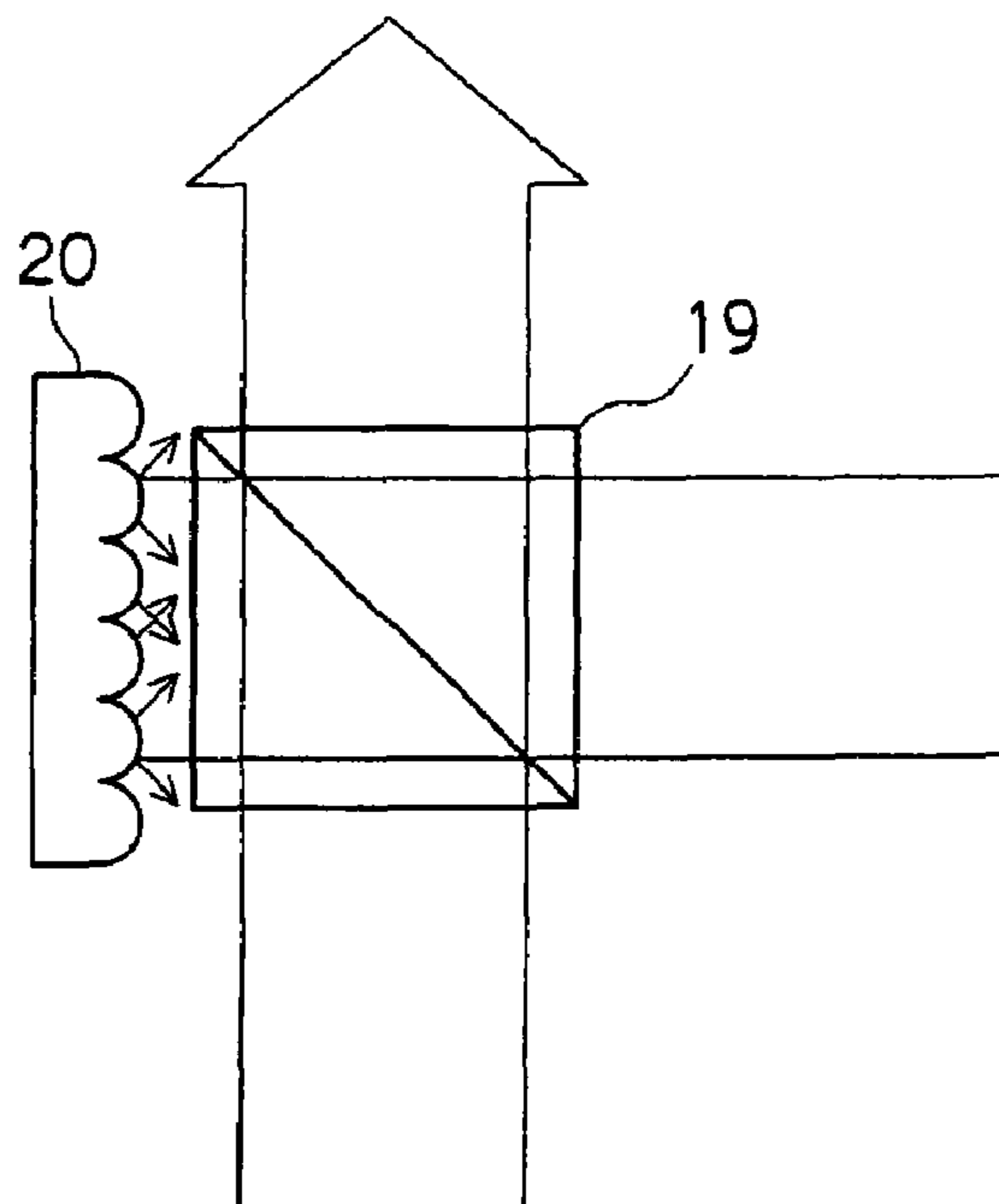



FIG.14

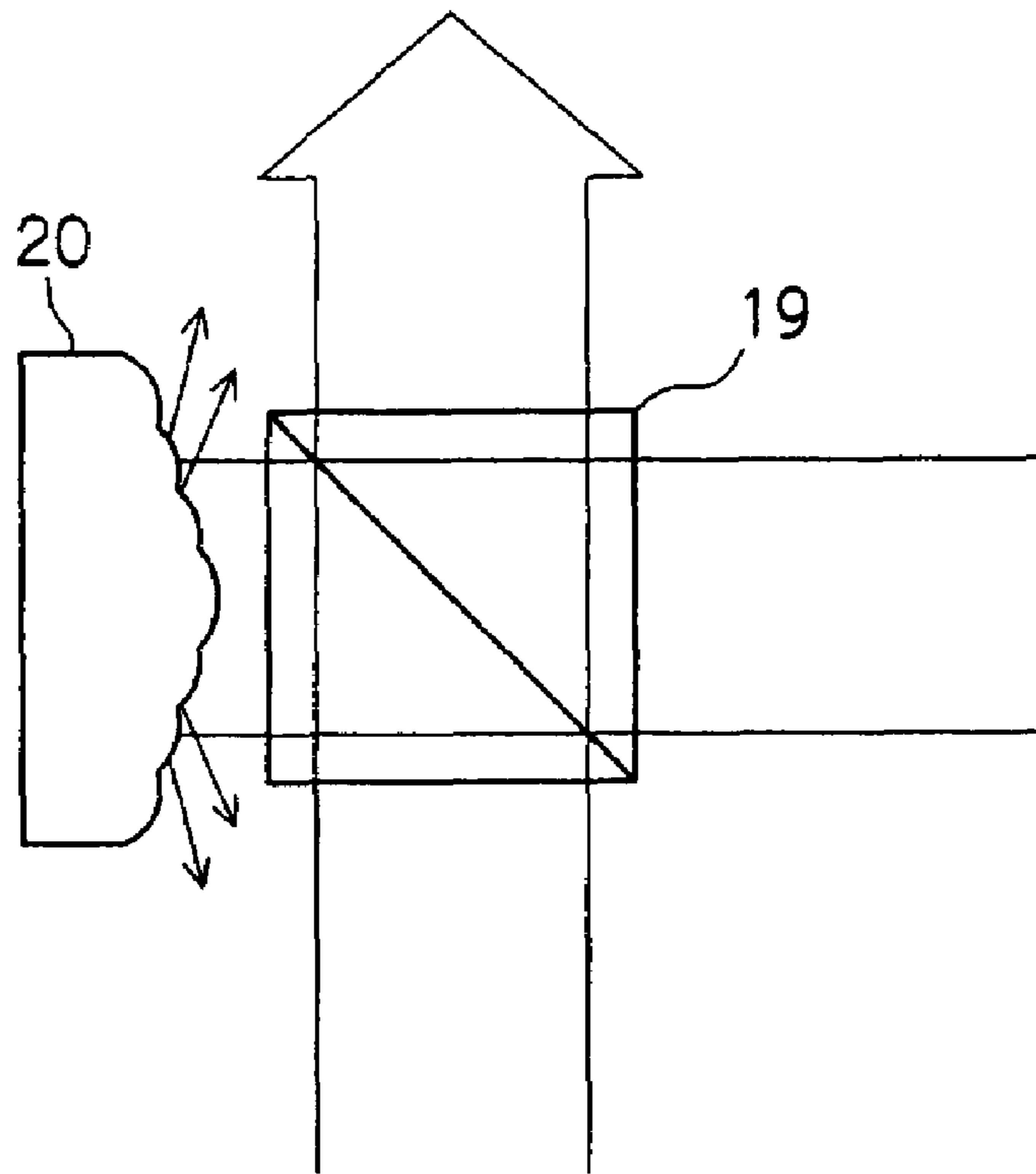
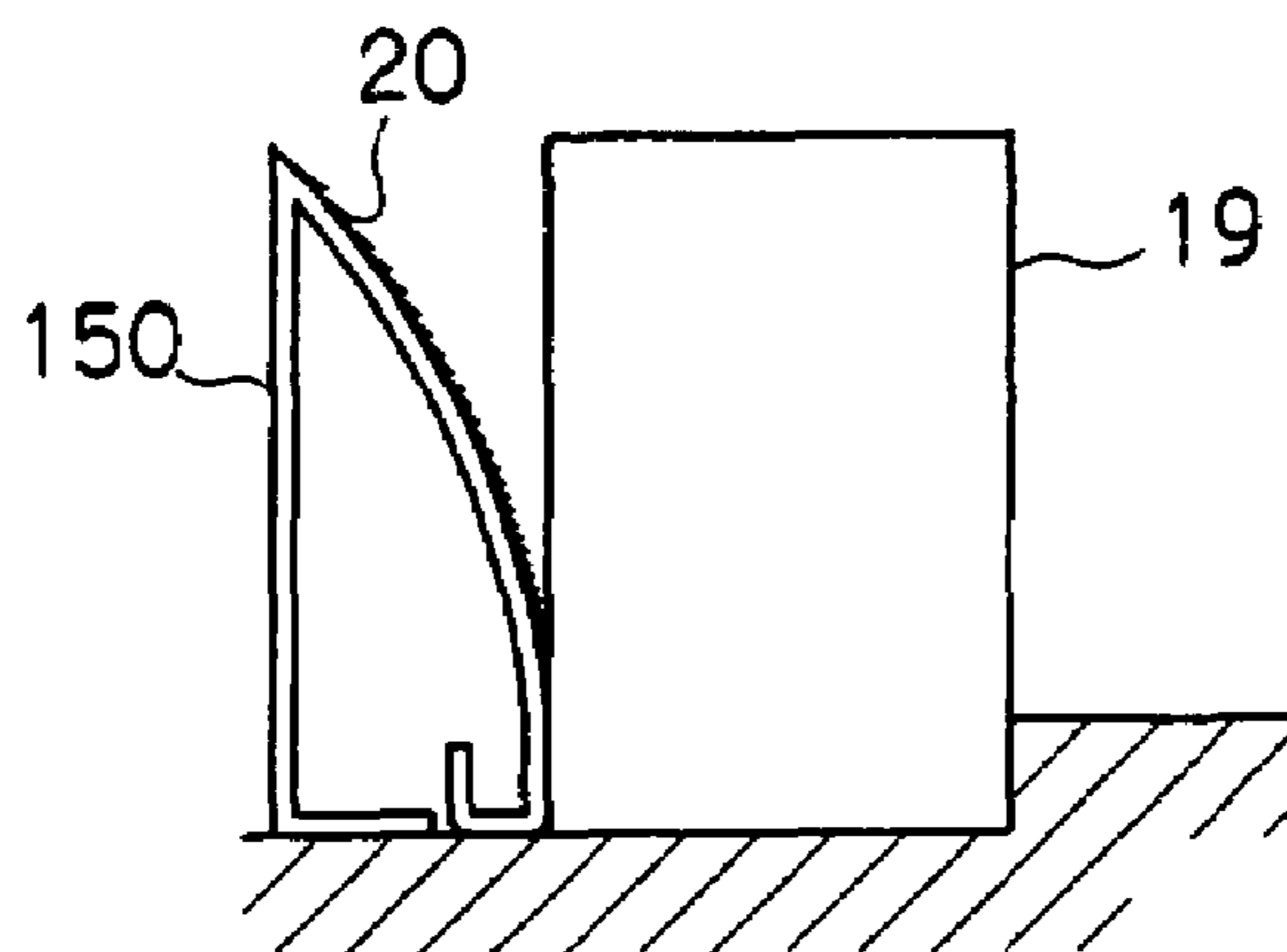

FIG.15



## OPTICAL MULTI-BEAM SCANNING DEVICE AND IMAGE FORMING APPARATUS

### CROSS-REFERENCE TO RELATED APPLICATION

The present application is a continuation based upon U.S. application Ser. No. 10/820,750, filed Apr. 9, 2004, incorporated herein by reference in its entirety.

### BACKGROUND OF THE INVENTION

The invention relates to an image forming apparatus such as a copying machine, a printer, and a composite machine which has a copying function and a printing function, and an optical multi-beam scanning device which is mounted on the image forming apparatus. Specifically, the invention relates to the optical multi-beam scanning device and the image forming apparatus for a color mode.

Image forming apparatuses mainly adopt a method in which a number of light beams to be scanned at a time is increased (multi-beam) as speed heightening means of writing optical systems. In writing optical systems of four-tandem (one pass) color composite machines, it becomes mainstream that a polygon mirror, a scanning lens, and the like are shared in order to reduce the cost.

In the case where the adoption of multi-beam is considered, a method of synthesizing laser beams from individual LDs (laser diodes) with one another using a beam splitter, a half mirror and the like so as to lead the synthesized laser beam to a polygon mirror, and a method of leading a plurality of laser beams to a polygon mirror using an LD array for emitting the laser beams to one direction are considered. From a viewpoint of an installation space, the LD array is advantageous, but when a number of scanning light beams increases to 4, 8, . . . , synthesization using the beam splitter should be used at the same time. In the four-tandem (1 pass) color composite machines, light beams (laser beams) should be separated by a mirror so as to go to photosensitive drums for respective color components after deflection. Since separation intervals are too narrow in the method using the LD array, the method using the individual LDs is preferable.

There are a lot of optical multi-beam scanning devices which adopt the method of synthesizing laser beams from the LDs using the beam splitter, the half mirror, and the like so as to lead the synthesized laser beam to the polygon mirror.

Optical parts for switching a ratio of reflection and transmission by a deflecting direction of a beam from the beam splitter, the half mirror and the like or by the thickness of a reflecting layer, are applied to a synthesizing unit for optical paths of the laser beams. Even in this case, a laser beam (excessive light), which moves to a direction (for example, a reflecting direction) other than an intended direction (for example, a transmitting direction), is also present, and this laser beam becomes stray light and it might deteriorate the performance of the apparatus.

A technique relating to an optical pickup is disclosed in Japanese Unexamined Patent Application Publication No. 5-54421. In this publication, a taper portion of 45° is provided on a portion for housing optical parts of the optical pickup, and excessive light emitted from a polarized light beam splitter is reflected by the taper portion (an optical path of the excessive light is folded by 90°) so as to let it go to the outside. There is also described that if the taper portion is painted black, it is more effective.

Such a stray light countermeasure against the application of the optical parts such as the beam splitter and the half

mirror can be applied only to the case where rear positions of stray light emitting surfaces of the optical parts have a sufficient space. In the optical multi-beam scanning device which leads a plurality of laser beams from a plurality of LDs to one polygon mirror, since installation positions of the respective optical parts are close to one another, the above method cannot be applied in most cases from the viewpoint of the space.

### SUMMARY OF THE INVENTION

It is an object of the present invention to provide an optical multi-beam scanning device which is capable of preventing a bad effect on light sources and other optical parts due to stray light of light beams from an excessive light emitting surface of an optical path synthesizing optical part provided in order to guide a plurality of light beams to one deflecting surface even when a rear position of the excessive light emitting surface does not have a sufficient space, and an image forming apparatus which adopts such an optical multi-beam scanning device.

An optical multi-beam scanning device of the present invention includes: a plurality of light sources; pre-deflection optical units for giving a predetermined property to light beams from the light sources, the pre-deflection optical units corresponding to the light sources, respectively; an optical path synthesizing member for aligning optical paths of the light beams from all or some of the light sources in a horizontal scanning direction after the pre-deflection optical units give the predetermined properties to the light beams or while giving them to the light beams; an excessive light processing member having a multi-stage taper constitution with a plurality of taper surfaces having different tilt angles for reflecting excessive light emitted from an excessive light emitting surface which is not an incident surface nor an emitting surface of the optical path synthesizing member; and a light deflecting device for deflecting the light beams from the pre-deflection optical units corresponding to the light sources to the horizontal scanning direction due to reflection from one surface.

Further, an optical multi-beam scanning device of another aspect of the present invention includes: a plurality of light sources; pre-deflection optical units for giving a predetermined property to light beams from the light sources, the pre-deflection optical units corresponding to the light sources, respectively; an optical path synthesizing member for aligning optical paths of the light beams from all or some of the light sources in a horizontal scanning direction after the pre-deflection optical units give the predetermined properties to the light beams or while giving them to the light beams; an excessive light processing member having an absorbing surface roughly parallel with an excessive light emitting surface for absorbing excessive light emitted from the excessive light emitting surface which is not an incident surface nor an emitting surface of the optical path synthesizing member; and a light deflecting device for deflecting the light beams from the pre-deflection optical units corresponding to the light sources to the horizontal scanning direction due to reflection from one surface.

The absorbing surface of the excessive light processing member is formed by adhering a light absorbing sheet to the absorbing surface, or repeating convexo-concave patterns for reflecting and absorbing the excessive light.

An optical multi-beam scanning device of still another aspect of the present invention includes: a plurality of light sources; pre-deflection optical units for giving a predetermined property to light beams from the light sources, the pre-deflection optical units corresponding to the light

## 3

sources, respectively; an optical path synthesizing member for aligning optical paths of the light beams from all or some of the light sources in a horizontal scanning direction after the pre-deflection optical units give the predetermined properties to the light beams or while giving them to the light beams; an excessive light processing member having repeated local patterns for dispersing excessive light emitted from an excessive light emitting surface which is not an incident surface nor an emitting surface of the optical path synthesizing member; and a light deflecting device for deflecting the light beams from the pre-deflection optical units corresponding to the light sources to the horizontal scanning direction due to reflection from one surface.

An image forming apparatus of the present invention has an optical multi-beam scanning device having a plurality of light sources, a control unit for controlling light emitting timing of the light sources, and photoreceptors on which latent images are formed based on light beams from the optical multi-beam scanning device. The image forming apparatus adopts the above-mentioned optical multi-beam scanning devices as the optical multi-beam scanning device.

## BRIEF DESCRIPTION OF THE DRAWINGS

FIG. 1 is a schematic sectional view illustrating a color image forming apparatus according to a first embodiment of the present invention;

FIG. 2 is a schematic sectional view illustrating components of a post-deflection optical system in an optical multi-beam scanning device according to the first embodiment;

FIG. 3 is a schematic plan view illustrating components of the optical multi-beam scanning device according to the first embodiment;

FIG. 4 is an explanatory diagram illustrating an arrangement of the components of the pre-deflection optical system in the optical multi-beam scanning device according to the first embodiment in which an optical path is a linear optical path;

FIGS. 5A to 5C are diagrams explaining incident light and emitted light to an optical path synthesizing optical part in the optical multi-beam scanning device according to the first embodiment;

FIG. 6 is a diagram explaining excessive light from the optical path synthesizing optical part;

FIG. 7 is a schematic sectional view illustrating an excessive light processing member according to the first embodiment in a vertical scanning direction;

FIG. 8 is a schematic sectional view illustrating the excessive light processing member according to a second embodiment in the vertical scanning direction;

FIG. 9 is a schematic sectional view illustrating the excessive light processing member according to a third embodiment in the vertical scanning direction;

FIGS. 10A and 10B are schematic sectional views illustrating the excessive light processing member according to a fourth embodiment in a horizontal scanning direction;

FIGS. 11A and 11B are schematic sectional views corresponding to FIGS. 10A and 10B illustrating a modified example of the fourth embodiment;

FIG. 12 is a schematic sectional view illustrating the excessive light processing member according to a fifth embodiment in the horizontal scanning direction;

FIG. 13 is a schematic sectional view illustrating the excessive light processing member according to a sixth embodiment in the horizontal scanning direction;

## 4

FIG. 14 is a schematic sectional view in the horizontal scanning direction illustrating a modified example of the sixth embodiment and corresponds to FIG. 13; and

FIG. 15 is a schematic sectional view illustrating the excessive light processing member according to a seventh embodiment in the vertical scanning direction.

## DETAILED DESCRIPTION OF THE INVENTION

An optical multi-beam scanning device and an image forming apparatus according to preferred embodiments of the present invention are explained below with reference to the drawings.

## (A) First Embodiment

FIG. 1 is a diagram illustrating a color image forming apparatus into which the optical multi-beam scanning device according to a first embodiment of the present invention is incorporated. This kind of the color image forming apparatus utilizes four sets of various devices which form four kinds of image data separated into color components of Y (yellow), M (magenta), C (cyan), and B (black) and form images for the respective color components corresponding to Y, M, C and B. For this reason, Y, M, C and B are added to respective reference numerals so that the image data for the respective color components and the devices are discriminated.

As shown in FIG. 1, an image forming apparatus 100 has first to fourth image forming sections 50Y, 50M, 50C and 50B for forming images for color-separated color components.

The image forming sections 50Y, 50M, 50C and 50B are arranged in this order below an optical scanning device 1 correspondingly to positions where laser beams L (Y, M, C and B) are emitted. The laser beams are used for optically scanning image information about the color components using a first folding mirror 33B and third folding mirrors 37Y, 37M and 37C of the optical multi-beam scanning device 1, detailed with reference to FIGS. 2 and 3.

A conveyance belt 52 for conveying a transfer material on which the images formed via the image forming sections 50 (Y, M, C and B) are transferred is arranged below the image forming sections 50 (Y, M, C and B).

The conveyance belt 52 is entrained between a belt driving roller 56 and a tension roller 54 which are rotated to a direction of an arrow by a motor, not shown. The conveyance belt 52 is rotated at a predetermined speed to a direction where the belt driving roller 56 rotates.

The image forming sections 50 (Y, M, C and B) are formed into a cylindrical shape rotatable to a direction of an arrow, and have photosensitive drums 58Y, 58M, 58C and 58B, respectively. Electrostatic latent images corresponding to the images exposed by the optical scanning device 1 are formed on the photosensitive drums.

Charging devices 60 (Y, M, C and B), developing devices 62 (Y, M, C and B), transfer devices 64 (Y, M, C and B), cleaners 66 (Y, M, C and B), and antistatic devices 68 (Y, M, C and B) are arranged in this order, respectively around the photosensitive drums 58 (Y, M, C and B) along the direction where the photosensitive drums 58 (Y, M, C and B) rotate. The charging devices 60 (Y, M, C and B) provide predetermined electric potentials to the surfaces of the photosensitive drums 58 (Y, M, C and B). The developing devices 62 (Y, M, C and B) supply toner having colors corresponding to the electrostatic latent images formed on the surfaces of the photosensitive drums 58 (Y, M, C and B) so as to develop the images. The transfer devices 64 (Y, M, C and B) are arranged so as to be opposed to the photosensitive drums 58 (Y, M, C

## 5

and B) on a rear surface of the conveyance belt **52** with the conveyance belt **52** intervening between the transfer devices and the photosensitive drums. The transfer devices **64** (Y, M, C and B) transfer the toner images on the photosensitive drums **58** (Y, M, C and B) onto a recording medium conveyed by the conveyance belt **52**, namely, recording paper P. The cleaners **66** (Y, M, C and B) eliminate residual toner on the photosensitive drums **58** (Y, M, C and B) which is not transferred when the transfer devices **64** (Y, M, C and B) transfer the toner images onto the paper P. The antistatic devices **68** (Y, M, C and B) remove residual potentials which remain on the photosensitive drums **58** (Y, M, C and B) after the transfer devices **64** (Y, M, C and B) transfer the toner images.

A paper cassette **70** for housing the recording paper P onto which the images formed by the image forming sections **50** (Y, M, C and B) are transferred is arranged below the conveyance belt **52**.

A feeding roller **72** which is primarily formed into a half-moon shape and takes out the paper P housed in the paper cassette **70** one by one starting from the top is arranged on one end of the paper cassette **70** which is close to a tension roller **54**.

A register roller **74** for aligning a forward end of one piece of paper P taken out of the cassette **70** with a forward end of the toner image formed on the photosensitive drum **58B** of the image forming section **50B** (black) is arranged between the feeding roller **72** and the tension roller **54**.

An absorption roller **76** is arranged in a position which is in a vicinity of the tension roller **54** between the register roller **74** and the first image forming section **50Y** and is substantially opposed to an outer periphery of the conveyance belt **52** corresponding to a position where the tension roller **54** contacts with the conveyance belt **52**. The adsorption roller **76** provides a predetermined electrostatic adsorption force to one piece of paper P conveyed at predetermined timing by the register roller **74**.

Registration sensors **78** and **80** are arranged on the outer periphery of the conveyance belt **52** which is at one end of the conveyance belt **52**, and in a vicinity of the belt driving roller **56** and substantially contacts with the belt driving roller **56** with a predetermined distance in an axial direction of the belt driving roller **56** (since FIG. 1 is a front sectional view, the first sensor **78** positioned on a front side of the sheet in FIG. 1 cannot be seen). The registration sensors **78** and **80** detect positions of images formed on the conveyance belt **52** or positions of images transferred onto the paper P.

A conveyance belt cleaner **82** is arranged in a position which is on the outer periphery of the conveyance belt **52** contacting with the belt driving roller **56** and does not contact with the paper P conveyed by the conveyance belt **52**. The conveyance belt cleaner **82** removes toner or slip of paper adhering to the conveyance belt **52**.

A fixing device **84** is arranged in a direction where the paper P conveyed by the conveyance belt **52** is separated from the belt driving roller **56** and is further conveyed. The fixing device **84** fixes the toner images transferred onto the paper P to the paper P.

FIGS. 2 and 3 are diagrams illustrating the optical multi-beam scanning device which is incorporated into the image forming apparatus shown in FIG. 1.

The optical multi-beam scanning device **1** has light sources **3Y**, **3M**, **3C** and **3B**, and a light deflecting device **7** as a deflecting unit. The light sources **3Y**, **3M**, **3C** and **3B** output light beams to the first to fourth image forming sections **50Y**, **50M**, **50C** and **50B** shown in FIG. 1, respectively. The light deflecting device **7** deflects (scans) the light beams (laser beams) emitted from the light sources **3** (Y, M, C and B)

## 6

towards imaging surfaces arranged on predetermined positions, namely, outer peripheral surfaces of the photosensitive drums **58Y**, **58M**, **58C** and **58B** of the first to fourth image forming units **50Y**, **50M**, **50C** and **50B** shown in FIG. 1 at a predetermined linear speed. Predilection optical systems **5** (Y, M, C and B) are arranged between the light deflecting device **7** and the light sources **3** (Y, M, C and B). A post-deflection optical system **9** is arranged between the light deflecting device **7** and the imaging surfaces.

A direction where the light deflecting device **7** deflects (scans) the laser beams is called as a horizontal scanning direction. A direction, which crosses perpendicularly to the horizontal scanning direction and an axial line as a basis of a deflecting operation which is performed on the laser beams by the light deflecting device so that the laser beams scanned (deflected) by the light deflecting device direct to the horizontal scanning direction, is called as a vertical scanning direction.

As shown in FIGS. 3 and 4 (in FIG. 4, arbitrary laser beam L is shown as representative), the pre-deflection optical systems **5** have the light sources (Y, M, C and B) for respective color components composed of semiconductor laser elements, limitary focal lenses **13** (Y, M, C and B), diaphragms **14** (Y, M, C and B), and cylinder lenses **17** (Y, M, C and B), respectively. The limitary focal lenses **13** give predetermined focusing properties to the laser beams emitted from the light sources **3** (Y, M, C and B). The diaphragms **14** (Y, M, C and B) give an arbitrary sectional beam shape to the laser beams L which pass through the limitary focal lenses **13** (Y, M, C and B). The cylinder lenses **17** further give a predetermined focusing property to the laser beams L passing through the diaphragms **14** (Y, M, C and B) in the vertical scanning direction. The pre-deflection optical systems **5** shape the sectional beam shapes of the laser beams emitted from the light sources **3** (Y, M, C and B) into a predetermined shape so as to guide the laser beams to the reflecting surface of the light deflecting device **7**.

After an optical path of the laser beam LC of cyan emitted from the cylinder lens **17C** is folded by a folding mirror **15C**, the laser beam LC transmits an optical path synthesizing optical part **19** so as to be guided to the reflecting surface of the light deflecting device **7**. After an optical path of the laser beam LB of black emitted from the cylinder lens **17B** is folded by a folding mirror **15B**, the laser beam LB is reflected by the optical path synthesizing optical part **19** so as to be guided to the reflecting surface of the light deflecting device **7**. After an optical path of the laser beam LY of yellow emitted from the cylinder lens **17Y** passes through an upper portion of the folding mirror **15C**, the laser beam LY transmits the optical path synthesizing optical part **19** so as to be guided to the reflecting surface of the light deflecting device **7**. After an optical path of the laser beam LM of magenta emitted from the cylinder lens **17M** is folded by a folding mirror **15M** and the laser beam LM passes through an upper portion of the folding mirror **15B**, the laser beam LM is reflected by the optical path synthesizing optical part **19** so as to be guided to the reflecting surface of the light deflecting device **7**. In FIG. 4, the folding mirrors **15Y**, **15B** and **15C** and the optical path synthesizing part **19** are omitted.

FIGS. 5A to 5C are diagrams explaining incident light and emitted light with respect to the optical path synthesizing optical part **19**. FIG. 5A is a plan view, FIG. 5B is a diagram (right side view) in which the optical path synthesizing optical part **19** is viewed from a direction of an arrow B in FIG. 5A, and FIG. 5C is a diagram (front view) in which the optical path synthesizing optical part **19** is viewed from a direction of an arrow C in FIG. 5A.

Heights of positions where the laser beams enter the optical path synthesizing optical part **19** become higher in an order of the laser beam LB of black reflected by the optical path synthesizing optical part **19**, the laser beam LC of cyan transmitting the optical path synthesizing optical part **19**, the laser beam LM of magenta reflected by the optical path synthesizing optical part **19**, and the laser beam LY of yellow transmitting the optical path synthesizing optical part **19**.

An excessive light processing member **20**, mentioned later, which characterizes the first embodiment is provided in a vicinity of the optical path synthesizing optical part **19**.

The light deflecting device **7** has a polygon mirror **7a** whose, for example, eight-plane reflecting surfaces (plane reflecting mirror) are arranged into a regular polygon shape and a motor **7b** for rotating the polygon mirror **7a** at a predetermined speed to the horizontal scanning direction.

The post-deflection optical system **9** has a pair of imaging lenses **21** (**21a** and **21b**), a horizontal synchronization optical sensor **23**, a horizontal synchronization folding mirror **25**, an optical path correcting element **27**, a plurality of mirrors **33Y**, **35Y** and **37Y** (Yellow), **33M**, **35M** and **37M** (magenta), **33C**, **35C**, **37C** (Cyan), and **33B** (black), and the like. The pair of imaging lenses **21** optimize shapes and positions of the laser beams L (Y, M, C and B) deflected (scanned) by the polygon mirror **7a** on the imaging surfaces. The horizontal synchronization optical sensor **23** detects the laser beams L in order to conform the horizontal synchronization of the laser beams L (Y, M, C and B) passing through the pair of imaging lenses **21**. The horizontal synchronization folding mirror **25** folds the laser beams L towards the horizontal synchronization optical sensor **23**. The optical path correcting element **27** is arranged between the folding mirror **25** and the horizontal synchronization optical detector **23**, and makes the laser beams L (Y, M, C and B) for the respective color components reflected towards the horizontal synchronization optical detector **23** by the folding mirror **25** roughly match with the incident position on the detecting surface of the horizontal synchronization optical detector **23**. The mirrors **33Y**, **35Y**, **37Y**, **33M**, **35M**, **37M**, **33C**, **35C**, **37C** and **33B** guide the laser beams L (Y, M, C and B) for the respective color components emitted from the pair of imaging lenses **21** to the corresponding photosensitive drums **58** (Y, M, C and B), respectively.

A beam splitter or a half mirror is adopted as the optical path synthesizing optical part **19**, but when any one of them is used, as shown in FIG. **6**, excessive light is generated. That is to say, incident light AIN (magenta and black) is reflected by the optical path synthesizing optical part (for example, beam splitter) **19** so as to be emitted light AOUT, and a part of the incident light AIN transmits the optical path synthesizing optical part **19** so as to become excessive light AR. Incident light BIN (yellow and cyan) transmits the optical path synthesizing optical part **19** so as to become emitted light BOUT, and a part of the incident light BIN is reflected by the optical path synthesizing optical part **19** so as to become excessive light BR. Both the excessive light AR and BR is emitted from one same surface of the optical path synthesizing optical part **19**.

The excessive light from the optical path synthesizing optical part **19** becomes stray light, and this exerts a bad effect on the light sources and the other optical parts. In order to prevent this situation, the excessive light processing member **20** is provided in a vicinity of the excessive light emitting surface of optical path synthesizing optical part **19**.

FIG. **7** is a schematic sectional view of the excessive light processing member **20** according to the first embodiment in the vertical scanning direction. In FIG. **7**, also the laser beams

for color components reflected in the optical path synthesizing optical part **19** go straight in order to simplify the explanation.

The excessive light processing member **20** according to the first embodiment is provided on a rear side of a surface other than the incident surface and the emitting surface of the optical path synthesizing optical part (beam splitter) **19** (excessive light emitted surface). It is composed of a reflecting wall having a multi-stage taper structure where four taper surfaces **20Y**, **20M**, **20C** and **20B** with different angles are combined.

The taper surface **20B** for processing the excessive light (black) whose emitted position on the optical path synthesizing optical part **19** is the lowest in the vertical scanning direction is set in a position which is the closest to the optical path synthesizing optical part **19**. Further, its tilt angle is set so as to be the smallest. The taper surface **20C** for processing the excessive light (cyan) whose emitted position on the optical path synthesizing optical part **19** is the second lowest in the vertical scanning direction is set in a position which is the second closest to the optical path synthesizing optical part **19**. Further, its tilt angle is set so as to be the second smallest. The taper surface **20M** for processing the excessive light (magenta) whose emitting position on the optical path synthesizing optical part **19** is the second highest is set in a position which is the second farthest from the optical path synthesizing optical part **19**. Further, its tilt angle is set so as to be the second largest. The taper surface **20Y** for processing the excessive light (yellow) whose emitting position on the optical path synthesizing optical part **19** is the highest in the vertical scanning direction is set in a position which is the farthest from the optical path synthesizing optical part **19**. Further, its tilt angle is set so as to be the largest.

As shown in FIG. **7**, the tilt angles of the processing taper surfaces **20Y**, **20M**, **20C** and **20B** are set so that reflected return light from the taper surfaces passes through a position above the optical path synthesizing optical part **19** without crossing it.

A broken line shown in FIG. **7** is drawn in order to compare a taper surface of  $45^\circ$  with the excessive light processing member **20** according to the embodiment. Even the tilt angle of the taper surface **20B** of the excessive light processing member **20** with the smallest angle becomes larger than  $45^\circ$ , and a necessary thickness of the excessive light processing member **20** (a necessary length viewed from a direction where the excessive light travels) is thinner than that of the taper surface of  $45^\circ$ .

According to the optical multi-beam scanning device and the image forming apparatus of the first embodiment, even when a sufficient space is not provided to the rear position on the excessive light emitting surface of the optical path synthesizing optical part for guiding a plurality of light beams to one deflecting surface, the light beams from the excessive light emitting surface is advanced to an unrelated direction by the taper surfaces including the taper surface with steep tilt angle. For this reason, this can prevent the excessive light from becoming stray light and exerting a bad effect on the light sources and the other optical parts.

Since the optical path synthesizing optical part has a multi-stage structure but simply has the taper surface, the taper shape functions as a drawing angle, and thus it can be formed

by injection molding. As a result, the optical path synthesizing optical part can be provided directly on a housing or housing wall of the unit.

#### (B) Second Embodiment

The optical multi-beam scanning device according to a second embodiment of the present invention and the color image forming apparatus according to the second embodiment into which the optical multi-beam scanning device is incorporated have the approximately same constitutions as those in the first embodiment. The constitution of the excessive light processing member **20** provided in the vicinity of the optical path synthesizing optical part **19** is slightly different from that in the first embodiment.

FIG. **8** is a schematic sectional view illustrating the excessive light processing member **20** according to the second embodiment in the vertical scanning direction, and it corresponds to FIG. **7** in the first embodiment.

In the first embodiment, the tilt angles of the processing taper surfaces **20Y**, **20M**, **20C** and **20B** of the excessive light processing member **20** are set so that the reflected return light from the taper surfaces does not cross the optical path synthesizing optical part **19** and passes through a position above it. In the second embodiment, however, the tilt angles of the processing taper surfaces **20Y**, **20M**, **20C** and **20B** of the excessive light processing member **20** are set so that the reflected return light from the taper surfaces passes through the optical path synthesizing optical part **19** but passes through the upper portion of the optical part by the side of the light sources from the optical path synthesizing optical part **19**.

That is to say, in the second embodiment, the tilt angles of the processing taper surfaces **20Y**, **20M**, **20C** and **20B** are larger than those in the first embodiment. As a result, a necessary thickness of the excessive light processing member **20** (a necessary length viewed from the direction where the excessive light advances) **D2** is thinner than the thickness **D1** in the first embodiment.

According to the optical multi-beam scanning device and the image forming apparatus of the second embodiment, the similar effect to that in the first embodiment can be obtained. When the rear position on the excessive light emitting surface of the optical path synthesizing optical part hardly has a sufficient space, the second embodiment is more suitable than the first embodiment.

#### (C) Third Embodiment

In a third embodiment of the present invention, the constitution of the excessive light processing member **20** provided in the vicinity of the optical path synthesizing part **19** is different from those in the first and the second embodiments.

FIG. **9** is a schematic sectional view illustrating the excessive light processing member **20** according to the third embodiment in the vertical scanning direction, and corresponds to FIG. **7** in the first embodiment and FIG. **8** in the second embodiment.

The excessive light processing member **20** according to the third embodiment partially adopts the technical ideas in the first and the second embodiments. That is to say, in the excessive light processing member **20** according to the third embodiment, similarly to the first embodiment, the tilt angle of the taper surface **20Y** for yellow is set so that the reflected return light of the incident excessive light is made to advance above the optical path synthesizing optical part **19** without crossing it. The tilt angles of the other taper surfaces **20M**,

**20C** and **20B** are, however, set so that the reflected return light from the taper surfaces passes through the optical path synthesizing optical part **19** but passes through the upper portion of the optical part by the side of the light sources from the optical path synthesizing optical part **19**.

In the third embodiment, a necessary thickness **D3** of the excessive light processing member **20** (a necessary length viewed from the direction where the excessive light advances) is smaller than the necessary thickness **D1** in the third embodiment. The thickness **D3** is larger than the necessary thickness **D2** in the second embodiment.

Also according to the optical multi-beam scanning device and the image forming apparatus of the third embodiment, the similar effect to that in the first embodiment can be produced. The third embodiment is suitable for the case where the rear position on the excessive light emitting surface of the optical path synthesizing optical part has a space whose size is in the middle between the suitable spaces in the first and second embodiments.

#### (D) Fourth Embodiment

In a fourth embodiment of the present invention, the constitution of the excessive light processing member **20** provided in the vicinity of the optical path synthesizing optical part **19** is different from those in the above embodiments.

FIGS. **10A** and **10B** are schematic sectional views illustrating the excessive light processing member **20** according to the fourth embodiment in the horizontal scanning direction (correspond to the plan view of FIG. **6**).

In the excessive light processing member **20** according to the fourth embodiment, a surface opposed to the excessive light emitting surface of the optical path synthesizing optical part **19** has a sawtooth shape in the cross section in the horizontal scanning direction. The sawtooth shape is composed by repetition of surfaces parallel with the advancing direction of the excessive light and surfaces tilted by 45° to the advancing direction of the excessive light. The excessive light from the optical path synthesizing optical part **19** is reflected three times in the excessive light processing member **20** of the fourth embodiment and is returned to the optical path synthesizing optical part **19** as shown in a partial enlarged diagram of FIG. **10B**.

The excessive light itself from the optical path synthesizing optical part **19** has weak power, and is reflected by the excessive light processing member **20** three times so as to be returned to the optical path synthesizing optical part **19**. For this reason, due to absorption with predetermined absorptance at every time of reflection, the return light to the optical path synthesizing optical part **19** has power which does not exert a bad effect on the light sources and the other optical parts.

Further, the excessive light processing member **20** has the cross section with the sawtooth shape but can be an approximately plate-shaped member, or can be formed as one surface of the housing so as to be capable of being provided very closely to the excessive light emitting surface of the optical path synthesizing optical part **19**.

According to the optical multi-beam scanning device and the image forming apparatus of the fourth embodiment, even when the rear position on the excessive light emitting surface of the optical path synthesizing optical part for guiding a plurality of light beams to one deflecting surface does not have an enough space, the light beams from the excessive light emitting surface are multiply reflected by the excessive light processing member so as to be absorbed at every time of

## 11

reflection. This can prevent the excessive light from becoming stray light and exerting a bad effect on the light sources and the other optical parts.

FIGS. 11A and 11B are diagrams illustrating a modified example of the fourth embodiment, and correspond to FIGS. 10A and 10B. In the excessive light processing member 20 shown in FIGS. 11A and 11B, the sawtooth shape has an acute angle so that a number of reflection times increases for the absorption of the excessive light.

The modified example of the fourth embodiment is such that the repeating direction of the sawtooth shape is not the directions shown in FIGS. 10A, 10B, 11A and 11B. For example, the direction may be the vertical scanning direction.

## (E) Fifth Embodiment

In a fifth embodiment of the present invention, the constitution of the excessive light processing member 20 provided in the vicinity of the optical path synthesizing optical part 19 is different from those in the above embodiments.

FIG. 12 is a schematic sectional view illustrating the excessive light processing member 20 according to the fifth embodiment in the horizontal scanning direction.

The excessive light processing member 20 according to the fifth embodiment is structured as a plate-shaped member so as to have a surface opposed to the excessive light emitting surface of the optical path synthesizing optical part 19. In another manner, the excessive light processing member 20 is structured as one surface of the housing or the like, and a light absorbing sheet 20S is provided to the surface opposed to the excessive light emitting surface of the optical path synthesizing optical part 19.

Also according to the optical multi-beam scanning device and the image forming apparatus according to the fifth embodiment, the light absorbing sheet 20S absorbs the excessive light from the optical path synthesizing optical part. For this reason, the same effect as that in the fourth embodiment can be produced.

## (F) Sixth Embodiment

In a sixth embodiment of the present invention, the constitution of the excessive light processing member 20 provided in the vicinity of the optical path synthesizing optical part 19 is different from those in the above embodiments.

FIG. 13 is a schematic sectional diagram illustrating the excessive light processing member 20 according to the sixth embodiment in the horizontal scanning direction.

The excessive light processing member 20 according to the sixth embodiment is structured as, for example, a plate-shaped member. A plurality of small local reflecting surfaces with a hemispherical shape (or a semicylindrical shape which extends only to a certain direction such as the vertical scanning direction) are arranged on the surface opposed to the excessive light emitting surface of the optical path synthesizing optical part 19, for example, in every direction (for example, the horizontal scanning direction and the vertical scanning direction). The excessive light is reflected from the local reflecting surfaces so as to be dispersed to various directions. As a result, the power of the reflected light per unit area becomes very weak.

The sixth embodiment, therefore, can prevent the excessive light from becoming stray light and exerting a bad effect on the light sources and the other optical parts.

FIG. 14 is a diagram illustrating a modified example of the sixth embodiment, and corresponds to FIG. 13. The excessive light processing member 20 shown in FIG. 14 has a shape

## 12

such that the entire surface including the small local reflecting surfaces with the hemispherical or semicylindrical shape is along a part of the spherical or cylindrical surface. This minimizes an amount of the dispersed light reflected from the local reflecting surfaces which returns to the excessive light emitting surface of the optical path synthesizing optical part 19.

## (G) Seventh Embodiment

In a seventh embodiment of the present invention, the constitution of the excessive light processing member 20 provided in the vicinity of the optical path synthesizing optical part 19 is different from those in the above embodiments.

FIG. 15 is a schematic sectional view illustrating the excessive light processing member 20 according to the seventh embodiment in the vertical scanning direction.

The seventh embodiment can be applied to the case where the optical path synthesizing optical part 19 receives a pressing force of a plate spring member 150 so that its position is regulated by a stopper section 101, and the excessive light emitting surface of the optical path synthesizing optical part 19 receives the pressing force of the plate spring member 150. One surface of the plate spring member 150 opposed to the excessive light emitting surface of the optical path synthesizing optical part 19 has a function of the excessive light processing member 20 according to any one of the embodiments. In an example shown in FIG. 15, one surface of the plate spring member 150 has the function of the excessive light processing member 20 according to the fourth embodiment (specifically, the modified example of the fourth embodiment).

According to the seventh embodiment, new surface finishing or the like is necessary for the plate spring member 150, but the excessive light can be prevented from becoming stray light and exerting a bad effect on the light sources and the other optical parts without providing a new member.

## (H) Another Embodiment

The above embodiments explain various modified examples, but a modified example explained below can be given.

The first to the third embodiments explain that the taper surfaces with different tilt angles whose number is the same as that of the four kinds of the laser beams are provided. The number of the taper surfaces with different angles is not, however, limited to a number of the laser beams as long as their combination can make the thickness of the excessive light processing member 20 thin. The number may be, therefore, two or more. Further, the excessive light processing member 20 may have a curved surface where the tilt angle continuously changes (for example, a surface having a parabola-shaped cross section). In this case, reflection (diffuse reflection) to an unintended direction in a fixed switching position of the tilt angle can be suppressed.

The first to the third embodiments explain that the reflected light from the excessive light processing member 20 directs to a position higher than the incident light viewed from the vertical scanning direction. The tilt angles of the taper surfaces may be selected so that the reflected light from the excessive light processing member 20 directs downward viewed from the vertical scanning direction. In another manner, positive and negative tilt angles are present so that the

light are reflected upward viewed from the vertical scanning direction by a certain taper surface and reflected downward viewed from the vertical scanning direction by another taper surface.

The first to the third embodiments explain that the excessive light is allowed to go upward or downward with respect to the vertical scanning direction, but may be allowed to go to the horizontal scanning direction.

The fourth embodiment explains that the reflection at a plurality of times for absorption of the excessive light is executed by utilizing the sawtooth shape. The reflection at a plurality of times may be executed by utilizing another repeated shape such as a triangular wave shape.

The sixth embodiment explains that the dispersed reflection is executed by the repetition of the local reflecting surfaces with the hemispherical or semicylindrical shape. The dispersed reflection (diffuse reflection) may be executed by rough finishing of the surface and the like.

The above embodiments explain the optical multi-beam scanning device for allowing the four beams to enter one surface of the polygon mirror. The present invention can be, however, applied to optical multi-beam scanning devices for allowing a plurality of beams such as two beams, seven beams or eight beams enter one surface of the polygon mirror. That is to say, the present invention can be applied to optical multi-beam scanning devices having one or more optical path synthesizing optical parts (beam splitter or half mirror) for synthesizing optical paths of beams. Further, the present invention is not limited to the color mode, and can be applied to optical multi-beam scanning devices for monochrome mode having one or more optical path synthesizing parts (beam splitter or half mirror) for synthesizing optical paths of beams.

The position of the pre-deflection optical system in the optical path synthesizing optical part is not limited to the position explained in the embodiments. A cylinder lens for giving a predetermined focusing property in the vertical scanning direction, for example, may be provided on a lower stream side of the optical path synthesizing optical part.

What is claimed is:

1. An optical multi-beam scanning device, comprising:  
a plurality of light sources;

pre-deflection optical units for giving a predetermined property to light beams from the light sources, the pre-deflection optical units corresponding to the light sources, respectively;

an optical path synthesizing member for aligning optical paths of the light beams from all or some of the light sources in a horizontal scanning direction after the pre-deflection optical units give the predetermined properties to the light beams or while giving them to the light beams;

an excessive light processing member having a multi-stage taper constitution with a plurality of taper surfaces having different tilt angles for reflecting excessive light emitted from an excessive light emitting surface which is not an incident surface nor an emitting surface of the optical path synthesizing member, wherein a cross section of the excessive light processing member as seen in a vertical scanning direction is constant along a direction perpendicular to an area of the cross section of the excessive light processing member; and

a light deflecting device for deflecting the light beams from the pre-deflection optical units corresponding to the light sources to the horizontal scanning direction due to reflection from one surface.

2. The optical multi-beam scanning device according to claim 1, wherein the excessive light processing member has the taper surfaces with different angles whose number is the same as that of the optical paths.

3. The optical multi-beam scanning device according to claim 1, wherein the tilt angles of all the taper surfaces in the excessive light processing member are set so that reflected light from the taper surfaces does not enter the excessive light emitting surface of the optical path synthesizing member.

\* \* \* \* \*