



US007676890B2

(12) **United States Patent**
Zhang et al.

(10) **Patent No.:** **US 7,676,890 B2**
(45) **Date of Patent:** **Mar. 16, 2010**

(54) **VIBRATION DAMPENING HANDLE FOR A POWERED APPARATUS**

4,660,832 A 4/1987 Shomo
4,819,742 A 4/1989 Driggers
4,820,090 A * 4/1989 Chen 408/241 R

(75) Inventors: **Qiang J. Zhang**, Baltimore, MD (US);
Daniel H. Sides, Jr., New Freedom, PA (US)

(Continued)

(73) Assignee: **Black and Decker, Inc.**, Newark, DE (US)

FOREIGN PATENT DOCUMENTS

DE 70 24 300.4 10/1970

(*) Notice: Subject to any disclaimer, the term of this patent is extended or adjusted under 35 U.S.C. 154(b) by 326 days.

(Continued)

(21) Appl. No.: **11/258,347**

OTHER PUBLICATIONS

(22) Filed: **Oct. 25, 2005**

Patent Abstracts of Japan Publication No. 11-188663.

(65) **Prior Publication Data**

(Continued)

US 2007/0089274 A1 Apr. 26, 2007

(51) **Int. Cl.**
B25G 1/10 (2006.01)

Primary Examiner—Victor Batson
Assistant Examiner—Jeffrey O'Brien

(52) **U.S. Cl.** **16/431**; 16/436; 16/421;
173/162.2

(57) **ABSTRACT**

(58) **Field of Classification Search** 16/431,
16/436, 421, DIG. 19, DIG. 12, 426; 81/489;
74/551.1, 543; 408/143; 279/7; 173/162.2,
173/162.1

A vibration dampening handle for a powered apparatus includes an elongate gripping member including a first end, a second end opposite the first end, a longitudinal axis extending through the first end and the second end, and a wall defining an inner bore and having an inner surface. The inner bore extends along the longitudinal axis at least partially through the gripping member, and opens on at least the first end of the gripping member. A weighted mass is disposed at the second end of the gripping member. An elongate elastic beam member is one of attached to and integral with the gripping member. The beam member extends along a region of the longitudinal axis and a portion of the beam member is disposed within the inner bore and is spaced apart from the inner surface. The beam member further includes a first end that extends beyond the first end of the gripping member and includes a fastening member adapted to connect the handle to the powered apparatus.

See application file for complete search history.

(56) **References Cited**

U.S. PATENT DOCUMENTS

264,798 A 9/1882 Tyler
1,304,647 A 5/1919 Basta
1,644,630 A 10/1927 Binkele
1,694,559 A 12/1928 Osgood
2,921,326 A * 1/1960 Lautmann 15/145
3,216,052 A 11/1965 Hill
3,581,832 A 6/1971 Heermann et al.
4,401,167 A 8/1983 Sekizawa et al.
4,452,289 A 6/1984 Smith
4,576,241 A 3/1986 Emonet
4,611,671 A * 9/1986 Hansson 173/162.2

29 Claims, 18 Drawing Sheets

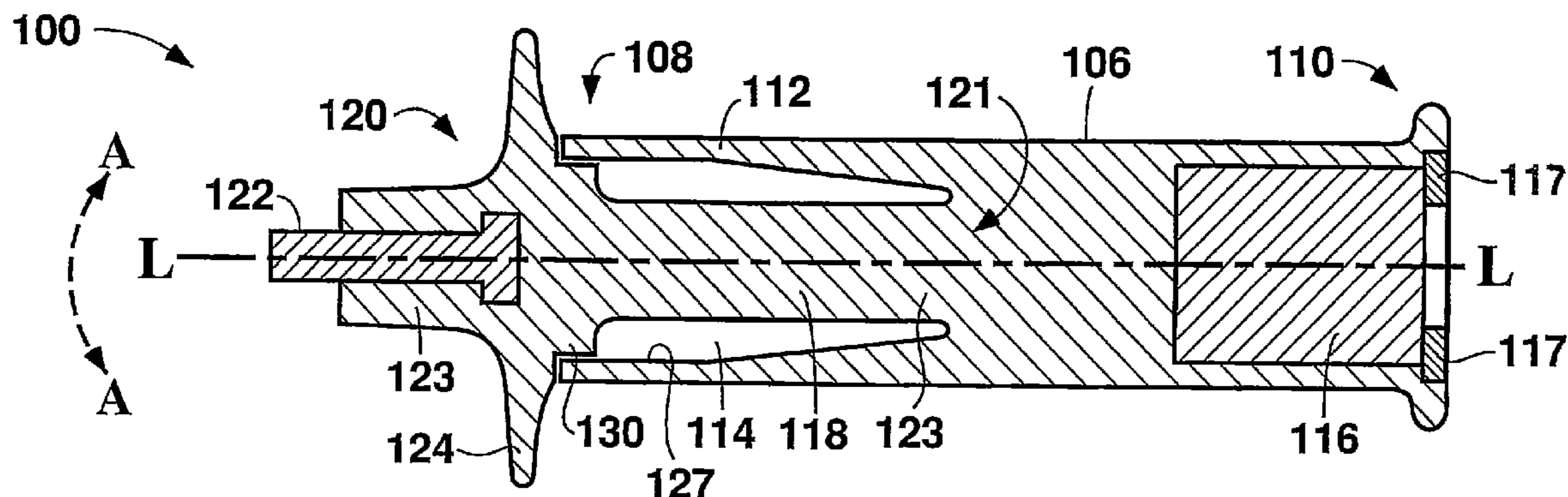

U.S. PATENT DOCUMENTS

4,881,294	A *	11/1989	Riedl	16/426
5,157,807	A *	10/1992	Keller et al.	16/431
5,170,532	A *	12/1992	Holmin et al.	16/431
5,273,120	A *	12/1993	Chang	173/162.2
5,282,938	A	2/1994	Legiec et al.	
5,365,637	A *	11/1994	Bodell et al.	16/431
5,473,939	A	12/1995	Leder et al.	
5,524,884	A	6/1996	Haines	
5,698,241	A	12/1997	Kitzmilller	
5,740,586	A	4/1998	Gomas	
5,769,174	A *	6/1998	Lee et al.	173/162.2
5,769,175	A	6/1998	Matthias	
5,848,453	A *	12/1998	Racodon	16/431
5,933,916	A	8/1999	Loschelder	
6,349,451	B1 *	2/2002	Newman et al.	16/427
6,497,007	B2 *	12/2002	Newman et al.	16/427
6,595,300	B2 *	7/2003	Milbourne	173/170
6,820,523	B1 *	11/2004	Chen	81/177.2
6,968,599	B2 *	11/2005	Blauer et al.	16/431
2004/0016082	A1	1/2004	Yi	
2004/0108213	A1	6/2004	Talasek et al.	
2005/0087353	A1	4/2005	Oki et al.	

FOREIGN PATENT DOCUMENTS

DE	2804223	A1	8/1979
DE	33 04 849	C2	11/1983
DE	86 07 169.6		3/1986
DE	87 07 353.6		9/1987
DE	9004091	U1	6/1990
DE	100 55 395	A1	5/2002
DE	101 26 491	A1	12/2002

EP	0164324	A2	12/1985
EP	0 156 387	B1	11/1990
EP	0 490 850	B1	10/1995
EP	0 689 902	A1	1/1996
EP	0849492	A2	6/1998
EP	0 995 553	A2	4/2000
EP	0 680 399	B1	11/2000
EP	1 358 968	A1	11/2003
EP	1 514 648	A1	3/2005
EP	1882560	A2 *	1/2008
GB	2 080 919		2/1982
GB	2080919	A *	2/1982
GB	2086005	A *	5/1982
JP	56-45386		4/1981
JP	58-137571		8/1983
JP	59-47171		3/1984
JP	05-86482		8/1992
JP	61-81889		7/1994
JP	09-254054		9/1997
JP	11-188663		7/1999
JP	2004-249430	A2	9/2004
WO	WO 01/64401	A1	9/2001

OTHER PUBLICATIONS

Patent Abstracts of Japan Publication No. 09-254054.
 Patent Abstracts of Japan Publication No. 2004-249430.
 Patent Abstracts of Japan Publication No. 01214401 A.
 English Language Patent Abstract for Japanese Patent Publication
 No. JP401214401A.
 European Search Report, Application No. 06122598.3, dated Mar.
 16, 2007, 11 pages.

* cited by examiner

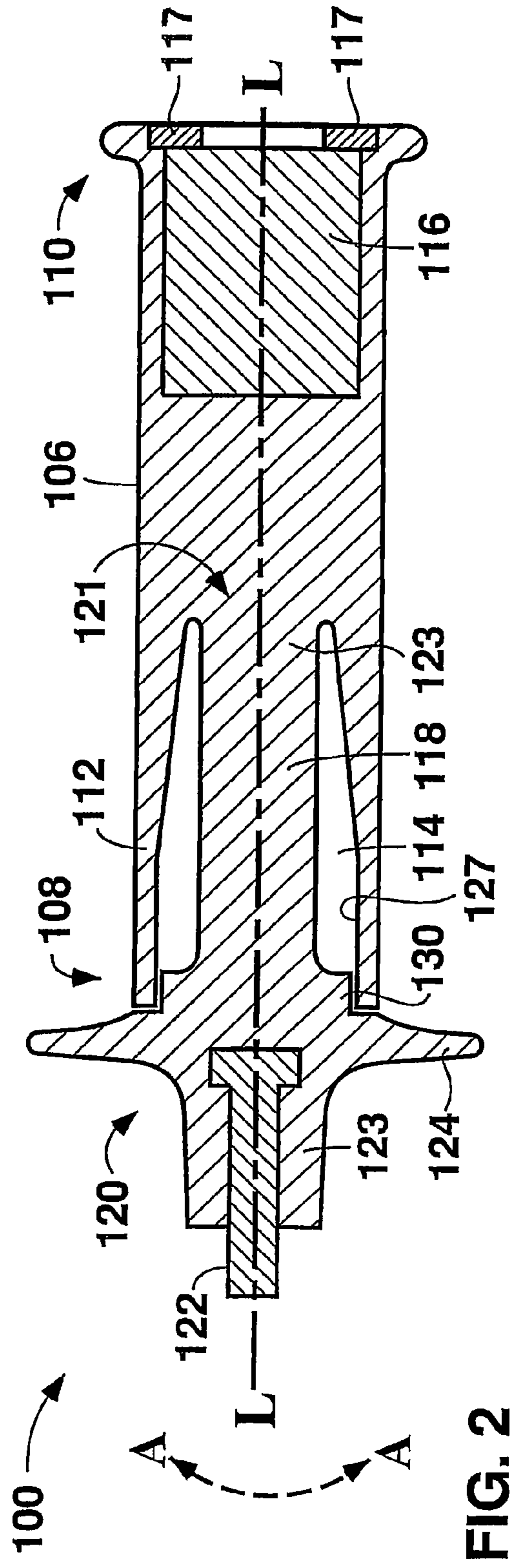
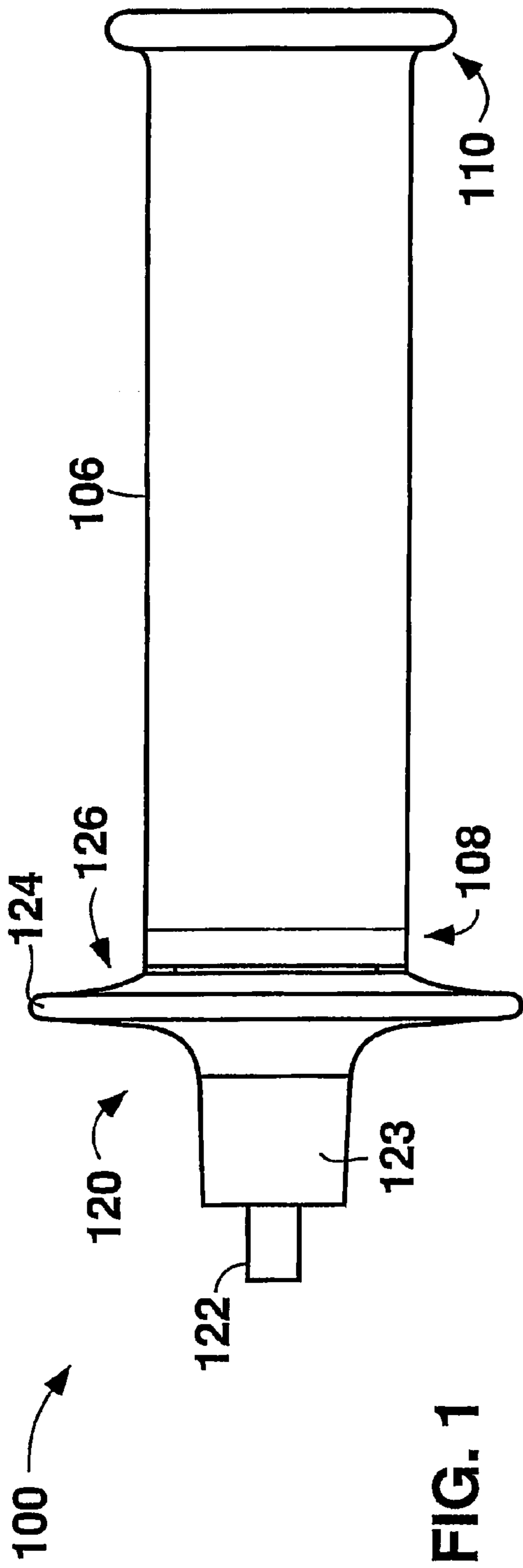

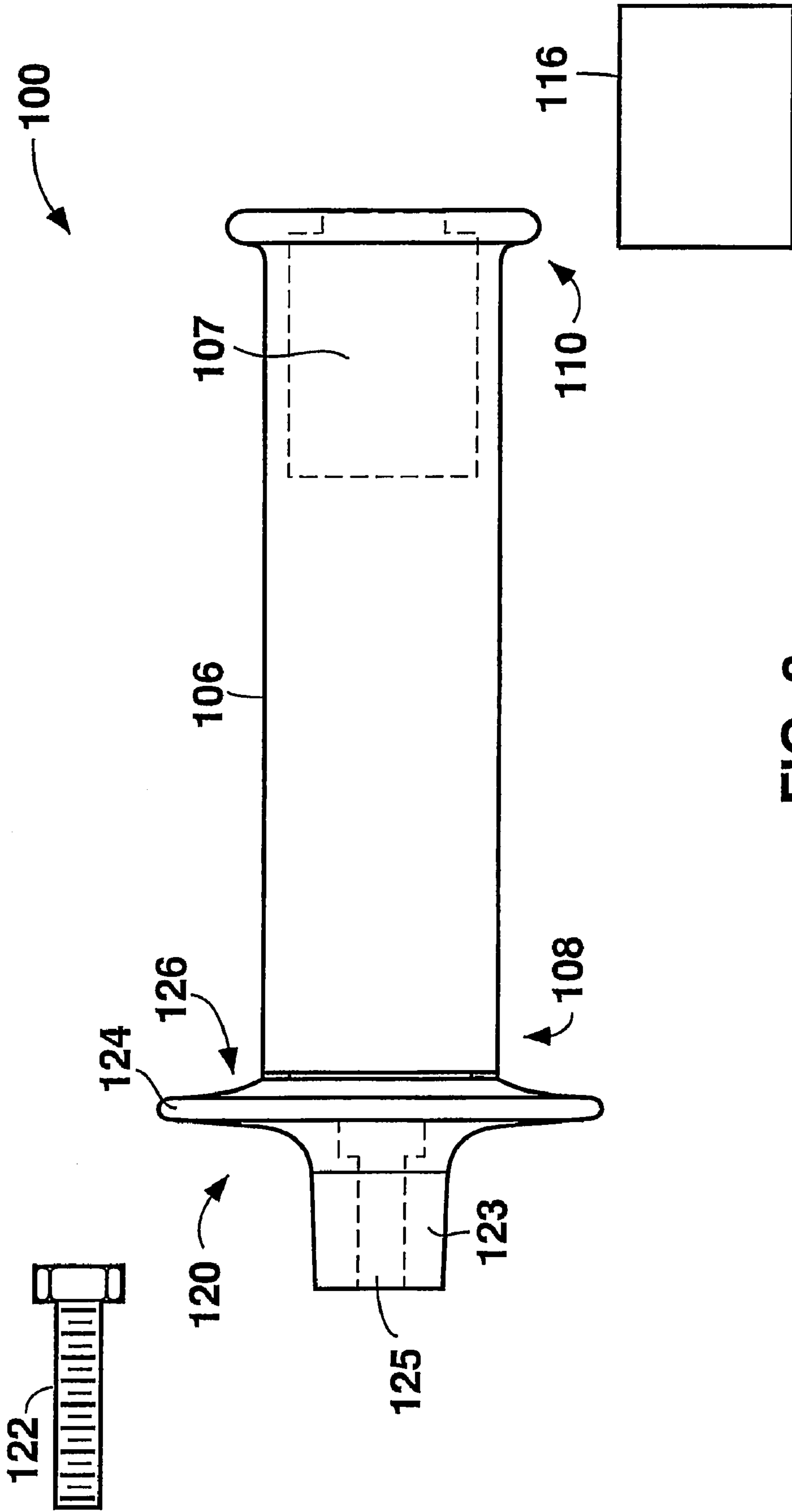

FIG. 3

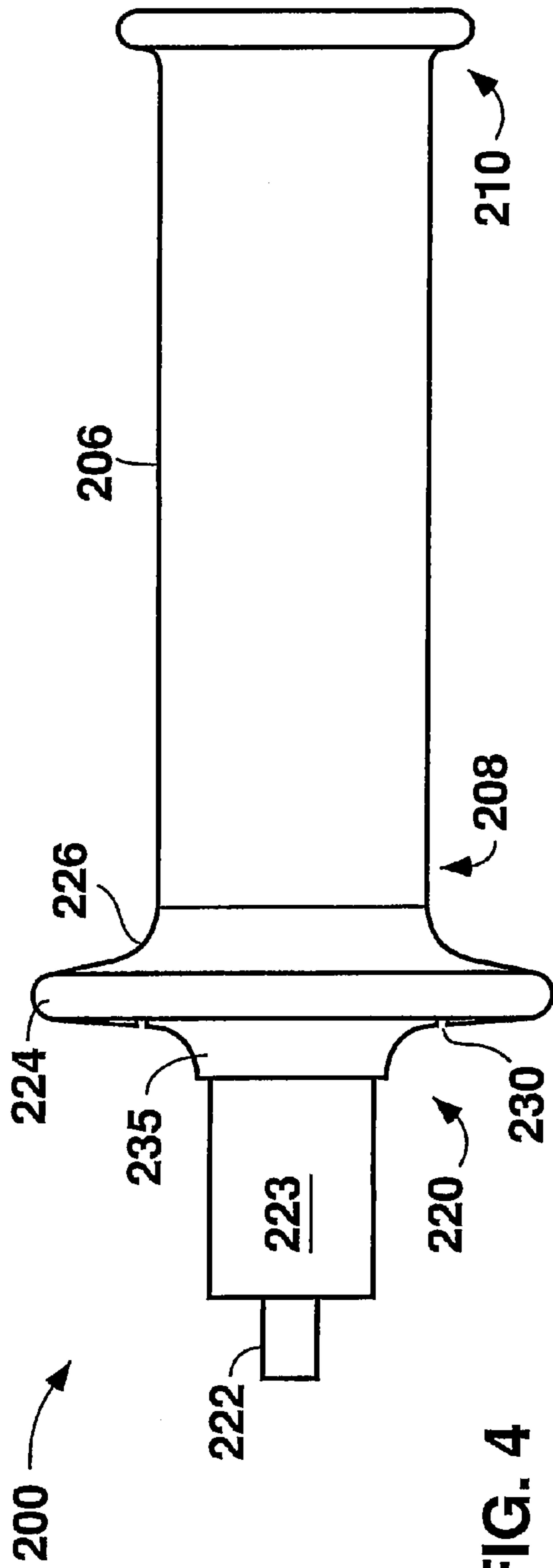

FIG. 4

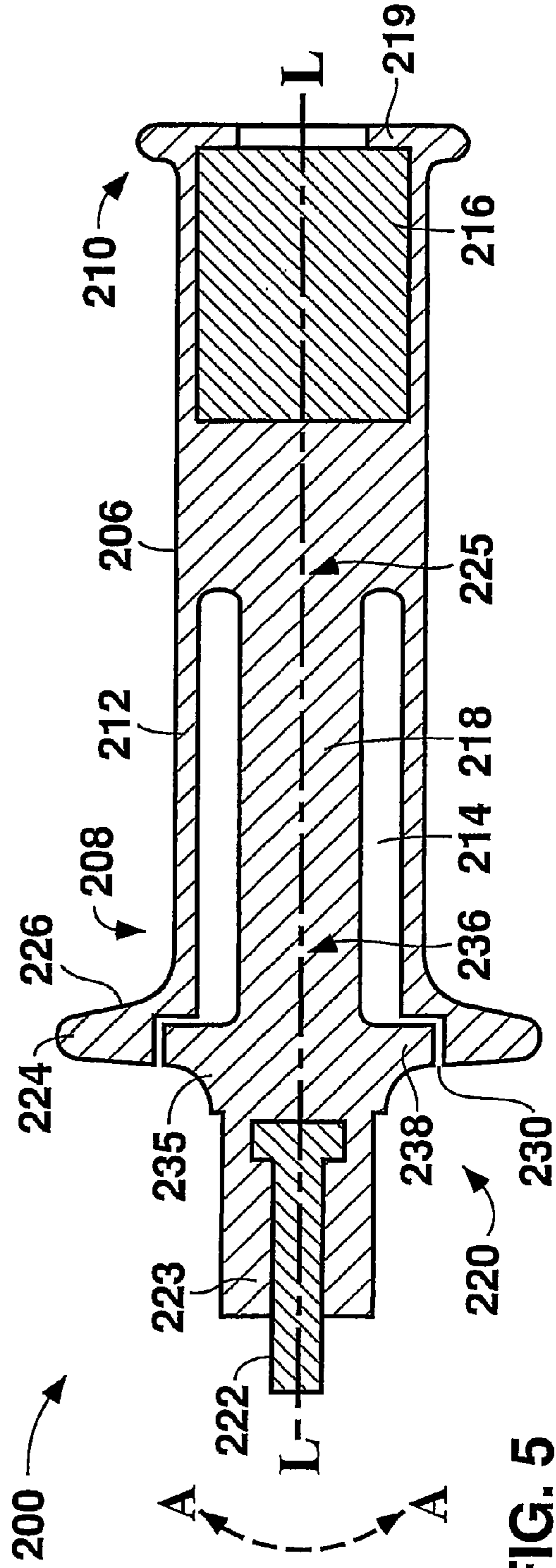

FIG. 5

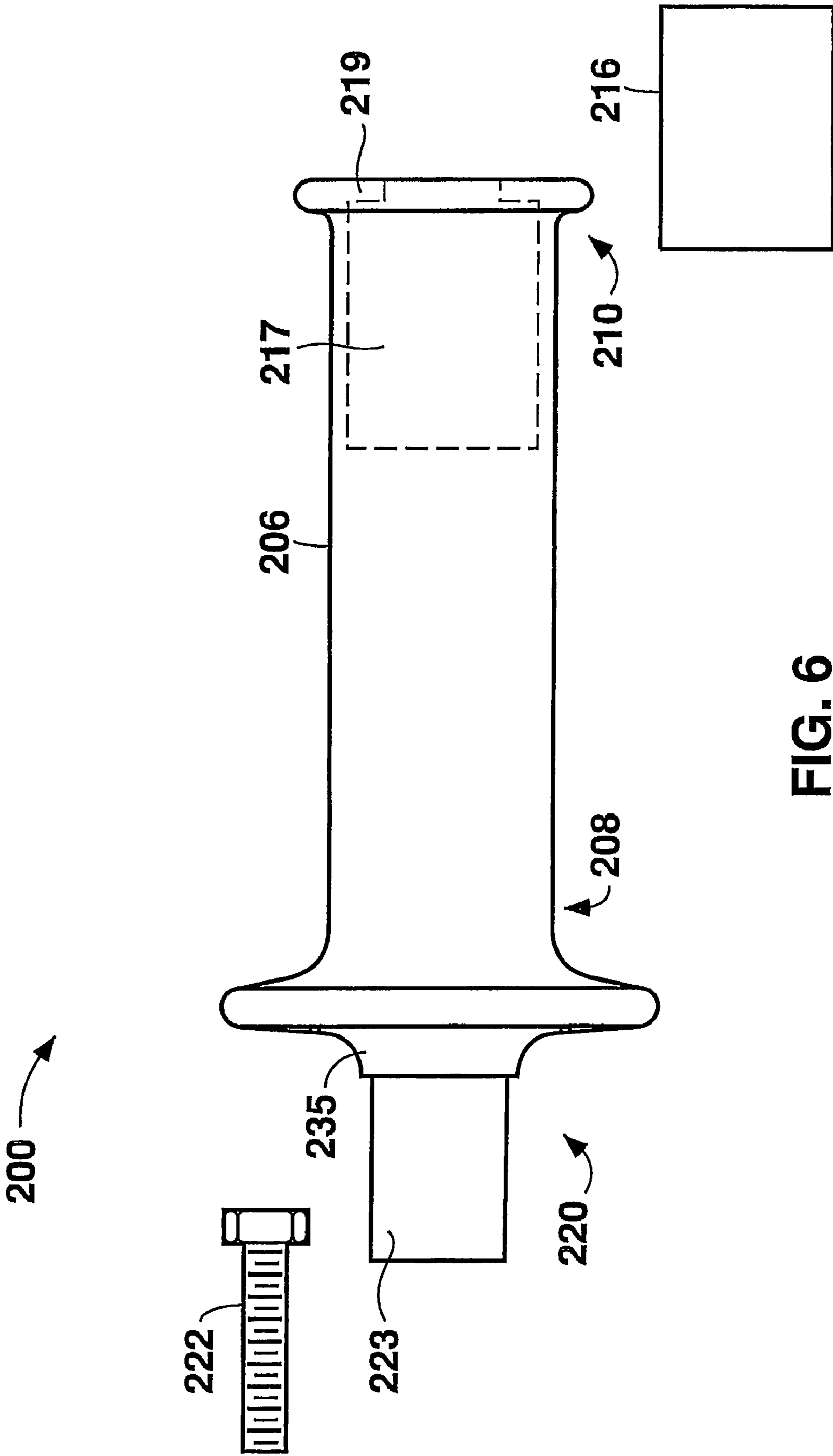

FIG. 6

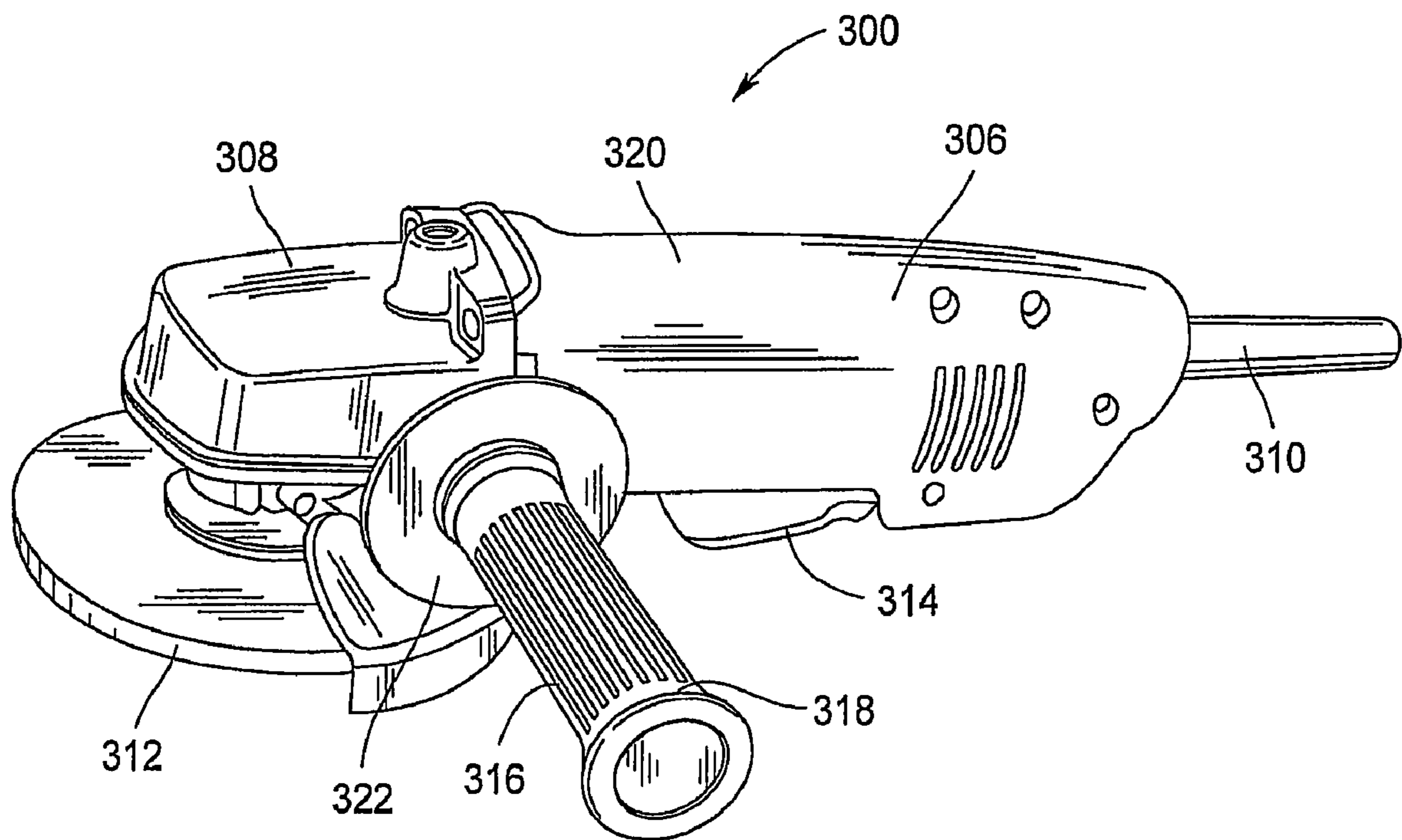

Fig. 7

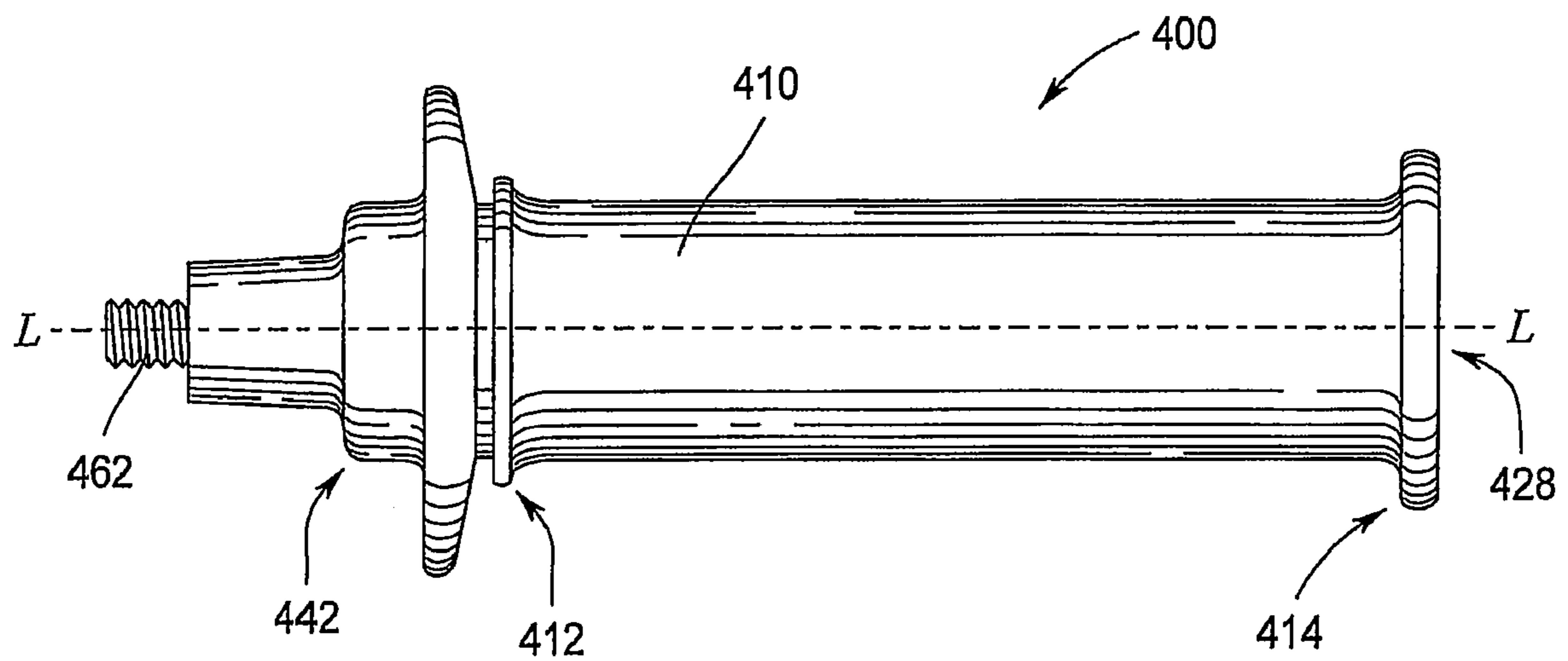

Fig. 8

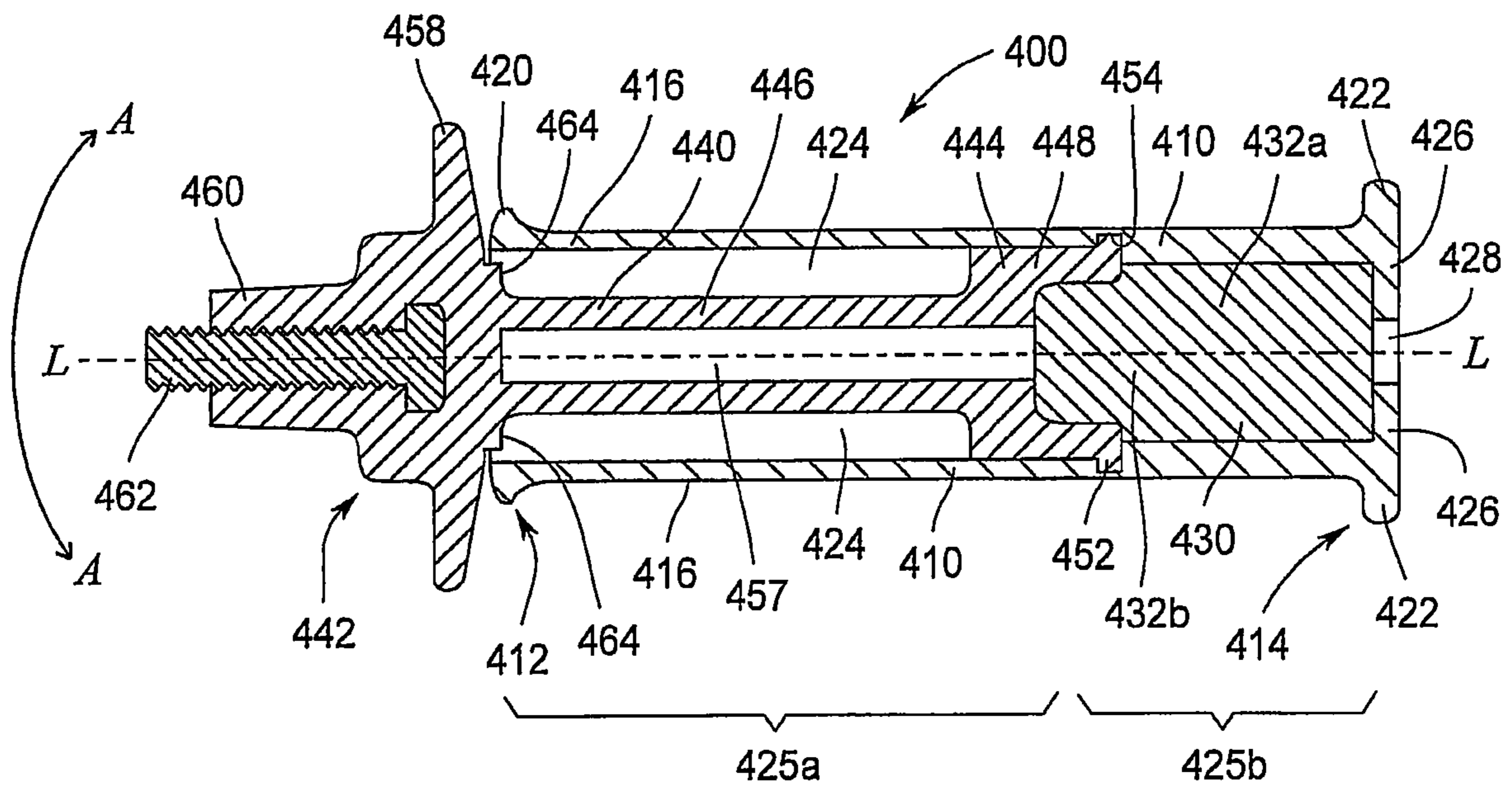

Fig. 9

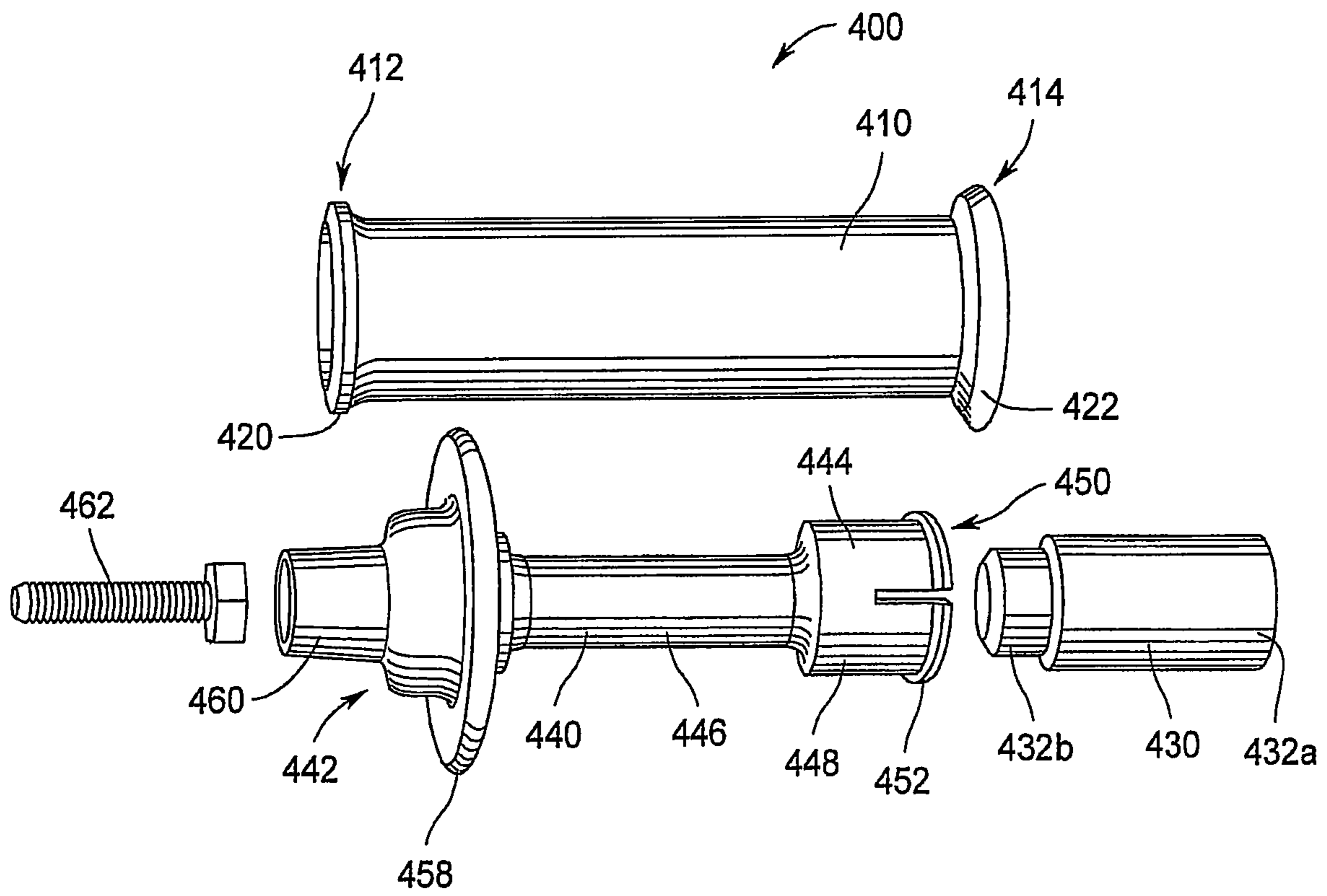

Fig. 10

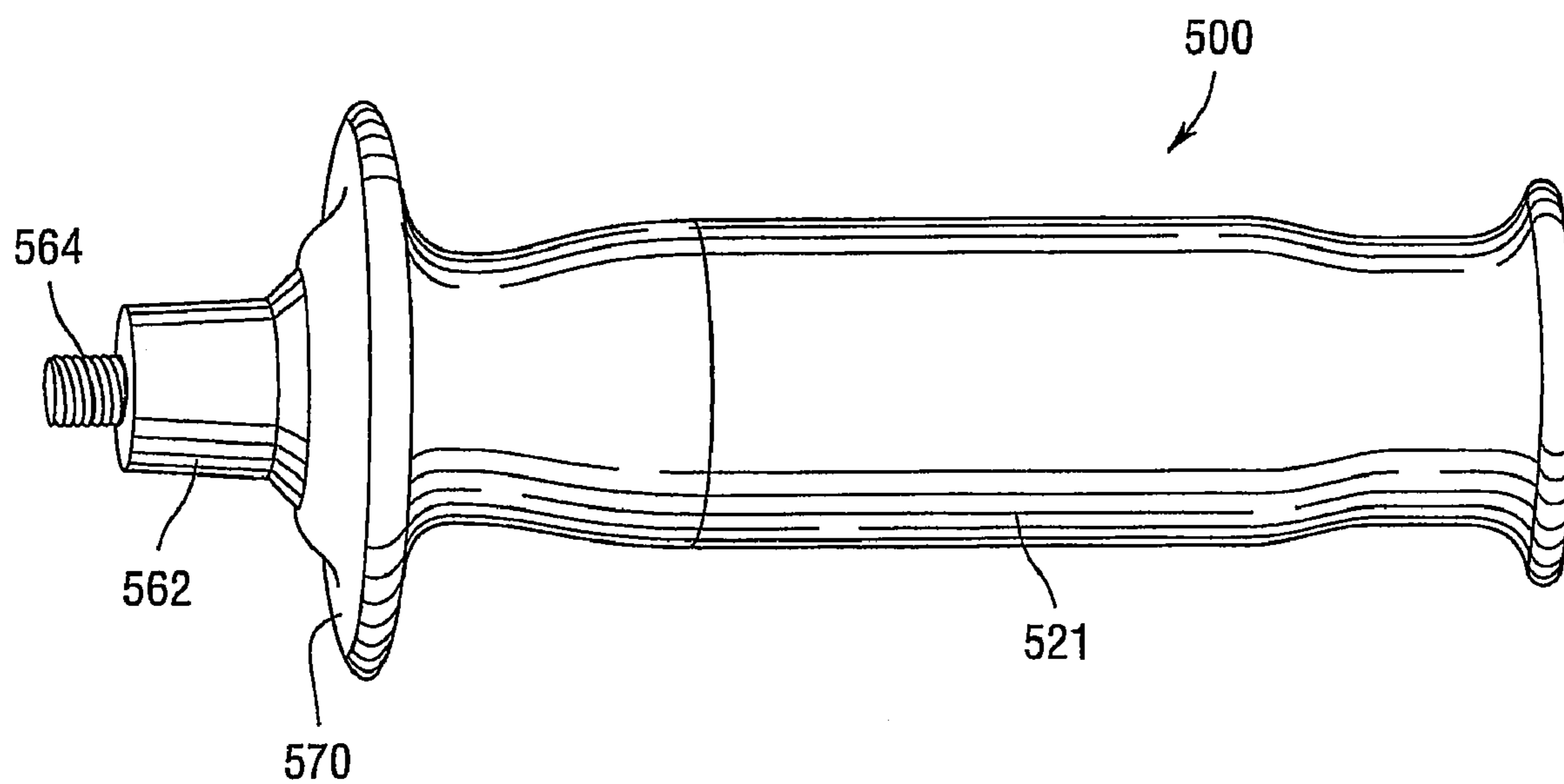

Fig. 11

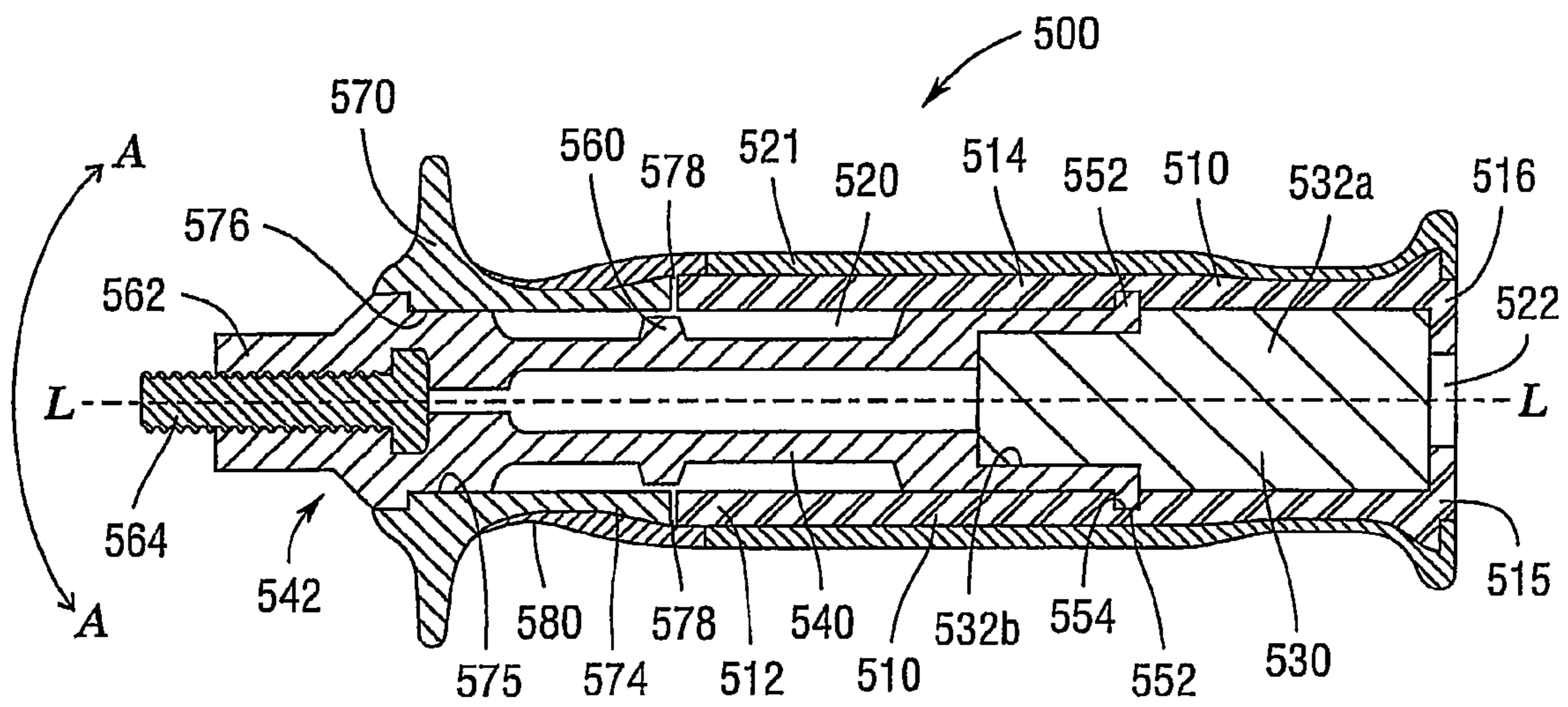

Fig.12

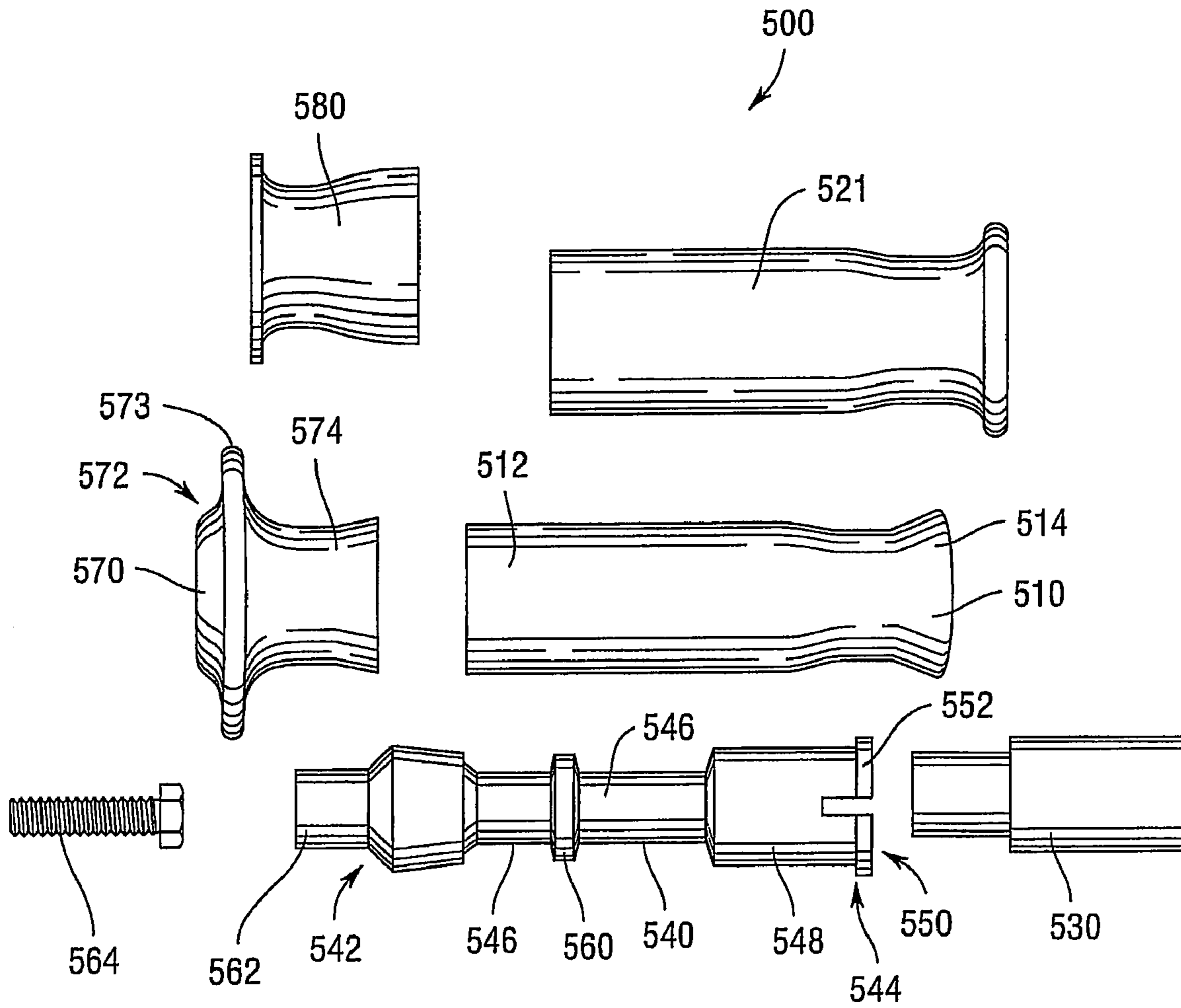

Fig.13

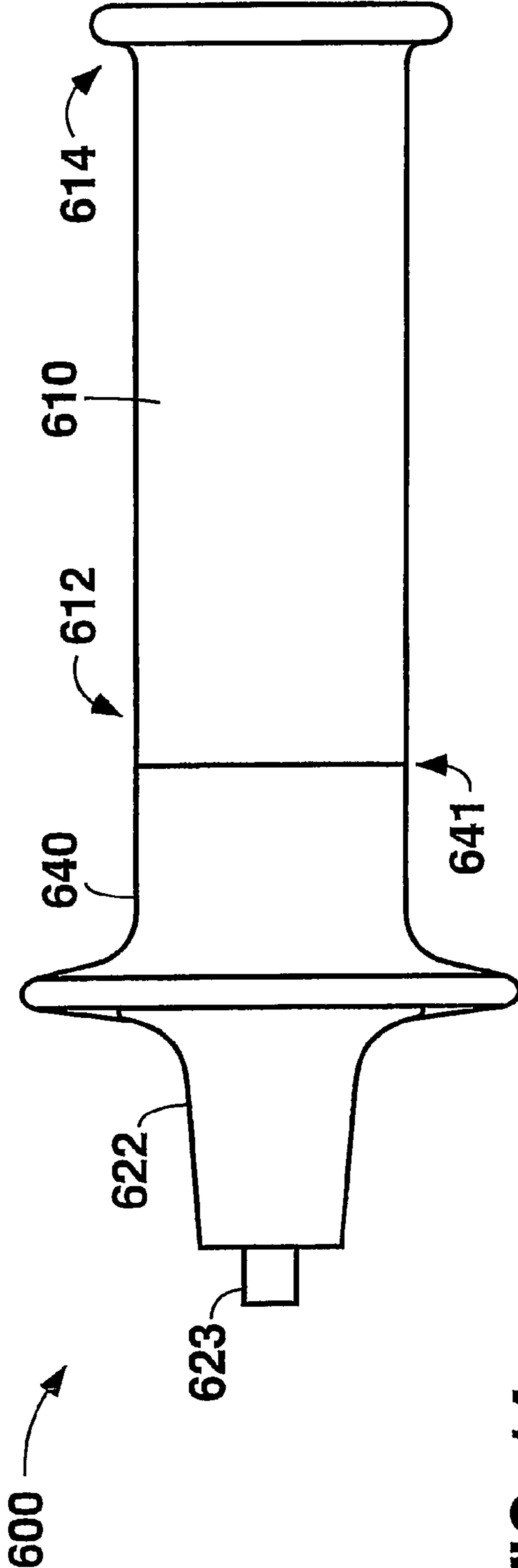

FIG. 14

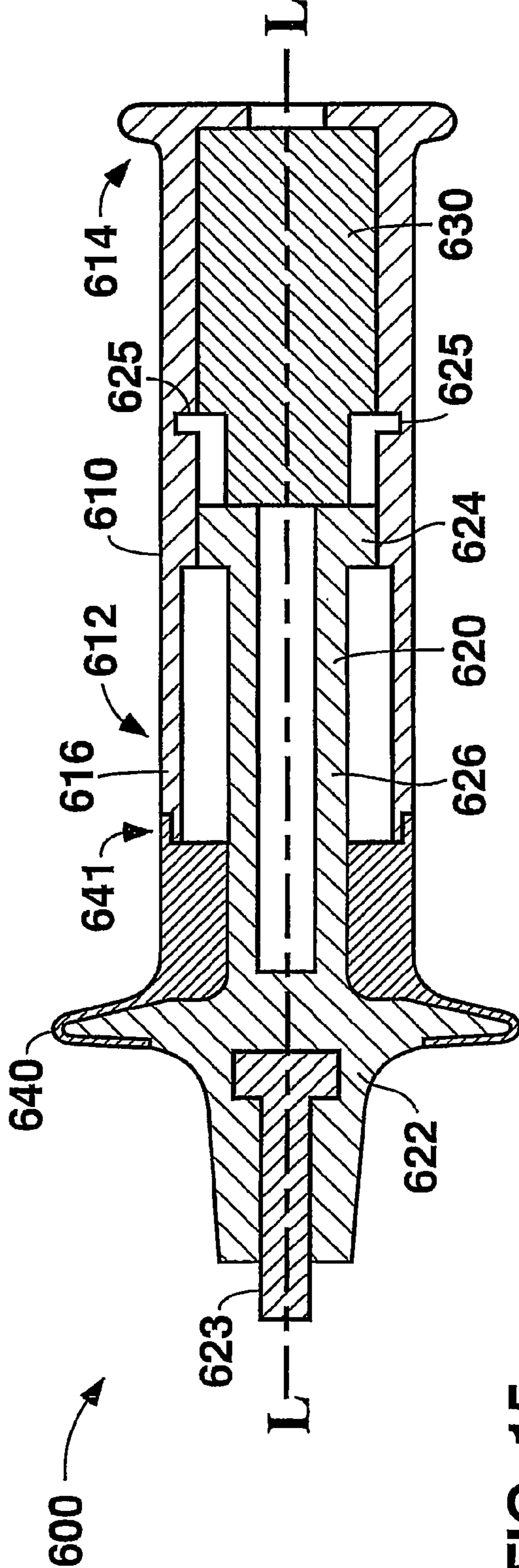

FIG. 15

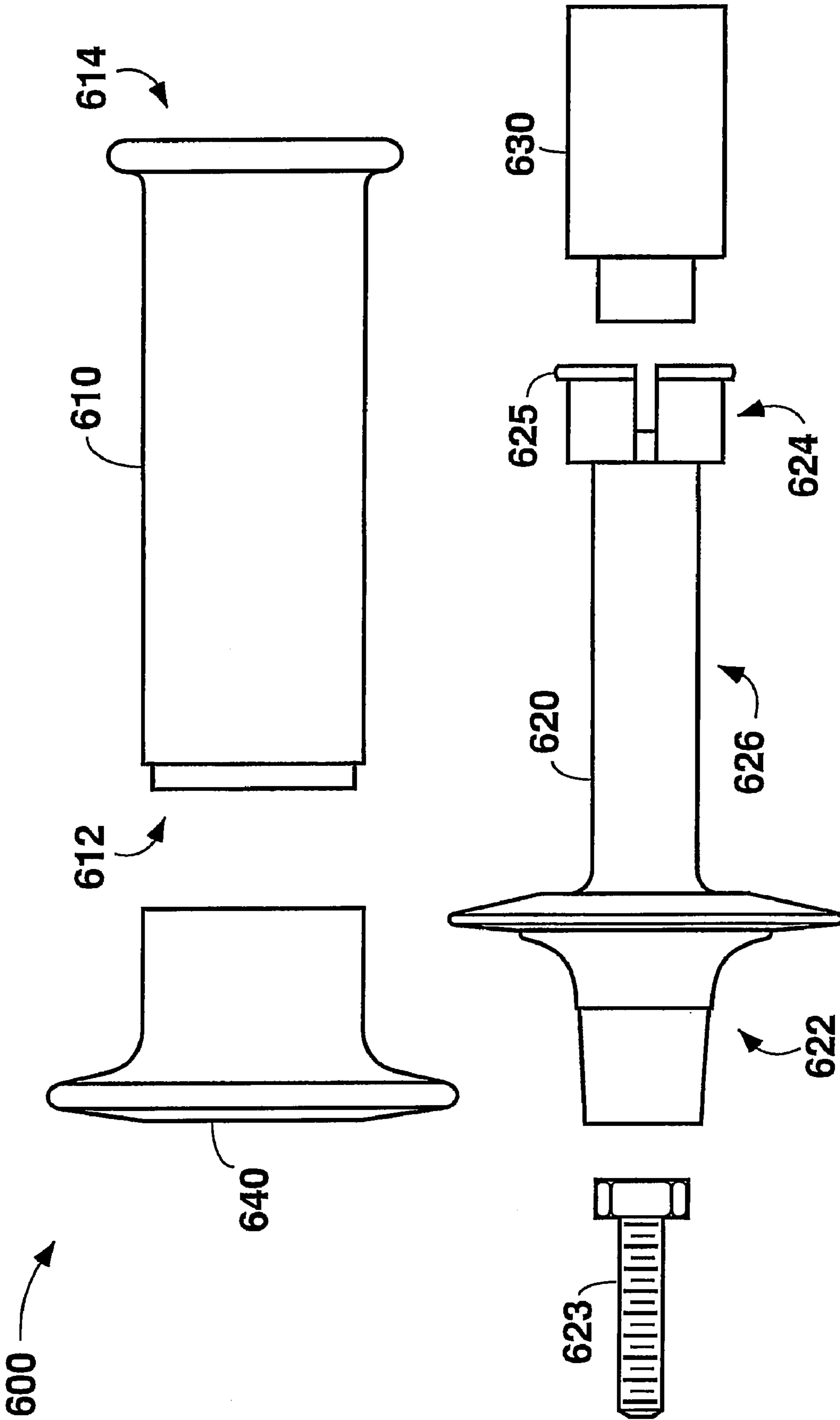

FIG. 16

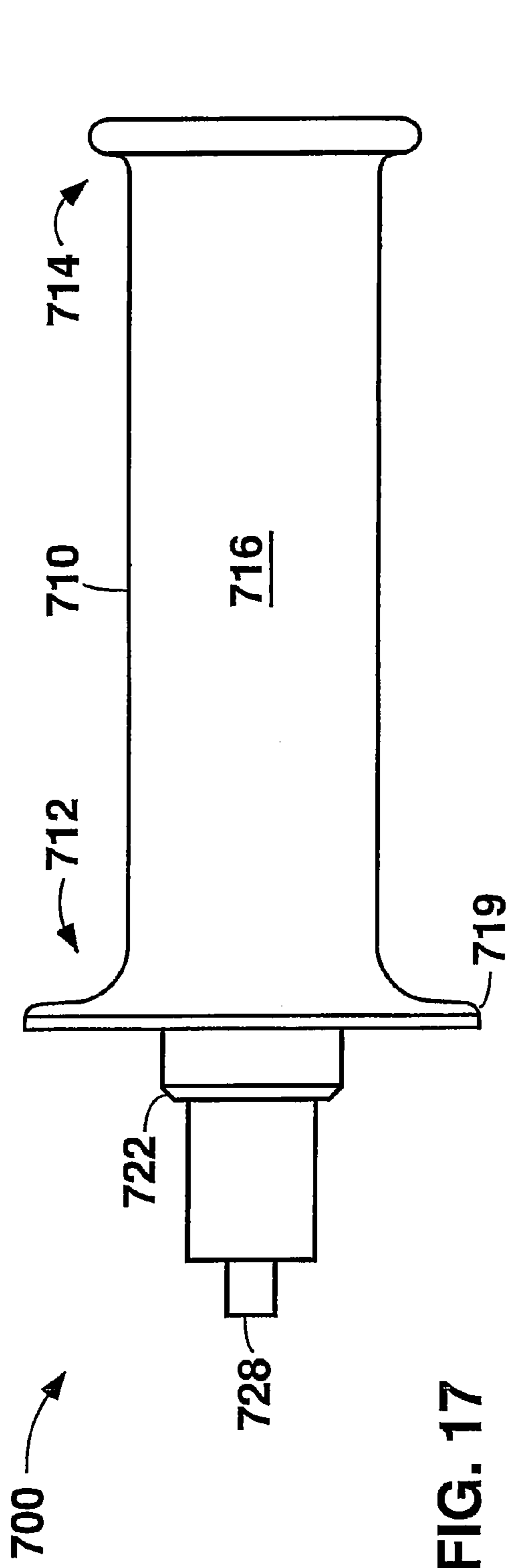

FIG. 17

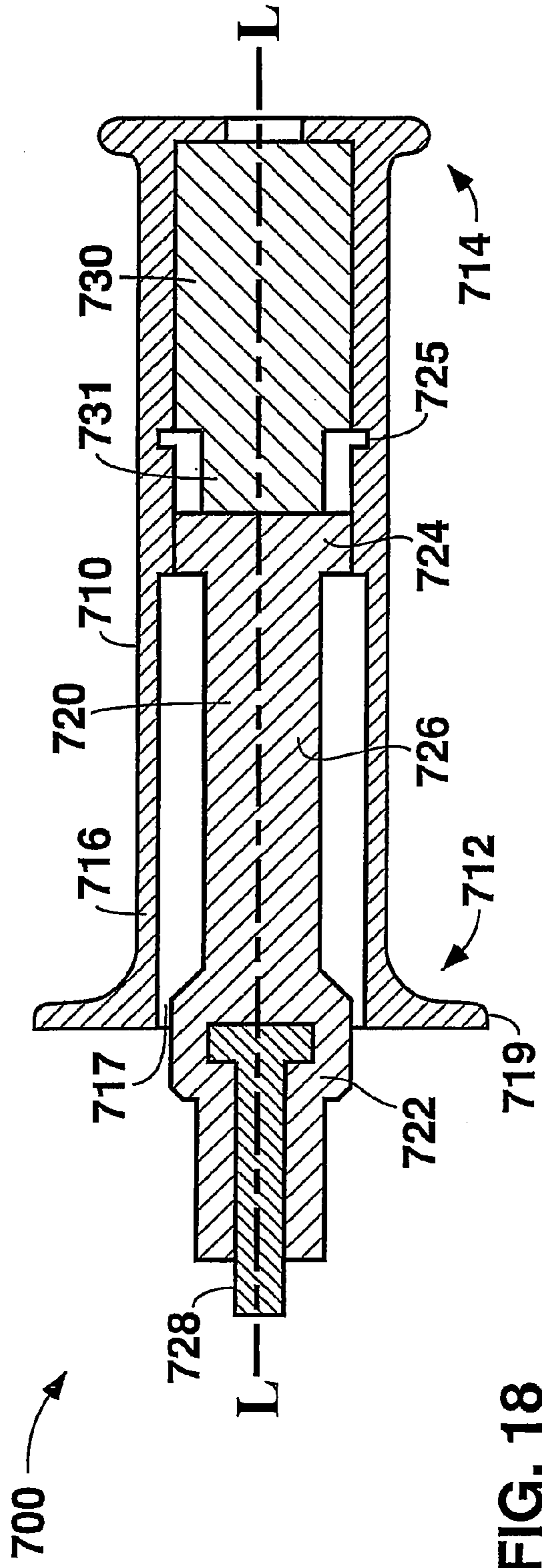

FIG. 18

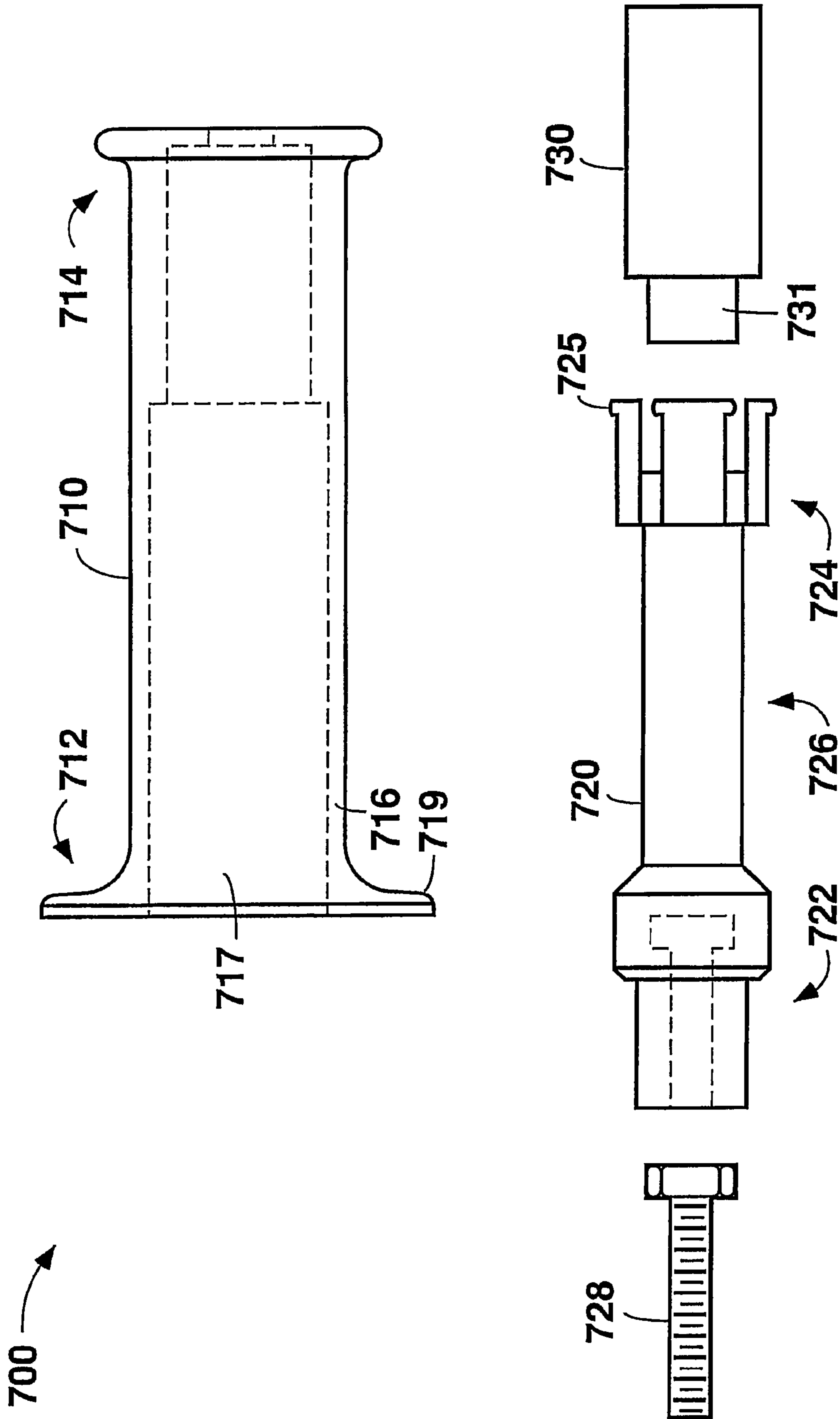
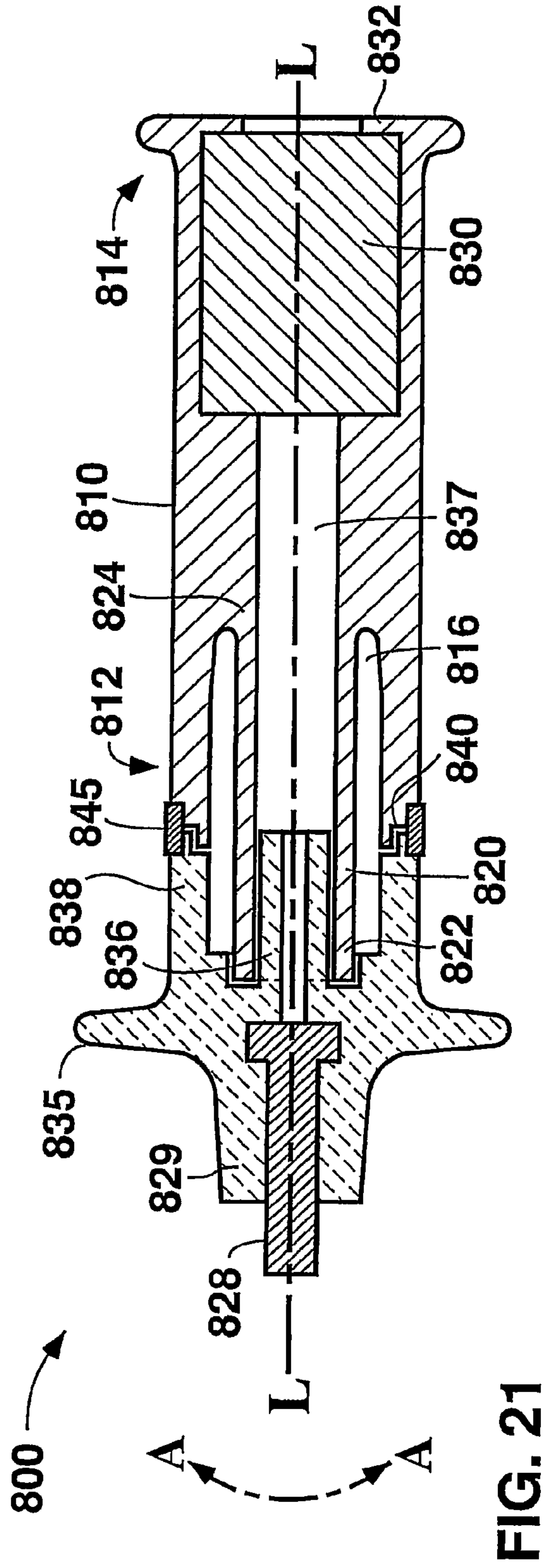
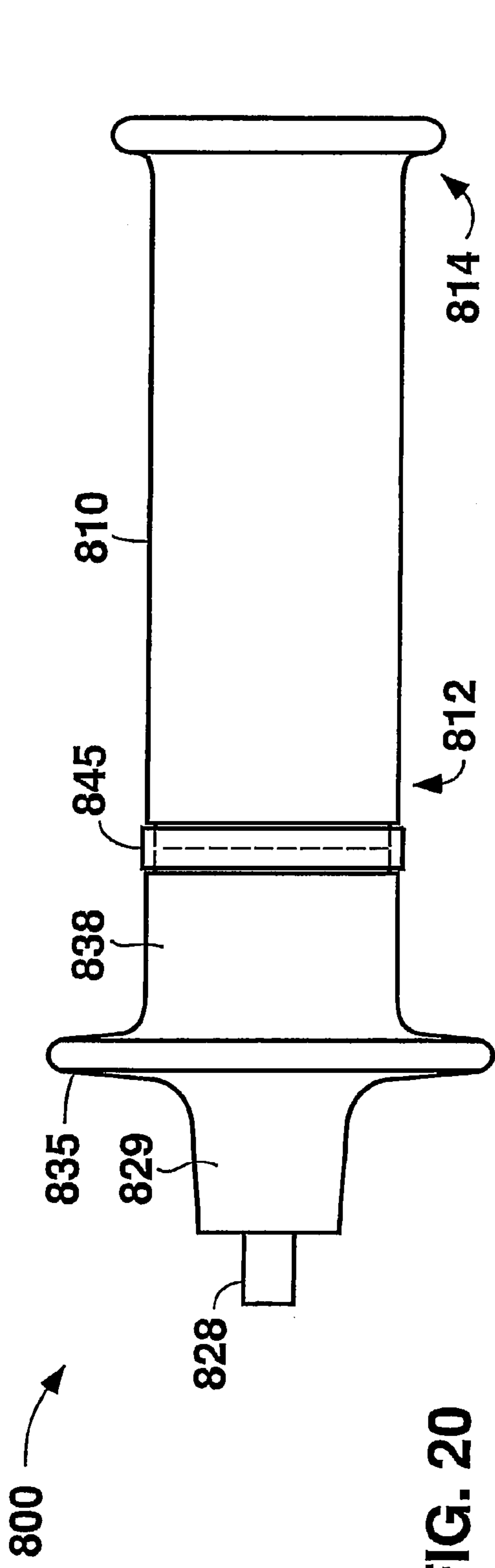

FIG. 19



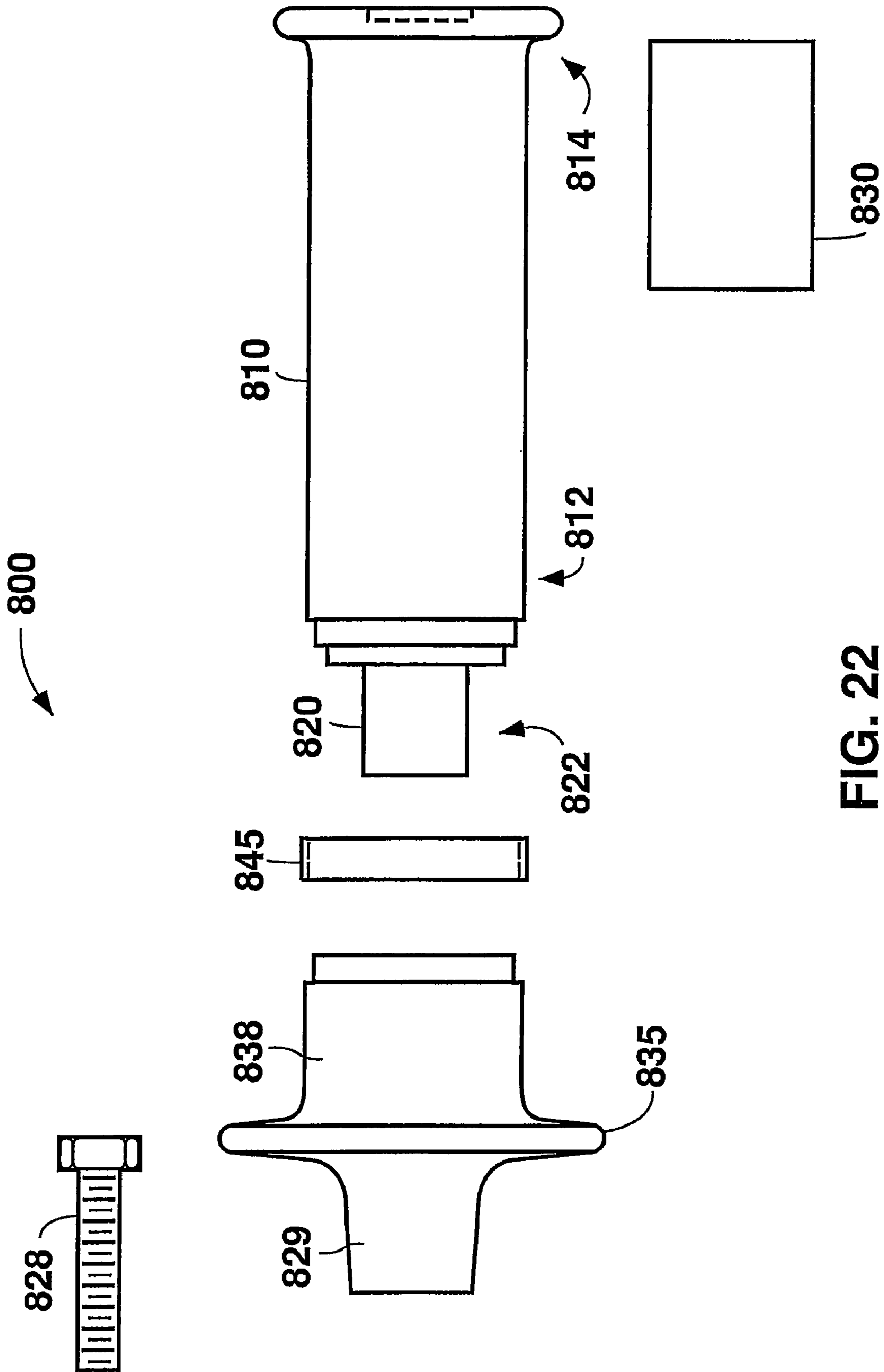

FIG. 22

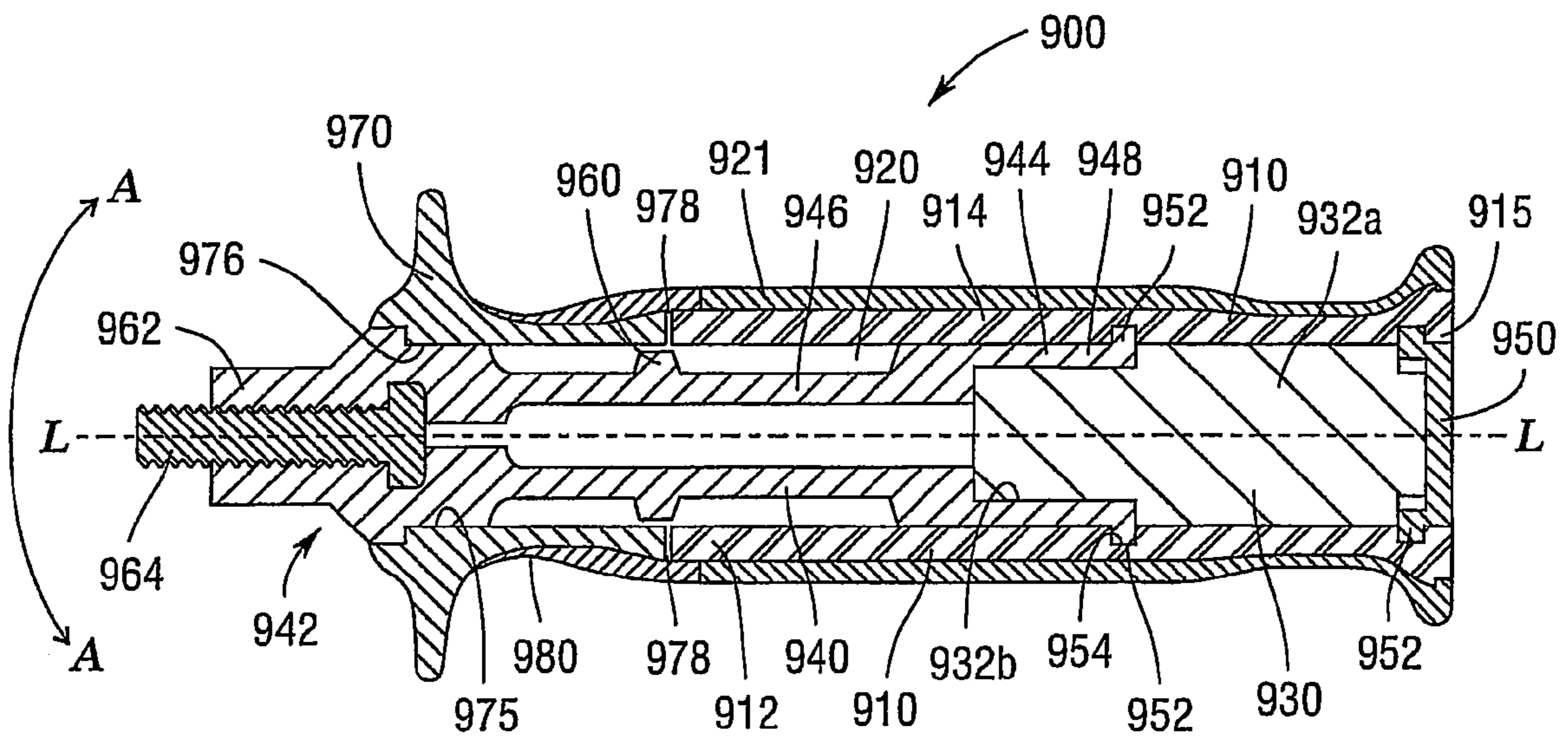

Fig.23

VIBRATION DAMPENING HANDLE FOR A POWERED APPARATUS

BACKGROUND OF THE TECHNOLOGY

1. Field of Technology

The present disclosure relates to vibration dampening components, and more particularly relates to vibration dampening handles for powered apparatus. Such powered apparatus include, without limitation, example, powered wood-working and metal working tools and other power tools.

2. Description of the Background of the Technology

Power tools and other powered apparatus can generate substantial vibration during operation. Power tools, for example, may include reciprocating and/or rotating tool members such as bits, discs, and belts and, as such, vibration can be exacerbated when the tool member contacts a workpiece. One specific example of a power tool including a rotating part is a hand-held grinder, which includes a rotating abrasive disk. The grinder will generate a base level of vibration when the motor is engaged and the disk is rotating, and at least the magnitude vibration will increase when the abrasive disk contacts and is abrading a workpiece.

An objective of certain prior power tool designs has been to provide handles that dampen (i.e., reduce the magnitude of) vibrations and thereby transmit a reduced level of vibrations to the hand of an operator grasping the handle. Dampening vibrations increases operator comfort and reduces hand fatigue, allowing an operator to comfortable use the power tool for extended periods. Dampening vibrations also can improve an operator's control of the power tool, which can be especially important when doing fine work such as finish work on wooden workpieces.

Certain previous attempts to address the vibration problem have focused on including in the handle some type of vibration absorbing elastic element. U.S. Pat. No. 5,365,637, for example, discloses a vibration absorbing power tool including an elongated gripping member with first and second ends and an inner bore extending along a longitudinal axis of the gripping member and opening on the first end. An elongated support member, disposed in the inner bore, extends coaxially along the longitudinal axis. Means for mounting the gripping member to a power tool is mounted at the gripping member's first end and is spaced from an end of the support member. The gripping member, which is a monolithic elastomeric body, includes a region forming a radially extending flexible flange between the support member and the mounting means. The flexible flange permits the handle to flex in a direction generally transverse to the longitudinal axis, permits slight translation of the handle along the longitudinal axis, and absorbs some part of the vibration reaching the handle.

U.S. Pat. No. 5,273,120 discloses a vibration dampening handle for a power tool including an elongated handle housing having a longitudinal axis of symmetry and a first end. A bore extends into the housing along the longitudinal axis and opens on the first end. A support member is connected to the housing and is coaxial with the longitudinal axis and extends into the bore. A hollow tubular elastic flex member is telescoped over the support member, extends into the bore, and is affixed to both the handle housing and support member. A mounting surface on the tool includes an outwardly extending apex to which the support member is connected. The handle can rock back and forth over the apex as the flex member is flexed by vibrations from the tool.

U.S. Pat. No. 5,170,532 discloses a vibration dampening power tool handle including a hollow tubular member having a bell-shaped socket at a first end. A second end of the tubular

member receives a stem portion of weighted mass, which is provided to reduce the handle's resonance frequency of the handle. The bell-shaped socket includes a circumferential groove formed on its inner periphery. A vibration insulating spring element, which may be a conical steel disc or membrane, is snapped into the circumferential groove. The spring element includes a central opening into which a mounting means may be disposed and connected to the power tool. Vibrational energy from the power tool is partially dissipated by the flexing motion of the spring element.

United States Patent Application Publication No. US 2004/0016082 A1 discloses a vibration absorbing power tool handle including a hollow tubular gripping member having first and second ends and an inner bore therethrough along a longitudinal axis of the gripping member. Two cylindrical elastic members having bores therethrough are disposed within the inner bore in a spaced apart relation near the first end of the gripping member. A rigid connecting member is disposed through and connected within the bores of the elastic members so that the connecting member can translate to some degree relative to the gripping member. An end of the connecting member extends beyond the first end of the gripping member and is connected to the power tool. The rigid connecting member acts to stiffen the handle, while the elastic members couple the gripping member to the connecting member and also absorb vibration transmitted from the power tool.

Certain other prior art power tool handle designs incorporate elements channeling the vibratory movement of the handle into less problematic translational modes. U.S. Pat. No. 5,769,174, for example, discloses a vibration dampening handle including a hollow space in which first and second base members are disposed. A surface of the first base member is parallel in an "x" direction and opposes a surface of the second base member, and the two base members are spaced apart in a "z" direction perpendicular to the "x" direction. Two parallel elongate flexible (elastic) beam members are connected to and span the "z" distance between the opposed base member's surfaces. The first base member may move within the handle in a "y" direction that is perpendicular to the "x" and "z" directions, but the first base member is restrained from moving in the "x" and "z" directions. This arrangement channels a portion of the vibratory loading on the handle to the "y" direction, and little angular deflection of the beam members occurs in the "x" and "z" directions. Accordingly, the handle is said to improve operator control by absorbing relative induced motion or vibration in one preferred direction, while retaining relative stiffness in the remaining two directions, and also by restraining the handle from torsional twist.

Despite the existence of the foregoing vibration dampening arrangements, there remains a need for innovative designs for power tool handles that reduce vibrations transmitted to the operator's hand. More generally, there remains a need for innovative handle designs that reduce transmitted vibration from other types of powered apparatus to an operator's hand.

SUMMARY

One aspect of the present disclosure is directed to a vibration dampening handle for a powered apparatus. The handle includes an elongate gripping member including a first end, a second end opposite the first end, a longitudinal axis extending through the first end and the second end, and a wall defining an inner bore and having an inner surface. The inner bore within the gripping member extends along the longitudinal axis at least partially through the gripping member and

3

opens on at least the first end of the gripping member. The handle also includes a mass disposed at the second end of the gripping member. An elongate elastic beam member is one of attached to and integral with the gripping member. The beam member extends along a region of the longitudinal axis and includes a portion that is disposed within the inner bore and is spaced apart from the inner surface of the gripping member. The beam member further includes a first end that extends beyond the inner bore and the first end of the gripping member. The first end of the beam member includes a fastening member adapted to connect the handle to the powered apparatus. In certain embodiments of the vibration dampening handle, the first and, optionally, also the second natural frequencies of vibration of the beam member are less than a predetermined frequency of vibration of the powered apparatus.

An additional aspect of the present disclosure is directed to a handle for a power tool including a driven tool member, wherein the handle is capable of reducing transmitted vibration to the hand of an operator gripping the handle. The handle includes a gripping member that includes an elongate portion comprising a first end, a second end opposite the first end, and a wall that defines an inner bore and includes an inner surface. The inner bore extends along at least a portion of a longitudinal axis of the gripping member and opens on at least the first end of the gripping member. The handle also includes a mass disposed at the second end of the gripping member. An elongate elastic beam member is one of attached to and integral with the gripping member. The beam member extends along a region of the longitudinal axis, and at least a portion of the beam member is within the inner bore and spaced apart from the wall of the gripping member. At least a portion of a first end of the beam member extends beyond inner bore and the first end of the gripping member, and includes a fastening member to connect the handle to the power tool. In certain non-limiting embodiments of the power tool handle, the first and, optionally, also the second natural frequencies of vibration of the beam member are less than a predetermined frequency of vibration of the power tool.

A further aspect of the present disclosure is directed to a powered apparatus including a handle manipulated by an operator of the powered apparatus and which is adapted to dampen vibration generated by the apparatus. The handle comprises an elongate gripping member including a first end, a second end opposite the first end, a longitudinal axis extending through the first end and the second end, and a wall defining an inner bore and having an inner surface. The inner bore extends along the longitudinal axis at least partially through the gripping member and opens on at least the first end. The handle also includes a mass disposed at the second end of the gripping member. An elongate elastic beam member is attached to the gripping member and extends along a region of the longitudinal axis. At least a portion of the beam member is disposed within the inner bore and is spaced apart from the inner surface of the wall of the gripping member. The beam member includes a first end that extends beyond the first end of the gripping member. The first end includes a fastening member adapted to connect the handle to the powered apparatus. In certain embodiments of the powered apparatus, a predetermined frequency of vibration of the powered apparatus is higher than the first and, optionally, also the second natural frequencies of vibration of the beam member of the handle.

Yet another aspect of the present disclosure is directed to a power tool including a driven tool member and a vibration dampening handle for manipulating the power tool. The handle comprises a gripping member that includes an elongate

4

griping member including a first end, a second end opposite the first end, and a wall defining an inner bore and including an inner surface. The inner bore extends along at least a region of a longitudinal axis of the gripping member and opens on at least the first end of the gripping member. The handle also includes a mass disposed at the second end of the gripping member. An elongate elastic beam member is one of attached to and integral with the gripping member, and extends along a region of the longitudinal axis. At least a portion of the beam member is within the inner bore and is spaced apart from the wall of the gripping member. At least a portion of a first end of the beam member extends beyond the inner bore and the first end of the gripping member, and includes a fastening member to connect the handle to the power tool. In certain non-limiting embodiments of the power tool, the first and, optionally, also the second resonance natural frequencies of vibration of the beam member of the handle are lower than a predetermined frequency of vibration of the power tool. The predetermined frequency may be, for example, a frequency of vibration of the power tool when the driven tool member is under load.

BRIEF DESCRIPTION OF THE DRAWINGS

The features and advantages of the alloys and articles described herein may be better understood by reference to the accompanying drawing in which:

FIG. 1 is a plan view of a first embodiment of a vibration dampening handle constructed according to the present disclosure;

FIG. 2 is a cross-sectional view of the embodiment of FIG. 1, wherein the handle is sectioned through a longitudinal axis of the handle;

FIG. 3 is an assembly view depicting several component parts of the embodiment of FIG. 1;

FIG. 4 is a plan view of a second embodiment of a vibration dampening handle constructed according to the present disclosure;

FIG. 5 is a cross-sectional view of the embodiment of FIG. 4, wherein the handle is sectioned through a longitudinal axis of the handle;

FIG. 6 is an assembly view depicting several component parts of the embodiment of FIG. 4;

FIG. 7 is a perspective view of a powered small angle grinder including an embodiment of a vibration dampening handle constructed according to the present disclosure;

FIG. 8 is a plan view of a third embodiment of a vibration dampening handle constructed according to the present disclosure;

FIG. 9 is a cross-sectional view of the embodiment of FIG. 8, wherein the handle is sectioned through a longitudinal axis of the handle;

FIG. 10 is an assembly view depicting several component parts of the embodiment of FIG. 8;

FIG. 11 is a plan view of a fourth embodiment of a vibration dampening handle constructed according to the present disclosure;

FIG. 12 is a cross-sectional view of the embodiment of FIG. 11, wherein the handle is sectioned through a longitudinal axis of the handle;

FIG. 13 is an assembly view depicting several component parts of the embodiment of FIG. 11;

FIG. 14 is a plan view of a fifth embodiment of a vibration dampening handle constructed according to the present disclosure;

5

FIG. 15 is a cross-sectional view of the embodiment of FIG. 14, wherein the handle is sectioned through a longitudinal axis of the handle;

FIG. 16 is an assembly view depicting several component parts of the embodiment of FIG. 14;

FIG. 17 is a plan view of a sixth embodiment of a vibration dampening handle constructed according to the present disclosure;

FIG. 18 is a cross-sectional view of the embodiment of FIG. 17, wherein the handle is sectioned through a longitudinal axis of the handle;

FIG. 19 is an assembly view depicting several component parts of the embodiment of FIG. 17;

FIG. 20 is a plan view of a seventh embodiment of a vibration dampening handle constructed according to the present disclosure;

FIG. 21 is a cross-sectional view of the embodiment of FIG. 20, wherein the handle is sectioned through a longitudinal axis of the handle;

FIG. 22 is an assembly view depicting several component parts of the embodiment of FIG. 20; and

FIG. 23 is a cross-sectional view of an eighth embodiment of a vibration dampening handle constructed according to the present disclosure.

DESCRIPTION OF CERTAIN NON-LIMITING EMBODIMENTS

Other than in the operating examples, or where otherwise indicated, all numbers expressing dimensions, quantities of materials and the like used in the present description and claims are to be understood as being modified in all instances by the term "about". Accordingly, unless indicated to the contrary, any numerical parameters set forth in the following description and the attached claims are approximations that may vary depending upon the desired properties one seeks to obtain in articles according to the present disclosure. At the very least, and not as an attempt to limit the application of the doctrine of equivalents to the scope of the claims, each numerical parameter should at least be construed in light of the number of reported significant digits and by applying ordinary rounding techniques

Notwithstanding that the numerical ranges and parameters setting forth the broad scope of the present disclosure are approximations, the numerical values set forth in any specific examples herein are reported as precisely as possible. Any numerical values, however, inherently contain certain errors, such as, for example, equipment and/or operator errors, necessarily resulting from the standard deviation found in their respective testing measurements. Also, it should be understood that any numerical range recited herein is intended to include the range boundaries and all sub-ranges subsumed therein. For example, a range of "1 to 10" is intended to include all sub-ranges between (and including) the recited minimum value of 1 and the recited maximum value of 10, that is, having a minimum value equal to or greater than 1 and a maximum value of equal to or less than 10

FIGS. 1 through 3 schematically depict one embodiment of a vibration dampening handle according to the present disclosure. FIG. 2 is a cross section taken through a longitudinal axis of one non-limiting embodiment of a vibration dampening handle for a power tool or other powered apparatus according to the present disclosure. The vibration dampening handle 100 is designed so that it can inhibit the transmission of vibration from the powered apparatus during its operation to the hand of an operator gripping the handle. The handle includes an elongate gripping member 106 having a first end

6

108, an opposed second end 110, and a longitudinal axis L-L that intersects both the first end 108 and the second end 110. The gripping member 106 may be contoured or otherwise shaped so as to facilitate gripping by the hand of an operator of the powered apparatus. The gripping member 106 may be generally symmetrical or asymmetrical about the longitudinal axis. For example, the gripping member 106 may have a contour that is generally cylindrical, for example, symmetrical about the longitudinal axis L-L. Alternatively, the gripping member 106 may have a contour that is asymmetrical about the longitudinal axis L-L such as, for example, a handlebar grip-shaped contour providing specific contour features accommodating the positions of the operator's fingers. More generally, the gripping member 106 may have any shape suitable for manipulation by an operator of the powered apparatus and, preferably, such shape is comfortable and provides requisite control of the apparatus when gripped by the operator. In certain non-limiting embodiments of the handle 100, the gripping member 106 is constructed of a hard plastic such as, for example, acrylonitrile butadiene styrene (ABS), or any other suitably hard material using conventional manufacturing techniques such as, for example, blow or injection molding. Also, all or a portion of its outer peripheral surface of the gripping member 106 may be sheathed or otherwise covered with a resilient material (not shown in FIGS. 1 through 3) to improve grip comfort.

The gripping member 106 includes a peripheral wall 112 that defines an inner bore 114 within the gripping member 106. In certain non-limiting embodiments of the handle 100, and as shown on FIG. 1, the inner bore 114 extends within the gripping member 106 along at least a region of the longitudinal axis L-L. In certain other embodiments, the inner bore 114 may extend entirely through the gripping member 106, thereby opening on both the first end 108 and the second end of the gripping member 110. Alternatively, as shown in the embodiment 100 depicted in FIGS. 1 through 3, the inner bore 114 extends along the longitudinal axis L-L through only a portion of the length of the gripping member 106 and opens only on the first end 108 of the gripping member 106.

Handle 100 further includes a mass 116 (a weight) that is disposed at or near the second end 110 of the gripping member 106. A purpose of the mass 116 is to increase the weight of the gripping member 106 at or near the second end 110 and relative to the first end 108 of the gripping member 106. The mass 116 may be, for example, a metallic or ceramic member, or may be composed of any material having a density greater than the material from which the gripping member 106 is constructed. The gripping member 106 is designed so that the mass 116 may be disposed and securely retained in its position at or near the second end of the gripping member 106. This may be achieved by various means, including providing a cavity 107 at the second end 110 dimensioned to accept the mass 116 and retaining the mass 116 in the cavity using, for example, a cap 117 secured over the cavity or a fastener or a suitable adhesive that secures the mass 116 within the cavity 107. In an alternate arrangement not shown in FIGS. 1 through 3, the inner bore formed in the gripping member extends into the second end of the gripping member, and the mass is disposed within the inner bore at the second end and secured in that position. In yet another alternate arrangement, the gripping member is made from a plastic material, and the mass is molded within the second end of the gripping member during fabrication of the gripping member. The preferred arrangement for disposing the mass within the second end of the gripping member may be influenced by the relative costs associated with manufacturing the vibration dampening handle by the various options.

The vibration dampening capability of the handle **100** is facilitated by including in the handle **100** an elastic beam member **118** that is positioned within the inner bore **114**. The elastic beam member **118** originates from the vicinity of the second end **110** of the gripping member **106** and extends generally along the longitudinal axis L-L to the first end **108** of the gripping member **106**. A first end **120** of the beam member **118** extends beyond the first end **108** of the gripping member **106** and includes a fastening member **122** disposed in a cavity **125**. The fastening member **122** is for connecting the handle **100** to the powered apparatus. The fastening member **122** is secured to collar **123** and may have any suitable form. For example, the fastening member **122** may be a threaded member. To secure the handle **100** to the powered apparatus, the collar **123** and fastening member **122**, for example, may be secured within a bore in a housing of the powered apparatus. The first end **120** of the beam member **118** may have any suitable shape. For example, as suggested in FIG. 1, the first end **120** may include an annular radial projection **124** having a curved side region **126**, which an operator's hand may abut when gripping the handle **100** and which limits the hand from contacting the surface of the powered apparatus housing to which the handle **100** is connected.

As shown in FIG. 2, a second end **123** of the beam member **118** is integral with the material from which the gripping member **106** is constructed in the region **121**. As shown in connection with other possible embodiments described herein, however, one possible alternative arrangement is a handle design wherein the second end of the beam member is configured to mate with a region of the gripping member and thereby securely connect the members together. Thus, handle **100** differs from several of the other embodiments discussed below in that the gripping member **106** and the beam member **118** are an integral part (i.e., one piece). Accordingly, although the term "member" is used in the present description (and in the claims) in connection with the gripping member, the beam member, and the fastening member, such use does not preclude the possibility that two or more of the gripping member, the beam member, and the fastening member are portions or regions of a single integral part, or that a single "member" is comprised of two or more elements or parts assembled to provide the member. In relation to FIG. 3, for example, the second end **123** of the beam member **118** is integral with the gripping member **106**.

As further shown in FIG. 2, a portion of the beam member **118** within the inner bore **114** is spaced away from an inner surface **127** of the wall of the gripping member **106**. The beam member **118** is made of a material having elastic properties such as, for example, a plastic such as ABS. The beam member **118** and gripping member **106** are dimensioned and positioned so that, as suggested by curved line A-A, the beam member **118** may be elastically laterally deflected through a range of motion relative to the wall **112** of the gripping member **106**. The propensity of the beam member **118** to move in response to an applied force may be adjusted by including a resilient material, such as a plastic or a rubber material, in all or a portion of the space **114** between the beam member **118** and the wall **112**. Also, as shown in FIG. 2, annular shoulder **130** of first end **120** of the beam member **118** opposes and is spaced apart from wall **112** of the gripping member **106**, and the remainder of first end **120** extends beyond the gripping member **106**. As will be understood from FIG. 2, the range of deflection of the beam member **118** relative to the gripping member **106**, indicated by the curved arrow A-A, is limited by the width of the gap provided between shoulder **130** and the inner wall **127**.

Given that the first end **120** of the beam member is connected to the powered apparatus by fastening member **122**, vibrations generated, for example, by the motor of the powered apparatus will be transmitted to the handle **100** and to the operator's hand. An objective of the present disclosure is to reduce the vibration experienced in this way by the operator. In that regard, a characteristic of the handle **100** is that the beam member **118** may be "tuned" so as to have predetermined natural or standing frequencies, or "modes", of vibration. The modes of vibration of the beam member **118** may be affected by adjusting parameters of handle **100** including: (1) the weight and position of the mass **116**; (2) the shape (for example, circular cross-section, square cross-section, or beam with ribs) and dimensions (length, diameter, width) of the beam member **118**; and (3) the material from which the beam member **118** is constructed. The stiffness characteristics of the beam member **118** are affected by, for example, material of construction, beam length, and beam member wall thickness (if the beam is hollow) or beam member diameter (if the beam is solid).

According to one aspect of the present disclosure, the first and, optionally, also the second natural frequencies of vibration of the beam member **118** of handle **100** are chosen (by appropriate selection of the foregoing parameters) to be less than a predetermined frequency of vibration of the powered apparatus. The mode shapes of the first and second natural frequencies of vibration impart a substantial amount of energy to the handle, and typically are the main contributors of handle vibration. Accordingly, handle vibration at those frequencies preferably are avoided. The predetermined frequency of vibration of the powered apparatus may be, for example, the frequency or frequency range of vibration of the powered apparatus under load. According to one non-limiting example, the powered apparatus is a power tool (such as a grinder) including a driven tool member (a rotating abrasive disc), the predetermined frequency of vibration under load may be, for example, the typical frequency or frequency range at which the power tool vibrates when the driven tool member is contacting and imparting force to a workpiece. In another non-limiting example, the powered apparatus is an outboard engine for a boat including a throttle handle, and the predetermined frequency of vibration under load is that frequency or frequency range at which the motor typically vibrates when the throttle of the outboard engine is at the maximum setting. In yet another example, the powered apparatus is a vehicle (such as a motorcycle or a snowmobile), and the frequency of vibration under load is the frequency or frequency range at which the vehicle typically vibrates when the vehicle commonly will be driven.

By "tuning" the beam member with first and second natural frequencies of vibration that are less than a frequency or frequency range of vibration of the powered apparatus under load, much possible vibration of the handle is avoided. Those having ordinary skill may readily ascertain a desirable predetermined frequency or range of frequency of vibration of a powered apparatus under load (for example, a frequency commonly experienced during use of the apparatus), and may readily adjust the several relevant parameters discussed above so that the beam member of a handle constructed according to the present disclosure will have first and second natural frequencies of vibration that are less than the predetermined frequency or frequency range. In this way, embodiments of a handle according to the present disclosure, such as handle **100** in FIGS. 1 through 3, dampen vibrations transmitted to the handle **100** from the apparatus. Alternatively, the first and second natural frequencies of the beam member may be tuned so as to be less than a typical frequency or frequency range of

vibration expected when the motor of the powered apparatus is running, but the apparatus is not under load. Another possible alternative is to adjust the design of the handle so that the first and second natural frequencies of the beam member are less the typical frequency or frequency range of vibration expected when the motor of the powered apparatus is running under load or is not running under load.

FIGS. 4 through 6 schematically illustrate an additional non-limiting embodiment of a vibration dampening handle according to the present disclosure. As in the handle 100 of FIGS. 1 through 3, handle 200 includes a gripping member 206 having a first end 208, an opposed second end 210, and a longitudinal axis L-L that intersects both the first end 208 and the second end 210. A generally cylindrical wall 212 defines an inner bore 214 within the gripping member 206. The inner bore 214 is defined within a portion of the gripping member 206, extends along the longitudinal axis L-L, and opens at the first end 208 of the gripping member 206. A weighted mass 216 is disposed within a cavity 217 in the second end 210 of the gripping member 206 and is retained therein by end wall 219 which, as shown in connection with embodiment 100, can be in the form of a cap that may be secured to the second end 210.

Elastic beam member 218 originates within the inner bore 214 in the vicinity of the second end 210 of the gripping member 206 and extends along the longitudinal axis L-L. A first end 220 of the beam member 218 extends beyond the first end 208 of the gripping member 206. The first end 220 of the beam member 218 includes an end region 235 that may be bonded to (for example, by a friction or some other welding bond) or unitary with reduced diameter region 236 of the beam member 218. The end element 235 of the first end 220 includes a collar portion 223 to which a fastening member 222 is secured. The fastening member 222 is adapted for securing the handle 200 to a powered apparatus. As with handle 100 of FIGS. 1 through 3, elastic beam member 218 is spaced away from and may be deflected laterally (in the directions of curved line A-A) toward wall 212. A resilient material optionally is included in all or a portion of the space between the wall 212 of the gripping member 206 and the beam member 218 to dampen deflection of the beam member 218. The end element 235 of the first end 220 of beam member 218 includes a radially projecting shoulder region 238 disposed within inner bore 214. Sufficient deflection of the beam member 218 causes the shoulder region 238 to contact the inner wall of the bore 214, thereby limiting the degree of such deflection.

As with handle 100, the weight of mass 216, the dimensions (including length and diameter or wall thickness) of the beam member 218, and the materials of construction of the beam member 218 may be selected so that first and second natural frequencies of vibration of the beam member 206 are less than the typical frequency of vibration of the powered apparatus when it is under load and/or is not under load. In this way, handle 200 will dampen vibrations transmitted to the hand of an operator

The designs of the first end 208 of the gripping member 206 and the first end 220 of the beam member 206 in handle 200 differ from the designs of the corresponding elements in handle 100. First end 220 of gripping member 206 is generally bell-shaped and includes an annular radial projection 224 having a curved surface 226 which blocks an operator's hand from contacting the portion of the powered apparatus to which the handle 200 is connected. In this respect, the projection 224 of handle 200 is similar in function to the projection 124 of handle 100, but the projection 224 also prevents

the operator's hand from making contact with the gap 230 between the beam member 218 and the wall 212.

FIG. 7 depicts one possible powered apparatus with which a handle constructed according to the present disclosure, such as handle 100, handle 200, or any of the embodiments described below, may be used. Powered small angle grinder 300 includes motor housing 306, transmission housing 308, power cord, and abrasive disc 312 that is selectively driven to rotate by engaging trigger 314. A vibration dampening handle 316 constructed according to the present disclosure, including gripping member 318, is connected to transmission housing 308. An operator may grip handle 316 and also grip region 320 of the motor housing 306. Handle 316 may be designed as generally described herein so that the first and second natural frequencies of vibration of the beam member within the handle 316 are lower than a predetermined expected frequency or frequency range of vibration of the transmission housing 308, such as the expected frequency or range of frequencies of vibration of the transmission housing 308 occurring when the disc 310 is driven to rotate and is abrading a workpiece. As an example, a typical range of frequencies of vibration of a small angle grinder of the type illustrated in FIG. 3 under load is 110 to 140 Hz. Thus, first and second natural frequencies of vibration of the beam member of the handle 316 may be sufficiently less than 110 Hz (such as, for example, around 90 Hz) so that the handle 316 will dampen vibrations. As discussed above, in an alternate means to address vibration, the handle 316 may be constructed according to the present disclosure so as to include a beam member have first and second natural frequencies of vibration that are less than an expected frequency or frequency range of vibration of the small angle grinder 300 when the motor of the device is running (i.e., the trigger 314 is engaged), but the abrasive disc 312 is not under load (i.e., the disc is not contacting a workpiece). A typical frequency of vibration of a device as depicted in FIG. 3 under these conditions is about 160 Hz. The vibration dampening capability of handle 316 can improve an operator's control of the grinder 300, and also enhance operator comfort, especially when the grinder 300 is used for extended periods.

FIGS. 8 through 10 illustrate an additional non-limiting embodiment of a vibration dampening handle constructed according to the present disclosure. Referring to FIG. 8, handle 400 is shown. FIG. 9 illustrates handle 400 sectioned through the longitudinal axis L-L of the handle 400. As suggested by FIGS. 8 and 9, longitudinal axis L-L also is an axis of symmetry about which the various exposed features are symmetric, thereby improving the ease of production and assembly. FIG. 10 shows the various parts of the handle 400 prior to assembly.

Handle 400 includes cylindrical gripping member 410 including first end 412, second end 414, and wall 416. The longitudinal axis of symmetry L-L intersects both of the first end second ends 412, 414. The first end 412 and the second end 414, respectively, include annular radial projections 420, 422, which inhibit an operator's hand from slipping off of the gripping member 410 during use of the powered apparatus. As shown in FIG. 9, wall 416, which runs the entire length of the gripping member 410, defines an inner bore 424 throughout the length of the gripping member 410. The diameter of the inner bore 424 is greater in region 425a, in the vicinity of the first end, and then steps down to region 425b having a smaller diameter in the vicinity of the second end 414. Each region 425a and 425b shares longitudinal axis L-L as an axis of symmetry. The inner bore 424 opens on the first end 414 with a diameter that is essentially equal to the widest inner diameter of the inner bore 424. In contrast, end wall 426

restricts the opening of the inner bore **424** on the second end **414** to a relatively small centrally disposed circular opening **428**. In one embodiment, the gripping member **410** is constructed of a suitable plastic using conventional injection molding techniques, although any suitable combination of materials and manufacturing techniques may be used. During assembly of handle **400**, cylindrically shaped mass **430** is inserted in the inner bore **424** through the first end **414** and is slid down to be positioned at the second end **414**. The outer diameter of region **432a** of mass **430** closely approximates the diameter of region **425b** and closely seats within region **425b**, where it is prevented from exiting second end **414** by end wall **426**. Mass **430** also includes a projecting region **432b** of smaller diameter than region **432a**. Mass **430** may be composed of any material of suitable density such as, for example, a metallic material, a ceramic, or a dense plastic.

Beam member **440** of handle **400** includes first end **442**, second end **444**, and reduced-diameter region **446**, and is symmetric about longitudinal axis L-L in assembled handle **400**. As shown in FIGS. **9** and **10**, second end **444** has an outer diameter closely approximating the inner diameter of region **425a**. Second end **444** is generally bell-shaped and includes a cylindrical wall **448** defining a cavity **450** shaped so as to substantially match the outer contour of region **432b** of mass **430**. Cylindrical wall **448** includes an annular projecting lip **452** that is received in an annular channel **454** formed on the inner surface of wall **416** of the gripping member **410** at the end of region **425a**. To retain mass **430** and second end **444** of the beam member **440** within the inner bore **424**, mass **430** is first disposed within region **425b** of the gripping member **410** and then second end **444** is slid into the inner bore **424** until lip **452** is snap fit into annular channel **454**. Mass **430** is thereby secured in region **425b**, and region **432b** is securely retained in cavity **450**. It will be understood that given the need to allow for slight elastic compression of wall **448** to accomplish the snap fit mating into channel **454**, it may be necessary to provide one or more gaps or notched regions in cylindrical wall **448**.

Again referring to FIGS. **9** and **10**, an inner cylindrical cavity **457** is provided in beam member **440** in order, for example, to reduce weight and materials costs associated with the handle **400**, and to improve the ability to manufacture the handle **400**. First end **442** of beam member **440** includes annular radial projection **458** and cylindrical collar **460**. Referring to FIG. **10**, fastening member **462** is retained in a bore in the first end **442** and extends from collar **460**. The collar **460** and the fastening member **462**, which may be, for example, the threaded member shown in FIGS. **8** through **10**, are secured within a bore in a housing of the powered apparatus to connect the handle **400** to the apparatus. Projection **458**, which is adjacent the first end **412** of the gripping member **410** when the parts are assembled, acts to block an operator's hand from contacting the apparatus housing to which the handle **400** is connected during operation of the apparatus. Region **446** of beam member **440** is of reduced diameter relative to second end **444** and is spaced apart along its entire length from wall **416**. As shown in FIG. **9**, annular shoulder **464** of first end **442** opposes and is spaced apart from wall **416**, and the remainder of first end **442** extends beyond the gripping member **410** when beam member **440** is secured within the inner bore **424** of the gripping member **410**. Beam member is constructed of a material having elastic properties allowing it to be elastically deflected relative to the gripping member **410**. As will be understood from FIG. **9**, the range of deflection of the beam member **440** relative to the gripping

member **410**, indicated by the curved arrow A-A, is limited by the width of the gap provided between shoulder **464** and the wall **416**.

Beam member **440** is constructed of a suitable elastic material such as, for example, a plastic having desirable stiffness properties, and is manufactured using conventional techniques such as, for example, blow or injection molding. As discussed above in connection with the embodiments of the handles illustrated in FIG. **1** through **6**, the weight of mass **430** and the dimensions and material of construction of the beam member **440** may be selected so that the first and second natural frequencies of vibration of the beam member are less than a frequency of vibration of the powered apparatus commonly occurring when the powered apparatus is under load. In this way, the degree of vibration to which the hand of an operator gripping the handle **400** is subjected is reduced, improving operator control and comfort. In certain embodiments of handle **400**, the parts may be designed so that the first and second natural frequencies of vibration of the beam member **440** are less than a frequency of vibration of the powered apparatus commonly occurring when the powered apparatus is not under load, which dampens vibration of the handle when the powered apparatus is in an idling state. The limited number of parts included in handle **400**, and the simple "slide and snap" method of assembling the parts, provide for ease of manufacture.

Yet an additional non-limiting embodiment of a vibration dampening handle according to the present disclosure is shown in FIGS. **11** through **13**. Handle **500** includes gripping member **510** having a first end **512**, a cylindrical side wall **514**, an end wall **516**, and a longitudinal axis L-L about which the gripping member **510** is symmetric. Wall **514** defines an inner bore **520** running the length of the gripping member **510**. Inner bore **520** opens onto first end **512** and also opens onto second end **515** through circular opening **522**, which is bounded by end wall **516**. Plastic or rubber coating member **521** is provided about the outer surface of the gripping member **510** to reduce slipping and improve comfort for an operator's hand gripping the handle **500**. The coating extends to the terminus of second end **515** of the gripping member **510**, but is spaced a distance away from the terminus of first end **512**, leaving an end region of the exterior of wall **516** uncovered by coating member **521**. Coating member **521** may be applied using traditional manufacturing techniques. For example, as suggested by the assembly view of FIG. **13**, coating member **521** may be in the form of an elastic sleeve that is slipped onto and retained by its shape and elastic properties about the gripping member **510**.

Similar to handle **400**, handle **500** further includes mass **530** including a first region **532a** and a smaller diameter second region **532b**. Mass **530** is retained within second end **515** of the gripping member **510** in a manner substantially the same as with handle **500**. More specifically, handle **500** also includes beam member **540** having a first end **542**, an opposed second end **544** and a reduced diameter region **546** intermediate the first and second regions **542**, **544**. As suggested in FIG. **12**, beam member **540** is hollow through its length and is generally symmetric about longitudinal L-L when assembled into handle **500**. Second end **544** is generally bell-shaped and includes a cylindrical wall **548** defining a cylindrical cavity **550** having dimensions that will accept the second region **532b** of the mass **530**. The terminus of cylindrical wall **548** includes a radially projecting lip **552** that securely snap-fits into an annular groove **554** formed on the inner surface of wall **514** of the gripping member **510**. Similar to handle **400**, wall **548** of the second end **544** may be notched or otherwise modified in form to allow suitable elastic compression of the

13

second end 544 when snap fitting flange 552 into groove 554. As shown in FIG. 12, when assembled with flange 552 seated in groove 554, the beam member 540 is securely retained within the inner bore 520 of the gripping member 510, and also securely retains the mass 530 within the second end 515 of the gripping member.

The portion of the reduced diameter region 546 disposed with the inner bore 520 is spaced away from the wall 516. Given that the beam member 540 is securely attached to the gripping member 510 as just described, and further given that the beam member 540 is constructed from a suitably elastic material such as, for example, a plastic having suitable stiffness properties, it will be understood that beam member 540 may be laterally deflected over a range of motion in all radial directions relative to the gripping member 510. This is suggested in FIG. 12 by line A-A. Annular shoulder 560 projects from region 546 and opposes, but is spaced apart from, the terminus of wall 514 at the first end 512 of the gripping member 510. The gap between wall 514 and shoulder 560 defines a limit of possible lateral deflection of the beam member 540 and prevents over-deflection of the beam member 540. Resilient material such as, for example, plastic or rubber, may be disposed in all or a region of the space between the inner surface of wall 516 and the outer surface of the region 546 of the beam member 540 to dampen deflection of the beam member 540 relative to the gripping member 510. The reduced diameter region 546 of the beam member 540 continues beyond the first end 512 of the gripping member and flares out to form first end 542. First end 542 includes collar 562 defining a bore into which fastener 564 is secured. The collar 562 and the fastener 564 may be secured in a bore in a housing or other element of the powered apparatus to secure the handle 500 to the powered apparatus.

Hollow flange member 570 includes first end 572 including annular radial projection 573, and second end 574. The inner diameter 575 of the flange member 570 is secured about the outer diameter 576 of the first end 542 of the beam member 540 so that the terminus of the second end 574 opposed but is slightly spaced apart from the terminus of side wall 514 of the gripping member 510. It will be understood and is shown in FIG. 12 that a slight gap 578 exists between the flange member 570 and the gripping member 510. To prevent an operator's hand from contacting the gap 578, a sleeve member 580 having an inner shape conforming to a region of the outer surface of the flange member 570 overlays the gap 578 and extends to cover a margin of the outer surface of the wall 514 that is not covered by coating member 521. The flange member 570 and the sleeve member 580 may be constructed of any suitable materials, using any suitable conventional manufacturing techniques. For example, the members may be manufactured of a suitable resilient plastic using injection molding or blow molding techniques.

According to an aspect of the present disclosure, the weight of mass 530 and the dimensions and material of construction of the beam member 540 may be selected so that the first and second natural frequencies of vibration of the beam member 540 are less than a frequency or range of frequencies of vibration of the powered apparatus commonly occurring when the powered apparatus is or is not under load. In this way, the degree of vibration to which the hand of an operator gripping the handle 500 is subjected is reduced, improving operator control and comfort.

Additional possible embodiments of a vibration dampening handle for a powered apparatus are illustrated in the FIGS. 14 through 25, as follows. In each of these embodiments, to dampen vibrations, the weight of the mass and the dimensions and materials of the beam member of the handle may be

14

pre-selected so that at least the first and second standing frequencies of vibration of the beam member are less than a predetermined typical expected frequency or range of frequencies of vibration of the particular powered apparatus to which the handle would be connected.

FIGS. 14 through 16 are different views depicting one possible embodiment of a vibration dampening handle 600 according to the present disclosure. With reference to FIGS. 14 through 16, handle 600 includes generally cylindrical gripping member 610 having first end 612, second end 614, and longitudinal axis L-L, about which the gripping member 610 is symmetric. Beam member 620 includes first end 622 (to which is attached a fastening member 623), second end 624, and reduced diameter region 626 intermediate the first end 622 and the second end 624. Mass 630 is retained at the second end 614 of the gripping member 610 by a snap fit arrangement connecting the beam member 620 to the gripping member 610 by snap hooks 625 on second end 624. This snap fit arrangement is similar to the embodiments of FIGS. 8 through 13. As best shown in FIGS. 14 and 15, funnel-shaped shoulder member 640, composed, for example, of a resilient plastic or rubber material, is secured to a surface of the beam member 620. As shown in FIG. 15, shoulder member 640 overlaps the terminus of the wall 616 of the gripping member 610 in a region 641, thereby avoiding a gap between the shoulder member 640 and the gripping member 610. As shown by comparing the handle 500 of FIGS. 11 through 13 to handle 600 of FIGS. 14 through 16, the design of the first end 622 of the beam member 620 of handle 600 that results from securing the shoulder member 640 to the first end 622 is similar to the design of the first end 542 of the beam member 540 of handle 500 that results from attaching the flange member 570 and the coating member 580 to the first end 542.

Advantages of the design of handle 600 of FIGS. 14 through 16 relative to the design of handle 500 of FIGS. 11 through 13 include the use of three basic parts (elements 620, 623, and 640) in handle 600, versus the use of four basic parts (elements 540, 564, 570, and 580) in handle 500 to provide the assemblage of elements that may be deflected relative to the gripping member. The shoulder member 640 of handle 600, however, must be, for example, adhesively secured or molded into the first end 622 of the beam member 620. This contrasts with the assembly of flange member 570 and coating member 580 of handle 500, which may be designed to snap or press fit about the surface of the elements they overlies. Thus, handle 500 may provide an advantage in terms of ease of manufacture relative to handle 600. Also, beam member 620 of handle 600 lacks any distinct structure limiting the degree of lateral deflection of the beam member 620 relative to the gripping member 610. Instead, in theory the beam member 620 may be laterally deflected until the periphery of the region 626 of the beam member 620 contacts the first end 614 of the gripping member 610. In contrast, annular shoulder 560 of the beam member 540 of handle 500 may be designed to limit lateral deflection of the beam member 540 to a degree that can be safely tolerated by the mechanical characteristics of the beam member 540.

Referring to the additional embodiment shown in cross-section in FIGS. 17 through 19, vibration dampening handle 700 includes four parts of relatively simple geometries. As shown in the cross-sectional view of FIG. 18 and the assembly view of FIG. 19, generally cylindrical gripping member 710 includes first end 712, second end 714, wall 716, and longitudinal axis of symmetry L-L. The wall 716 defines a generally cylindrical inner bore 717. First end 712 is flared into radial projection 719, which helps to prevent an operator's hand from slipping off of the gripping member 710.

Beam member 720 includes first end 722, opposed second end 724, and reduced diameter section 726 intermediate the first and second ends 722, 724. As indicated in FIG. 18, the second end 724 of beam member 720 includes snap hooks 725 that snap fit into a groove on the inner surface of the gripping member 710, thereby securing the beam member 720 to the gripping member 710 and securely retaining mass 730 within the second end 714 of the gripping member. As best shown in FIG. 18, so as to more securely seat mass 730 within the second end 714 of the gripping member 710, mass 730 includes cylindrical projection 731 that is secured within a similarly shaped cavity within the second end 724 of the beam member 720.

FIGS. 20 through 22 illustrate yet another possible non-limiting embodiment according to the present disclosure. FIG. 21 is a schematic cross-sectional view of vibration dampening handle 800 shown in plan view in FIG. 20, taken through longitudinal axis L-L. FIG. 22 is an assembly view showing several component parts of handle 800. As in certain of the embodiments discussed above, handle 800 includes a generally cylindrical gripping member 810 and a beam member 820 that are an integral part. As shown in FIG. 21, the second end 824 of the beam member 820 is integral with the gripping member 810.

As best shown in FIG. 21, the beam member 820 extends along longitudinal axis L-L through the inner bore 816 provided in gripping member 810 and beyond the first end 812 of the gripping member 810. Mass 830 is disposed in a generally cylindrical cavity provided in the second end 814 of the gripping member 810. The mass 830 is retained in the cavity by an end region 832 on second end 814. An end element 835 is secured the first end 822 of the beam member 820 by suitably friction fitting, bonding, or otherwise securing cylindrical stem 836 of the end element 835 within a bore 837 defined by beam member 820. A fastening member 828 is secured to a collar portion 829 of the end element 835.

The first end 812 of the gripping member and the annular skirt region 838 of the end element 835 are configured so that when the end element 835 is secured to the beam member 820, a narrow gap 840 exists between the end element 835 and the first end 812, allowing some deflection of the end element 835 relative to the gripping member 810 in the direction A-A in response to vibration of the apparatus to which handle 800 is connected. To prevent an operator's hand from contacting the gap 840, an annular slot is provided around the perimeter of the handle 800 at the junction of the end element 835 and the gripping member 810. An elastic band 845 is disposed in the slot and is retained therein by the elastic properties of the material from which the band 845 is constructed.

FIG. 23 illustrates a cross section of yet another embodiment of a vibration dampening handle according to the present disclosure. Handle 900 of FIG. 23 is in many respects identical to handle 500 shown in FIGS. 11 through 13. Handle 900 includes gripping member 910 having a first end 912, a peripheral wall 914, and a longitudinal axis L-L. Wall 914 defines an inner bore 920 through the length of the gripping member 910, which opens onto first end 912 and second end 915 of the gripping member 910. Resilient material layer or coating 921 is provided about the outer surface of the gripping member 910 to reduce slipping and improve operator comfort. The coating extends to the terminus of second end 915 of the gripping member 910, but is spaced a distance away from the terminus of first end 912, thereby leaving an end region of the exterior of wall 914 uncovered by coating 921.

Beam member 940 includes a first end 942, an opposed second end 944, and a reduced diameter region 946 intermediate the first and second regions 942, 944. As shown in FIG.

23, beam member 940 of handle 900 is hollow through its length and is generally symmetric about longitudinal axis L-L when assembled into handle 900. Second end 944 is generally bell-shaped and includes a cylindrical wall 948 defining a cylindrical cavity. The terminus of cylindrical wall 948 includes a radially projecting lip 952 that securely snap-fits into an annular groove 954 formed on the inner surface of wall 914 of the gripping member 910. Wall 948 may be constructed so as to allow for suitable elastic compression of the second end 944 when snap fitting lip 952 into groove 954. As suggested in FIG. 23, the snap fit arrangement securely retains beam member 940 within inner bore 920.

Handle 900 includes a mass 930 having a first region 932a, a second region 932b, and a third region 932c. As shown in FIG. 23, mass 930 is disposed within second end 915 of the gripping member 910 so that second region 932b of the mass 930 is received within the cavity formed by cylindrical wall 948. A cap member 950 includes flange 952 that is securely received in a snap fit manner within an annular groove formed on the inner periphery of wall 914 near the terminus of the second end 915 of the gripping member 910. The mass 930 is inserted into the gripping member 910 from the second end 915. The cap member 950 secures the mass 930 within the second end 915, between the cap member 950 and the beam member 940. Mass 930 is maintained in the second end 915 with third region 932c flush with the outer end 952 of cap 950 to provide wear resistance.

The portion of reduced diameter region 946 of beam member 940 disposed with the inner bore 920 is spaced away from the wall 914. Given that the beam member 940 is securely attached to the gripping member 910 as described above, and further given that the beam member 940 is constructed from a suitably elastic material, the beam member 940 may be laterally deflected over a range of motion in all radial directions relative to the gripping member 910, as suggested by line A-A. Annular shoulder 960 projects from region 946 and opposes, but is spaced apart from, the terminus of wall 914 at the first end 912 of the gripping member 910. The gap between wall 914 and shoulder 960 defines a limit of possible lateral deflection of the beam member 940 and prevents over-deflection of the beam member 940. Resilient material, such as described above, may be disposed in all or a region of the space between the inner surface of wall 914 and the outer surface of the region 946 of the beam member 940 to dampen deflection of the beam member 940.

Reduced diameter region 946 of the beam member 940 continues beyond the first end 912 of the gripping member forms first end 942. First end 942 includes collar 962 to which fastener 964 is secured. The collar 962 and the fastener 964 may be used to secure the handle 900 to a powered apparatus. Flange member 970 includes an inner diameter 975 that is secured about the outer diameter 976 of the first end 942 of the beam member 940 so that the a terminus of the flange member 970 opposes but is slightly spaced apart from the terminus of side wall 914 of the gripping member 910. A slight gap 978 exists between the flange member 970 and the gripping member 910. To prevent an operator's hand from contacting the gap 978, a sleeve member 980 having an inner shape conforming to a region of the outer surface of the flange member 970 overlays the gap 978 and extends to cover a margin of the outer surface of the wall 914 that is not covered by coating member 921.

Although the foregoing description has necessarily presented a limited number of embodiments of the invention, those of ordinary skill in the relevant art will appreciate that various changes in the compositions and other details of the examples that have been described and illustrated herein in

17

order to explain the nature of the invention may be made by those skilled in the art, and all such modifications will remain within the principle and scope of the invention as expressed herein and in the appended claims. It will also be appreciated by those skilled in the art that changes could be made to the embodiments above without departing from the broad inventive concept thereof. It is understood, therefore, that this invention is not limited to the particular embodiments disclosed, but it is intended to cover modifications that are within the principle and scope of the invention, as defined by the claims.

We claim:

1. A vibration dampening handle for a powered apparatus, the handle comprising:

an elongate gripping member including a first end, a second end opposite the first end, a longitudinal axis extending through the first end and the second end, and a wall defining an inner bore and having an inner surface, the inner bore extending along the longitudinal axis at least partially through the gripping member and opening on at least the first end;

a mass disposed at the second end of the gripping member; and

an elongate elastic beam member one of fixedly attached to and integral with the gripping member, wherein at least a portion of the beam member is immovable relative to the gripping member, the beam member extending along a region of the longitudinal axis and including a portion within the inner bore and spaced apart from the inner surface, the beam member further including a first end extending beyond the first end of the gripping member and including a fastening member adapted to connect the handle to the powered apparatus, the beam member further including a second end which is one of fixedly attached to and integral with the gripping member, wherein the first end of the gripping member is cantilevered with respect to the second end of the beam member and is movable relative to the first end of the beam member.

2. The vibration dampening handle of claim **1**, wherein the mass is disposed within the inner bore at the second end of the gripping member.

3. The vibration dampening handle of claim **1**, wherein the second end of the beam member is fixedly mated with a region of the inner surface of the wall of the gripping member.

4. The vibration dampening handle of claim **1**, wherein the second end of the beam member is integral with the wall of the gripping member.

5. The vibration dampening handle of claim **1**, wherein the longitudinal axis is an axis of symmetry of the gripping member.

6. The vibration dampening handle of claim **1**, wherein the longitudinal axis is an axis of symmetry of the beam member.

7. The vibration dampening handle of claim **1**, wherein first and second resonance frequencies of the beam member are lower than a frequency of vibration of the powered apparatus.

8. The vibration dampening handle of claim **7**, wherein the powered apparatus is a power tool including a driven tool member, and further wherein the frequency of vibration of the powered apparatus is a frequency of vibration that occurs when driven tool member is under load.

9. The vibration dampening handle of claim **1**, wherein the powered apparatus is a power tool including a driven tool member, and wherein the weight of the mass and the material, shape, and geometry of the beam member are selected so as that the first and second resonance frequencies of the beam

18

member are less than a frequency of vibration of the powered apparatus that occurs when driven tool member is under load.

10. The vibration dampening handle of claim **1**, wherein the first end of the beam member includes an annular wall projecting toward the gripping member, an end of the annular wall closely abutting and spaced apart from an end of the wall of the gripping member, the end of the annular wall including an outer diameter that is substantially equal to an outer diameter of the end of the wall of the gripping member.

11. The vibration dampening handle of claim **1**, wherein the fastening member includes a threaded portion that may be affixed to the powered apparatus.

12. The vibration dampening handle of claim **1**, wherein the first end of the beam member includes an annular shoulder that is at least partially disposed in the inner bore and that may contact the inner surface of the wall of the gripping member when the beam member is sufficiently deflected relative to the gripping member, the shoulder thereby limiting the range of deflection of the beam member relative to the gripping member.

13. The vibration dampening handle of claim **1**, wherein the powered apparatus is a power tool comprising a driven tool member.

14. The vibration dampening handle of claim **1**, wherein the powered apparatus is selected from the group consisting of a power tool, a grinder, a drill, a polisher, a saw, an outboard motor, a powered vehicle, a motorcycle, and a snowmobile.

15. A handle for a power tool including a driven tool member, the handle capable of reducing transmitted vibration, the handle comprising:

a gripping member including an elongate portion comprising a first end, a second end opposite the first end, and a wall defining an inner bore including an inner surface, the inner bore extending along at least a portion of a longitudinal axis of the gripping member and opening on at least the first end of the gripping member;

a mass disposed at the second end of the gripping member; and

an elongate elastic beam member one of fixedly attached to or integral with the gripping member, wherein at least a portion of the beam member is stationary relative to the gripping member, the beam member extending along a region of the longitudinal axis, wherein at least a portion of the beam member is within the inner bore and spaced apart from the wall of the gripping member, at least a portion of a first end of the beam member extending beyond the first end of the gripping member and including a fastening member to connect the handle to the power tool, the beam member further including a second end which is one of fixedly attached to or integral with the gripping member, wherein the first end of the gripping member is cantilevered with respect to the second end of the beam member and is movable relative to the first end of the beam member.

16. The handle of claim **15**, wherein the mass is disposed within the inner bore at the second end of the gripping member.

17. The handle of claim **15**, wherein the second end of the beam member is one of:

integral with the wall of the gripping member;

or fixedly mated with a region of the wall of the gripping member within the inner bore.

18. The handle of claim **15**, wherein the longitudinal axis defines an axis of symmetry of at least one of the gripping member and the beam member.

19

19. The handle of claim 15, wherein first and second resonance frequencies of the beam member are lower than a frequency of vibration of the power tool when the driven tool member is under load.

20. The handle of claim 15, wherein the first end of the beam member includes an annular wall projecting toward and including an end closely abutting and spaced apart from an end of the wall of the gripping member, the end of the annular wall including an outer diameter that is substantially equal to an outer diameter of the abutting end of the wall of the gripping member.

21. The handle of claim 15, wherein the fastening member includes a threaded portion that may be attached to the power tool.

22. The handle of claim 15, wherein the first end of the beam member includes an annular shoulder at least partially disposed in the inner bore and that may contact the wall of the bore when the beam member is sufficiently deflected relative to the gripping member, the shoulder thereby limiting the range of deflection of the beam member relative to the gripping member.

23. The handle of claim 15, wherein the power tool is selected from the group consisting of a grinder, a drill, a polisher, and a saw.

24. A powered apparatus including a handle manipulated by an operator of the powered apparatus, the handle adapted to dampen vibration generated by the apparatus, the handle comprising:

an elongate gripping member including a first end, a second end opposite the first end, a longitudinal axis extending through the first end and the second end, and a wall defining an inner bore and having an inner surface, the inner bore extending along the longitudinal axis at least partially through the gripping member and opening on at least the first end;

a mass disposed at the second end of the gripping member; and

an elongate elastic beam member fixedly attached to the gripping member, wherein at least a portion of the beam member is immovable relative to the gripping member, the beam member extending along a region of the longitudinal axis and including a portion within the inner bore and spaced apart from the inner surface, the beam member further including a first end extending beyond the first end of the gripping member and including a fastening member adapted to connect the handle to the

20

powered apparatus, the beam member further including a second end which is fixedly attached to the gripping member, wherein the first end of the gripping member is cantilevered with respect to the second end of the beam member and is movable relative to the first end of the beam member.

25. The powered apparatus of claim 24, wherein the powered apparatus is a power tool.

26. The powered apparatus of claim 24, wherein the powered apparatus is selected from the group consisting of a grinder, a drill, a polisher, and a saw.

27. The powered apparatus of claim 24, wherein the powered apparatus is selected from the group consisting of an outboard motor, a powered vehicle, a motorcycle, and a snowmobile.

28. A power tool including a driven tool member and a vibration dampening handle for manipulating the power tool, the handle comprising:

a gripping member including an elongate portion comprising a first end, a second end opposite the first end, and a wall defining an inner bore including an inner surface, the inner bore extending along at least a portion of a longitudinal axis of the gripping member and opening on at least the first end of the gripping member;

a mass disposed at the second end of the gripping member; and

an elongate elastic beam member one of fixedly attached to or integral with the gripping member, wherein at least a portion of the beam member is stationary relative to the gripping member, the beam member extending along a region of the longitudinal axis, wherein at least a portion of the beam member is within the inner bore and spaced apart from the wall of the gripping member, at least a portion of a first end of the beam member extending beyond the first end of the gripping member and including a fastening member to connect the handle to the power tool, the beam member further including a second end which is one of fixedly attached to or integral with the gripping member, wherein the first end of the gripping member is cantilevered with respect to the second end of the beam member and is movable relative to the first end of the beam member.

29. The power tool of claim 28, wherein the power tool is selected from the group consisting of a grinder, a drill, a polisher, and a saw.

* * * * *