



US007659621B2

(12) **United States Patent**
Rinne

(10) **Patent No.:** **US 7,659,621 B2**
(45) **Date of Patent:** **Feb. 9, 2010**

(54) **SOLDER STRUCTURES FOR OUT OF PLANE CONNECTIONS**

3,458,925 A 8/1969 Napier et al.

(75) Inventor: **Glenn A. Rinne**, Apex, NC (US)

(Continued)

(73) Assignee: **Unitive International Limited**, Curacao (NL)

FOREIGN PATENT DOCUMENTS

DE 42 05 029 C 2/1993

(*) Notice: Subject to any disclaimer, the term of this patent is extended or adjusted under 35 U.S.C. 154(b) by 347 days.

(Continued)

OTHER PUBLICATIONS

(21) Appl. No.: **11/362,964**

Adema et al., *Flip Chip Technology: A Method for Providing Known Good Die with High Density Interconnections*, MCM '94 Proceedings, pp. 41-49, (1994).

(22) Filed: **Feb. 27, 2006**

(65) **Prior Publication Data**

(Continued)

US 2006/0138675 A1 Jun. 29, 2006

Related U.S. Application Data

Primary Examiner—Tuan N. Quach
(74) Attorney, Agent, or Firm—Myers Bigel Sibley & Sajovec, P.A.

(62) Division of application No. 10/965,640, filed on Oct. 13, 2004, now Pat. No. 7,049,216.

(60) Provisional application No. 60/510,819, filed on Oct. 14, 2003.

(51) **Int. Cl.**
H01L 23/48 (2006.01)

(52) **U.S. Cl.** 257/737; 257/779; 257/E23.015; 257/E23.037

(58) **Field of Classification Search** 257/737, 257/739, E23.015, E23.002, E23.037, 779
See application file for complete search history.

(57) **ABSTRACT**

Methods of forming a solder structure may include providing a wafer including a plurality of die therein, and a solder wettable pad may be formed on one of the die adjacent an edge of the die. The solder wettable pad may have a length parallel to the edge of the die and a width perpendicular to the edge of the die wherein the length parallel to the edge of the die is greater than the width perpendicular to the edge of the die. A solder bump may be plated on the solder wettable pad, and the die may be separated from the wafer along the edge of the die after plating the solder bump on the solder wettable pad. Moreover, the solder bump may be reflowed on the solder wettable pad so that the solder structure extends laterally from the solder wettable pad beyond the edge of the die after separating the die from the wafer. Related structures are also discussed.

(56) **References Cited**

U.S. PATENT DOCUMENTS

3,105,869 A 10/1963 Branch et al.
3,244,947 A 4/1966 Slater
3,259,814 A 7/1966 Green
3,274,458 A 9/1966 Boyer et al.
3,316,465 A 4/1967 von Bermuth et al.

41 Claims, 10 Drawing Sheets

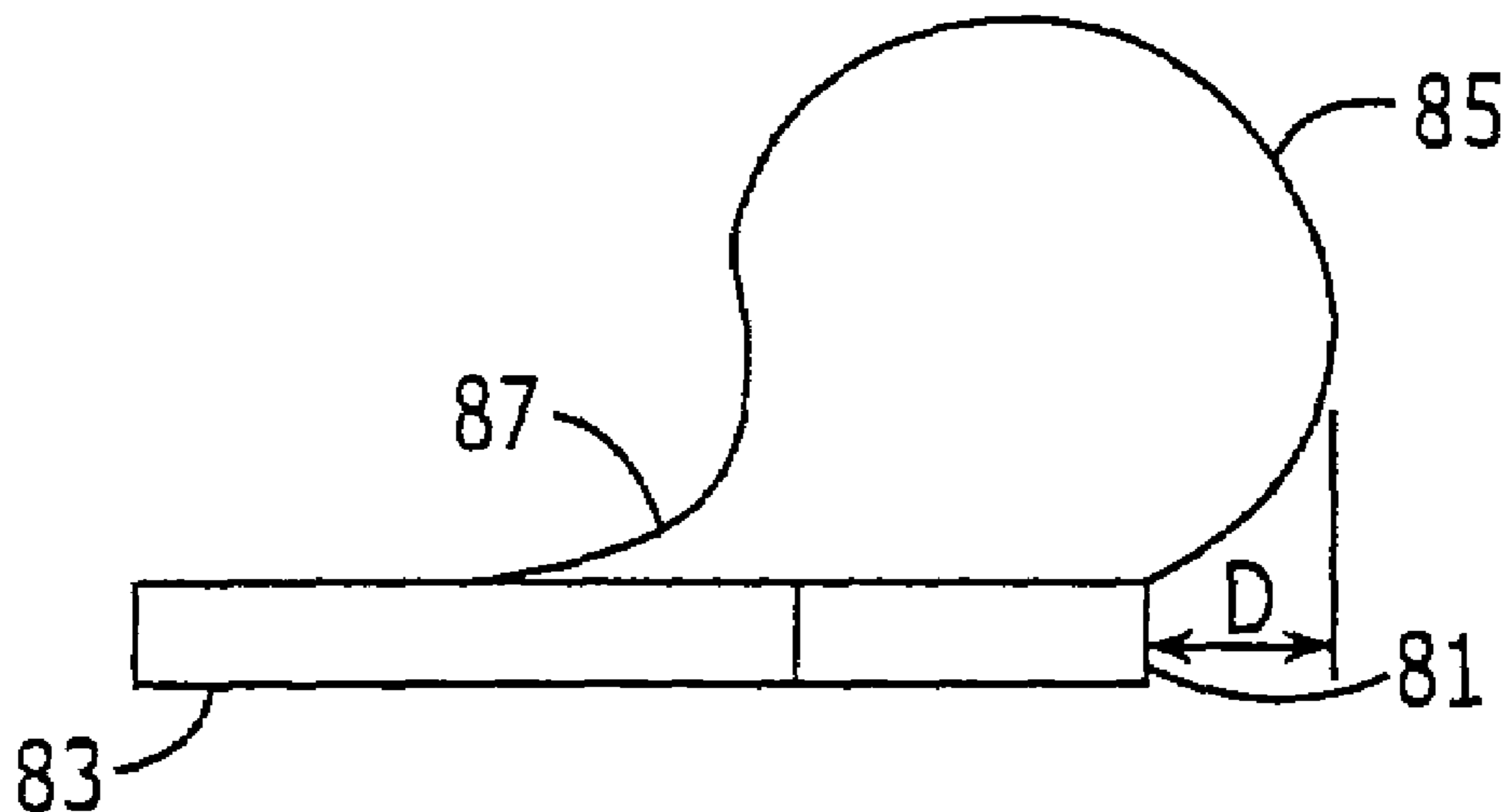

U.S. PATENT DOCUMENTS

3,461,357 A 8/1969 Mutter et al.
 3,489,965 A 1/1970 Helsdon
 3,501,681 A 3/1970 Weir
 3,663,184 A 5/1972 Wood et al.
 3,760,238 A 9/1973 Hamer et al.
 3,770,874 A 11/1973 Krieger et al.
 3,871,014 A 3/1975 King et al.
 3,871,015 A 3/1975 Lin et al.
 3,897,871 A 8/1975 Zimmbauer
 3,916,080 A 10/1975 Wakamatsu
 3,942,187 A 3/1976 Gelsing et al.
 3,959,577 A 5/1976 Frink
 3,986,255 A 10/1976 Mandal
 3,993,123 A 11/1976 Chu et al.
 4,074,342 A 2/1978 Honn et al.
 4,113,578 A 9/1978 Del Monte
 4,113,587 A 9/1978 Chikamori
 4,168,480 A 9/1979 De Lucia
 4,244,002 A 1/1981 Sato et al.
 4,257,905 A 3/1981 Christophorou et al.
 4,266,282 A 5/1981 Henle et al.
 4,273,859 A 6/1981 Mones et al.
 4,382,517 A 5/1983 Welsch
 4,449,580 A 5/1984 Reisman et al.
 4,473,263 A 9/1984 Sunstein
 4,511,873 A 4/1985 Baier et al.
 4,532,576 A 7/1985 Reimer
 4,545,610 A 10/1985 Lakritz et al.
 4,563,697 A 1/1986 Miura
 4,565,901 A 1/1986 Hirooka et al.
 4,657,146 A 4/1987 Walters
 4,661,375 A 4/1987 Thomas
 4,840,302 A 6/1989 Gardner et al.
 4,855,809 A 8/1989 Malhi et al.
 4,878,611 A 11/1989 Lo Vasco et al.
 4,897,508 A 1/1990 Mahulikar et al.
 4,927,505 A 5/1990 Sharma et al.
 4,948,754 A 8/1990 Kondo et al.
 4,950,623 A 8/1990 Dishon
 4,962,058 A 10/1990 Cronin et al.
 5,019,943 A 5/1991 Fassbender
 5,022,580 A 6/1991 Pedder
 5,024,372 A 6/1991 Altman et al.
 5,046,161 A 9/1991 Takada
 5,048,747 A 9/1991 Clark et al.
 5,113,314 A 5/1992 Wheeler et al.
 5,135,155 A 8/1992 Kang et al.
 5,160,409 A 11/1992 Moore et al.
 5,162,257 A 11/1992 Yung
 5,194,137 A 3/1993 Moore et al.
 5,227,664 A 7/1993 Toshio
 5,234,149 A 8/1993 Katz et al.
 5,239,447 A 8/1993 Cotues et al.
 5,240,881 A 8/1993 Cayetano et al.
 5,250,843 A 10/1993 Eichelberger
 5,289,925 A 3/1994 Newmark
 5,293,006 A 3/1994 Yung
 5,325,265 A 6/1994 Turlik et al.
 5,327,013 A 7/1994 Moore et al.
 5,327,327 A 7/1994 Frew et al.
 5,335,795 A 8/1994 Chizen
 5,347,428 A 9/1994 Carson et al.
 5,354,711 A 10/1994 Heitzmann et al.
 5,406,701 A 4/1995 Pepe et al.
 5,424,920 A 6/1995 Miyake
 5,432,729 A 7/1995 Carson et al.
 5,453,582 A 9/1995 Amano et al.
 5,475,280 A 12/1995 Jones et al.
 5,492,235 A 2/1996 Crafts et al.
 5,547,740 A 8/1996 Higdon et al.
 5,557,502 A 9/1996 Bannerjee et al.

5,616,962 A 4/1997 Ishikawa et al.
 5,627,396 A 5/1997 James et al.
 5,680,296 A 10/1997 Hileman et al.
 5,736,456 A 4/1998 Akram
 5,739,053 A 4/1998 Kawakita et al.
 5,744,382 A 4/1998 Kitayama et al.
 5,751,556 A 5/1998 Butler et al.
 5,773,359 A 6/1998 Mitchell et al.
 5,793,116 A 8/1998 Rinne et al.
 5,812,378 A 9/1998 Fielstad et al.
 5,851,911 A 12/1998 Farnworth
 5,898,574 A 4/1999 Tan et al.
 5,923,539 A 7/1999 Matsui et al.
 5,963,793 A 10/1999 Rinne et al.
 5,990,472 A 11/1999 Rinne
 6,134,120 A 10/2000 Baldwin
 6,167,615 B1* 1/2001 Ma et al. 29/840
 6,169,325 B1 1/2001 Azuma
 6,201,305 B1 3/2001 Darveaux et al.
 6,268,655 B1 7/2001 Farnworth et al.
 6,310,390 B1 10/2001 Moden
 6,388,203 B1 5/2002 Rinne et al.
 6,392,163 B1 5/2002 Rinne et al.
 6,404,064 B1 6/2002 Tsai et al.
 6,414,374 B2 7/2002 Farnworth et al.
 6,418,033 B1 7/2002 Rinne
 6,539,624 B1 4/2003 Kung et al.
 6,825,547 B2 11/2004 Farnworth et al.
 6,900,079 B2 5/2005 Kinsman et al.
 2002/0020551 A1 2/2002 Rinne et al.
 2003/0102560 A1 6/2003 Kim et al.
 2004/0187296 A1* 9/2004 Cowles et al. 29/603.07

FOREIGN PATENT DOCUMENTS

DE 43 23 799 A1 1/1994
 EP 0 609 062 A1 8/1994
 EP 0 736 972 A1 10/1996
 EP 0 918 355 A2 5/1999
 EP 1 041 617 A1 10/2000
 FR 2 406 893 10/1978
 FR 2 688 628 9/1993
 FR 2 705 832 12/1994
 GB 1288564 9/1972
 GB 2062 963 5/1981
 GB 2 194 387 3/1988
 JP 55-111127 8/1980
 JP 57-73952 5/1982
 JP 57-197838 12/1982
 JP 59-154041 9/1984
 JP 6-116552 1/1986
 JP 63099558 4/1988
 JP 63-222445 9/1988
 JP 4-150033 5/1992
 JP 07066207 1/1994
 WO WO 93/02831 2/1993
 WO WO 93/22475 11/1993
 WO WO 96/31905 10/1996
 WO WO 98/06118 2/1998

OTHER PUBLICATIONS

Datta et al., *Electrochemical Fabrication of Mechanically Robust PbSn C4 Interconnections*, J. Electrochem. Soc., vol. 142, No. 11, The Electrochemical Society, Inc., Nov. 1995, pp. 3779-3785.
 Drake et al; *An Electrostatically Actuated Micro-Relay*, Transducers '95, Eurosensors IX, The 8th International Conference on Solid-State Sensors and Actuators, and Eurosensors IX, pp. 380-383, (1995).
 Guckel et al., *Electromagnetic Linear Actuators with Inductive Position Sensing for Micro Relay, Micro Valve and Precision Positioning Applications*, Transducers '95, Eurosensors IX, The 8th International Conference on Solid-State Sensors and Actuators, and Eurosensors IX, pp. 324-327, (1995).

Hashimoto et al; *Thermally Controlled Magnetization Microrelay*, Transducers '95, Eurosensors IX, The 8th International Conference on Solid-State Sensors and Actuators, and Eurosensors IX, pp. 361-364, (1995).

Hirsch, *Tin-Lead, Lead and Tin Plating*, Metal Finishing, Guidebook Directory 1987, 55th Guidebook-Directory Issue 1987, Mid Jan. 1987, vol. 85, No. 1A, ISSN 0026-0576, pp. 280-284.

Hosaka et al; *Electromagnetic Microrelays: Concepts and Fundamental Characteristics*, Sensors and Actuators A, 40 (1994), pp. 41-47.

Howell et al; "Area Array Solder Interconnection Technology for the Three-Dimensional Silicon Cube" Proceedings of the 1995 45th Electronic Components & Technology Conference, pp. 1174-1178, (1995).

Inaba et al; *Solder Bump Formation Using Electroless Plating and Ultrasonic Soldering*, IEEE Transactions On Components, Hybrids, and Manufacturing Technology, vol. 13, No. 1, Mar. 1990, pp. 119-123.

International Search Report and Written Opinion of the International Searching Authority for International patent application No. PCT/US2004/033946 mailed on Jul. 4, 2005.

Knüppel, *Rugged Design for Reliable Switching: Micro a Relay Sets New Automotive Standards*, Components XXIX (1994), No. 4, pp. 30-32.

Lineback, "3D IC Packaging Moves Closer to Commercial Use", Electronic World News, May 21, 1990, p. 15.

Multimedia Card Association, www.mmca.org, (2004).

PCB Assembly, *Electronic Packaging & Production*, vol. 35, No. 1, p. 40 (Jan. 1995).

SanDisk Corporation, SanDisk Flash Data Storage, San Disk Compact Flash™ and MultiMedia Card: Small Form Factor Solutions, 1999.

Specification Sheet, *NaiS, Ultra Low Profile 2 Amp-Polarized Relay*, TK-Relays, (2004).

* cited by examiner

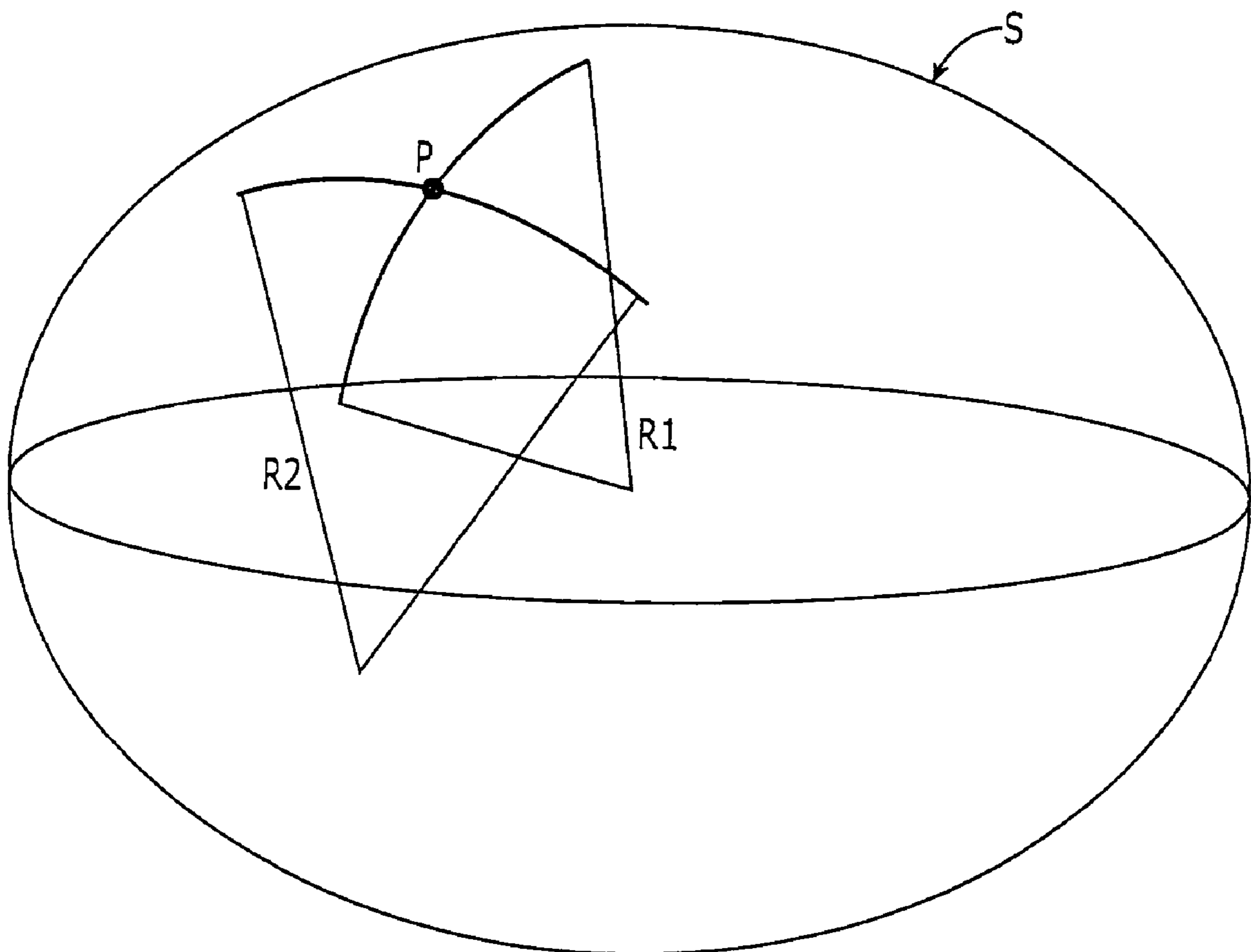

Surface Curvature at a Point

FIGURE 1

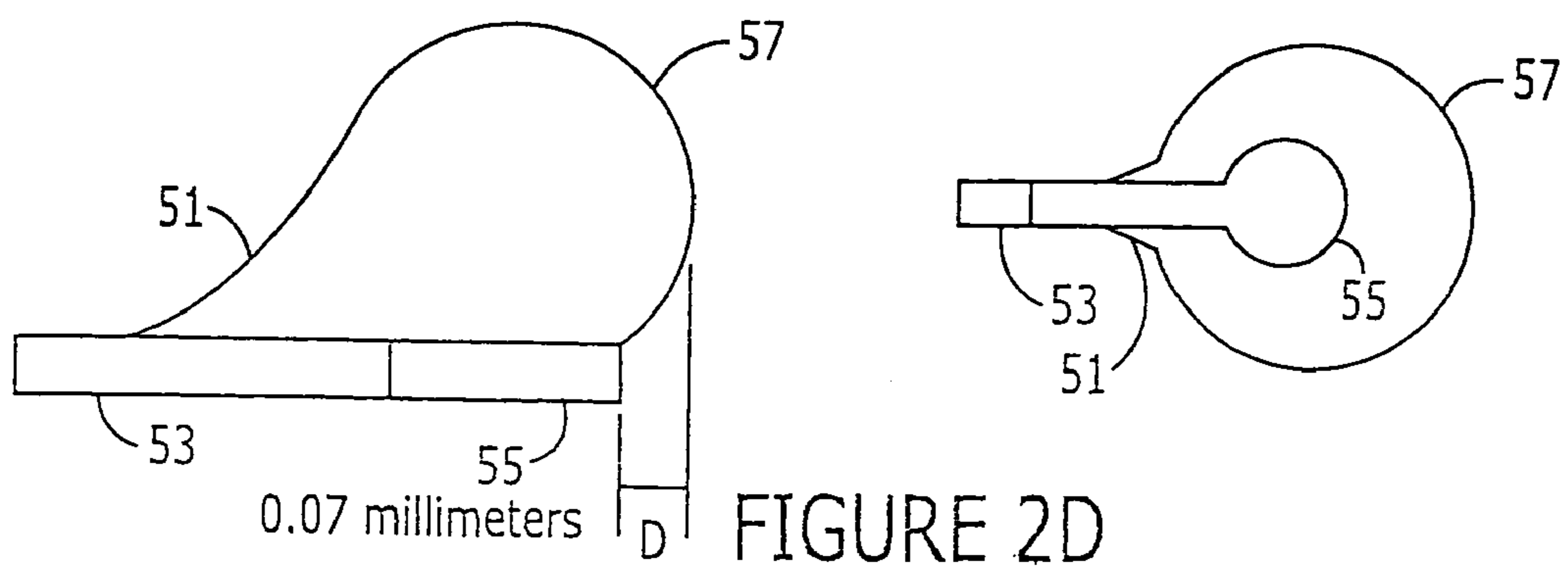
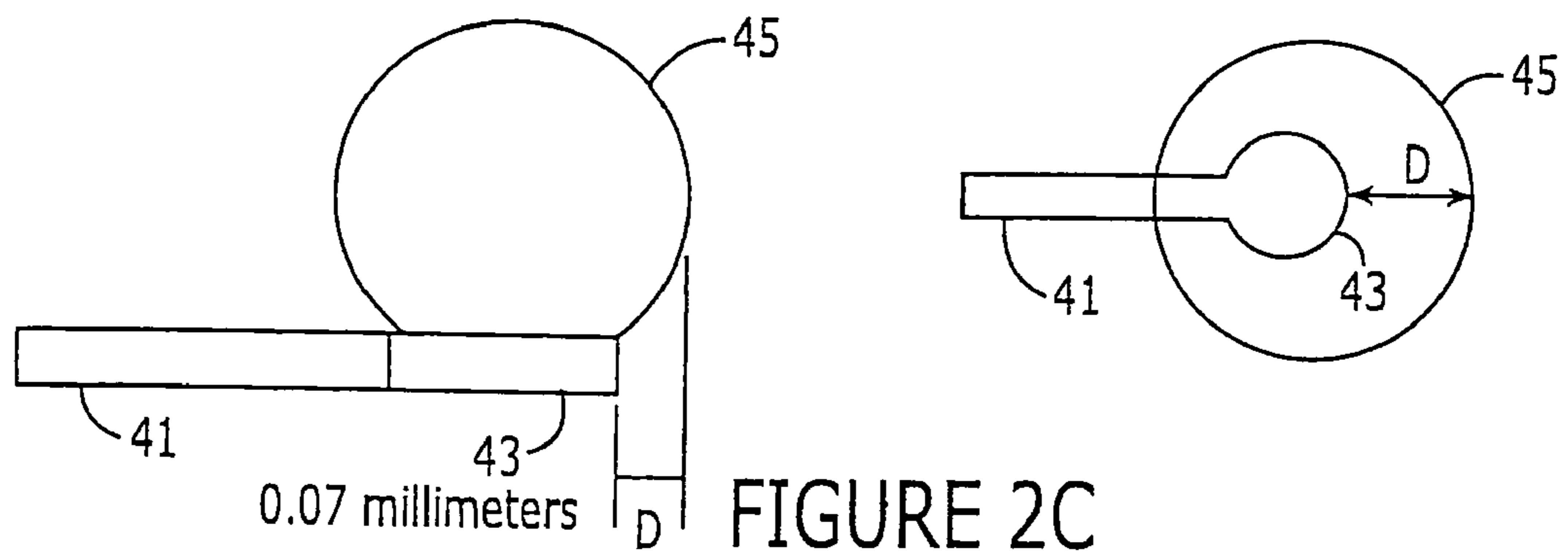
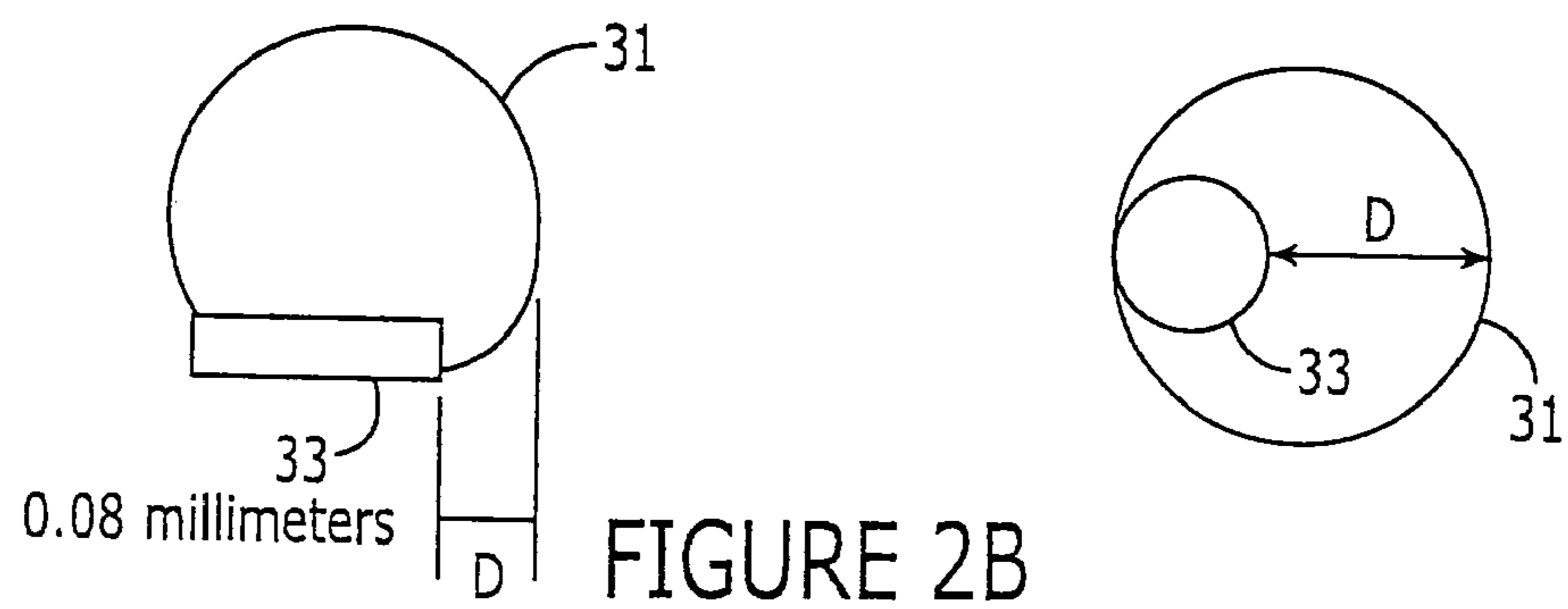
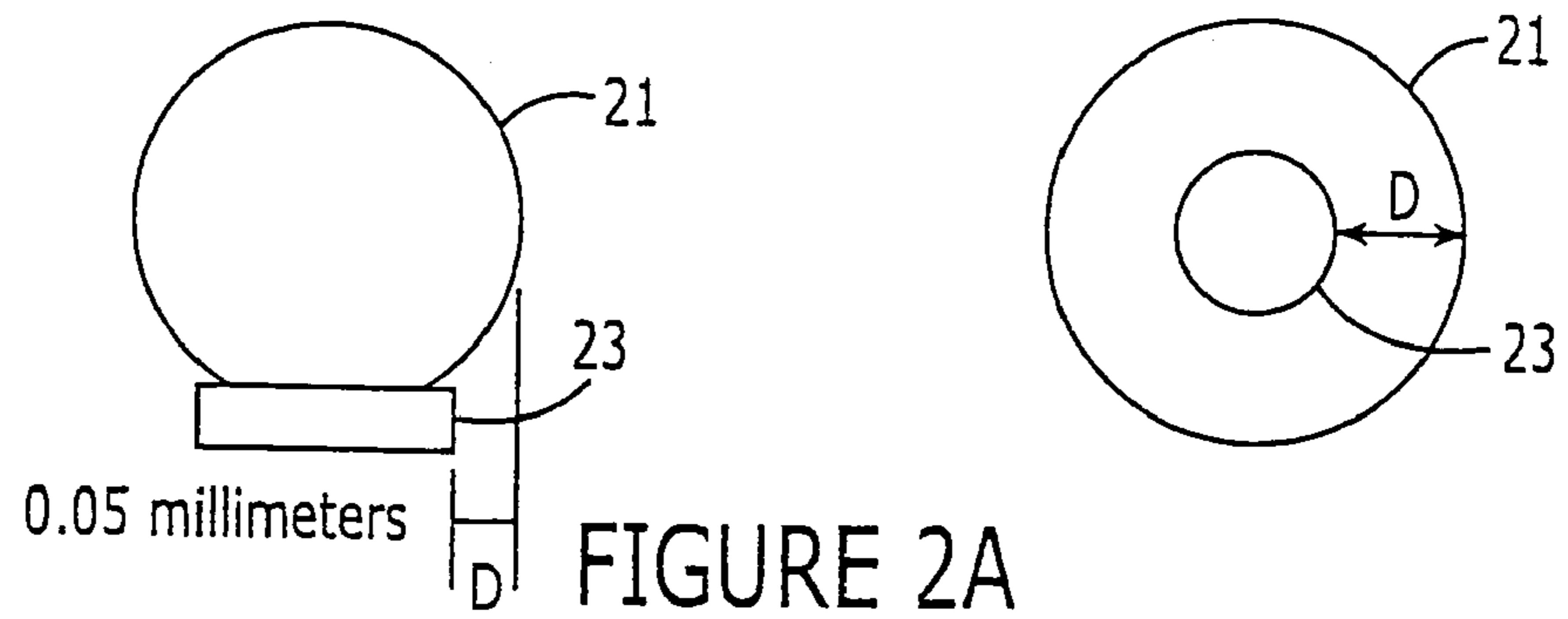

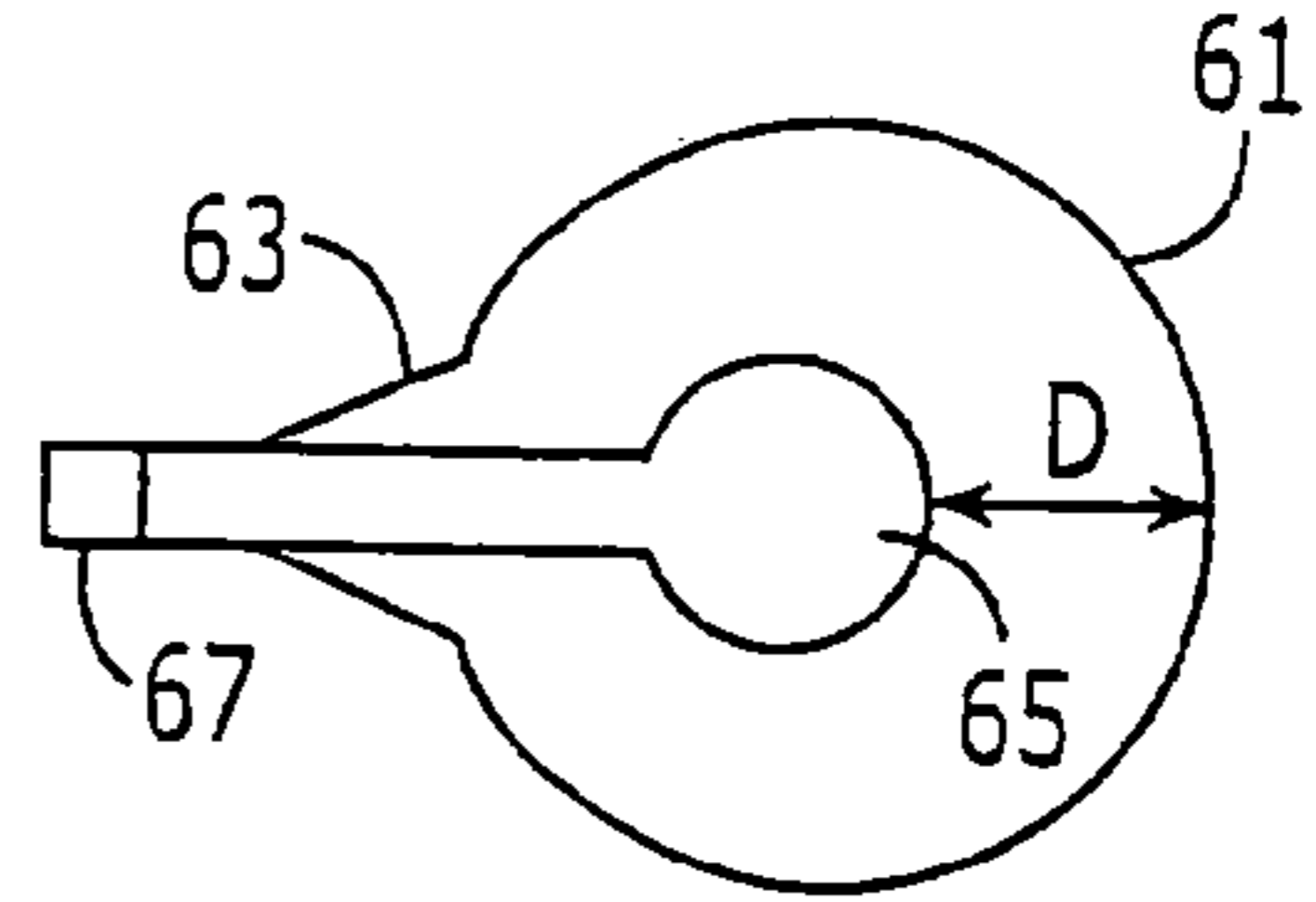
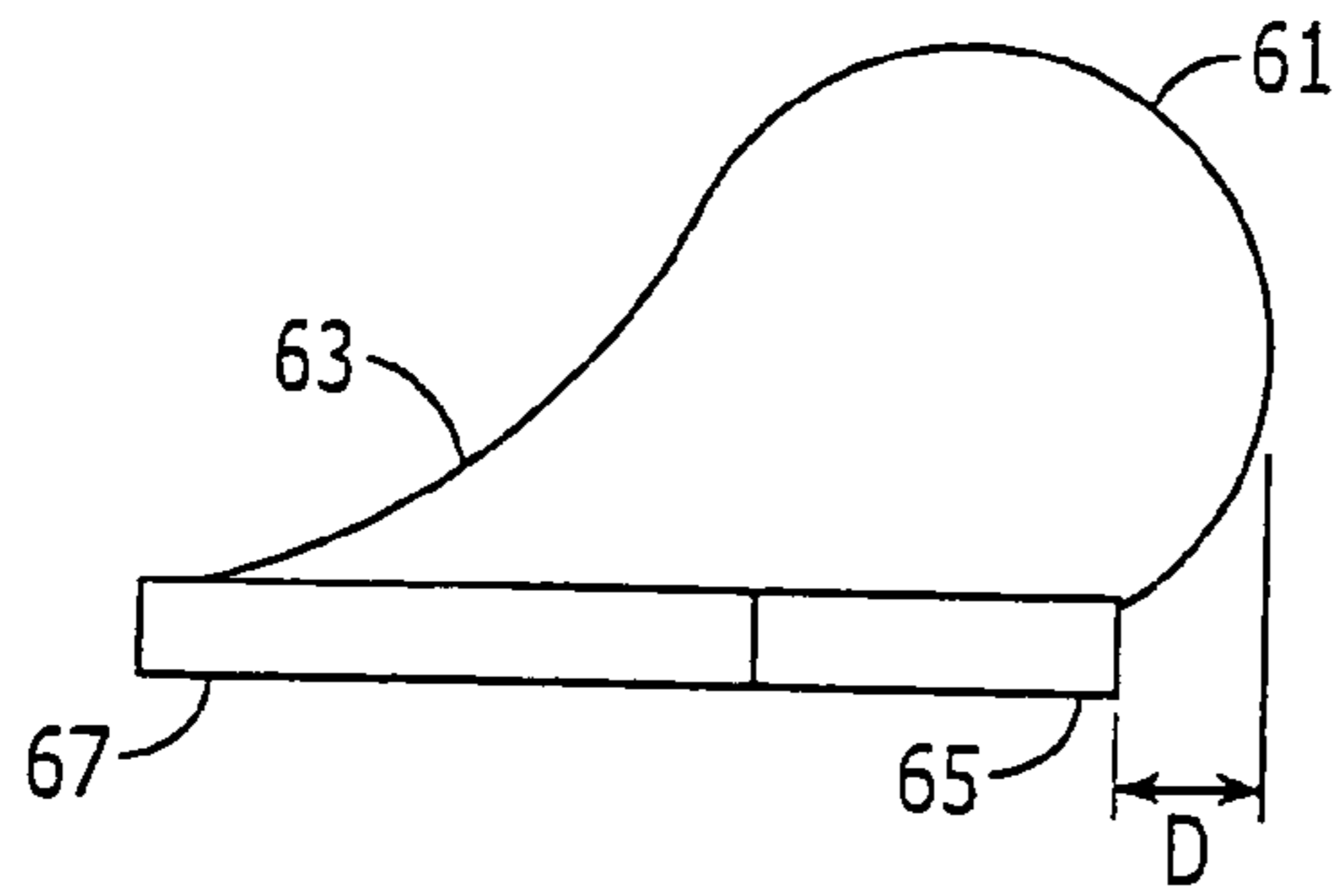

FIGURE 2E

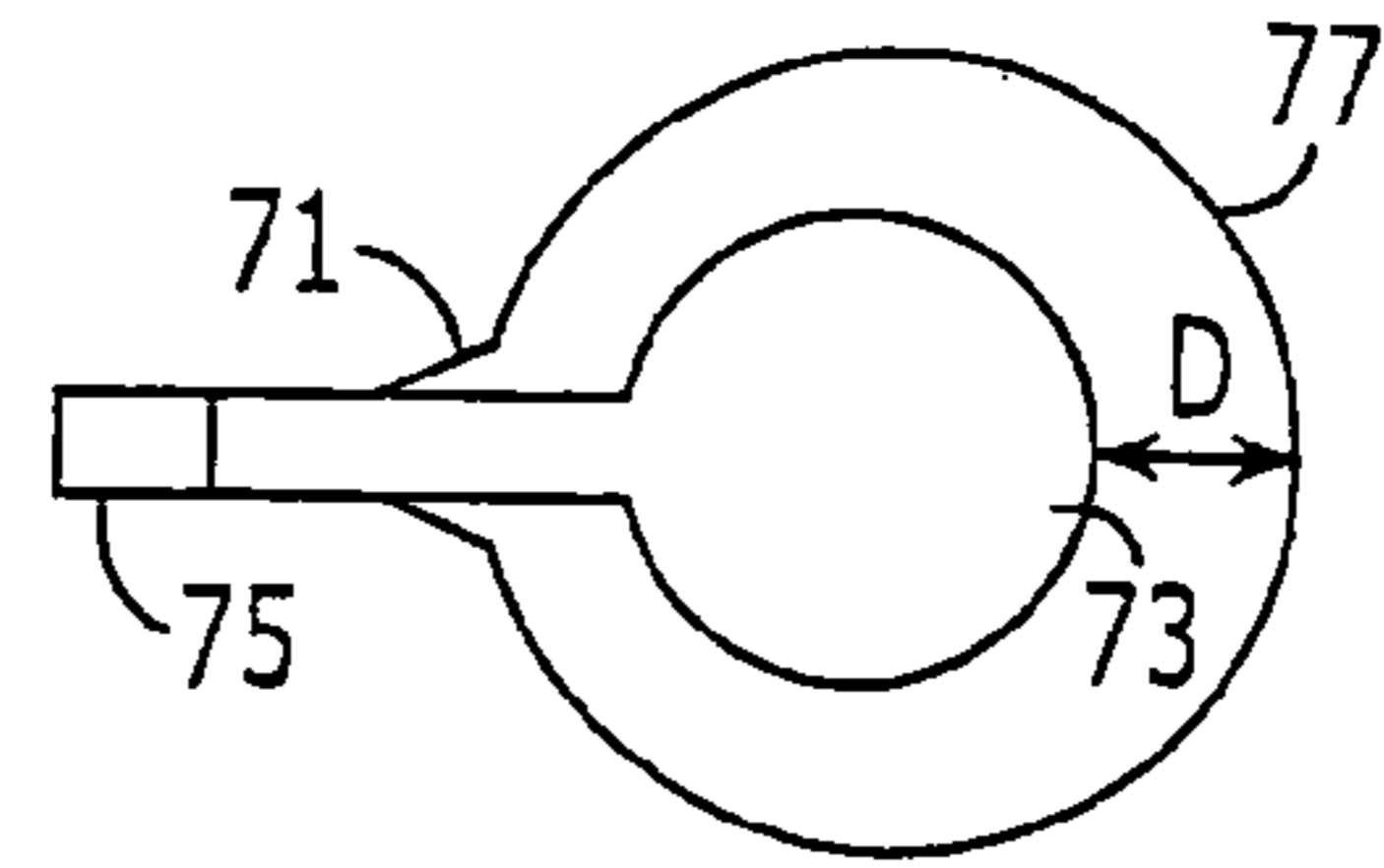
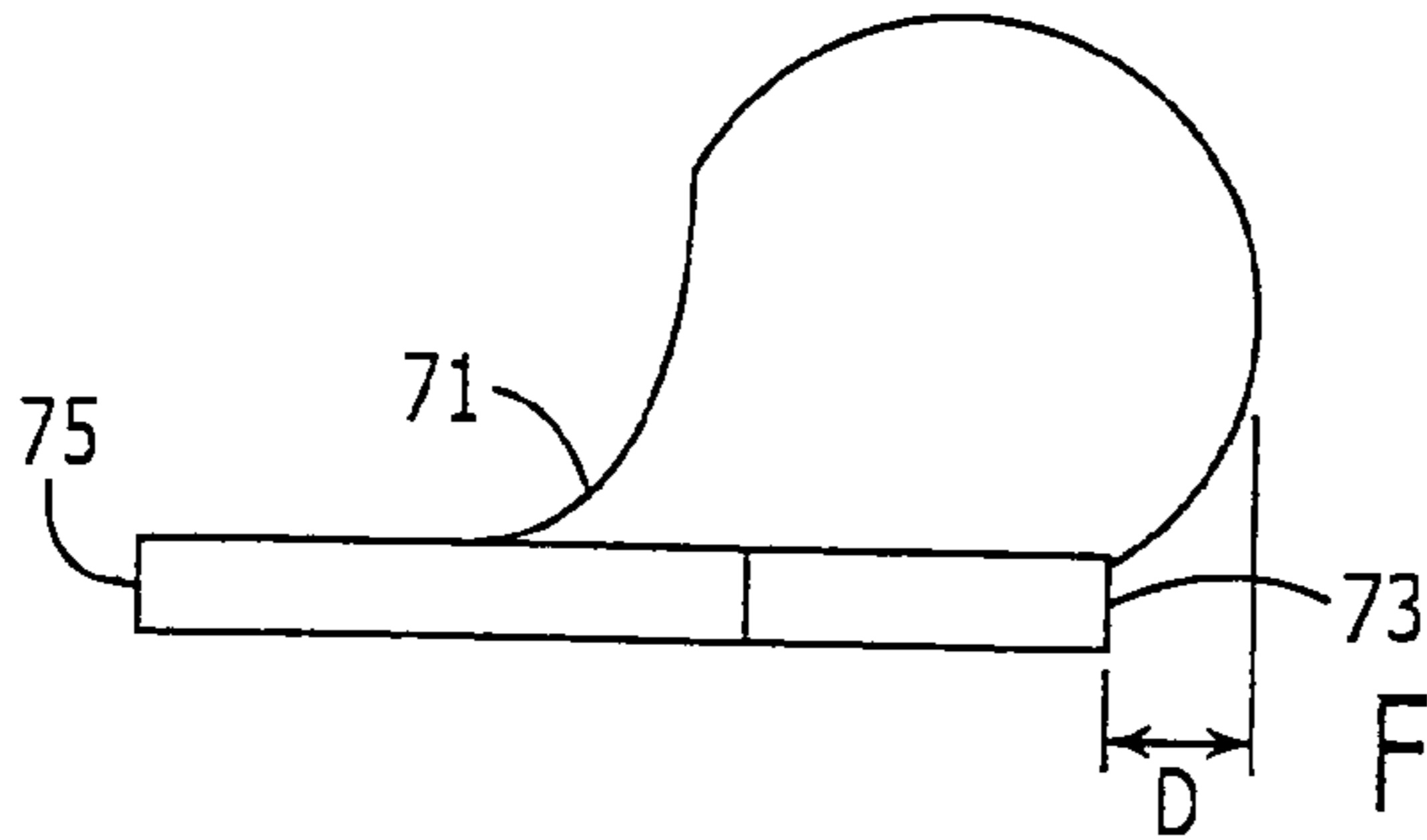

FIGURE 2F

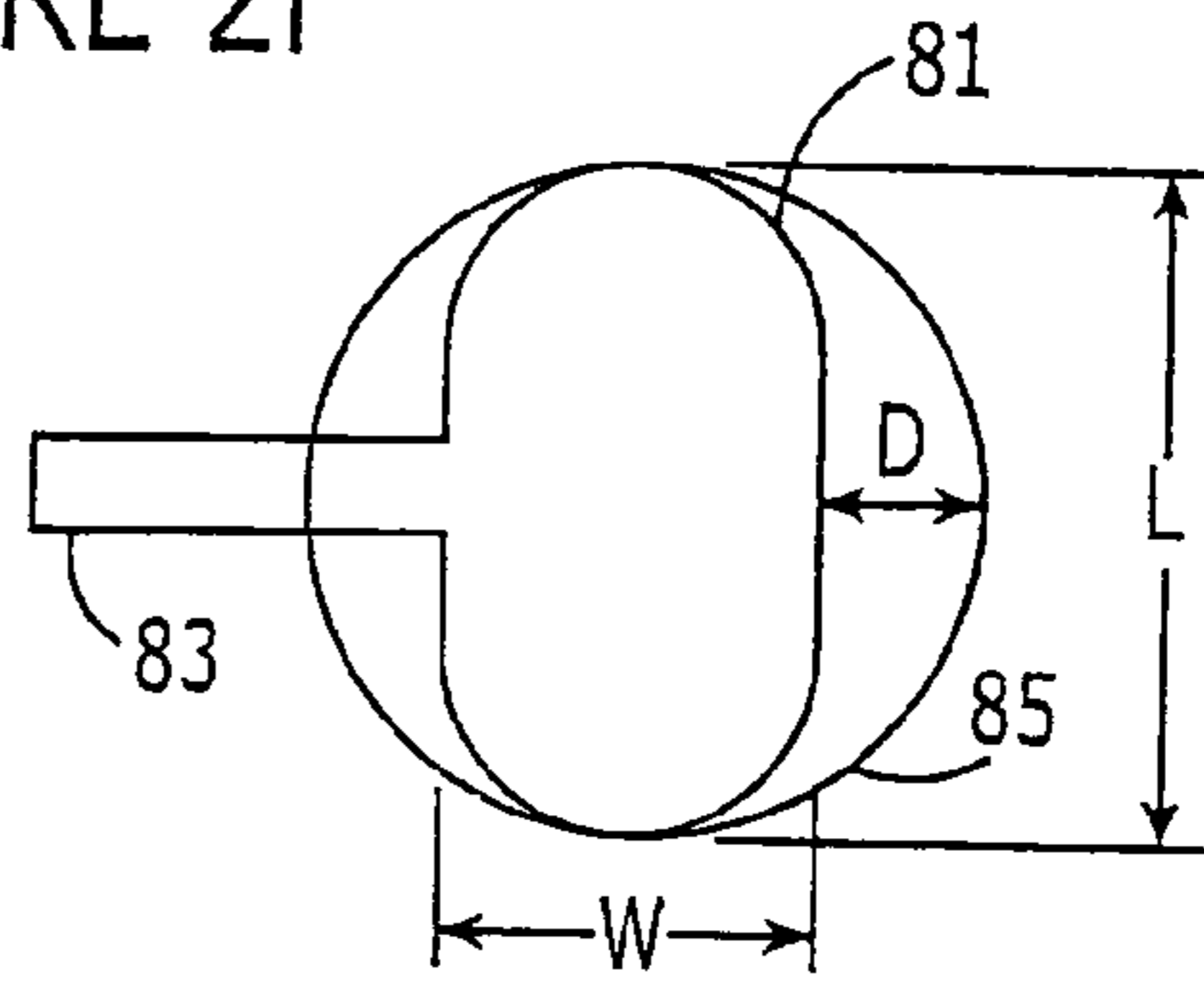
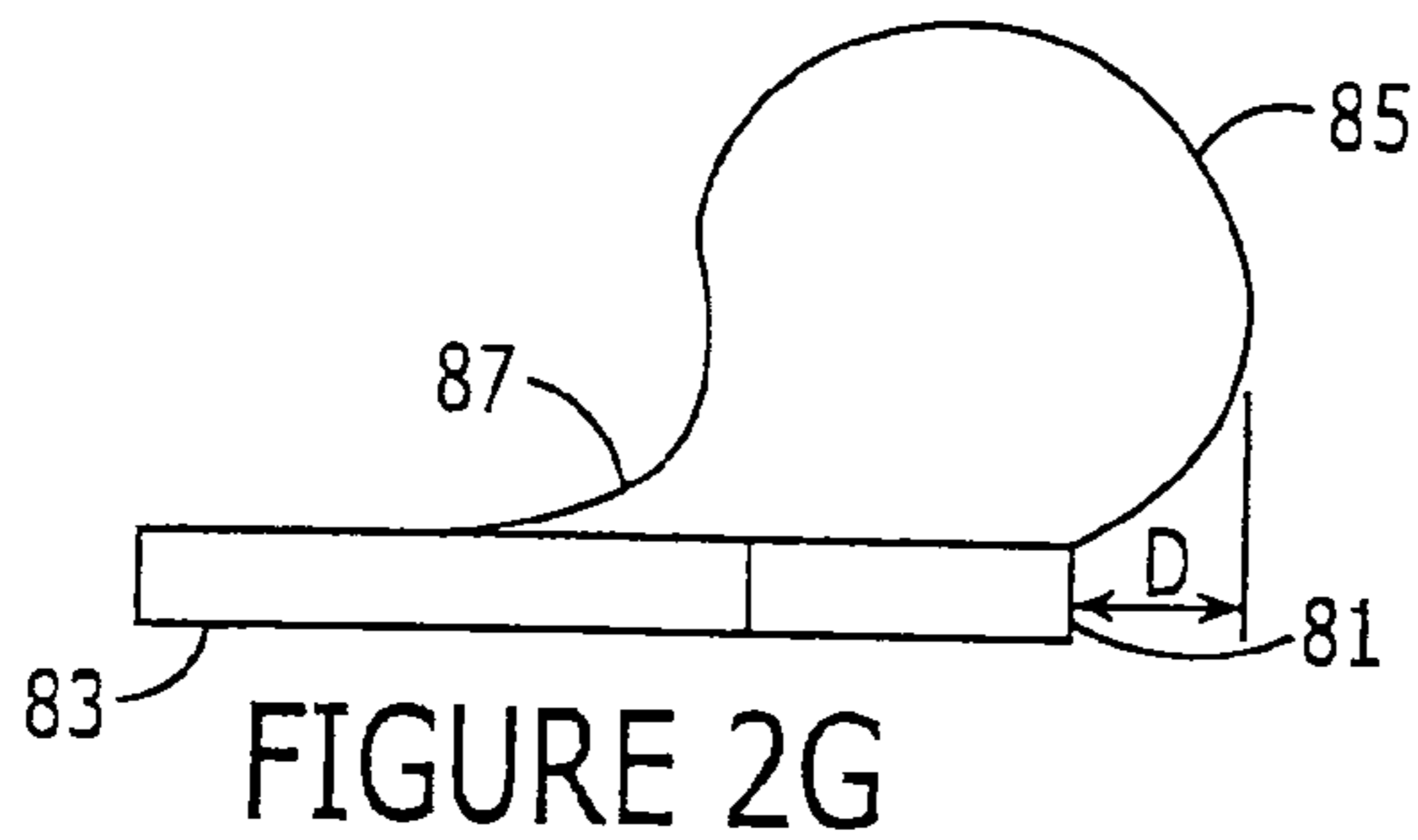

FIGURE 2G

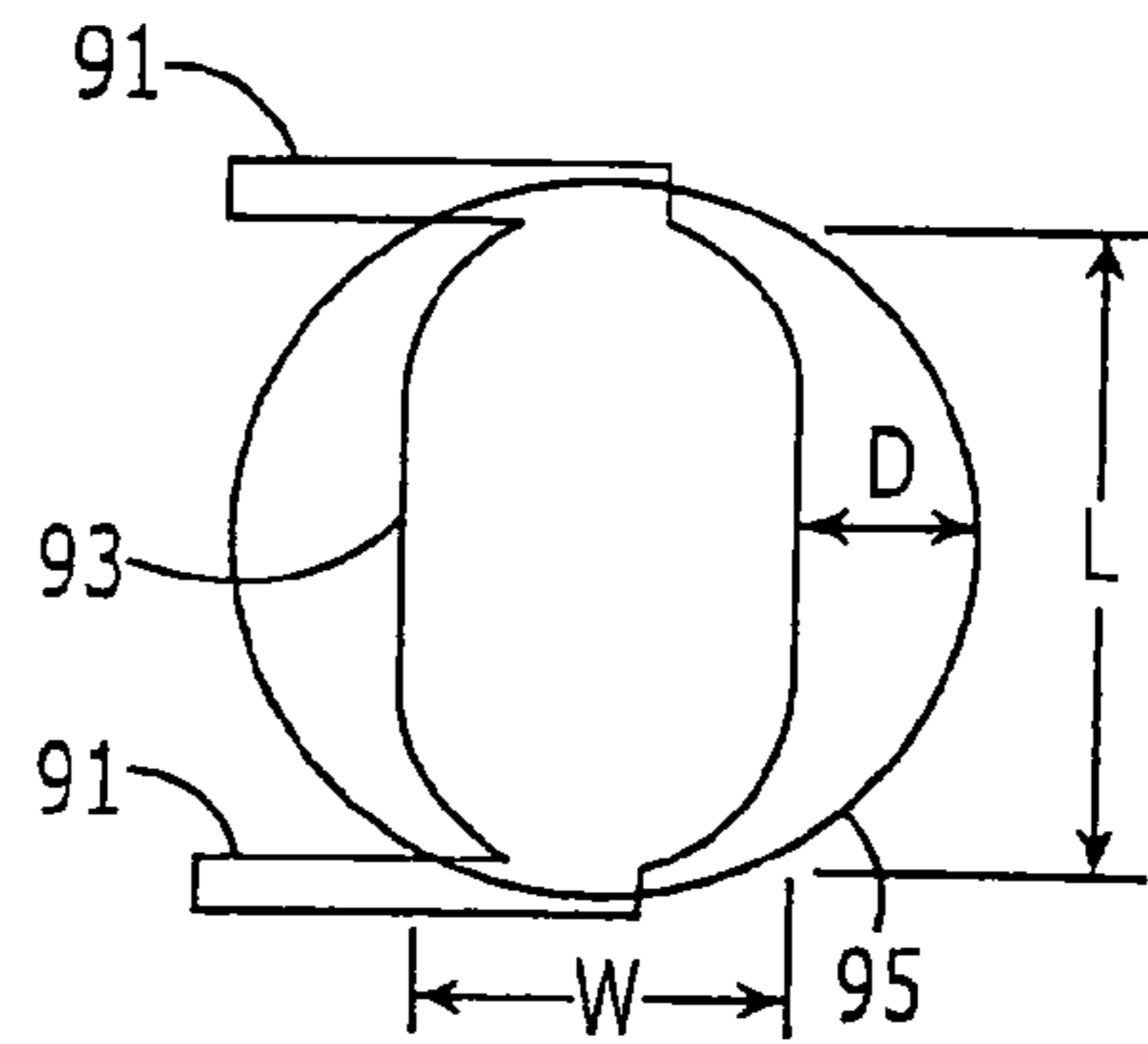
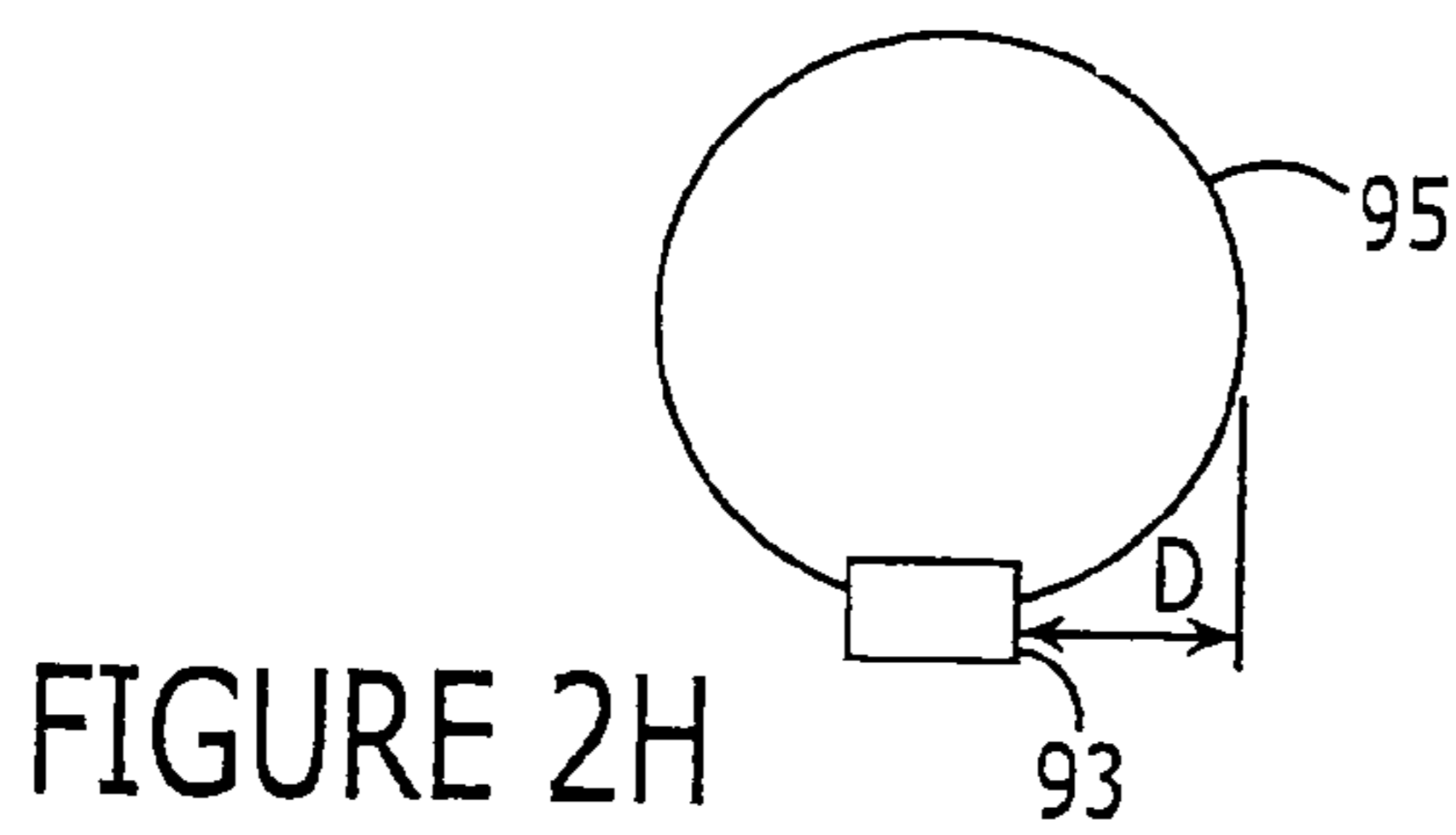

FIGURE 2H

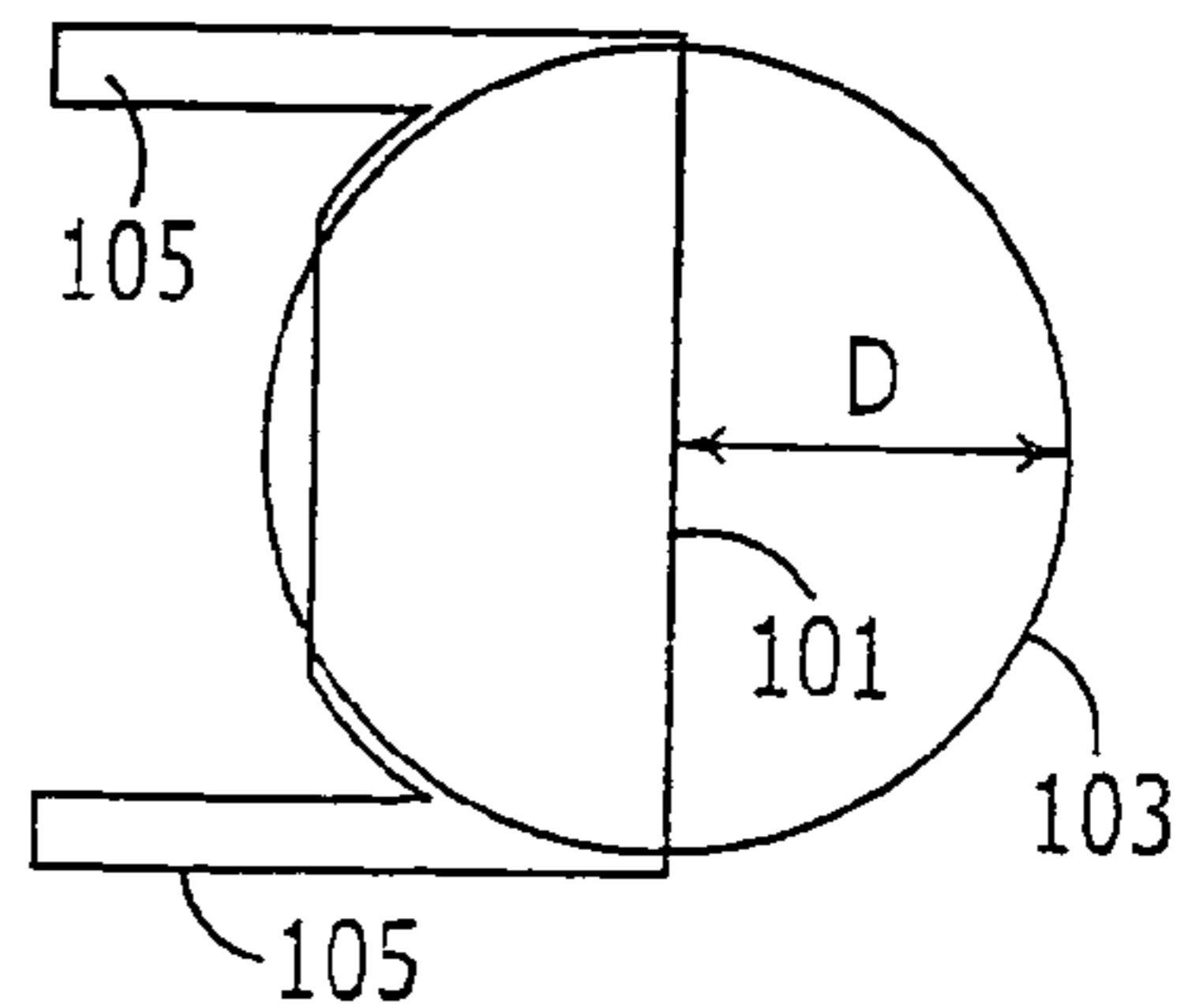
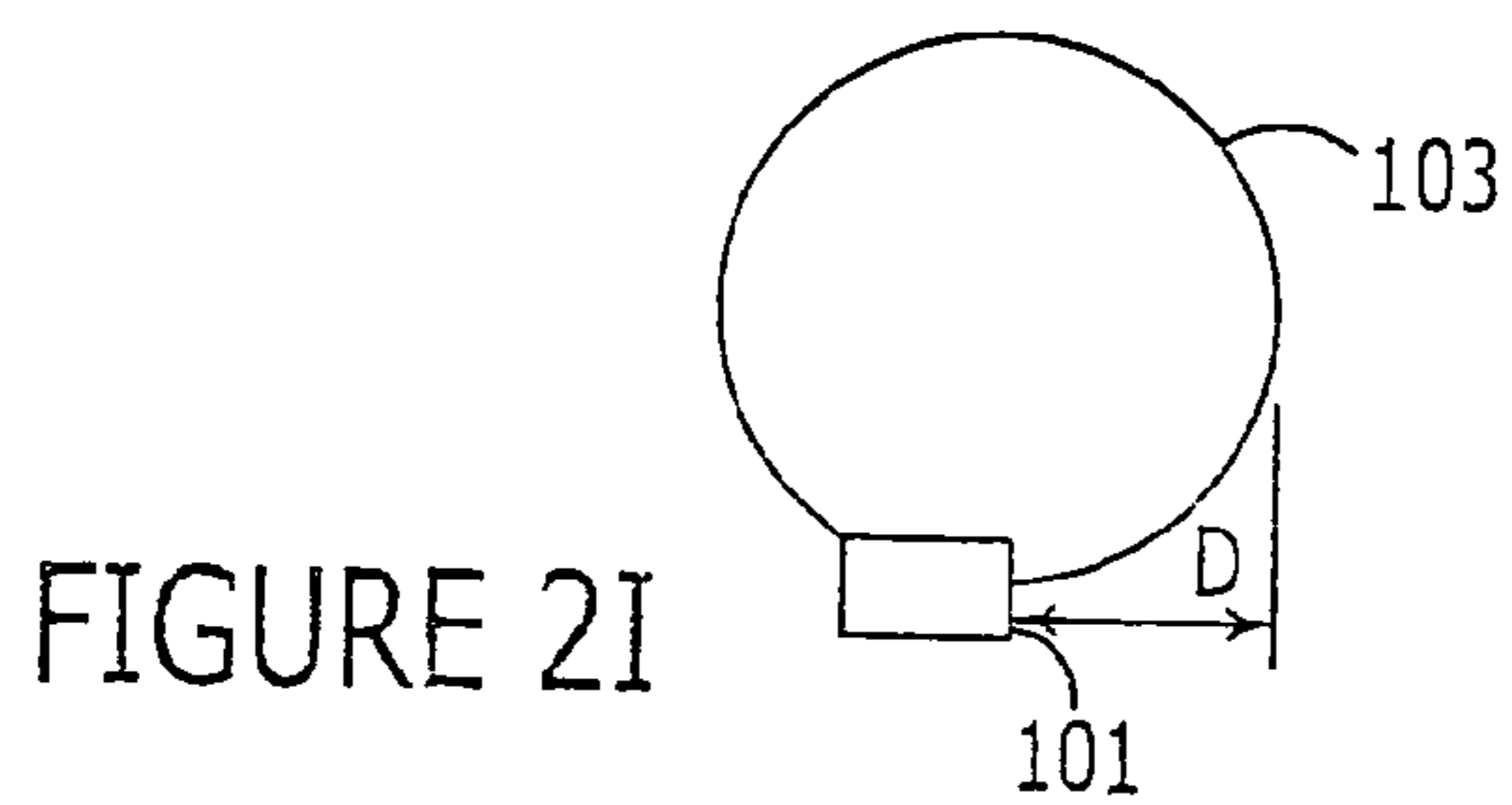

FIGURE 2I

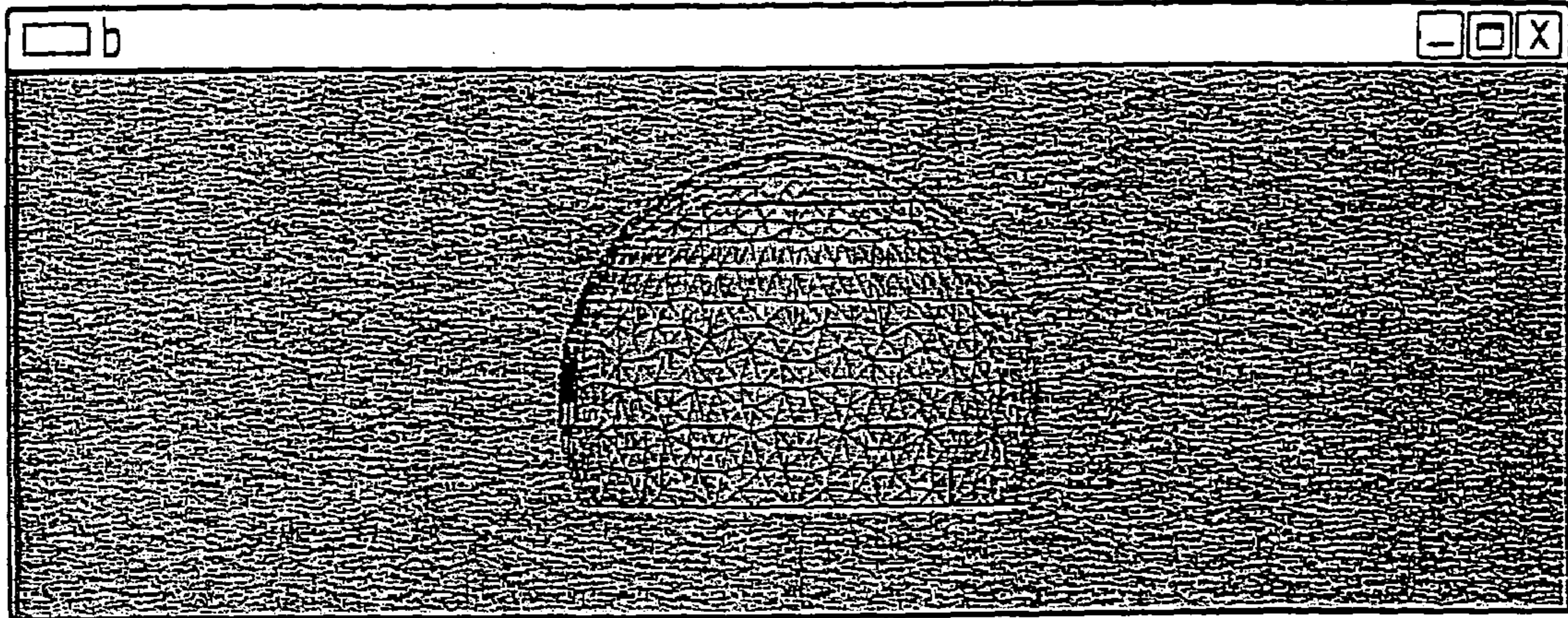

FIGURE 3

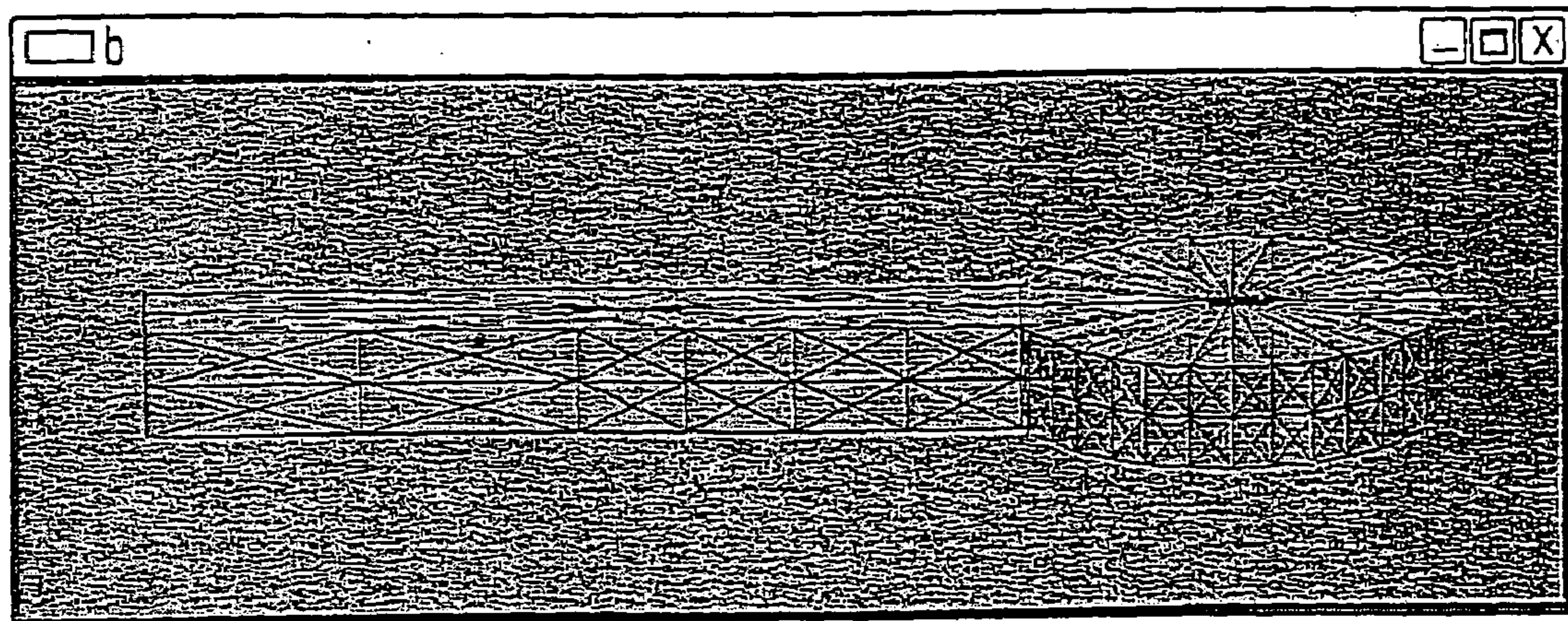

FIGURE 4

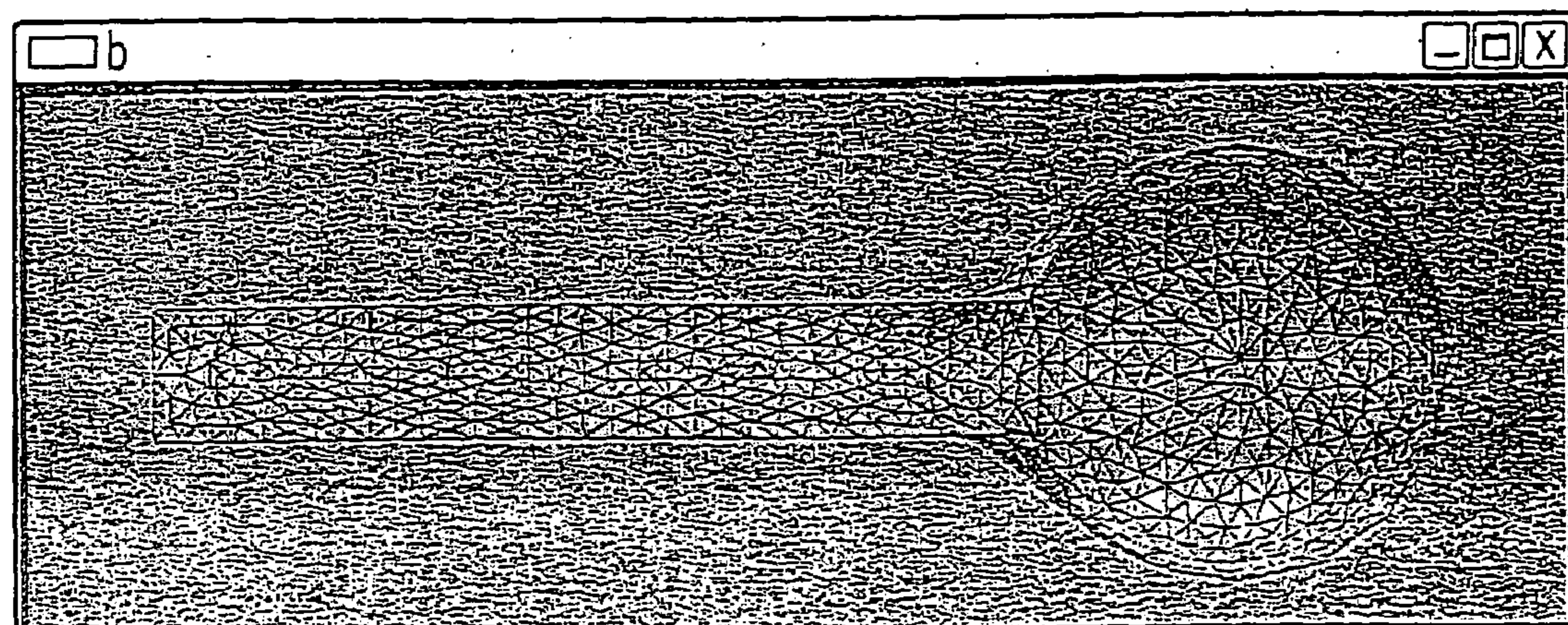

FIGURE 5

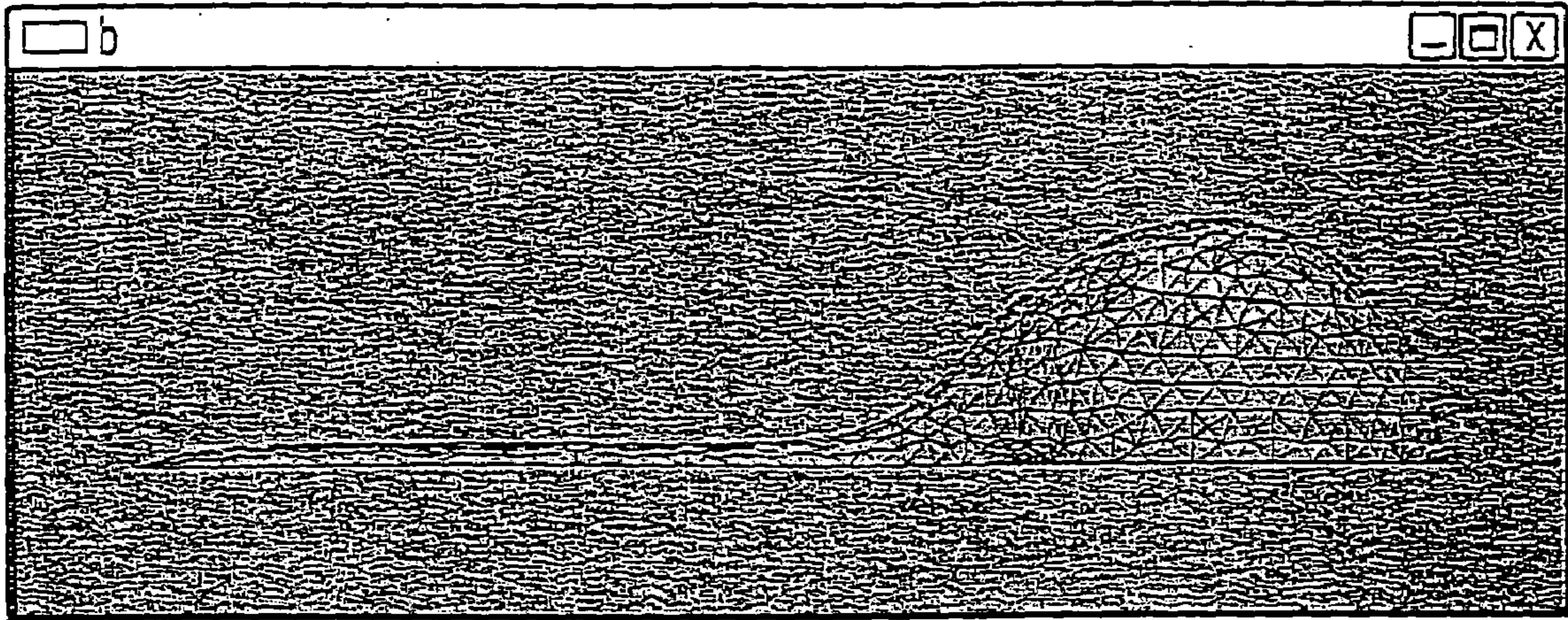

FIGURE 6

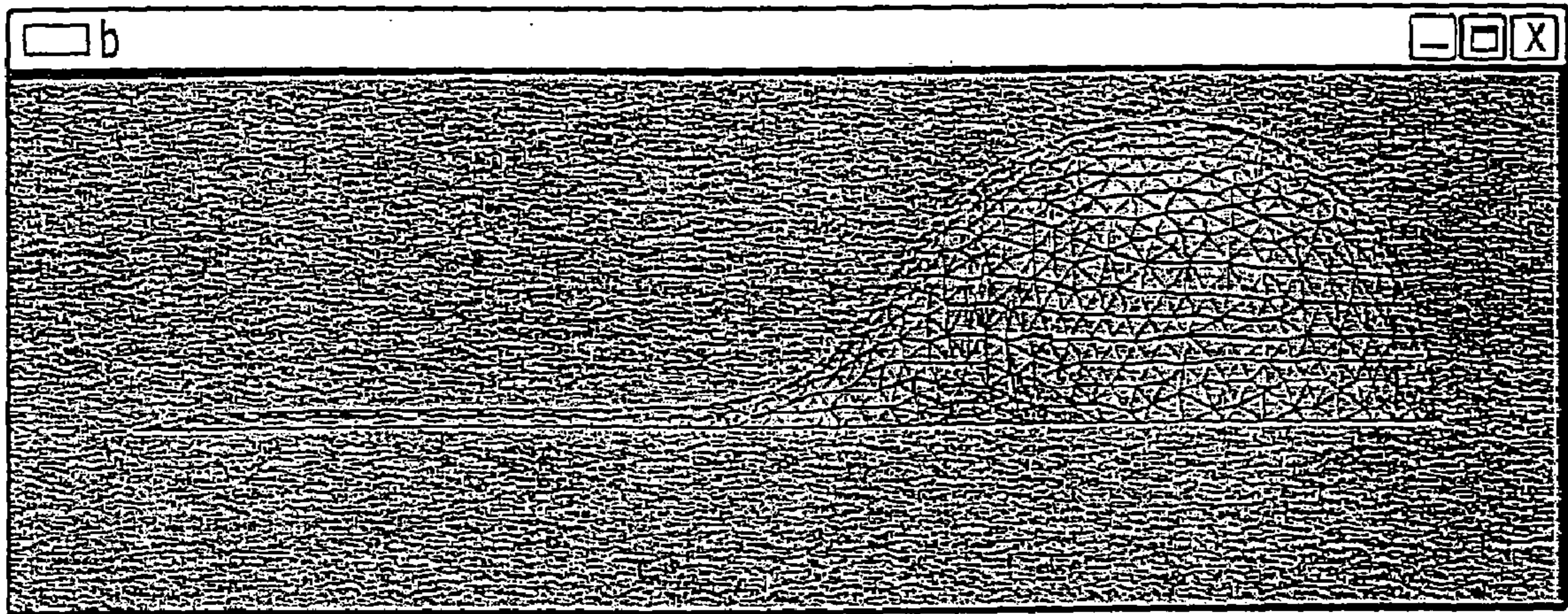

FIGURE 7

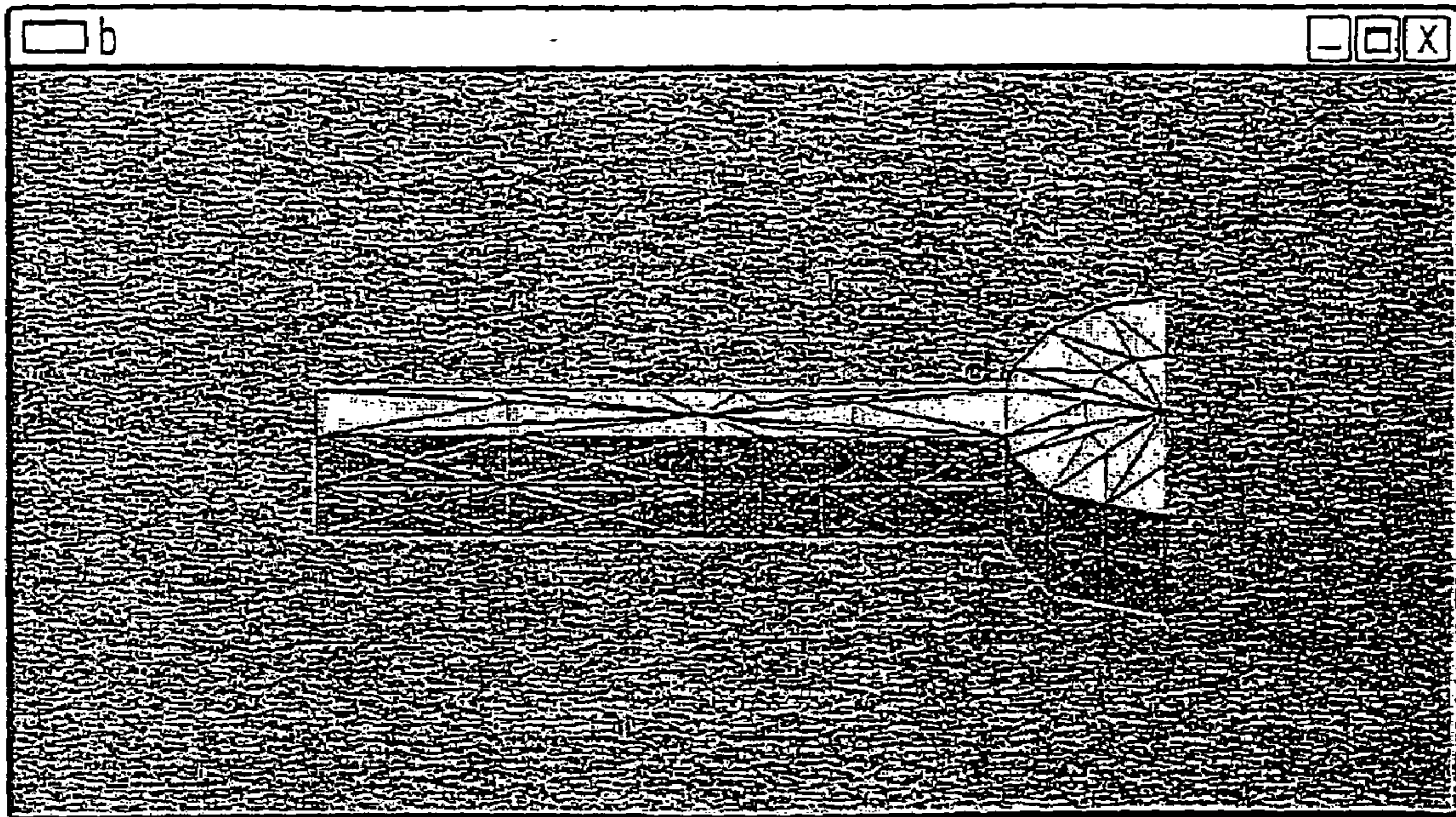

FIGURE 8

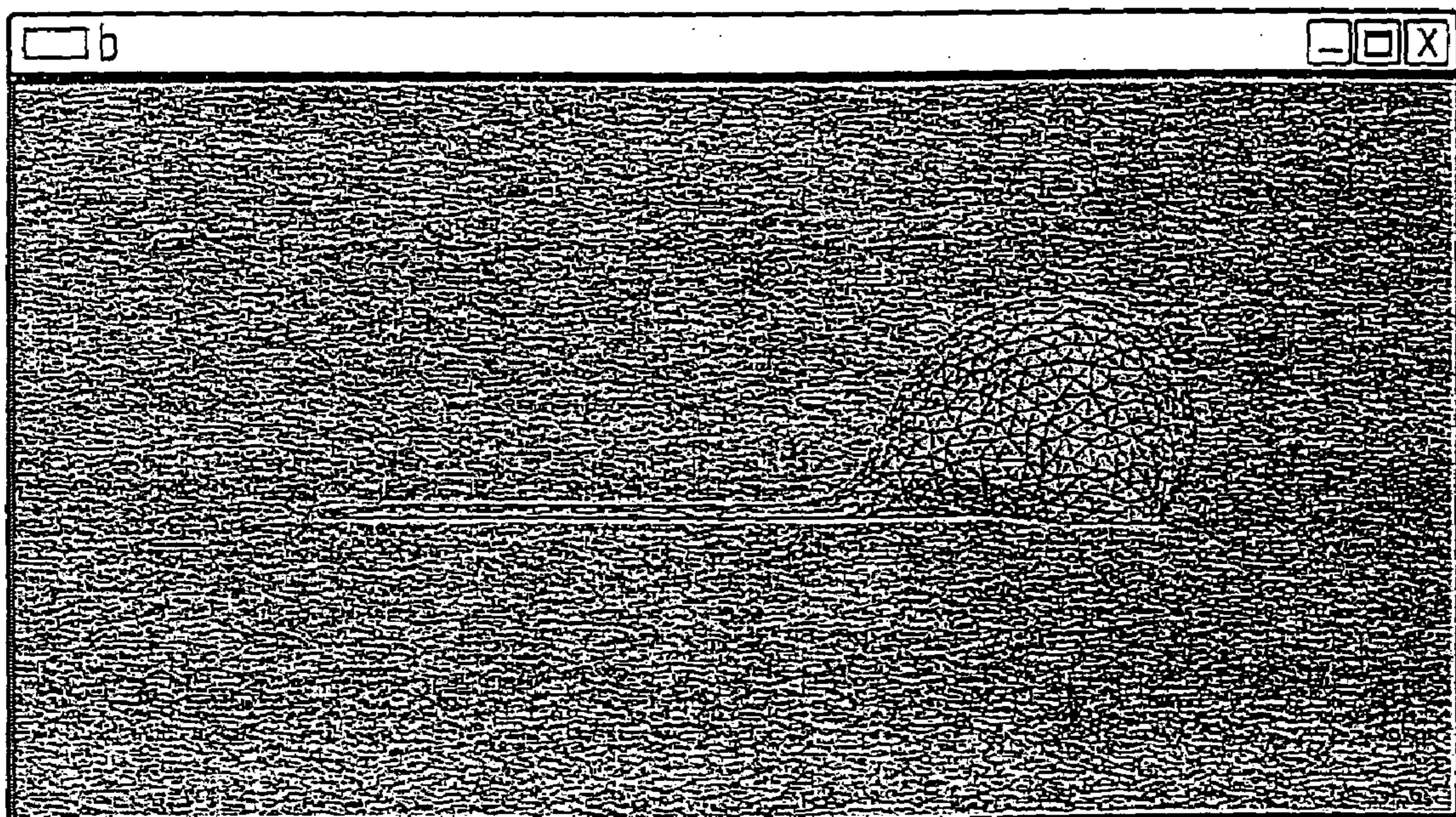

FIGURE 9

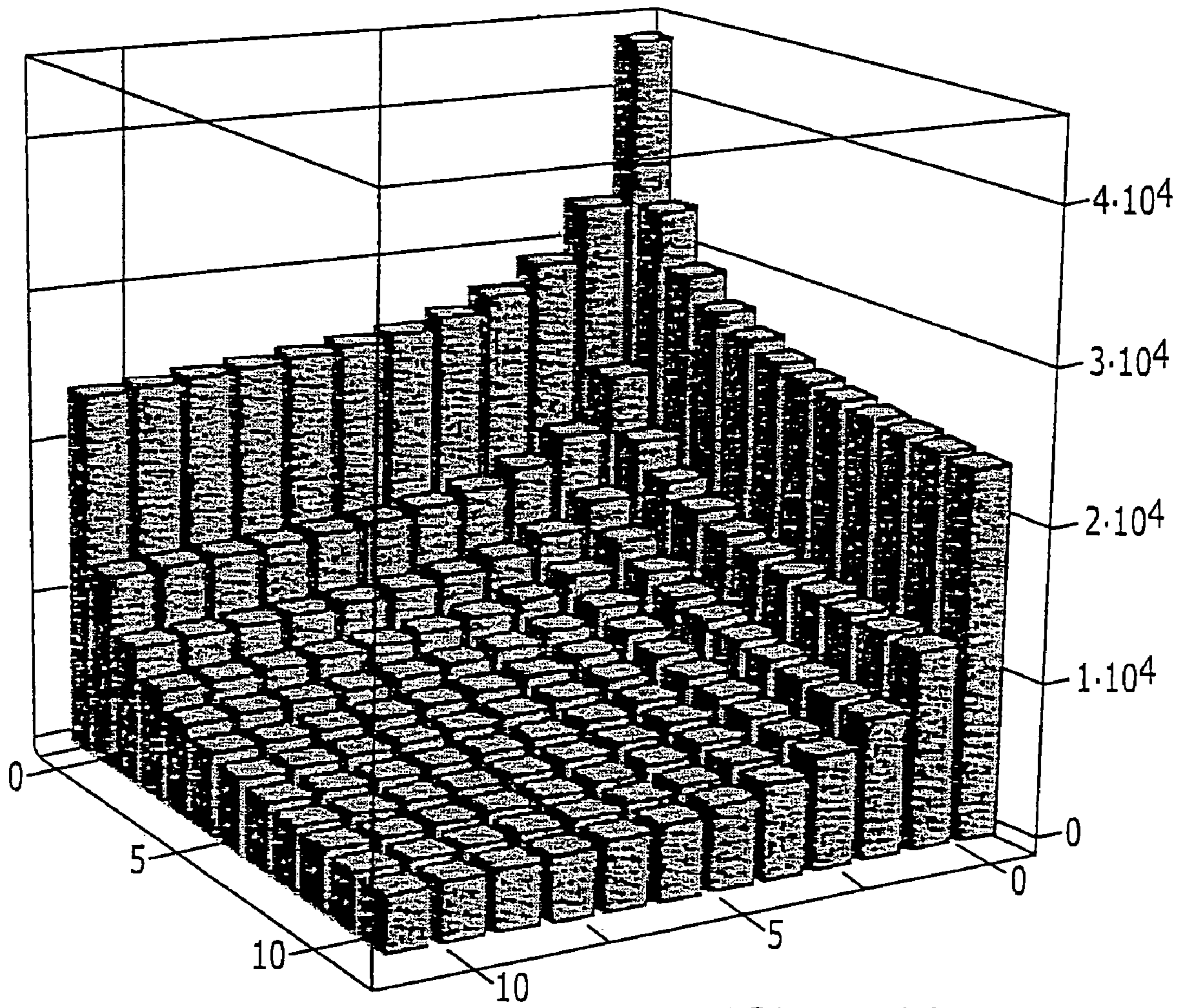

FIGURE 10

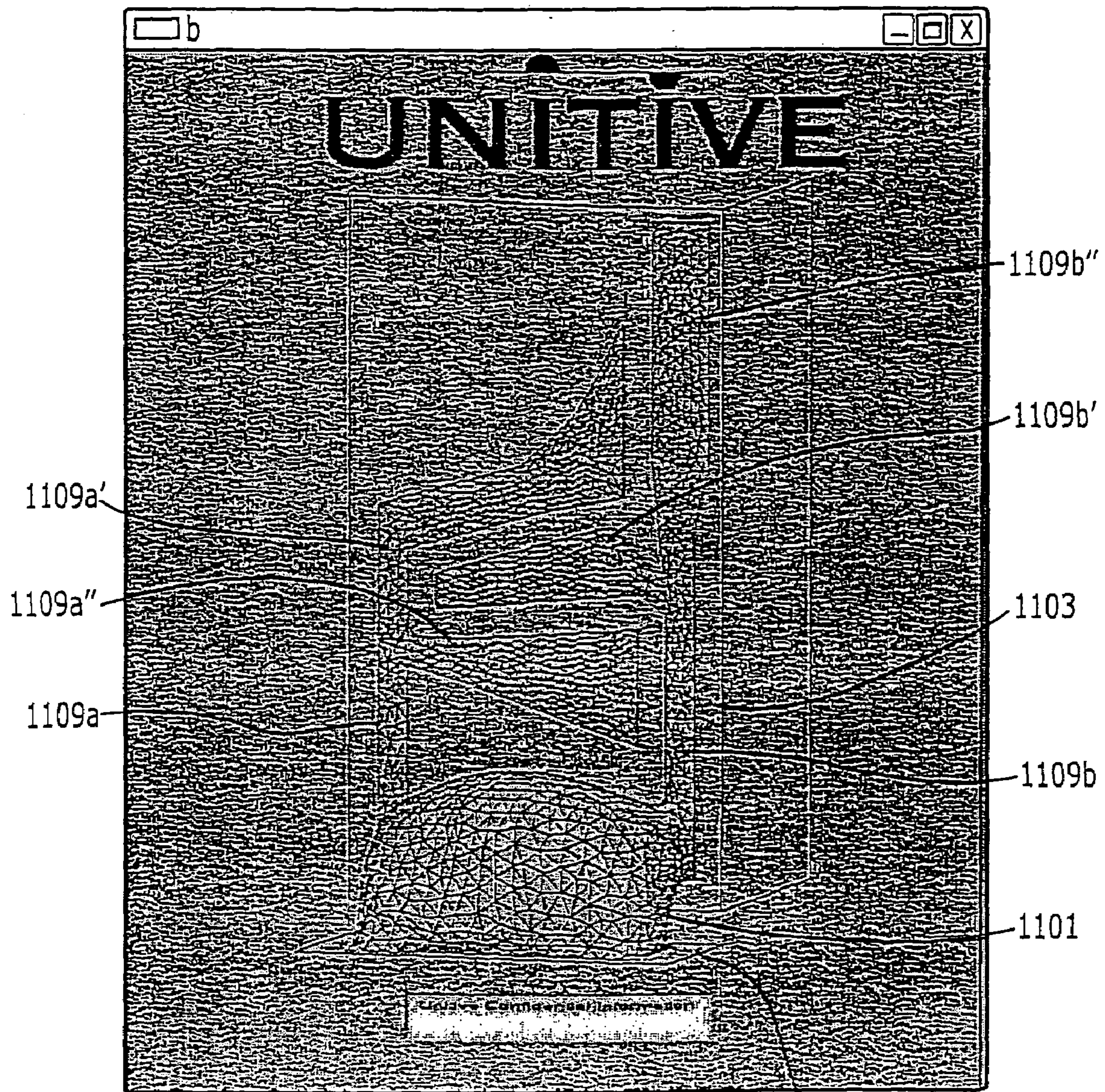

FIGURE 11

1107

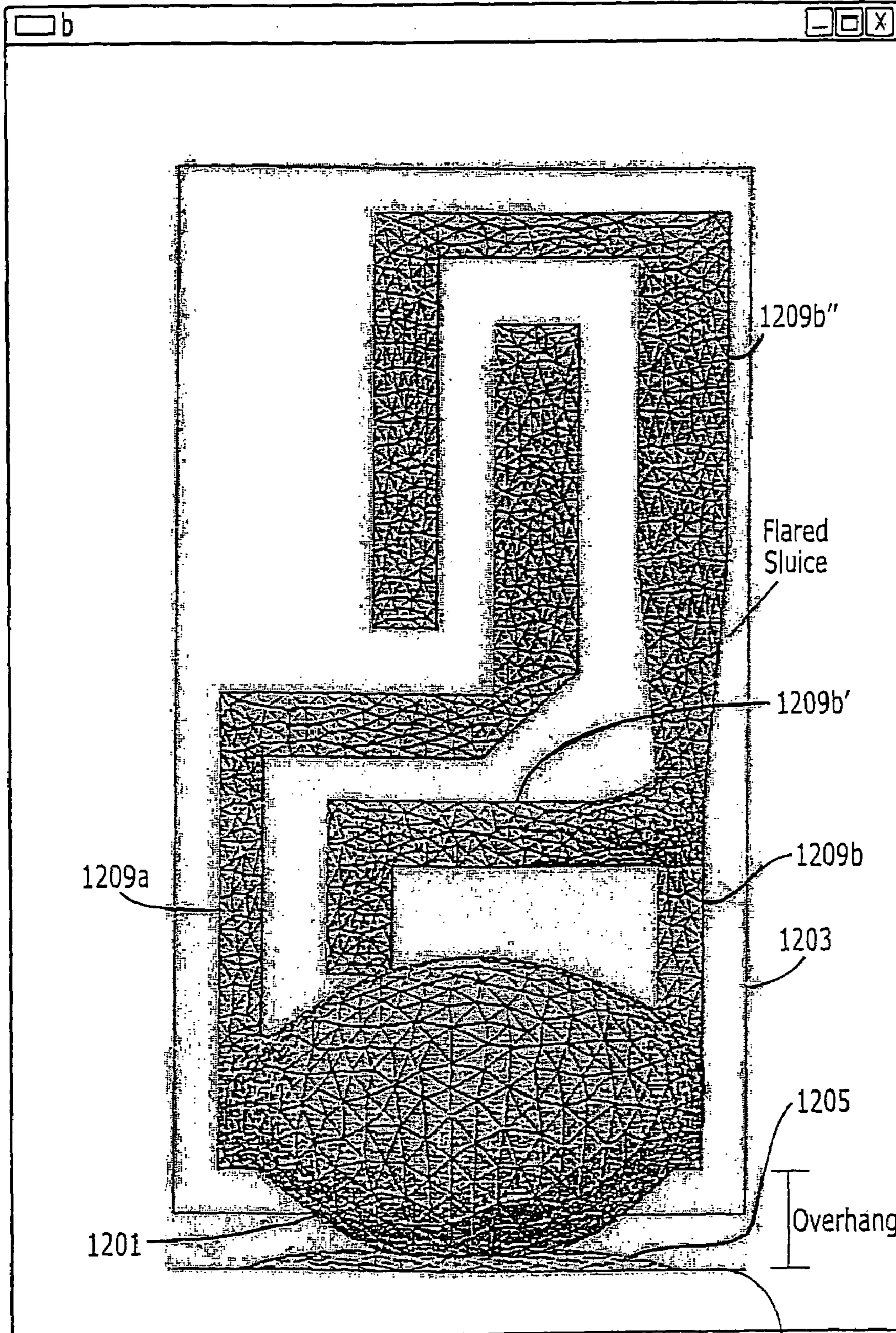

FIGURE 12

1207

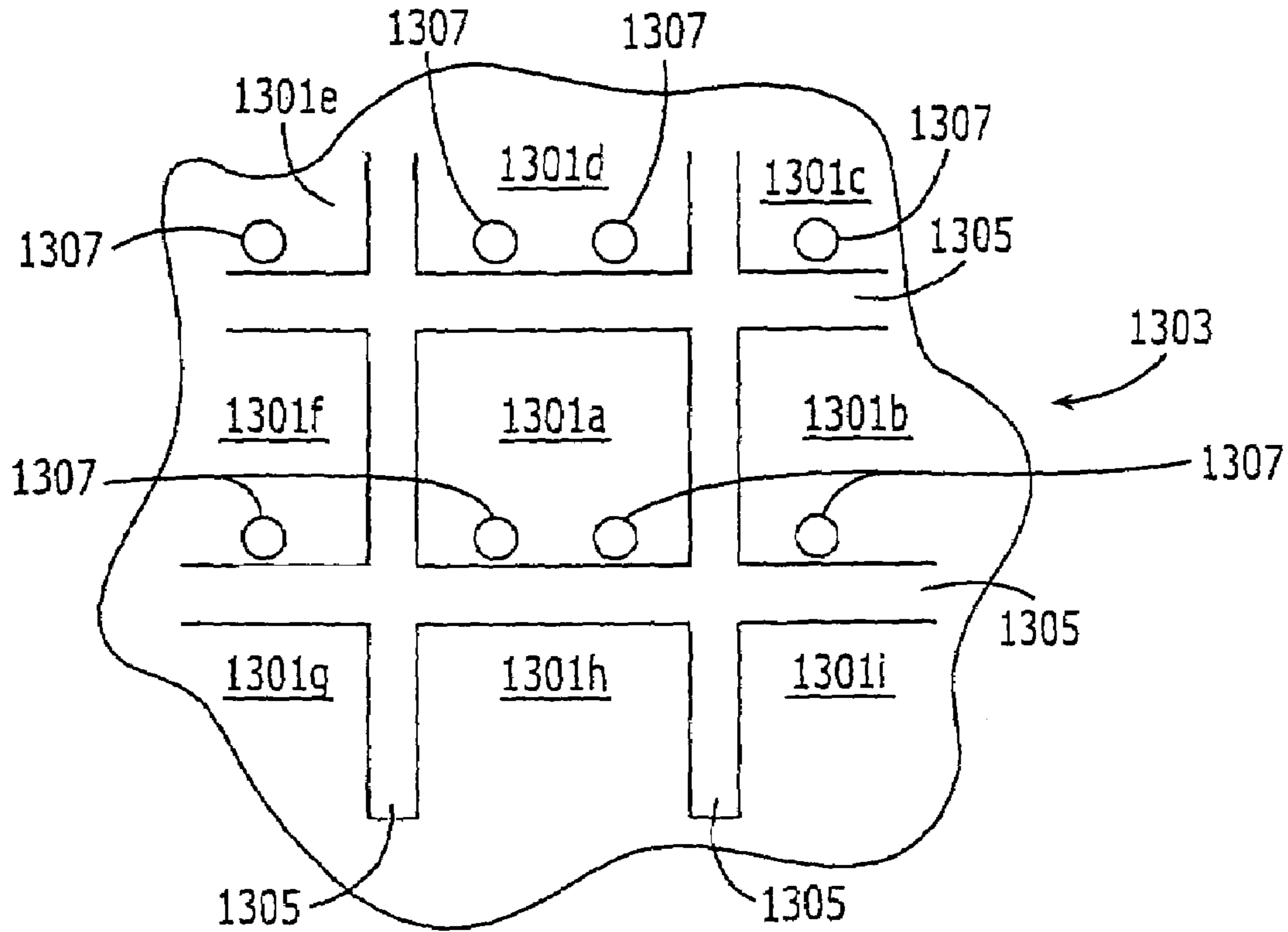

FIGURE 13A

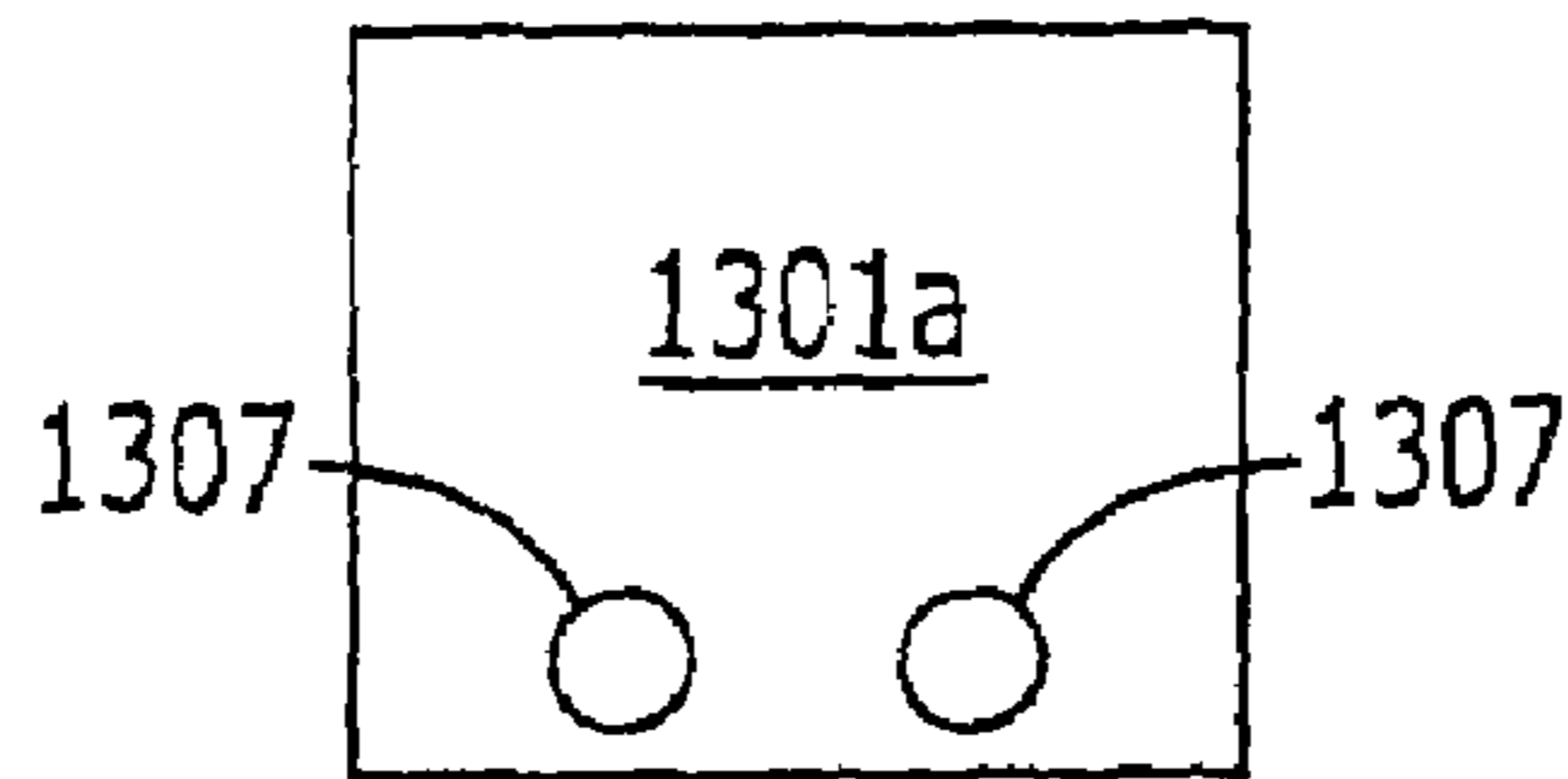

FIGURE 13B

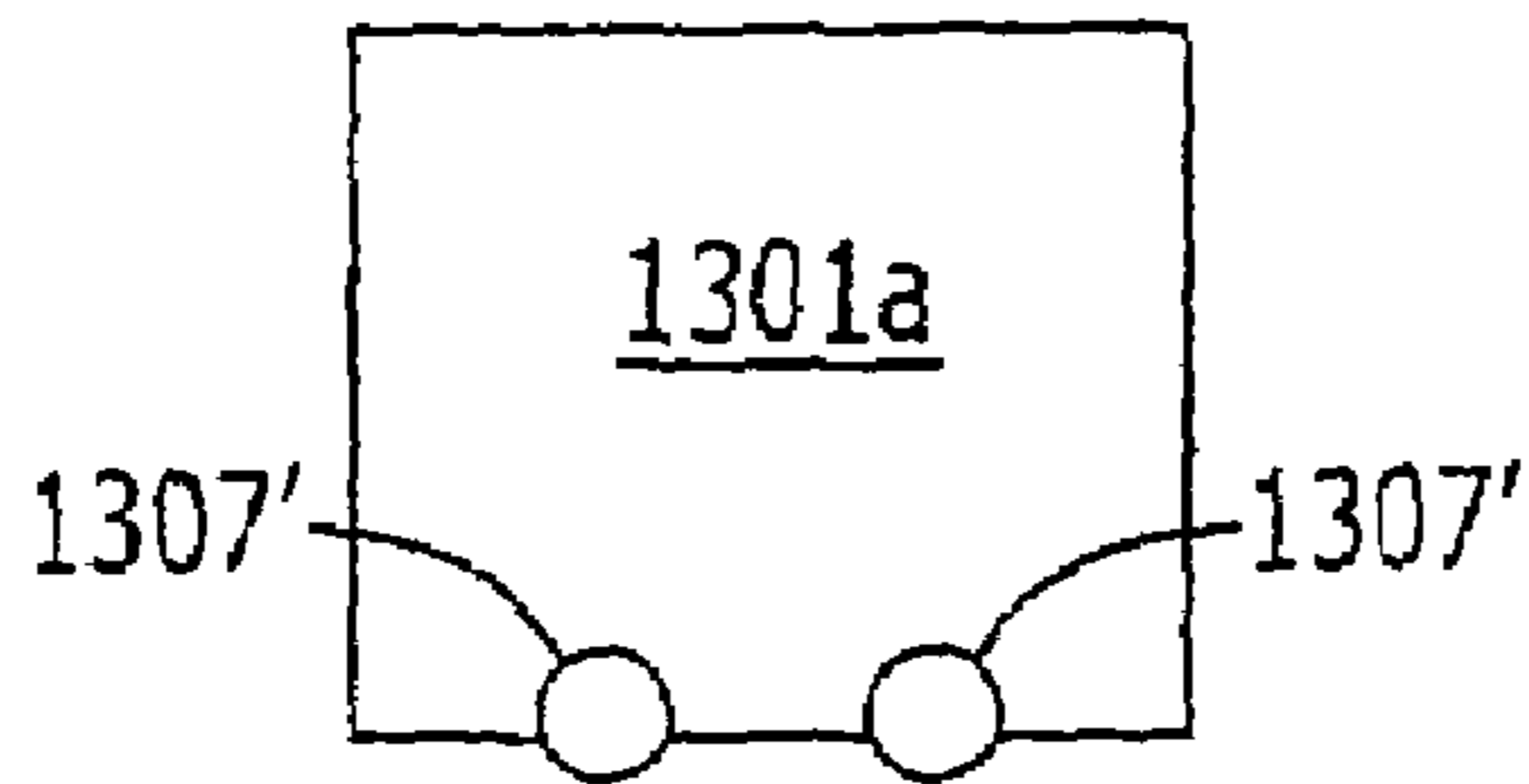

FIGURE 13C

SOLDER STRUCTURES FOR OUT OF PLANE CONNECTIONS

RELATED APPLICATION

This application claims the benefit of priority as a divisional application to U.S. patent application Ser. No. 10/965,640 filed Oct. 13, 2004, U.S. Pat. No. 7,049,216, which claims the benefit of priority to U.S. Provisional Application No. 60/510,819 filed Oct. 14, 2003. The disclosures of both of the above referenced applications are hereby incorporated herein in their entirety by reference.

FIELD OF THE INVENTION

The present invention relates to the field of electronics, and more particularly, to structures for bonding electronic substrates and related methods.

BACKGROUND

In packaging microelectronic devices, such as packaging integrated circuit chips on printed circuit boards, the integrated circuit chips are generally mounted parallel to and facing the printed circuit board such that faces of the integrated circuit chips are adjacent a face of the circuit board. This packaging technology allows a large number of input/output connections between the integrated circuit chips and the printed circuit board, especially when solder bump technology is used over the entire face of the integrated circuit chips. However, this technology may limit a packaging density, because the large faces of the integrated circuit chips are mounted adjacent the face of the printed circuit board.

To increase the packaging density of chips on a printed circuit board, three-dimensional packaging has been proposed, wherein the chips are mounted orthogonal to the circuit board so that edges of the chips are adjacent the face of the circuit board. See, for example, U.S. Pat. No. 5,347,428 to Carson et al. entitled "Module Comprising IC Memory Stack Dedicated to and Structurally Combined With an IC Microprocessor Chip" and U.S. Pat. No. 5,432,729 to Carson et al. entitled "Electronic Module Comprising a Stack of IC Chips Each Interacting With an IC Chip Secured to the Stack", both of which are assigned to Irvine Sensors Corporation. In these patents, solder bumps are used to connect the edges, rather than the faces of integrated circuit chips to a substrate. Unfortunately, an edge-to-face connection may be difficult and costly to produce.

U.S. Pat. No. 5,113,314 to Wheeler et al. entitled "High Speed, High Density Chip Mounting" describes another three-dimensional packaging technique. The '314 patent describes a plurality of integrated circuit chips whose active faces are perpendicular to a chip carrier. Solder bumps are used to connect pads on the chips to pads on the substrate.

An issue in using solder bump technology to interconnect a three-dimensional package is how to get the solder bump to bridge from one substrate to another. In particular, it may be difficult to form solder which extends beyond the edge of a chip because a chip sawing or dicing operation may remove solder which extends beyond the chip edge. Moreover, during solder reflow, the solder may take the shape of a hemisphere or partial hemisphere on a contact pad. Thus, it may be difficult to cause the solder on one contact pad to extend onto another contact pad, in a three-dimensional package. Even if solder is placed on a pair of adjacent contact pads in a three-dimensional package, it may be difficult to cause the reflowed solder to join up, rather than forming individual solder bumps.

Solder interconnections are also discussed in U.S. Pat. Nos. 5,793,116; 6,418,033; and 6,392,163. Each of these patents are assigned to the assignee of the present invention, and the disclosures of each of these patents are hereby incorporated herein in their entirety by reference.

SUMMARY

According to embodiments of the present invention, a solder structure may include a substrate and a solder wettable pad on the substrate adjacent an edge of the substrate. The solder wettable pad may have a length parallel to the edge of the substrate and a width perpendicular to the edge of the substrate wherein the length parallel to the edge of the substrate is greater than the width perpendicular to the edge of the substrate. In addition, a solder bump on the solder wettable pad may extend laterally from the solder wettable pad at least to within about 10 microns of the edge of the substrate. According to some embodiments, the solder bump may extend laterally from the solder wettable pad to and/or beyond the edge of the substrate.

According to additional embodiments of the present invention, a method of forming a solder structure may include providing a wafer including a plurality of die therein, and forming a solder wettable pad on one of the die adjacent an edge of the die. The solder wettable pad may have a length parallel to the edge of the die and a width perpendicular to the edge of the die wherein the length parallel to the edge of the die is greater than the width perpendicular to the edge of the die. A solder bump may be formed on the solder wettable pad, and the die may be separated from the wafer along the edge of the die after plating the solder bump on the solder wettable pad. After separating the die from the wafer, the solder bump on the solder wettable pad may be reflowed so that the solder structure extends laterally from the solder wettable pad toward the edge of the die. According to some embodiments, the solder bump may extend laterally to and/or beyond the edge of the die.

According to still additional embodiments of the present invention, a method of forming a solder structure may include providing a wafer including a plurality of die therein, and forming a solder wettable pad on one of the die adjacent an edge of the die. A solder bump may be formed on the solder wettable pad such that the solder bump is maintained within the edge of the die, and the die may be separated from the wafer along the edge of the die after forming the solder bump on the solder wettable pad. After separating the die from the wafer, the solder bump on the solder wettable pad may be subjected to reflow so that the solder bump extends laterally from the solder wettable pad to at least within about 10 microns of the edge of the die. According to some embodiments, the solder bump may extend to and/or beyond the edge of the die.

According to yet additional embodiments of the present invention, a method of forming a solder structure may include forming a solder wettable pad on a substrate adjacent an edge of the substrate. The solder wettable pad may have a length parallel to the edge of the substrate and a width perpendicular to the edge of the substrate wherein the length parallel to the edge of the substrate is greater than the width perpendicular to the edge of the substrate. In addition, a solder bump may be formed on the solder wettable pad wherein the solder bump extends laterally from the solder wettable pad to at least within about 10 microns of the edge of the substrate. Accord-

ing to some embodiments, the solder bump may extend to and/or beyond the edge of the substrate.

BRIEF DESCRIPTION OF THE DRAWINGS

FIG. 1 is a diagram illustrating surface curvature at a point on an air-liquid interface according to embodiment of the present invention.

FIGS. 2A-I are cross-sectional and corresponding top views of bump structures according to embodiments of the present invention.

FIGS. 3-9, 11, and 12 are views of solder structures according to embodiments of the present invention.

FIG. 10 is a graph illustrating internal pressure of a solder structure as a function of length of principal radii according to embodiments of the present invention.

FIGS. 13A-C are plan views illustrating steps of forming solder structures according to embodiments of the present invention.

DETAILED DESCRIPTION

The present invention now will be described more fully hereinafter with reference to the accompanying drawings, in which embodiments of the invention are shown. This invention may, however, be embodied in many different forms and should not be construed as limited to the embodiments set forth herein. Rather, these embodiments are provided so that this disclosure will be thorough and complete, and will fully convey the scope of the invention to those skilled in the art.

In the drawings, the thickness of layers and regions are exaggerated for clarity. It will also be understood that when an element such as a layer, region or substrate is referred to as being on another element, it can be directly on the other element or intervening elements may also be present. In contrast, if an element such as a layer, region or substrate is referred to as being directly on another element, then no other intervening elements are present. As used herein, the term and/or includes any and all combinations of one or more of the associated listed items.

Furthermore, relative terms, such as beneath, upper, and/or lower may be used herein to describe one element's relationship to another element as illustrated in the figures. It will be understood that relative terms are intended to encompass different orientations of the device in addition to the orientation depicted in the figures. For example, if the device in one of the figures is turned over, elements described as below other elements would then be oriented above the other elements. The exemplary term below, can therefore, encompass both an orientation of above and below.

It will be understood that although the terms first and second are used herein to describe various regions, layers and/or sections, these regions, layers and/or sections should not be limited by these terms. These terms are only used to distinguish one region, layer or section from another region, layer or section. Thus, a first region, layer or section discussed below could be termed a second region, layer or section, and similarly, a second region, layer or section could be termed a first region, layer or section without departing from the teachings of the present invention. Like numbers refer to like elements throughout.

The terminology used herein is for the purpose of describing particular embodiments only and is not intended to be limiting of the invention. As used herein, the singular forms "a", "an" and "the" are intended to include the plural forms as well, unless the context clearly indicates otherwise. It will be further understood that the terms "comprises" and/or "com-

prising," when used in this specification, specify the presence of stated features, integers, steps, operations, elements, and/or components, but do not preclude the presence or addition of one or more other features, integers, steps, operations, elements, components, and/or groups thereof.

Unless otherwise defined, all terms (including technical and scientific terms) used herein have the same meaning as commonly understood by one of ordinary skill in the art to which this invention belongs. It will be further understood that terms, such as those defined in commonly used dictionaries, should be interpreted as having a meaning that is consistent with their meaning in the context of the relevant art and will not be interpreted in an idealized or overly formal sense unless expressly so defined herein.

According to embodiments of the present invention, reservoir and pad geometries may provide bump overhang and increase a range of applications, and in particular applications with relatively fine pitch. In the analysis of Laplace-Young, at any point P on a surface S, the curvature of S at P can be represented by two orthogonal arcs or principal radii R1 and R2, as shown in FIG. 1.

If S represents an air-liquid interface, then the pressure difference across the surface is:

$$\Delta P = \gamma \left(\frac{1}{R_1} + \frac{1}{R_2} \right). \quad [1]$$

For a spherical liquid body, this reduces to:

$$\Delta P = \frac{2\gamma}{R}, \quad [2]$$

where γ is the surface tension difference across the interface. This pressure may also represent a potential energy of the surface. Since natural forces may tend to reduce energy, the liquid surface may tend to increase R1 and R2.

According to embodiments of the present invention, solder bumps may be placed (such as by plating) adjacent the edge of a die or substrate in a wafer, and the wafer including the die or substrate may be diced or sawed to singulate the die or substrate. More particularly, a die may include a plurality of integrated circuits (such as transistors, resistors, capacitors, diodes, inductors, etc.) therein and a wafer may include a plurality of such die. The solder bumps on the die can then be melted (after singulating the die) to form solder bump structures extending beyond the edge of the die or substrate, and to cause the solder bump structures to touch and wet to pads on a mating substrate oriented at an angle to the edge of the die or substrate. The mating substrate, for example, may be another integrated circuit device and/or a printed circuit board.

In addition, an overhang of solder may be increased to accommodate uncertainty in the width of a dicing kerf after dicing. Moreover, pitch or center-to-center spacing of these solder bumps on a die may be reduced to increase the number of interconnections along the edge of the die or substrate. A formation of extraneous solder structures due to inherent instabilities and/or perturbations of the manufacturing processes may also be reduced.

Structures according to embodiments of the present invention are discussed below with respect to FIGS. 2A-I. In each of FIGS. 2A-I, there are provided corresponding cross-sectional

5

tional and top views of solder bump structures according to embodiments of the present invention.

A super-hemispheric bump geometry is shown in FIG. 2A. The bump **21** circumference (outer circle) is concentric with the bump pad **23** (inner circle). A relatively large volume of solder may be required for this approach. The solder bump **21** may be formed using a sequence including solder plating through a mask, followed by dicing, followed by solder reflow. Because the solder reflow follows dicing, interference of the plated solder deposit with the dicing blade can be reduced, yet the solder may overhang the edge of the die (separated by dicing) after reflow. To deposit enough solder to create the super-hemisphere, the plating template photoresist and the plated solder deposit may need to be very thick. The thick photoresist and plating may result in significant cost, throughput, yield, and pitch constraints. A super-hemispheric bump is illustrated in FIG. 3. In alternatives, the solder bump **21** may be formed, for example, using evaporation, jetting, and/or paste.

According to embodiments of the present invention illustrated in FIGS. 2A and 3, a plurality of solder bumps **21** may be plated on respective bump pads **23** along an edge of an integrated circuit die before dicing the die from a wafer including a plurality of die. The originally plated solder may be substantially cylindrical (before reflow) so that the plated solder does not extend significantly beyond the respective bump pad **23** before reflow. Accordingly, the die can be singulated before reflow without significantly interfering with the plated solder bump. After dicing, the solder bump **21** can be subjected to reflow so that the reflowed solder bump **21** extends beyond the bump pad **23** by an overhang distance **D**. By providing that the overhang distance **D** is greater than a distance between the edge of bump pad **23** after reflow, the bump may contact a pad on another substrate at the edge of the die having the solder bump **23** thereon.

In FIG. 2B, the solder bump **31** is directionally offset from the pad **33** to increase the overhang **D**. This offset may be possible if the solder can wet the side of the pad, which means the pad must have significant thickness and must be selectively wettable on one side. Selective wetting may be possible through selective oxidation or coating, the selective removal of oxide on the wetted side, or directional resist removal. However, the thickness of the solder deposit may be substantial and the cost may be high, while the control of directional wetting may be challenging.

In FIG. 2C, a reservoir of solder is provided in the form of a narrow elongated region **41** connected to the bump pad **43**. Differential pressure in the molten solder **45** may cause the solder in the reservoir to flow to the bump pad during reflow. A thickness requirement for the plated solder may thus be reduced, and/or an overhang distance **D** may be increased. Accordingly, cost may be reduced, and throughput may be increased. Solder reservoirs are discussed in greater detail in U.S. Pat. No. 6,388,203, the disclosure of which is hereby incorporated herein in its entirety by reference.

FIG. 2D is a more realistic representation of the structure of FIG. 2C. Here the tendency of liquid solder to reduce surface energy by increasing the radii of curvature may result in a pronounced meniscus **51** (neck) at the transition from the reservoir **53** to the bump pad **55** (see FIG. 6). This may have two effects. First, a relatively large volume of solder may be trapped in the meniscus **51**. Second, a radius of curvature of the bump **57** may increase along the diameter aligned to the point of connection between reservoir and pad. The first effect may negate some of the advantage of the reservoir and the second may reduce the overhang by increasing the effective diameter of the wetted pad. FIG. 4 shows a plan view of plated

6

solder on a circular bump pad and on a rectangular reservoir prior to reflow. FIGS. 5 and 6 show respective top and plan views of the solder of FIG. 4 after being subjected to reflow. The structures of FIGS. 5 and 6 correspond to those of FIG. 2D.

In FIG. 2E, attempts to increase the overhang **D** of solder bump **61** from pad **65** by simply increasing the volume may net little gain because the meniscus **63** on reservoir **67** may grow larger and the effective wetted diameter may increase. As shown in FIG. 7, increasing a solder volume may increase the size of meniscus **63** so that the overhang **D** does not increase significantly.

A size of the meniscus **71** (neck) can be reduced by changing the pressure differential, by either increasing the diameter of pad **73** or reducing the width of reservoir **75**, as shown in FIG. 2F. Increasing the diameter of pad **73** may affect the pitch and the volume of solder needed to achieve a given overhang **D** of solder bump **77**. Decreasing the width of reservoir **75** may decrease the volume of the reservoir. Both effects may be counter to the goal.

Increasing the pad diameter to reduce internal pressure and reducing pad diameter to increase overhang can be decoupled, as seen in the Laplace-Young equation. Recognition that the two principal radii are different allows the oval design of FIG. 2G. The radius of pad **81** parallel to the edge of the die can be relatively large so the internal pressure is lower and the meniscus **87** (neck) is smaller. The radius of pad **81** perpendicular to the die edge can be relatively narrow to increase the solder bump **85** overhang. Stated in other words, the pad **81** may have a length **L** parallel to the die edge that is greater than a width **W** perpendicular to the die edge. A geometry that exhibits different principal radii is the truncated circle or 'D' shaped pad shown in FIGS. 8 and 9.

Further improvement can be seen in FIG. 2H where the point of connection between the reservoirs **91** and the pad **93** has been moved to the sides of the pad **93**. Two reservoirs **91** may be used to retain symmetry. In this case, the reservoirs **91** may not significantly increase the diameter/width **W** of pad **93** (perpendicular to the die edge) so the overhang of solder bump **95** can be improved.

Since the liquid will not form a sharp angle, squaring the corners of pad **101** along the die edge as shown in FIG. 2I, may pull the solder **103** toward the pad edge, thus improving overhang **D** further. Reservoirs **105** may be provided at ends of the pad **101**.

These designs may work because the internal pressure may be dominated by the smaller of the two principal radii. FIG. 10 shows the internal pressure as the two radii are varied. It can be seen that the pressure may be substantially independent of the larger radii, if the radii are substantially different.

Guidelines for solder wettable pads, solder wettable reservoirs, and solder bumps according to some embodiments of the present invention are provided below.

1.) Reservoir Design

a. Relatively sharp interior angles may be provided.

- i. Relatively high surface tension liquids such as molten solder constrained to a two dimensional surface may tend to form a meniscus (a bridge or short cut) at an interior angle. Any chamfer of the corner may exacerbate the problem and may lead to extraneous bump formation.

b. Wide bights may be provided.

- i. A tendency to bridge across a bight (U-shaped section) of a reservoir path may depend on a width of the bight and a length of the meniscus. If the menisci of the two corners overlap there may be a possibility that they will merge and form a metastable bridge over the

- bight. Bights with openings wider than 2.5 times the radius of curvature may thus be provided.
- c. Narrow tributary mouths may be provided.
- i. Mouths of tributaries (where branches meet the main reservoir) may create localized regions of low pressure because both principal radii may be relatively large. The intersection may be kept narrow enough that the low pressure does not create a large upwelling that can become super-hemispheric resulting in a runaway situation. Both the tributary and the main reservoir may thus be narrowed by at least 20% at the mouth of tributaries.
- d. Spacing may heed a flow progression.
- i. As a reservoir soldershed drains, distant ends may drain first. Solder may build up at mouths of tributaries, creating temporary mounds of molten solder that may be relatively large. Since the wetting angles are relatively large, the drained ends may not merge with the mounds because the ends may have a relatively low profile.
- ii. Therefore, spacing between ends of a reservoir and other portions of the reservoir can be at reduced and/or minimum dimensions. Reservoir channels may require additional spacing to allow for the increase in width during flow. Tributary mouths may require further spacing to allow for the temporary expansion during reflow.
- e. Sluices may be flared.
- i. A timing of flow progression can be adjusted by introducing restrictions in a flow path. A flared narrowing in the reservoir may create a sluice that can slow a rate of fluid flow. A build-up of liquid at bends, tributary mouths, and other locations may thus be reduced and/or prevented.
- 2.) Pad Design
- a. Reservoir to pad edge angle may be acute to reduce any meniscus.
- b. Narrow dimension may be greater than the widest reservoir narrow dimension
- i. More particularly, a narrow pad dimension may be >10% larger than a widest reservoir narrow dimension.

FIG. 11 illustrates representative structures according to embodiments of the present invention. Here, a structure 55 Φ m (micron) wide, 225 Φ m (micron) long, and 20 Φ m (micron) thick may result in an overhang of 21 Φ m (micron). In FIG. 11, a solder bump 1101 on a first substrate 1103 (such as an integrated circuit die) may overhang an edge of the substrate 1103 for bonding with a pad of a second substrate 1107 (such as a printed circuit board, another integrated circuit die, etc.). Reservoirs 1109a-b may be coupled with opposite ends of the solder bump 1101, and the reservoirs may have one or more bends therein to reduce an amount of substrate space consumed. Moreover, one or both of the reservoirs may include a plurality of branches. For example, the reservoir 1109a may include branches 1109a' and 1109a", and the reservoir 1109b may include branches 1109b' and 1109b". In addition, one or more reservoirs and/or branches may include a flared sluice.

More particularly, solder may be plated to a uniform thickness in the reservoir and bump regions so that the plated solder in the bump region does not interfere when dicing the substrate from a wafer including the substrate. Once the substrate has been diced, the plated solder can be heated above its melting temperature so that solder flows from the reservoirs and branches thereof (1109a, 1109a', 1109a", 1109b, 1109b', and 1109b") to the bump 1101. Accordingly, the solder bump

1101 can expand laterally beyond the edge of the substrate 1103 for bonding with substrate 1107.

Structures according to additional embodiments of the invention are shown in FIG. 12. In FIG. 12, a solder bump 1201 on a first substrate 1203 may overhang an edge of the substrate 1203 (such as an integrated circuit die) for bonding with a pad 1205 of a second substrate 1207 (such as a printed circuit board, another integrated circuit die, etc.). Reservoirs 1209a-b may be coupled with opposite ends of the solder bump 1201, and the reservoirs may have one or more bends therein to reduce an amount of substrate space consumed. Moreover, one or both of the reservoirs may include a plurality of branches. For example, the reservoir 1209b may include branches 1209b' and 1209b". In addition, one or more reservoirs and/or branches may include a flared sluice.

More particularly, solder may be plated to a uniform thickness in the reservoir and bump regions so that the plated solder in the bump region does not interfere when dicing the substrate from a wafer including the substrate. Once the substrate has been diced, the plated solder can be heated above its melting temperature so that solder flows from the reservoirs and branches thereof (1209a, 1209b, 1209b', and 1209b") to the bump 1201. Accordingly, the solder bump 1201 can expand laterally beyond the edge of the substrate 1203 for bonding with substrate 1207.

FIGS. 13A-C are plan views illustrating steps of forming solder structures according to embodiments of the present invention. As shown in FIG. 13A, a plurality of microelectronic die 1301a-i (also referred to as substrates) may be formed on a semiconductor wafer 1303, and the microelectronic die 1301a-i may be separated by streets 1305. Each of the die 1301a-i, for example, may be an integrated circuit device including a plurality of electronic devices such as transistors, diodes, resistors, capacitors, inductors, etc. Moreover, a plurality of solder bumps 1307 may be formed on respective solder wettable pads (not shown) on the microelectronic die 1301a-i.

For example, a continuous seed layer may be formed across the wafer 1303, and the seed layer may be used as a plating electrode to selectively electroplate the solder bumps 1307 through a plating mask or template. The plating mask or template and portions of the seed layer not covered by the solder bumps may then be removed. Portions of the seed layer remaining between respective solder bumps 1307 and die 1301a-i may make up the solder wettable pads. For example, the seed layer and the resulting solder wettable pads may include an adhesion layer (such as a layer of titanium, tungsten, chrome, and/or combinations thereof) and a conduction layer (such as a layer of copper). Each of the solder wettable pads may also include a conductive barrier layer (such as a layer of nickel, platinum, palladium, and/or combinations thereof) which may be provided as a portion of a continuous seed layer or which may be electroplated prior to electroplating the solder bumps.

As shown in FIG. 13A, the solder bumps 1307 are maintained within edges of the respective die 1301a-i before separating the individual die from the wafer, and the die may be separated from the wafer 1303, for example, by sawing the wafer 1303 along streets 1305. Accordingly, the solder bumps do not interfere with sawing the wafer 1303, and the separated die 1301a of FIG. 13B may be provided with the solder bumps 1307 maintained inside edges of the die 1301a. Typically, a set back in the range of about 20 microns to about 200 microns may be provided between the solder bumps 1307 and the edge of the respective die 1301a-i.

After separating the die 1301a from the wafer 1303, the solder bumps may be heated to a reflow temperature so that

the solder bumps **1307'** extend laterally toward an edge of the die **1301a**. As shown in FIG. **13C**, the solder bumps **1307'** may extend to and/or beyond the edge of the die **1301a**. The solder wettable pads may be provided, for example, using structures discussed above with respect to FIGS. **2A-I**, **3-9**, **11**, and/or **12** to provide that solder bumps **1307'** extends laterally to and/or beyond the edge of the substrate after reflow. The solder bumps **1307'** can thus provide interconnection to another substrate (such as another die and/or printed circuit board) provided along an edge thereof. Connection to another substrate is discussed, for example, in U.S. Pat. No. 5,963,793, the disclosure of which is hereby incorporated herein in its entirety by reference.

According to some embodiments of the present invention, the solder bumps **1307** may be set back from a nearest edge of the die **1301a** by at least about 20 microns before reflow so that the solder bumps do not interfere with separation of the die **1301a** from the wafer **1303**. After reflow, the solder bumps **1307'** may extend toward the nearest edge of the die **1301a**. More particularly, the solder bumps **1307'** may extend at least to within about 10 microns from the edge of the die **1301a** after reflow. According to some embodiments, the solder bumps **1307'** may extend at least to within about 5 microns of the edge of the die **1301a** after reflow. As shown in FIGS. **13B** and **13C**, the solder bumps **1307** may be offset from an edge of the die **1301a** before reflow by at least about 20 microns, and the solder bumps **1307'** may extend to and/or beyond the edge of the die **1301a** after reflow.

As used herein, the term solder wettable pad refers to one or more conductive layers provided between a solder bump and a substrate. A solder wettable pad may include an adhesion layer (such as a layer of titanium, tungsten, chrome, and/or combinations thereof), a conduction layer (such as a layer of copper), and/or a barrier layer (such as a layer of nickel, platinum, palladium, and/or combinations thereof). A solder bump may be a bump of one or more different solder materials. For example, a solder bump may include one or more of a single element, binary, ternary, and/or higher order solder; such as a lead-tin solder, a lead-bismuth solder, a lead-indium solder, a lead free solder, a tin-silver solder, a tin-silver-copper solder, an indium-tin solder, an indium-gallium solder, a gallium solder, an indium-bismuth solder, a tin-bismuth solder, an indium-cadmium solder, bismuth-cadmium solder, tin-cadmium, etc. Accordingly, a solder wettable pad may provide a surface that is wettable to a solder bump wherein the solder wettable surface of the solder wettable pad and the solder bump comprise different materials.

While the present invention has been particularly shown and described with reference to embodiments thereof, it will be understood by those skilled in the art that various changes in form and details may be made therein without departing from the spirit and scope of the invention as defined by the appended claims and their equivalents.

That which is claimed is:

1. A solder structure comprising:

a substrate;

a solder wettable pad on the substrate adjacent an edge of the substrate, the solder wettable pad having a length parallel to the edge of the substrate and a width perpendicular to the edge of the substrate wherein the length parallel to the edge of the substrate is greater than the width perpendicular to the edge of the substrate, and wherein the solder wettable pad is set back from the edge of the substrate by at least 20 microns; and

a solder bump on the solder wettable pad wherein the solder bump extends laterally from the solder wettable

pad toward the edge of the substrate at least to within 10 microns of the edge of the substrate.

2. A solder structure according to claim **1** wherein the solder bump extends laterally from the solder wettable pad beyond the edge of the substrate.

3. A solder structure according to claim **1** wherein the solder bump extends laterally from the solder wettable pad to the edge of the substrate.

4. A solder structure according to claim **1** further comprising:

a solder wettable reservoir connected to the solder wettable pad, the solder wettable reservoir having a width at a connection with the solder wettable pad that is less than the width of the solder wettable pad.

5. A solder structure according to claim **4** wherein the width of the solder wettable pad is at least 10% greater than a greatest width of the solder wettable reservoir.

6. A solder structure according to claim **4** wherein an angle of a junction between the solder wettable pad and the solder wettable reservoir comprises an acute angle.

7. A solder structure according to claim **4** wherein the solder wettable reservoir includes a flared narrowing therein.

8. A solder structure according to claim **4** wherein the solder wettable reservoir includes a two branches that join at a junction with the junction being between the two branches and the connection with the solder wettable pad, wherein each branch narrows by at least 20% at the junction therebetween.

9. A solder structure according to claim **4** wherein the solder wettable reservoir includes a bight therein wherein the bight includes an opening at least 2.5 times a radius of curvature of the bight.

10. A solder structure according to claim **1** further comprising:

first and second solder wettable reservoirs connected to opposing ends of the solder wettable pad.

11. A solder structure according to claim **10** wherein the connections of the solder wettable reservoirs to the solder wettable pad are separated by the length of the solder wettable pad parallel to the edge of the substrate.

12. A solder structure according to claim **10** wherein portions of the first and second solder wettable reservoirs connected to the solder wettable pad have respective widths that are less than the width of the solder wettable pad.

13. A solder structure according to claim **1** further comprising:

a second substrate adjacent the edge of the first substrate, wherein the first and second substrates are not parallel and wherein the solder bump is connected to the second substrate.

14. A solder structure according to claim **13** wherein the first and second substrates are substantially orthogonal with respect to each other.

15. A solder structure according to claim **1** wherein the substrate comprises a microelectronic die.

16. A solder structure according to claim **1** wherein the solder wettable pad and the solder bump comprise different materials.

17. A solder structure according to claim **1** wherein the solder bump has a length parallel to the edge of the substrate and a width perpendicular to the edge of the substrate wherein the length of the solder bump parallel to the edge of the substrate is greater than the width of the solder bump perpendicular to the edge of the substrate.

18. A solder structure according to claim **17** wherein the solder wettable pad is set back from the edge of the substrate wherein the substrate includes solder non-wettable portions that are exposed between the solder wettable pad and the edge

11

of the substrate, and wherein a distance between the solder bump and the solder non-wettable portions of the substrate increases with increasing distance from the solder wettable pad toward the edge of the substrate.

19. A solder structure according to claim 1, wherein the solder wettable pad and the solder bump comprise different materials, wherein the solder bump is directly on the solder wettable pad, and wherein a contact area between the solder bump and the solder wettable pad has a length parallel to the edge of the substrate that is greater than a width perpendicular to the edge of the substrate.

20. A solder structure according to claim 1, wherein the solder wettable pad comprises a first solder wettable pad and wherein the solder bump comprises a first solder bump, the solder structure further comprising:

a second solder wettable pad on the substrate adjacent the edge of the substrate, the second solder wettable pad having a length parallel to the edge of the substrate and a width perpendicular to the edge of the substrate wherein the length parallel to the edge of the substrate is greater than the width perpendicular to the edge of the substrate, and wherein the first and second solder wettable pads are spaced apart; and

a second solder bump on the second solder wettable pad wherein the second solder bump extends laterally from the second solder wettable pad toward the edge of the substrate at least to within 10 microns of the edge of the substrate, and wherein the first and second solder bumps are spaced apart.

21. A solder structure comprising:

a substrate;

a solder wettable pad on the substrate adjacent an edge of the substrate, the solder wettable pad having a length parallel to the edge of the substrate and a width perpendicular to the edge of the substrate wherein the length parallel to the edge of the substrate is greater than the width perpendicular to the edge of the substrate, and wherein the solder wettable pad is set back from the edge of the substrate; and

a solder bump on the solder wettable pad wherein the solder bump extends laterally from the solder wettable pad beyond the edge of the substrate.

22. A solder structure according to claim 21 further comprising:

at least one solder wettable reservoir connected to the solder wettable pad, the solder wettable reservoir having a width at a connection with the solder wettable pad that is less than the width of the solder wettable pad.

23. A solder structure according to claim 21 further comprising:

first and second solder wettable reservoirs connected to opposing ends of the solder wettable pad wherein the connections of the solder wettable reservoirs to the solder wettable pad are separated by the length of the solder wettable pad parallel to the edge of the substrate.

24. A solder structure according to claim 23 wherein portions of the first and second solder wettable reservoirs connected to the solder wettable pad have respective widths that are less than the width of the solder wettable pad.

25. A solder structure according to claim 21 further comprising:

a second substrate adjacent the edge of the first substrate, wherein the first and second substrates are not parallel and wherein the solder bump is connected to the second substrate.

26. A solder structure according to claim 21 wherein the substrate comprises a microelectronic die.

12

27. A solder structure according to claim 21 wherein the solder bump has a length parallel to the edge of the substrate and a width perpendicular to the edge of the substrate wherein the length of the solder bump parallel to the edge of the substrate is greater than the width of the solder bump perpendicular to the edge of the substrate.

28. A solder structure according to claim 27 wherein the solder wettable pad is set back from the edge of the substrate wherein the substrate includes solder non-wettable portions that are exposed between the solder wettable pad and the edge of the substrate, and wherein a distance between the solder bump and the solder non-wettable portions of the substrate increases with increasing distance from the solder wettable pad toward the edge of the substrate.

29. A solder structure according to claim 21, wherein the solder wettable pad and the solder bump comprise different materials, wherein the solder bump is directly on the solder wettable pad, and wherein a contact area between the solder bump and the solder wettable pad has a length parallel to the edge of the substrate that is greater than a width perpendicular to the edge of the substrate.

30. A solder structure according to claim 21, wherein the solder wettable pad comprises a first solder wettable pad and wherein the solder bump comprises a first solder bump, the solder structure further comprising:

a second solder wettable pad on the substrate adjacent the edge of the substrate, the second solder wettable pad having a length parallel to the edge of the substrate and a width perpendicular to the edge of the substrate wherein the length parallel to the edge of the substrate is greater than the width perpendicular to the edge of the substrate, wherein the second solder wettable pad is set back from the edge of the substrate, and wherein the first and second solder wettable pads are spaced apart; and

a second solder bump on the second solder wettable pad wherein the second solder bump extends laterally from the second solder wettable pad beyond the edge of the substrate, and wherein the first and second solder bumps are spaced apart.

31. A solder structure comprising:

a first substrate;

a solder wettable pad on the first substrate adjacent an edge of the first substrate, the solder wettable pad having a length parallel to the edge of the first substrate and a width perpendicular to the edge of the first substrate wherein the length parallel to the edge of the first substrate is greater than the width perpendicular to the edge of the first substrate, and wherein the solder wettable pad is set back from the edge of the substrate;

a solder bump on the solder wettable pad; and

a second substrate adjacent the edge of the first substrate, wherein the first and second substrates are not parallel and wherein the solder bump is connected to the second substrate.

32. A solder structure according to claim 31 wherein the first and second substrates are substantially orthogonal with respect to each other.

33. A solder structure according to claim 31 the solder wettable pad is set back from the edge of the substrate by at least 20 microns and wherein the solder bump extends laterally from the solder wettable pad toward the edge of the substrate at least to within 10 microns of the edge of the first substrate.

34. A solder structure according to claim 31 wherein the first substrate comprises a microelectronic die.

13

35. A solder structure according to claim 31 wherein the solder wettable pad and the solder bump comprise different materials.

36. A solder structure according to claim 31 further comprising:

a solder wettable reservoir connected to the solder wettable pad, the solder wettable reservoir having a width at a connection with the solder wettable pad that is less than the width of the solder wettable pad.

37. A solder structure according to claim 36 wherein the width of the solder wettable pad is at least 10% greater than a greatest width of the solder wettable reservoir.

38. A solder structure according to claim 31 wherein the solder bump has a length parallel to the edge of the substrate and a width perpendicular to the edge of the substrate wherein the length of the solder bump parallel to the edge of the substrate is greater than the width of the solder bump perpendicular to the edge of the substrate.

39. A solder structure according to claim 38 wherein the solder wettable pad is set back from the edge of the substrate wherein the substrate includes solder non-wettable portions that are exposed between the solder wettable pad and the edge of the substrate, and wherein a distance between the solder bump and the solder non-wettable portions of the substrate increases with increasing distance from the solder wettable pad toward the edge of the substrate.

14

40. A solder structure according to claim 31, wherein the solder wettable pad and the solder bump comprise different materials, wherein the solder bump is directly on the solder wettable pad, and wherein a contact area between the solder bump and the solder wettable pad has a length parallel to the edge of the substrate that is greater than a width perpendicular to the edge of the substrate.

41. A solder structure according to claim 31, wherein the solder wettable pad comprises a first solder wettable pad and wherein the solder bump comprises a first solder bump, the solder structure further comprising:

a second solder wettable pad on the second first substrate adjacent the edge of the first substrate, the second solder wettable pad having a length parallel to the edge of the first substrate and a width perpendicular to the edge of the first substrate wherein the length parallel to the edge of the first substrate is greater than the width perpendicular to the edge of the first substrate, and wherein the first and second solder wettable pads are spaced apart; and

a second solder bump on the second solder wettable pad wherein the second solder bump is connected to the second substrate, and wherein the first and second solder bumps are spaced apart.

* * * * *