

US007651278B2

(12) **United States Patent**
Kiani et al.

(10) **Patent No.:** **US 7,651,278 B2**
(45) **Date of Patent:** **Jan. 26, 2010**

(54) **MODULAR FIBER OPTIC CONNECTOR SYSTEM**

(75) Inventors: **Sepehr Kiani**, Watertown, MA (US);
Richard F. Roth, Brookline, NH (US)

(73) Assignee: **Amphenol Corporation**, Wallingford, CT (US)

(*) Notice: Subject to any disclaimer, the term of this patent is extended or adjusted under 35 U.S.C. 154(b) by 0 days.

(21) Appl. No.: **11/907,064**

(22) Filed: **Oct. 9, 2007**

(65) **Prior Publication Data**

US 2008/0037938 A1 Feb. 14, 2008

Related U.S. Application Data

(62) Division of application No. 10/744,050, filed on Dec. 23, 2003, now Pat. No. 7,290,941.

(51) **Int. Cl.**

G02B 6/36 (2006.01)

G02B 6/38 (2006.01)

(52) **U.S. Cl.** **385/78; 385/71**

(58) **Field of Classification Search** None
See application file for complete search history.

(56) **References Cited**

U.S. PATENT DOCUMENTS

5,408,557 A 4/1995 Hsu et al.

5,563,978 A 10/1996 Kawahara et al.

5,719,977 A *	2/1998	Lampert et al.	385/60
5,796,894 A	8/1998	Csipkes et al.		
6,371,660 B1	4/2002	Roehrs et al.		
6,456,774 B1	9/2002	Lin et al.		
6,461,052 B1 *	10/2002	Hines et al.	385/53
6,652,153 B2 *	11/2003	Bates et al.	385/59
6,709,165 B2 *	3/2004	De Marchi	385/55
6,715,930 B2	4/2004	McBride		
6,776,645 B2	8/2004	Roth et al.		
6,832,858 B2	12/2004	Roth et al.		
6,913,392 B2 *	7/2005	Grzegorzewska et al.	385/60
7,011,454 B2 *	3/2006	Caveney et al.	385/87
2003/0044127 A1	3/2003	Roth et al.		
2005/0135752 A1	6/2005	Kiani et al.		

* cited by examiner

Primary Examiner—Omar Rojas

(74) *Attorney, Agent, or Firm*—Blank Rome LLP

(57) **ABSTRACT**

An optical fiber interconnection system with a small number of modular components that can be configured for simple construction in many configurations. The system includes connector housings. Optical fibers are installed into the housings on ferrule carriers. The housings are brought together in adapters. Different styles of adapters are available for different applications, such as panel or backplane configurations. However, the same housing and ferrule carriers can be used in any style of adapter. Also, different ferrule carriers are provided for single fiber ferrules and multi-fiber ferrules. Either style of ferrule carrier can be used in a housing and adapter. A ferrule carrier for single fiber ferrules can be modified to provide fine alignment features with the addition of a cap, allowing the same style ferrule carrier to be used in both halves of a mated connector assembly.

15 Claims, 8 Drawing Sheets

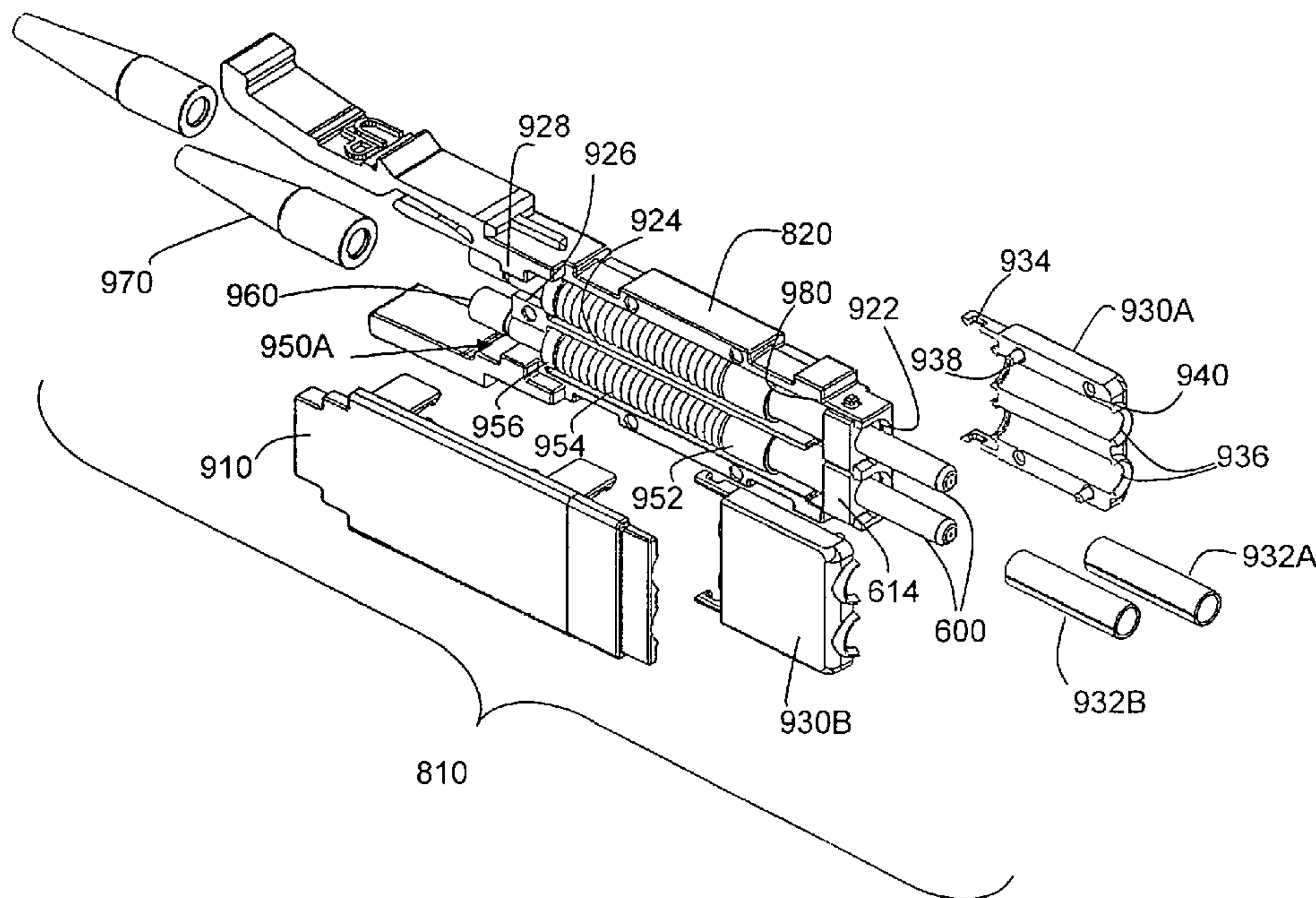

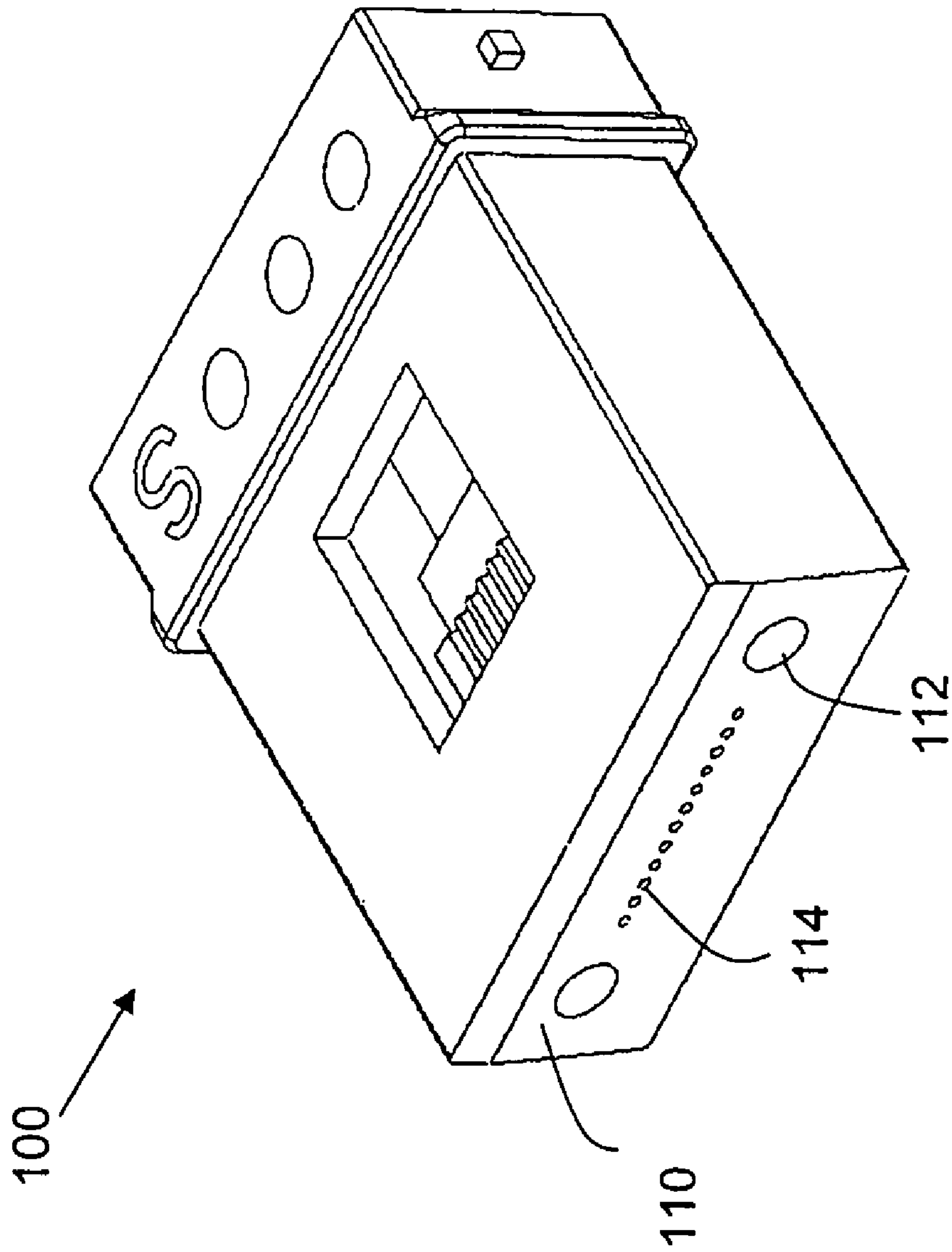

FIG. 1
(prior art)

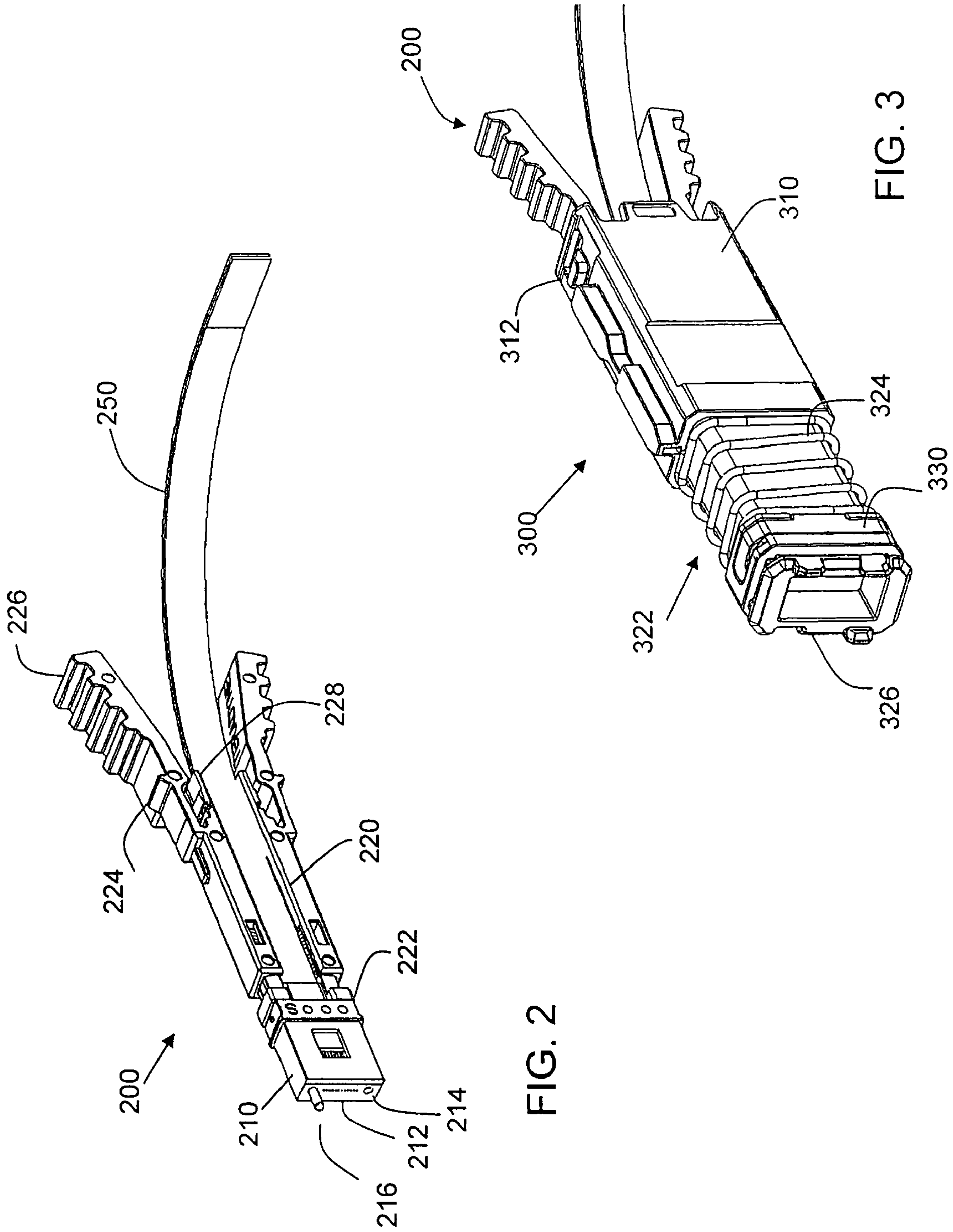

FIG. 2

FIG. 3

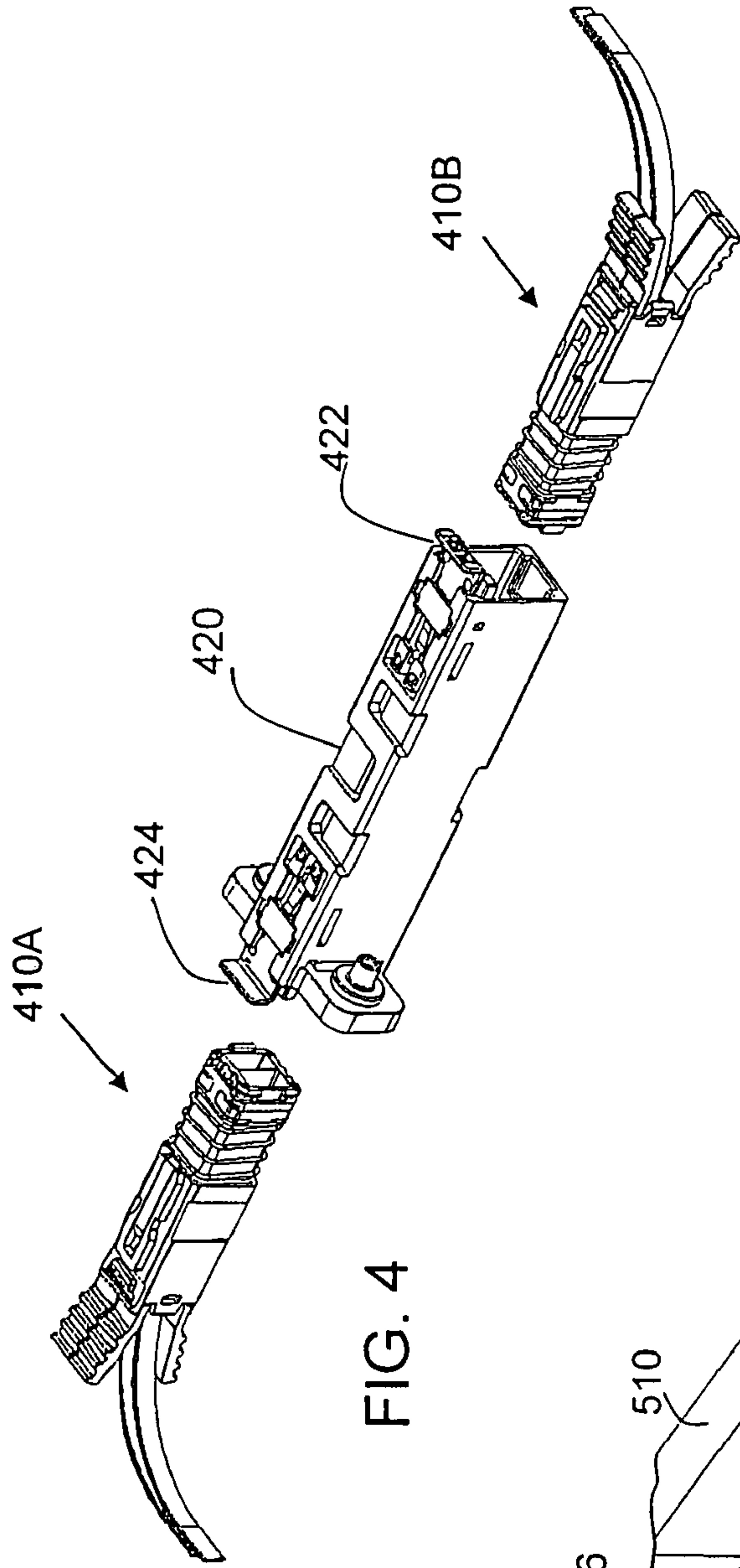

FIG. 4

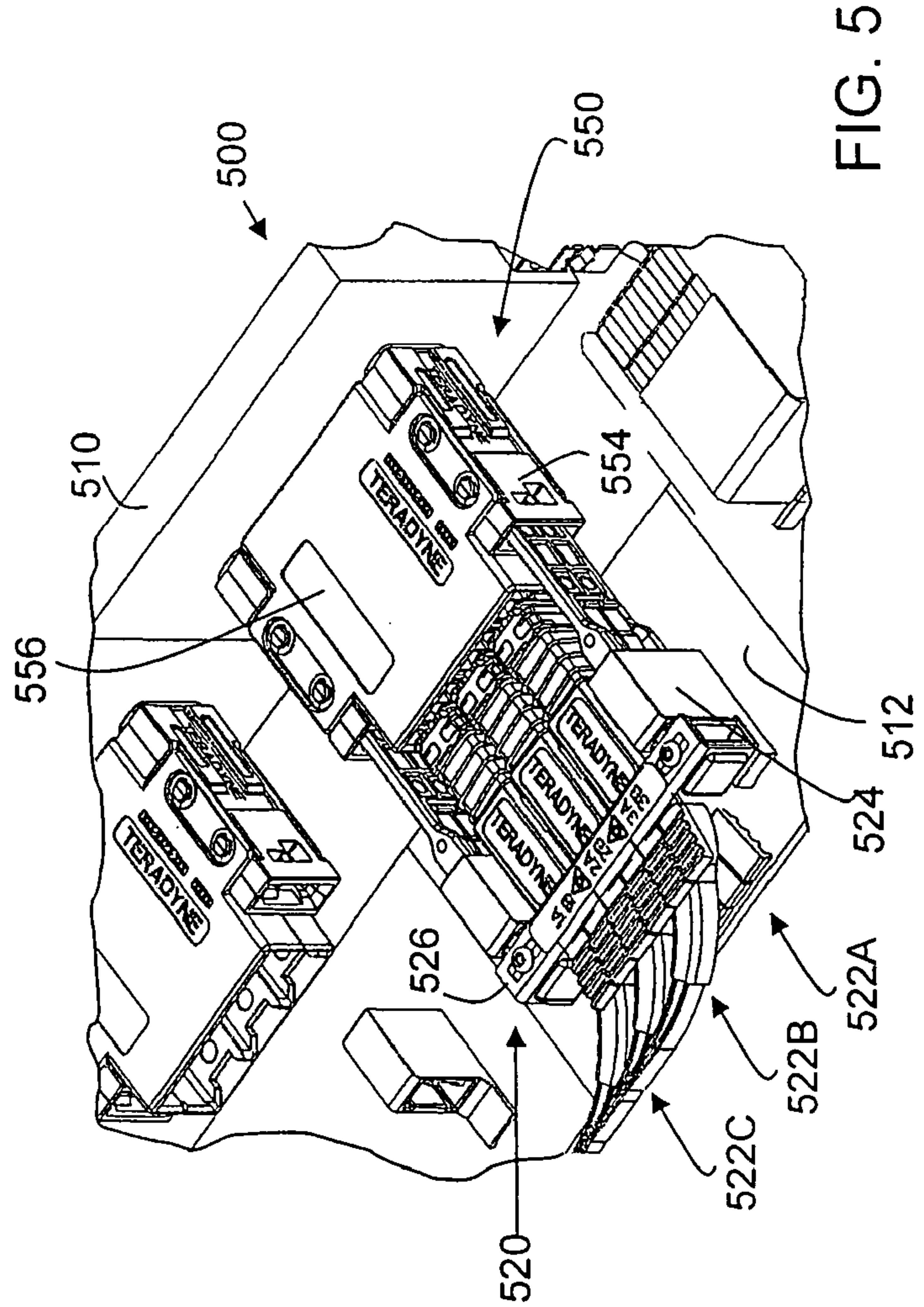

FIG. 5

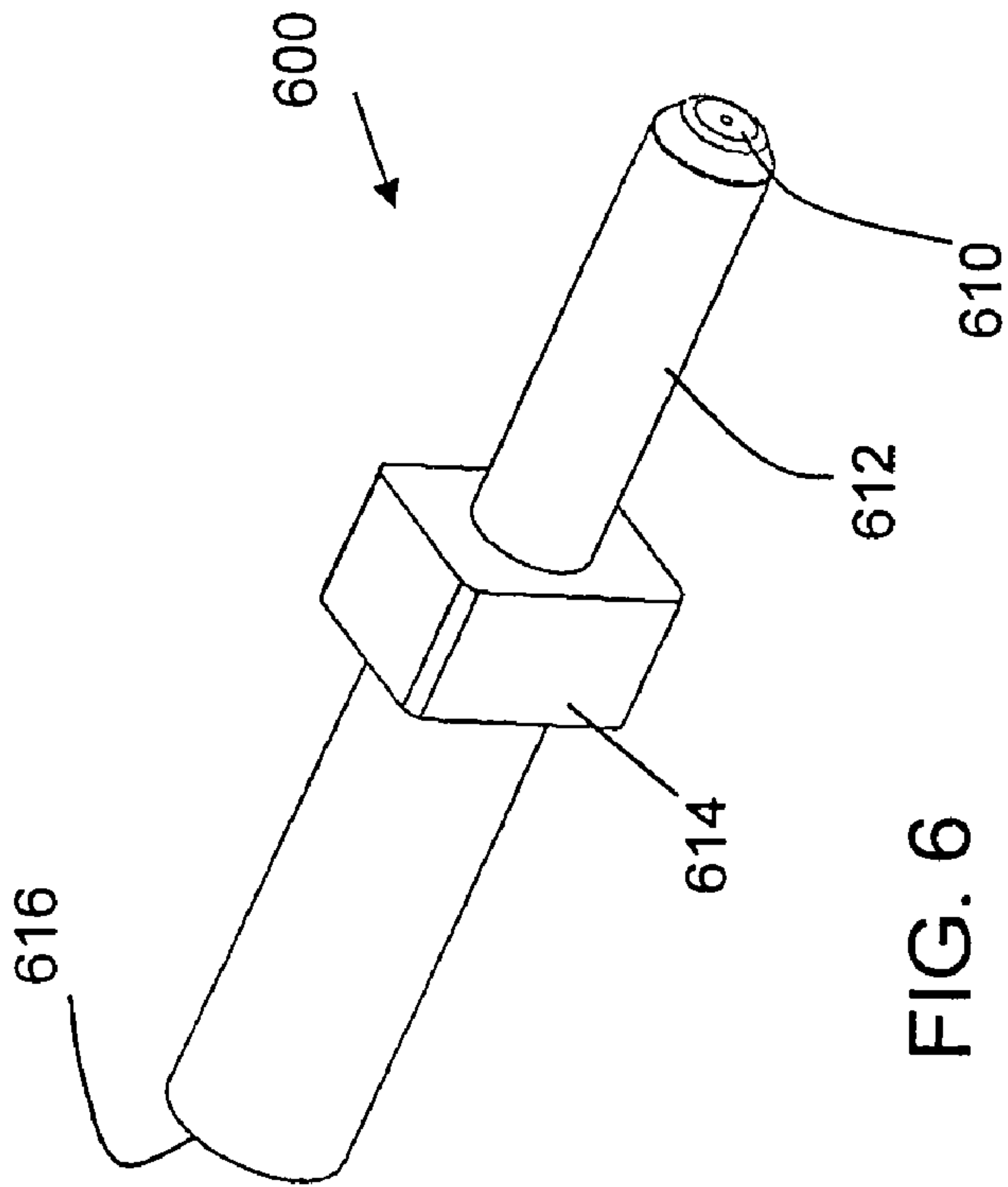

FIG. 6
(prior art)

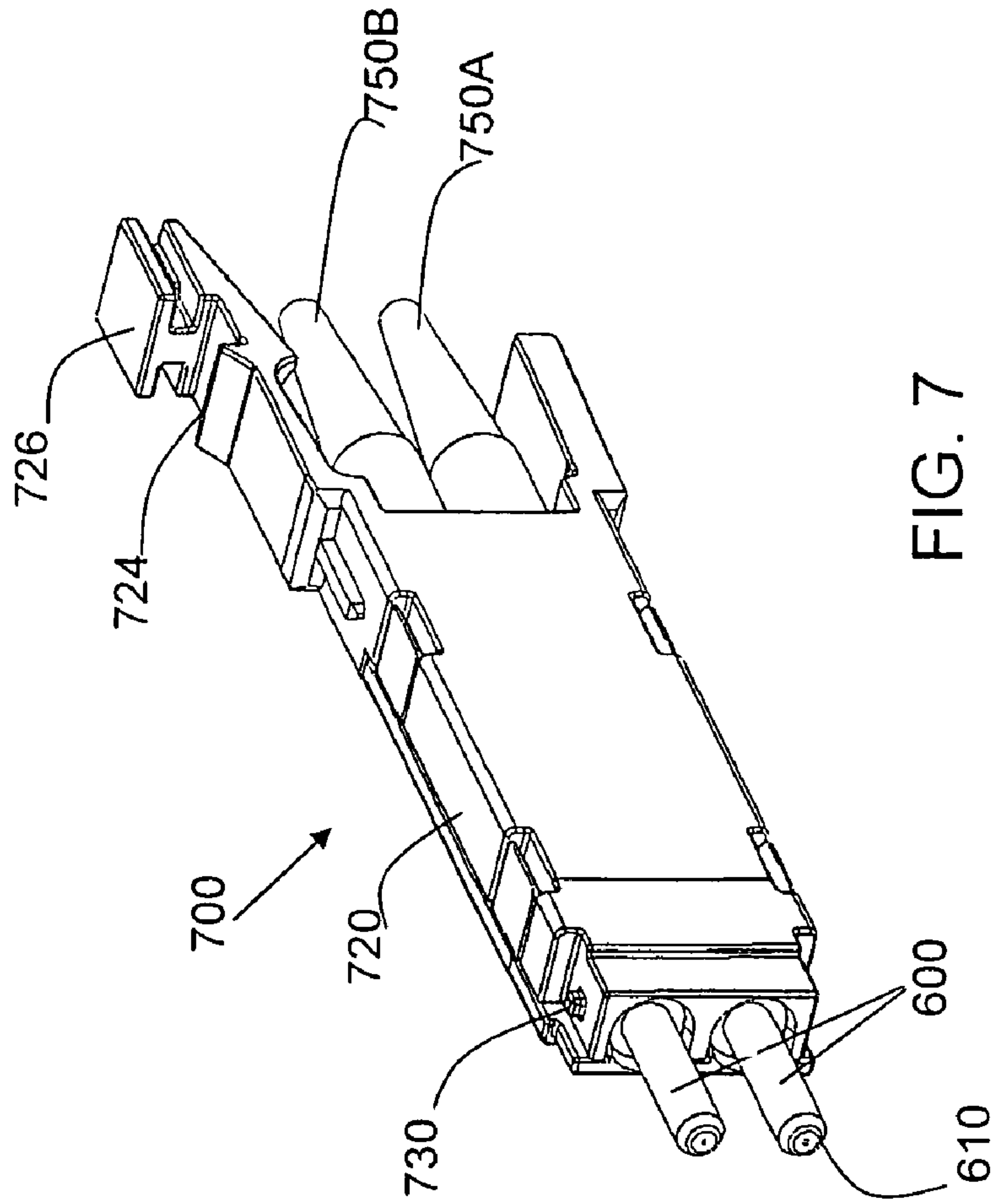
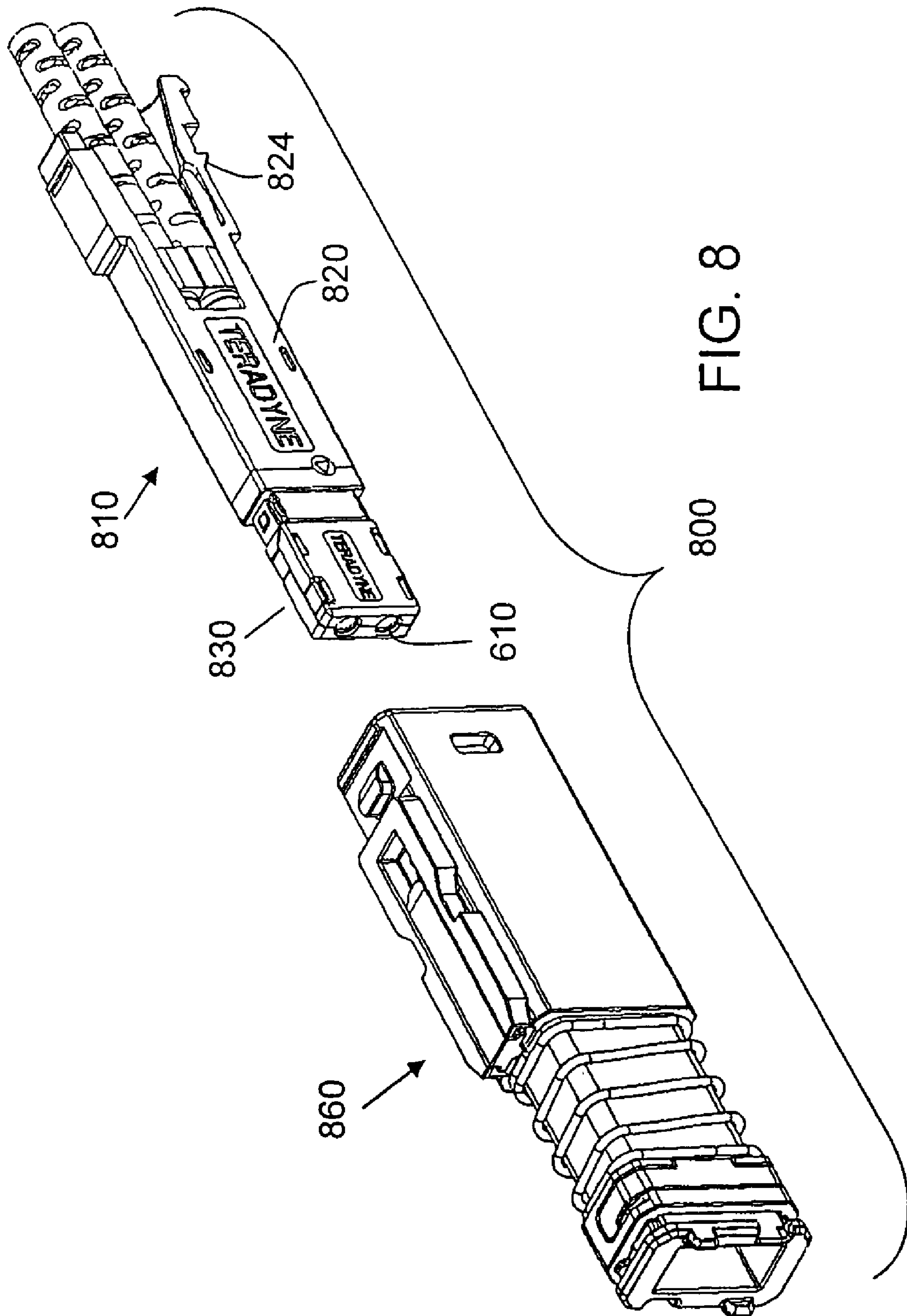

FIG. 7



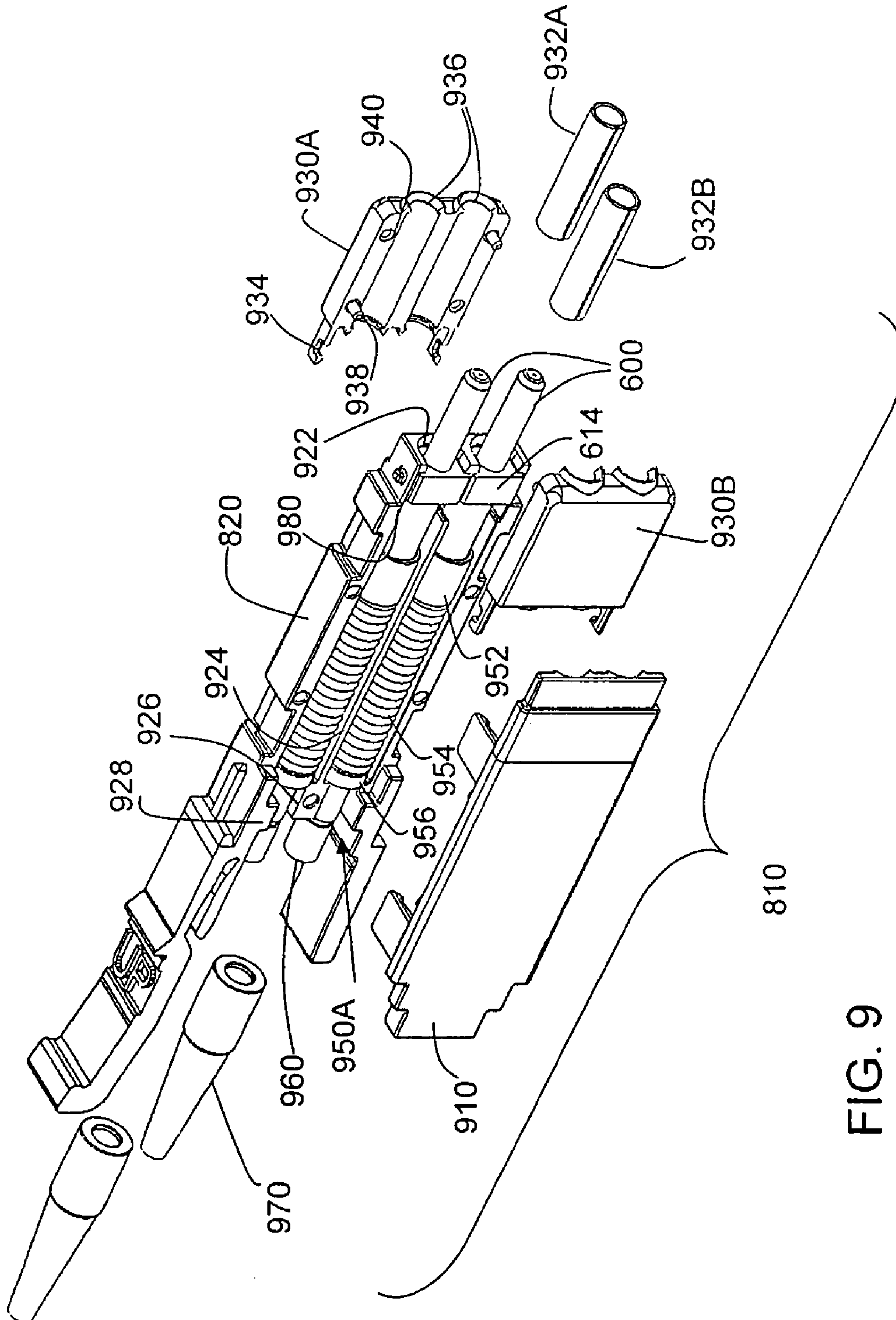

FIG. 9

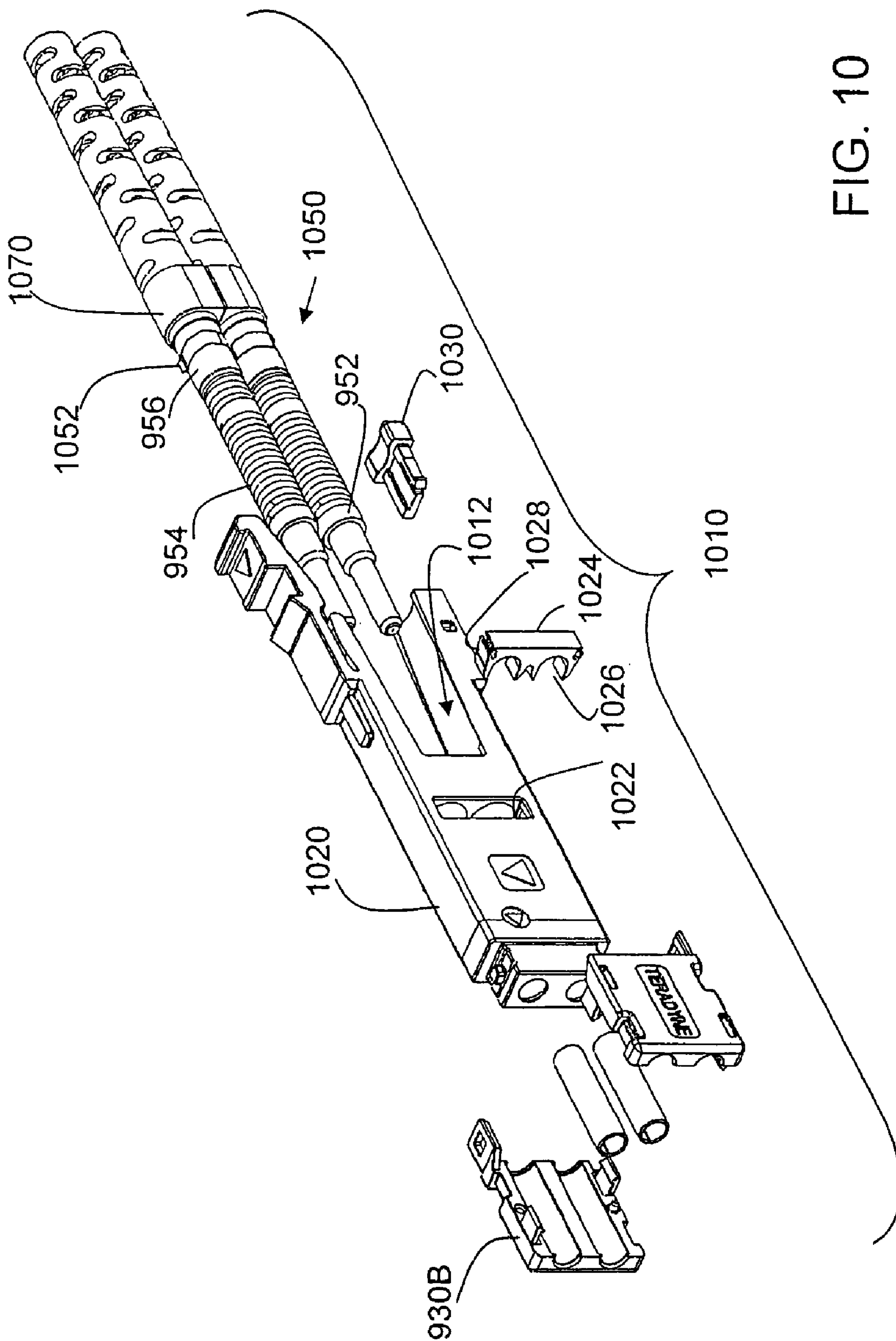

FIG. 10

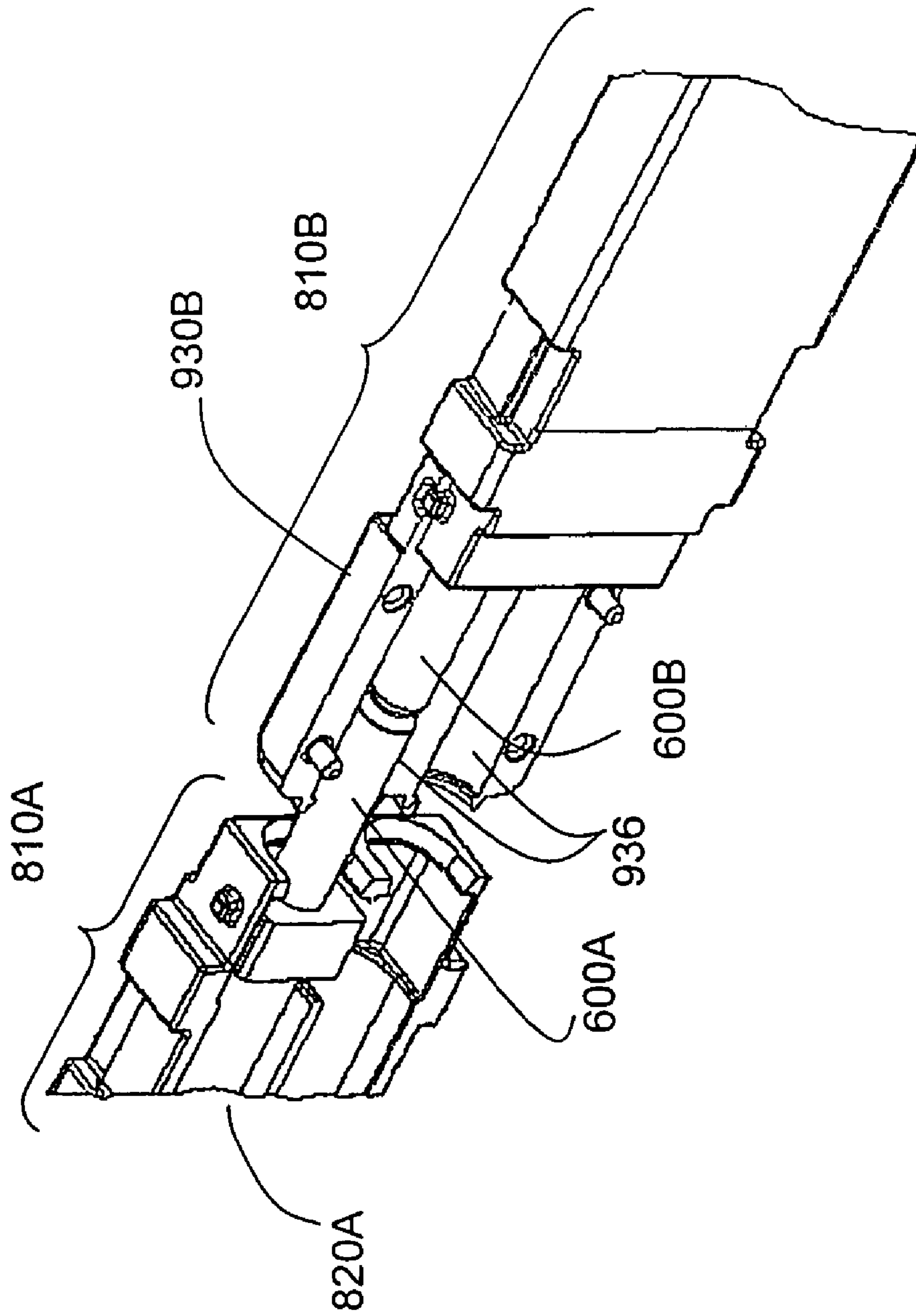

FIG. 11

MODULAR FIBER OPTIC CONNECTOR SYSTEM

CROSS-REFERENCE TO RELATED APPLICATION

This application is a divisional of U.S. patent application Ser. No. 10/744,050, filed Dec. 23, 2003, now U.S. Pat. No. 7,290,941 which is incorporated by reference herein.

BACKGROUND OF INVENTION

1. Field of Invention

This invention relates generally to electronic systems and more specifically to electronic systems using optical fibers to carry data between components of the system.

2. Discussion of Related Art

Many types of electronic systems are known. Common examples of electronic systems are computers, routers and telecommunications switches. Complex electronic systems have long been built as subassemblies that are then integrated into an overall system. Integration requires that data be passed between subassemblies.

Traditionally, integration of subassemblies has included making connections for electrical signals to carry data between the subassemblies. In some systems, printed circuit boards, sometimes called backplanes, are used to carry electrical signals between subassemblies. Backplanes are usually built as printed circuit boards. Conductive traces within the board carry electrical signals and electrical connectors attached to the board allow subassemblies to be connected to those traces.

In some instances, subassemblies are also built on printed circuit boards, called daughter cards. The conductive traces on the daughter cards interconnect electronic components mounted on the board. The traces also connect those components to connectors on the daughter card. The daughter card connectors mate with backplane connectors to allow the electronic circuitry on the daughter card to pass information in the form of electrical signals through the backplane to other subassemblies connected to the backplane. Where interconnections are made through a backplane, all of the subassemblies to be connected together are usually mounted in one housing.

In other instances, some electronic systems are made up of subassemblies that are contained in separate housings. The system might be too big to fit in a single enclosure or might require subassemblies located in physically separate locations. For example, data storage farms are made of interconnected storage units because it is likely that one unit containing all the necessary circuitry would be too large to easily fit within a single housing. Routers and switches in networks are made as separate pieces to allow the network to span a wide geographic range. A system also might be manufactured as separate components as a matter of convenience. For example, a system might be made from modules to allow systems of many different sizes to be constructed by integrating different numbers of modules.

Where systems are assembled from separate components, cables are often used to interconnect the components. Electronic components that are intended to be integrated into a much larger system often have “panels” or “bulkheads” to which cables interconnecting the subsystems can be connected.

Often, the panel on a subassembly contains electrical connectors. Inside the subassembly, these connectors might be connected to backplanes or daughter cards or otherwise tied

into the system. On the outside of the subassembly, the connectors are shaped to receive connectors on the ends of cables. In this way, cables can be plugged into panels to interconnect the subassemblies.

As electronic systems became more powerful, the data rate between subassemblies increased. To carry more data, optical interconnections were often used. Rather than transmit data as electrical signals on conductors, optical interconnections transmit data as modulated light in a structure that acts as an optical waveguide—often an optical fiber. To facilitate the interconnection of subassemblies using optical fibers, optical connectors have been developed. Both backplane/daughter-card and panel type optical connectors are known.

Several problems exist with optical interconnections that do not exist with corresponding electrical connectors. One particular problem is that the optical fibers must be aligned with much higher precision than electrical conductors for optical connectors to reliably transmit signals.

Alignment in optical connectors is often achieved through the use of several levels of alignment mechanisms. At the most precise level, the fiber in both halves of the connector is held in ferrules. Ferrules are precision manufactured components that contain alignment features.

Early designs used single fiber ferrules. These ferrules are generally cylindrical, with the outer surface of the cylinder being the alignment feature. Alignment of the fibers was achieved by inserting the ferrules into opposite ends of a sleeve. The sleeve was also a precision component, ensuring that the faces of the ferrules would align inside the sleeve. Often, the sleeve was incorporated into an adapter and connectors holding the ferrules were plugged into both sides of the adapter.

Multi-fiber ferrules have also been developed, such as the MT ferrule. Alignment features in these ferrules include posts and holes. The fibers held in the ferrules are aligned when the posts of one ferrule are in the holes of another ferrule.

However, for the ferrules to align the fibers as two connectors are mated, the ferrules must first be aligned such that the posts engage with the holes. This level of alignment is often provided through a connector housing. The connector housings have features that, when interlocked, ensure that the ferrules will be aligned with sufficient precision.

Another level of alignment is often used to ensure the housings line up and also to hold the connectors together when mated. A device that provides this level of alignment is also called an adapter. In a simple form, an adapter can be a sleeve into which two connectors can be inserted from opposite directions. The sleeve forces the connector housings into alignment when they come together in the center of the sleeve. Latching features can be incorporated into the sleeve to hold the connector housings together.

An example of an optical connector system can be found in U.S. patent application Ser. No. 10/243,458, filed Sep. 13, 2002, entitled Techniques for Forming Fiber Optic Connections in an Modularized Manner; U.S. Patent Application 2003/0044127 filed Jul. 16, 2002 entitled Modular Fiber Optic Connection System; U.S. patent application Ser. No. 10/326,480 entitled Latch and Release System for a Connector, filed on Dec. 20, 2002, by Roth, et al. all of which are hereby incorporated by reference in their entirety.

The above referenced patents and applications describe optical interconnection systems that use multi-fiber ferrules, housings and adapters for alignment. The adapters used for the backplane/daughter card interconnection in some of the examples have several sleeves tied together in a row. Though ferrules that can simultaneously align multiple fibers are known, forming several housings into a connector assembly

3

allows even more connections to be made simultaneously for applications that require many connections.

Despite the development of multi-fiber ferrules, single fiber ferrules are still in use. Not all electronic systems require large numbers of optical fiber interconnects to be made at one time. A particular system simply might not require an exchange of a sufficiently large amount of data to justify a multi-fiber interconnect. And, single fiber interconnects often have different performance characteristics than multi-fiber interconnects. Single fiber connectors are more likely to be made with multimode fiber, which is larger than single mode fiber traditionally used in multi-fiber interconnects. Multimode fibers tend to exhibit less loss at mating interfaces than smaller single mode fibers.

For this reason, it will sometimes be preferable to create a connector with multiple single fibers for ferrules than to use one multifiber ferrule. There are tradeoffs between use of single fiber interconnection and multi-fiber interconnections, making some types more suitable for certain applications and others more suitable for other applications. Consequently, suppliers of optical fiber interconnection systems are required to stock or build many types of components to be able to meet the needs for any particular system.

We have recognized a significant advantage can be obtained by providing components of an optical interconnection system that can be flexibly assembled into many different configurations.

SUMMARY OF INVENTION

It is an object to provide an optical interconnection system that can be flexibly assembled into multiple configurations.

The foregoing and other objects are achieved in an optical interconnection system that employs a ferrule carrier inserted in a housing. In one embodiment, the housing can receive different types of ferrule carriers, with ferrule carriers adapted to hold ferrules that align either single fibers or multiple fibers.

In another embodiment, a ferrule carrier adapted to hold ferrules for aligning single fibers can be modified by the addition of an adapter member to allow two ferrule carriers of the same design to be aligned.

BRIEF DESCRIPTION OF DRAWINGS

The accompanying drawings, are not intended to be drawn to scale. In the drawings, each identical or nearly identical component that is illustrated in various figures is represented by a like numeral. For purposes of clarity, not every component may be labeled in every drawing. In the drawings:

FIG. 1 is a sketch of a prior art multi-fiber ferrule;

FIG. 2 is a sketch of a ferrule carrier holding the multi-fiber ferrule;

FIG. 3 is a sketch of the multi-fiber ferrule carrier of FIG. 2 in a housing;

FIG. 4 is a sketch of an adapter, such as might be used in a panel configuration, for aligning two optical connectors;

FIG. 5 is a sketch of an adapter, such as might be used in a backplane configuration, for aligning multiple optical connectors;

FIG. 6 is a sketch of a prior art single fiber ferrule;

FIG. 7 is a sketch of a ferrule carrier holding two single fiber ferrules as shown in FIG. 6;

FIG. 8 is a sketch of a ferrule carrier for single fiber ferrules and a housing;

FIG. 9 is an exploded view of the ferrule carrier of FIG. 8;

4

FIG. 10 is an exploded view of the ferrule carrier of FIG. 9 shown from a reverse angle;

FIG. 11 is a view of the interior alignment of single mode fibers using ferrule carriers as shown in FIG. 8.

DETAILED DESCRIPTION

This invention is not limited in its application to the details of construction and the arrangement of components set forth in the following description or illustrated in the drawings. The invention is capable of other embodiments and of being practiced or of being carried out in various ways. Also, the phraseology and terminology used herein is for the purpose of description and should not be regarded as limiting. The use of “including,” “comprising,” or “having,” “containing,” “involving,” and variations thereof herein, is meant to encompass the items listed thereafter and equivalents thereof as well as additional items.

FIG. 1 shows a multi-fiber ferrule **100**, as is known in the art. Ferrule **100** has a mating face **110**. Mating face **110** includes alignment features, such as holes **112**. Fiber ends project through holes **114**, that are precisely positioned relative to alignment holes **112**. In operation, ferrule **100** would be held within a connector. That connector would mate with another connector that included a similar ferrule. However, the mating connector would have complementary mating features. For example a mating ferrule might have alignment posts in place of holes **112**.

FIG. 2 shows a ferrule carrier assembly **200**. In use, a ferrule can be incorporated into a ferrule carrier assembly **200** for easy application into an optical connector. FIG. 2 shows an example of a ferrule mounted in a ferrule carrier.

As shown in FIG. 2, ferrule **210** has a mating face **212**. Alignment features in mating face **210** include a hole **214** and a post **216**. Ferrule **210** may mate with a similarly shaped ferrule, with the post of one ferrule aligning with the hole of the other. As with ferrule **100**, ends of optical fibers are positioned in the mating face of ferrule **210** relative to the alignment features.

Ferrule carrier **200** includes a support member **220**. Support member **220** might be in the shape of a frame or other suitable support.

Compliant member **222** is mounted to support member **220**. Preferably, the ferrule will have compliance relative to the support member **220**. Compliance ensures that, as two optical fiber connectors are pressed together for mating, the alignment features determine the final alignment of the ferrules. Compliance automatically corrects for misalignment of the connectors.

In FIG. 2, compliance is provided through a spring coupling (not numbered) between compliant member **222** and support member **220**.

Support member **220** also includes attachment features that can hold the ferrule carrier **200** in a housing. In the example of FIG. 2, the attachment features are shown as latches **224** on cantilevered beams extending from the support member.

Cantilevered beams include handles **226** that may be pressed to flex the cantilevered beams and release the latches **224** from a housing. Handles **226** also provide a convenient manner for a user to grasp ferrule carrier **200** when assembling or disassembling a connector.

An optical fiber bundle **250** extends from the rear of ferrule carrier **200**. In the case of a multifiber ferrule, optical fiber bundle **250** contains multiple fibers encased in a protective covering.

FIG. 3 shows a connector **300** incorporating ferrule carrier **200**. Connector **300** includes a housing that has an outer shell

5

310. In this example, outer shell **310** is tubular and sized to receive a single ferrule carrier **200**. Embodiments in which the outer shell receives multiple ferrule carriers are also possible.

Outer shell **310** includes features that receive latches **224**, here a slot **312**.

The housing of connector **300** also includes an inner shell **322**. Inner shell **322** fits within outer shell **310** and may slide relative to outer shell **310**. Spring **324** biases inner shell **322** forward.

When two connectors mate, mating faces **326** of the connectors press against each other. The pressure causes inner shell **322** to be retract into outer shell **310**.

Inner shell **322** includes a door assembly **330**. Door assembly **330** contains one or more retractable doors (not numbered) that normally cover mating face **326**. When inner shell **310** retracts into outer shell **310**, the doors are actuated to swing open. In this way, the mating faces of the ferrules are protected, but are exposed for mating when the connectors are pressed together.

FIG. **4** shows a connector assembly, including two connectors, **410A** and **410B**. Alignment of connectors **410A** and **410B** is achieved in a panel adapter **420**. Here, connectors **410A** and **410B** are duplex connectors, meaning that each contains two ferrule carriers, such as ferrule carrier **200** (FIG. **2**).

Adapter **420** aligns connectors **410A** and **410B** so that they will properly mate. Adapter **420** also includes latching features **422** and **424** to latch the connectors in place when mated.

FIG. **5** shows an alternative configuration of a connector assembly. FIG. **5** shows a backplane connector assembly **500**. Daughter card connector **520** is mounted to a daughtercard **512**. Backplane connector **550** is mounted to backplane **510**.

Daughter card connector **520** contains multiple connectors **522A**, **522B** and **522C**. Also, latching modules **524** engage complementary latching modules **554** that are part of backplane connector **550**. Engagement between latching modules **524** and **554** holds the connectors together when mated.

Daughter card connector **520** includes a support member **526**. Here, an elongated metal member having openings to receive individual connectors provides a base to which the components of the connector can be attached.

Backplane connector **550** also includes a support member. Here, a housing **556** provides a base to which components of the connector can be attached. Housing **556** has multiple channels formed in it. Individual connectors, such as **410A** and **410B**, can be mounted inside the channels in housing **556**. The channels also receive connectors **522A**, **522B** and **522C** of daughter card connector **520**. Housing **556** aligns the individual connectors for mating.

Connector assemblies shown in FIGS. **3**, **4** and **5** are described for use with multifiber ferrules in the above referenced patent applications. These assemblies contain substantial numbers of components in addition to a ferrule and the ferrule holder. Housings are needed to hold the ferrule carriers. Adapters are used with the connectors. And, as part of a connector assembly, latching must be provided.

FIG. **6** shows a single fiber ferrule, as is known in the art. It would be desirable to have a fiber optic connector assembly like those shown above that could be used for single fiber ferrules. A manufacturer or seller of optical fiber assemblies would achieve significant advantages if connector assemblies for single fiber ferrules could be assembled with the same pieces as used to make connector assemblies for multifiber ferrules.

6

Single fiber ferrule **600** has a mating face **610**. Cylindrical portion **612** is a precision component. A fiber end is exposed in the mating face at a location precisely positioned relative to the outer surfaces of cylindrical portion **612**. When two ferrules, such as ferrule **600** mate, they are held together in a sleeve that aligns the outer surface of cylindrical portion **612**, which also aligns the fibers.

Block **614** aids in connection of the ferrule to a connector. The fiber projects from rear surface **616**. The fiber is usually enclosed in a protective sheath.

FIG. **7** shows two single fiber ferrules **600** assembled into a ferrule carrier assembly **700**.

Ferrule carrier assembly **700** contains a support member **720**. Support member **720** preferably has the same exterior dimensions as ferrule carrier assembly **200** (FIG. **2**). Support member **720** has latches **724** positioned similarly and serving the same function as latches **726**. Also, handles **726** are positioned similarly and serve the same function as handles **226**. And, as with ferrule carrier assembly **200**, the mating faces of the ferrules are exposed at a forward end of the ferrule carrier assembly.

Optical fibers are not shown in FIG. **7**. However, the mating faces **610** of the ferrules are visible. As in FIG. **6**, the fiber is preferably positioned in the center of the mating faces. Also, boots **750A** and **750B** are shown. In a completed assembly, optical fiber would extend through the boots. The boots protect the fiber and aid in attachment of the fiber to the ferrule carrier assembly.

Support member **720** also includes attachment features such as **730**. Attachment features provide a place to attach a cap to ferrule carrier assembly **700**. As will be described in greater detail below, the ability to attach a cap provides several advantages that allows a ferrule carrier assembly to be used for many applications.

FIG. **8** shows a connector assembly **800**. Connector assembly **800** includes a single fiber ferrule carrier **810**, similar to the one shown in FIG. **7**. Connector assembly **800** also includes a connector housing **860**, similar to the housings shown for the connectors of FIGS. **3**, **4** and **5**. Ferrule carrier **810** is inserted into housing **860**. Because of the design of ferrule carrier **810**, the same housing **860** can be used for ferrule carrier **810**, carrying single fiber ferrules, or ferrule carrier **200**, carrying a multifiber ferrule. For example, single fiber ferrule carrier **810** includes latching features, such as latches **824** that operate similarly to the latching features **224** on multifiber ferrule carriers.

A further reason that single fiber ferrule carrier is operable in housing **860** is that alignment features normally found in an adapter used to mate connectors with single fiber ferrules have been incorporated into ferrule carrier **810**. Cap **830** contains alignment sleeves normally contained within a single fiber ferrule adapter.

In the preferred embodiment, cap **830** is made as a separate piece from support member **820**. Only one alignment sleeve is needed for each pair of mating ferrules. Therefore, only one cap is needed for two ferrule carriers. By constructing the cap containing the alignment sleeves as a separate component, the same support member can be used for all single fiber ferrule carriers in the connector assembly. Cap **830** can then be attached to support **820**.

FIG. **9** shows an exploded view of single fiber ferrule carrier **810**. Cover **910** engages with support **820**. With cover **910** removed, a cavity in the interior of support **820** is accessible. Ferrule assemblies are inserted into this cavity. Here, two ferrule assemblies are shown, with ferrule assembly **950A** being numbered.

7

Ferrule assembly **950A** includes a ferrule **600**. Ferrule **600** is inserted through an opening **922** in the mating face of support **820**. Block **614** does not fit through opening **922**, thereby retaining ferrule **600** within carrier **810**. Support **820** includes a channel **980** into which block **614** fits. In this way, the ferrule can slide, over at least a certain range of motion within support **820**. This range of motion is important to provide compliance as connectors mate.

Cylindrical ring **952** surrounds the fiber to the rear of clock **614**. Spring **954** surrounds the optical fiber. The forward end of spring **954** presses against ring **952**. A similar ring **956** surrounds the fiber to the rear of spring **954**.

During installation of ferrule assembly **950A** in ferrule carrier **810**, spring **954** is compressed, allowing ring **956** to move forward of abutments **926** and **928** in the cavity of support **820**. When spring **954** is released, the spring force will cause ring **956** to press against abutments **926** and **928**. Likewise, ring **952** will press against block **614**, ensuring that it is biased forwards in the connector. However, spring **954** allows sufficient compliance to take up for any mismatch in ferrule positioning when ferrules in two connectors are mated.

The rearward portion of ferrule assembly **950A** includes a crimp ring, such as crimp ring **960**. Crimp ring **960** holds a protective sheath to the cable. Boot **970** fits over the fiber and crimp ring **960**. Boot **970** protects the fiber, such as by preventing it from being bent into too tight a curve.

Rib **924** provides a channel to ensure that spring **954** stays positioned.

FIG. **9** also shows cap **830** in greater detail. In the preferred embodiment, cap **830** is made of two identical shell pieces **930A** and **930B** that snap together. When snapped together and installed on a support member, openings **934** surround an attachment feature such as feature **730** (FIG. **7**). However, the precise method of attachment is not critical. Latching, friction or interference fit might be used. Additionally, permanent forms of attachment might be used, attachment methods using glue or heat fusion might be used. Also, though making the cap as a separable piece is desirable for many applications, it could be integrally formed with support **820**.

Shell pieces **930A** and **930B** include latching structures such as posts **938** and holes **940** that hold the shell pieces together. The precise form of attachment of shell pieces **930A** and **930B** is also not critical. The pieces could be joined in a separable or permanent method. Also, it is possible that cap **830** could be made as a single piece.

Each shell piece **930A** and **930B** includes channels **936**. When the shell pieces **930A** and **930B** are connected together, alignment sleeves **932A** and **932B** are held within the channels **936**. Alignment sleeves are held adjacent the openings **922** in the **10** mating face of ferrule carrier **810**. In this way, each of the ferrules **600** will enter one of the alignment sleeves **932A** or **932B**.

In the preferred embodiment, alignment sleeves **932A** and **932B** are alignment sleeves as are generally used in adapters for single fiber ferrules. They can be made of material such as brass or ceramic. They also contain a split along their long axis to allow for a precise fit around a ferrule.

The material used to form support **820** and cap **830** is not critical. These components could, for example, be molded of plastic.

FIG. **10** shows an alternative implementation of a ferrule carrier for single fiber ferrules. Single fiber ferrule carrier **1010** includes a support **1020**. Support **1020** is adapted to receive a ferrule assembly **1050**, that includes two ferrules in one assembly.

8

As in the embodiment of FIG. **9**, each of the ferrules has a fiber running to it. Also, a forward ring **952**, a spring **954** and a rearward ring **956** are provided around each fiber.

In the embodiment of FIG. **10**, the ferrule assembly is inserted from the rear of the ferrule carrier. Rather than having a removable side, such as **910** (FIG. **9**), support **1020** has an rearward opening **1012** into an interior cavity sized to receive the ferrule assembly **1050**. To secure ferrule assembly **1050** in support **1020**, clip **1024** is used.

Clip **1024** has curved portions **1026** that conform to the shape of ferrule assembly **1050** at locations **1052**. Clip **1024** fits through window **1022** in support **1020** and has latching features that hold it in the window once inserted.

To install ferrule assembly **1050** into support **1020**, ferrule assembly **1050** is pressed forward into support **1020** until location **1052** is visible through window **1022**. Clip **1024** is then inserted through the window, engaging the ferrule assembly **1050** at location **1052**, which is rearward of ring **956**. Clip **1024** therefore precludes the ferrule assembly from being removed from support **1020**. However, the ferrules **600** may still exhibit compliant motion by compression of springs **954**.

Clip **1024** has latching features **1028** that hold it in support **1020** once installed. An alternative embodiment to facilitate removal of clip **1024** would be to make the clip with non-latching shoulders in place of latching features **1028**. To secure the clip, window **1022** would have two regions. The first region would be sized to receive the entire clip **1024**. The second region would be positioned to the rear of the first region. This region would be partially closed off with overhangs. These overhangs would be sized to project over the shoulder regions of the clip. Thus, the clip could be inserted into the first region and then slid rearward into the second region. Once in the second region, the overhanging portions would prevent the clip from being pulled out from the side. Because, in operation, spring **954** presses clip **1024** to the rear, force from spring **954** would keep clip in the second region once the ferrule carrier was assembled.

With the alternative embodiment, the clip could be removed by pressing the ferrule assembly **1050** forward in support **1020**. Pressing the ferrule assembly forward would relieve the force on the clip and allow it to slide forward into the first region, where it could be removed from the side. Various tools might be used to aid in the removal of the clip. One possibility is that the clip could be made of a magnetic material, such as magnetic stainless. A magnet placed to the side of the ferrule carrier would remove the clip once the force from springs **954** was removed.

FIG. **10** also shows that an identifying chip **1030** may be inserted into support **1020**. The use of chips that can be inserted and removed from connectors to provide easy visual identification of components is described more fully in our co-pending US patent application entitled "Fiber Optic Bulkhead Connector" filed on the same date as the present application, which is incorporated herein by reference.

FIG. **11** shows the mating configuration of portions of two single fiber ferrule carriers. In the preferred embodiment, the ferrule carriers would be inserted in connectors, such as is shown in FIG. **3**. The connectors would likely then be held within an adapter. The shell portions, such as **310** and the adapter are not shown in FIG. **11** for clarity. However, a suitable adapter is described in our co-pending US patent application entitled "Fiber Optic Bulkhead Connector" filed on the same date as the present application, which is incorporated by reference herein.

Portions of ferrule carriers **810A** and **810B**. One shell piece **930B** of cap **830** is shown attached to ferrule carrier **810B**. Support **820A** of a ferrule carrier **810A** is shown. Ferrule

9

carrier **810A** does not include a cap **830** because only one such cap is required to align a pair of ferrule carriers.

As can be seen, ferrules **600A** and **600B** are aligned within channels **936**. Alignment sleeves **932A** or **932B** are not shown. However, they would be present in a preferred embodiment and would surround the mating interfaces of the ferrules within the channels **936**.

The optical connection system described above has a modular design that simplifies the manufacture of optical interconnection systems. The carrier for single fiber ferrules can be assembled into an optical interconnection system using the same components as a multi-fiber ferrule connector. This feature allows a manufacturer or distributor of interconnection components to have a smaller number of component types that are each more widely used. There is an advantage to using many copies of one component type rather than needing to make a smaller number of more component types.

Also, this compatibility allows a system to be designed for single fiber ferrule interconnects but upgraded to ferrules with more fibers if need changes. This upgrade can be performed by changing only the ferrule carrier, leaving the rest of the connector assembly, including adapters, latching members, etc. intact.

Modularity of design is also employed in single fiber ferrule carriers. Even though only one ferrule carrier in a mating pair requires alignment features, the same basic design for each ferrule carrier can be used. A cap, which can be made as a separate module, can be added to one of the carriers to incorporate the alignment features.

Having alignment features on the ferrule carriers means that no ferrule specific alignment features are required in an adapter. This feature has the further advantage of promoting modularity of the overall connector system. Changes in the specific ferrule design do not require changes in the adapter or other portions of the interconnection system except the ferrule carrier.

Having thus described several aspects of at least one embodiment of this invention, it is to be appreciated various alterations, modifications, and improvements will readily occur to those skilled in the art. Such alterations, modifications, and improvements are intended to be part of this disclosure, and are intended to be within the spirit and scope of the invention.

For example, a ferrule carrier is described as suitable for use with cylindrical ferrules. Such a ferrule carrier has round openings in a support member that generally match the outline of the ferrule. It is not necessary either that the ferrules used be cylindrical, that the openings through which the ferrule face is exposed are round or that the openings match the outline of the ferrule. The ferrule carrier might have a U-shaped section that provides support but still provides an opening through which the face of the ferrule is accessible while still providing support. Alternatively, ferrule carrier might employ a rigid sheet or beam with the ferrule mounted to it. Accordingly, many different shapes for support members may be used.

Accordingly, the foregoing description and drawings are by way of example only.

What is claimed is:

1. A ferrule carrier, comprising:

- a) a support having a mating face with at least one opening therein, at least one first attachment feature disposed at the mating face, and at least one second attachment feature disposed behind the mating face that is adapted to make a separable connection to an optical connector housing;
- b) at least one cylindrical ferrule having a forward face and a rearward face, the forward face of the cylindrical ferrule being aligned with the at least one opening;

10

- c) at least one alignment sleeve aligned with the forward face of the at least one cylindrical ferrule; and
- d) a cap attached to the support at the mating face by the at least one first attachment feature, the cap having at least one cylindrical channel adapted to enclose the at least one alignment sleeve entirely therein and to couple the at least one alignment sleeve with the support.

2. The ferrule carrier of claim **1**, wherein the support has a side surface with at least one window disposed therein and the at least one cylindrical ferrule is slidably mounted in the support, the ferrule carrier additionally comprising:

- e) at least one optical fiber extending from the at least one cylindrical ferrule at its rearward face;
- f) at least one spring surrounding the at least one optical fiber;
- g) at least one clip member having a portion adjacent to the at least one fiber, the at least one clip member being mounted within the at least one window of the side surface.

3. The ferrule carrier of claim **2**, additionally comprising:

- h) at least one block attached to the at least one ferrule; and
- i) at least one ring encircling the at least one fiber.

4. The ferrule carrier of claim **2**, wherein the at least one clip is removable.

5. The ferrule carrier of claim **1**, the ferrule carrier having a visually identifying member inserted therein.

6. An optical fiber connector using the ferrule carrier of claim **1**, wherein the ferrule carrier is removably received in the optical connector housing.

7. The optical fiber connector of claim **6**, wherein the optical connector housing comprises a door assembly, the door assembly having at least one movable door that selectively covers the forward face of the ferrule.

8. An optical fiber connector assembly using the optical fiber connector of claim **6**, additionally comprising an adapter, wherein the optical connector housing is removably attached to the adapter, and wherein the adapter does not contain ferrule alignment features.

9. A ferrule carrier, comprising:

- a) a support having a mating face with at least one opening therein, a side surface with at least one window disposed therein, and at least one attachment feature adapted to make a separable connection to an optical connector housing;
- b) at least one cylindrical ferrule slidably mounted in the support and having a forward face and a rearward face, the forward face of the cylindrical ferrule being aligned with the at least one opening;
- c) at least one alignment sleeve aligned with the forward face of the cylindrical ferrule;
- d) a cap attached at the mating face of the support having at least one cylindrical channel adapted to enclose the at least one alignment sleeve entirely therein and to couple the at least one alignment sleeve with the support;
- e) at least one optical fiber extending from the at least one cylindrical ferrule at its rearward face;
- f) at least one spring surrounding the at least one optical fiber; and
- g) at least one clip member having a portion adjacent to the fiber, the at least one clip member being mounted within the at least one window of the side surface.

10. The ferrule carrier of claim **9**, additionally comprising:

- h) at least one block attached to the at least one ferrule; and
- i) at least one ring encircling the at least one fiber, wherein the at least one spring is positioned between the at least one block and at least one ring.

11

11. The ferrule carrier of claim **9**, wherein the at least one clip is removable.

12. The ferrule carrier of claim **9**, the ferrule carrier having a visually identifying member inserted therein.

13. An optical fiber connector using the ferrule carrier of claim **9**, wherein the ferrule carrier is removably received in the optical connector housing.

14. The optical fiber connector of claim **13**, wherein the optical connector housing comprises a door assembly, the

12

door assembly having at least one movable door that selectively covers the forward face of the ferrule.

15. An optical fiber connector assembly using the optical fiber connector of claim **13**, additionally comprising an adapter, wherein the optical connector housing is removably attached to the adapter, and wherein the adapter does not contain ferrule alignment features.

* * * * *

UNITED STATES PATENT AND TRADEMARK OFFICE
CERTIFICATE OF CORRECTION

PATENT NO. : 7,651,278 B2
APPLICATION NO. : 11/907064
DATED : January 26, 2010
INVENTOR(S) : Sepehr Kiani et al.

Page 1 of 1

It is certified that error appears in the above-identified patent and that said Letters Patent is hereby corrected as shown below:

At column 7, line 58, replace the word "The" with --They--

At column 8, lines 53-54, replace the word "Bull-head" with --Bulk-head--

Signed and Sealed this

Seventeenth Day of August, 2010

A handwritten signature in black ink that reads "David J. Kappos". The signature is written in a cursive style with a large initial 'D' and 'K'.

David J. Kappos
Director of the United States Patent and Trademark Office