

US007647771B2

(12) **United States Patent**
Thomsen, III et al.

(10) **Patent No.:** **US 7,647,771 B2**
(45) **Date of Patent:** **Jan. 19, 2010**

(54) **THERMALLY DRIVEN PISTON ASSEMBLY AND POSITION CONTROL THEREFOR**

(75) Inventors: **Donald L. Thomsen, III**, Yorktown, VA (US); **Robert G. Bryant**, Lightfoot, VA (US)

(73) Assignee: **The United States of America as represented by the Administrator of the National Aeronautics and Space Administration**, Washington, DC (US)

(*) Notice: Subject to any disclaimer, the term of this patent is extended or adjusted under 35 U.S.C. 154(b) by 249 days.

(21) Appl. No.: **11/374,480**

(22) Filed: **Mar. 8, 2006**

(65) **Prior Publication Data**
US 2006/0236690 A1 Oct. 26, 2006

Related U.S. Application Data
(60) Provisional application No. 60/662,343, filed on Mar. 9, 2005.

(51) **Int. Cl.**
F01B 29/10 (2006.01)

(52) **U.S. Cl.** **60/527; 60/528**

(58) **Field of Classification Search** **605/527-529**
See application file for complete search history.

(56) **References Cited**

U.S. PATENT DOCUMENTS

3,438,256 A * 4/1969 Schwartz 60/527
4,843,293 A 6/1989 Futami

5,025,627 A * 6/1991 Schneider 60/527
5,491,372 A 2/1996 Erhart
5,557,154 A 9/1996 Erhart
6,476,537 B1 11/2002 Pease et al.
6,543,224 B1 * 4/2003 Barooah 60/527
6,707,231 B2 3/2004 Pease et al.
6,806,600 B2 10/2004 Willacy et al.

FOREIGN PATENT DOCUMENTS

JP 2003205496 A * 7/2003

OTHER PUBLICATIONS

S. Courty, J. Mine, A.R. Tajbakhsh, and E.M. Terentjev, "Nematic Elastomers With Aligned Carbon Nanotubes: New Electromechanical Actuators," Europhysics Letters, EDP Sciences, p. 654-660.

* cited by examiner

Primary Examiner—Hoang M Nguyen

(74) *Attorney, Agent, or Firm*—Robin W. Edwards

(57) **ABSTRACT**

A thermally driven piston assembly's housing has (i) a first material slidingly fitted therein, and (ii) at least one plug of a second material slidingly fitted therein and abutting the first material. The first material is one (e.g., a liquid crystal elastomer) that undergoes a stiffness change and/or a dimensional change when subjected to a temperature change in the temperature range of interest. When subjected to the temperature change while in the housing, the first material is restricted to changing dimensionally along a single dimension. The second material retains its shape and size throughout the temperature range of interest. As a result, the plug moves in the housing in correspondence with the dimensional change of the first material or the plug's movement is damped by the stiffness change of the first material.

39 Claims, 5 Drawing Sheets

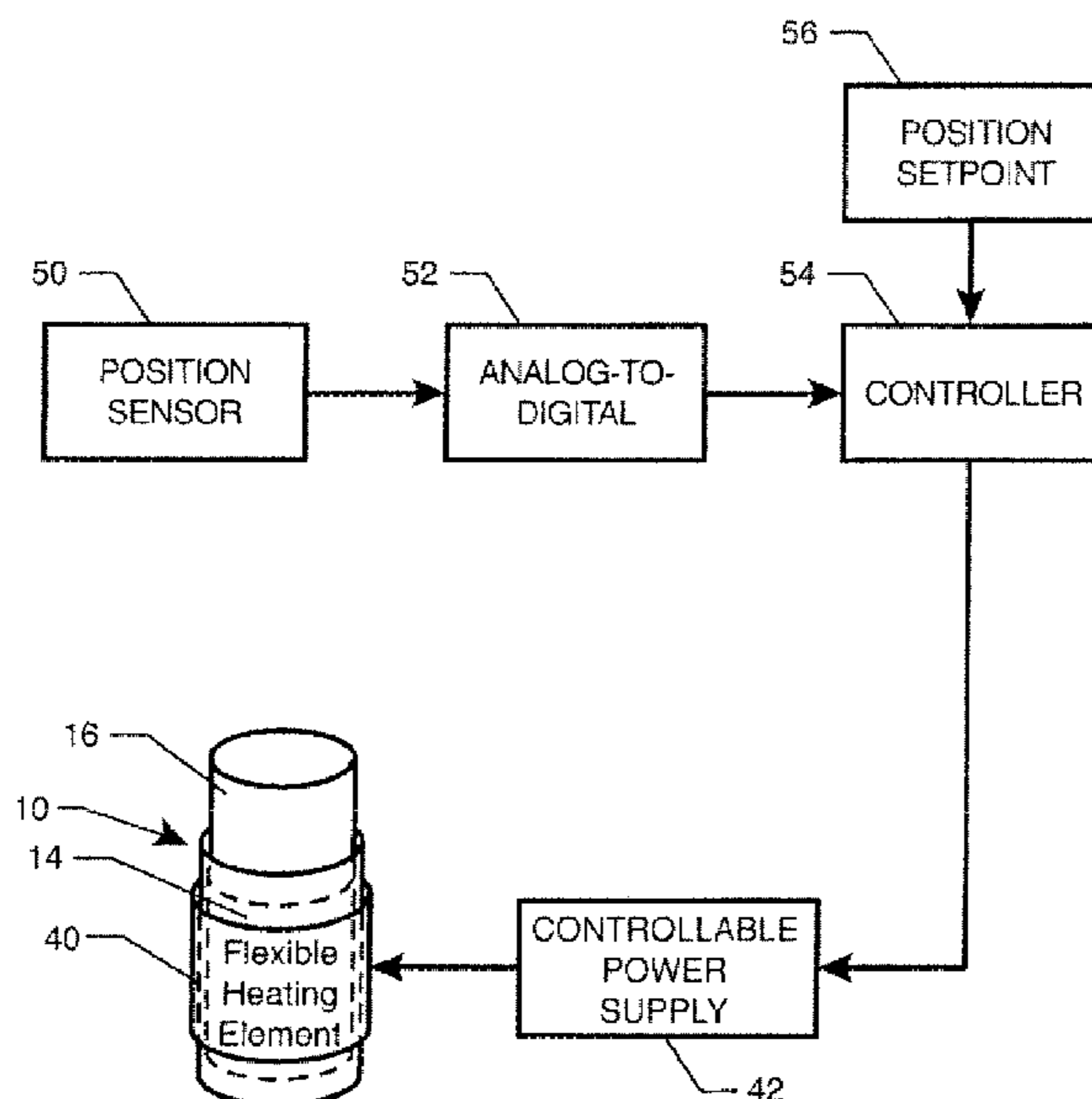

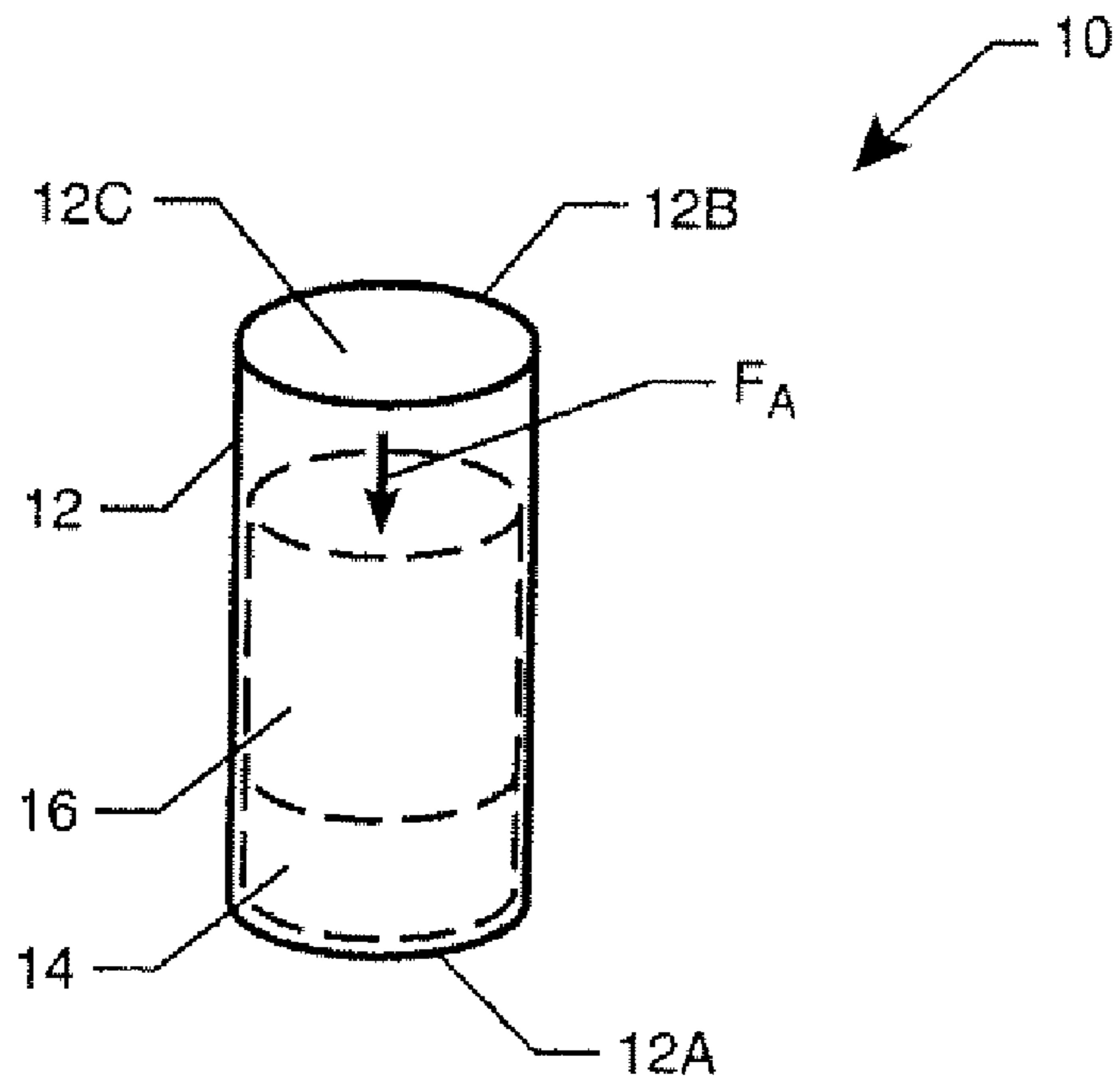

Fig. 1

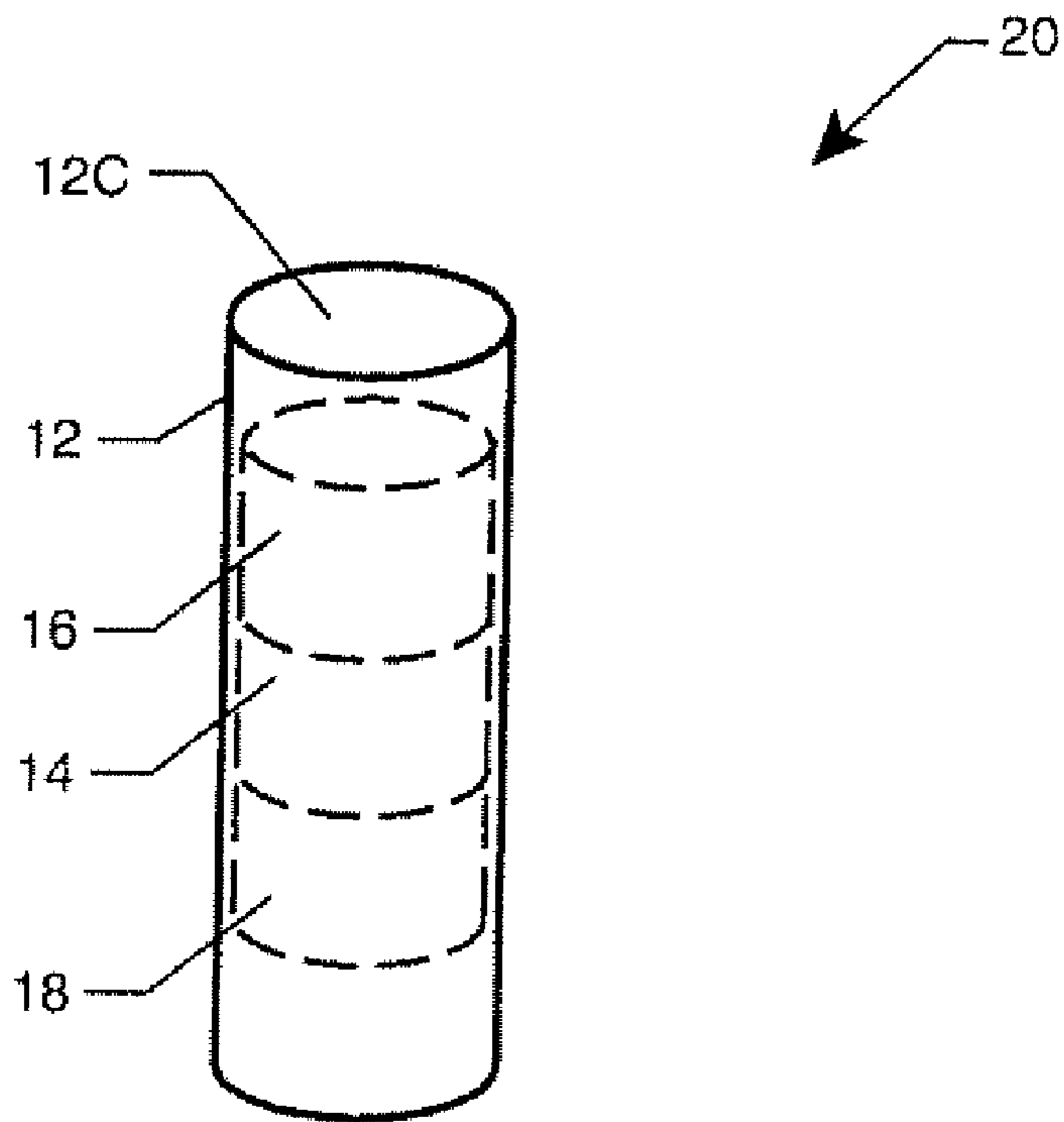

Fig. 2

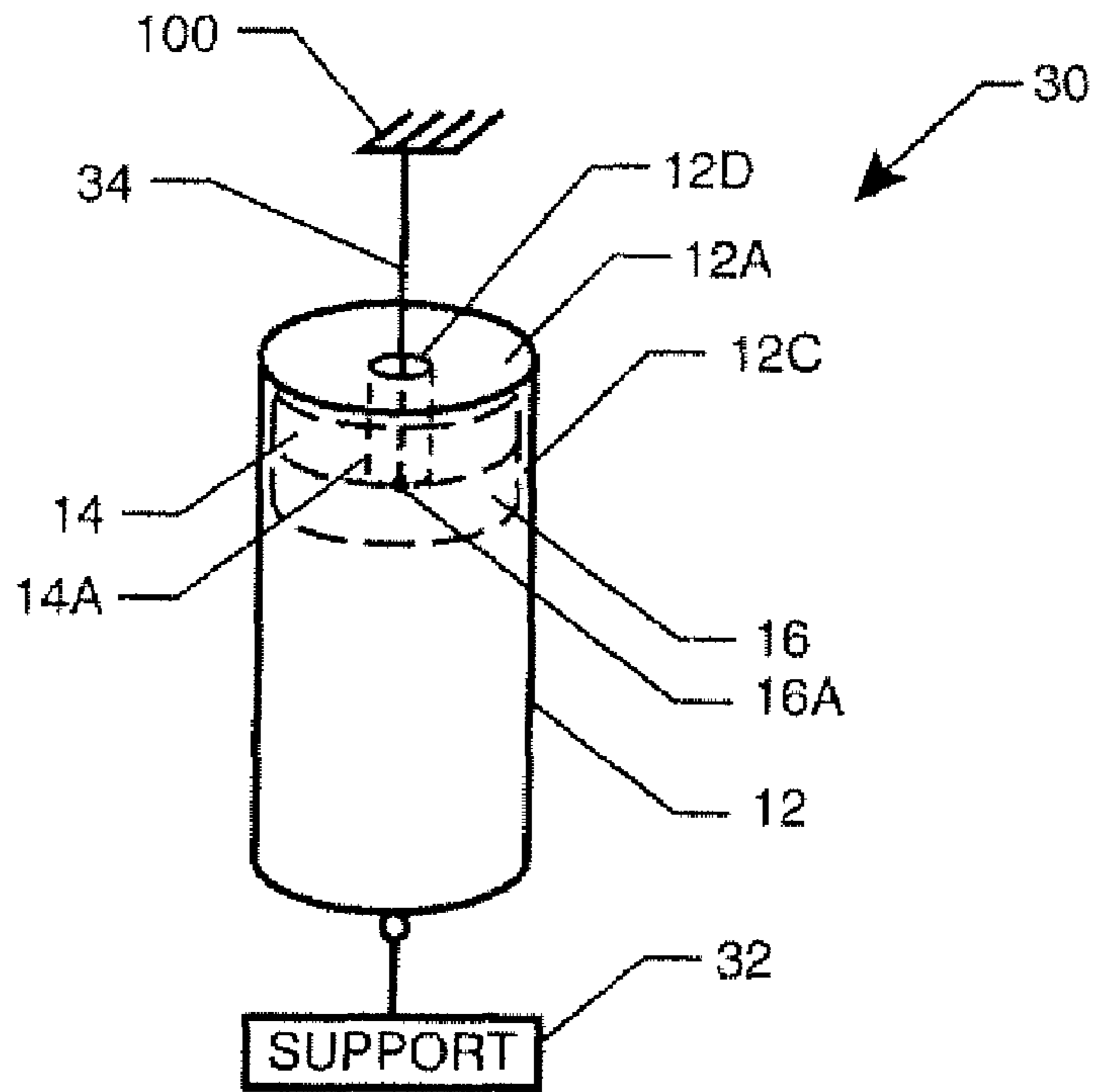

Fig. 3

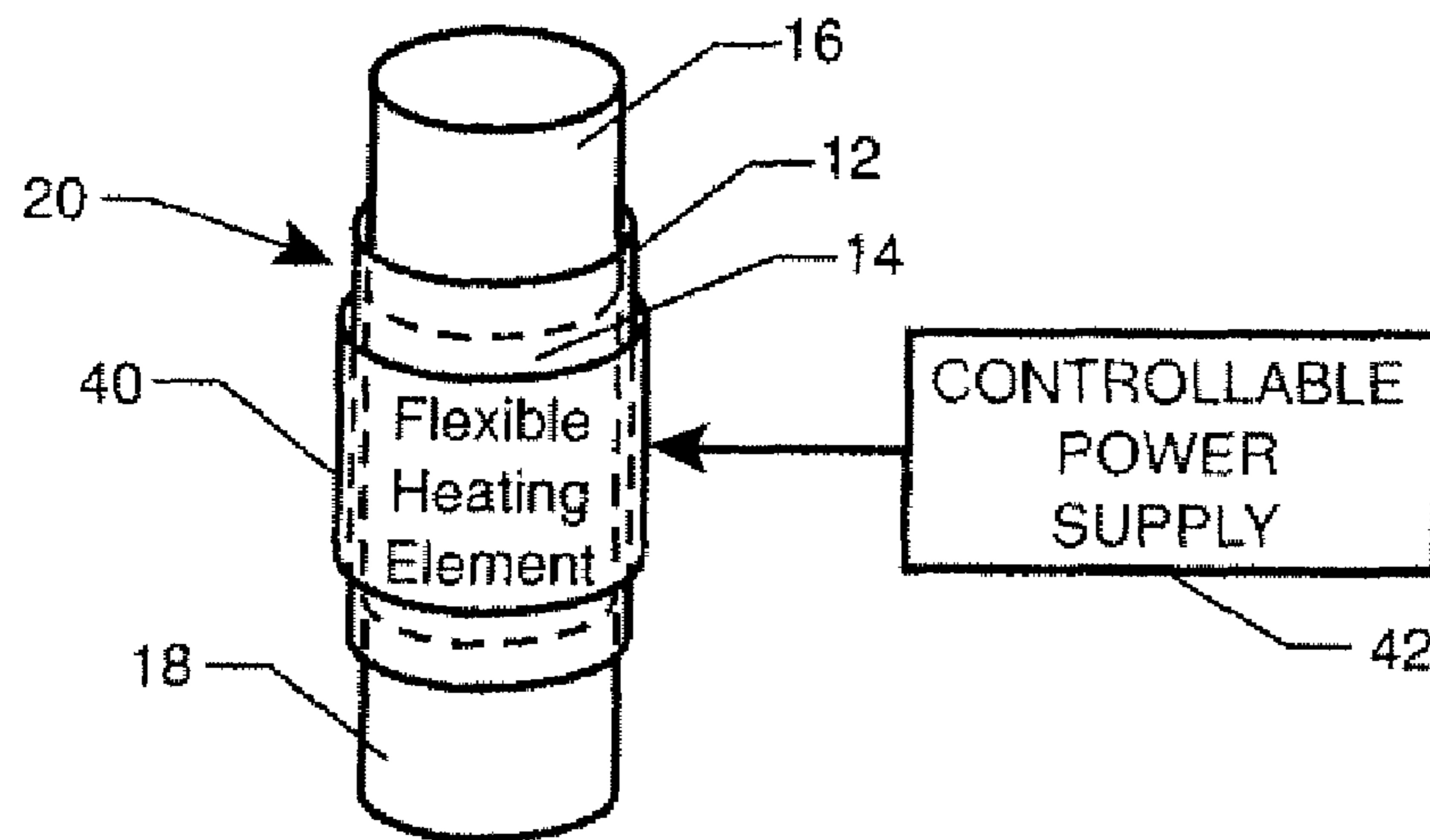

Fig. 4

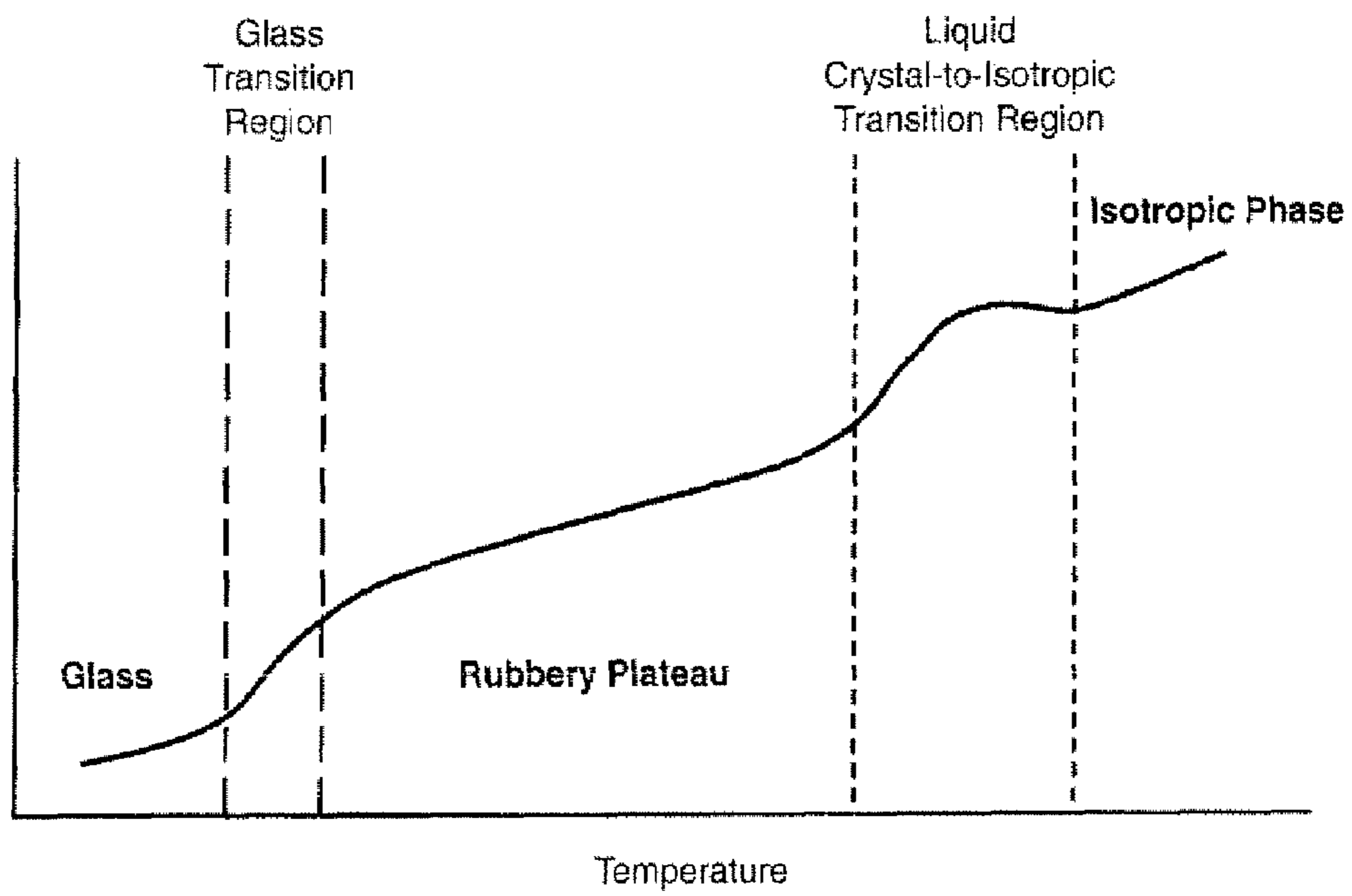

Fig. 5

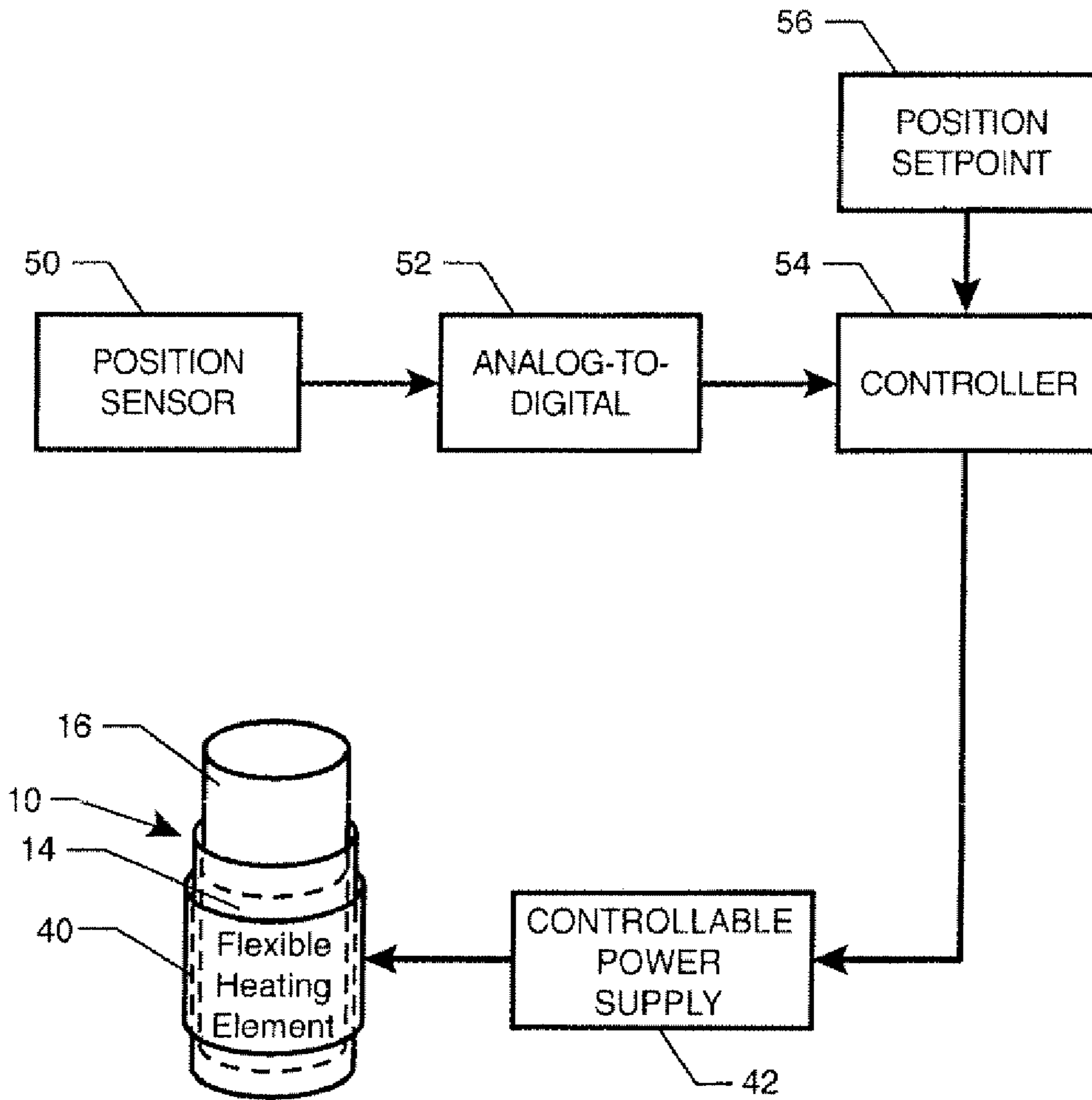

Fig. 6

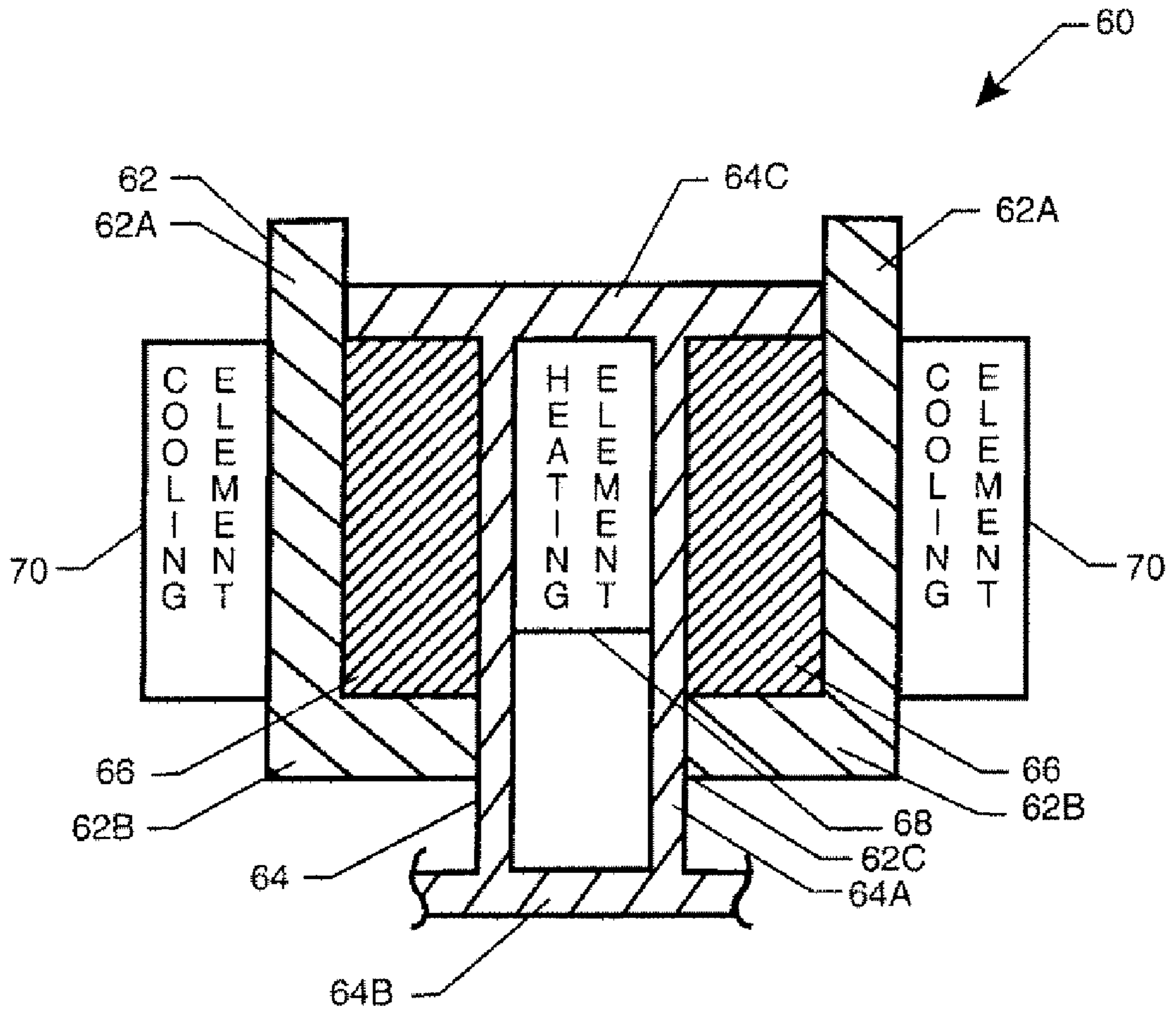

Fig. 7

1

THERMALLY DRIVEN PISTON ASSEMBLY AND POSITION CONTROL THEREFOR

Pursuant to 35 U.S.C. § 119, the benefit of priority from provisional application 60/662,343, with a filing date of Mar. 9, 2005, is claimed for this non-provisional application.

ORIGIN OF THE INVENTION

The invention described herein may be manufactured and used by or for the Government of the United States of America for governmental purposes without the payment of any royalties thereon or therefor.

BACKGROUND OF THE INVENTION

1. Field of the Invention

This invention relates to actuator or damping devices utilizing a piston. More specifically, the invention is a thermally driven piston assembly and position control system therefor with the piston being able to function as an actuator or a damping device.

2. Description of the Related Art

In the past, linear actuators required a transmission system to convert a motor's rotational energy into linear displacement. However, such linear actuators systems are not practical in many space-restricted applications. More recently, linear actuators use hydraulic or pneumatic driven pistons or have been made from stacks of piezoelectric materials that can generate a strong linear force when space is at a premium. However, hydraulically/pneumatically driven pistons require a pump to effect volumetric or pressure changes that move a piston. Piezoelectric-based linear actuators have low strain characteristics, thereby limiting their linear travel.

Currently, a variety of muscle-like polymer materials are being evaluated for use in actuator or damping devices owing to their ability to undergo large changes in strain and stiffness when activated. However, there is a need to provide simple and efficient actuator "packages" for these materials that capitalize on their large strain characteristics to achieve a linear actuator or damping response. Further, since several of these polymer materials have a tendency to exhibit creep, the actuator package that includes such polymer materials must be able to compensate for a material's creep characteristics.

SUMMARY OF THE INVENTION

Accordingly, it is an object of the present invention to provide the means to generate a linear response using a muscle-like polymer material.

Another object of the present invention is to provide the means to generate and control a linear response of a muscle-like polymer in order to compensate for the material's creep characteristics.

Still another object of the present invention is to generate a tunable damping response using a muscle-like polymer material.

Other objects and advantages of the present invention will become more obvious hereinafter in the specification and drawings.

In accordance with the present invention, a thermally driven piston assembly has a housing that remains rigid throughout a temperature range of interest. A first material is slidably fitted in a hollow portion of the housing such that the first material is limited to movement along a single dimension of the hollow portion. The first material is one (e.g., a liquid crystal elastomer) that undergoes a stiffness change and/or a

2

dimensional change when subjected to a temperature change in the temperature range of interest. When subjected to the temperature change while in the housing, the first material is restricted to changing dimensionally along the single dimension. At least one plug of a second material is slidably fitted in the housing's hollow portion adjacent the first material. The second material retains its shape and size throughout the temperature range of interest. As a result, the plug moves in the housing's hollow portion along the afore-said single dimension in correspondence with the dimensional change of the first material or the plug's movement is damped by the stiffness change in the first material. A position control system can be provided if the first material has inherent creep characteristics.

BRIEF DESCRIPTION OF THE DRAWINGS

FIG. 1 is a perspective view of a thermally driven piston assembly providing linear motion or damping forces in accordance with an embodiment of the present invention;

FIG. 2 is a perspective view of a thermally driven piston assembly providing linear motion simultaneously in two opposing directions in accordance with another embodiment of the present invention;

FIG. 3 is a perspective view of a thermally driven piston assembly that can generate a tension force in accordance with another embodiment of the present invention;

FIG. 4 is a side view of a thermally driven piston assembly of FIG. 2 further including a controllable heater for actuating the assembly's thermally-active shape changing material;

FIG. 5 is a graph of temperature versus enthalpy change for a liquid crystal elastomer;

FIG. 6 is a schematic view of the thermally driven piston assembly of FIG. 1 further including a position control system coupled thereto to detect and compensate for creep inherent in the assembly's thermally-active shape changing material; and

FIG. 7 is a part cross-sectional, part schematic view of another embodiment of a piston assembly in accordance with the present invention.

DETAILED DESCRIPTION OF THE INVENTION

Referring now to the drawings, and more particularly to FIG. 1, an embodiment of a thermally driven piston assembly in accordance with the present invention is shown and is referenced generally by numeral 10. Piston assembly 10 can be operated to perform an actuation, damping, or sensing function without departing from the scope of the present invention. Briefly, in an actuation or damping operation, heat is applied in a controlled fashion to generate piston movement (for actuation) or force (for damping). In a sensing operation, an environment's changing temperature causes piston movement/force with such movement/force being used as an indicator of the changing temperature. However, the operating principles of piston assembly 10 are the same for each of these functions.

Piston assembly 10 includes housing 12, a thermally-active shape changing material 14 that is shaped/sized to slidably fit in housing 12, and a plug or "piston" 16 slidably fit in housing 12 and made from a material that retains its shape when exposed to temperatures that are sufficient to activate the shape changing features of material 14.

Housing 12 is closed or otherwise configured at an end 12A thereof that abuts shape changing material 14 to retain material 14 at end 12A. Housing 12 can be closed or opened at opposing end 12B. Housing 12 defines a hollow portion 12C

thereof that slidably receives each of material **14** and piston **16**. Hollow portion **12C** is typically cylindrical but can define other two-dimensional geometries (e.g., triangular, polygon, etc.) without departing from the scope of the present invention. Housing **12** can be made of any material that will retain a rigid shape throughout a temperature range of interest, i.e., a temperature range that will activate the shape changing features of material **14**. Additionally, housing **12** can be made from a thermally conductive material to transfer either an applied heat energy or environmental heat energy to material **14**.

Shape changing material **14** is any material that changes dimensionally and/or in stiffness with temperature changes while retaining elasticity and viscosity. Material **14** can be any thermally-active material that possesses a restoring force or spring constant owing to the material's chemical or physical cross-linking properties. By radially restraining material **14** as is the case for a cylindrical hollow portion **12C** of housing **12** (or by restraining material **14** two-dimensionally in length/width as is the case for a polygonally-shaped hollow portion **12C**), any dimensional change in material **14** is restricted to the axial dimension of hollow portion **12C**. That is, the dimensional change in material **14** in the presence of a temperature change amounts to a linear movement of material **14**. Since material **14** is restrained from such linear movement at end **12A** of housing **12**, the linear movement of material **14** is restricted towards or away from end **12A**.

The present invention can also operate as a damping device when material **14** experiences changes in stiffness with changes in temperature. Referring again to FIG. 1, assume material **14** is further limited in or restricted from axial movement by means of (for example) an axial force **FA** applied to piston **16**. With material **14** being capable of experiencing changes in stiffness with changes in temperature, then piston assembly **10** can be controlled to act as an axial force damping device. In this instance, it is possible that material **14** will experience little or no dimensional changes.

Suitable choices for material **14** include a variety of viscoelastic materials satisfying the above-noted criteria. For example, polymers such as polyurethanes and liquid crystal elastomers (LCE) are good choices as these materials exhibit good viscoelastic properties in their glass transition regions and in their phase transition regions. In particular, LCEs have demonstrated muscle-like mechanical properties with large shape changes occurring through the nematic liquid crystal-line phase transition. Accordingly, the various embodiments described herein will reference the use of an LCE as the thermally-active shape changing material. By way of example, one suitable LCE is made from (4'-Acryloyloxybutyl) 2,5-di(4'-butyloxybenzoyloxy)benzoate and 1,6-hexanediol diacrylate in accordance with known methodologies such as those described by D. L. Thomsen, III, et al. in "Liquid Crystal Elastomers with Mechanical Properties of a Muscle," *Macromolecules* 2001, 34, pp. 5868-5875.

It is to be understood that the present invention is not limited to LCEs as a variety of elastomers, foams, crosslinked polymers, and composite matrix materials could also be used. Some representative elastomers include butadiene rubber, butyl rubber, chlorinated polyethylene, crosslinked polyethylene, chlorosulphonated polyethylene, epichlorohydrin-ethylene oxide, ethylene propylene diene terpolymer, ethylene-propylene rubber, EVA, natural rubber, nitrile rubber, polyacrylate, polymethylmethacrylate, polychloroprene, polyisoprene, polypropylene oxide, polyurethane, silicone, styrene butadiene rubber, and thermoplastic elastomers. Some representative foams include polymer foams that can be closed cell, microcellular, and open cell. Some represen-

tative crosslinked polymers include polystyrene, polyvinyl chloride, polyamino acids, proteins, polyethylene, polycarbonate, polyester, nylon, phenolic, polymethacrylimide, and polyethersulphone. Some representative composite matrix materials include polyimides, liquid crystal polymers such as liquid crystal polyesters and liquid crystal polyaramides, epoxies, polyamides, polyaramides, polyethers such as PEEK and PET, and polyarylethers such as bisphenol and cyanate ester.

Piston **16** can be any rigid material that retains its shape in the temperature range in which piston assembly **10** will operate to include the range of temperatures that can activate dimensional and/or stiffness changes in material **14**. To take advantage of the viscoelastic properties of material **14** that provide for opposing-direction dimensional changes in material **14**, piston **16** can be coupled (e.g., attached, adhered, bonded, etc.) to material **14** where piston **16** abuts thereagainst. In this way, when material **14** experiences a temperature change such that it changes dimensionally (i.e., grows or shrinks in the axial direction of housing **12**), piston **16** will move in correspondence with material **14**.

The present invention is not limited to the embodiment described above. By way of illustrative example, two other possible embodiments of the present invention will now be described with the aid of FIGS. 2 and 3. In FIG. 2, a thermally driven piston assembly **20** includes a rigid housing **12** having hollow portion **12C**, shape changing material **14** slidably fitted in hollow portion **12C**, and two pistons **16** and **18** slidably fitted in hollow portion **12C** and disposed on either side of material **14**. As in the previous embodiment, pistons **16** and **18** can be coupled to shape changing material **14**. In this way, when material **14** experiences a temperature change such that it changes dimensionally (i.e., along the axial dimension of hollow portion **12C**), the linear movement of material **14** and resultant force is imparted to pistons **16** and **18** simultaneously. As a result, pistons **16** and **18** are moved in opposing directions away from or towards one another. Piston assembly **20** could also function as a damping device in a fashion similar to that described for piston assembly **10**.

FIG. 3 illustrates a thermally driven piston assembly **30** that includes the following:

- (i) rigid housing **12** having hollow portion **12C** and having a port **12D** formed in closed end **12A**,
- (ii) shape changing material **14** slidably fitted in hollow portion **12C** and further having a hole **14A** formed there-through and aligned with port **12D** when material **14** is positioned in housing **12** adjacent closed end **12A**,
- (iii) piston **16** slidably fitted in hollow portion **12C** such that material **14** is positioned between closed end **12A** and piston **16**,
- (iv) a support **32** coupled to one end of housing **12** to prevent movement of housing **12** in its axial dimension, and
- (v) a tension member **34** rigidly coupled on one end thereof to piston **16** at **16A** and on the other end thereof to a support **100**.

In operation of piston assembly **30**, temperature changes causing an axial dimensional expansion in material **14** causes a tension force to be applied along tension member **34**. If material **14** is coupled to closed end **12A** and piston **16**, axial shrinkage of material **14** will relax the tension in tension member **34**.

In each embodiment of the present invention, thermal activation of material **14** can occur actively or passively (e.g., via environmental temperature changes). By way of example, one way of providing for active thermal activation of material **14**, is illustrated in FIG. 4. More specifically, piston assembly **20** is shown with a flexible heating element **40** wrapped about

5

housing 12 which, for this example, would be made from a thermally conductive material. Such heating elements are well known in the art and can include, for example, nichrome wire heaters, fabric heaters, heating mantles, and MINCO® brand flexible heaters. A controllable power supply 42 5 coupled to heating element 40 controls the temperature changes that will ultimately be experienced by material 14.

As mentioned above, a good choice for material 14 is a liquid crystal elastomer (LCE). A graph of temperature versus enthalpy change for a typical LCE is shown in FIG. 5. Of note 10 are the large enthalpy changes experienced in both the glass transition region and the liquid crystal-to-isotropic transition region of an LCE. That is, when the temperature of the LCE is in one of these regions, the LCE undergoes its greatest dimensional changes. In addition to providing large shape 15 changes, LCEs provide good damping properties as a result of the liquid crystal-backbone coupling.

While the shape changing characteristics of LCEs make them attractive candidates for use in the present invention, LCEs also have inherent creep tendencies at isothermal conditions. Thus, there may be applications of the present invention where fixing the temperature of the LCE does not provide the necessary position control of the piston assembly being driven by an LCE-based material 14. In these applications, it may be helpful to couple a position control system to the 20 present invention's piston assembly. For example, one such position control system is coupled to piston assembly 10 as illustrated in FIG. 6. More specifically, a position sensor 50 (e.g., a laser range finder, optical encoder, Hall effect sensor, LVDT, piezoceramic, air bearing, pneumatic, mechanical calipers, potentiometer, etc.) is positioned to sense/detect axial movement of piston 16. The output of sensor 50 is supplied to a controller 54. If necessary, the output of sensor 25 50 can be converted to digital at an analog-to-digital converter 52. A position setpoint 56 provided to controller 54 is compared to the sensed position of piston 16. The difference between the sensed position and position setpoint 56 is used to generate a feedback control signal supplied to controllable power supply 42 which is coupled to heater 40 as explained above. Position control of a piston assembly of the present invention can be used for both actuation and damping func- 40 tions.

The present invention is not limited to the piston assembly constructions described above. The "housing" used to form a piston assembly of the present invention could be constructed 45 in a variety of ways to include a variety of geometries where the geometry would then define the shape of the shape changing material. Further, the housing could be constructed to support actively-controlled heating and cooling elements.

An example of an alternative construction is illustrated in 50 FIG. 7 where the "housing" of a piston assembly 60 is formed by an annular region between housing portions 62 and 64. Housing portion 62 has an annular (cylindrical) side wall 62A and an integral annular end wall 62B having a hole 62C formed therethrough. Housing portion 64 has an annular (cylindrical) side wall 64A, a first end wall 64B, and a second opposing end wall 64C. Annular side wall 64A defines an outside diameter that slidingly fits through hole 62C. First end wall 64B is sized larger than hole 62C and is positioned on the exterior of housing portion 62. Second end wall 64C is sized 60 to slidingly fit in annular side wall 62A.

Filling the annular region between annular side wall 64A and annular side wall 62A is a donut or sleeve-shaped shape changing material 66, i.e., a material possessing the characteristics of shape changing material 14. A heating element 68 65 can be positioned within annular side wall 64A and a cooling element 70 can be provided about (e.g., wrapped about) the

6

outside of annular side wall 62A. Note that heating element 68 and cooling element 70 can switch positions without departing from the scope of the present invention. In operation, the heating and cooling elements are operated/con- 5 trolled to control the stiffness and/or dimensional changes of material 66 to provide damping for axial forces applied to housing portion 64 or linear actuation of housing portion 64.

The advantages of the present invention are numerous. The thermally-driven piston assembly can be used as a linear actuator, positioner, damping device, or thermal sensor. The assembly is easy to manufacture and is inexpensive. When made with an LCE shape changing material, the piston assembly will exhibit both muscle-like mechanical properties and damping properties. The creep tendencies of the shape 15 changing material can be controlled with a position control feedback system.

Although the invention has been described relative to a specific embodiment thereof, there are numerous variations and modifications that will be readily apparent to those skilled in the art in light of the above teachings. It is therefore to be understood that, within the scope of the appended claims, the invention may be practiced other than as specifically described.

What is claimed as new and desired to be secured by By Letters Patent of the United States is:

The invention claimed is:

1. A thermally driven piston assembly, comprising:

a housing having a hollow portion that remains rigid throughout a temperature range of interest;

30 a viscoelastic material slidingly fitted in said hollow portion such that said viscoelastic material is limited to movement along a single dimension of said hollow portion, said viscoelastic material undergoing at least one of a stiffness change and a dimensional change along said single dimension when subjected to a temperature change in said temperature range of interest, said viscoelastic material possessing and retaining viscoelastic properties throughout said temperature range of interest; at least one a plug of a second material slidingly fitted in said hollow portion adjacent said viscoelastic material, said second material being rigid and retaining its shape and size throughout said temperature range of interest; first means for measuring an amount of movement of said plug along said single dimension when said viscoelastic material is experiencing isothermal conditions, wherein said amount of movement is measured relative to a set- point; and

second means coupled to said first means for controlling said temperature change to negate said amount of movement wherein said plug returns along said single dimension to said setpoint.

2. A thermally driven piston assembly as in claim 1 wherein said hollow portion is thermally conductive.

3. A thermally driven piston assembly as in claim 1 wherein said viscoelastic material is selected from the group consisting of foam, polymer, composite matrix and elastomer.

4. A thermally driven piston assembly as in claim 3 wherein said polymer is selected from the group consisting of liquid crystal elastomer (LCE), polyurethane and crosslinked polymer.

5. A thermally driven piston assembly as in claim 4 wherein said temperature range of interest is within one of a glass transition region of said LCE and a liquid crystal-to-isotropic transition region of said LCE.

65 6. A thermally driven piston assembly as in claim 1 wherein said plug of said second material is coupled to said viscoelastic material.

7. A thermally driven piston assembly as in claim 1, further comprising a second plugs with said viscoelastic material being disposed between said first and second plugs.

8. A thermally driven piston assembly as in claim 7 wherein said first and second plugs are coupled to said viscoelastic material.

9. A thermally driven piston assembly as in claim 1 further comprising:

retention means coupled to said hollow portion for retaining said viscoelastic material and said plug within said hollow portion;

restraining means coupled to said housing for restraining movement of said housing along said single dimension; and

tensioning means coupled to said plug and passing through said viscoelastic material and said retention means along said single dimension.

10. A thermally driven piston assembly, comprising:

a housing having a hollow portion that remains rigid throughout a temperature range of interest;

a first material slidingly fitted in said hollow portion such that said first material is limited to movement along a single dimension of said hollow portion, said first material undergoing at least one of a stiffness change and a dimensional change along said single dimension when subjected to a temperature change in said temperature range of interest;

at least one plug of a second material slidingly fitted in said hollow portion adjacent said first material, said second material retaining its shape and size throughout said temperature range of interest;

position sensing means for measuring an amount of movement of said at least one plug along said single dimension when said first material is experiencing isothermal conditions, wherein said amount of movement is measured relative to a setpoint;

heating means for effecting said temperature change; and control means coupled to said sensing means and said heating means for controlling said heating means based on said amount of movement wherein said at least one plug is moved along said single dimension to be repositioned at said setpoint.

11. A thermally driven piston assembly as in claim 10 wherein said hollow portion is thermally conductive.

12. A thermally driven piston assembly as in claim 11 wherein said heating means is thermally coupled to said hollow portion.

13. A thermally driven piston assembly as in claim 10 wherein said first material is a viscoelastic material.

14. A thermally driven piston assembly as in claim 10 wherein said first material is an elastomeric material.

15. A thermally driven piston assembly as in claim 10 wherein said first material is selected from the group consisting of foam, polymer and composite matrix.

16. A thermally driven piston assembly as in claim 10 wherein said first material is a liquid crystal elastomer (LCE).

17. A thermally driven piston assembly as in claim 16 wherein said temperature range of interest is within one of a glass transition region of said LCE and a liquid crystal-to-isotropic transition region of said LCE.

18. A thermally driven piston assembly as in claim 10 wherein said at least one plug of said second material is coupled to said first material.

19. A thermally driven piston assembly as in claim 10 wherein said at least one plug comprises first and second plugs with said first material being disposed therebetween.

20. A thermally driven piston assembly as in claim 19 wherein said first and second plugs are coupled to said first material.

21. A thermally driven piston assembly as in claim 10 wherein said at least one plug comprises a single plug, said thermally driven piston assembly further comprising:

retention means coupled to said hollow portion for retaining said first material and said single plug within said hollow portion;

restraining means coupled to said housing for restraining movement of said housing along said single dimension; and

tensioning means coupled to said single plug and passing through said first material and said retention means along said single dimension.

22. A thermally driven piston assembly as in claim 3 wherein said foam is a polymer foam.

23. A thermally driven piston assembly as in claim 22 wherein said polymer foam is selected from the group consisting of closed cell, microcellular, and open cell.

24. A thermally driven piston assembly as in claim 4 wherein said crosslinked polymer is selected from the group consisting of polystyrene, polyvinyl chloride, polyamino acid, protein, polyethylene, polycarbonate, polyester, nylon, phenolic, polymethacrylimide, and polyethersulphone.

25. A thermally driven piston assembly as in claim 3 wherein said elastomer is selected from the group consisting of butadiene rubber, butyl rubber, chlorinated polyethylene, crosslinked polyethylene, chlorosulphonated polyethylene, epichlorohydrin-ethylene oxide, ethylene propylene diene terpolymer, ethylene-propylene rubber, EVA, natural rubber, nitrile rubber, polyacrylate, polymethylmethacrylate, polychloroprene, polyisoprene, polypropylene oxide, polyurethane, silicone, styrene butadiene rubber, and thermoplastic elastomer.

26. A thermally driven piston assembly as in claim 3 wherein said composite matrix is selected from the group consisting of polyimide, liquid crystal polymer, epoxy, polyamide, polyaramide, polyether, and polyarylether.

27. A thermally driven piston assembly as in claim 3 wherein said temperature range of interest is within one of a glass transition region of said polymer and a phase transition region of said polymer.

28. A thermally driven piston assembly as in claim 26 wherein said liquid crystal polymer is selected from the group consisting of liquid crystal polyester and liquid crystal polyaramide.

29. A thermally driven piston assembly as in claim 26 wherein said polyether is selected from the group consisting of PEEK and PET.

30. A thermally driven piston assembly as in claim 26 wherein said polyarylether is selected from the group consisting of such as bisphenol and cyanate ester.

31. A thermally driven piston assembly as in claim 14 wherein said elastomeric material is selected from the group consisting of butadiene rubber, butyl rubber, chlorinated polyethylene, crosslinked polyethylene, chlorosulphonated polyethylene, epichlorohydrin-ethylene oxide, ethylene propylene diene terpolymer, ethylene-propylene rubber, EVA, natural rubber, nitrile rubber, polyacrylate, polymethylmethacrylate, polychloroprene, polyisoprene, polypropylene oxide, polyurethane, silicone, styrene butadiene rubber, and thermoplastic elastomer.

32. A thermally driven piston assembly as in claim 15 wherein said foam is a polymer foam.

9

33. A thermally driven piston assembly as in claim **32** wherein said polymer foam is selected from the group consisting of closed cell, microcellular, and open cell.

34. A thermally driven piston assembly as in claim **15** wherein said polymer is selected from the group consisting of crosslinked polymer and polyurethane.

35. A thermally driven piston assembly as in claim **34** wherein said crosslinked polymer is selected from the group consisting of polystyrene, polyvinyl chloride, polyamino acid, protein, polyethylene, polycarbonate, polyester, nylon, phenolic, polymethacrylimide, and polyethersulphone.

36. A thermally driven piston assembly as in claim **15** wherein said composite matrix is selected from the group

10

consisting of polyimide, liquid crystal polymer, epoxy, polyamide, polyaramide, polyether, and polyarylether.

37. A thermally driven piston assembly as in claim **36** wherein said liquid crystal polymer is selected from the group consisting of liquid crystal polyester and liquid crystal polyaramide.

38. A thermally driven piston assembly as in claim **36** wherein said polyether is selected from the group consisting of PEEK and PET.

39. A thermally driven piston assembly as in claim **36** wherein said polyarylether is selected from the group consisting of such as bisphenol and cyanate ester.

* * * * *