



US007603465B2

(12) **United States Patent**  
**Akashika et al.**

(10) **Patent No.:** **US 7,603,465 B2**  
(45) **Date of Patent:** **Oct. 13, 2009**

(54) **CONTROL SYSTEM AND CONTROL METHOD, METHOD AND APPARATUS FOR PROCESSING INFORMATION, INFORMATION PROCESSING TERMINAL AND METHOD THEREOF, STORAGE MEDIUM, AND PROGRAM**

(75) Inventors: **Hideki Akashika**, Tokyo (JP); **Takuya Oshima**, Tokyo (JP); **Tadashi Suzuki**, Tokoyo (JP); **Atsushi Miura**, Kanagawa (JP); **Toyokazu Ota**, Tokyo (JP); **Yoshiaki Hirano**, Kanagawa (JP)

(73) Assignee: **Sony Corporation**, Tokyo (JP)

(\*) Notice: Subject to any disclaimer, the term of this patent is extended or adjusted under 35 U.S.C. 154(b) by 788 days.

(21) Appl. No.: **10/714,869**

(22) Filed: **Nov. 18, 2003**

(65) **Prior Publication Data**

US 2004/0107246 A1 Jun. 3, 2004

(30) **Foreign Application Priority Data**

Dec. 2, 2002 (JP) ..... 2002-349994

(51) **Int. Cl.**  
**G06F 15/16** (2006.01)

(52) **U.S. Cl.** ..... **709/227; 709/208**

(58) **Field of Classification Search** ..... **709/227-228, 709/208**

See application file for complete search history.

(56) **References Cited**

**U.S. PATENT DOCUMENTS**

- 4,454,509 A \* 6/1984 Buennagel et al. .... 340/825.69
- 4,594,591 A 6/1986 Burke
- 4,761,780 A \* 8/1988 Bingham et al. .... 370/411
- 4,985,895 A 1/1991 Pelkey
- 5,886,647 A 3/1999 Badger et al.

- 5,898,835 A \* 4/1999 Truong ..... 709/217
- 6,031,990 A \* 2/2000 Sivakumar et al. .... 717/124
- 6,035,264 A \* 3/2000 Donaldson et al. .... 702/182
- 6,144,848 A 11/2000 Walsh et al.
- 6,182,149 B1 \* 1/2001 Nessett et al. .... 709/247
- 6,236,332 B1 \* 5/2001 Conkright et al. .... 340/3.1
- 6,374,298 B2 \* 4/2002 Tanno ..... 709/227
- 6,516,427 B1 \* 2/2003 Keyes et al. .... 714/25

(Continued)

**FOREIGN PATENT DOCUMENTS**

WO WO 95/20281 7/1995

**OTHER PUBLICATIONS**

Microsoft, Microsoft Computer Dictionary, 2002, Microsoft Press, 5th Ed., p. 214.\*

*Primary Examiner*—Aaron Strange

(74) *Attorney, Agent, or Firm*—Oblon, Spivak, McClelland, Maier & Neustadt, L.L.P.

(57) **ABSTRACT**

A client (such as a PC, portable telephone, PDA, electrical appliances), to which a device such as an IC card is connected, starts a handshake protocol to request a server to start communication. When communication is established via the handshake protocol, the initiative of communication is transferred to the server, and the state changes into a neutral state. In this neutral state, a control packet including a particular number of messages and a finished message is transmitted from the server to the client. If the client receives the control packet, the client performs a process according to the messages included in the control packet. This makes it possible to remotely control a device via a network in a highly reliable and efficient manner.

**16 Claims, 24 Drawing Sheets**

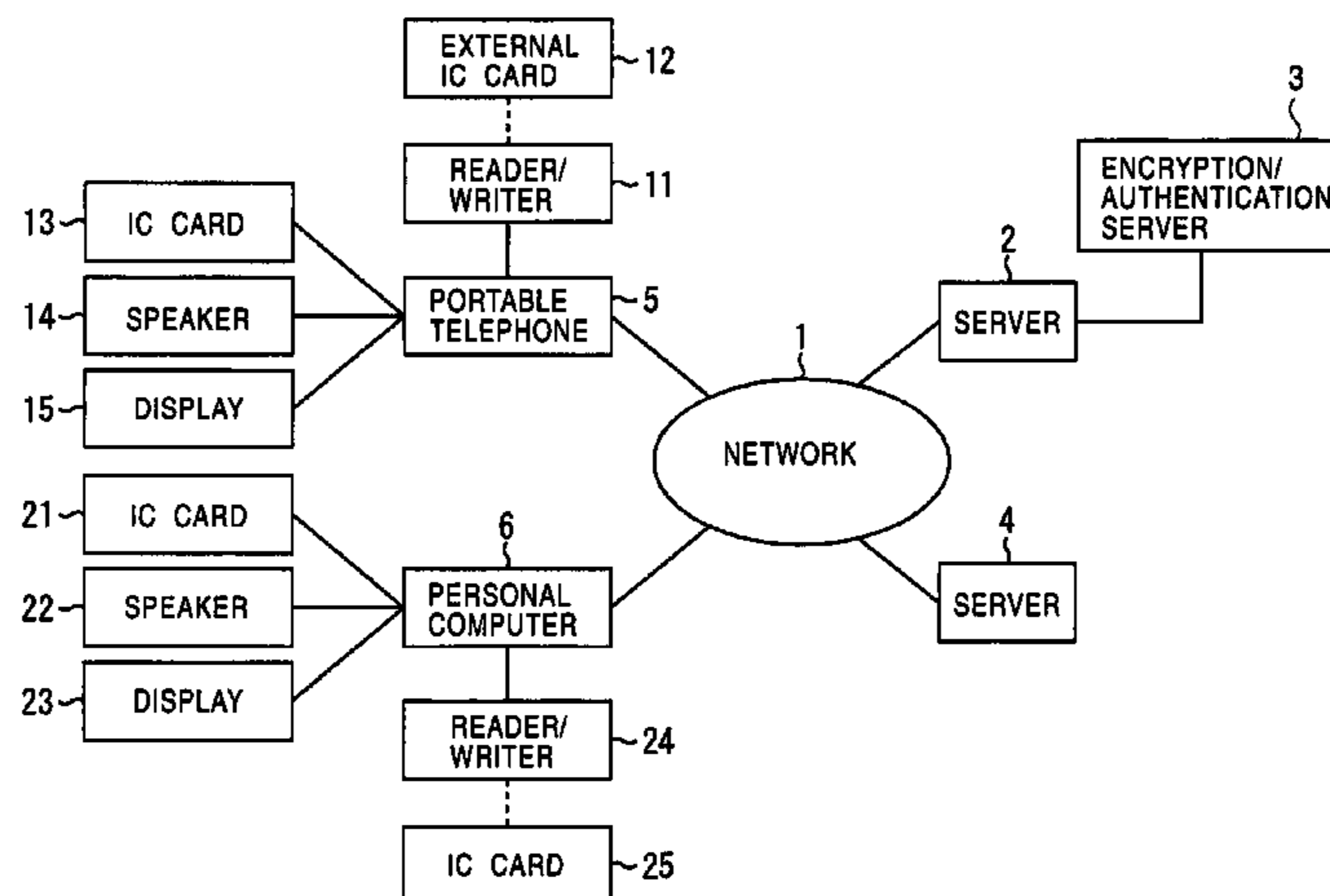

# US 7,603,465 B2

Page 2

---

## U.S. PATENT DOCUMENTS

6,553,422	B1 *	4/2003	Nelson	.....	709/227	2002/0080782	A1 *	6/2002	Dick et al.	.....	370/362
6,597,393	B2 *	7/2003	Kato et al.	.....	348/211.99	2002/0122205	A1 *	9/2002	Gauthier	.....	358/1.15
6,625,147	B1 *	9/2003	Yokoyama et al.	.....	370/389	2002/0143954	A1 *	10/2002	Aiken et al.	.....	709/227
6,782,426	B1 *	8/2004	Kuroshima et al.	.....	709/229	2004/0054789	A1 *	3/2004	Breh et al.	.....	709/229
7,007,070	B1 *	2/2006	Hickman	.....	709/208	2005/0012960	A1 *	1/2005	Eden et al.	.....	358/1.18
7,130,888	B1 *	10/2006	Hickman et al.	.....	709/208	2006/0168260	A1 *	7/2006	Hinde et al.	.....	709/229

\* cited by examiner

FIG. 1

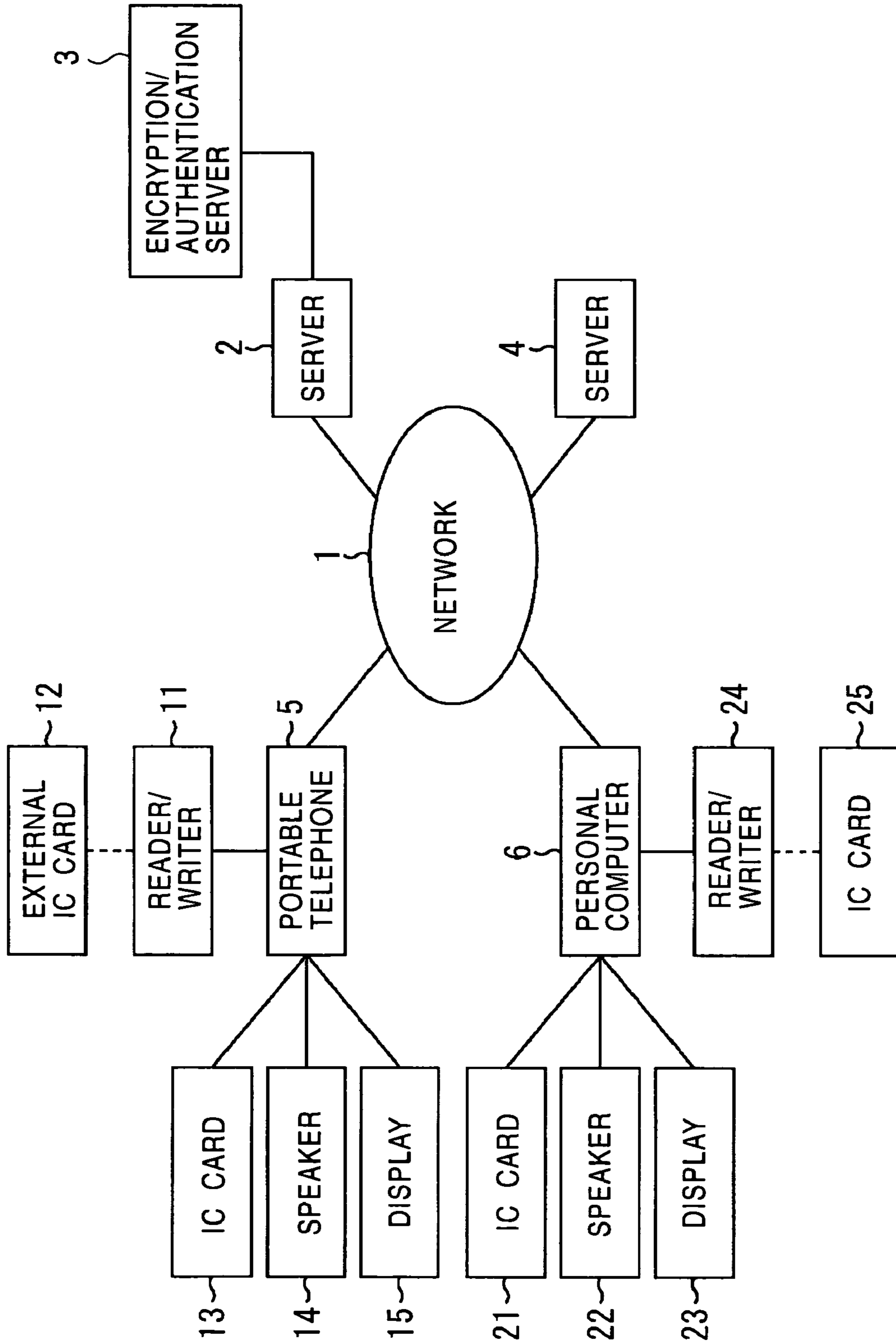

FIG. 2

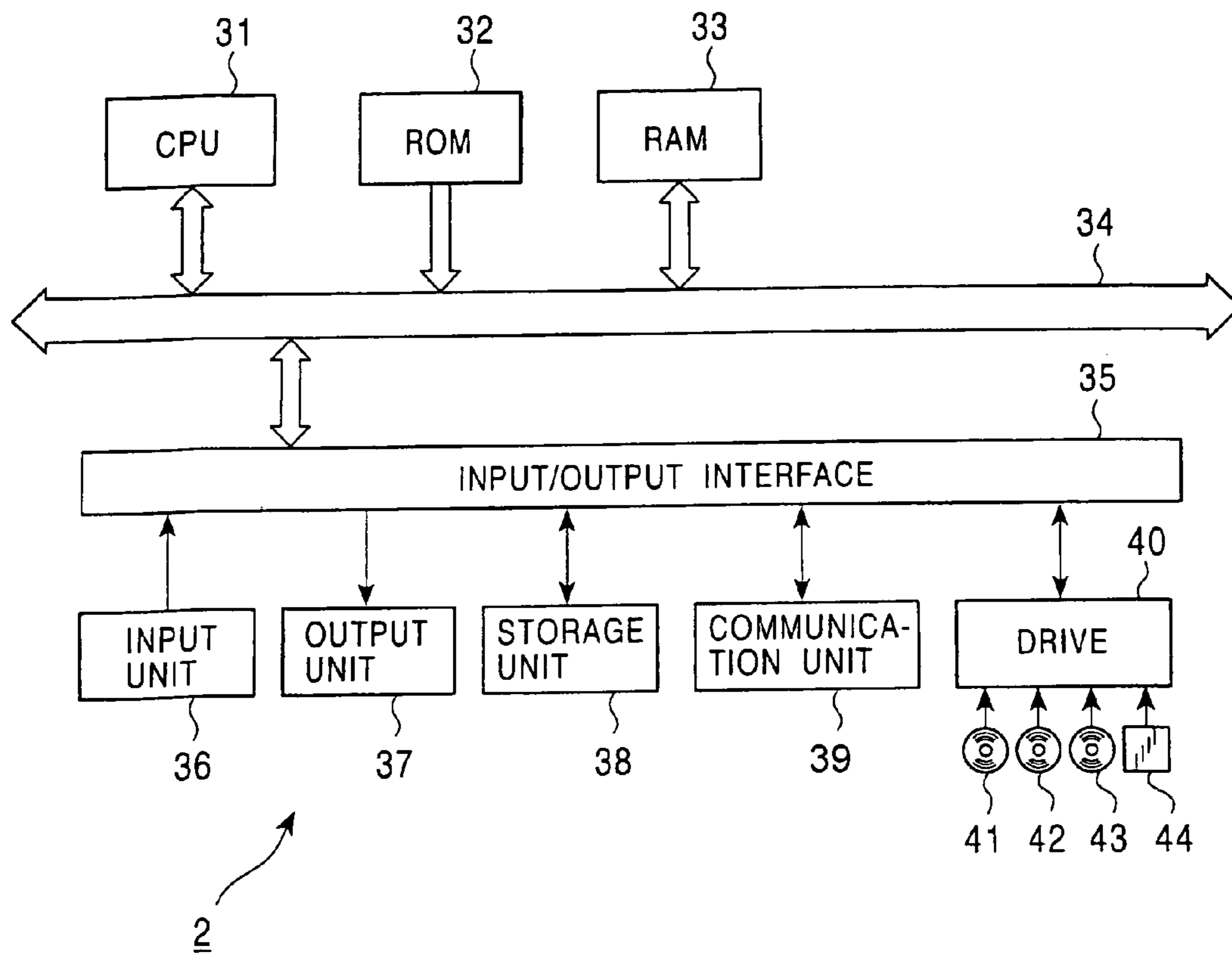
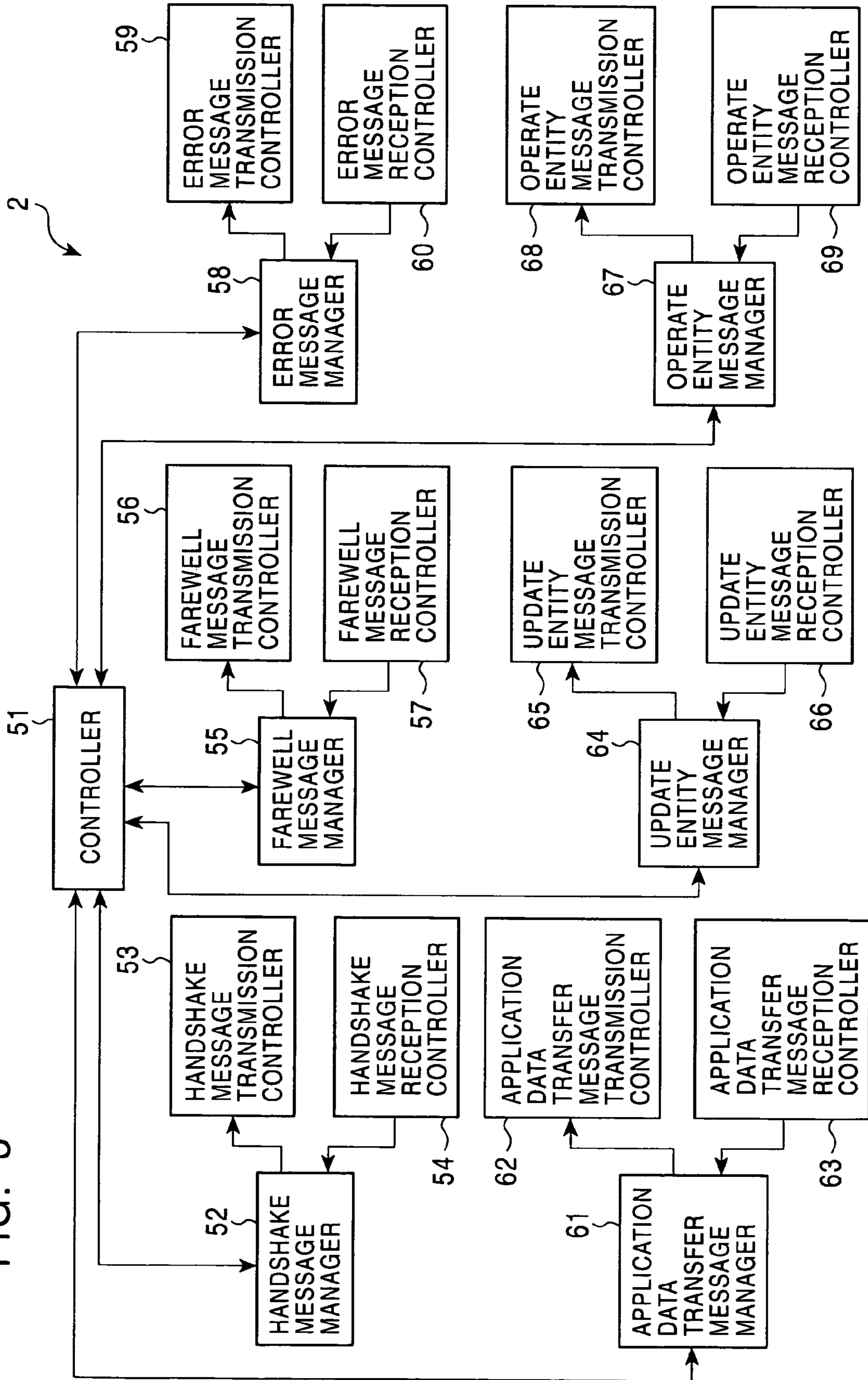

FIG. 3



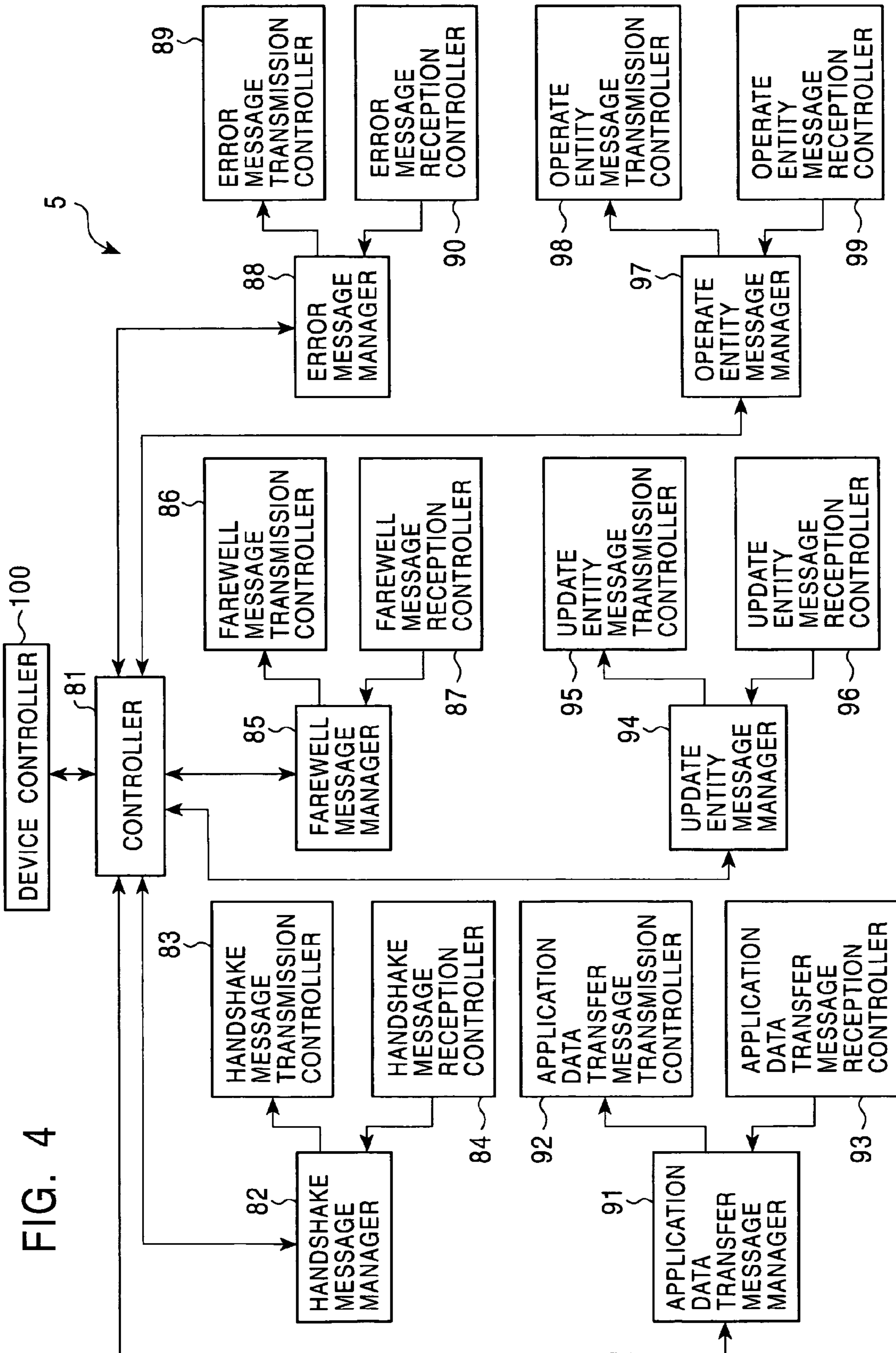

FIG. 4

FIG. 5

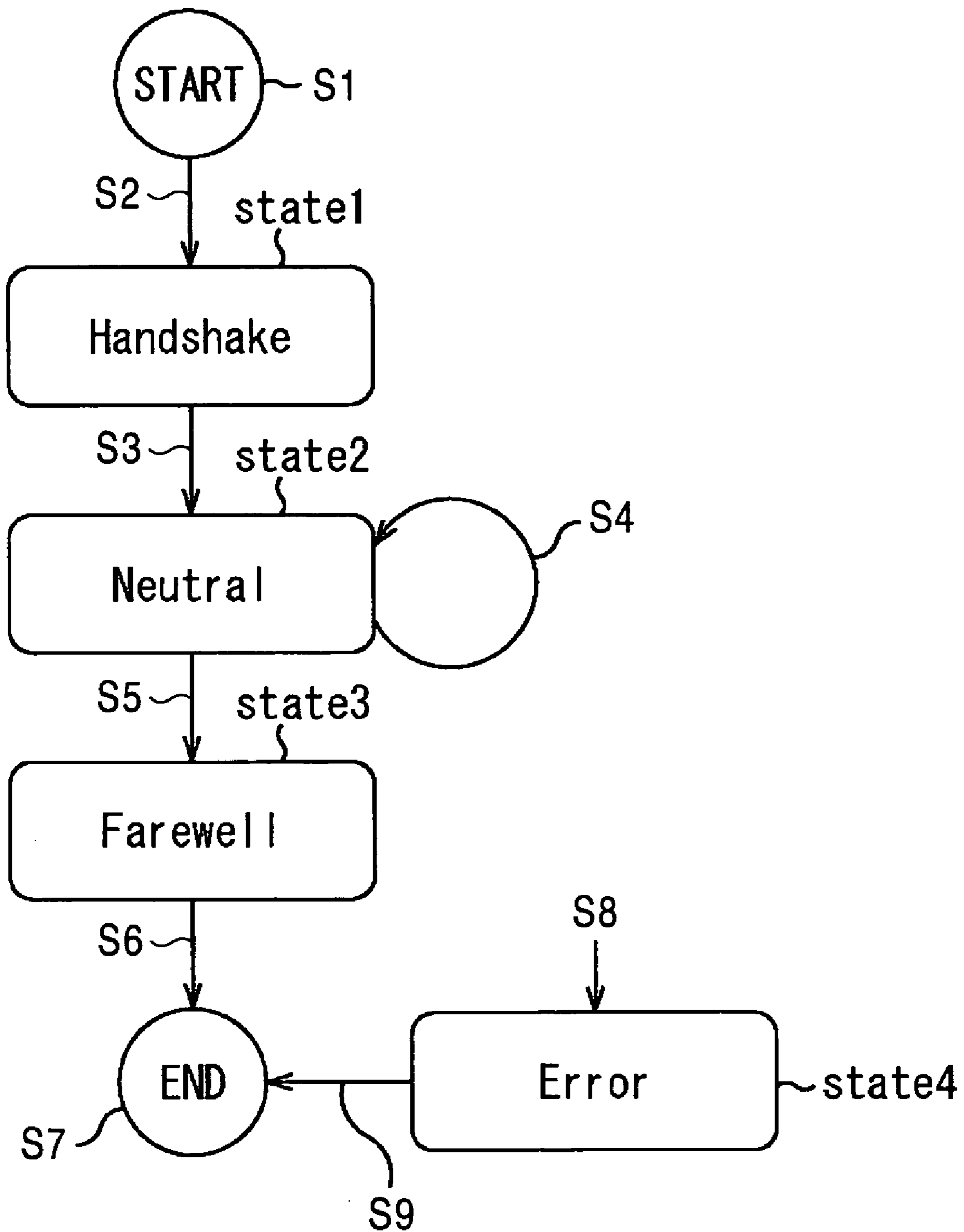

FIG. 6

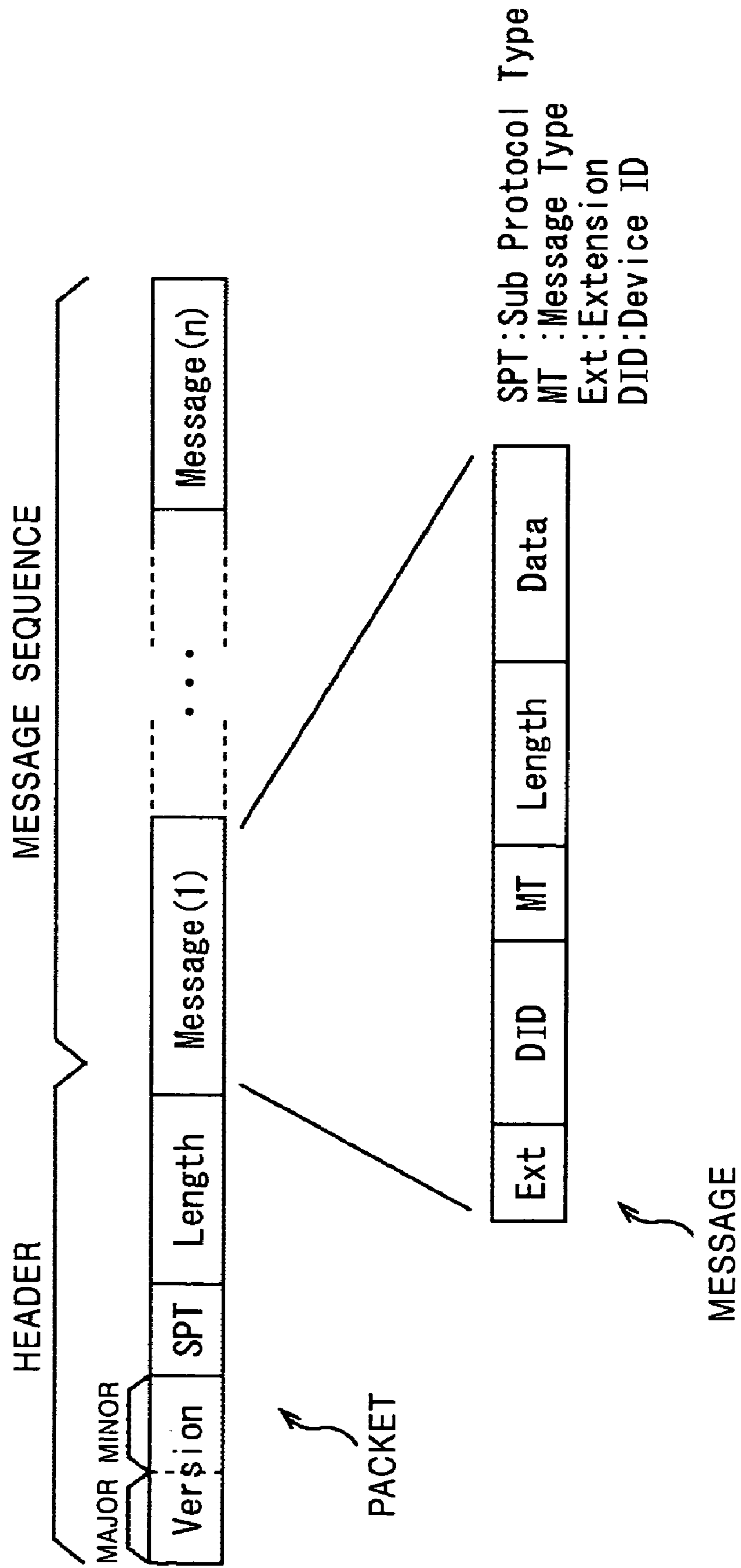



FIG. 7

HANDSHAKE PROTOCOL		
MESSAGE NAME	DESCRIPTION	DATA PART
FINISHED	END OF SUB-PROTOCOL	NONE
WARNING	WARNING	WARNING MESSAGE: CHARACTER STRING
CLIENT_HELLO	START OF TRANSMISSION OF HANDSHAKE DATA ADDRESSED TO SERVER	NONE
CLIENT_HELLO_DONE	END OF TRANSMISSION OF HANDSHAKE DATA ADDRESSED TO SERVER	NONE
SERVER_HELLO	START OF TRANSMISSION OF HANDSHAKE DATA ADDRESSED TO CLIENT	NONE
SERVER_HELLO_DONE	END OF TRANSMISSION OF HANDSHAKE DATA ADDRESSED TO CLIENT	NONE
DEVICES	NOTICE OF DEVICE LIST	<ul style="list-style-type: none"> <li>• DEVICE ID</li> <li>• PERMISSION</li> <li>• TYPE NAME LENGTH</li> <li>• TYPE NAME</li> <li>• DEVICE NAME LENGTH</li> <li>• DEVICE NAME</li> </ul>

FIG. 8

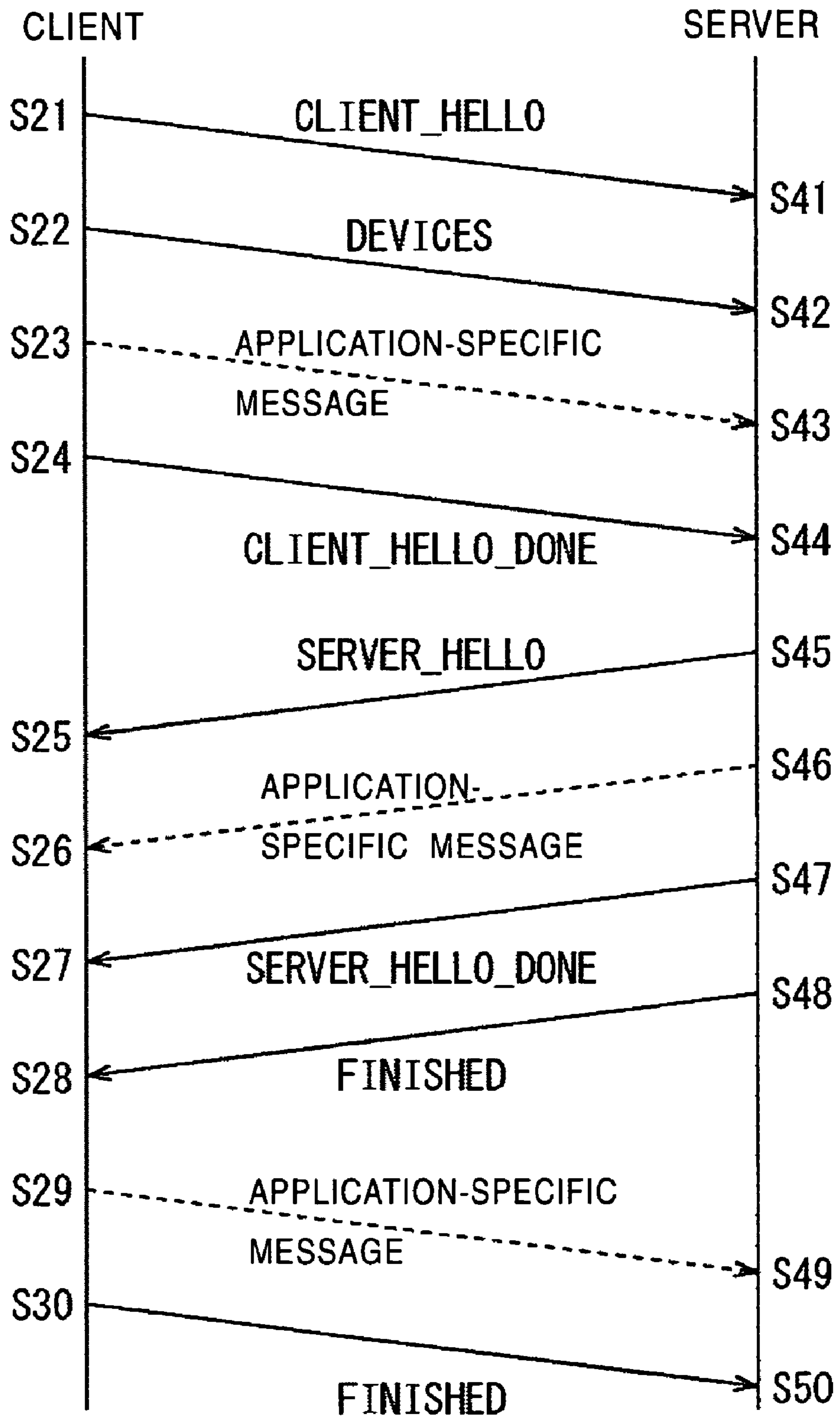

FIG. 9

FAREWELL PROTOCOL		
MESSAGE NAME	DESCRIPTION	DATA PART
FINISHED	END OF SUB-PROTOCOL	NONE
WARNING	WARNING	WARNING MESSAGE: CHARACTER STRING
CLIENT_GOOD_BYE	START OF TRANSMISSION OF FAREWELL DATA ADDRESSED TO SERVER	NONE
CLIENT_GOOD_BYE_ DONE	END OF TRANSMISSION OF FAREWELL DATA ADDRESSED TO SERVER	NONE
SERVER_GOOD_BYE	START OF TRANSMISSION OF FAREWELL DATA ADDRESSED TO CLIENT	NONE
SERVER_GOOD_BYE_ DONE	END OF TRANSMISSION OF FAREWELL DATA ADDRESSED TO CLIENT	NONE
RETURN_CODE	NOTICE OF SERVER END CODE	END CODE

FIG. 10

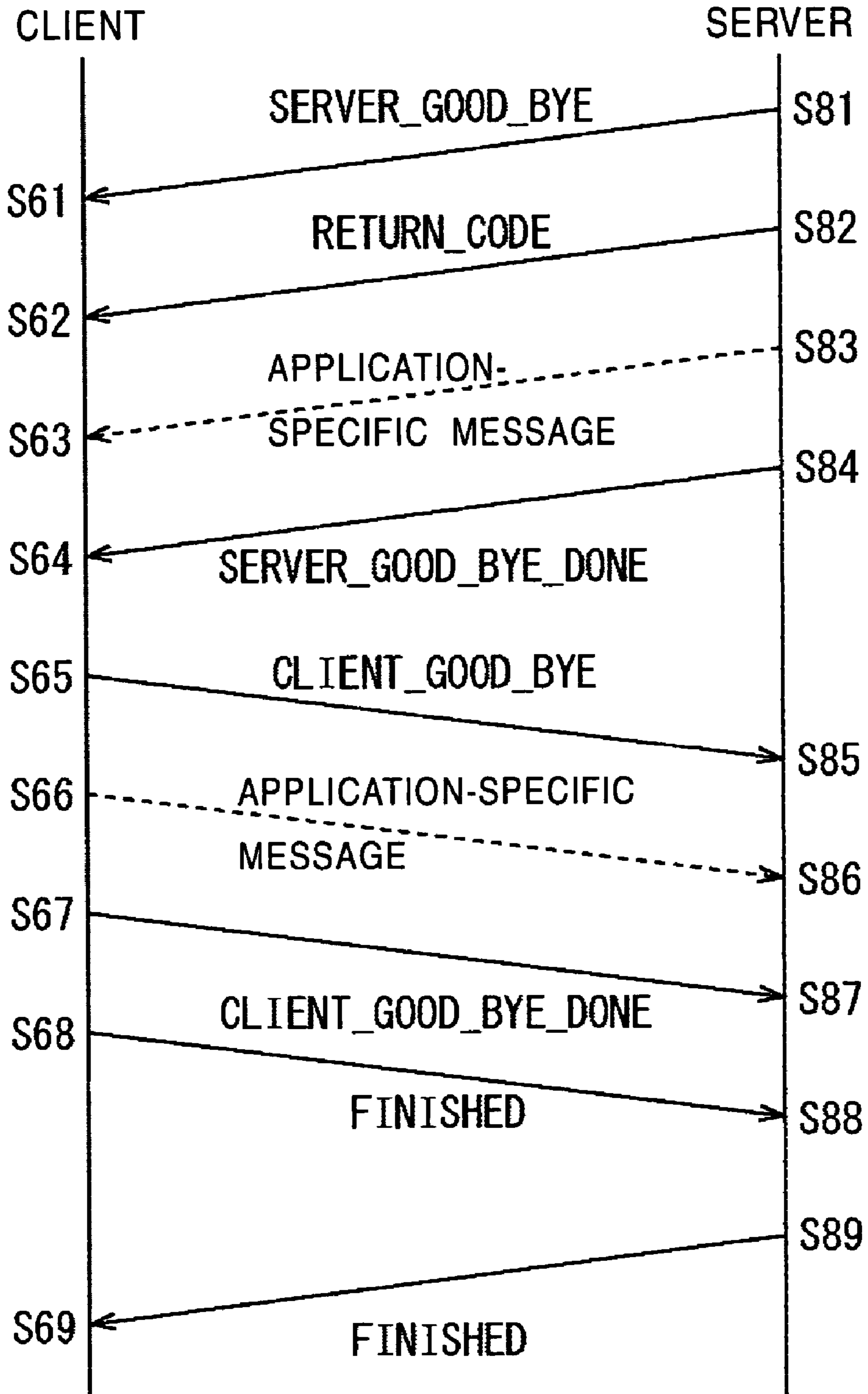

FIG. 11

ERROR PROTOCOL		
MESSAGE NAME	DESCRIPTION	DATA PART
FINISHED	END OF SUB-PROTOCOL	NONE
WARNING	WARNING	WARNING MESSAGE: CHARACTER STRING
PACKET_FORMAT_ERROR	FORMAT ERROR	ERROR MESSAGE: CHARACTER STRING
ILLEGAL_STATE_ERROR	ILLEGAL STATE ERROR DETECTED	ERROR MESSAGE: CHARACTER STRING
UNEXPECTED_ERROR	UNEXPECTED ERROR OCCURRED	ERROR MESSAGE: CHARACTER STRING

FIG. 12

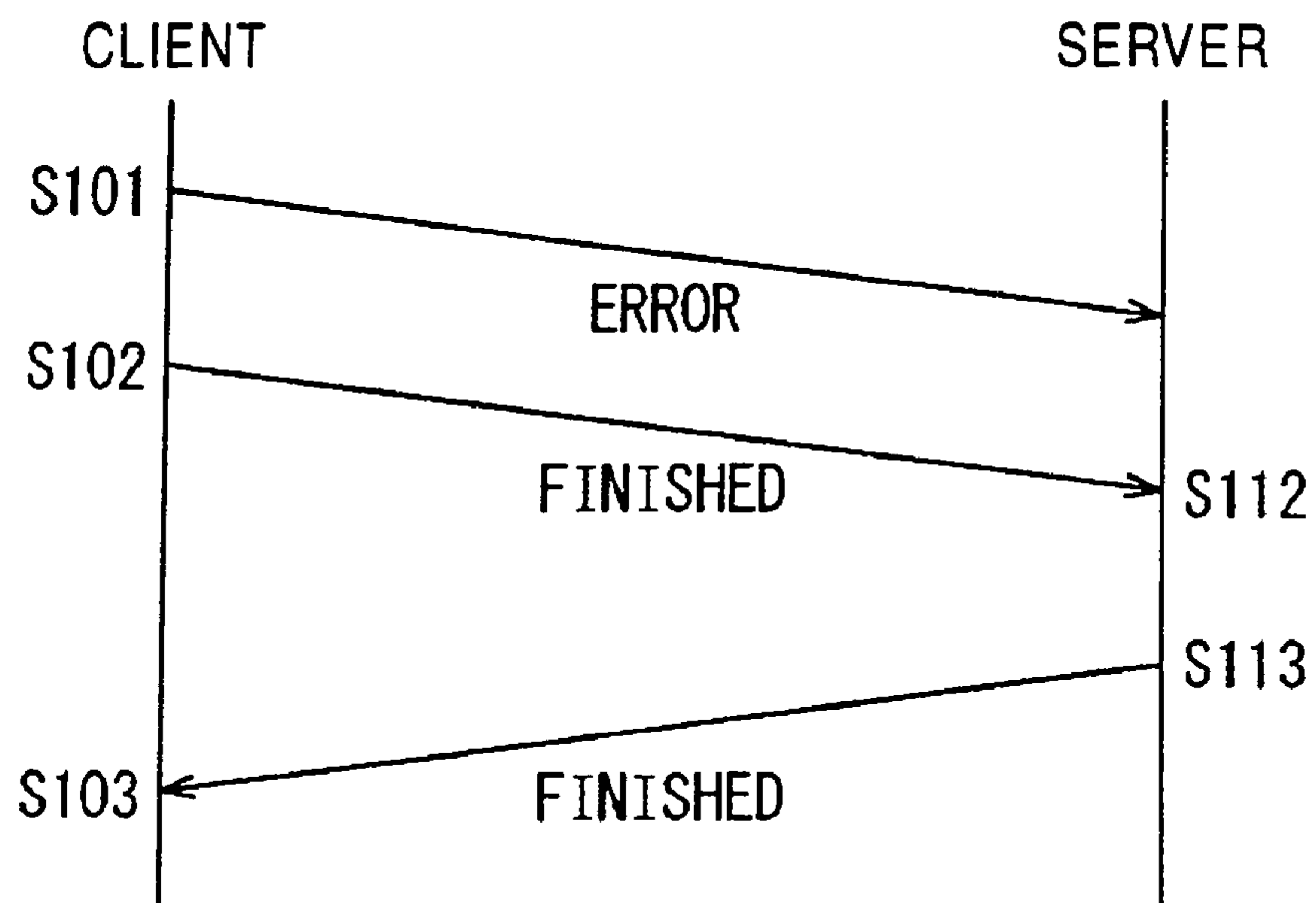

FIG. 13

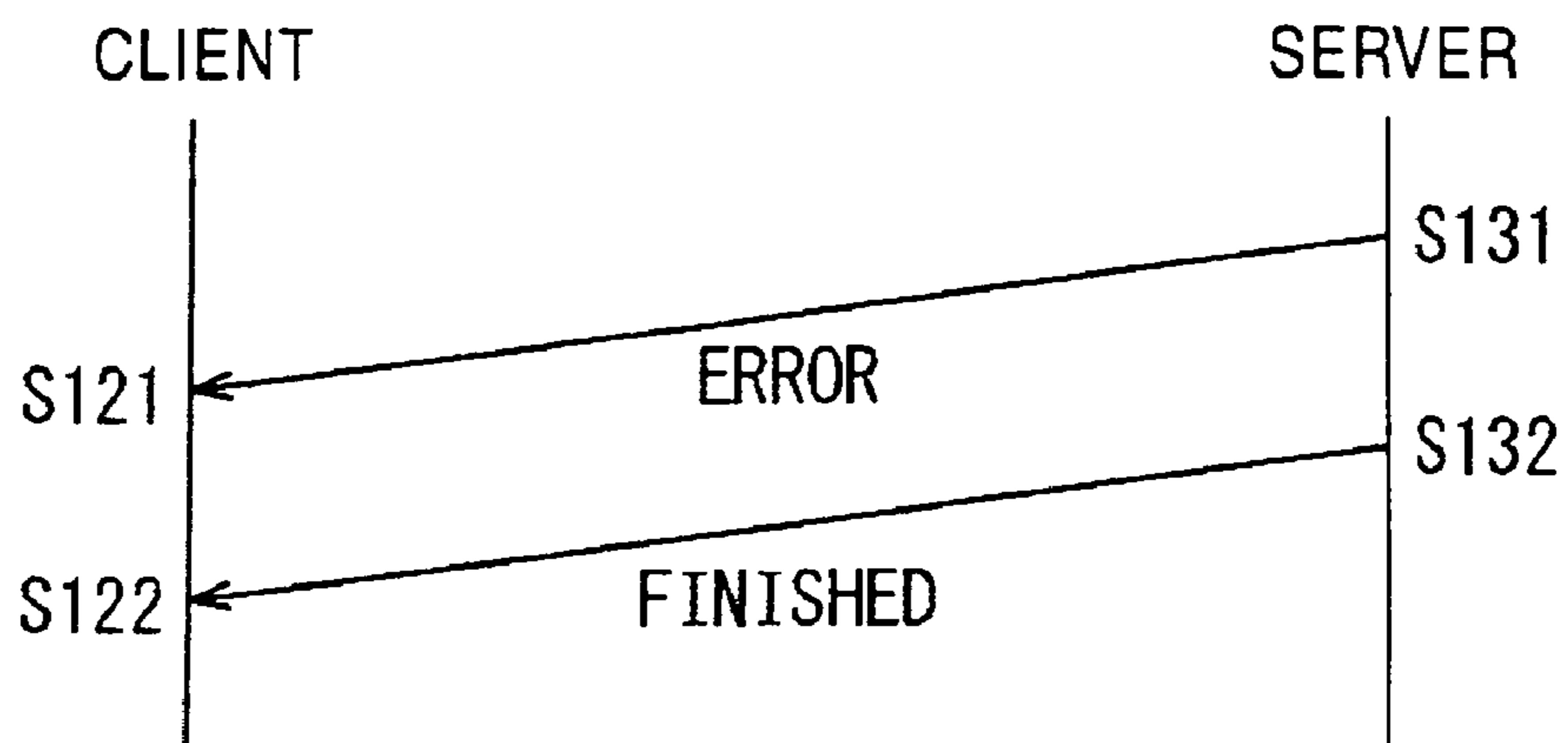

FIG. 14

UPDATE ENTITY PROTOCOL		
MESSAGE NAME	DESCRIPTION	DATA PART
FINISHED	END OF PACKET	NONE
WARNING	WARNING	WARNING MESSAGE: CHARACTER STRING
SET_PROPERTY	SET PROPERTY OF CLIENT DEVICE RESPONSE: PROPERTY_SET WHEN FAILED: TERMINATE	<ul style="list-style-type: none"> <li>• PROPERTY NAME LENGTH</li> <li>• PROPERTY NAME</li> <li>• PROPERTY LENGTH</li> <li>• PROPERTY</li> </ul>
PROPERTY_SET	RESPONSE TO PROPERTY_SET	SUCCESS FLAG
GET_PROPERTY	GET PROPERTY OF CLIENT DEVICE RESPONSE: PROPERTY_SET WHEN FAILED: TERMINATE	<ul style="list-style-type: none"> <li>• PROPERTY NAME LENGTH</li> <li>• PROPERTY NAME</li> </ul>
PROPERTY	RESPONSE TO GET_PROPERTY	<ul style="list-style-type: none"> <li>• PROPERTY LENGTH</li> <li>• PROPERTY</li> </ul>
SET_NETWORK_TIMEOUT	SET NETWORK TIMEOUT VALUE OF CLIENT RESPONSE: NONE WHEN FAILED: CONTINUE	<ul style="list-style-type: none"> <li>• TIMEOUT VALUE (msec)</li> </ul>

FIG. 15

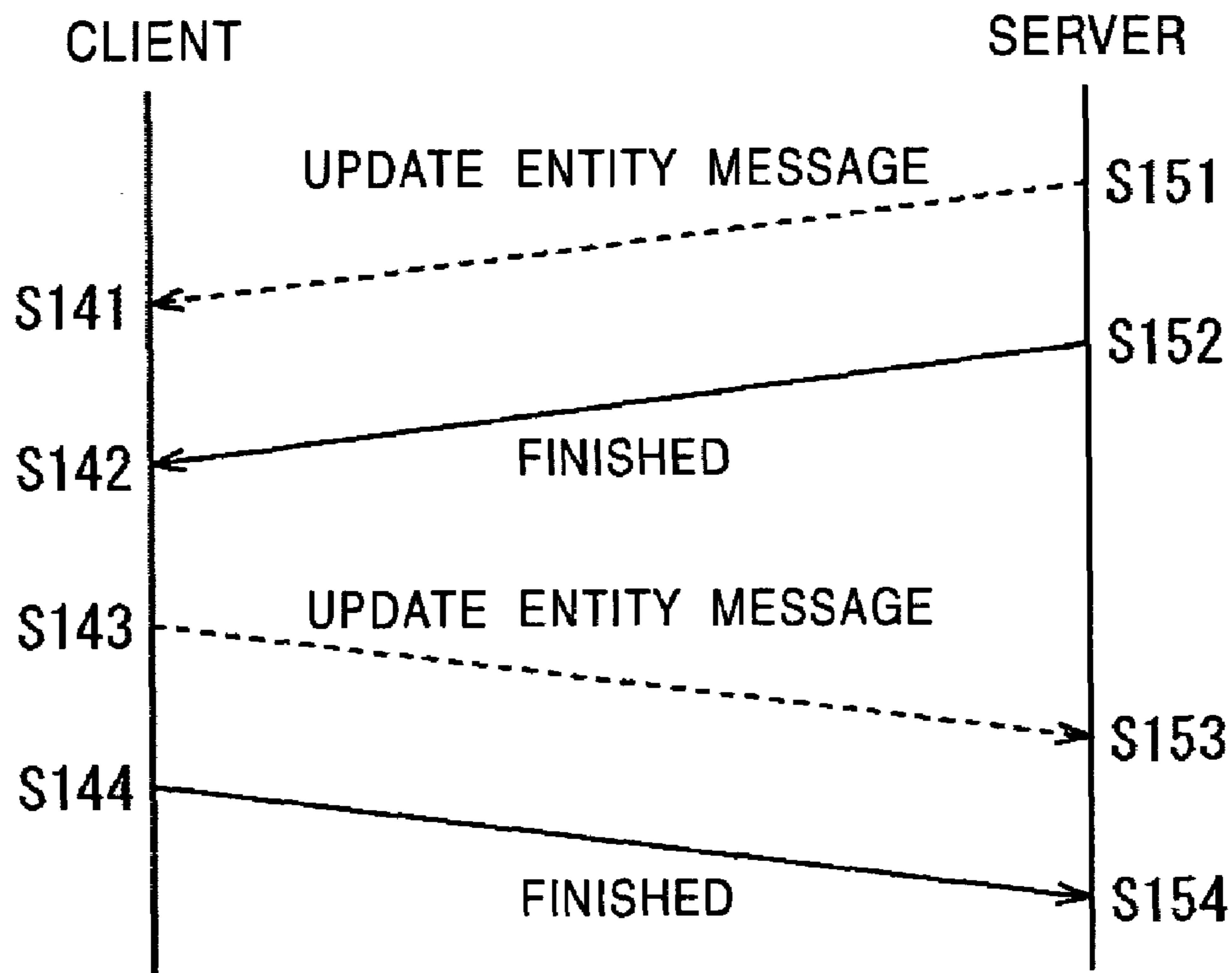

FIG. 16

APPLICATION DATA TRANSFER PROTOCOL	
MESSAGE NAME	DESCRIPTION
FINISHED	END OF PACKET
WARNING	WARNING



FIG. 17

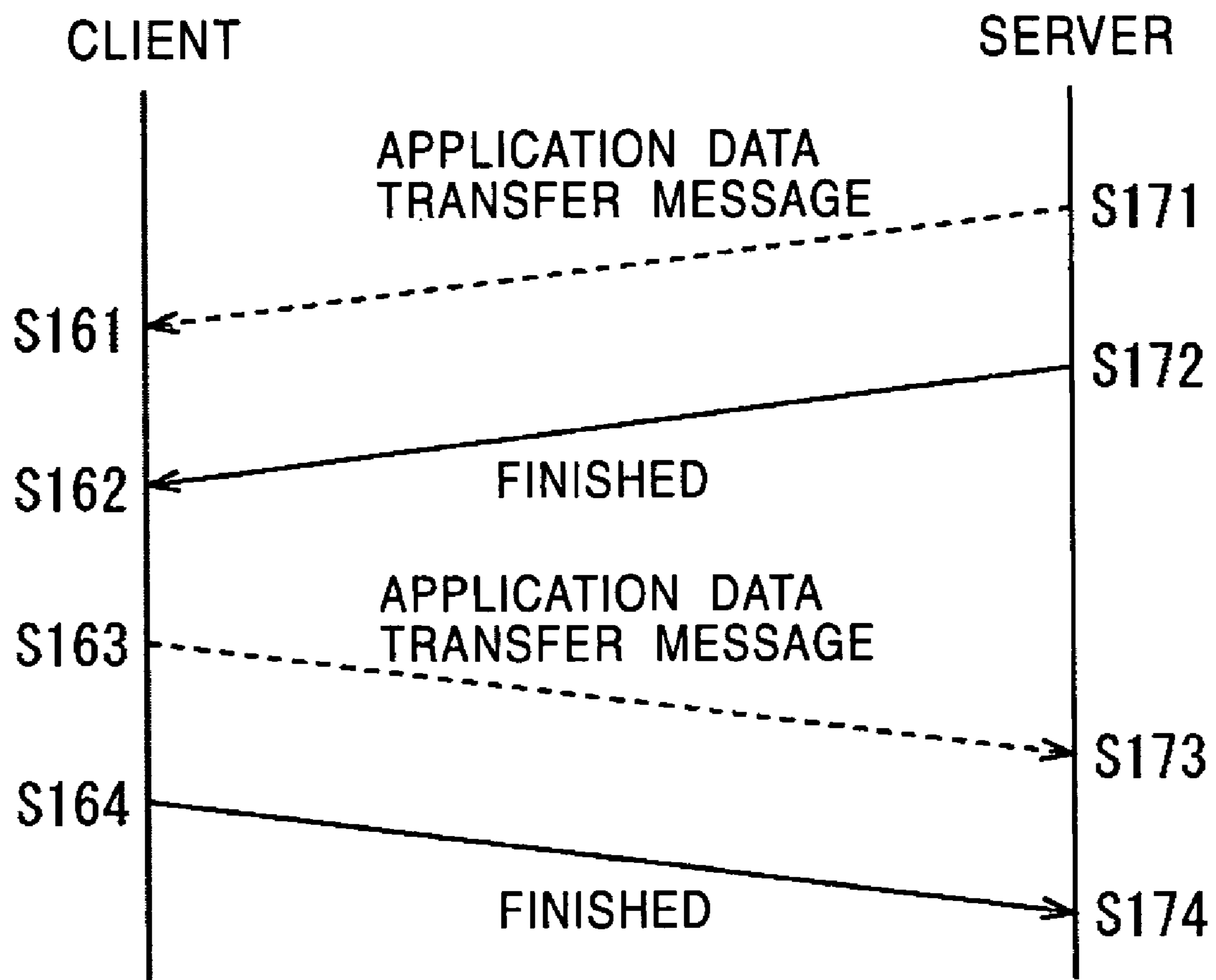
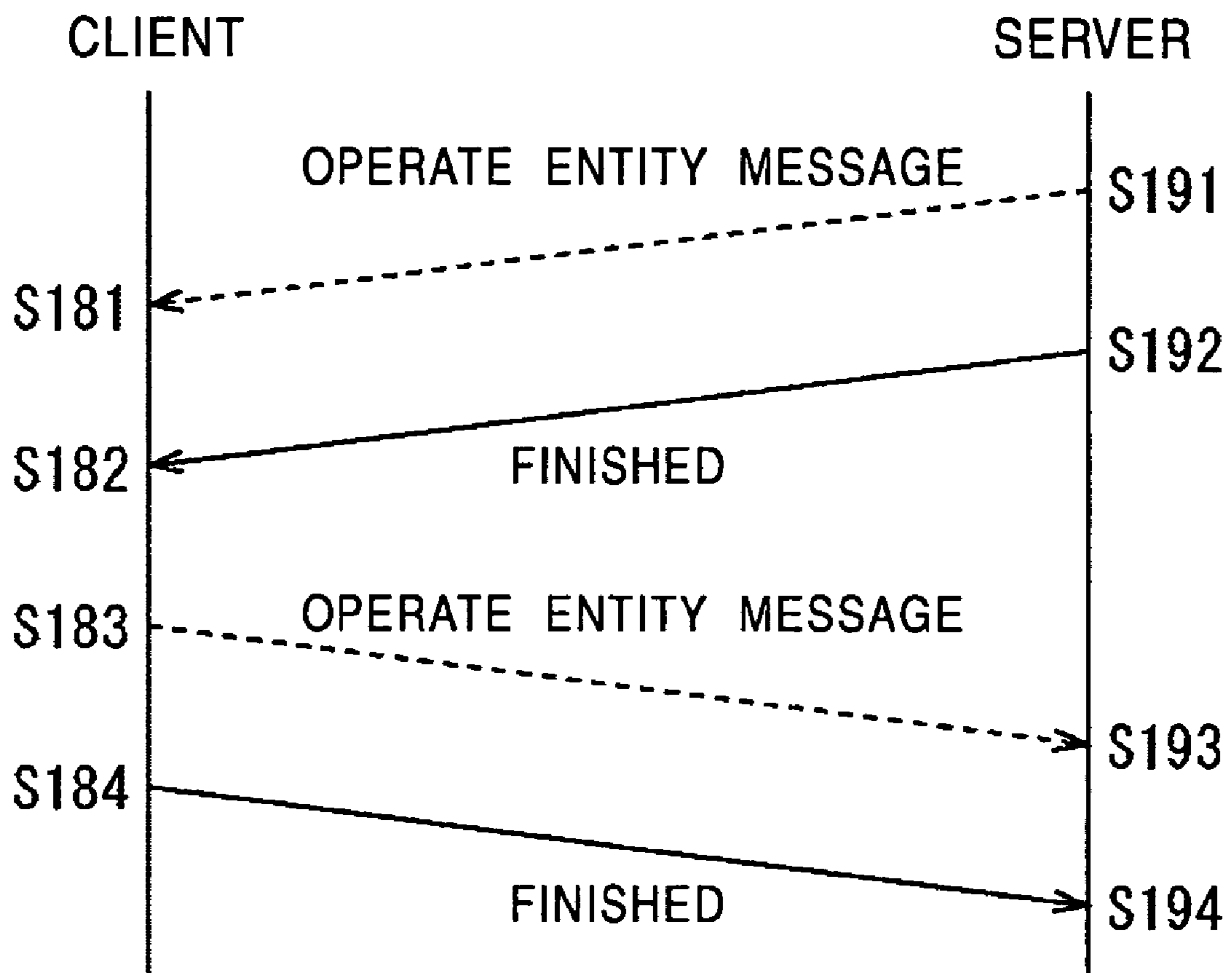

FIG. 18

OPERATE ENTITY PROTOCOL		DATA PART
MESSAGE NAME	DESCRIPTION	
FINISHED	END OF PACKET	NONE
WARNING	WARNING	WARNING MESSAGE: CHARACTER STRING
UPDATE_VIEW	UPDATE OF VIEW RESPONSE: VIEW_UPDATED WHEN FAILED: TERMINATE	NONE
VIEW_UPDATED	RESPONSE TO UPDATE_VIEW	SUCCESS FLAG
BEGIN_DATA_INPUT	BEGIN DATA INPUT RESPONSE: END_DATA_INPUT WHEN FAILED: TERMINATE	NONE
END_DATA_INPUT	RESPONSE TO BEGIN_DATA_INPUT	<ul style="list-style-type: none"> <li>• SUCCESS FLAG</li> <li>• PROPERTY NAME LENGTH</li> <li>• PROPERTY NAME</li> <li>• PROPERTY LENGTH</li> <li>• PROPERTY</li> </ul>
OPERATE_DEVICE	OPERATE CLIENT DEVICE RESPONSE: DEVICE_RESPONSE WHEN FAILED: TERMINATE	<ul style="list-style-type: none"> <li>• NUMBER OF CHARACTERS OF OPERATION NAME</li> <li>• OPERATION NAME</li> <li>• PARAMETER LENGTH</li> <li>• PARAMETER</li> </ul>
DEVICE_RESPONSE	RESPONSE TO DEVICE OPERATION	<ul style="list-style-type: none"> <li>• RESPONSE LENGTH</li> <li>• RESPONSE</li> </ul>
PLAY_SOUND	PRODUCE SOUND CORRESPONDING TO PHYSICAL NAME SPECIFIED BY CLIENT RESPONSE: NONE WHEN FAILED: CONTINUE	PHYSICAL NAME OF SOUND: CHARACTER STRING

FIG. 19



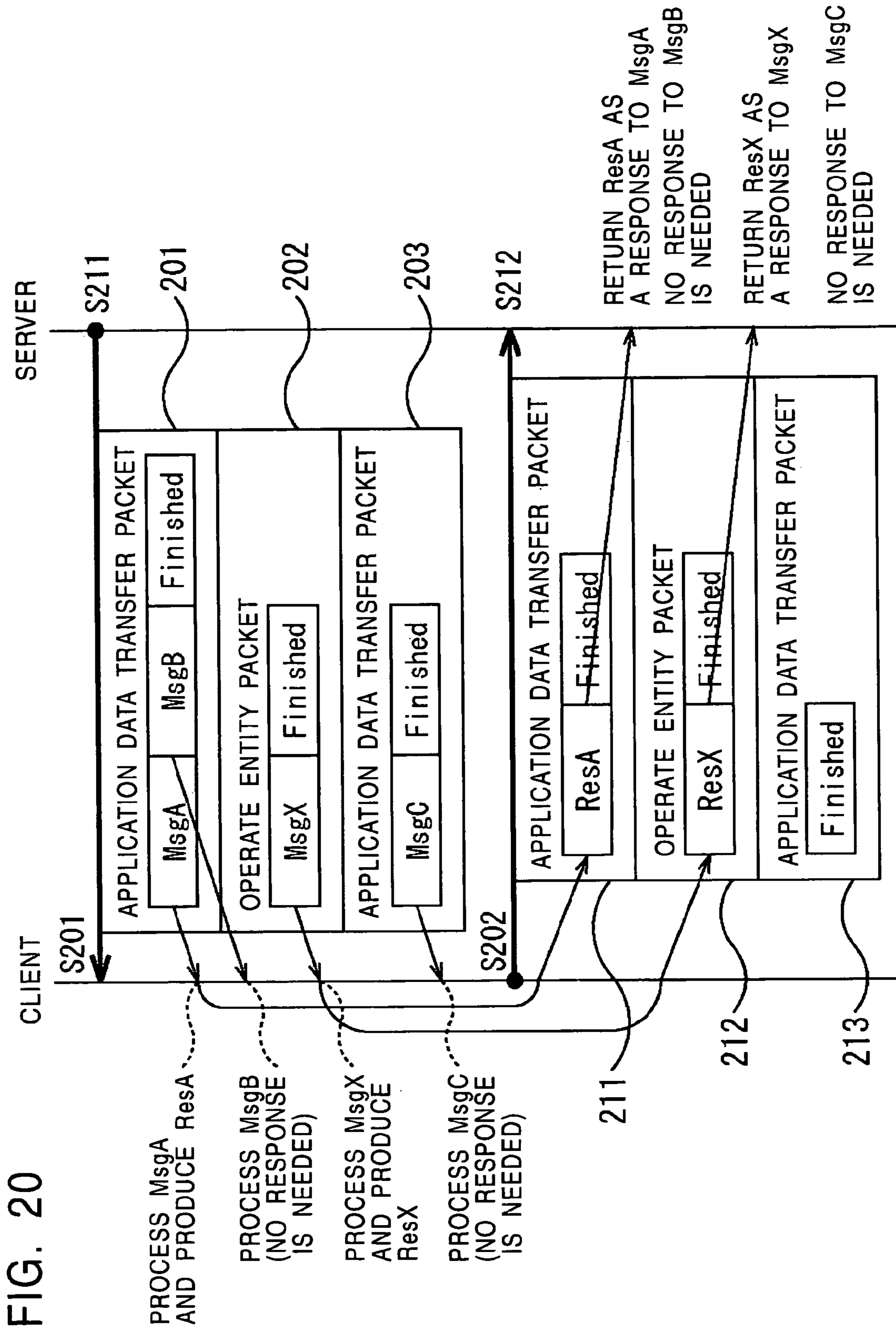

FIG. 21

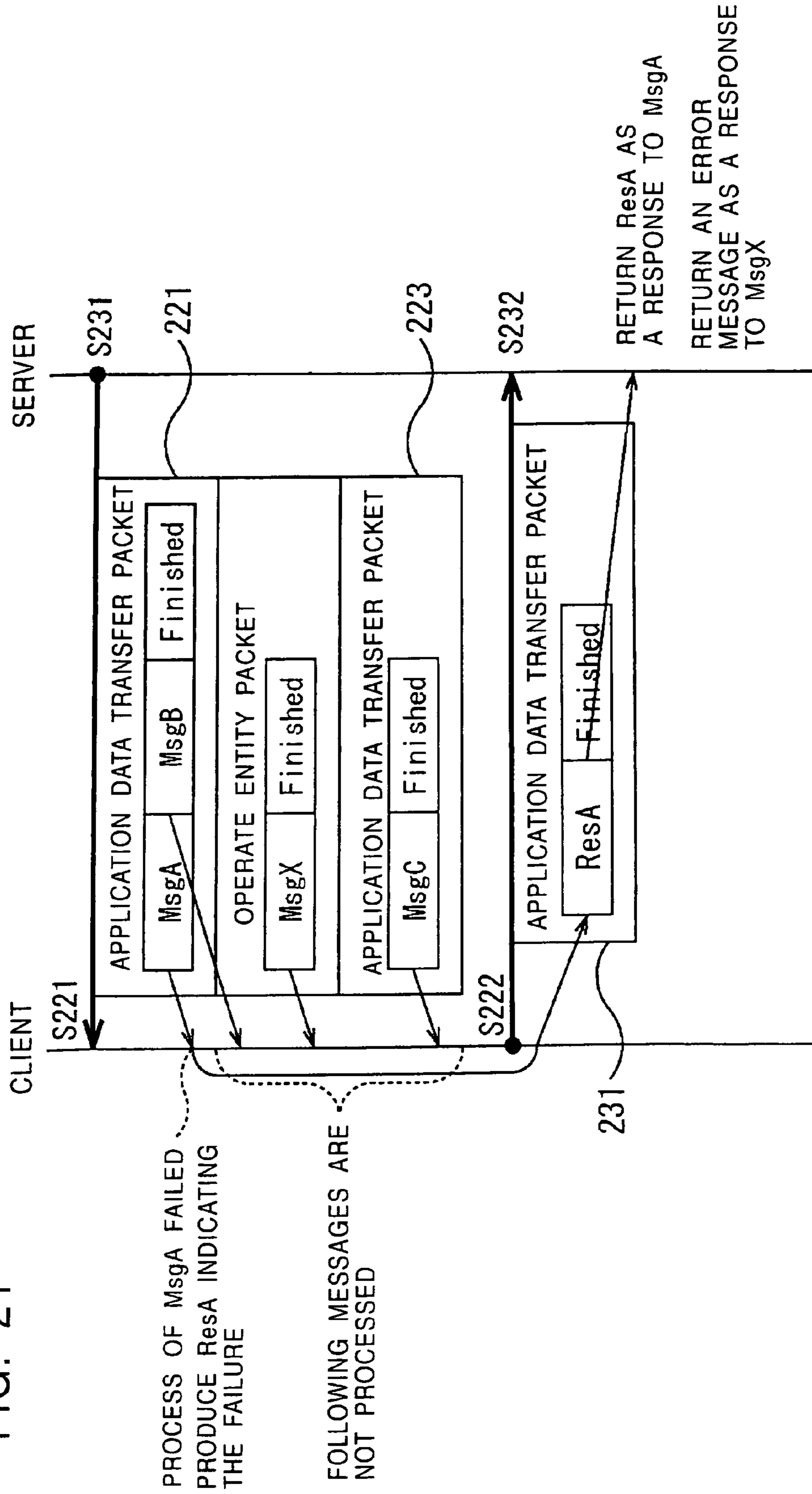

FIG. 22

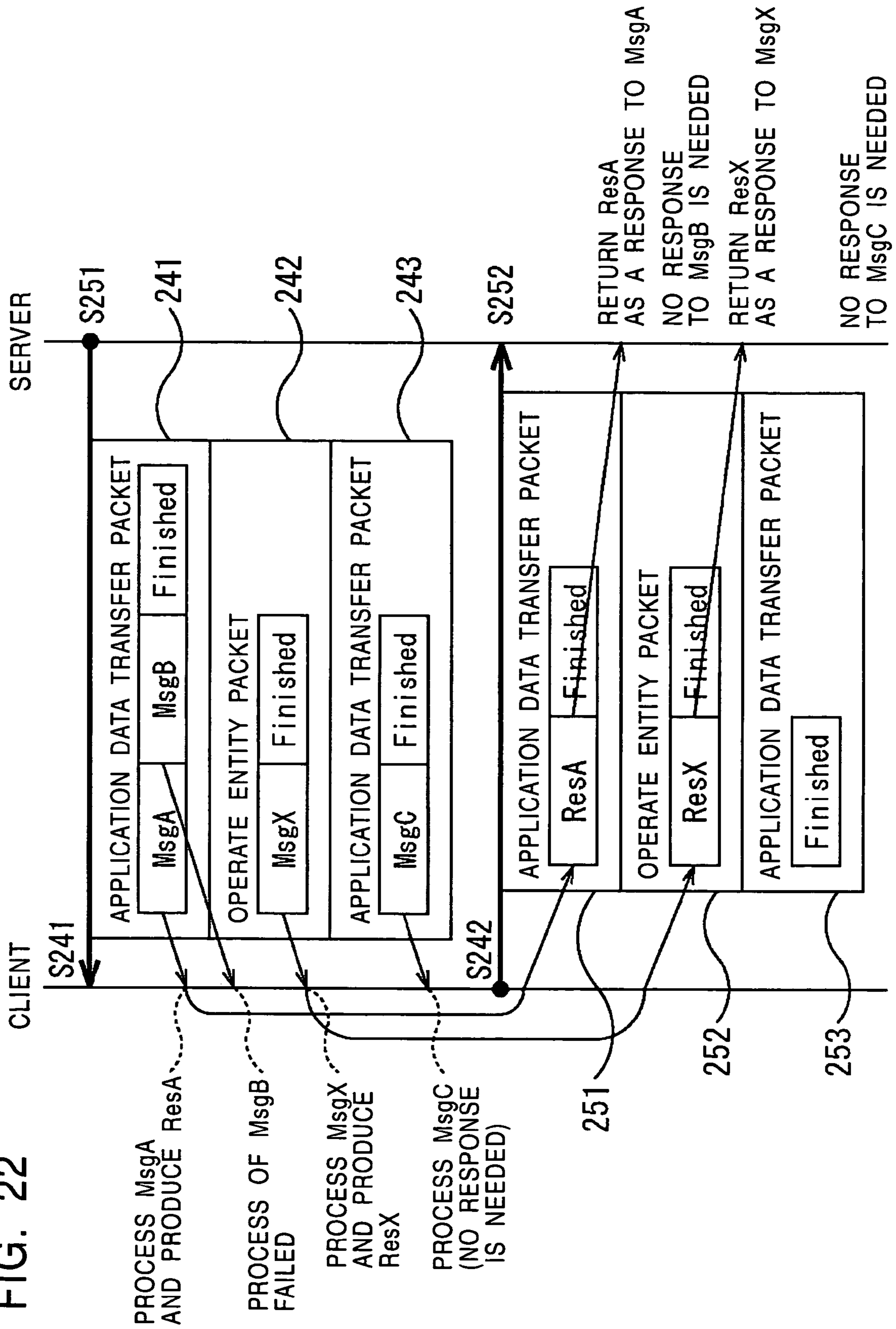

FIG. 23

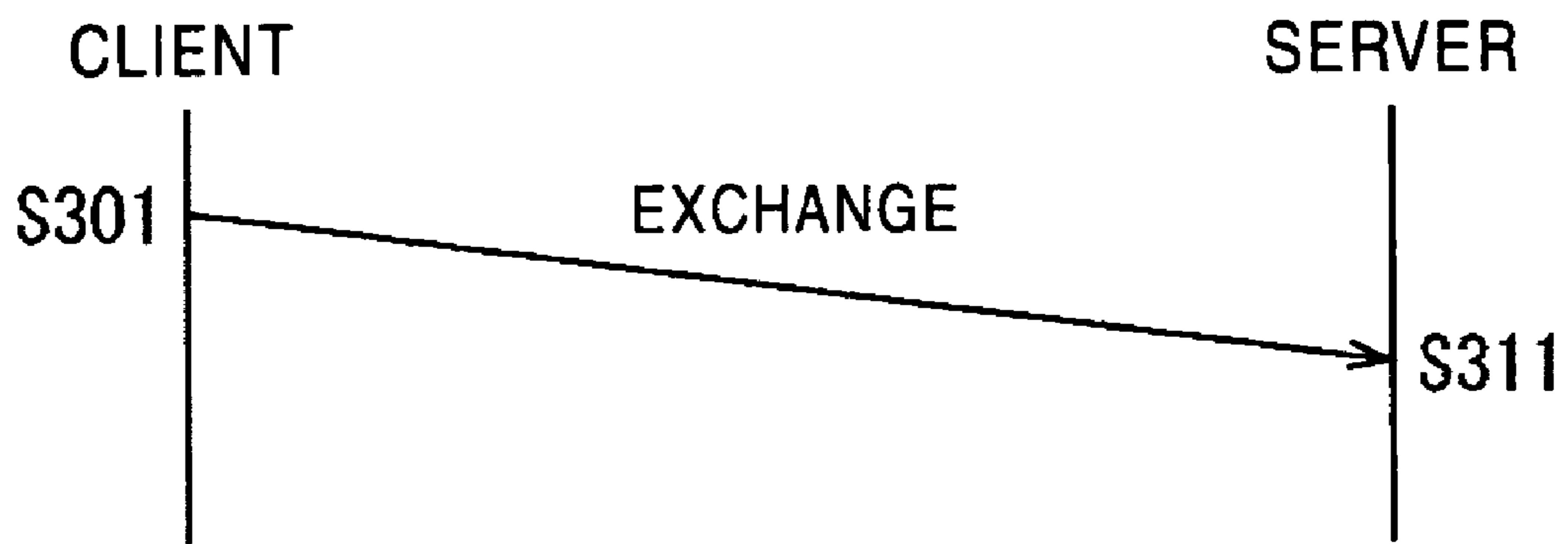

FIG. 24

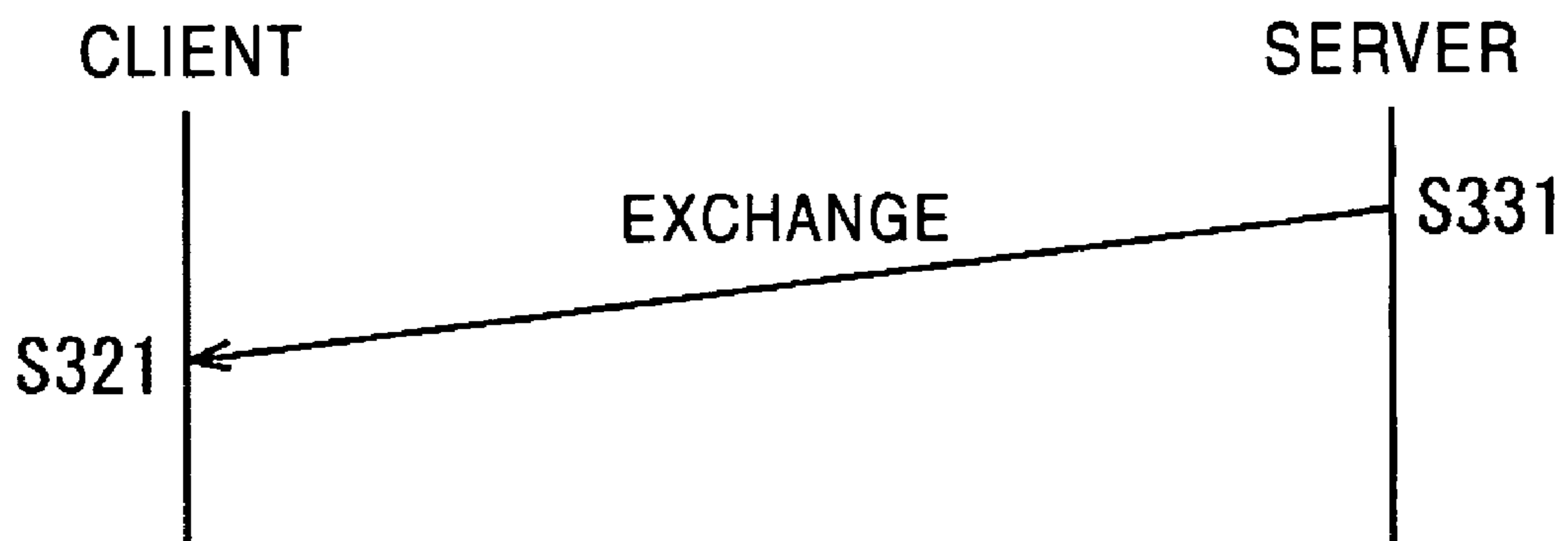

FIG. 25

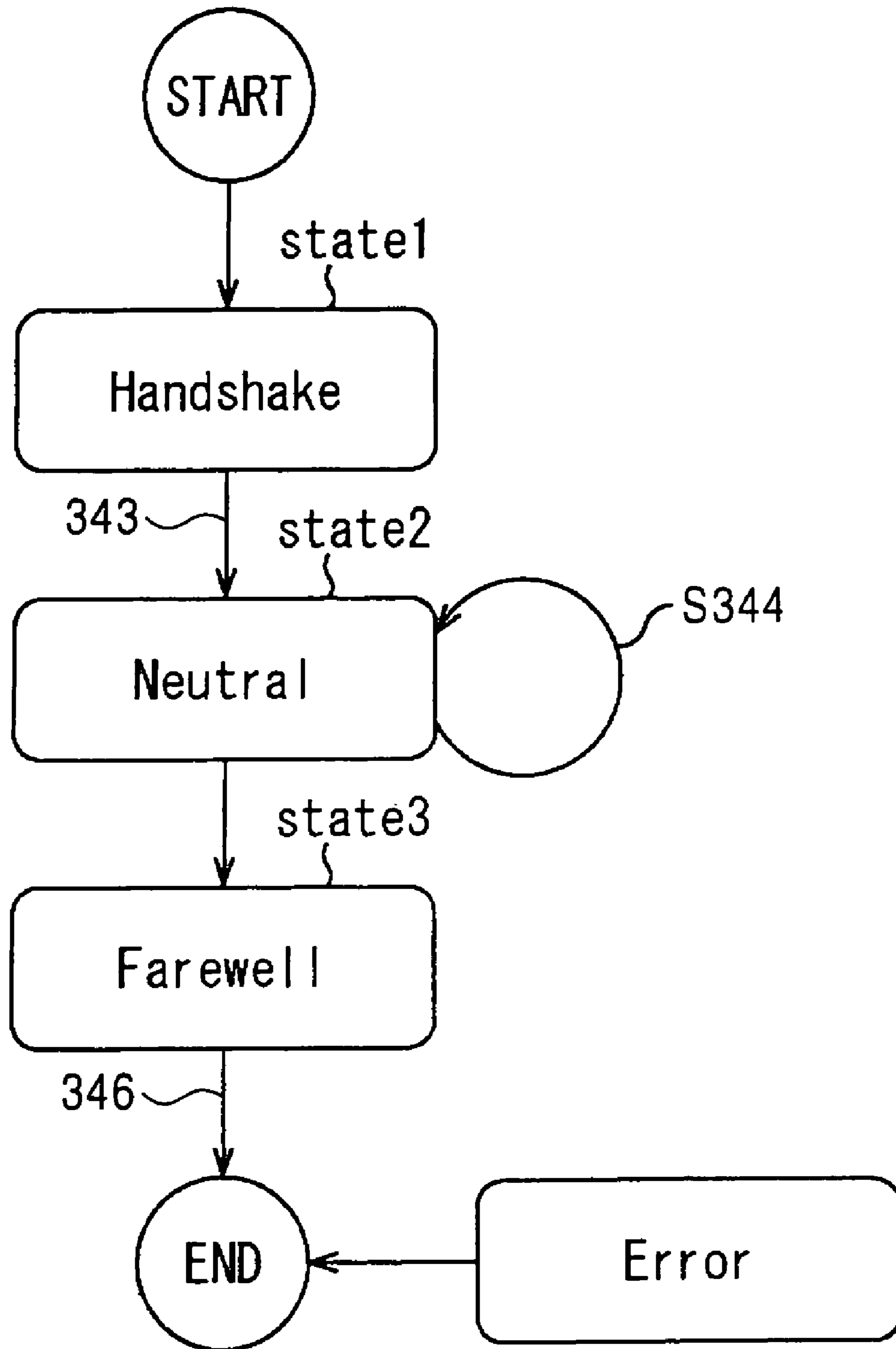



FIG. 26

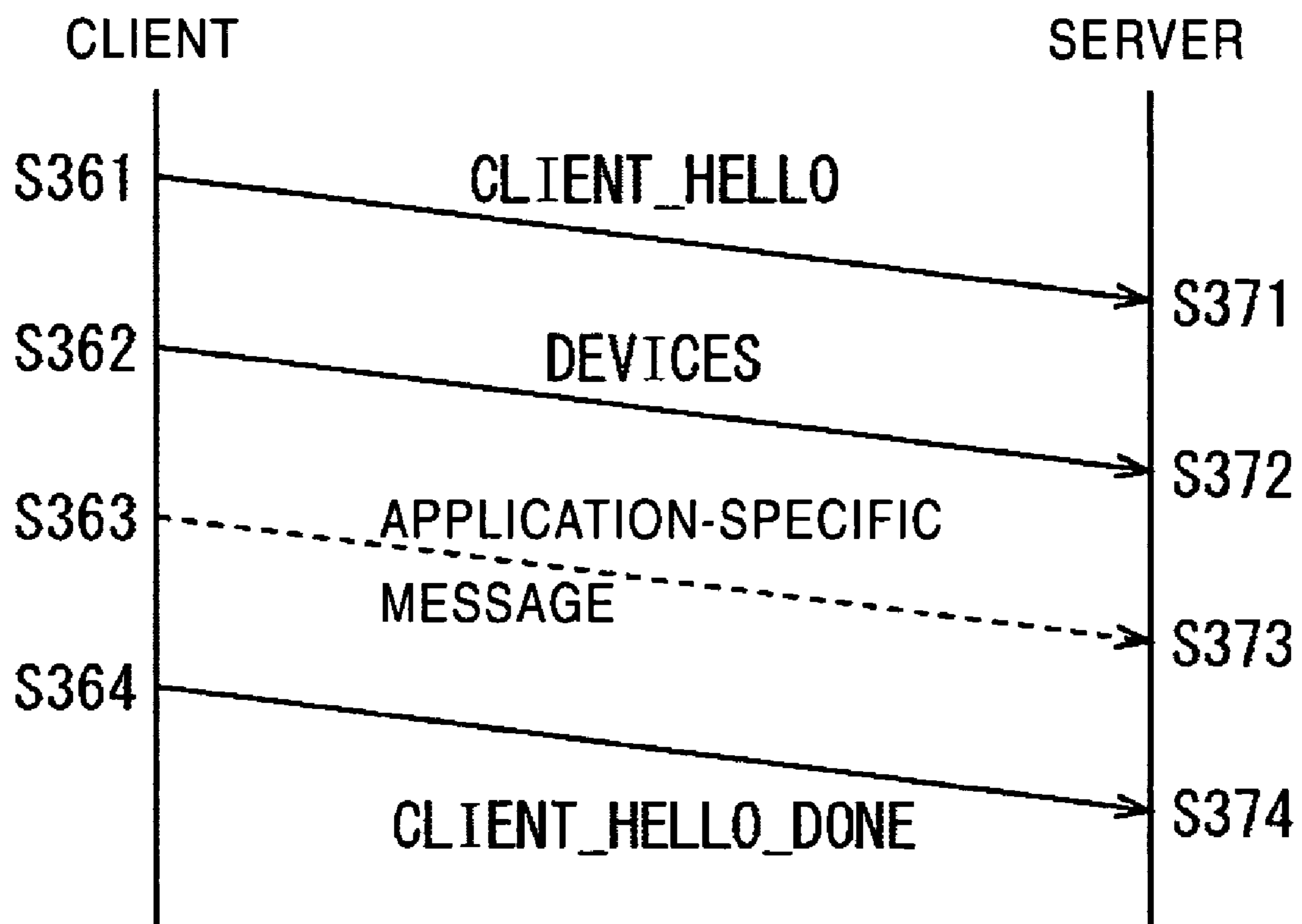
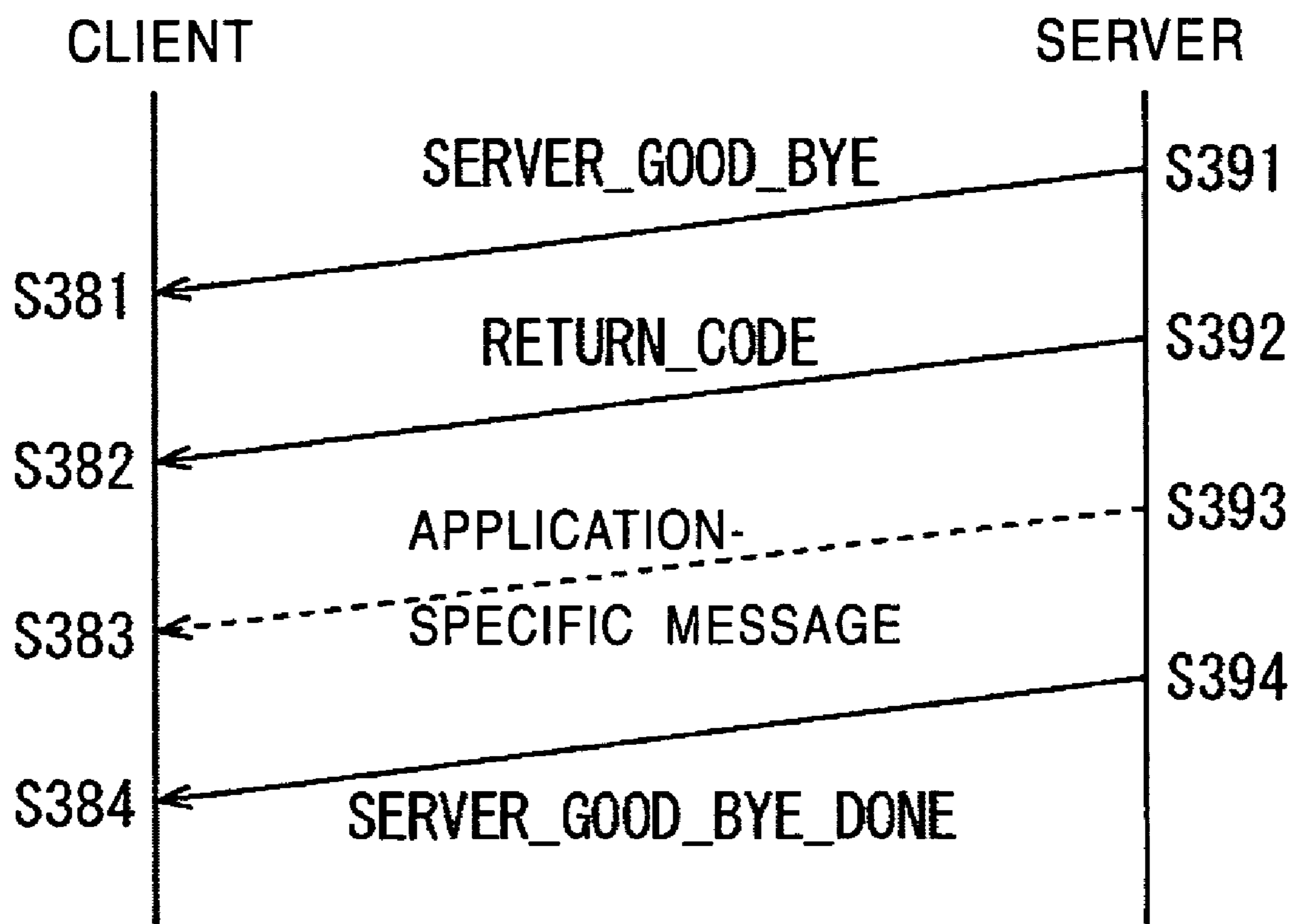

FIG. 27



**CONTROL SYSTEM AND CONTROL  
METHOD, METHOD AND APPARATUS FOR  
PROCESSING INFORMATION,  
INFORMATION PROCESSING TERMINAL  
AND METHOD THEREOF, STORAGE  
MEDIUM, AND PROGRAM**

BACKGROUND OF THE INVENTION

1. Field of the Invention

The present invention relates to a control system and a control method, an information processing method and an information processing apparatus, an information processing terminal and a method for an information processing terminal, a storage terminal, and a program. More particularly, the present invention relates to a control system and a control method, an information processing method and an information processing apparatus, an information processing terminal and a method for an information processing terminal, a storage terminal, and a program, for controlling a device connected via a network in a more reliable and more efficient manner.

2. Description of the Related Art

In recent years, various systems have been proposed for controlling a device installed at a remote location.

One of such systems is disclosed in Japanese Unexamined Patent Application Publication No. 2000-184081. In this system, home electric appliances installed in a home, such as an air conditioner or a video recorder, are controlled in accordance with passwords transmitted via a telephone from the outside of home.

Japanese Unexamined Patent Application Publication No. 2002-41378 discloses a system in which a server is disposed between a controlling terminal and a controlled terminal, and the controlling terminal controls the controlled terminal via the server.

In those control systems, a device to be controlled is required to be always connected to a control device via a communication means so that the control device disposed at a remote location can access the device to be controlled (for example, in the system disclosed in Japanese Unexamined Patent Application Publication No. 2000-184081, a home electric appliance is always connected to a telephone line via a remote controller and an adaptor).

That is, when a first device serving as a controlling device and a second device serving as a controlled device can communicate with each other whenever communication is needed, either device can start communication under the initiative of that device. For example, the first device can transmit various data including a request to the second device, and, conversely, the second device can transmit various data to the first device, whenever transmission is required.

This makes it possible to control the device by communicating with the device via a network, whenever the control is needed.

However, in a case in which a device such as a IC card, a display, or a memory is remotely controlled in an environment in which the device is not always connected to a network, the device is generally controlled in such a manner that a client such as a personal computer, which manages the device, transmits a request to a server, and the client controls the operation of the device in accordance with a response returned from the server. In this technique, however, it is difficult for the server to directly control the device under the initiative of the server.

That is, because the device is not always connected to the network, the server cannot access the client with an arbitrary timing to control the device managed by the client.

More specifically, it is very difficult for the server to take the initiative in changing a property of a device such as a IC card or a non-contact RF ID receiving) or controlling the operation of the device that is connected indirectly to the server with a particular timing when the device is placed near to or directly on an apparatus (such as a IC card reader/writer or a RF ID receiver) connected to a network.

Furthermore, in the conventional control system, when commands or responses are transmitted between a server and a client, one command or one response is transmitted at a time. This results in an increase in the number of times that transmission is performed between the server and the client, and thus results in an increase in communication cost.

Because information such as a header and a footer is added each time a command or a response is transmitted, the data size transmitted at a time increases and the communication time needed for each transmission increases. The above-described problem is serious in particular when a terminal such as a portable telephone, communication with which is low in communication speed and needs high cost, is remotely controlled.

Furthermore, in the conventional control system, when a client receives a command transmitted from a server, if an error occurs at the client, the process is terminated regardless of the type of the error. To make the client perform a following process, it is required that the server and the client be connected to each other and a command be retransmitted.

SUMMARY OF THE INVENTION

In view of the above, it is an object of the present invention to provide a technique of remotely controlling a device via a network in a highly reliable and efficient manner.

The present invention provides a control system comprising an information processing apparatus and an information terminal connected with each other via a network, wherein the information terminal includes request means for, in a state in which a device is connected with the information terminal, requesting the information processing apparatus to establish communication via the network, receiving means for receiving a packet including a command for controlling the device, from the information processing apparatus via communication established in response to the request issued by the request means, and control means for controlling the device in accordance with the command included in the packet received by the receiving means, and the information processing apparatus includes establishment means for establishing communication performed via the network between the information processing apparatus and the information terminal, in response to the request issued by the information terminal, and transmission means for transmitting the packet to the information terminal from the information processing apparatus after the communication with the information terminal is established by the establishment means.

The present invention provides a method for a control system, comprising the steps of, in a state in which a device is connected with an information terminal, requesting an information processing apparatus to establish communication via a network, receiving a packet including a command for controlling the device, from the information processing apparatus via communication established in response to the request issued in the request step, controlling the device in accordance with the command included in the packet received in the reception step, establishing communication performed

via the network between the information processing apparatus and the information terminal, in response to the request issued by the information terminal, and transmitting a packet to the information terminal from the information processing apparatus after the communication with the information terminal is established in the establishment step.

The present invention also provides an information processing apparatus comprising establishment means for establishing communication performed via a network between the information processing apparatus and an information terminal, in response to a request issued, in a state in which a device is connected with the information terminal, by the information terminal, and transmission means for transmitting a first packet including a command for controlling the device to the information terminal from the information processing apparatus after the communication with the information terminal is established by the establishment means.

The information processing apparatus may further comprise receiving means for receiving, from the information terminal, a second packet including a response to the command transmitted from the transmission means.

The command may include information indicating whether, when the information terminal fails to perform a process in accordance with the command, a process should be continued in accordance with a following command.

The first packet transmitted by the transmission means may include a plurality of commands belonging to the same protocol.

The transmission means may transmit, together with the first packet, a simple program for causing the information terminal to determine which process should be performed by the device.

The first packet transmitted by the transmission means may include identification information identifying the device to be controlled in accordance with the command.

When the communication link established by the establishment means includes a firewall of the information terminal, the transmission means may transmit the first packet using HTTP as a communication protocol.

The transmission means may maintain the communication link using HTTP established by the establishment means for a period during which a plurality of first packets are transmitted.

The information processing apparatus may further comprise command means for commanding the information terminal to start transmitting predetermined information in the communication established by the establishment means.

The present invention also provides an information processing method associated with an information processing apparatus, comprising the steps of establishing communication performed via a network between the information processing apparatus and an information terminal, in response to a request issued, in a state in which a device is connected with the information terminal, by the information terminal, and transmitting a packet including a command for controlling the device to the information terminal from the information processing apparatus after the communication with the information terminal is established in the establishment step.

The present invention also provides a first program and a storage medium including the first program stored thereon, wherein the program comprises the steps of establishing communication performed via a network between an information processing apparatus and an information terminal, in response to a request issued, in a state in which a device is connected with the information terminal, by the information terminal, and transmitting a packet including a command for controlling the device to the information terminal from the

information processing apparatus after the communication between the information terminal and the information processing apparatus is established in the establishment step.

The present invention also provides an information terminal comprising request means for, in a state in which a device is connected with the information terminal, requesting an information processing apparatus to establish communication via a network, receiving means for receiving a first packet including a command for controlling the device, from the information processing apparatus via communication established in response to the request issued by the request means, and control means for controlling the device in accordance with the command included in the first packet received by the receiving means.

The information terminal may further comprise transmission means for transmitting to the information processing apparatus a second packet including a response indicating a result of controlling performed by the control means on the device.

The present invention also provides an information processing method comprising the steps of in a state in which a device is connected with an information terminal, requesting the information processing apparatus to establish communication via a network, receiving a packet including a command for controlling the device, from the information processing apparatus via communication established in response to the request issued in the request step, and controlling the device in accordance with the command included in the packet received in the reception step.

The present invention also provides a second program and a storage medium including the second program stored thereon, wherein the second program includes the steps of in a state in which a device is connected with an information terminal, requesting an information processing apparatus to establish communication via a network, receiving a packet including a command for controlling the device, from the information processing apparatus via communication established in response to the request issued in the request step, and controlling the device in accordance with the command included in the packet received in the reception step.

In the control system and the method according to the present invention, in a state in which a device is connected with an information terminal, a request for establishing communication via a network is issued to an information processing apparatus, a packet including a command for controlling the device is transmitted from the information processing apparatus in communication established in response to the request and received by the information terminal, and the device is controlled in accordance with the command included in the received packet. After communication via the network between the information processing apparatus and the information terminal is established in response to the request issued by the information terminal, a packet is transmitted to the information terminal.

In the information processing apparatus, the information processing method, the storage medium, and the program according to the present invention, communication via a network between the information processing apparatus and an information terminal is established in response to a request issued by the information terminal in a state in which a device is connected to the information terminal. After the communication between the information processing apparatus and the information terminal is established, a first packet including a command for controlling the device is transmitted to the information terminal.

In the information processing terminal, the method for the information processing terminal, the storage medium, and the

5

program according to the present invention, in a state in which a device is connected with an information terminal, a request for establishing communication via a network is issued to an information processing apparatus. After the communication is established in response to the request, a packet including a command for controlling the device is received from the information processing apparatus via communication established, and the device is controlled in accordance with the command included in the received packet.

#### BRIEF DESCRIPTION OF THE DRAWINGS

FIG. 1 is a diagram showing an example of a control system according to the present invention;

FIG. 2 is a block diagram showing an example of a configuration of a server shown in FIG. 1;

FIG. 3 is a block diagram showing an example of a functional configuration of the server;

FIG. 4 is a block diagram showing an example of a functional configuration of a client;

FIG. 5 is a state transition diagram of control protocols;

FIG. 6 is a diagram showing an example of a data format of a packet;

FIG. 7 is a diagram showing messages used in a handshake protocol;

FIG. 8 is a diagram showing a handshake protocol executed using messages shown in FIG. 7;

FIG. 9 is a diagram showing messages used in a farewell protocol;

FIG. 10 is a diagram showing a farewell protocol executed using messages shown in FIG. 9;

FIG. 11 is a diagram showing messages used in an error protocol;

FIG. 12 is a diagram showing an error protocol executed using messages shown in FIG. 11;

FIG. 13 is a diagram showing another example of an error protocol executed using messages shown in FIG. 11;

FIG. 14 is a diagram showing messages used in an update entity protocol;

FIG. 15 is a diagram showing an update entity protocol executed using messages shown in FIG. 14;

FIG. 16 is a diagram showing messages used in an application data transfer protocol;

FIG. 17 is a diagram showing a sequence of an application data transfer protocol executed using messages shown in FIG. 16;

FIG. 18 is a diagram showing messages used in an operate entity protocol;

FIG. 19 is a diagram showing a sequence of an operate entity protocol executed using messages shown in FIG. 18;

FIG. 20 is a diagram showing a sequence of communication in a neutral state;

FIG. 21 is a diagram showing another example of sequence of communication in the neutral state;

FIG. 22 is a diagram showing still another example of sequence of communication in the neutral state;

FIG. 23 is a diagram showing a sequence of an exchange protocol;

FIG. 24 is a diagram showing a sequence of an exchange protocol;

FIG. 25 is a state transition diagram of control protocols;

FIG. 26 is a diagram showing another example of a sequence of a handshake protocol; and

6

FIG. 27 is a diagram showing another example of a sequence of a farewell protocol.

#### DESCRIPTION OF THE PREFERRED EMBODIMENTS

FIG. 1 shows an example of a control system according to the present invention.

Clients are connected to a network 1 (devices are connected to the network 1 via clients), and servers 2 and 4 for remotely controlling the clients are also connected to the network 1. The server 2 is also connected to a cryptography/authentication server 3 for performing encryption, decryption, and authentication of data in cooperation with the server 2.

Each of the server 2 and the server 4 controls devices via a client.

A portable telephone 5 and a personal computer 6 serving as clients are connected to the network 1. As will be described in detail later, a protocol is used which allows a server (the server 2 or the server 4) to control a client (the portable telephone 5 or the personal computer 6) under the initiative of the server via communication between the server and the client.

In the example shown in FIG. 1, a reader/writer 11, a IC card 13, a speaker 14, and a display 15, which are devices controlled by the server 2 or the server 4 via the client, are connected to the portable telephone 5 or disposed in the portable telephone 5.

An external IC card 12 is indirectly connected to the portable telephone 5 via a reader/writer 11. Unlike the IC card 13 that is directly connected to or disposed in the portable telephone 5, the external IC card 12 is indirectly connected to the portable telephone 5 via communication using electromagnetic induction when the external IC card 12 is placed near to or directly on the reader/writer 11.

Similarly, in FIG. 1, a IC card 21, a speaker 22, a display 23, and a reader/writer 24, which are devices controlled by the server 2 or the server 4 via the client, are connected to the personal computer 6. An external IC card 25 is placed near to or directly on the reader/writer 24 with an arbitrary timing.

Those devices (the reader/writer 11, the external IC card 12, the IC card 13, the speaker 14, the display 15, the IC card 21, the speaker 22, the display 23, the reader/writer 24, and the external IC card 25) are not always connected to the network 1 via clients but are connected with an arbitrary timing as required.

As a matter of course, the system configuration shown in FIG. 1 can be modified as required. For example, in addition to or instead of the portable telephone 5 or the personal computer 6, a PDA (Personal Digital Assistant) device as a client or a memory as a device may be connected to the server 2 or the server 4 via the network 1.

FIG. 2 is a block diagram showing an example of a configuration of the server 2 shown in FIG. 1.

A CPU (Central Processing Unit) 31 performs various processes in accordance with a program stored in a ROM (Read Only Memory) 32 or a program loaded into a RAM (Random Access Memory) 33 from a storage unit 38. The RAM 33 is also used to store data necessary in processes executed by the CPU 31.

For example, a server for controlling clients via communication using a protocol (hereinafter, referred to as a control protocol) in the communication system shown in FIG. 1 is realized by executing a particular control program on the CPU 31.

The CPU **31**, the ROM **32**, and the RAM **33** are connected to each other via a bus **34**. The bus **34** is also connected to an input/output interface **35**.

The input/output interface **35** is also connected to an input unit **36** including a keyboard, mouse, and the like, an output unit **37** including a display such as a CRT (Cathode Ray Tube) or a LCD (Liquid Crystal Display) and a speaker, a storage unit **38** such as a hard disk drive, and a communication unit **39** such as a modem or a terminal adapter. The communication unit **39** is responsible for communication via the network **1**.

A drive **40** is also connected to the input/output interface **35** as required, and a magnetic disk **41**, an optical disk **42**, a magneto-optical disk **43**, or a semiconductor memory **44** is mounted on the drive **40**, as required, to install a computer program therefrom into the storage unit **38**.

The server **4** and the portable telephone **5** and the personal computer **6** serving as clients have similar configurations to that of the server **2** described above with reference to FIG. **2**, and thus a duplicated description of the configurations of those server and clients is not given herein. In the following description, FIG. **2** is also referred to when the portable telephone **5** or the personal computer **6** is discussed.

The protocol used in communication between a server and a client is described below. Hereinafter, the protocol used in communication between a server and a client is referred to as a control protocol.

In the background of a Web application executed on a client, communication between the client and a server is performed using the control protocol. In the portable telephone **5** or a similar apparatus serving as a client, the Web application is not necessary, only communication between the client and the server is performed. In this case, for example, an application of the portable telephone **5** retains all data to be displayed, and the data is displayed by controlling the application and the display in a similar manner to that in which the device is controlled.

A Web application using control protocols may be developed. In such a Web application, for example, a business logic may be described in a single function/method. This provides the following advantages. Firstly, the application can be executed without concern for disconnection of HTTP (Hyper Text Transfer Protocol). Secondly, a server is allowed to transmit a request to a client (that is, a requester of HTTP is not limited to a client). Thirdly, an arbitrary process is allowed to be performed on a client (there is no limitation similar to that in Applet or ActiveX control).

The control protocol includes a data transfer protocol and other subprotocols. For example, subprotocols include a handshake protocol, a farewell protocol, an error protocol, an update entity protocol, an application data transfer protocol, and an operate entity protocol.

More particularly, the data transfer protocol defines a transmission/reception procedure of a subprotocol message, and the handshake protocol defines a procedure of establishing a connection. The farewell protocol defines a procedure of releasing a connection, and the error protocol defines an error notification procedure.

The update entity protocol defines a procedure performed by a server to change the state of a client. The application data transfer protocol defines a transmission/reception procedure of data specific to an application. The operate entity protocol defines a procedure performed by a server to operate a client.

The control protocol including those protocols described above defines only a core (frame) of data communication. To perform a process specific to an application, such as an operation of a particular device, an extension (extension module)

for the application is needed. That is, a combination of a main control protocol and an extension defines an operation procedure.

FIG. **3** is a block diagram showing an example of a functional configuration of a server (for example, the server **2**) performing communication according to a control protocol. Each functional block shown in FIG. **3** is realized by executing a particular control program on a CPU **31** of the server **2**.

A controller **51** controls the entire server **2** including a handshake message manager **52** for managing messages included in a handshake protocol, a farewell message manager **55** for managing messages included in a farewell protocol, an error message manager **58** for managing messages included in an error protocol, an application-data-transfer message manager **61** for managing messages included in an application data transfer protocol, an update-entity message manager **64** for managing messages included in an update entity protocol, and an operate-entity message manager **67** for managing messages included in an operate entity protocol.

The messages included in the handshake protocol (hereinafter referred to as handshake messages) will be described in detail later with reference to FIG. **7**. The messages included in the farewell protocol (hereinafter referred to as farewell messages) will be described in detail later with reference to FIG. **9**. The messages included in the error protocol (hereinafter referred to as error messages) will be described in detail later with reference to FIG. **11**. The messages included in the update entity protocol (hereinafter referred to as update entity messages) will be described in detail later with reference to FIG. **14**. The messages included in the application data transfer protocol (hereinafter referred to as application data transfer messages) will be described in detail later with reference to FIG. **16**. The messages included in the operate entity protocol (hereinafter referred to as operate-entity messages) will be described in detail later with reference to FIG. **18**.

The handshake message manager **52** manages processes associated with handshake messages. For example, if a handshake message included in a packet transmitted from a client is received by a handshake message reception controller **54** and transferred to the handshake message manager **52**, the handshake message manager **52** produces a handshake message corresponding to the received message and supplies the produced handshake message, to be transmitted to the client, to a handshake message transmission controller **53**.

The handshake message transmission controller **53** controls transmission, performed by the communication unit **39** shown in FIG. **2**, of handshake messages to clients such as the portable telephone **5**. The handshake message reception controller **54** controls reception, performed by the communication unit **39** shown in FIG. **2**, of handshake messages from clients.

The farewell message manager **55** controls processes associated with farewell messages. For example, if a farewell message included in a packet transmitted from a client is received by a farewell message reception controller **57** and transferred to the farewell message manager **55**, the farewell message manager **55** produces a farewell message in response to the received message, and supplies the produced farewell message, to be transmitted to the client, to a farewell message transmission controller **56**.

The farewell message transmission controller **56** controls transmission, performed by the communication unit **39** shown in FIG. **2**, of farewell messages to clients. The farewell message reception controller **57** controls reception, performed by the communication unit **39** shown in FIG. **2**, of farewell messages from clients.

The error message manager **58** controls processes associated with error messages. For example, if the controller **51** detects that a format error is included in a packet received from a client, the error message manager **58** produces an error message depending on the detected error and supplies the produced error message, to be transmitted to the client, to an error message transmission controller **59**.

The error message transmission controller **59** controls transmission, performed by the communication unit **39** shown in FIG. 2, of error messages to clients. An error message reception controller **60** controls reception, performed by the communication unit **39** shown in FIG. 2, of error messages from clients.

The application-data-transfer message manager **61** manages application-data-transfer messages. For example, if an application-data-transfer message included in a packet transmitted from a client is received by an application-data-transfer message reception controller **63** and transferred to the application-data-transfer message manager **61**, the application-data-transfer message manager **61** produces an application-data-transfer message in response to the received message and supplies the produced application-data-transfer message, to be transmitted to the client, to an application-data-transfer message transmission controller **62**.

The application-data-transfer message transmission controller **62** controls transmission, performed by the communication unit **39** shown in FIG. 2, of application-data-transfer messages to clients. More particularly, the application-data-transfer message transmission controller **62** adds a finished message to a set of a particular number of messages supplied from the application-data-transfer message manager **61** and transmits them in the form of a packet to a client.

The application-data-transfer message reception controller **63** controls reception, performed by the communication unit **39** shown in FIG. 2, of application-data-transfer messages from clients. More particularly, the application-data-transfer message reception controller **63** detects the end of a packet received from a client by detecting a finished message included in the packet, the application-data-transfer message reception controller **63** outputs an application-data-transfer message included in the packet to the application-data-transfer message manager **61**.

The update-entity message manager **64** manages processes associated with update-entity messages. For example, if the update-entity message manager **64** is commanded by the controller **51** to transmit a particular update-entity message to a client, the update-entity message manager **64** produces an update entity message according to the command and supplies the produced update entity message, to be transmitted to the client, to an update-entity message transmission controller **65**.

The update-entity message transmission controller **65** controls transmission, performed by the communication unit **39** shown in FIG. 2, of update entity messages to clients. More particularly, the update-entity message transmission controller **65** adds a finished message to a set of a particular number of messages supplied from the update-entity message manager **64** and transmits them in the form of a packet to a client.

An update entity message reception controller **66** controls reception, performed by the communication unit **39** shown in FIG. 2, of update entity message from clients. More particularly, the update entity message reception controller **66** detects the end of a packet received from a client by detecting a finished message included in the packet, and the update entity message reception controller **66** outputs an update entity message included in the packet to the update-entity message manager **64**.

The operate-entity message manager **67** manages processes associated with operate-entity messages. For example, if the operate-entity message manager **67** is commanded by the controller **51** to transmit a particular operate-entity message to a client, the operate-entity message manager **67** produces an operate-entity message according to the command and supplies the produced operate-entity message, to be transmitted to the client, to an operate-entity message transmission controller **68**.

The operate-entity message transmission controller **68** controls transmission, performed by the communication unit **39** shown in FIG. 2, of operate-entity messages to clients. More particularly, the operate-entity message transmission controller **68** adds a finished message to a set of a particular number of messages supplied from the operate-entity message manager **67** and transmits them in the form of a packet to a client.

An operate-entity message reception controller **69** controls reception, performed by the communication unit **39** shown in FIG. 2, of operate-entity messages from clients. More particularly, the operate-entity message reception controller **69** detects the end of a packet received from a client by detecting a finished message included in the packet, and the operate-entity message reception controller **69** outputs an operate-entity message included in the packet to the operate-entity message manager **67**.

FIG. 4 is a block diagram showing an example of a functional configuration of a client (for example, the portable telephone **5**) performing communication according to a control protocol. The functional configuration shown in FIG. 4 is similar to the functional configuration of the server described above with reference to FIG. 3, and thus a duplicated description thereof is not given herein.

Each functional block shown in FIG. 4 is realized by executing a particular control program on a CPU **31** of the portable telephone **5**.

A controller **81** controls the entire portable telephone (client) including a handshake message manager **82**, a farewell message manager **85**, an error message manager **88**, an application-data-transfer message manager **91**, an update-entity message manager **94** and an operate-entity message manager **97**.

For example, when an update-entity message transmitted from a server is received by the update entity message reception controller **96** and transferred to the controller **81** via the update-entity message manager **94**, the controller **81** commands a device controller **100** to control a device to perform a process according to the received update-entity message.

After completion of the process performed by the device connected to the client, the controller **81** acquires information indicating the result of the process (for example, information indicating whether the process is successfully completed) from the device controller **100** and supplies the acquired information to the update-entity message manager **94**.

The update-entity message manager **94** produces a response message (update-entity message) on the basis of the results of the process and transmits the produced response message to the server via the update-entity message transmission controller **95**.

The device controller **100** controls the operation of a device connected to the client in accordance with a command that may be issued in one of the following situations. Firstly, when an application-data-transfer message acquired by the application-data-transfer message reception controller **93** is transferred to the controller **81**, a command for causing a device to perform a process according to the application-data-transfer message is issued by the controller **81**. Secondary, when an

## 11

update-entity message acquired by the update entity message reception controller 96 is transferred to the controller 81, a command for causing a device to perform a process according to the update-entity message is issued by the controller 81. Thirdly, when an operate-entity message acquired by the operate-entity message reception controller 99 is transferred to the controller 81, a command for causing a device to perform a process according to the operate-entity message is issued by the controller 81.

The device controller 100 supplies information indicating the result of the control (the result of the process performed by the device) to the controller 81. On the basis of the result of the process, a response to be sent to the server is produced by the application-data-transfer message manager 91, the update-entity message manager 94, or the operate-entity message manager 97.

Now, referring to FIG. 5, state transitions of control protocols are described below. The details of communication performed in respective state will be described later.

In step S1, the CPU 31 of a client (for example, the portable telephone 5) starts to execute a client program. As a result, state transitions start. When the client program is started, the following information is necessary.

Server URL (Uniform Resource Locator): URL of a server that controls the client.

URL of a viewer Web application: URL of a Web application that provides a viewer on a screen of an application executed at an end user.

This URL is not necessary when the client (for example, the portable telephone 5) does not need the Web application.

Cookie (optional): Cookie for identifying a session

A client transmits a HTTP request using a specified session ID to a server (for example, the server 2) specified by a server URL. In the example described above, a HTTP request for posting a message at a server is transmitted to a particular port number of the URL.

In a case in which cookie information is set when the client program is started, the client adds specified cookie information to a cookie header of the HTTP request.

A response message returned from a server is described in a content part of a HTTP response.

After starting the client program, in step S2, the client transmits a client-hello message using a handshake subprotocol to request establishment of communication.

That is, in a handshake state (state 1 in FIG. 5), a client-hello message is transmitted and a connection is established.

After completion of the handshake protocol, in step S3, the client transmits a finished message to the server. In response, the connection is established, and the initiative of the control is transferred to the server.

In some cases, connection is established in response to transmitting a client-hello-done message from a client to a server (FIG. 25).

That is, a particular command (message) is transmitted from the server to the client, and a response indicating the result of the process performed in accordance with the command is returned from the client to the server. After the connection is established and the initiative is transferred to the server, the state changes into a neutral state (state 2 in FIG. 5).

In step S4, in the neutral state, the server controls the state of the client or transmits/receives data specific to the application in accordance with the logic of the application.

In this process, the control of the state of the client is performed using an update-entity subprotocol. On the other hand, an application-data-transfer subprotocol is used to

## 12

transmit/receive data specific to the application, and an operate-entity subprotocol is used to operate the device connected to the client.

Only in the neutral state, an arbitrary combination of the above three subprotocol protocols is allowed to be transmitted/received at a time in an arbitrary order. For example, as will be described later with reference to FIGS. 20 to 22, one packet can include only one type of subprotocol (that is, one packet includes a header and a message sequence of one type of subprotocol). At the end of the packet, a finished message of the subprotocol is placed.

In each message transmitted from the server to the client using a subprotocol (update entity subprotocol, application data transfer subprotocol, or operate entity subprotocol) in the neutral state, there is included information indicating whether, if the process is failed, the following process should be continued.

For example, when the client fails to process a message whose starting bit is "0", following messages are not processed. On the other hand, when the client fails to process a message whose starting bit is "1", following messages are processed. This also applies to other subprotocol extension messages.

If the logic of the application is completed, then, in step S5, the server transmits a server-good-bye message to the client using a farewell subprotocol. The state after the transmission of the server-good-bye message and before the releasing of connection is referred to as a farewell state (state 3 in FIG. 5).

If the server determines that the farewell protocol is completed, then, in step S6, the server transmits a finished message to the client and ends the connection. In response, in step S7, the client releases the resource and ends the process.

In some cases, the connection is ended when the server transmits a server-good-bye-done message to the client not via the farewell state. In response, the client releases the resource and ends the process (FIG. 25).

When an error occurs at an arbitrary step (state) and it becomes impossible to continue the following process, the client of the server jumps to step SB and transmits an error message using an error subprotocol to the server or the client. The state from the occurrence of an error to the end of communication using a control protocol is referred to as an error state (state 4 in FIG. 5).

In step S9, for example, when a finished message is transmitted from the message to the client, the error state is ended, and the connection is closed.

As described above, communication between a client and a server is performed using a control protocol whose state changes in the above-described manner.

Now, the data format of packets defined by the data transfer protocol is described below.

FIG. 6 shows an example of a data format of a packet.

As shown in FIG. 6, a packet includes a header and a sequence of a predetermined number of messages (subprotocol messages).

The header includes three fields: a version field, a subprotocol type (SPT) field, and a length field.

The version number of the control protocol is described in the version field. More specifically, a major version number is represented by high-order bytes of the version and a minor version number is represented by low-order bytes. If the data transfer protocol is changed, the major version number is increased, and the minor version number is increased when a subprotocol is added or changed.

The subprotocol type indicates the type of a subprotocol used in a packet, wherein the type may be one of handshake



## 13

protocol, farewell protocol, error protocol, application data transfer protocol, update-entity protocol, and operate entity protocol.

The length indicates the length of the message sequence.

Each message included in the message sequence consists of an extension (Ext) field, a device ID (DID) field, a message type (MT) field, a length field, and a data field.

In the extension field, the type of an extension for a process specific to the application domain is described.

In the device ID field, the ID of a device to be controlled according to the message is described. For example, in a case in which a plurality of devices are connected to a client, the ID may be set so as to generically indicate all those devices to be controlled according to the message, or the ID may be set such that the server and the client can deal with the message without concern for a specific device.

In the message type field, the type of the message is described. As will be described later, the handshake protocol may include a client-hello message transmitted from a client to a server or a server-hello message transmitted from a server to a client, and the type of such a message is indicated by the message type.

In the length field, the length of data in the data part of the message is described. The data format of the data part of the message depends on the message type.

The subprotocols are described in further detail below.

FIG. 7 shows messages transmitted using a handshake protocol.

As shown in FIG. 7, a finished message indicates the end of a subprotocol, and a warning message indicates a warning. The data part of the warning message includes a warning represented by a particular character string.

A client-hello message indicates the start of transmission of handshake data from a client to a server, and a client-hello-done message indicates the end of the handshake data.

A server-hello message indicates the start of handshake data from a server to a client, and a server-hello-done message indicates the end of the handshake data.

A devices message is a notification of a device list. In the data part of the devices message, device IDs uniquely assigned to respective devices, permission, type name lengths, type names, device name lengths, and device names are described. The permission indicates whether or not access to a device is permitted. When the permission is set to "0", access to the device (operation of the device) is permitted. However, access (operation) is not permitted when the permission is set to "1".

The devices message is used, for example, to inform a server of what devices are connected to the client and can be remotely operated and what processes devices can perform in response to given commands.

Referring to a sequence flow shown in FIG. 8, the handshake protocol, in which messages shown in FIG. 7 are transmitted, is described below. In this sequence, by way of example, processes are performed by the portable telephone 5 acting as a client and the server 2 acting as a server for controlling a device via communication using control protocols.

In step S21, the sequence of the handshake protocol starts when, for example, the handshake message transmission controller 83 (FIG. 4) of the portable telephone 5 (client) transmits a client-hello message to, for example, the server 2. More specifically, in response to a command issued by the controller 81, the handshake message manager 82 produces a client-hello message and transmits it to the server 2 via the handshake message transmission controller 83.

## 14

In step S22, the handshake message transmission controller 83 of the portable telephone 5 transmits a devices message to the server 2 to provide information associated with all devices that are connected to the portable telephone 5 and that can be controlled by the server 2. Also this devices message is produced by the handshake message manager 82 under the control of the controller 81.

For example, information about the reader/writer 11 connected to the portable telephone 5 and the external IC card 12 connected via the reader/writer 11 to the portable telephone 5 is provided to the server 2 using the devices message.

In step S23, a message specific to the application is transmitted. Thereafter, when a client-hello-done message is transmitted in step S24, the transmission of the handshake data from the portable telephone 5 to the server 2 is completed.

If the handshake message reception controller 54 of the server 2 acquires, in steps S41 to S44, the client-hello message, the devices message, the message specific to the application, and the client-hello-done message, transmitted from the portable telephone 5, then, in step S45, the handshake message transmission controller 53 (FIG. 3) transmits a server-hello message to the portable telephone 5.

In the next step S46, the handshake message transmission controller 53 of the server 2 transmits a message specific to the application. Thereafter, in step S47, the handshake message transmission controller 53 transmits a server-hello-done message. In the above steps, all messages including the message specific to the application are transmitted in the handshake protocol under the control of the handshake message transmission controller 53.

The server-hello message, the application-specific message, and server-hello-done message, transmitted from the sever 2, are received by the handshake message reception controller 84 of the portable telephone 5, in respective steps S25 to S27.

If both the portable telephone 5 and the server 2 have transmitted hello-done messages (the client-hello-done message and the server-hello-done message), then, in step S48, the handshake message transmission controller 53 of the server 2 transmits a finished message to the portable telephone 5.

The finished message transmitted from the server 2 is received, in step S28, by the handshake message reception controller 84 of the portable telephone 5.

In step S29, the handshake message transmission controller 83 of the portable telephone 5 transmits a message specific to the application. In the next step S30, the handshake message transmission controller 83 of the portable telephone 5 transmits a finished message to the server 2. The message specific to the application and the finished message transmitted from the portable telephone 5 are received in steps S49 and S50, respectively, by the handshake message reception controller 54 of the server 2. At this point of time, the handshake protocol is completed at both the portable telephone 5 and the server 2.

In FIG. 8, dotted lines indicate that messages specific to the application are transmitted only when they are necessary. Note that as many messages specific to the application as necessary are transmitted. For example, in step S23, no message is transmitted in some cases, but a plurality of messages are transmitted in some cases. This is also true in a sequence described later with reference to FIG. 10.

Although in FIG. 8, the handshake protocol is completed when the finished message is received in step S50 by the server 2, the handshake protocol may be completed when the client-hello-done message is received in step S44 by the server 2.

## 15

Furthermore, although in FIG. 8, the hello messages and the hello-done messages are transmitted by both the server 2 and the portable telephone 5, those messages may be transmitted only from the portable telephone 5 to the server 2. This makes it possible to quickly end the handshake protocol and start a process in the neutral state, although a slight reduction occurs in the reliability of the handshake protocol. In other words, if both the portable telephone 5 and the server 2 transmit/receive the hello messages and the hello-DONE messages, the handshake protocol is executed in a more reliable fashion.

FIG. 9 shows messages used in a farewell protocol.

A finished message indicates the end of a subprotocol, and a warning message indicates a warning. The data part of the warning message includes a warning message represented by a particular character string.

A client-good-bye message indicates the start of transmission of farewell data from a client to a server, and a client-good-bye-done message indicates the end of the farewell data.

A server-good-bye message indicates the start of farewell data from a server to a client, and a server-goodbye-done message indicates the end of the farewell data.

A return-code message is a notification of the end of code from the server, wherein its data part includes an end code.

Referring to a sequence flow shown in FIG. 10, the farewell protocol, in which messages shown in FIG. 9 are transmitted, is described below.

The farewell protocol starts when the farewell message transmission controller 56 of the server 2 transmits a server-good-bye message in step S81. That is, the farewell protocol starts when the server 2 having the initiative in communication transmits a message (the server 2 has the initiative in communication after the handshake protocol is completed, as described earlier with reference to FIG. 5).

In step S82, the farewell message transmission controller 56 of the server 2 transmits a return-code message to the portable telephone 5 (client). In the next step S83, a message specific to the application (a farewell extension message specified in the extension field) is transmitted.

After completion of transmitting all messages specific to the applications, the process proceeds to step S84. In step S84, the farewell message transmission controller 56 of the server 2 transmits a server-good-bye-done message to the portable telephone 5.

Each information transmitted from the server 2 in steps S81 and S84 is received in steps S61 to S64 by the farewell message reception controller 87 of the portable telephone 5.

In step S65, the farewell message transmission controller 86 of the portable telephone 5 transmits a client-good-bye message to the server 2.

In the next step S66, the farewell message transmission controller 86 of the portable telephone 5 transmits a message specific to the application. Thereafter, in step S67, the farewell message transmission controller 86 of the portable telephone 5 transmits a client-good-bye-done message.

After completion of transmitting the client-good-bye-done message, the farewell message transmission controller 86 of the portable telephone 5, the farewell message transmission controller 86 transmits a finished message in step S68. Each information transmitted in steps S65 to S68 from the farewell message transmission controller 86 of the portable telephone 5 is received in steps S85 to S88 by the farewell message reception controller 57 of the server 2.

If the finished message transmitted by the portable telephone 5 is received in step S88 by the farewell message reception controller 57 of the server 2, the process proceeds to

## 16

step S89. In step S89, the farewell message transmission controller 56 transmits a finished message to the portable telephone 5 and ends the farewell protocol. The finished message transmitted from the farewell message transmission controller 56 of the server 2 is received in step S69 by the portable telephone 5.

Alternatively, the farewell protocol may be ended when the server-good-bye-done message is transmitted in step S84. This makes it possible to quickly end the farewell protocol.

FIG. 11 shows messages used in an error protocol.

A finished message indicates the end of a subprotocol, and a warning message indicates a warning. The data part of the warning message includes a warning message represented by a particular character string.

A packet-format-error message indicates that a packet includes a format error. An illegal-state-error message indicates that an illegal message has been detected.

An unexpected-error message indicates that an unexpected error has occurred.

The data part of each of the packet-format-error message, the illegal-state-error message, and the unexpected-error message includes an error message indicating the content of the error represented by a particular character string.

Referring to FIG. 12 and a sequence flow shown in FIG. 13, the error protocol, in which messages shown in FIG. 11 are transmitted, is described.

FIG. 12 shows a sequence of the error protocol executed when the portable telephone 5 detects an error.

If the controller 81 of the portable telephone 5 detects an error that makes it impossible to further continue the process, the controller 81 commands, in step S101, the error message manager 88 to transmit one of messages shown in FIG. 11 (a packet-format-error message, an illegal-state-error message, or an unexpected-error message) to inform the server 2 of the occurrence of the error (and the content of the detected error). More specifically, under the control of the controller 81, the error message manager 88 produces a particular message and transmits it via the error message transmission controller 89.

Thereafter, a finished message is transmitted in step S102 from the portable telephone 5 and received in step S112 by the server 2, and a finished message is transmitted in step S113 from the server 113 and received in step S103 by the portable telephone 5, thereby the communication between the server and the client is ended, as described earlier with reference to FIG. 5.

FIG. 13 shows an error protocol executed when the server 2 detects an error.

If the controller 51 of the server 2 detects an error that makes it impossible to further continue the process, the controller 51 commands, in step S131, the error message manager 58 to transmit a message depending on the content of the detected error to the portable telephone 5 to inform the occurrence of the error. More specifically, under the control of the controller 51, the error message manager 58 produces a particular message and transmits it via the error message transmission controller 59.

In step S132, after transmitting the message indicating the occurrence of the error, the error message transmission controller 59 of the server 2 transmits a finished message to the portable telephone 5.

The messages transmitted from the server 2 are received in steps S121 and S122 by the portable telephone 5, and the communication is ended.

As described above, each of the server 2 and the portable telephone 5 can transmit, with an arbitrary timing, an error message to the other apparatus when an error is detected.

Instead of transmitting a message using the error subprotocol, an error message defined in the application may be transmitted to notify the occurrence of an error.

Of the error messages, a warning message does not influence the sequence. When either one of the server **2** and the portable telephone **5** receives a warning message, the content of the message may be written in a log or may be ignored.

FIG. **14** shows messages transmitted in the update entity protocol.

Those messages transmitted in the update entity protocol are used to change the state (property) of devices. For example, those messages are used to turn on a LED (Light Emitting Diode) disposed on the surface of the reader/writer **11** shown in FIG. **1** or turn-on the power of a particular device.

A finished message indicates the end of a protocol, and a warning message indicates a warning. The data part of the warning message includes a warning message represented by a particular character string.

A set-property message is transmitted from a server to a client to set a property of a device connected to the client.

A property-set message is a message returned from the client as a response to the set-property message.

This set-property message is one of messages whose failure will make it impossible to further continue the process. Therefore, the first bit of the set-property message is set so as to indicate that the process should be terminated if a failure occurs.

The data part of the set-property message includes information associated with a property to be set to a device, such as a property name length, property name, property value length, and property value.

The data part of the property-set message returned from the client as a response to the set-property message transmitted from the server includes a flag indicating whether or not the process specified by the set-property message has been successfully performed by the client.

A get-property message is transmitted from a server to a client to acquire the property value of a device connected to the client. A get-property message is a message returned from the client as a response to the property message.

This get-property message is one of messages whose failure will make it impossible to further continue the process. Therefore, the first bit of the get-property message is set so as to indicate that the process should be terminated if a failure occurs.

The data part of the get-property message includes information indicating the property name length, the property name, and the like of a device whose property value is to be acquired.

A property message is a message returned from the client as a response to the get-property message transmitted from the server. The data part of the property message includes information indicating the property name length, the property name, and the like, requested by the server, of a device.

A set-network-timeout message indicates-a network time out to be set at the client.

This set-network-timeout message is one of messages whose failure at the client will not cause the process to be terminated. Therefore, the first bit of the set-network-timeout message is set so as to indicate that the process should be continues if a failure occurs.

The data part of the set-network-timeout message includes a time out value to be set at the client.

Referring to a sequence flow shown in FIG. **15**, the update entity protocol, in which messages shown in FIG. **14** are transmitted, is described below.

When the server **2** wants to change the state of a device connected to the portable telephone **5**, the update-entity message manager **64** of the server **2** produces, in step **S151**, an update-entity message to be transmitted to the portable telephone **5**, under the control of the controller **51**. The produced update-entity message is supplied to the update-entity message transmission controller **65**.

In step **S152**, the update-entity message transmission controller **65** of the server **2** adds a finished message at the end of the sequence of update-entity messages produced in step **S151** and transmits a packet including the sequence of update-entity messages and the finished message to the portable telephone **5**.

That is, the packet including a particular number of update-entity messages produced in step **S151** and the finished message added in step **S152** is transmitted to the portable telephone **5**.

Because a plurality of messages combined together with in one packet can be transmitted at a time to the portable telephone **5** (in this case, one header and one footer are needed to be added each time a plurality of messages are transmitted) the data size can be reduced compared with the case in which only one message is put together with a header and a footer in one packet and messages are transmitted on a message-by-message basis. This also allows reductions in the communication time and communication cost. This is also true for all protocols.

The update-entity messages included in the packet and transmitted from the server **2** are received in step **S141** by the update entity message reception controller **96** of the portable telephone **5**, and the finished message added at the end of the sequence of the update-entity messages is received in step **S142**.

In the portable telephone **5**, when the messages included in the packet transmitted from the server are acquired, the messages are processed in the same order as the order in which the messages are acquired. As required, a response indicating the result of the process is produced by the controller **81**.

The update entity message reception controller **96** of the portable telephone **5** detects the end of the packet by detecting the finished message transmitted from the server **2**. In step **S143**, the update-entity message manager **94** produces responses (update-entity messages) to the received update-entity messages.

For example, if an update-entity message received from the server **2** indicates that a property value of a device should be changed, the device controller **100** changes the property value in accordance with the update-entity message, and the controller **81** informs the update-entity message manager **94** whether or not the property value has been successfully changed. On the bases of the notification, the update-entity message manager **94** produces a response and supplies the produced response to the update-entity message transmission controller **65**.

In step **S144**, the update-entity message transmission controller **95** of the portable telephone **5** adds a finished message to the produced response and transmits a packet including the response and the finished message to the server **2**. Whether or not responses are returned and how many responses are returned depend on messages received from the server **2**.

In step **S153**, the packet including the sequence of update-entity messages transmitted from the portable telephone **5** is acquired by the update entity message reception controller **66** of the server **2**, and the finished message added at the end of the sequence of the update-entity messages is acquired in step **S154**.

Hereinafter, packets transmitted in the neutral state from the server **2** to the portable telephone **5** are referred to as control packets (specific examples of control packets are a packet including no or one or more update-entity messages and a finished message, a packet including no or one or more application-data-transfer messages and a finished message, and a packet including no or one or more operate-entity messages and a finished message).

Packets returned from the portable telephone **5** to the server **2** to inform of the result of a process performed in accordance with messages included in control packets are referred to as response packets (wherein each response packet includes no or one or more responses and a finished message).

As described above, a control packet including update-entity messages and a finished message is transmitted from the server **2** to the portable telephone **5** via communication performed under the initiative of the server **2**, and a process is performed by the portable telephone **5** in accordance with the update-entity messages. In the portable telephone **5**, furthermore, responses to the update-entity messages received from the server **2** are produced, and a response packets including the responses and a finished message is returned to the server **2**.

More specifically, if a control packet including a set-property message shown in FIG. **14** is transmitted from the server **2** to the portable telephone **5**, then, in the portable telephone **5**, a property value of a device is set in accordance with the set-property message, and a response packet including a property-set message (response) is returned to the server **2**.

The sequence of update-entity messages transmitted from the portable telephone **5** or the server **2** may include a particular number of application-specific messages (update-entity extension message specified in the extension field).

FIG. **16** shows messages used in the application data transfer protocol.

The application data transfer protocol is used, for example, when application data or an application command to control the external IC card **12** connected via the reader/writer **11** to the portable telephone **5** is transmitted between a server and a client (device).

A finished message indicates the end of a protocol, and a warning message indicates a warning. The data part of the warning message includes a warning message represented by a particular character string.

Referring to a sequence flow shown in FIG. **17**, the application data transfer protocol, in which messages shown in FIG. **16** are transmitted, is described below.

In step **S171**, the application-data-transfer message manager **61** of the server **2** produces a set of application-data-transfer messages.

The produced application-data-transfer messages are supplied to the application-data-transfer message transmission controller **62**.

In step **S172**, the application-data-transfer message transmission controller **62** of the server **2** adds a finished message at the end of the sequence of application-data-transfer messages produced, and transmits a control packet including the sequence of application-data-transfer messages and the finished message to the portable telephone **5**.

The application-data-transfer messages included in the control packet are received in step **S161** by the application-data-transfer message reception controller **93** of the portable telephone **5**, and the finished message is received in step **S162**.

The application-data-transfer message reception controller **93** of the portable telephone **5** detects the end of the control packet received from the server **2** by detecting the finished

message, and application-data-transfer message reception controller **93** of the portable telephone **5** supplies application-data-transfer messages included in the control packet to the application-data-transfer message manager **91**.

In step **S163**, responses to application-data-transfer message included in the packet are produced. More specifically, information indicating the result of the process performed by the device controller **100** is provided to the application-data-transfer message manager **91**, and the application-data-transfer message manager **91** produces responses depending on the result of the process. The produced responses are supplied to the application-data-transfer message transmission controller **92**.

In step **S164**, the application-data-transfer message transmission controller **92** of the portable telephone **5** adds a finished message at the end of the sequence of the produced responses (application-data-transfer messages), and transmits a response packet including the sequence of the responses and the finished message to the server **2**.

The application-data-transfer messages included in the packet transmitted from the portable telephone **5** are acquired in step **S173** by the application-data-transfer message reception controller **63** of the server **2**, and the finished message added at the end of the sequence of application-data-transfer messages is acquired in step **S174**.

Whether or not responses are returned and how many responses are returned depend on messages received from the server **2**.

As in the case of the update entity protocol described above, the sequence of application-data-transfer messages transmitted from the portable telephone **5** or the server **2** may include a particular number of application-specific messages (application-data-transfer extension message specified in the extension field).

FIG. **18** shows messages used in the operate entity protocol.

The operate entity protocol is used to control a device connected to a client. For example, starting or stopping of radiation of a radio wave from the reader/writer **11** connected to the portable telephone **5**, or displaying of a particular screen for use by a user to input a command/data is controlled using the operate entity protocol.

A finished message indicates the end of a protocol, and a warning message indicates a warning. The data part of the warning message includes a warning message represented by a particular character string.

An update-view message is transmitted from a server to a client to update a view (display screen) of the client. A response to the update-view message is returned as a view-updated message to the server.

This update-view message is one of messages whose failure will make it impossible to further continue the process. Therefore, the first bit of the update-view message is set so as to indicate that the process should be terminated if a failure occurs.

A view-updated message is a message returned as a response to the update-view message received from the server. The data part of the view-updated message includes a flag indicating whether or not the view has been successfully updated.

A begin-data-input message is transmitted from a server to a client to request the client to begin inputting data to a device. An end-data-input message is returned from the client as a response to the begin-data input message.

This begin-data-input message is one of messages whose failure will make it impossible to further continue the process.

Therefore, the first bit of the begin-data-input message is set so as to indicate that the process should be terminated if a failure occurs.

The data part of the end-data-input message returned from the client as the response to the begin-data-input message includes a flag indicating whether or not data has been successfully input and also includes information indicating property name length, the property name, the property value length, and the property value.

An operate-device message is transmitted from a server to a client to request the client to operate a device connected to the client.

A device-response message is returned from the client as a response to the operate-device message.

This operate-device message is one of messages whose failure will make it impossible to further continue the process. Therefore, the first bit of the operate-device message is set so as to indicate that the process should be terminated if a failure occurs.

The data part of the operate-device message includes information indicating the number of characters of the operation name, the operation name, the parameter length, and the parameter.

A device-response message is transmitted from a client to a server to inform the result of the operation performed on the device. The data part of the device-response message includes information indicating the response length and the response.

A play-sound message is transmitted from a server to a client to request the client to generate a sound corresponding to a logical name specified by the server. No response to the play-sound message is returned.

The play-sound message is one of messages whose failure at the client will not cause the process to be terminated. Therefore, the first bit of the play-sound message is set so as to indicate that the process should be continues if a failure occurs.

The data unit of the play-sound message includes information indicating the logical name of the sound to be generated.

Referring to a sequence flow shown in FIG. 19, the operate entity protocol, in which messages shown in FIG. 18 are transmitted, is described below.

In step S191, the operate-entity message manager 67 of the server 2 produces a set of meaningful operate-entity messages to be transmitted to the portable telephone 5. The produced operate-entity messages are supplied to the operate-entity message transmission controller 68.

In step S192, the operate-entity message transmission controller 68 of the server 2 adds a finished message to the sequence of the produced messages and transmits a packet including the sequence of messages and the finished message to the portable telephone 5.

The operate-entity messages included in the control packet transmitted to the portable telephone 5 is received in step S181 and the finished message is received in step S182.

In step S183, the operate-entity message manager 97 of the portable telephone 5 produces a response to the operate-entity message received from the server 2, under the control of the controller 81. Whether or not responses are returned and how many responses are returned depend on messages received from the server 2.

In step S184, the operate-entity message transmission controller 65 of the portable telephone 5 adds a finished message to the response produced by the operate-entity message manager 97 and transmits a packet including the response and the finished message to the server 2.

In step S193, the operate-entity messages included in the packet transmitted from the portable telephone 5 are received

by the operate-entity message reception controller 69 of the server 2, and the finished message added at the end of the sequence of the operate-entity messages is received in step S194.

The sequence of operate-entity messages transmitted from the portable telephone 5 or the server 2 may include a particular number of application-specific messages (operate-entity extension message specified in the extension field).

As described above, in the neutral state (FIG. 5) after handshaking has been successfully performed between the portable telephone 5 and the server 2, the server 2 takes the initiative in communication. That is, in the neutral state, the server 2 transmits, to the portable telephone 5, messages using the update entity protocol, the application data transfer protocol, or the operate entity protocol (note that communication is started by the server 2 in any of communication sequence using the update entity protocol described above with reference to FIG. 15, communication sequence using the application data transfer protocol described above with reference to FIG. 17, and communication sequence using the operate entity protocol described above with reference to FIG. 19).

That is, in this neutral state, communication is performed not in such a manner that a response is returned from the server 2 to the portable telephone 5 and a device connected to the portable telephone 5 is controlled in accordance with the response, but in such a manner that the device is controlled in accordance with a command directly transmitted from the server 2 to the portable telephone 5.

This means that once communication is established, the server 2 can directly control a device via communication.

Referring to FIG. 20, a sequence of processes performed by a server (server 2) and a client (portable telephone 5) via communication using the above-described subprotocols in the neutral state is described below.

In step S211 in FIG. 20, the server 2 transmits, to the portable telephone 5, a control packet (application-data-transfer packet) 201 including an application-data-transfer message A (MsgA), an application-data-transfer message B (MsgB), and a finished message placed at the end of the sequence of messages MsgA and MsgB.

In communication using the application data transfer protocol, as described above with reference to FIG. 17, the application-data-transfer message transmission controller 62 of the server 2 produces a control packet by adding a finished message at the end of a sequence of a particular number of application-data-transfer messages and transmits the resultant control packet to the portable telephone 5.

In step S211, a control packet (operate entity packet) 202 is produced by adding a finished message at the end of an operate-entity message X (MsgX), and the produced control packet is transmitted from the server 2 to the portable telephone 5.

In communication using the operate entity protocol, as described above with reference to FIG. 19, the server 2 produces a control packet by adding a finished message at the end of a sequence of a particular number of operate-entity messages and transmits the resultant control packet to the portable telephone 5.

Furthermore, in this step S211, a control packet (application data transfer packet) 203 is produced by adding a finished message at the end of an application-data-transfer message C (MsgC), and the produced control packet is transmitted from the server 2 to the portable telephone 5.

As described above, a plurality of control packets are transmitted at a time to the portable telephone 5, and thus the

number of times that communication is performed can be reduced compared with the case in which the control packets are transmitted separately.

The messages included in the controls packets transmitted from the server 2 are processed by the portable telephone 5 and responses are produced in the same order as the order in which the messages were transmitted. The responses produced by the portable telephone 5 are returned to the server 2 in the same order as the order in which the responses were produced.

In the example shown in FIG. 20, when the control packets 201 to 203 are received in step S201 by the portable telephone 5, the portable telephone 5 performs processes in accordance with the received messages in the order of the application-data-transfer message A, the application-data-transfer message B, the operate-entity message X, and the application-data-transfer message C.

As described above, if an error occurs in the middle of a process according to a message, whether the following process should be continued or terminated is determined according to the value of the first bit of the message.

In the example shown in FIG. 20, it is assumed that all transmitted messages are performed successfully. The application-data-transfer message A and the operate-entity message X need a response, but the application-data-transfer message B and the application-data-transfer message C do not need a response.

For a message that must be managed by the server 2 in terms of whether or not the process has been performed successfully by the portable telephone 5, the portable telephone 5 produces a response.

Thus, after the completion of the process according to the application-data-transfer message A, the portable telephone 5 produces, in step S202, a response A (ResA) to the application-data-transfer message A and returns a response packet (application-data-transfer packet) 211 produced by adding a finished message to the response A to the server 2.

In the communication using the application data transfer protocol, as described above with reference to FIG. 17, the application-data-transfer message manager 92 produces a responses to an application-data-transfer message included in the control packet received from the server 2 and returns to the server 2 a response packet including the produced response and a finished message via the application-data-transfer message transmission controller 92.

Furthermore, after completion of the process according to the operate-entity message X, the portable telephone 5 produces, in step S202, a response X (ResX) to the operate-entity message X and returns to the server 2 a response packet (operate-entity packet) 212 produced by adding a finished message to the response X.

In the communication using the operate-entity protocol, as described above with reference to FIG. 19, the operate-entity message manager 97 produces a response to an operate-entity message included in the control packet transmitted from the server 2 and returns a response packet including the produces response and a finished message to the server 2 via the operate-entity message transmission controller 98.

The portable telephone 5 has to return to the server 2 a response packet for each control packet received from the server 2 regardless of whether or not the response packet includes a response message. Therefore, even in the case in which the application-data-transfer message C does not need a response, a response packet (application-data-transfer packet) 213 including only a finished message to the control packet 203 is returned to the server 2 in step S202.

In step 212, the response packet transmitted from the portable telephone 5 is received by the server 2. From the response included in the response packet, the server 2 recognizes that the portable telephone 5 has successfully performed the process according to the message.

As described above, because response messages are produced in the same order as the order in which messages were transmitted from the server 2, the server 2 and the portable telephone 5 can manage transmitted messages and response messages in relation to each other.

FIG. 21 shows another sequence of processes performed by the server 2 and the portable telephone 5.

In step S231 in FIG. 21, as in the case of the sequence shown in FIG. 20, control packets 221 and 223 are transmitted from the server 2 to the portable telephone 5.

In the example shown in FIG. 21, it is assumed that the portable telephone 5 fails to perform a process according to an application-data-transfer message A (MsgA) transmitted from the server 2 to the portable telephone 5. Furthermore, it is also assumed that the first bit of the application-data-transfer message A indicates that if a failure occurs in the process of the application-data-transfer message A, the process should be terminated.

Thus, when the portable telephone 5 acquires, in step S221, the application-data-transfer message A included in the control packet 221, if the portable telephone 5 fails to perform the process according to the acquired message, the portable telephone 5 does not perform processes according to following messages, that is, an application-data-transfer message B, an operate-entity message X, and an application-data-transfer message C.

When the portable telephone 5 fails to the process according to the application-data-transfer message A, the portable telephone 5 produces a response A (ResA) to inform the server 2 that the process has been failed. In step S222, the portable telephone 5 produces a response packet (application-data-transfer packet) 231 by adding a finished message to the produced response A and returns the resultant response packet 231 to the server 2.

In step S232, the server 2 receives the response packet 231 transmitted from the portable telephone 5. From the response A included in the response packet 231, the server 2 recognizes that the portable telephone 5 has failed to perform the process according to the application-data-transfer message A. The server 2 also recognizes that processes according to the application-data-transfer message B, the operate-entity message X, and the application-data-transfer message C have not been performed.

FIG. 22 shows another example of a sequence of processes performed by the server 2 and the portable telephone 5.

In step S251 in FIG. 22, as in the case of the sequences shown in FIGS. 20 and 21, control packets 241 and 242 are transmitted from the server 2 to the portable telephone 5.

In the example shown in FIG. 22, it is assumed that the portable telephone 5 fails to perform a process according to an application-data-transfer message B (MsgB) transmitted from the server 2 to the portable telephone 5. Furthermore, it is also assumed that the first bit of the application-data-transfer message B is set so as to indicate that if a failure occurs in the process of the application-data-transfer message B, the process should be continued.

The application-data-transfer message A and the operate-entity message X need a response message, but the application-data-transfer message C does not need a response message.

## 25

Thus, in step S241, the portable telephone 5 receives a control packet 241, performs a process according to the application-data-transfer message A, and produces a response A (ResA).

If the portable telephone 5 fails to perform the process according to the next message, that is, the application-data-transfer message B, the portable telephone 5 continues the following process because the first bit of the application-data-transfer message B indicates that the following process should be continued. That is, the portable telephone 5 performs a process according to the operate-entity message X included in the control packet 242 and produces a response X (ResX) to the operate-entity message X.

After completion of producing the response X, the portable telephone 5 performs a process according to the application-data-transfer message C included in the control packet 243.

In step S242, a response packet (application-data-transfer packet) 251 including the response A and a finished packet, a response packet (operate-entity packet) 252 including the response X and a finished packet, and a response packet (application-data-transfer packet) 253 including a finished packet are produced by the portable telephone 5 and returned to the server 2.

In step S252, the response packets transmitted from the portable telephone 5 are received by the server 2. From those response packets, the server 2 recognizes that the processes according to the application-data-transfer message A and the operate-entity message X have been successfully performed by the portable telephone 5 but the process according to the application-data-transfer message B has been failed. Thereafter, the sequence of processes is ended.

In the neutral state, packets are repeatedly transmitted/received between the server 2 and the portable telephone 5 in the above-described manner, and the client (device) is controlled by the server.

Although in the embodiment described above, transmitting of messages to the portable telephone 5 and returning of responses to the server 2 are repeatedly performed to control a particular device, the server 2 may transmit a script (simple program) together with a control packet to the portable telephone 5, and the portable telephone 5 may determine what process to perform next in accordance with the script and the result of the previous process according to the message.

In this case, the script indicates what process should be performed in accordance with which message, depending on a response (response of a device) produced for each message.

After completion of processes according to the script, responses returned from the device to the portable telephone 5 are all described in a response packet and transmitted to the server 2.

On the basis of the script execution history (information indicating in what order what messages were transmitted from the portable telephone 5 to the device (what messages were processed by the portable telephone 5)) transmitted to the server 2, the server 2 can determine which response transmitted from the portable telephone 5 corresponds to which message.

Although in the embodiment described above, after communication is established according to the handshake protocol, communication between the server 2 and the portable telephone 5 is performed under the initiative of the server 2, the portable telephone 5 may take the initiative of communication with a particular timing.

The change in the initiative of communication is performed, for example, using a server-client transmission direction reverse protocol.

## 26

For example, when communication is being performed under the initiative of the server 2, if an exchange message is transmitted from the server 2 to the portable telephone 5 using the server-client transmission direction reverse protocol with a particular timing, the following communication is performed in a similar manner as described above but under the initiative of the portable telephone 5.

When communication is being performed under the initiative of the portable telephone 5, if an exchange message is transmitted from the portable telephone 5 to the server 2 using the server-client transmission direction reverse protocol (exchange protocol) with a particular timing, the initiative is transferred to the server 2 and the following communication is performed under the initiative of the server 2.

FIGS. 23 and 24 show exchange protocol sequences.

In the case of the sequence shown in FIG. 23, the portable telephone 5 (client) has the initiative of communication at first. An exchange message is transmitted, in step S301, from the portable telephone 5 and received by the server 2 in step S311. Thereafter, communication between the server 2 and the portable telephone 5 is continued under the initiative of the server 2.

In the case of the sequence shown in FIG. 24, the server 2 has the initiative of communication at first. An exchange message is transmitted, in step S331, from the server 2 and received by the portable telephone 5 in step S321. Thereafter, communication between the server 2 and the portable telephone 5 is continued under the initiative of the portable telephone 5.

The manner in which the initiative of communication is exchanged in the neutral state has been described above.

In the case in which a firewall of the portable telephone 5 exists in the communication channel established between the server 2 and the portable telephone 5, communication between the server 2 and the portable telephone 5 is performed using HTTP via the firewall. In this case, all packets using the protocols described above are transmitted/received in a single session that is maintained during the whole communication.

FIG. 25 shows another example of state transitions of control protocols, which may be employed instead of state transitions shown in FIG. 5. In the following discussion, similar processed to those in FIG. 5 are not described.

In step S343, after completion of the handshake protocol, a client transmits a client-hello-done message to a server. In response, connection is established, and the initiative of the control is transferred to the server.

In step S344, in the neutral state, communication is performed, under the initiative of the server, using an update-entity subprotocol, an update-entity subprotocol, and an operate-entity subprotocol. In this communication, the initiative is transferred, as required, using an exchange message.

If the server determines that the farewell protocol is completed, then, in step S346, the server transmits a server-good-bye-done message to the client and ends the connection. The resource of the client is released and the process is ended.

As described above, the process is also ended by transmitting a server-good-bye-done message.

In the example shown in FIG. 26, the connection is ended when a client-hello-done message is transmitted from a client to a server.

That is, in step S361, a client-hello message is transmitted from a client to a server. In the next step S362, a devices message is transmitted.

In step S363, an application-specific message is transmitted. In the next step S364, a client-hello-done message is transmitted, and connection between the server and the client is established.

Meanwhile, in steps S371 to S374, the server receives the client-hello message, the client-hello message, the application-specific message, and the application-specific message, transmitted from the client.

For example, in the case in which the client is a portable telephone or a similar device, connection between the client and the server may be established via the above-described sequence that is simplified compared with the sequence shown in FIG. 8.

FIG. 27 shows another example of a sequence in which a farewell protocol is ended when a server-good-bye-done message is transmitted from a server to a client.

In this sequence, the farewell protocol starts when a server transmits a server-good-bye message in step S391. In the next step S392, a return-code message is transmitted. In step S393, an application-specific message is transmitted.

In step S394, the server transmits a server-good-bye-done message to the client, and the connection is closed.

The server-good-bye message, the return-code message, the application-specific message, and the server-good-bye-done message, transmitted from the server, are received by the client in steps S381 to S384. In response to receiving the server-good-bye-done message, the resource of the client is released.

In the case in which the client is a portable telephone or a similar device, as in the handshake protocol, the connection between the client and the server may be ended via the above-described sequence that is simplified compared with the sequence shown in FIG. 10.

The processing sequence described above may be executed by hardware or software.

When the processing sequence is executed by software, a program forming the software may be installed from a storage medium or via a network onto a computer which is provided as dedicated hardware or may be installed onto a general-purpose computer capable of performing various processes in accordance with various programs installed thereon.

Specific examples of storage media usable for the above purpose include, as shown in FIG. 2, a magnetic disk 41 (such as a floppy disk), an optical disk 42 (such as a CD-ROM (Compact Disk-Read Only Memory) and a DVD (Digital Versatile Disk)), a magneto-optical disk 43 (such as a MD (Mini-Disk (registered trademark))), and a semiconductor memory 44, in the form of a package medium on which a program is stored and which is supplied to a user separately from a computer. A program may also be supplied to a user by preinstalling it on a built-in ROM 32 or a storage unit 38 such as a hard disk disposed in a computer.

In the present description, the steps described in the program stored in the storage medium may be performed either in time sequence in accordance with the order described in the program or in a parallel or separate fashion.

In the present description, the term "system" is used to represent an entire set of apparatuses.

As can be understood from the above description, the present invention provides great advantages. That is, the present invention makes it possible for an information processing apparatus and an information terminal to communicate with each other, in particular, in a manner in which the information processing apparatus takes the initiative of communication.

The present invention makes it possible to transmit/receive various packets in a highly reliable and efficient manner,

thereby making it possible for an information processing apparatus to control an information terminal in a highly reliable and efficient manner. The high-efficiency communication allows a reduction in communication cost.

Furthermore, the present invention makes it possible for a client to continue a process even if an error occurs in the middle of the process.

What is claimed is:

1. A control system comprising an information processing apparatus and an information terminal connected with each other via a network, the system comprising:

the information terminal comprising:

request means for, in a state in which a device is connected with the information terminal, requesting the information processing apparatus to establish communication via the network;

receiving means for receiving a packet, including a command for controlling the device, and a script indicating processes to be performed to complete the command, from the information processing apparatus via communication established in response to the request issued by the request means; and

control means for controlling the device in accordance with the command included in the packet received by the receiving means,

the information processing apparatus comprising:

establishment means for establishing communication performed via the network between the information processing apparatus and the information terminal, in response to the request issued by the information terminal; and

transmission means for transmitting the packet to the information terminal from the information processing apparatus after the communication with the information terminal is established by the establishment means,

wherein the command includes information indicating whether, when the information terminal fails to perform a process to be performed in order to complete the command, an other process should be continued in accordance with a following command, part of the processes in the script for controlling the device are performed in the information terminal, and after the processes in the script are performed, a response packet, including responses from the device to the information terminal, is transmitted to the information processing apparatus.

2. A control method for controlling a control system comprising an information processing apparatus and an information terminal connected with each other via a network, the method comprising an information processing method associated with the information terminal and an information processing method associated with the information processing apparatus,

the information processing method associated with the information terminal comprising:

in a state in which a device is connected with the information terminal, requesting the information processing apparatus to establish communication via the network;

receiving a packet, including a command for controlling the device, and a script indicating processes to be performed to complete the command, from the information processing apparatus via communication established in response to the request issued in the requesting; and



controlling the device in accordance with the command included in the packet received in the receiving, the information processing method associated with the information processing apparatus comprising: establishing communication performed via the network between the information processing apparatus and the information terminal, in response to the request issued by the information terminal; and transmitting the packet to the information terminal from the information processing apparatus after the communication with the information terminal is established,

wherein the command includes information indicating whether, when the information terminal fails to perform a process to be performed in order to complete the command, an other process should be continued in accordance with a following command, part of the processes in the script for controlling the device are performed in the information terminal, and after the processes in the script are performed, a response packet, including responses from the device to the information terminal, is transmitted to the information processing apparatus.

**3.** An information processing apparatus for controlling a device connected with an information terminal with a particular timing via the information terminal connected via a network with the information processing apparatus, the information processing apparatus comprising:

establishment means for establishing communication performed via the network between the information processing apparatus and the information terminal, in response to a request issued, in a state in which the device is connected with the information terminal, by the information terminal; and

transmission means for transmitting a first packet, including a command for controlling the device and a script indicating processes to be performed to complete the command to the information terminal from the information processing apparatus after the communication with the information terminal is established by the establishment means,

wherein the command includes information indicating whether, when the information terminal fails to perform a process to be performed in order to complete the command, an other process should be continued in accordance with a following command, part of the processes in the script for controlling the device are performed in the information terminal, and after the processes in the script are performed, a response packet, including responses from the device to the information terminal, is transmitted to the information processing apparatus.

**4.** An information processing apparatus according to claim **3**, further comprising receiving means for receiving, from the information terminal, a second packet including a response to the command transmitted from the transmission means.

**5.** An information processing apparatus according to claim **3**, wherein the first packet transmitted by the transmission means includes a plurality of commands belonging to a same protocol.

**6.** An information processing apparatus according to claim **3**, wherein the transmission means transmits, together with the first packet, a simple program for causing the information terminal to determine which process should be performed by the device.

**7.** An information processing apparatus according to claim **3**, wherein the first packet transmitted by the transmission

means includes identification information identifying the device to be controlled in accordance with the command.

**8.** An information processing apparatus according to claim **3**, wherein when the communication link includes communicating via a firewall, the transmission means transmits the first packet using HTTP as a communication protocol.

**9.** An information processing apparatus according to claim **3**, further comprising command means for commanding the information terminal to start transmitting predetermined information in the communication established by the establishment means.

**10.** An information processing apparatus according to claim **8**, wherein the transmission means maintains the communication link using HTTP established by the establishment means for a period during which a plurality of first packets are transmitted.

**11.** An information processing method for an information processing apparatus to control a device connected with an information terminal with a particular timing via the information terminal connected via a network with the information processing apparatus, the method comprising:

establishing communication performed via the network between the information processing apparatus and the information terminal, in response to a request issued, in a state in which the device is connected with the information terminal, by the information terminal; and

transmitting a packet, including a command for controlling the device, and a script indicating processes to be performed to complete the command to the information terminal from the information processing apparatus after the communication with the information terminal is established,

wherein the command includes information indicating whether, when the information terminal fails to perform a process to be performed in order to complete the command, an other process should be continued in accordance with a following command, part of the processes in the script for controlling the device are performed in the information terminal, and after the processes in the script are performed, a response packet, including responses from the device to the information terminal, is transmitted to the information processing apparatus.

**12.** A computer readable medium including computer executable instructions, wherein the instructions, when executed by a processor cause a computer to perform a process of controlling a device connected with an information terminal with a particular timing via the information terminal connected via a network with the computer, the process comprising:

establishing communication performed via the network between the information processing apparatus and the information terminal, in response to a request issued, in a state in which the device is connected with the information terminal, by the information terminal; and

transmitting a packet, including a command for controlling the device, and a script indicating processes to be performed to complete the command to the information terminal from the information processing apparatus after the communication with the information terminal is established,

wherein the command includes information indicating whether, when the information terminal fails to perform a process to be performed in order to complete the command, an other process should be continued in accordance with a following command, part of the processes in the script for controlling the device are performed in the information terminal, and after the processes in the

31

script are performed, a response packet, including responses from the device to the information terminal, is transmitted to the information processing apparatus.

**13.** An information terminal connected via a network with an information processing apparatus for remotely controlling a device, comprising:

request means for, in a state in which the device is connected with the information terminal, requesting the information processing apparatus to establish communication via the network;

receiving means for receiving a first packet, including a command for controlling the device, and a script indicating processes to be performed to complete the command, from the information processing apparatus via communication established in response to the request issued by the request means; and

control means for controlling the device in accordance with the command included in the first packet received by the receiving means,

wherein the command includes information indicating whether, when the information terminal fails to perform a process to be performed in order to complete the command, an other process should be continued in accordance with a following command, part of the processes in the script for controlling the device are performed in the information terminal, and after the processes in the script are performed, a response packet, including responses from the device to the information terminal, is transmitted to the information processing apparatus.

**14.** An information terminal according to claim **13**, further comprising transmission means for transmitting to the information processing apparatus a second packet including a response indicating a result of controlling performed by the control means on the device.

**15.** An information processing method for an information terminal connected via a network with an information processing apparatus for remotely controlling a device, the method comprising:

in a state in which the device is connected with the information terminal, requesting the information processing apparatus to establish communication via the network; receiving a packet, including a command for controlling the device, and a script indicating processes to be per-

32

formed to complete the command, from the information processing apparatus via communication established in response to the request issued in the requesting; and controlling the device in accordance with the command included in the packet received in the receiving, wherein the command includes information indicating whether, when the information terminal fails to perform a process to be performed in order to complete the command, an other process should be continued in accordance with a following command, part of the processes in the script for controlling the device are performed in the information terminal, and after the processes in the script are performed, a response packet, including responses from the device to the information terminal, is transmitted to the information processing apparatus.

**16.** A computer readable medium including computer executable instructions, wherein the instructions, when executed by a processor cause a computer to perform information processing performed between the computer and an information processing apparatus for remotely controlling a device, the process comprising:

in a state in which the device is connected with the information terminal, requesting the information processing apparatus to establish communication via the network; receiving a packet, including a command for controlling the device, and a script indicating processes to be performed to complete the command, from the information processing apparatus via communication established in response to the request issued in the requesting; and

controlling the device in accordance with the command included in the packet received in the receiving, wherein the command includes information indicating whether, when the information terminal fails to perform a process to be performed in order to complete the command, an other process should be continued in accordance with a following command, part of the processes in the script for controlling the device are performed in the information terminal, and after the processes in the script are performed, a response packet, including responses from the device to the information terminal, is transmitted to the information processing apparatus.

\* \* \* \* \*