

US007593347B2

(12) **United States Patent**
Maltsev et al.

(10) **Patent No.:** **US 7,593,347 B2**
(45) **Date of Patent:** **Sep. 22, 2009**

(54) **METHOD AND APPARATUS TO EXCHANGE CHANNEL INFORMATION**

7,106,715 B1 * 9/2006 Kelton et al. 370/338
7,149,213 B1 12/2006 Rosner et al.

(75) Inventors: **Alexander A. Maltsev**, Nizhny Novgorod (RU); **Ali S. Sadri**, San Diego, CA (US); **Vadim S. Sergeye**, Nizhny Novgorod (RU); **Sergey Tiraspolsky**, Nizhny Novgorod (RU)

(Continued)

FOREIGN PATENT DOCUMENTS

EP 0 869 647 10/1998

(73) Assignee: **Intel Corporation**, Santa Clara, CA (US)

(*) Notice: Subject to any disclaimer, the term of this patent is extended or adjusted under 35 U.S.C. 154(b) by 861 days.

(Continued)

OTHER PUBLICATIONS

(21) Appl. No.: **10/746,265**

Jang, Jiho, Kwang Bok Lee and Yong-Hwan Lee, "Transmit Power and Bit Allocations for OFDM Systems in a Fading Channel", GLOBECOM 2003, pp. 858-862.*

(22) Filed: **Dec. 29, 2003**

(Continued)

(65) **Prior Publication Data**
US 2005/0143125 A1 Jun. 30, 2005

Primary Examiner—Ricky Ngo
Assistant Examiner—Luat Phung
(74) *Attorney, Agent, or Firm*—Pearl Cohen Zedek Latzer, LLP

(51) **Int. Cl.**
H04L 12/28 (2006.01)

(52) **U.S. Cl.** **370/252; 370/311; 370/338**

(57) **ABSTRACT**

(58) **Field of Classification Search** **370/252, 370/338, 203, 328, 311**
See application file for complete search history.

(56) **References Cited**

U.S. PATENT DOCUMENTS

- 5,673,259 A 9/1997 Quick, Jr.
- 6,175,550 B1 * 1/2001 van Nee 370/206
- 6,603,801 B1 8/2003 Andren et al.
- 6,678,310 B1 1/2004 Andren et al.
- 6,711,124 B2 3/2004 Khayrallah et al.
- 6,754,170 B1 6/2004 Ward
- 6,870,888 B1 * 3/2005 Shapiro et al. 375/260
- 6,885,708 B2 4/2005 Thomas et al.
- 6,891,832 B1 * 5/2005 Chien et al. 370/395.1
- 7,016,429 B1 3/2006 Dogan et al.
- 7,039,000 B2 5/2006 You et al.
- 7,065,036 B1 6/2006 Ryan

Briefly, a method and apparatus to exchange channel state information between two or more stations are provided. The channel state information may be used to adapt a power, a transmission rate and a modulation scheme of a transmitted signal. In some embodiments of the invention, a method comprises adapting a physical layer parameter based on exchanged channel information and exchanging over a channel the adapted physical layer parameter. In particular, in some embodiments of the invention, the physical layer parameter includes a bit and power loading parameter and the method comprises calculating a bit and power loading parameter during receiving a data packet; and applying the calculated bit and power loading parameter to a portion of an exchanged data packet.

29 Claims, 4 Drawing Sheets

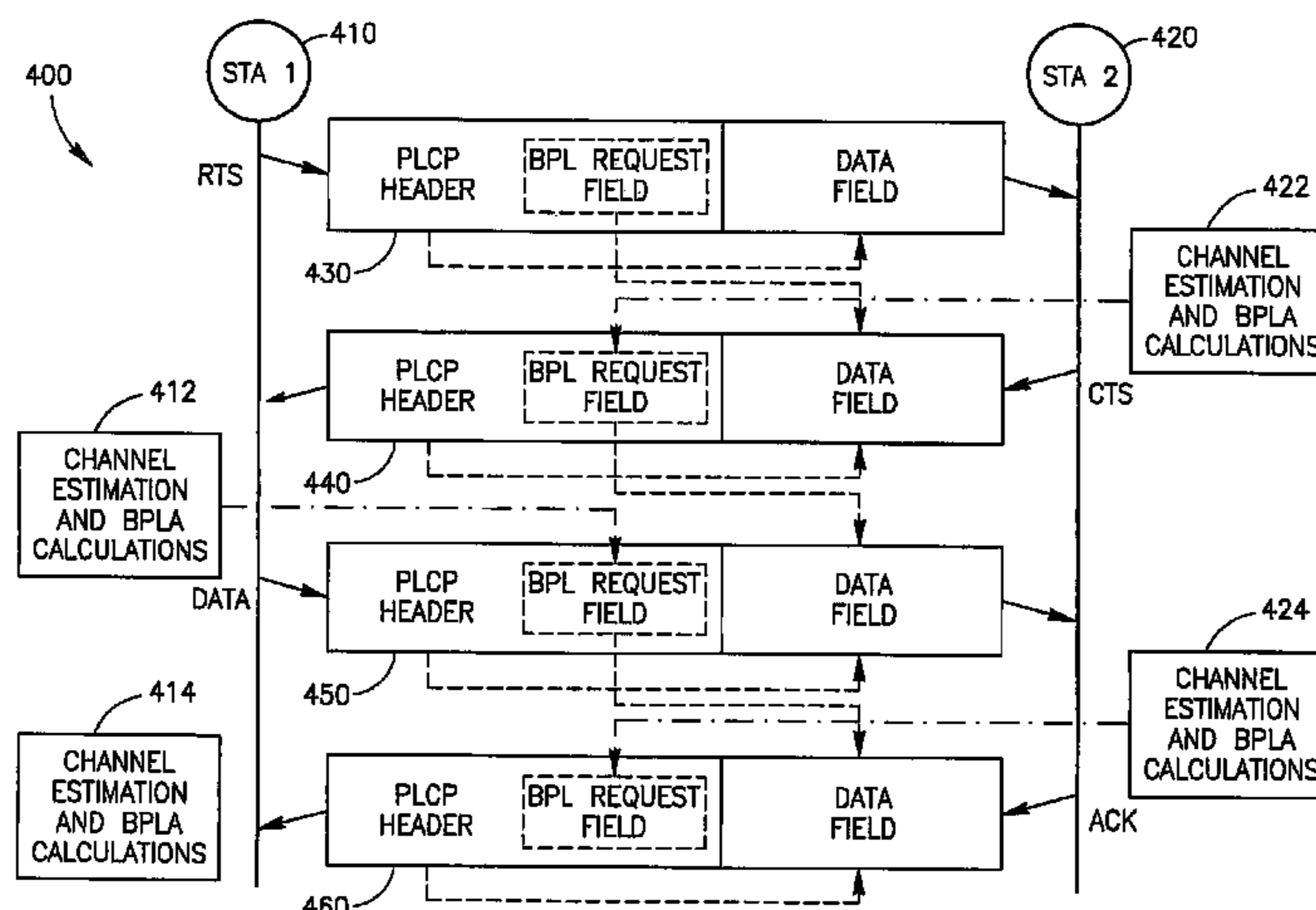

U.S. PATENT DOCUMENTS

7,295,599	B1	11/2007	Karsi	
2002/0181390	A1 *	12/2002	Mody et al.	370/208
2003/0135797	A1	7/2003	Choi	
2003/0193889	A1	10/2003	Jacobsen	
2003/0215022	A1	11/2003	Li et al.	
2003/0231715	A1	12/2003	Shoemake et al.	
2004/0047296	A1 *	3/2004	Tzannes et al.	370/252
2004/0054820	A1 *	3/2004	Karaoguz et al.	710/8
2004/0131011	A1	7/2004	Sandell et al.	
2004/0151109	A1	8/2004	Batra et al.	
2004/0151145	A1 *	8/2004	Hammerschmidt	370/338
2004/0179507	A1	9/2004	Batra et al.	
2005/0013391	A1	1/2005	Boer et al.	
2005/0058057	A1 *	3/2005	Maltsev et al.	370/203
2005/0068916	A1 *	3/2005	Jacobsen et al.	370/328
2005/0135295	A1	6/2005	Walton et al.	
2005/0135318	A1	6/2005	Walton et al.	
2005/0147075	A1 *	7/2005	Terry	370/338
2005/0243954	A1	11/2005	Li	

FOREIGN PATENT DOCUMENTS

EP	1 317 094	6/2003
EP	1 357 718	10/2003

WO WO 01/67702 9/2001

OTHER PUBLICATIONS

Zhao, Yuping and Aiping Huang, "A Novel Channel Estimation Method for OFDM Mobil Communication Systems Based on Pilot Signals and Transform-Domain Processing", IEEE 1997, pp. 2089-2093.*

Bangerter B. et al., "High-Throughput Wireless LAN Air Interface", Intel Technology Journal, vol. 7, No. 3, Aug. 19, 2003, pp. 47-57.

International Search Report for PCT/US2004/041436, mailed on Jul. 8, 2005.

Liu H. H. et al., "New frame-based network allocation vector for 802.11b multirate wireless LANs", IEEE Proceedings: Communications, Institution of Electrical Engineers, GB, vol. 149, No. 3, Jun. 14, 2002, pp. 147-151.

International Search Report for PCT/US2004/038476, mailed on Apr. 1, 2005.

U.S. Appl. No. 10/676,372, filed Sep. 30, 2003, Maltsev et al.

Intel Technology Journal, Wireless Technologies, vol. 7, Issue 3, Aug. 19, 2003, ISSN 1535-864X, pp. 1-68.

U.S. Appl. No. 10/743,309, filed Dec. 23, 2003, Maltsev et al.

First Office Action of U.S. Appl. No. 10/743,309, Filing Date Dec. 23, 2003. Mailing date of Office Action Jul. 26, 2007.

Second Office Action of U.S. Appl. No. 10/743,309, Filing Date Dec. 23, 2003. Mailing date of Office Action Jan. 9, 2008.

Final Office Action of U.S. Appl. No. 10/743,309, Filing Date Dec. 23, 2003. Mailing date of Final Office Action Jul. 3, 2008.

* cited by examiner

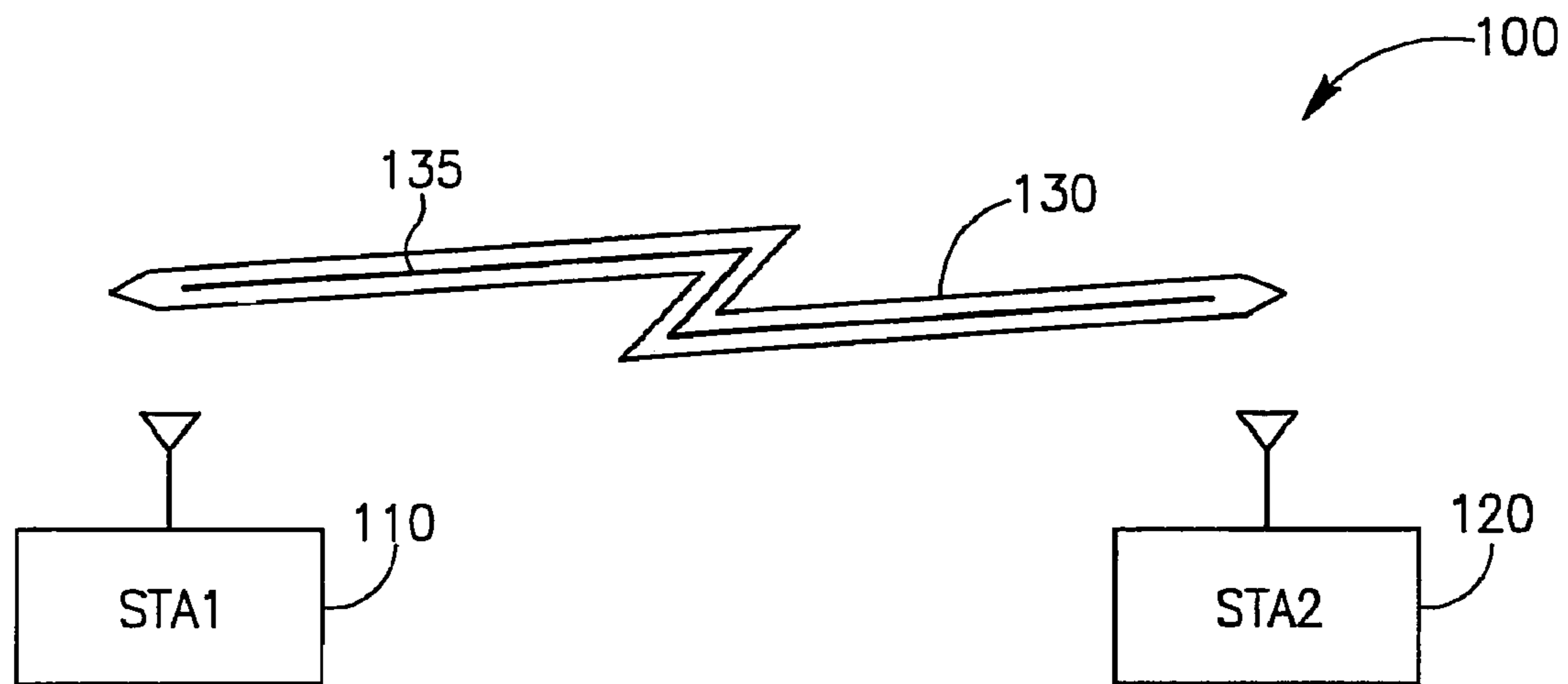

FIG. 1

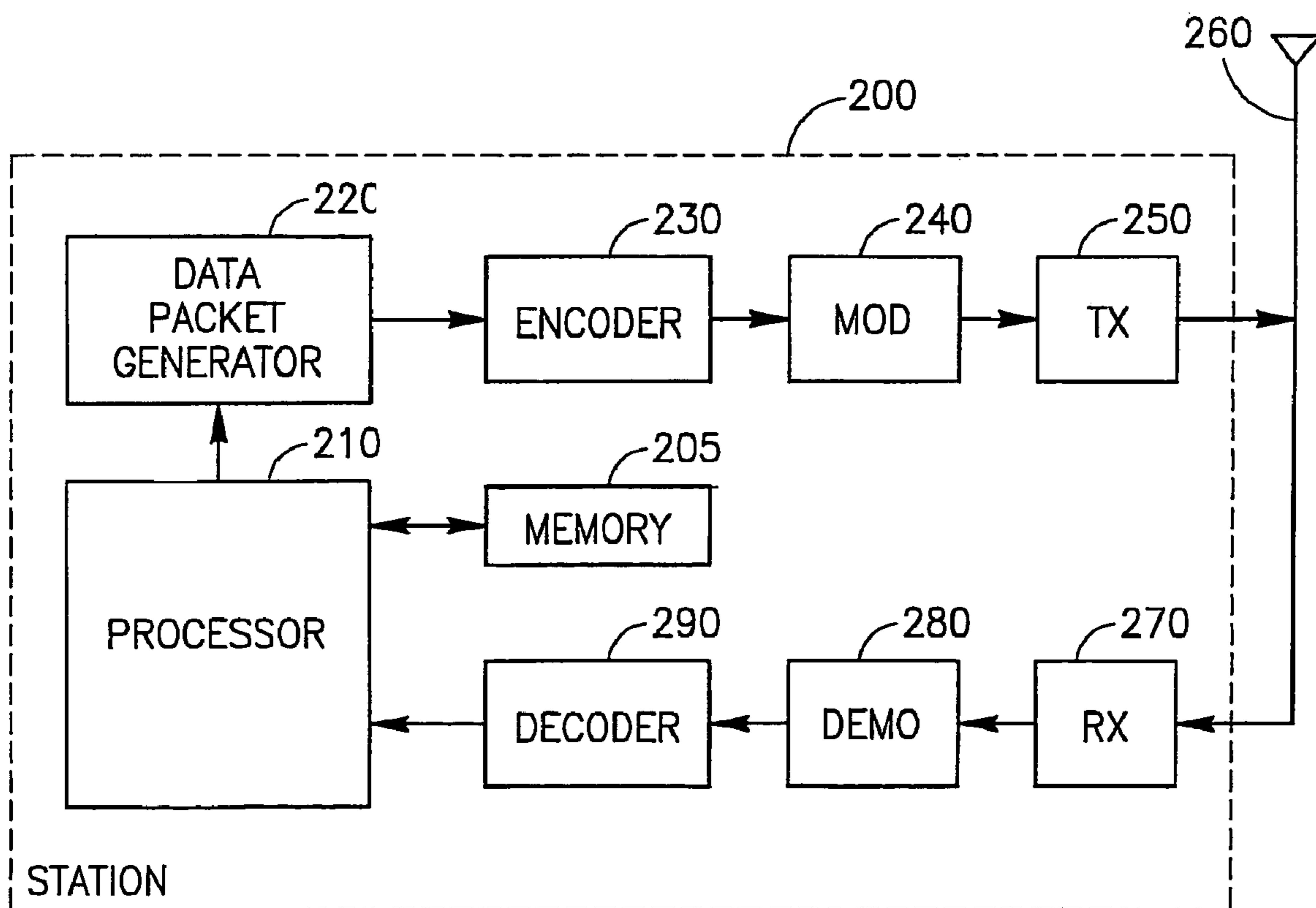
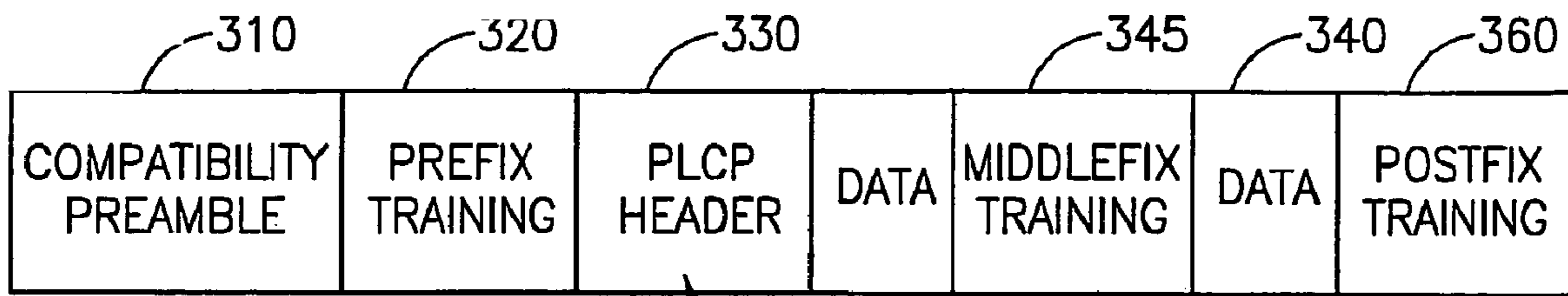

FIG. 2



300

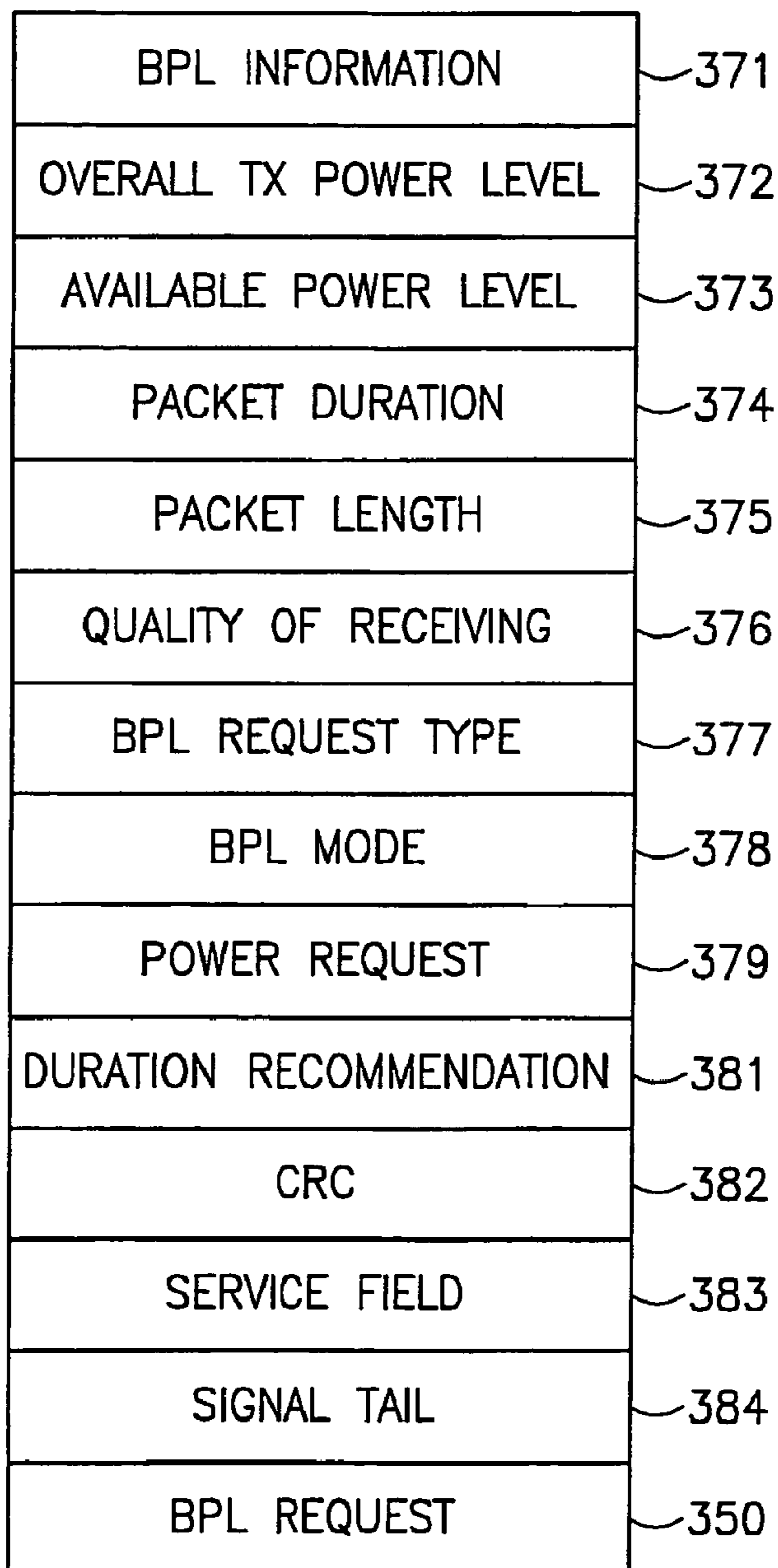

FIG. 3

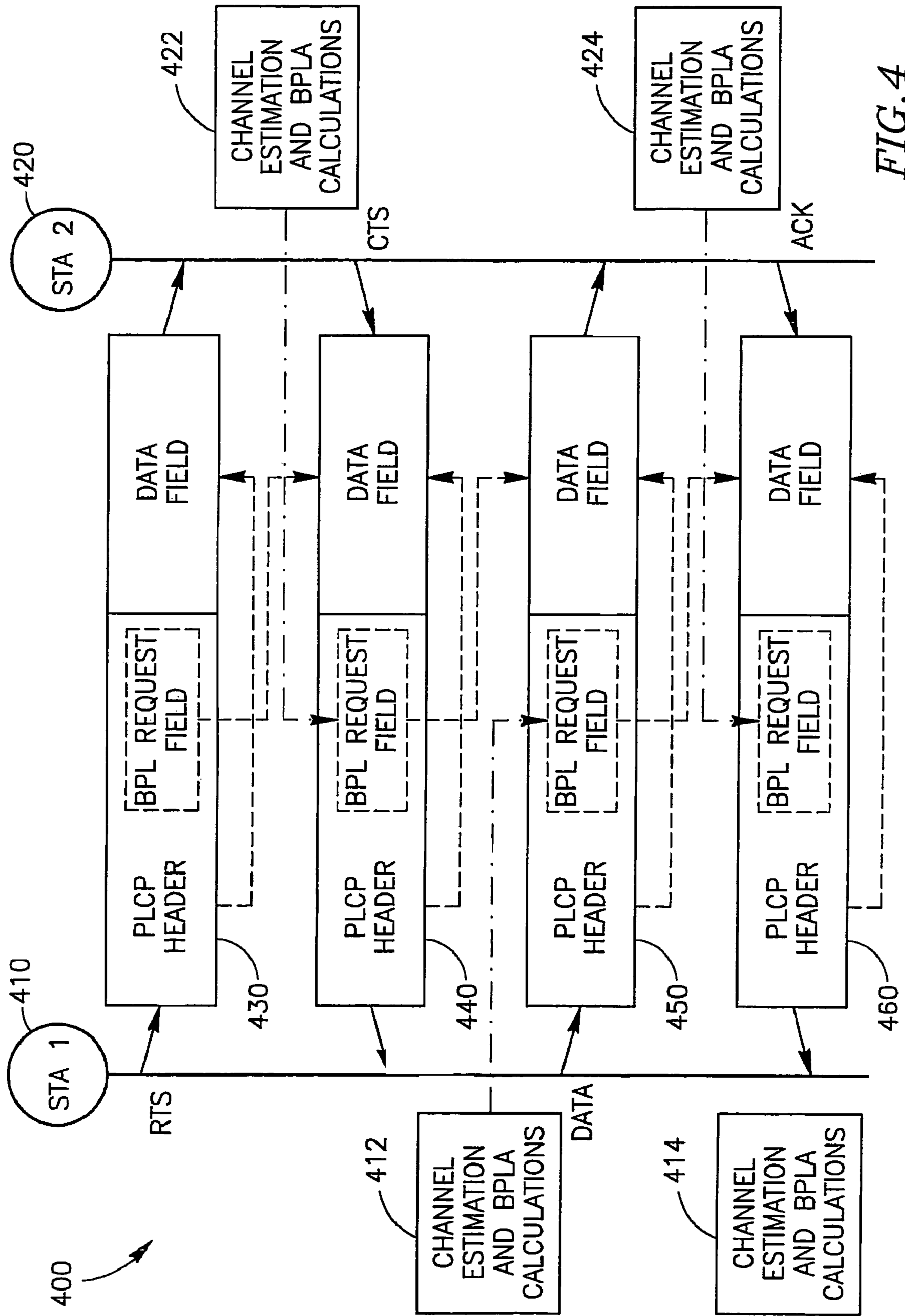

FIG. 4

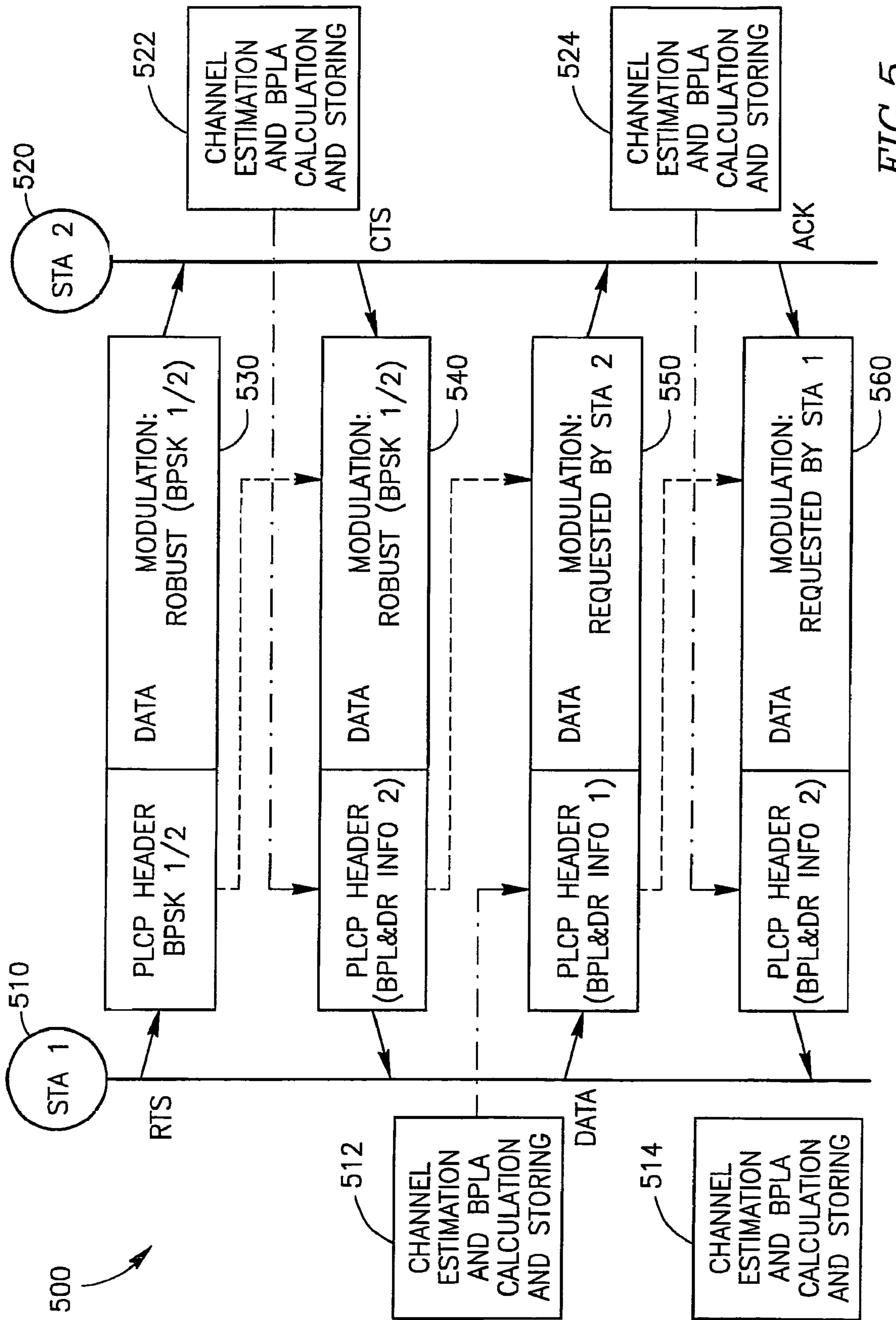

FIG. 5

METHOD AND APPARATUS TO EXCHANGE CHANNEL INFORMATION

BACKGROUND OF THE INVENTION

In wireless local area networks (WLAN), for example, WLANs that are based on IEEE-802.11-1999 standard, wideband (WB) Orthogonal Frequency Division Multiplexing (OFDM) modulation schemes or duplex time division multiplexing (TDM) modulation schemes may be used. In those systems the data rate and throughput of network may be increased by increasing spectrum bandwidth of transmitted signals and/or by using several OFDM channels in parallel and/or by applying adaptive bit and power loading (BPL) information to a data packet, if desired. An OFDM signal may include a predefined number of sub-carriers pilot signals, for example, 16 sub-carriers. The WLAN may include stations that may transmit data packets acting over a non-stationary frequency-selective shared wireless medium, which may be referred to as "channel".

For example, transmission of data packed may be done by the stations in-doors. Under these conditions the signal propagation may include multi-path and non-stationary characteristics. The multi-path may be caused by multiple scatters, for example, walls, ceilings, and various objects, and may result in frequency selectivity of a channel transfer function. Non-stationary may be caused by motion of scattering objects resulting in Doppler shift of received signal frequency. An additional non-stationary may be caused by unpredictable behavior of interferences in the same band as the data packet. These factors may result in greater Packet Error Rate (PER) and significantly reduce the throughput performance of wireless network.

BRIEF DESCRIPTION OF THE DRAWINGS

The subject matter regarded as the invention is particularly pointed out and distinctly claimed in the concluding portion of the specification. The invention, however, both as to organization and method of operation, together with objects, features and advantages thereof, may best be understood by reference to the following detailed description when read with the accompanied drawings in which:

FIG. 1 is a schematic illustration of a wireless communication system according to an exemplary embodiment of the present invention;

FIG. 2 is a block diagram of a station according to an exemplary embodiment of the present invention;

FIG. 3 is a schematic illustration of a data packet structure according to an exemplary embodiment of the present invention;

FIG. 4 is a schematic illustration of data exchange between two stations according to one exemplary embodiment of the present invention, and

FIG. 5 is a schematic illustration of data exchange between two stations according to another exemplary embodiment of the present invention.

It will be appreciated that for simplicity and clarity of illustration, elements shown in the figures have not necessarily been drawn to scale. For example, the dimensions of some of the elements may be exaggerated relative to other elements for clarity. Further, where considered appropriate, reference

numerals may be repeated among the figures to indicate corresponding or analogous elements.

DETAILED DESCRIPTION OF EMBODIMENTS OF THE INVENTION

In the following detailed description, numerous specific details are set forth in order to provide a thorough understanding of the invention. However it will be understood by those of ordinary skill in the art that the present invention may be practiced without these specific details. In other instances, well-known methods, procedures, components, and circuits have not been described in detail so as not to obscure the present invention.

Some portions of the detailed description, which follow, are presented in terms of algorithms and symbolic representations of operations on data bits or binary digital signals within a computer memory. These algorithmic descriptions and representations may be the techniques used by those skilled in the data processing arts to convey the substance of their work to others skilled in the art.

Unless specifically stated otherwise, as apparent from the following discussions, it is appreciated that throughout the specification discussions utilizing terms such as, for example, "processing," "computing," "calculating," "determining," or the like, refer to the action and/or processes of a computer or computing system, or similar electronic computing device, that manipulate and/or transform data represented as physical, such as electronic, quantities within the computing system's registers and/or memories into other data similarly represented as physical quantities within the computing system's memories, registers or other such information storage medium that may store instructions to perform actions and/or process, if desired.

Unless specifically stated otherwise, as apparent from the following discussions, it is appreciated that throughout the specification discussions utilizing terms such as, for example, "establishing", "sending", "exchanging" or the like, refer to the action and/or processes of a station of a communication system, or similar communication device, that manipulate and/or transform and/or transfer data packets over a shared physical medium, if desired.

It should be understood that the present invention may be used in a variety of applications. Although the present invention is not limited in this respect, the circuits and techniques disclosed herein may be used in many apparatuses such as stations of a radio system. Stations intended to be included within the scope of the present invention include, by way of example only, wireless local area network (WLAN) stations, two-way radio stations, digital system stations, analog system stations, cellular radiotelephone stations, and the like.

Types of WLAN stations intended to be within the scope of the present invention include, although are not limited to, mobile stations, access points, stations for receiving and transmitting spread spectrum signals such as, for example, Frequency Hopping Spread Spectrum (FHSS), Direct Sequence Spread Spectrum (DSSS), Complementary Code Keying (CCK), Orthogonal Frequency-Division Multiplexing (OFDM) and the like.

Turning first to FIG. 1, a wireless communication system 100, for example, a WLAN communication system is shown. Although the scope of the present invention is not limited in this respect, the exemplary WLAN communication system 100 may be defined, for example, by the IEEE 802.11-1999 standard, and may include at least a station 110 (STA1) and a station 120 (STA2). In some embodiments, station 110 and station 120 may transmit and/or receive one or more data

packets over a channel **130** of wireless communication system **100**. The packets may include data, control messages, network information, and the like.

Although the scope of the present invention is not limited in this respect, in some embodiments of the present invention wireless communication system may operate under IEEE 802.11-1999 and/or IEEE 802.16 standards and may transmit and/or receive orthogonal frequency division multiplexed (e.g., OFDM) communication signals. In some embodiments, the communication system may communicate an OFDM packet comprising a several OFDM symbols over a wideband communication channel. The wideband communication channel may include one or more sub-channels. The sub-channels may be frequency-division multiplexed (FDM) (i.e., separated in frequency) and may be within a predetermined frequency spectrum. In addition, the sub-channels may consist of a plurality of orthogonal sub-carriers. In some embodiments, the orthogonal sub-carriers of a sub-channel may be closely spaced OFDM sub-carriers, if desired. For example, to achieve orthogonality between closely spaced sub-carriers, in these embodiments, the sub-carriers of a particular sub-channel may have a null at substantially a center frequency of the other sub-carriers. In some embodiments of the invention, station **110** may communicate with station **120** via a link **135** that may transport OFDM signals, if desired.

Although the scope of the present inventions not limited in this respect, in OFDM WLAN systems the network throughput performance and reliability of data transmission may be increased by applying adaptive BPL per sub-carrier techniques as are known in the art, for example, a “water-filling” solution or any other suitable modulation and/or coding selection technique. These techniques may use feedback channel state information (CSI) exchange schemes, which may use feedback information transmitted from station **110** (e.g. a receiving station) to station **120** (e.g. a transmitting station). In some embodiments of the invention, a CSI exchange scheme may be used to control data transmission over channel **130** in conjunction with adaptive BPL algorithms, if desired.

In some embodiments of the present invention, a channel state information exchange sequence may include transmitting measured characteristics of channel **130** from station **110** to station **120**. In other embodiments of the invention, the channel state information exchange sequence may include transmitting from station **110** to station **120** instructions, which may allow controlling the parameters of signal transmissions by stations **110** and **120**, although the scope of the present invention is not limited in this respect. In some embodiments of the invention, these instructions may include instructions defining a modulation order of a sub-carrier, a power level of a sub-carrier and the like, which may be collectively referred to herein as BPL information. In some embodiments of the invention, these instructions may include values corresponding to differences in channel state information or in BPL information obtained by processing two or more consecutive packets, although the scope of present invention is not limited in this respect.

Although the scope of the present invention is not limited in this respect, in embodiments of the invention, at least two schemes of feedback channel information exchange, for example, a “Normal” scheme and/or “Simplified”, scheme may be applied. The “Normal” and “Simplified” feedback channel information exchange schemes may differ in an amount of information needed to perform adaptation. In those embodiments, the feedback CSI exchange scheme may be as follows: transmitter (e.g. station **110**) may incorporate into data packet information related to an overall transmitted

power. The receiving station (e.g. station **120**) may estimate the channel transfer function during reception of the transmitted data packet, may perform BPL calculations using the estimated channel transfer function and information related to the power of the transmitted packet, and may incorporate the information related to calculated optimal BPL per sub-carrier values into a response packet. The transmitting station (e.g. station **110**) may extract this BPL information and may assign modulation order per sub-carrier and/or adjust power level of the sub-carrier when transmitting a response data packet in accordance with the BPL information.

Turning to FIG. **2**, a block diagram of a station (STA) **200** according to some exemplary embodiments of the present invention is shown. Although the scope of the present invention is not limited in this respect, station **200** may include, a processor **210**, a memory **205**, a data packet generator **220**, an encoder **230**, a modulator **240**, a transmitter (TX) **250** to transmit radio frequency (RF) signals to an antenna **260**, if desired. Station **200** may further include a receiver (RX) **270** to receive an OFDM signal, which may include a data packet, a demodulator **280** and a decoder **290**.

Although the scope of the present invention is not limited in this respect, demodulator **280** may demodulate the data packet according to demodulation schemes such as, for example, binary phase shift keying (BPSK), quadrature phase shift keying (QPSK), quadrature-amplitude modulation (QAM) with different order such as, for example, QAM16, QAM32, QAM64, QAM128, QAM256 and the like, differential BPSK (DBPSK), differential QPSK (DQPSK), and the like.

Although the scope of the present invention is not limited in this respect, antenna **260** may be an omni-directional antenna, a monopole antenna, a dipole antenna, an end fed antenna, a circularly polarized antenna, a micro-strip antenna, a diversity antenna, and the like.

Although the scope of the present invention is not limited in this respect, data packet generator **220** may generate the data packet. An example of the data packet structure is described in detail below with reference to FIG. **3**. In some embodiments of the invention, processor **210** may calculate parameters of BPL during reception of other data packets from other stations. In some embodiments of the invention, processor **210** may store the calculated parameters in memory **205**. Data packet generator **220** may load BPL parameters from memory **205** to generate a response packet, if desired.

Although the scope of the present invention is not limited in this respect, encoder **230** may encode the data packet according to encoding schemes such as, for example, a convolutional encoding scheme, a block encoding scheme, a Reed-Solomon code encoding scheme, a Turbo code encoding scheme, a low-density parity-check (LDPC) encoding scheme, or the like.

Although the scope of the present invention is not limited in this respect, modulator **240** may modulate the encoded data packet on sub-carriers according to modulation schemes such as, for example, binary phase shift keying (BPSK), QPSK, quadrature-amplitude modulation (QAM) with different order such as, for example, QAM16, QAM32, QAM64, QAM128, QAM256 and the like, differential BPSK (DBPSK), differential QPSK (DQPSK), and the like. In some embodiments of present invention the modulation scheme may be chosen individually for sub-carriers of a plurality of substantially orthogonal sub-carriers.

Turning to FIG. **3**, a schematic illustration of a structure of a portion of a data packet **300** according to an exemplary embodiment of the present invention is shown. Although the scope of the present invention is not limited in this respect, the

portion of the data packet **300** may include a compatibility preamble field **310**, a prefix training field **320**, a physical layer control procedure (PLCP) header **330**, a data field **340**, a Middle-fix training field **345**, and postfix training field **360**.

Although the scope of the present invention is not limited in this respect, compatibility preamble field **310** and prefix, middle-fix and postfix training fields **320**, **345** and **360** may be used to perform tasks such as, for example, timing synchronization, coarse and fine frequency offset estimation, channel transfer function estimation, channel variation estimation and the like. In addition, compatibility preamble field **310** may carry a plurality of logical functions such as, for example, packet type detection, support of compatibility with legacy devices, possibility of a frequency division multiple access (FDMA) mode usage and the like.

Although the scope of the present invention is not limited in this respect, PLCP header **330** may include data representing a collection of parameters required to demodulate data packet **300** and/or may be used as an additional training field, if desired. In some exemplary embodiments of the invention, the over-all channel width may be 80 MHz and may include four sub-channels with a channel width of approximately 20 MHz. However, it should be understood by one skilled in the art that in other embodiments of the invention the channel width, the number of sub-channels and the width of the sub-channels may differ from those described in the above example. The information in PLCP header **330** may be encoded by encoder **230** with a convolutional code at a rate of 1/2, if desired, and may be modulated by modulator **240** with a robust modulation scheme such as, for example, binary phase shift keying (BPSK) modulation, if desired, although the scope of the invention is not limited in this respect. In addition, the PLCP header **330** may be used to perform, for example, frequency and phase offset estimation refinement, channel estimation refinement, and the like.

Although the scope of the present invention is not limited in this respect, the flowing parameters of PLCP header **330** may be used in a feedback channel state information exchange protocol for at least one of "Normal" or "Simplified" modes, if desired. In embodiments of the invention, the first parameter may be BPL Information **371**. BPL Information parameter **371** may be encoded with code rate 1/2 and may be modulated by BPSK modulation scheme. BPL Information **371** may occupy for example, 3 OFDM symbols of 4 available OFDM symbols for any desirable channel bandwidth.

Although the scope of the present invention is not limited in this respect, the second parameter may be an Overall Transmitted Power Level **372** (e.g. 4 bits). This parameter may reflect the power level, which may be used during transmission of data packet **300**. The power level may be provided with 3 dB intervals down from a predefined maximal value. This parameter in conjunction with an "Available Tx Power Level" parameter **373** and a "Power Request" parameter **379** described below may be used for solving the "Near-Far" problem, which is known to the person skilled in the art, and to perform any suitable algorithm for BPL calculation.

Although the scope of the present invention is not limited in this respect, an Available Tx Power Level parameter **373** (e.g. 4 bits) may be provided with 3 dB intervals down from a predefined maximal value. In some other embodiments of the invention, this parameter may be used in a network interface card (NIC) for a save power mode. A packet Duration parameter **374** (e.g. 2 bytes) may represent the duration of a current packet, e.g., in microseconds (μ s).

Although the scope of the present invention is not limited in this respect, PLCP header **330** of data packet **300** may include other parameters such as, for example, a Packet Length

parameter **375** (eg. 2 bytes) that may describe the length of the current data packet in octets, a Quality of Receiving parameter **376** (e.g. 2 bits) that may be transmitted as a response to a transmitter side and may include, for example, possible values, such as: "Packet Lost" (CRC failed), "Poor" (A lot of errors have been recovered by coding), "good" (a small number of errors have been recovered by coding) or "excellent" (no errors).

In addition, PLCP header **330** may include a BPL Request type parameter **377** (e.g. 2 bits) that may be used to request for BPL to be applied during a response transmission. BPL Request type parameter **377** may include values that may be used in the "Normal" mode to request BPL using instructions such as, for example: "Transmit robust", "Use BPL same as in this packet", "Use BPL same as for previous transmission", "See BPL request field **350** for BPL information" and the like. In addition, BPL Request type parameter **377** may include values that may be used in the "Simplified" mode such as, for example: the first bit may be "Is Description" bit, which may indicate whether or not the BPL information parameter **371** within PLCP header **330** may describe BPL in the packet. Furthermore, the second bit may be an "Is Request" bit that may indicate, for example, whether BPL is requested for a response data packet or BPL is not requested, thus allowing a responding station to apply BPL in accordance with the decision made at the transmitting station.

Although the scope of the present invention is not limited in this respect, a PLCP header **330** of data packet **300** may include a BPL request field **350**. BPL request field **350** may be included within PLCP header **330** of data packet **300** depending on frame type and "freshness" of available BPL request information. In some embodiments of the invention, BPL request field **350** may include parameters such as, for example, modulation types per sub-carrier, power level per sub-carrier, an overall power level, a coding type to be applied in the response packet and the like. In some embodiments of the invention, BPL request field **350** may be included into PLCP header **330** of data packet **300** in "Normal" mode and may not be included in "Simplified" mode.

Although the scope of the present invention is not limited in this respect, in addition, PLCP header **330** may include a BPL mode parameter **378** (e.g. 1 bit) to select between "Normal" and "Simplified" modes of the feedback CSI exchange, a Power Request parameter **379** (e.g. 4 bits) to request for power level to be applied during response transmission, and a Duration Recommendation parameter **381** (e.g. 6 bits) to request the duration of the packet (in units of, for example, 200 μ s) to be applied during response transmission. In addition, a CRC parameter **382** (e.g. 1 byte), a Service field parameter **383** (e.g. 1 byte) which may include a scrambler initialization and a Signal Tail parameter **384** (e.g. 6 bits) that may be used for convolutional encoding and/or decoding may also be included in PLCP header **330** of data packet **300**, if desired.

Turning to FIG. 4 a schematic illustration of data exchange between two stations **410** and **420** over a channel **400** according to one exemplary embodiment of the present invention is shown. Although the scope of the present invention is not limited in this respect, stations **410** and **420** may operate in OFDM communication system with channel information exchange, operating in 2.4 and/or 5 GHz bands. In some embodiments of the invention, the exchanged information may enable adaptation of physical layer parameters such as, for example, power level, modulation schemes, data rate, fragmentation of the data packets, or the like. The adaptation according to some exemplary embodiments of the present invention may be performed on a physical layer (e.g. of data

packet exchange protocol layers as is known to one skilled in the art) of the station without involving a medium access control (MAC) or referring to addresses of other stations.

Although the scope of the present invention is not limited in this respect, station **410** also may be referred to as “originator” and station **420** may be referred to as “recipient”. The Feedback channel state information exchange sequence between stations **410** and **420** may be as follows: sending a request to send (RTS) frame **430** by the originator (e.g. station **410**) and receiving it by the recipient (e.g. station **420**), sending a clear to send (CTS) frame **440** by the recipient (e.g. station **420**) and receiving frame **440** by the originator (e.g. station **410**), transmitting a DATA frame **450** by the originator (e.g. station **410**) and receiving frame **450** by the recipient (e.g. station **420**), sending by recipient (e.g. station **420**) an acknowledgement (ACK) frame **460**, to acknowledge the transmitted data and receiving frame **460** by the originator (e.g. station **410**). The sequence of DATA frame followed by ACK frame may be repeated until the data exchange process is completed. In some embodiments of the invention, permanent on-line link adaptation may be performed during frame exchange.

Although the scope of the present invention is not limited in this respect, frames **430**, **440**, **450** and **460** may include a PLCP header (e.g. PLCP header **330**) and a DATA field (e.g. data field **340**). In addition PLCP headers (e.g. PLCP header **330**) of frames **430**, **440**, **450** and **460** may include BPL request fields (e.g. BPL request field **350**). In some embodiments of the invention, frames **430**, **440**, **450**, **460** may be modulated on substantially orthogonal sub-carriers and may be transmitted over channel **400**. In addition, in some embodiments of the invention, the PLCP header of frames **430**, **440**, **450**, **460** may be modulated on sub-carriers in accordance with a robust modulation scheme, such as, for example, a BPSK modulation scheme.

In some embodiments of the present invention, the PLCP header of frames **430**, **440**, **450**, **460** may be encoded with a robust error-correcting code, such as, for example, a convolutional code with a coding rate of 1/2. The DATA fields of frames **430**, **440**, **450** and **460** may be modulated on sub-carriers in accordance with modulation schemes, which may be independently selected for each sub-carrier, for example, BPSK, QPSK, QAM with different order such as, for example QAM16, QAM32, QAM64, QAM128, QAM256 and the like, differential BPSK (DBPSK), differential QPSK (DQPSK), and the like. In addition, in some embodiments of the invention, the DATA fields of frames **430**, **440**, **450**, **460** may be encoded with an adaptively selected error-correcting code, such as, for example, a convolutional code with an adaptively selected coding rate, a block encoding scheme, a Reed-Solomon code, a Turbo code, a low-density parity-check (LDPC) encoding scheme, or the like.

Although the scope of the present invention is not limited in this respect, a procedure of feedback channel information exchange may be as follows: for example, station **410** may transmit RTS frame **430**. In some embodiments of the invention, station **410** may communicate in PLCP header **330** of RTS frame **430** parameters such as, for example, available transmitter power level **373**, overall transmitted power level **372** BPL request type **377**, BPL mode **378** and the like. Station **420** may receive RTS frame **430** and may perform estimation of channel characteristics such as, for example, a channel transfer function and the like (box **422**). In addition, station **420** may use at least some of prefix, middle-fix and postfix training fields (e.g. prefix and postfix training fields **320**, **360** of FIG. 3) of frame **430** to estimate the channel variation and to calculate an optimal packet duration for adap-

tive fragmentation purposes to be used during transmission of a next data packet by station **410**, if desired. Station **420** may receive within the PLCP header **330** of RTS frame **430** information such as, for example, available power level parameter **373** and overall transmitted power level parameter **372** and the like. Although the scope of the invention is not limited in this respect, station **420** may use information received from PLCP header **330** of RTS frame **430** together with, for example, channel characteristics estimates obtained by station **420**, to calculate an optimal BPL request, the duration recommendation and like parameters, and to communicate them to station **410** (box **422**).

Although the scope of the present invention is not limited in this respect, station **420** may transmit CTS frame **440** and may communicate the calculated BPL request and other parameters to station **410** in a BPL request field **350** of CTS frame **440** (dash-dotted line from box **422** in FIG. 4). The BPL request may request station **410** for modulation scheme and/or power level assignments per sub-carrier to be applied for transmission of data frame **450**. In addition, PLCP header **330** of CTS frame **440** may include parameters such as, for example, BPL information **371**, overall transmitted power level **372**, available transmitter power level **373** and the like. While receiving CTS frame **440**, station **410** may estimate the channel characteristics and may perform BPL request calculations (box **412**), which may be performed, for example, using substantially the same calculation methods used by station **420**, if desired. In addition, station **410** may use at least some of prefix, middle-fix and postfix training fields (e.g. prefix, middle-fix and postfix training fields **320**, **345**, **360** of FIG. 3) of frame **440** to estimate the channel variation and to calculate (e.g. using an optimization function) an optimal packet duration for adaptive fragmentation purposes to be used during transmission of subsequent data packets, e.g., the next data packet, by station **420**.

Although the scope of the present invention is not limited in this respect, the BPL information placed in CTS frame **440** may be compared to the BPL information calculated by station **410** to further estimate channel characteristics, such as, for example, channel variation and the like.

Although the scope of the present invention is not limited in this respect, station **410** may modulate the DATA packet (e.g. frame **450**) on sub-carriers in accordance with BPL request extracted from BPL request field **350** of CTS frame **440**. For example, station **410** may assign a requested power level and a modulation scheme for the sub-carrier, and may adjust parameters of the transmitted signal according to these assignments. In some embodiments, station **410** may place BPL information derived from estimations of the channel characteristics during reception of CTS in the BPL request field of PLCP header **330** of frame **450** (as indicated by the dashed-dotted arrow line from box **412**) and may transmit frame **450** to station **420**. During reception of DATA frame **450**, station **420** may perform channel estimation and BPL request calculations (box **424**) to request station **410** to adjust its signal parameters in accordance with this BPL request during transmission of a subsequent data frame (not shown in FIG. 4). This adjustment may be performed substantially the same way as the above-described adjustment is performed during reception of RTS frame **430**.

Although the scope of the present invention is not limited in this respect, station **420** may decide that channel **400** is static, for example, if the BPL information obtained during RTS frame **430** reception is generally or substantially the same as the BPL information obtained during reception of data frame **450**. In addition, station **420** may use at least some of prefix, middle-fix and postfix training fields (e.g. prefix, middle-fix

and postfix training fields **320**, **345**, **360** of FIG. **3**) of frame **450** to estimate the channel variation and to calculate an optimal packet duration for adaptive fragmentation purposes to be used during transmission of next data packet by station **410**.

Although the scope of the present invention is not limited in this respect, station **420** may use the BPL request type parameter **377** of PLCP header **330**, for example, as follows: if the channel is categorized as “static” by station **420**, the BPL request type parameter may be used to communicate the “Use BPL as in previous packet” instruction cause the station **410** to apply the BPL of data packet **450** to a next data packet (not shown in the FIG. **4**). In some embodiments of the invention, such use of BPL request type parameter **377** by station **420** may reduce the amount of channel state feedback information transmitted between stations **410** and **420**.

Although the scope of the present invention is not limited in this respect, station **420** may modulate the ACK frame (e.g. frame **460**) on the sub-carriers in accordance with BPL request extracted from BPL request field **350** of DATA frame **450**, if desired. For example, station **420** may assign a requested power level and/or modulation scheme for the sub-carrier and may adjust transmitted signal parameters according to this assignment.

Although the scope of the present invention is not limited in this respect, station **420** may perform the channel estimation and BPL request calculations (box **424**) and place the BPL request into BPL request field **350** in PLCP header **330** of ACK frame **460** (shown with dash-dotted arrow line from box **424**). Station **420** may confirm successive data reception by transmitting ACK frame **460** to station **410**. In some embodiments of the present invention station **410** may estimate the channel during reception of ACK frame **460** and may decide that the channel is static. In the case of such a decision, station **410** may use the BPL request type parameter of the next data frame (not shown in the FIG. **4**) to communicate the “Use BPL as in previous packet” instruction to cause station **420** to apply the BPL of ACK packet **460** to the next packet (not shown in the FIG. **4**), which may be transmitted from station **420** to station **410**. For example, such use of BPL request type parameter **377** by station **410** may further reduce the amount of channel state feedback information transmitted between stations **410** and **420**.

Turning to FIG. **5**, a schematic illustration of data exchange between two stations (e.g. stations **510**, **520**) according to another exemplary embodiment of the present invention is shown. Although the scope of the present invention is not limited in this respect, at least one notable difference between the embodiment of FIG. **4** and this embodiment may be excluding the BPL request field (e.g. BPL request field **350**) from PLCP header **330** and passing its functionality to BPL information parameter **371** of PLCP header **330** of the packet. In this case, BPL information parameter **371** of PLCP header **330** may be used to pass feedback channel state information and/or BPL information from the recipient (e.g. station **520**) to the originator (e.g. station **510**) and/or vice versa.

Although the scope of the present invention is not limited in this respect, frames **530**, **540**, **550** and **560** may include a PLCP header (e.g. PLCP header **330**) and a DATA field (e.g. DATA field **340**). In some embodiments of the invention, frames **530**, **540**, **550**, **560** may be modulated on sub-carriers in accordance with OFDM modulation schemes and may be transmitted over channel **500**. In embodiments of the present invention, the PLCP header of frames **530**, **540**, **550**, **560** may be modulated on sub-carriers in accordance with a robust modulation scheme such as, for example, a BPSK modulation scheme, and encoded with a robust error-correcting code such

as, for example, a convolutional code with a coding rate of 1/2, although the scope of present invention is not limited in this respect.

For example, the DATA fields of frames **530**, **540**, **550** and **560** may be modulated on sub-carriers in accordance with modulation schemes, which may be independently selected per sub-carrier, such as, for example, BPSK, QPSK, QAM with different order such as, for example, QAM16, QAM32, QAM64, QAM128, QAM256 and the like, DBPSK, DQPSK, and the like. In addition, in some embodiments of the present invention, the DATA fields of frames **530**, **540**, **550**, **560** may be encoded with an adaptively selected error-correcting code such as, for example, a convolutional code with an adaptively selected coding rate.

Although the scope of the present invention is not limited in this respect, station **510** may be referred to herein as “originator” and station **520** may be referred to herein as “recipient”. Although the scope of the present invention is not limited in this respect, the feedback channel state information exchange sequence between stations **510**, **520** may be as follows: sending RTS frame **530** by the originator (e.g. station **510**) and receiving frame **530** by the recipient (e.g., station **520**), sending a CTS frame **540** by the recipient (e.g. station **520**) and receiving frame **540** by the originator (e.g. station **510**), transmitting data frame **550** by the originator (e.g. station **510**) and receiving frame **550** by the recipient (e.g. station **520**), sending from the recipient (e.g. station **520**) ACK frame **560** (to acknowledge the transmitted data) and receiving frame **560** by the originator (e.g. station **510**). The sequence DATA, ACK frame transmission/reception until the data exchange process is completed. In some embodiments of the invention, permanent on-line adaptation may be performed during frame exchange.

Although the scope of the present invention is not limited in this respect, the originator (e.g. station **510**) may transmit RTS frame **530**, during which time the recipient (e.g. station **520**) may estimate different channel characteristics. Although the scope of the present invention is not limited in this respect, RTS frame **530** may be modulated on sub-carriers in accordance with a robust, e.g., the most robust, modulation scheme or any other suitable modulation scheme for the sub-carriers. The originator (e.g. station **510**) may modulate RTS frame **530** on sub-carriers in accordance with a desired, e.g., individually selected, modulation scheme of the sub-carriers, for example, the originator (e.g. station **510**) may be updated with BPL information. In some embodiments of invention, the originator (e.g. station **510**) may embed the BPL information used for transmission of RTS frame **530** into BPL information parameter **371** of PLCP header of RTS frame **530**.

In addition, the originator (e.g. station **510**) may set a first bit (e.g. an “Is Description” bit) of BPL Request parameter **377** of PLCP header **330** of RTS frame **530**, thus requesting the recipient (e.g. station **520**) to use the BPL information parameter **371** of PLCP header of RTS frame **530** to demodulate the RTS frame **530**. In addition, a second bit (e.g. “Is Request” bit) of BPL Request parameter **377** of PLCP header **330** of RTS frame **530** may be set to request the recipient (e.g. station **520**) to use similar BPL information during transmission of CTS frame **540**.

In some embodiments of the invention, the requested BPL information may be stored in a memory of the originator (e.g. station **510**) and may be used to demodulate response CTS frame **540**. In addition, “Available power level” parameter **373** and transmitted power level parameter **372** may be included in the PLCP header of RTS frame **530** that may be used together with channel estimation performed by the

recipient (e.g. station 520). "Available power level" parameter 373 and transmitted power level parameter 372 may allow the recipient (e.g. station 520) to calculate an optimal BPL request to be used by the originator (e.g. station 510) during transmission of data frame 550 in order to provide optimal receiving conditions at the recipient (e.g. station 520).

Although the scope of the present invention is not limited in this respect, recipient (e.g. station 520) may respond with CTS frame 540 modulated on sub-carriers in accordance with the modulation schemes requested by the originator (e.g. station 510) through BPL information parameter 371 together with the "Is Request" bit in BPL request type parameter 377 in the PLCP header of RTS frame 530. The BPL request calculated during reception of RTS frame 530 may be embedded by recipient (e.g. station 520) in the BPL information parameter 371 of PLCP header of CTS frame 540. The "Is Description" bit in PLCP header of CTS frame 540 may be cleared, thus causing the originator (e.g. station 510) to use its stored BPL information to demodulate the received packet. In addition, the "Is request" bit in the PLCP header of CTS frame 540 may be set to cause the originator (e.g. station 510) to modulate the data frame 550 on sub-carriers using modulation assignments and/or adjusting power levels of a sub-carrier in accordance with a BPL request communicated in BPL information parameter 371 in the PLCP header of CTS frame 540.

Although the scope of the present invention is not limited in this respect, the originator (e.g. station 510), while receiving CTS frame 540, may estimate the channel characteristics, perform BPL calculations (box 512) and may store resulting BPL information in a memory, if desired.

Although the scope of the present invention is not limited in this respect, the originator (e.g. station 510) may transmit a DATA packet 550 modulated in accordance with the BPL request communicated in the PLCP header of CTS frame 540. The BPL information parameter 371 in the PLCP header of DATA frame 550 may include BPL information calculated by the originator (e.g. station 510) during reception of CTS frame 540. The "Is Description" bit in the PLCP header of data frame 550 may be cleared, thus causing the recipient (e.g. station 520) to use its stored BPL information to demodulate the data frame 550. In addition, the "Is request" bit in the PLCP header of DATA frame 550 may be set to cause the recipient (e.g. station 520) to modulate the ACK frame 560 on sub-carriers in accordance with the BPL request communicated in BPL information parameter 371 in the PLCP header of DATA frame 550.

Although the scope of the present invention is not limited in this respect, during data reception; the recipient (e.g. station 520) may estimate different channel characteristics, which may have changed during the time period between frames 530 and 550, and calculate a BPL to be applied during the next data frame (not shown) transmission. Using both prefix and postfix training fields in the DATA packet, the recipient (e.g. station 520) may estimate the channel variation and calculate an optimal packet duration, e.g., for adaptive fragmentation purposes, to be used during transmission of the next data frame by the originator (e.g. station 510).

Although the scope of the present invention is not limited in this respects the recipient (e.g. station 520) may confirm successive data receptions by transmitting the ACK frame 560. The PLCP header of ACK frame 560 may include BPL information obtained during data packet reception to provide the originator (e.g. station 510) with updated BPL information.

Although the scope of present invention is not limited in this respect, the DATA field of ACK frame 560 may be modulated on sub-carriers in accordance with a BPL request communicated in the PLCP header of data frame 550, and originator (e.g. station 510) may demodulate the ACK frame 560 using its stored BPL information.

While certain features of the invention have been illustrated and described herein, many modifications, substitutions, changes, and equivalents will now occur to those skilled in the art. It is, therefore, to be understood that the appended claims are intended to cover all such modifications and changes as fall within the true spirit of the invention.

What is claimed is:

1. A method of communication over a wireless channel comprising:

receiving a request to send (RTS) frame that includes a header which includes a modulation scheme and a bit to select a mode of feedback channel state information (CSI) exchange scheme to exchange data between two or more stations;

calculating a bit and power loading (BPL) parameter during receiving the RTS frame based on said RTS frame header content;

adapting a physical layer parameter based on exchanged channel information and exchanging over a channel the adapted physical layer parameter, wherein the physical layer parameter includes a bit and power loading parameter;

applying the calculated bit and power loading parameter to a portion of a clear to send (CTS) frame; and modulating a portion of the CTS frame based on channel state information and said modulation scheme.

2. The method of claim 1, comprising:

providing the calculated BPL parameter to a header of the CTS frame.

3. The method of claim 1, comprising

providing information calculated based on information in a predefined field of the RTS frame to a header of the CTS frame.

4. The method of claim 1, comprising:

determining a data exchange mode according to the bit included in the header of RTS frame.

5. The method of claim 1, wherein calculating the bit and power loading parameter comprises:

estimating a channel transfer function during reception of the RTS frame; and

calculating the BPL parameter based on information related to transmitted power and the estimated channel transfer function.

6. The method of claim 1, comprising:

providing channel feedback information and information to be used to demodulate the CTS frame based on the training information included in the RTS frame.

7. The method of claim 1 comprising:

exchanging feedback information for adaptive fragmentation of exchanged one or more data packets.

8. The method of claim 1, wherein calculating the BPL parameter comprises:

estimating a signal-to-noise ratio in at least some of sub-carriers during reception of the RTS frame; and

calculating the BPL parameter based on information related to transmitted power and the estimated signal-to-noise ratio of at least some of sub-carriers.

9. An apparatus comprising:

a receiver to receive a request to send (RTS) frame that includes a header which includes a bit to select a mode of

13

feedback channel state information (CSI) exchange scheme to exchange data between two or more stations; a processor to calculate a bit and power loading (BPL) parameter during reception of the RTS frame based on said RTS frame header content;

a data packet generator to apply the BPL parameter to a portion of a clear to send (CTS) frame; and

a modulator to modulate a portion of the CTS frame based on channel state information and modulation scheme included in the header of the RTS frame.

10. The apparatus of claim 9, wherein the data packet generator is to apply the BPL parameter to a predetermined field of the CTS frame.

11. The apparatus of claim 9, wherein the data packet generator is to apply the BPL parameter to a predetermined field header of the CTS frame.

12. The apparatus of claim 9, wherein the processor is to determine a data exchange mode according to the bit included in the header of the RTS frame.

13. The apparatus of claim 9, wherein the processor is to estimate a transfer function during reception of the RTS frame and to use information relating to transmitted power in the RTS frame to calculate the BPL parameter.

14. A wireless communication station comprising:

a dipole antenna used to exchange an exchanged data packet with another wireless communication station;

a receiver to receive a request to send (RTS) frame that includes a header which includes a bit to select a mode of feedback channel state information (CSI) exchange scheme to exchange data between two or more stations; a processor to calculate a bit and power loading (BPL) parameter during reception of the RTS frame based on said RTS frame header content;

a data packet generator to apply the BPL parameter to a portion of a clear to send (CTS) frame; and

a modulator to adapt a modulation scheme of a portion of the exchanged data packet based on channel information included in the CTS frame.

15. The wireless communication station of claim 14, wherein the data packet generator is to apply the BPL parameter to a predetermined field of the exchanged data packet.

16. The wireless communication station of claim 14, wherein the data packet generator is to provide the BPL parameter to a header of the CTS frame.

17. The wireless communication station of claim 14, wherein the processor is to determine a data exchange mode according to the bit included in the header of the RTS frame.

18. The wireless communication station of claim 14, wherein the processor is to estimate a transfer function during reception of the exchanged data packet and to use information relating to transmitted power in the RTS frame to calculate the BPL parameter.

19. A wireless communication system comprising:

two or more stations to exchange data packets wherein, a station of the two or more station includes:

a receiver to receive a request to send (RTS) frame that includes a header which includes a bit to select a mode of feedback channel state information (CSI) exchange scheme to exchange data between two or more stations; a processor to calculate a bit and power loading (BPL) parameter during reception of the RTS frame based on the header content;

a data packet generator to apply the BPL parameter to a portion of a clear to send (CTS) frame; and

14

a modulator to adapt a modulation scheme of a portion of the exchanged data packet based on channel information included in the CTS frame.

20. The wireless communication system of claim 19, wherein the data packet generator is to apply the BPL parameter to a predetermined field of the exchanged data packet.

21. The wireless communication system of claim 19, wherein the data packet generator is to provide the BPL parameter to a header of the CTS frame.

22. The wireless communication system of claim 19, wherein the processor is to determine a data exchange mode according to the bit included in the header of the RTS frame.

23. The wireless communication system of claim 19, wherein the processor is to estimate a transfer function during reception of the exchanged data packet and to use information relating to transmitted power in the RTS frame to calculate the BPL parameter.

24. An article comprising: a storage medium, having stored thereon instructions, that when executed, result in:

receiving a request to send (RTS) frame that includes a header which includes a modulation scheme and a bit to select a mode of feedback channel state information (CSI) exchange scheme to exchange data between two or more stations;

calculating a bit and power loading (BPL) parameter during receiving the RTS frame based on said RTS frame header content;

adapting a physical layer parameter based on exchanged channel information and exchanging over a channel the adapted physical layer parameter, wherein the physical layer parameter includes a bit and power loading parameter;

applying the calculated bit and power loading parameter to a portion of a clear to send (CTS) frame; and

modulating a portion of the CTS frame based on channel state information and said modulation scheme.

25. The article of claim 24, wherein the instructions when executed, result in:

providing information calculated based on information in a predefined field of the RTS frame to a header of the CTS frame.

26. The article of claim 24, wherein the instructions when executed, result in:

determining a data exchange mode according to the bit included in the header of RTS frame.

27. The article of claim 24, wherein the instructions when executed, result in:

providing channel feedback information and information to be used to demodulate the CTS frame based on the training information included in the RTS frame.

28. The article of claim 24, wherein the instructions when executed, result in:

exchanging feedback information for adaptive fragmentation of exchanged one or more data packets.

29. The article of claim 24, wherein the instructions of calculating the BPL parameter when executed, result in:

estimating a signal-to-noise ratio in at least some of sub-carriers during reception of the RTS frame; and

calculating the BPL parameter based on information related to transmitted power and the estimated signal-to-noise ratio of at least some of sub-carriers.

UNITED STATES PATENT AND TRADEMARK OFFICE
CERTIFICATE OF CORRECTION

PATENT NO. : 7,593,347 B2
APPLICATION NO. : 10/746265
DATED : September 22, 2009
INVENTOR(S) : Maltsev et al.

Page 1 of 1

It is certified that error appears in the above-identified patent and that said Letters Patent is hereby corrected as shown below:

On the Title Page:

The first or sole Notice should read --

Subject to any disclaimer, the term of this patent is extended or adjusted under 35 U.S.C. 154(b) by 1261 days.

Signed and Sealed this

Twenty-first Day of September, 2010

A handwritten signature in black ink that reads "David J. Kappos". The signature is written in a cursive style with a large, looped 'D' and a long, sweeping tail for the 's'.

David J. Kappos
Director of the United States Patent and Trademark Office