



US007581653B2

(12) **United States Patent**  
**Perrin et al.**

(10) **Patent No.:** **US 7,581,653 B2**  
(45) **Date of Patent:** **Sep. 1, 2009**

(54) **CAP AND CLOSURE SYSTEM FOR CLOSING A LARGE POTABLE LIQUID BOTTLE**

4,834,267 A 5/1989 Schroer et al.  
4,846,236 A 7/1989 Deruntz

(75) Inventors: **Gerard Perrin**, Meyzieu (FR); **Henri Pionchon**, Lyons (FR)

(73) Assignee: **Crealise Packaging-Conditionnement Inc.**, Rawdon (CA)

(Continued)

(\*) Notice: Subject to any disclaimer, the term of this patent is extended or adjusted under 35 U.S.C. 154(b) by 628 days.

CA 1 291 969 11/1991

FOREIGN PATENT DOCUMENTS

(21) Appl. No.: **10/822,211**

(Continued)

(22) Filed: **Apr. 8, 2004**

*Primary Examiner*—Robin Hylton

(65) **Prior Publication Data**

(74) *Attorney, Agent, or Firm*—Miller, Matthias & Hull

US 2005/0224446 A1 Oct. 13, 2005

(57) **ABSTRACT**

(51) **Int. Cl.**  
**B65D 41/48** (2006.01)

(52) **U.S. Cl.** ..... **215/254**; 215/253

(58) **Field of Classification Search** ..... 215/254,  
215/253, 256, 250; 206/432, 497; 220/270,  
220/268

See application file for complete search history.

A threadless cap for closing a potable liquid bottle is provided. The potable liquid bottle has a neck with an upper edge defining a discharge opening. The threadless cap comprises a lid for overlying and sealingly engaging the upper edge of the neck. The lid includes a tension ring for retaining the cap on the neck of the bottle, the tension ring having an inwardly extending rib for engaging the neck of the bottle. The threadless cap also comprises a skirt depending from the lid, the skirt including a line of weakness facilitating a manual tear of the skirt. The threadless cap further comprises a tear stop at a location intersecting a line of tear propagating as a result of a manual pull applied on the skirt, the tear stop preventing the line of tear to propagate beyond the tear stop. The line of weakness may include a portion extending across the tension ring to reduce a retaining force exerted by the tension ring on the neck of the bottle when a tear line propagating as a result of a manual pull applied on the skirt extends across the tension ring. Also, provided is a closure system that includes such a threadless cap and a protective sheath for application on the cap.

(56) **References Cited**

U.S. PATENT DOCUMENTS

- 1,976,007 A 10/1934 Cullen et al.
- 2,213,465 A 9/1940 Gay
- 2,811,272 A 10/1957 Lawlor
- 3,392,862 A \* 7/1968 Faulstich ..... 215/254
- 3,840,137 A \* 10/1974 Faulstich ..... 215/256
- 3,940,103 A 2/1976 Hilaire
- 4,239,130 A 12/1980 Altadonna
- 4,243,150 A 1/1981 Gunne et al.
- 4,267,945 A 5/1981 Maynard, Jr.
- 4,597,423 A 7/1986 Chenot
- RE32,354 E 2/1987 Savage
- 4,699,188 A 10/1987 Baker et al.
- 4,717,051 A 1/1988 Leclere
- 4,735,337 A \* 4/1988 Von Holdt ..... 220/276

**34 Claims, 4 Drawing Sheets**

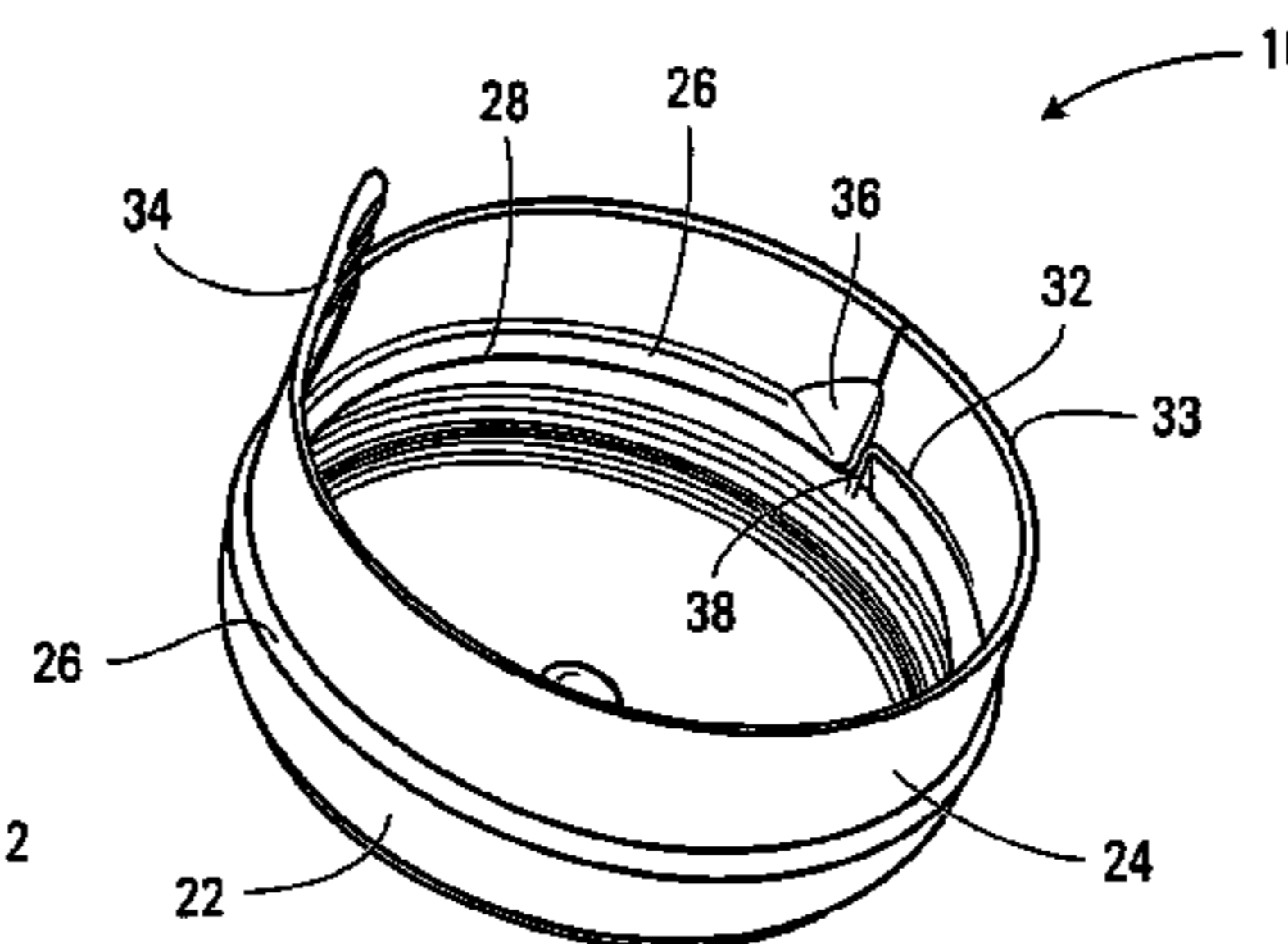
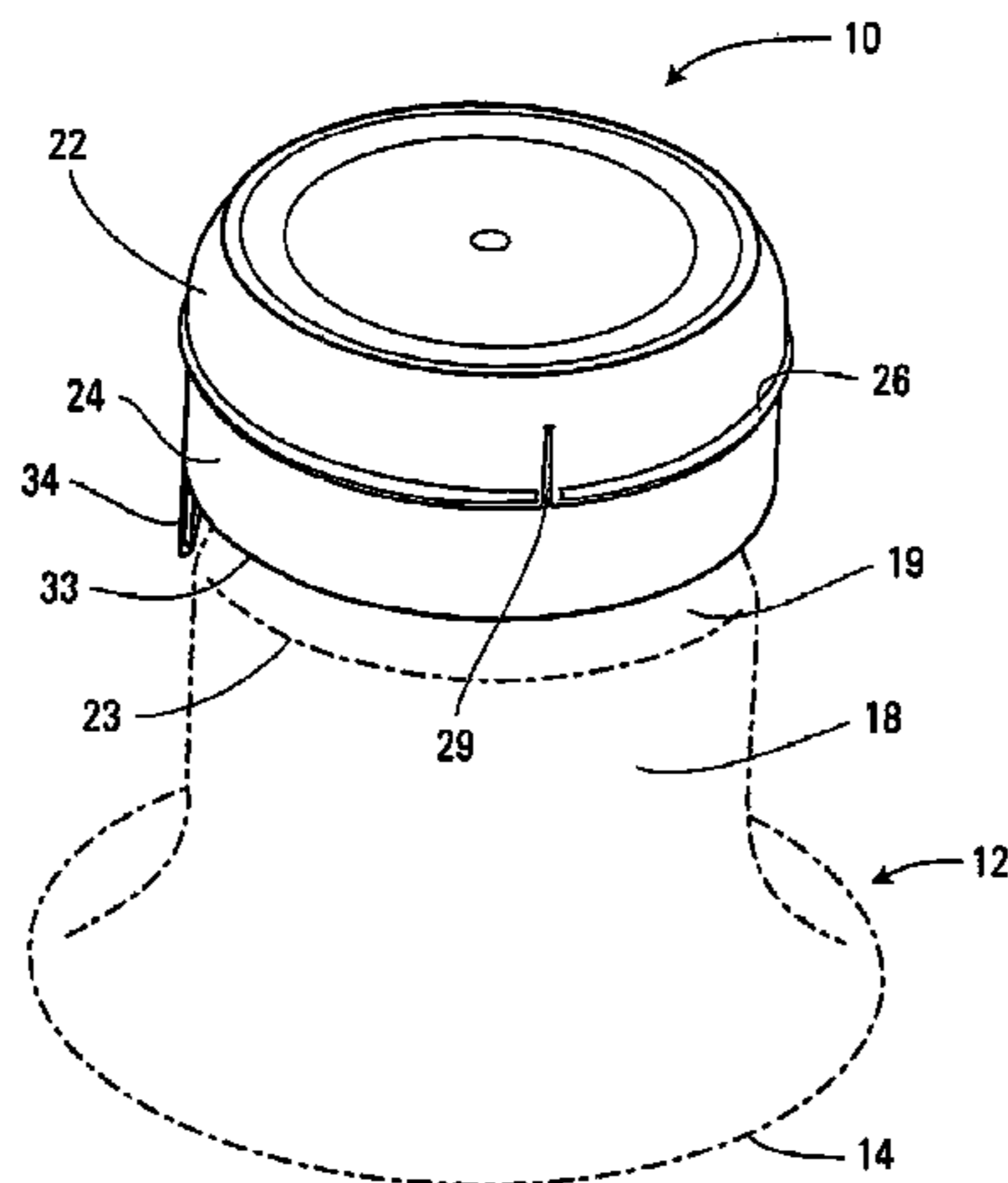

# US 7,581,653 B2

Page 2

## U.S. PATENT DOCUMENTS

4,911,316 A \* 3/1990 Tackles ..... 215/256  
4,934,546 A \* 6/1990 Markley ..... 215/256  
4,948,009 A 8/1990 Sawatani  
5,031,676 A 7/1991 Ulm  
5,121,778 A 6/1992 Baker et al.  
5,222,519 A 6/1993 Sato et al.  
5,222,530 A 6/1993 Baker et al.  
5,232,125 A 8/1993 Adams  
5,259,534 A 11/1993 Lynd  
5,273,083 A 12/1993 Burrows  
5,284,188 A 2/1994 Baker et al.  
5,289,854 A 3/1994 Baker et al.  
5,289,855 A 3/1994 Baker et al.  
5,295,518 A 3/1994 Baker et al.  
5,297,599 A 3/1994 Bucheli  
5,370,270 A 12/1994 Adams et al.  
5,397,023 A 3/1995 Toczec et al.  
5,513,763 A 5/1996 Adams et al.  
5,542,555 A 8/1996 Hidding et al.  
5,687,865 A \* 11/1997 Adams et al. .... 215/253  
5,687,867 A 11/1997 Lamoureux  
5,909,827 A 6/1999 Bietzer et al.  
5,937,921 A \* 8/1999 Guglielmini ..... 141/351

6,032,812 A 3/2000 Lamoureux  
6,177,041 B1 1/2001 Bietzer  
6,681,947 B2 \* 1/2004 Kim et al. .... 215/254  
2003/0094213 A1 5/2003 Moon et al.

## FOREIGN PATENT DOCUMENTS

CA 1 338 210 4/1996  
CA 1 338 339 5/1996  
CA 2 181 828 1/2002  
CA 2 442 213 10/2002  
CA 2 418 456 8/2004  
EP 0 918 731 B1 6/1997  
FR 2 822 810 A1 3/2001  
GB 1 104 638 3/1966  
WO WO 90/03919 4/1990  
WO WO 91/13813 9/1991  
WO WO 93/07084 4/1993  
WO WO 94/29215 12/1994  
WO WO 98/03426 1/1998  
WO WO 00/40474 A1 \* 7/2000  
WO WO 02/060808 A1 8/2002  
WO WO 02/079046 A1 10/2002  
WO WO 2004/071932 A1 8/2004

\* cited by examiner

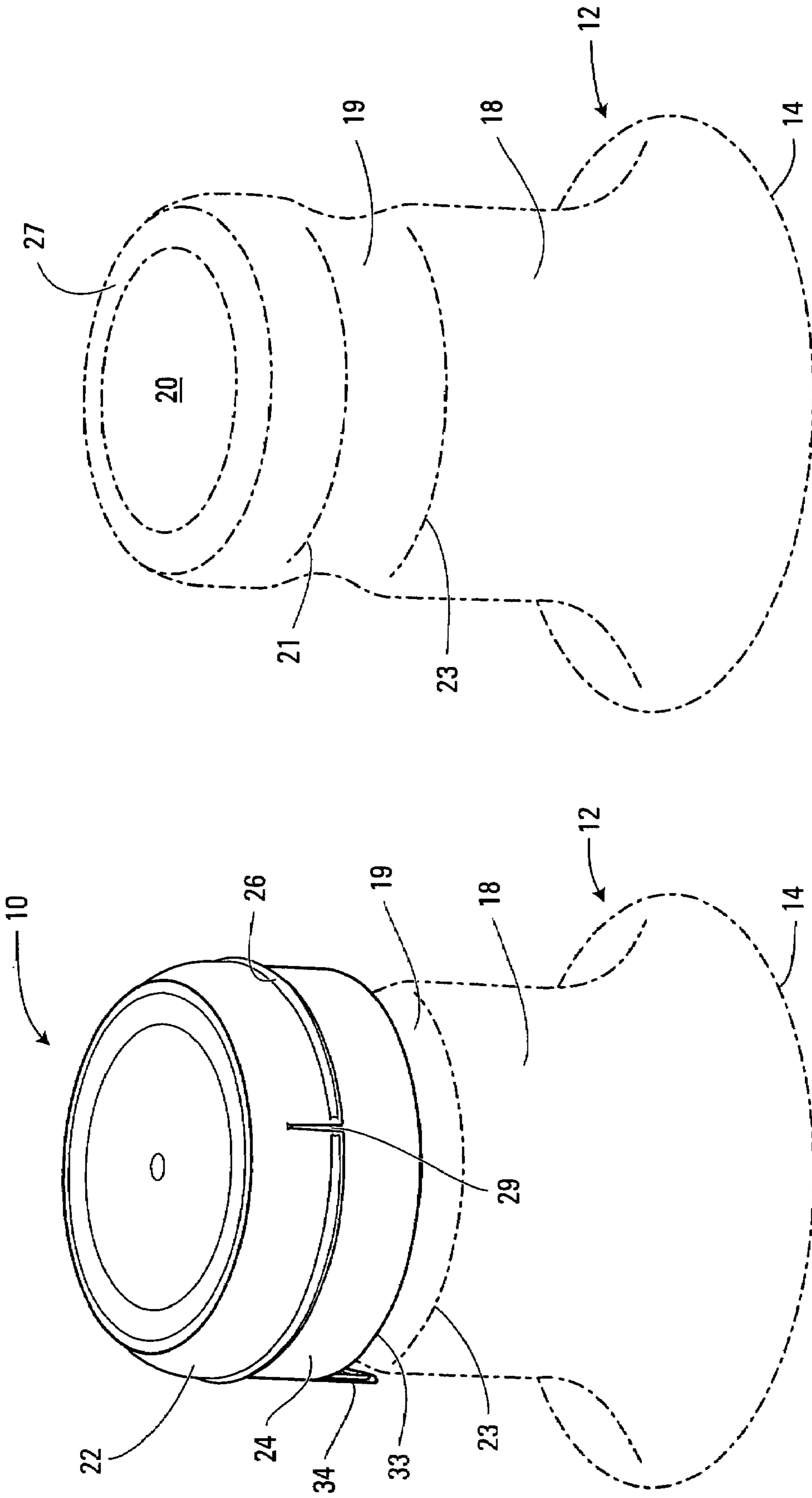

FIG. 1B

FIG. 1A

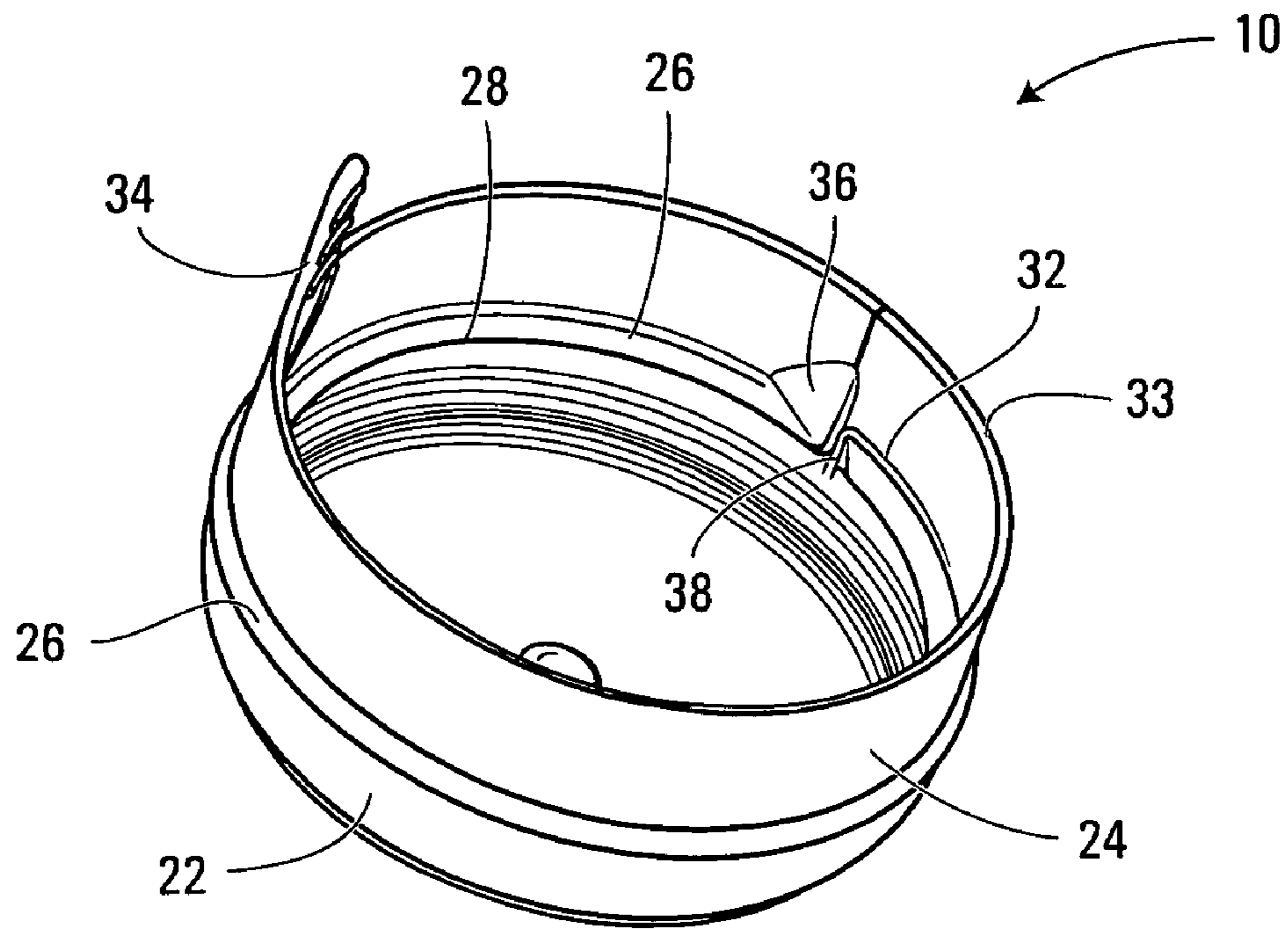

FIG. 2

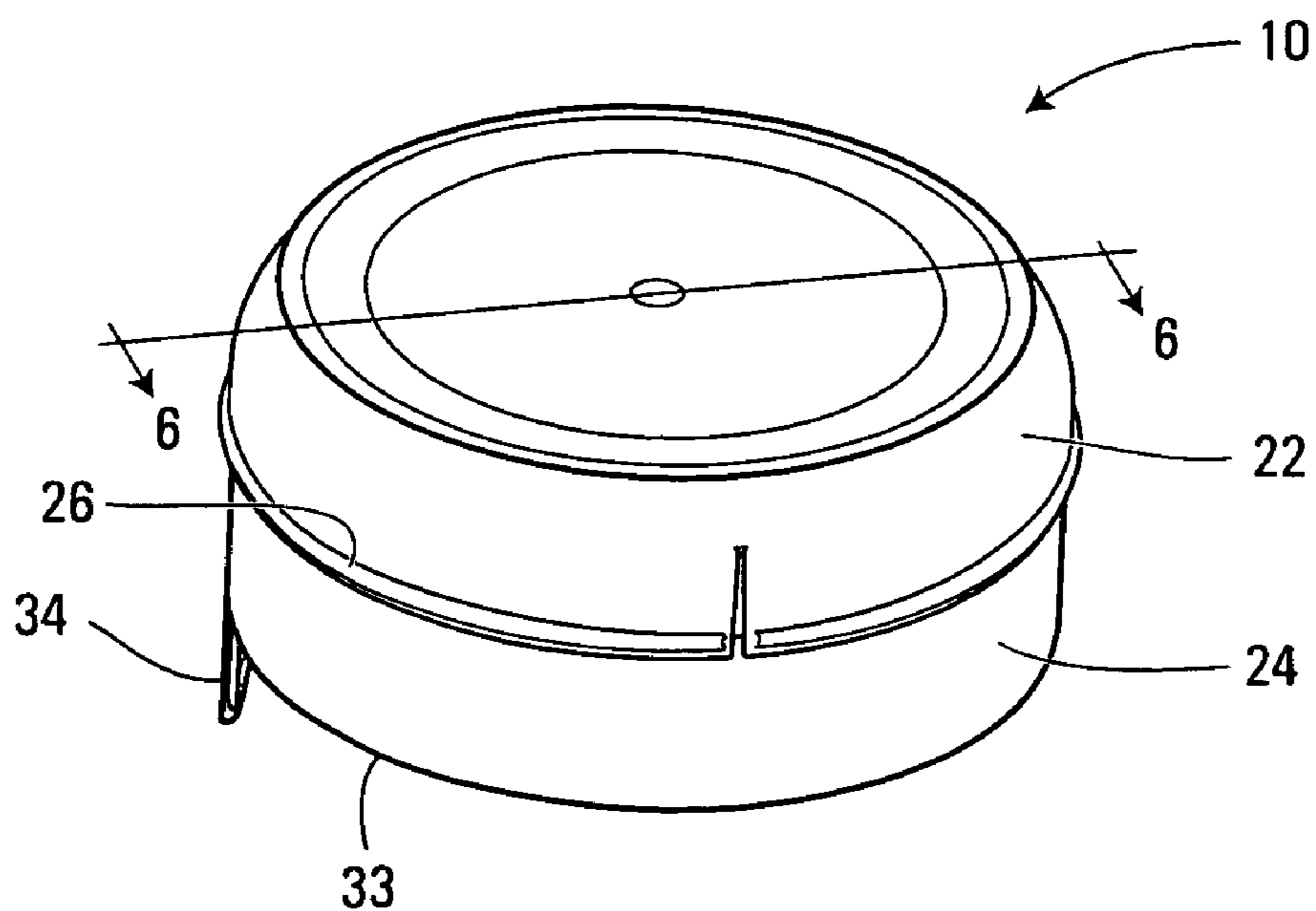
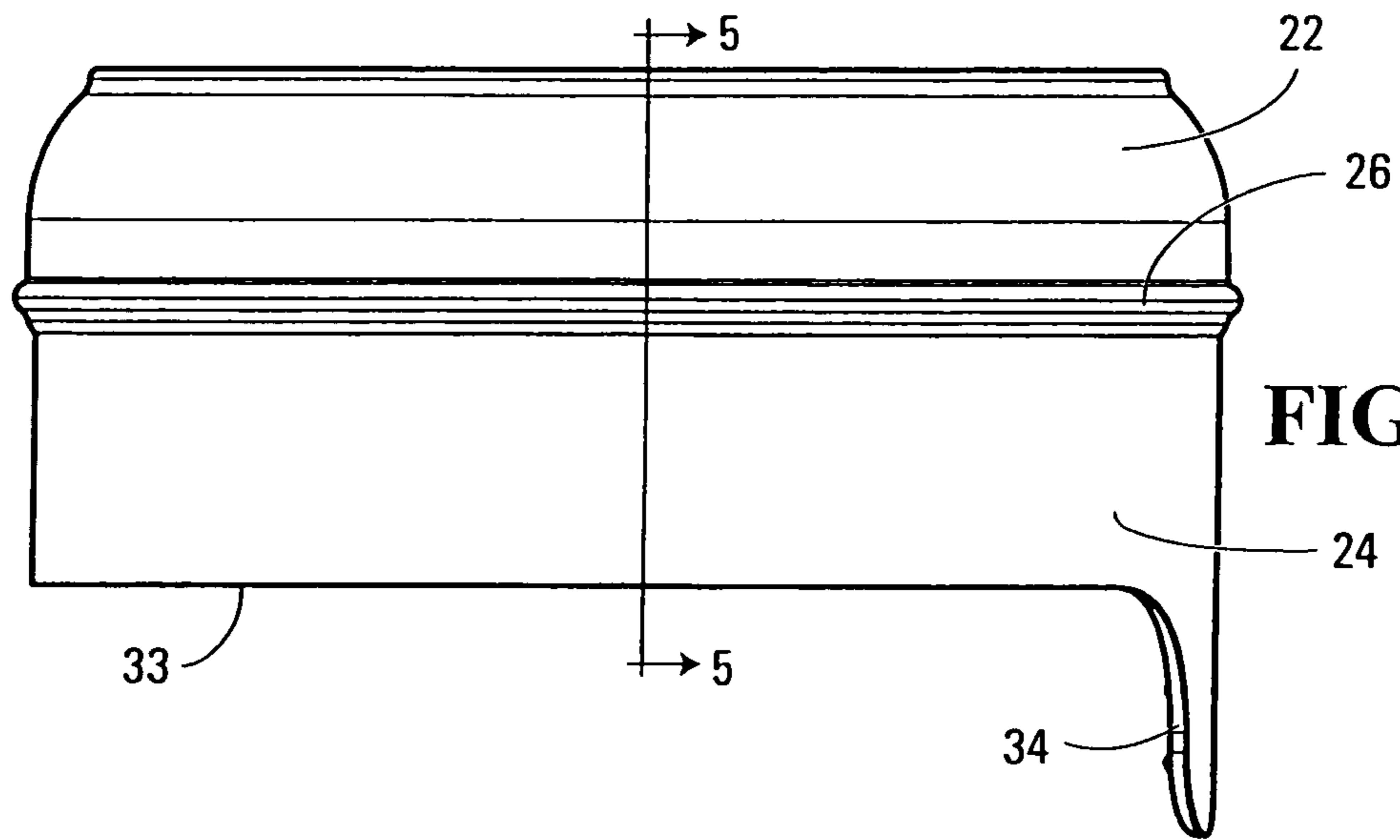
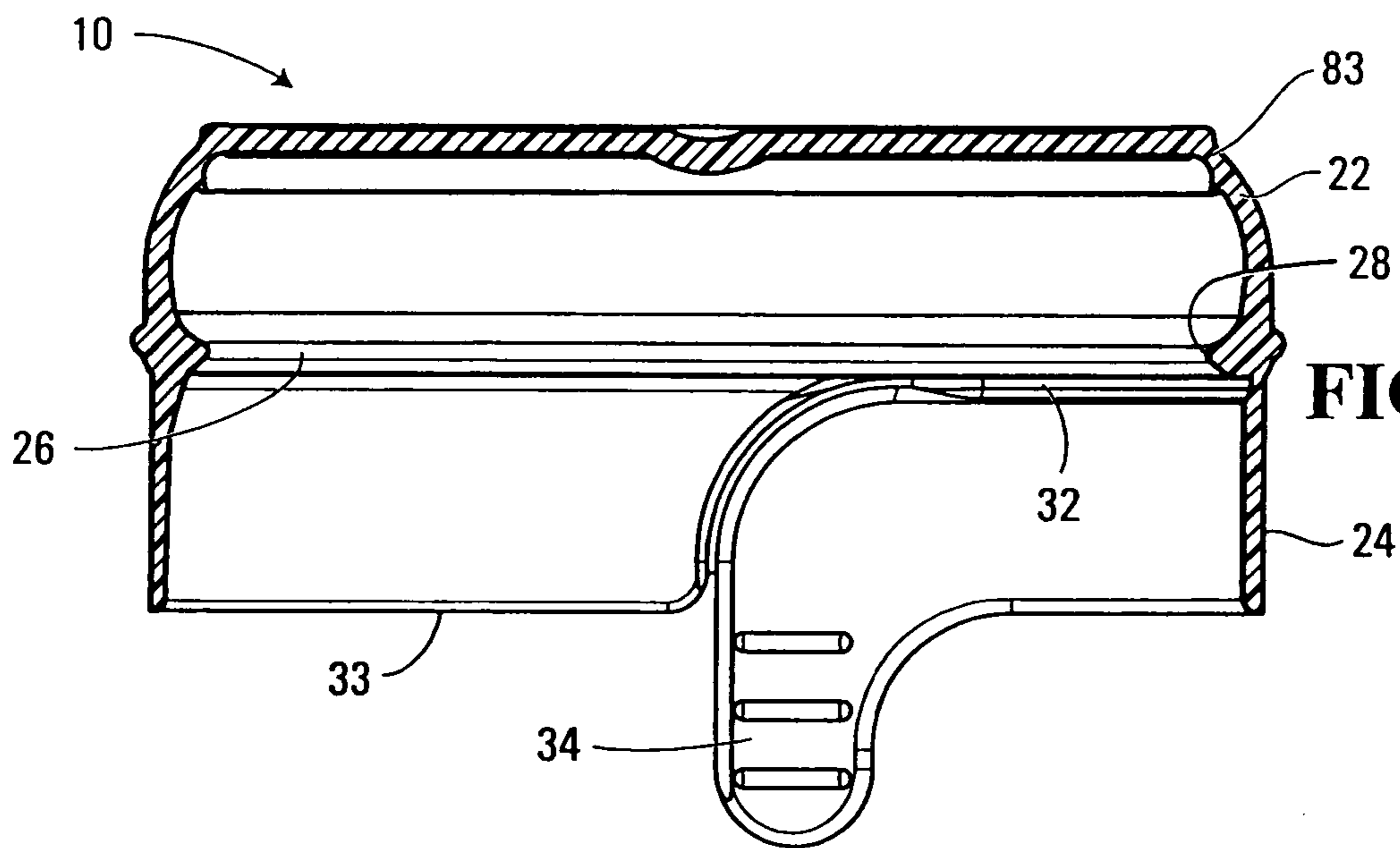

FIG. 3



**FIG. 4**



**FIG. 5**

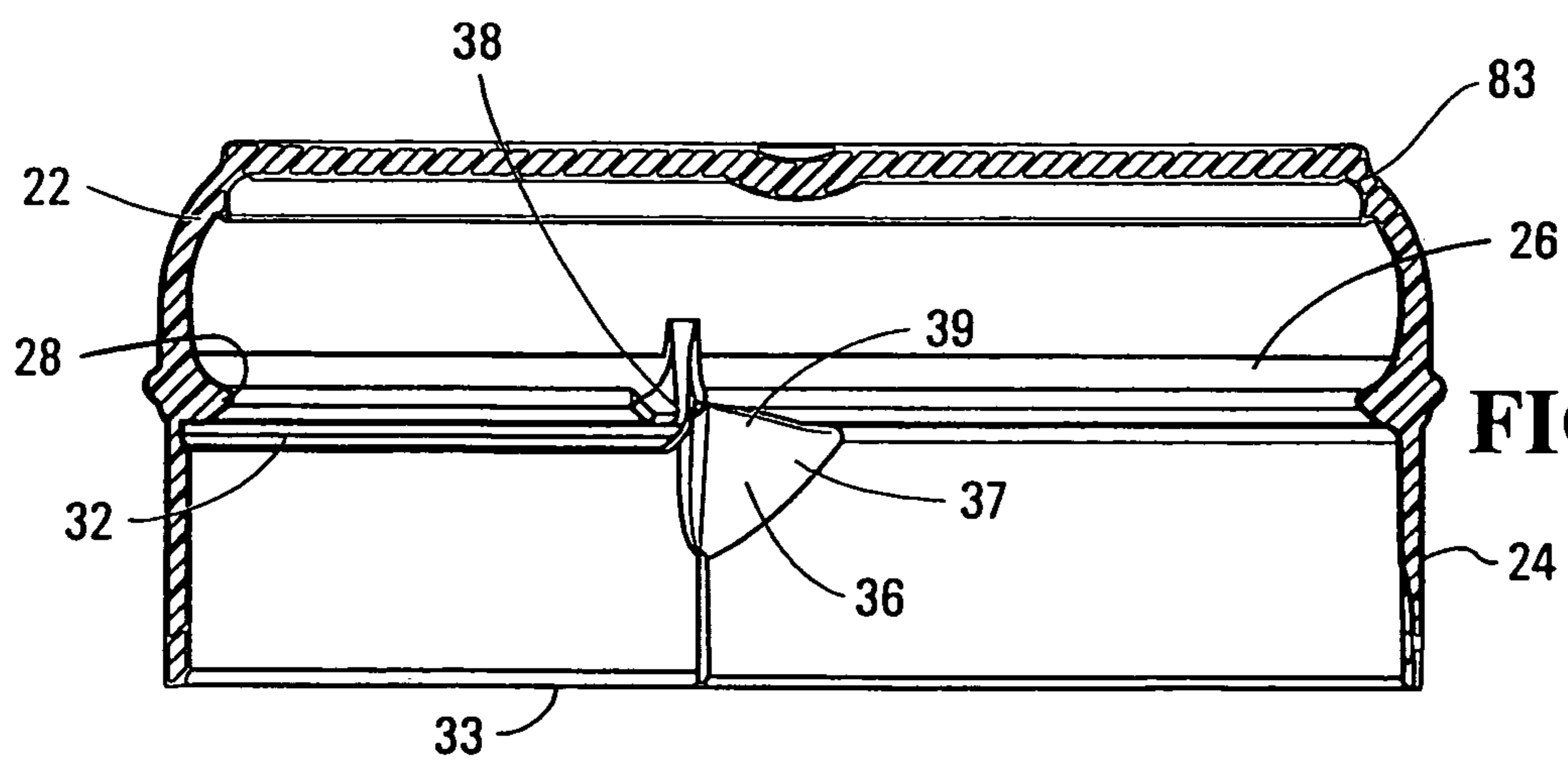

**FIG. 6**

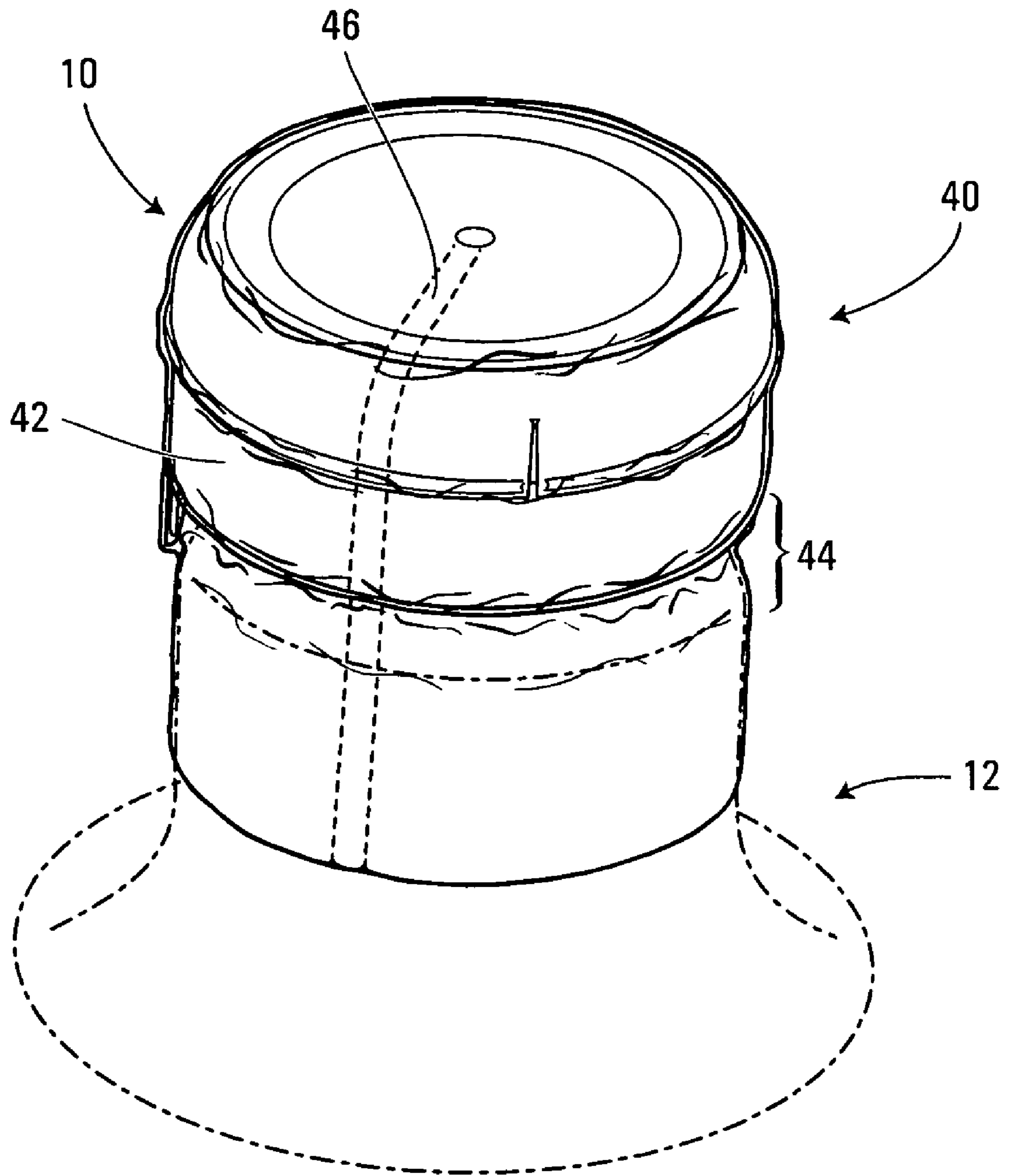

**FIG. 7**

1

## CAP AND CLOSURE SYSTEM FOR CLOSING A LARGE POTABLE LIQUID BOTTLE

### FIELD OF THE INVENTION

The present invention relates to a threadless cap for closing a potable liquid bottle, such as a water bottle for a water dispenser, and to a closure system including such a threadless cap.

### BACKGROUND OF THE INVENTION

A potable liquid bottle, such as a water bottle for a water cooler or similar dispenser, is usually provided with a cap to close and seal a discharge opening on the neck of the bottle during storage, transportation, and manipulation of the bottle. Of course, other than water, the potable liquid contained in the bottle can also be juice, soft drink, or any other type of drinkable liquid.

The cap prevents inadvertent spilling of liquid from the bottle and contamination of the liquid by exposure to the environment. The cap also ensures that hygienic conditions exist on surfaces of the neck of the bottle and around the discharge opening on which liquid flowing out of the bottle will come into direct contact with. Typically, the cap is made of a polymeric material and includes a tension ring or the like that provides a radial force for retaining the cap on the neck of the bottle. The cap also generally includes a line of weakness that facilitates tearing or rupturing of the cap material by a manual pull when the cap is to be removed from the bottle.

Frequently, however, a tear of the cap material propagating along the line of weakness propagates along the entire periphery of the cap, which causes a first portion of the cap on which the manual pull is applied to be completely detached from a second portion of the cap which remains fixed on the neck of the bottle. In other words, conventional caps do not include any means to prevent complete separation of the first portion of the cap on which the manual pull is applied from the second portion. It then becomes difficult to remove the second portion remaining on the neck of the bottle since there no longer is sufficient cap material to provide a grip to apply the manual pull. Moreover, the difficulty in removing the cap is compounded by the presence of the tension ring which usually remains on the cap as part of the second portion. In fact, even without the difficulty arising from complete separation of the first and second portions of the cap, conventional caps do not include any means to reduce the retaining force exerted by the tension ring on the neck of the bottle when the cap is to be removed from the bottle, which often creates unnecessary difficulty in removing the cap.

In addition, in order to complement the hygienic conditions ensured by the cap, a protective sheath, sleeve, or wrap made of a polymeric material is sometimes used to cover a portion of the neck of the bottle and the cap. The protective sheath typically covers the entire cap and a portion of the neck of the bottle below the cap, since these elements are the ones most frequently contacted during manipulation of the bottle.

Now, the neck of the bottle generally has an annular recessed area below the upper edge of the neck. However, the dimensions of a conventional cap are such that the cap extends beyond the lower limit of the annular recessed area of the neck. As a result, the protective sheath essentially conforms to the outer surface of the cap and is prevented from conforming to at least a portion of the annular recessed area of the neck. The resulting configuration of the protective sheath is such that there is a tendency for axial sliding of the protective sheath on the cap and on the portion of the neck of the

2

bottle below the cap during manipulation of the bottle. In turn, the axial sliding of the protective sheath can lead to an increase in the area of the neck of the bottle and the cap that is exposed to direct contact with human hands during manipulation of the bottle, which is detrimental to the hygienic conditions of the bottle.

While various solutions to the above problems have been proposed, none of these is satisfactory and thus there remains a need in the industry to provide a threadless cap for closing a potable liquid bottle that alleviates at least in part the problems associated with existing caps.

### SUMMARY OF THE INVENTION

In accordance with a first broad aspect, the invention provides a threadless cap for closing a potable liquid bottle. The potable liquid bottle has a neck with an upper edge defining a discharge opening. The threadless cap comprises a lid for overlying and sealingly engaging the upper edge of the neck. The lid includes a tension ring for retaining the cap on the neck of the bottle, the tension ring having an inwardly extending rib for engaging the neck of the bottle. The threadless cap also comprises a skirt depending from the lid, the skirt including a line of weakness facilitating a manual tear of the skirt. The threadless cap further comprises a tear stop at a location intersecting a line of tear propagating as a result of a manual pull applied on the skirt, the tear stop preventing the line of tear to propagate beyond the tear stop.

In accordance with a second broad aspect, the invention provides a threadless cap for closing a potable liquid bottle. The potable liquid bottle has a neck with an upper edge defining a discharge opening. The threadless cap comprises a lid for overlying and sealingly engaging the upper edge of the neck. The lid includes a tension ring for retaining the cap on the neck, the tension ring having an inwardly extending rib for engaging the neck of the bottle. The threadless cap also comprises a skirt depending from the lid, the skirt including a line of weakness facilitating a manual tear of the skirt. The line of weakness includes a portion extending across the tension ring to reduce a retaining force exerted by the tension ring on the neck of the bottle when a tear line propagating as a result of a manual pull applied on the skirt extends across the tension ring.

In accordance with a third broad aspect, the invention provides a closure system for a potable liquid bottle. The potable liquid bottle has a neck having an upper edge defining a discharge opening and an annular recessed area below the upper edge, the annular recessed area having an upper end portion and a lower end portion. The closure system comprises a threadless cap having a lid for overlying and sealingly engaging the upper edge. The threadless cap also has a skirt depending from the lid, the skirt having a lower edge. The skirt has dimensions such that when the cap sealingly engages the upper edge of the neck, at least a portion of the lower edge of the skirt is located between the upper end portion and the lower end portion of the annular recessed area. The closure system further comprises a protective sheath for application on the cap and on a portion of the neck of the bottle below the cap. The protective sheath is shrinkable to create a recessed zone within the annular recessed area adjacent the portion of the lower edge of the skirt located between the upper end portion and the lower end portion of the annular recessed area.

In accordance with a fourth broad aspect, the invention provides a water bottle comprising a neck having an upper edge defining a discharge opening and an annular recessed area on the neck below the upper edge, the annular recessed area having an upper edge portion and a lower edge portion.

3

The water bottle also has a threadless cap having a lid overlying and sealingly engaging the upper edge. The threadless cap also has a skirt depending from the lid, the skirt having a lower edge, at least a portion of the lower edge being located within the annular recessed area between the upper edge portion and the lower edge portion. The water bottle further comprises a protective sheath applied on the bottle, the protective sheath extending over the cap and over a portion of the neck located below the cap. The protective sheath forms a recessed zone overlying the annular recessed area and being adjacent to the portion of the lower edge of the skirt located within the annular recessed area between the upper edge portion and the lower edge portion.

In accordance with a fifth broad aspect, the invention provides a threadless cap for a water bottle having a neck with an upper edge defining a discharge opening, the neck also including an annular recessed area below the upper edge. The threadless cap comprises a lid for overlying and sealingly engaging the upper edge of the bottle. The lid includes a tension ring for retaining the cap on the neck of the bottle, the tension ring having an inwardly extending rib for engaging the neck of the bottle. The threadless cap also comprises a skirt depending from the lid, the skirt having a lower edge, a portion of the lower edge residing in the annular recessed area when the cap is applied on the bottle and the lid sealingly engages the upper edge of the bottle.

These and other aspects and features of the present invention will now become apparent to those of ordinary skill in the art upon review of the following description of specific embodiments of the invention in conjunction with the accompanying drawings.

#### BRIEF DESCRIPTION OF THE DRAWINGS

A detailed description of specific embodiments of the present invention is provided herein below, by way of example only, with reference to the accompanying drawings, in which:

FIG. 1A shows an isometric view of a threadless cap for closing a potable liquid bottle in accordance with a specific example of implementation of the present invention;

FIG. 1B shows an isometric view of the neck of the potable liquid bottle shown in FIG. 1A;

FIG. 2 shows an isometric view of the underside of the threadless cap shown in FIG. 1A;

FIG. 3 shows an isometric view of the threadless cap shown in FIG. 1A;

FIG. 4 shows an elevation view of the threadless cap shown in FIG. 3;

FIG. 5 shown a cross-sectional elevation view of the threadless cap along line 5-5 in FIG. 4;

FIG. 6 shown a cross-sectional elevation view of the threadless cap along line 6-6 in FIG. 3; and

FIG. 7 shows an isometric view of a closure system for a potable liquid bottle in accordance with a specific example of implementation of the present invention.

In the drawings, the embodiments of the invention are illustrated by way of examples. It is to be expressly understood that the description and drawings are only for the purpose of illustration and are an aid for understanding. They are not intended to be a definition of the limits of the invention.

#### DETAILED DESCRIPTION OF SPECIFIC EMBODIMENTS

FIG. 1A shows a threadless cap 10 for closing a potable liquid bottle 12 in accordance with a specific example of

4

implementation of the invention. In this application, threadless is intended to mean that the cap 10 does not have threads that are required to retain the cap 10 on the potable liquid bottle 12. The potable liquid contained in the bottle 12 can be water, juice, soft drink, or any other type of drinkable liquid. In the specific embodiments described in the present description, the potable liquid bottle 12 on which the cap 10 is to be mounted is a bottle for a water cooler or other liquid dispenser.

As can be seen in FIG. 1B, the potable liquid bottle 12 has a main body 14 defining a container (not shown) for holding liquid. The bottle 12 also has a neck 18 having an upper edge 27 defining a discharge opening 20 through which liquid contained in the container can be discharged, and an annular recessed area 19 below the upper edge 27. The annular recessed area 19, which extends around the perimeter of the neck 18, has an upper end portion 21 and a lower end portion 23. Upon installation of the bottle 12 in a dispenser device (not shown), actuation of the dispenser by a user causes liquid contained in container to flow through the discharge opening 20 into the dispenser and eventually through a faucet of the dispenser, where the liquid can be poured into a glass, cup, or the like.

Referring to FIGS. 1A and 1B and to FIGS. 2 to 6, the cap 10 comprises a lid 22 for overlying and sealingly engaging the upper edge 27 of the neck 18 of the bottle 12 and a skirt 24 depending from the lid 22. In the specific embodiment shown, the lid 22 and the skirt 24 are a unitary structure made of a polymeric material such as polyethylene. The lid 22 and the skirt 24 can be integrally formed, for instance, via an injection molding process. In other embodiments, the lid 22 and the skirt 24 are made of separate pieces and thereafter assembled together using, for instance, a gluing or sonic welding operation. Although not shown in the drawings, the lid 22 can be provided with a suitable gasket to better seal the upper edge 27.

The lid 22 includes a tension ring 26 for retaining the cap 10 on the neck 18 of the bottle 12. Upon positioning the cap 10 on the neck of the bottle 12, the tension ring 26 provides a radial force that causes the cap 10 to be retained on the neck 18. The tension ring 26 has an inwardly extending rib 28 for engaging the neck 18 of the bottle 12. The rib 28 is an internal projection or protrusion. In the non-limiting example of implementation shown, the rib 28 is in the form of a continuous projection extending along a substantial portion of the perimeter of the lid 22. In other embodiments, the rib 28 can be segmented, that is, the rib 28 can be formed of individual segments disposed along the periphery of the lid 22 rather than a continuous structure. Also, in this specific example of implementation, the tension ring 26 extends over substantially the entire periphery of the lid 22, although it is to be understood that the tension ring 26 can also be designed to extend along only a portion of the periphery of the lid 22. As well, while the lid 22 shown in FIGS. 1 to 6 is essentially a circular structure, it will be appreciated that various other configurations are possible without departing from the spirit of the invention.

In FIGS. 5 and 6, the cross-sectional view of the cap 10 shows that the thickness of the cap 10 in the shoulder area 83 is somewhat reduced by comparison to prior art caps in order to increase the flexibility of the cap 10 in that region. Accordingly, this allows the rib 28 to be made thicker and to project radially inwardly further such as to create a stronger retention force on the neck 18 of the bottle 12. When the cap 10 is applied on the neck 18 of the bottle 12, the tension ring is progressively spread radially until it snaps into place. The



increased flexibility of the shoulder area **83** allows the thicker retention ring to be conveniently applied on the neck **18** of the bottle **12**.

The skirt **24** depends from the lid **22** and surrounds the neck **18** of the bottle **12** when the cap **10** is installed thereon. In the particular embodiment shown, the skirt **24** has a lower edge **33** and is dimensioned such that when the cap **10** sealingly engages the upper edge of the neck **18**, at least a portion of the lower edge **33** of the skirt **24** is located between the upper end portion **21** and the lower end portion **23** of the annular recessed area **19** of the neck **18** of the bottle **12**.

The skirt **24** includes a line of weakness **32** facilitating a manual tear of the skirt **24**. The line of weakness **32** is a line along which the skirt material is likely to tear or rupture when the skirt **24** is pulled. In the non-limiting example of implementation shown in FIGS. **1** to **6**, the line of weakness **32** is realized by making the skirt material thinner along a certain line selected to be the line of weakness **32** than at other portions of the skirt **24**. Alternatively, the line of weakness **32** can be realized by making a series of indentations or a series of perforations in the skirt material along a certain line selected to be the line of weakness **32**. In the specific embodiment shown, the line of weakness **32** extends along a portion of the periphery of the skirt **24** in the vicinity of the tension ring **26**. More specifically, the line of weakness **32** extends along approximately three-quarters of the periphery of the skirt **24** in an area adjacent to the tension ring **26**. Furthermore, in this case, the line of weakness **32** includes a portion **38** extending across the tension ring **26**. When the skirt **24** is torn and the material is ruptured at the portion **38**, the tension ring **26** is severed which reduces its ability to hold the cap **10** on the bottle **12**.

In addition, in the non-limiting embodiment shown, the skirt **24** defines a pull tab **34** for facilitating a manual tear of the skirt material along the line of weakness **32** when the cap **10** is removed from the bottle **12**. The pull tab **34** projects down and depending on its size may extend down past the lower end portion **23** of the annular recessed area **19**.

In the particular example of implementation shown in FIGS. **1** to **6**, the cap **10** further comprises a tear stop **36** at a location intersecting a line of tear propagating as a result of a manual pull applied on the skirt **24**. The line of tear produced by a manual pull of the skirt **24** is most likely to follow the line of weakness **32** of the skirt **24**. The tear stop **36** prevents the line of tear to propagate beyond the tear stop **36**. More specifically, the tear stop **36** is a structure adapted to prevent propagation of the line of tear beyond the location of the structure. In the specific embodiment shown, the tear stop **36** includes a thickened portion on the cap **10**. More specifically, the tear stop **36** is realized by a thickening of the skirt material in a certain area of the skirt **24**. Thickening of the skirt material is intended to mean that the skirt material in that certain area of the skirt **24** is thicker than in adjacent areas of the skirt **24** through which the line of weakness **32** extends. Once the propagating line of tear reaches the tear stop **36**, the thicker material of the skirt **24** at that location will prevent further tearing of the skirt material without a significant increase in the pulling force applied on the skirt **24**. In other embodiments, the tear stop **36** can be realized by a separate piece of material affixed, for example, by gluing or sonic welding to a specific location of the cap **10**. In yet other embodiments, the tear stop **36** can be realized by forming a hole of sufficient dimensions in the skirt material. When the tear reaches such a tear stop **36**, the absence of material in the hole negates availability of material through which the tear can propagate and thus prevents further propagation of the tear beyond that location.

In the specific example of implementation, the tear stop **36** is located adjacent the rib **28** and as such assists the rib **28** in performing the function of a tension ring. The tear stop **36** has a cross-sectional shape that is analogous to the cross-sectional shape of the rib **28**. More specifically, the tear stop **36** has a smooth ramp surface **37** and allows the tension ring of the cap **10** to progressively spread radially outwardly as the cap is being snap fitted on the neck **18** of the bottle **12**. Above the ramp surface **37**, the tear stop **36** defines a tooth **39** that engages the neck **18** of the bottle **12** to assist the tension ring in retaining the cap on the neck **18** of the bottle **12**.

It will thus be appreciated that the tension ring **26**, the line of weakness **32**, and the tear stop **36** facilitate the mounting, retention, and removal of the cap **10** on or from the neck **18** of the bottle **12**. In particular, the tension ring **26** facilitates installation and ensures retention of the cap **10** on the neck **18** of the bottle **12**. For their part, the line of weakness **32** and the tear stop **36** facilitate the removal of the cap **10** from the neck **18** of the bottle **12**.

Specifically, when a user applies a pulling force on the pull tab **34** of the skirt **24**, a tear or rupture of the skirt material is initiated and propagates along the line of weakness **32** under continual application of the force. In the particular embodiment shown, the line of weakness **32** is configured such that a strip is formed when the skirt **24** is being torn. Upon reaching the tear stop **36**, the tear of the skirt material, or tear line, propagating along the line of weakness **32** is prevented from further propagation through the tear stop **36**. Advantageously, this prevents a situation whereby a tear line would propagate along the entire periphery of the skirt **24** causing for the skirt to be completely detached from the lid **22**, with the latter remaining fixed on the neck **18** of the bottle **12**. In other words, the tear stop **36** prevents complete separation of the strip formed from the torn skirt material from the remainder of the cap **10**. In addition, owing to the portion **38** of the line of weakness **32** extending across the tension ring **26** which, in this particular embodiment, is located adjacent the tear stop **36**, the tear line propagates along the portion **38** and thus tears or ruptures at least part of the tension ring **26**. As a result, the retaining force exerted by the tension ring **26** on the neck **18** of the bottle **12** is reduced thereby facilitating removal of the cap **10** from the neck **18**.

The cap **10** may also be part of a closure system for a potable liquid bottle. FIG. **7** shows a closure system **40** for a potable liquid bottle **12**, in accordance with a specific example of implementation of the invention. The bottle **12** is essentially identical to that described previously in connection with FIG. **1B**. The closure system **40** comprises a threadless cap **10**, such as the cap described previously in connection with FIGS. **1** to **6**, and a protective sheath **42** for application on the cap **10** and on a portion of the neck **18** of the bottle **12** below the cap **10**. The protective sheath **42** is shrinkable to create a recessed zone **44** within the annular recessed area **19** of the neck **18** adjacent the portion of the lower edge **33** of the skirt **24** located between the upper end portion **21** and the lower end portion **23** of the annular recessed area **19**.

In a particular example of implementation, the portion of the lower edge **33** of the skirt **24** that is located between the upper end portion **21** and the lower end portion **23** of the annular recessed area **19** includes the entirety of the lower edge **33** of the skirt **24** except the pull tab **34**. Also, the sheath **42** is heat shrinkable on the cap **10** and on the portion of the neck **18** of the bottle **12** below the cap **10**. Furthermore, like the skirt **24**, the sheath **42** includes a line of weakness **46** to facilitate tear and removal of the sheath **42** after the sheath has been heat shrunk on the cap **10** and on the portion of the neck **18** of the bottle **12** below the cap **10**. The line of weakness **46**

7

is realized by making the sheath material thinner along a certain line selected to be the line of weakness **46** than at other portions of the sheath **42**. Alternatively, the line of weakness **46** can be realized by making a series of indentations or a series of perforations in the sheath material along a certain line selected to be the line of weakness **46**.

Advantageously, the recessed zone **44** within the annular recessed area **19** of the neck **18** reduces the tendency of the sheath **42** to slide on the cap **10** and on the portion of the neck **18** of the bottle **12** below the cap **10**. Thus, the recessed zone **44**, which is made possible by the dimensions of the skirt **24** of the cap **10**, enhances retention of the sheath **42** on the cap **10** and on the portion of the neck **18** of the bottle **12** below the cap **10**. In addition, the rib **28** of the tension ring **26** projects radially outwardly out of the cap **10** which further enhances retention of the sheath **42**. The enhanced retention of the sheath **42** helps in ensuring that hygienic conditions are maintained in the area of the neck **18** of the bottle **12** and the cap **10** that is exposed to direct contact with human hands during manipulation of the bottle **12**.

Although the above description related to a specific type of cap, it will be appreciated that the invention can also be applied to caps having other features. For instance, the invention can be applied to a cap which has a lid portion that is pierced when a bottle on which the cap is mounted is installed in a liquid dispenser. The invention can also be applied to caps having a central well as described, for instance, in U.S. Pat. No. 6,032,812.

The above description of the embodiments should not be interpreted in a limiting manner since other variations, modifications and refinements are possible within the spirit and scope of the present invention. The scope of the invention is defined in the appended claims and their equivalents.

The invention claimed is:

**1.** A threadless cap for closing a potable liquid bottle, the potable liquid bottle having a neck with an upper edge defining a discharge opening, said threadless cap comprising:

a lid for overlying and sealing the discharge opening, said lid including a tension ring for retaining said cap on the neck of the bottle, said tension ring having an inwardly extending rib for engaging the neck of the bottle;

a skirt depending from said lid, said skirt including a line of weakness facilitating a manual tear of said skirt, said line of weakness extending along a portion of a perimeter of said skirt, said line of weakness including a portion extending across said tension ring to reduce a retaining force exerted by said tension ring on the neck of the bottle when a line of tear propagating as a result of a manual pull applied on said skirt extends across said tension ring, said line of weakness being configured such that the line of tear propagates along the portion of the perimeter of said skirt and then propagates along the portion extending across said tension ring; and

a tear stop for preventing the line of tear to propagate beyond said tear stop, said tear stop having a portion for engaging the neck of the bottle.

**2.** A threadless cap as defined in claim **1**, wherein said tear stop includes a thickened portion on said cap.

**3.** A threadless cap as defined in claim **1**, wherein said line of weakness is configured such that a strip is formed when said skirt is being torn.

**4.** A threadless cap as defined in claim **3**, wherein said tear stop prevents complete separation of said strip from a remainder of said cap.

**5.** A threadless cap as defined in claim **4**, wherein said skirt includes a pull tab that is attached to said strip.

8

**6.** A threadless cap as defined in claim **5**, wherein said strip extends partially around the perimeter of said skirt.

**7.** A threadless cap as defined in claim **1**, wherein the portion of the perimeter of said skirt along which extends said line of weakness is adjacent to said tension ring.

**8.** A threadless cap as defined in claim **7**, wherein said lid and said skirt are integrally formed.

**9.** A threadless cap as defined in claim **8**, wherein said lid and said skirt are integrally formed by injection molding.

**10.** A threadless cap for closing a potable liquid bottle, the potable liquid bottle having a neck with an upper edge defining a discharge opening, said threadless cap comprising:

a lid for overlying and sealing the discharge opening, said lid including a tension ring for retaining said cap on the neck of the bottle, said tension ring having an inwardly extending rib for engaging the neck of the bottle;

a skirt depending from said lid, said skirt including a line of weakness facilitating a manual tear of said skirt, said line of weakness extending along a portion of a perimeter of said skirt adjacent to said tension ring, said line of weakness including a portion extending across said tension ring to reduce a retaining force exerted by said tension ring on the neck of the bottle when a tear line propagating as a result of a manual pull applied on said skirt extends across said tension ring, said line of weakness being configured such that the tear line propagates along the portion of the perimeter of said skirt and then propagates along the portion extending across said tension ring, said line of weakness being configured such that a strip is formed when said skirt is being torn; and

a tear stop for preventing the tear line to propagate beyond said tear stop, said tear stop having a portion for engaging the neck of the bottle.

**11.** A threadless cap as defined in claim **10**, wherein said tear stop includes a thickened portion on said cap.

**12.** A threadless cap as defined in claim **11**, wherein said tear stop prevents complete separation of said strip from a remainder of said cap.

**13.** A threadless cap as defined in claim **12**, wherein said skirt includes a pull tab that is attached to said strip.

**14.** A threadless cap as defined in claim **13**, wherein said strip extends partially around the perimeter of said skirt.

**15.** A threadless cap as defined in claim **10**, wherein the portion of the perimeter of said skirt along which extends said line of weakness is below and adjacent to said tension ring.

**16.** A threadless cap as defined in claim **15**, wherein said lid and said skirt are integrally formed.

**17.** A threadless cap as defined in claim **16**, wherein said lid and said skirt are integrally formed by injection molding.

**18.** A threadless cap as defined in claim **1**, wherein the portion of the perimeter of said skirt comprises at least half of the perimeter of said skirt.

**19.** A threadless cap as defined in claim **1**, wherein the portion of the perimeter of said skirt comprises at least three-quarters of the perimeter of said skirt.

**20.** A threadless cap as defined in claim **1**, wherein the portion of said line of weakness extending across said tension ring is adjacent to said tear stop.

**21.** A threadless cap as defined in claim **1**, wherein said tear stop has a surface allowing said tension ring to progressively spread radially outwardly when said cap is being snap fitted on the neck of the bottle.

**22.** A threadless cap as defined in claim **10**, wherein the portion of the perimeter of said skirt comprises at least half of the perimeter of said skirt.

9

23. A threadless cap as defined in claim 10, wherein the portion of the perimeter of said skirt comprises at least three-quarters of the perimeter of said skirt.

24. A threadless cap as defined in claim 10, wherein the portion of said line of weakness extending across said tension ring is adjacent to said tear stop.

25. A threadless cap as defined in claim 10, wherein said tear stop has a surface allowing said tension ring to progressively spread radially outwardly when said cap is being snapped fitted on the neck of the bottle.

26. A threadless cap for closing a water bottle, the water bottle having a neck with an upper edge defining a discharge opening, said threadless cap comprising:

a lid for overlying and sealing the discharge opening, said lid including a tension ring for retaining said cap on the neck of the bottle, said tension ring having an inwardly extending rib for engaging the neck of the bottle; and a skirt depending from said lid, said skirt including:

a first weakness line segment below and adjacent to said tension ring and extending along said tension ring for at least half of a perimeter of said tension ring;

a second weakness line segment extending across said tension ring;

a pull tab to initiate a tear which propagates along said first weakness line segment in order to partially separate said skirt from said lid and then along said second weakness line segment to rupture said tension ring and allow removal of said cap from the neck; and

10

a tear stop for preventing the tear to propagate beyond said tear stop, said tear stop having a portion for engaging the neck of the water bottle.

27. A threadless cap as defined in claim 26, wherein said first weakness line segment and said second weakness line segment are part of a continuous line of weakness.

28. A threadless cap as defined in claim 27, wherein said continuous line of weakness is configured to prevent a complete separation of said skirt from said lid as said cap is being removed from the neck.

29. A threadless cap as defined in claim 28, wherein said first weakness line segment extends along said tension ring over more than half of the perimeter of said tension ring.

30. A threadless cap as defined in claim 29, wherein said first weakness line segment defines an arc of circle.

31. A threadless cap as defined in claim 30, wherein said arc of circle is parallel to said tension ring.

32. A threadless cap as defined in claim 30, wherein said second weakness line segment extends upwardly from said first weakness line segment and intersects said tension ring.

33. A threadless cap as defined in claim 28, wherein said first weakness line segment extends along said tension ring over less than three-quarters of the perimeter of said tension ring.

34. A threadless cap as defined in claim 1, wherein said inwardly extending rib tapers radially inwardly.

\* \* \* \* \*