



US007578268B2

(12) **United States Patent**
Chrisman et al.

(10) **Patent No.:** **US 7,578,268 B2**
(45) **Date of Patent:** **Aug. 25, 2009**

(54) **AIR INTAKE PORTING FOR A TWO STROKE ENGINE**

(75) Inventors: **Bruce M. Chrisman**, Oklahoma City, OK (US); **Randy Coleman**, Oklahoma City, OK (US)

(73) Assignee: **Cameron International Corporation**, Houston, TX (US)

(*) Notice: Subject to any disclaimer, the term of this patent is extended or adjusted under 35 U.S.C. 154(b) by 45 days.

2,768,616 A *	10/1956	Venediger	123/51 BD
3,257,998 A	6/1966	Brooks	
3,797,467 A	3/1974	Tenney	
4,000,723 A *	1/1977	Boyesen	123/73 AA
4,066,050 A *	1/1978	Ford-Dunn	123/73 SP
4,135,479 A	1/1979	Reitz et al.	
4,202,299 A *	5/1980	Boyesen	123/73 A
4,352,343 A *	10/1982	Batoni	123/51 BA
4,383,503 A *	5/1983	Griffiths	123/73 PP
4,809,648 A	3/1989	Luo	
6,662,765 B2 *	12/2003	Araki	123/73 A
7,255,072 B2 *	8/2007	Yamaguchi	123/73 AA
7,258,087 B1 *	8/2007	Chrisman et al.	123/74 R
2003/0075124 A1 *	4/2003	Haman	123/73 PP

(21) Appl. No.: **11/779,004**

(22) Filed: **Jul. 17, 2007**

(65) **Prior Publication Data**

US 2008/0011261 A1 Jan. 17, 2008

Related U.S. Application Data

(63) Continuation of application No. 11/367,136, filed on Mar. 3, 2006, now Pat. No. 7,258,087.

(51) **Int. Cl.**
F02B 25/00 (2006.01)

(52) **U.S. Cl.** **123/73 PP**; 123/73 FA;
123/74 AP

(58) **Field of Classification Search** 123/73 PP,
123/74 R, 193.6, 193.4, 73 AA, 73 FA, 74 AP
See application file for complete search history.

(56) **References Cited**

U.S. PATENT DOCUMENTS

2,639,699 A * 5/1953 Kiekhaefer 123/73 V

* cited by examiner

Primary Examiner—Hai H Huynh

(74) *Attorney, Agent, or Firm*—Fletcher Yoder

(57) **ABSTRACT**

A two stroke engine of a particular configuration can have its power output increased by running bigger pistons and using ports in the piston skirt through which to conduct compressed air within the skirt through short passages in the cylinder housing that conduct the air from within the skirt to above the piston. As a result a larger piston can be used for the same spacing and opening size in the block to save the need to redesign the block and the crankshaft. A position adjuster for the piston moves it axially without rotation of the piston ports out of alignment with inlet ports in the housing. The piston rod is held in the crosshead using a flat to prevent rotation while an adjuster nut that is turned creates axial movement in the piston rod with a lock nut securing the final piston position.

25 Claims, 6 Drawing Sheets

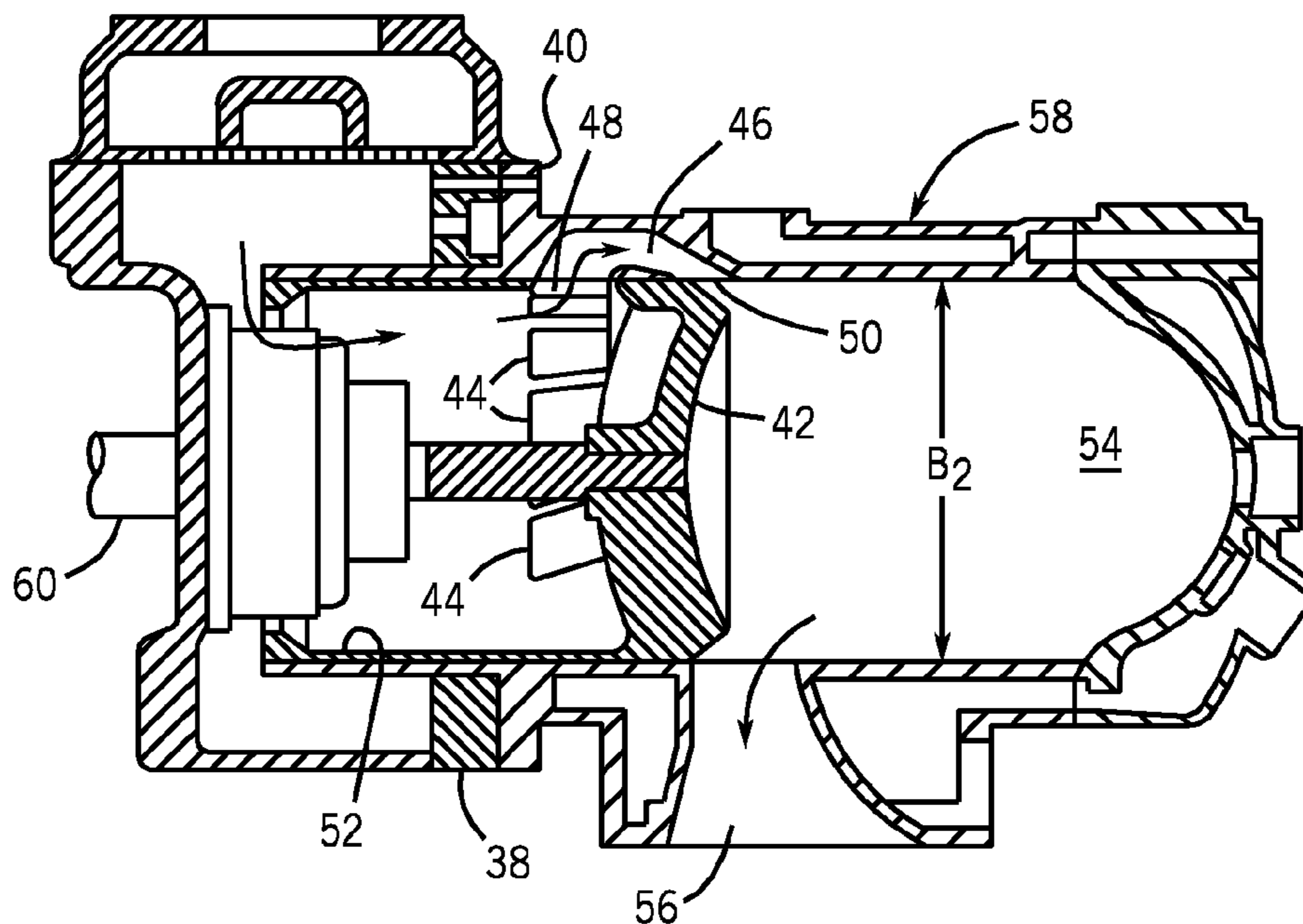

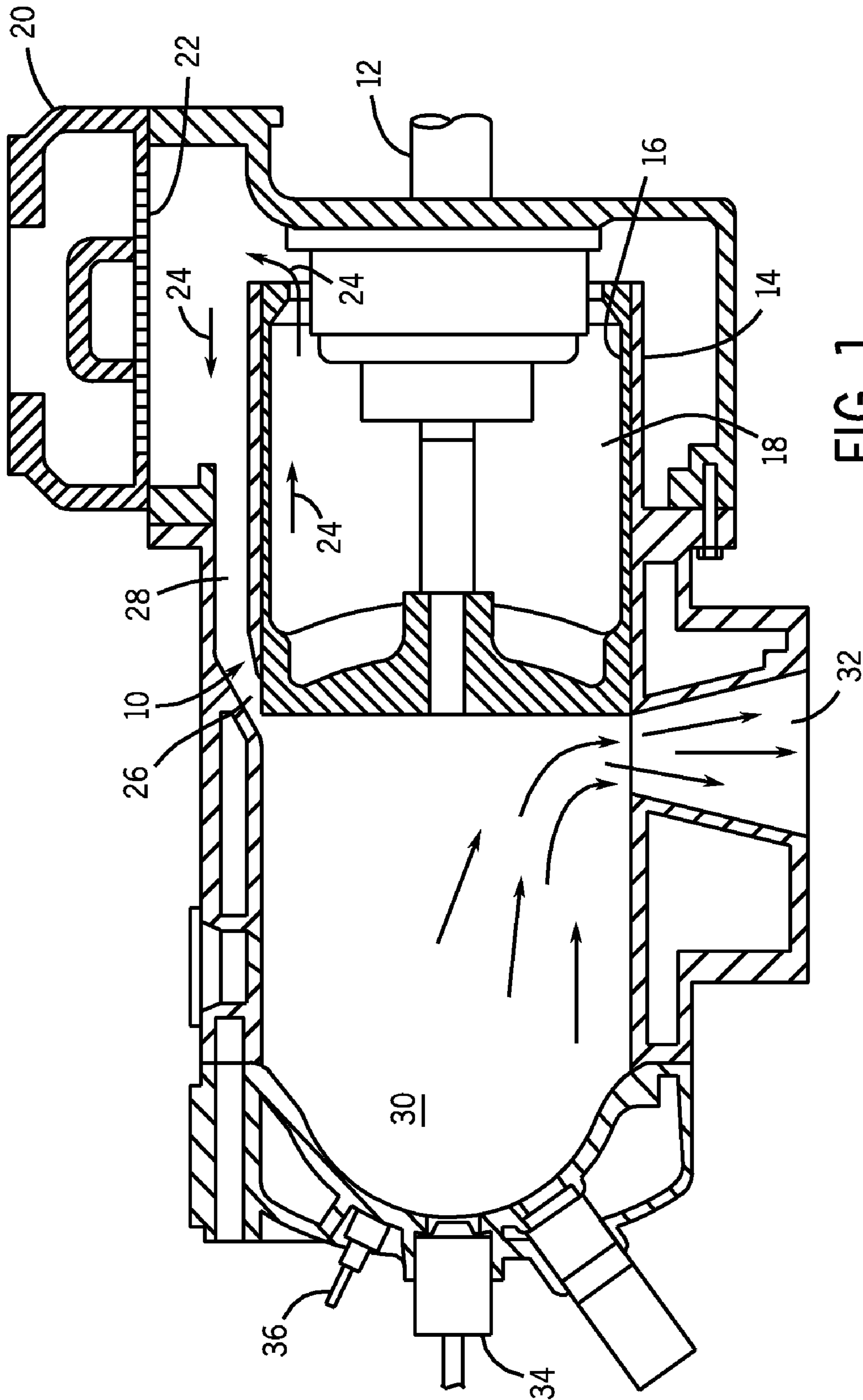

FIG. 1
(PRIOR ART)

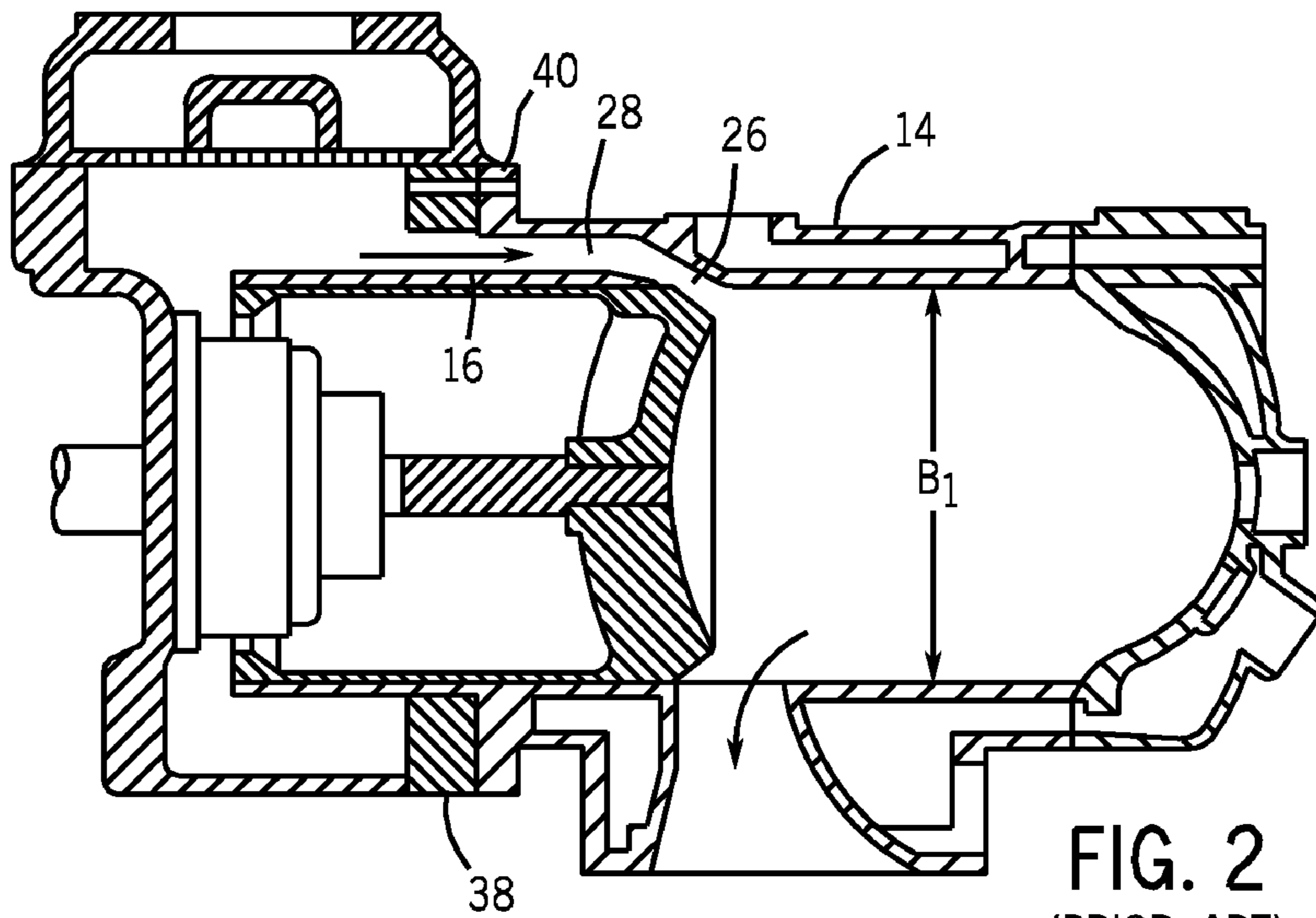

FIG. 2
(PRIOR ART)

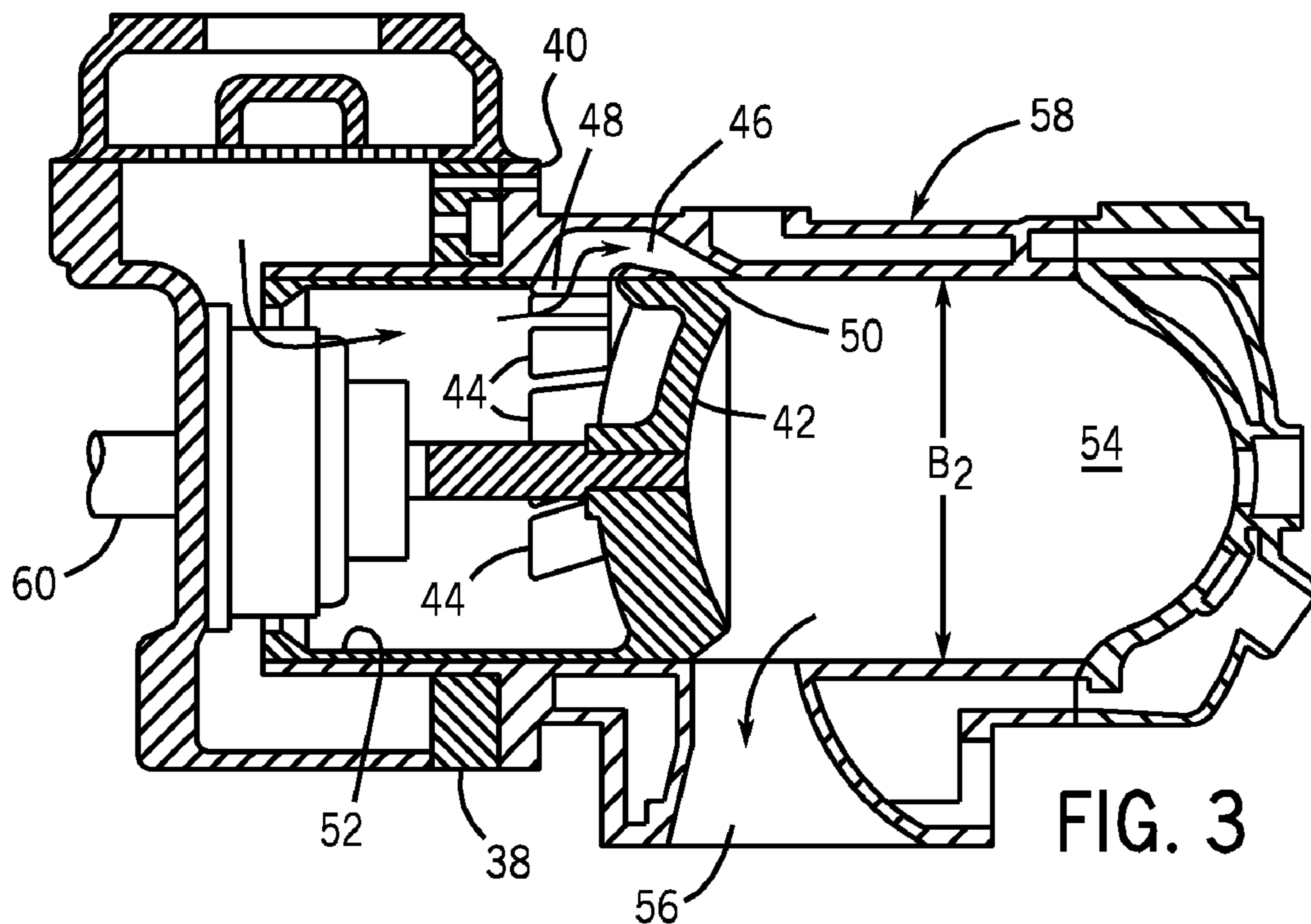

FIG. 3

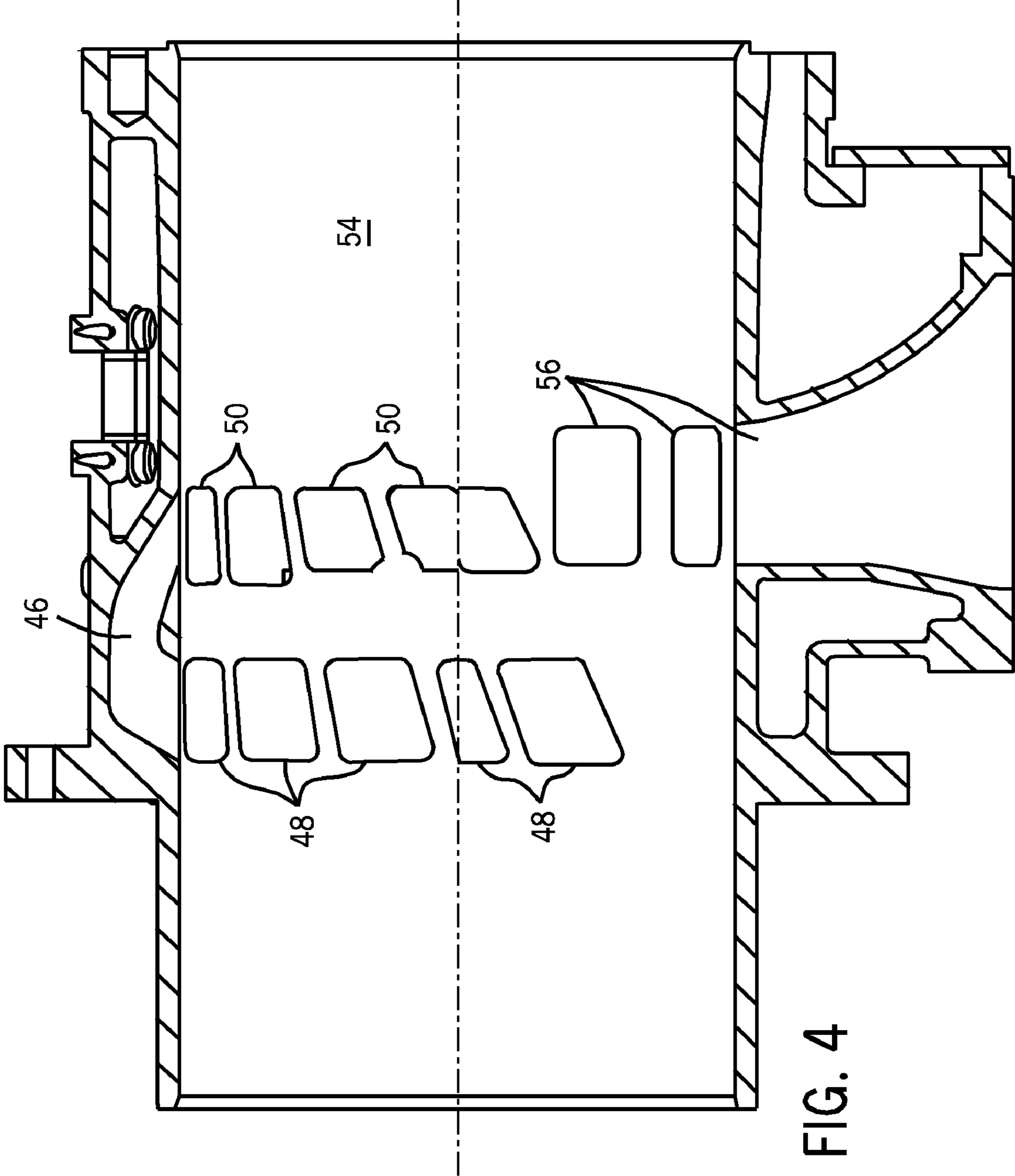

FIG. 4

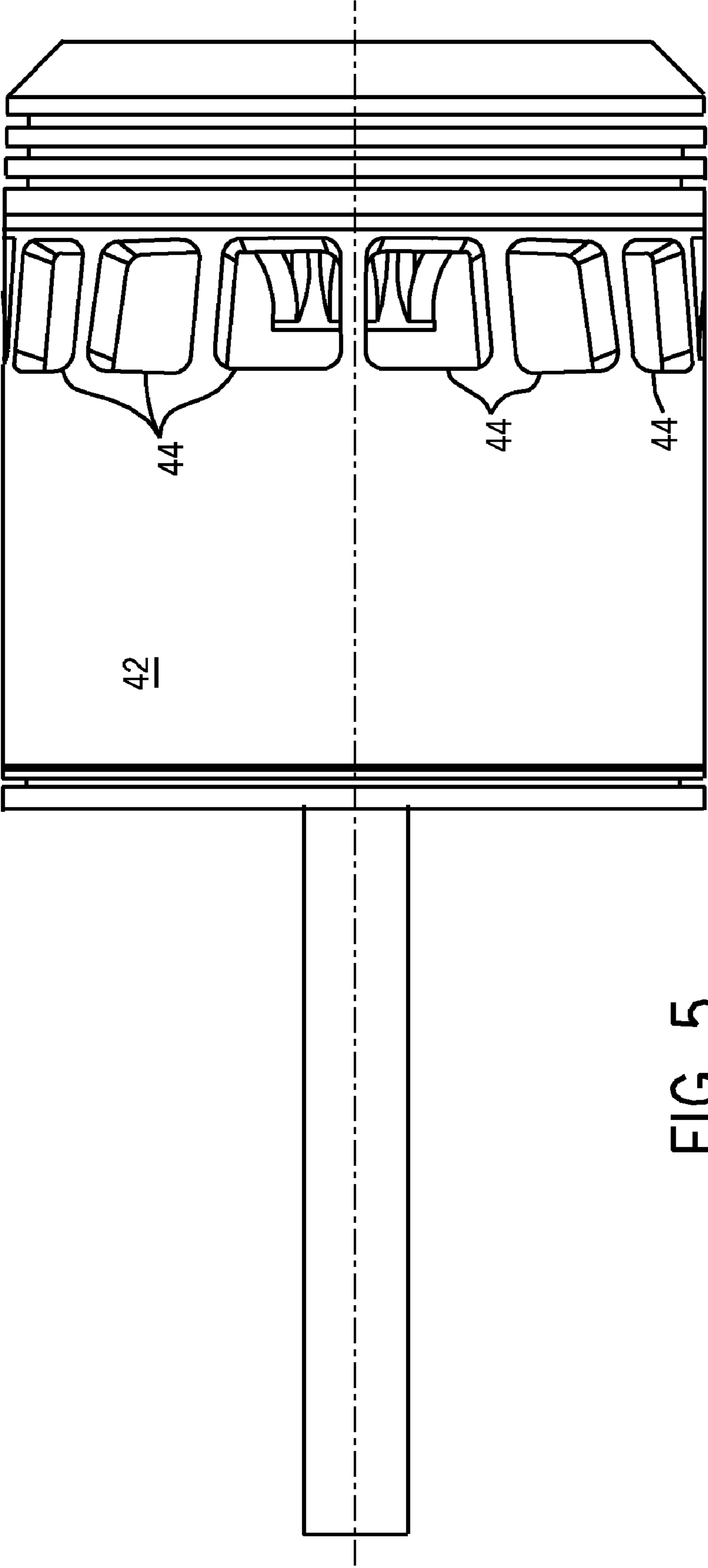

FIG. 5

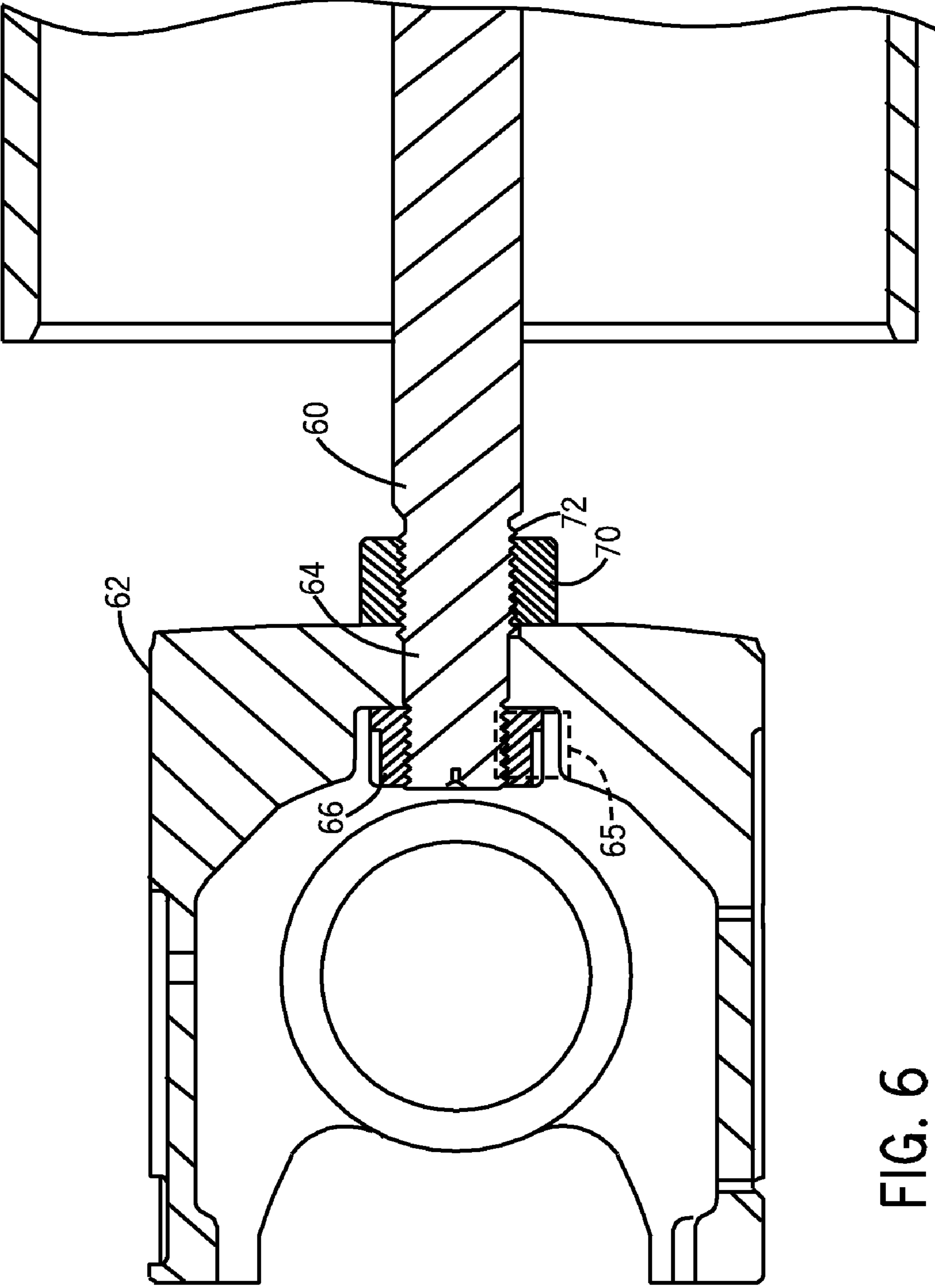

FIG. 6

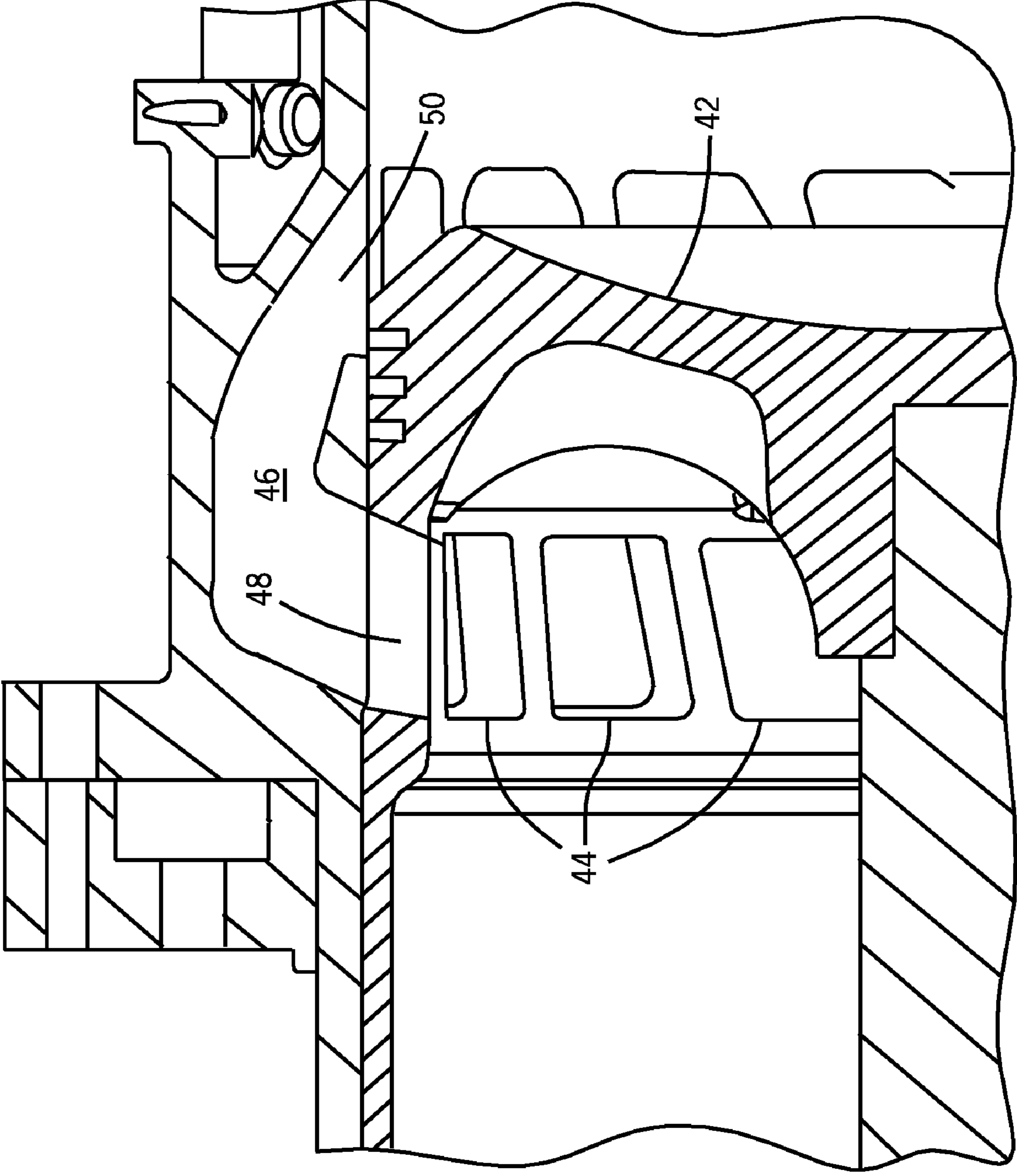

FIG. 7

1

AIR INTAKE PORTING FOR A TWO STROKE
ENGINECROSS REFERENCE TO RELATED
APPLICATION

This application is a continuation of U.S. patent application Ser. No. 11/367,136, filed on Mar. 3, 2006 now U.S. Pat. No. 7,258,087, which is hereby incorporated by reference.

BACKGROUND

The field of this invention is two stroke engines and, more particularly, relates to an air intake porting configuration that allows an increased cylinder bore and facilitates a corresponding power increase for a given exterior cylinder dimension.

In an effort to get more power out of a given frame size for a two stroke engine, one readily apparent way is to simply increase the bore of the cylinders. As a result, the power output increases by the square of the ratio of the new bore divided by the previous bore. The problem with doing this is that the throws on the crankshaft have given spacing, and the enlargement of the bore forces an increase in external dimensions of the cylinder. The existing block may also define limits to any desired increase of the bore, depending on the available spacing between the existing bores, for instance. The problem with expanding the bore size of two stroke engines is that air intake passages to the cylinder require a fair amount of space, because of their location. In the past, air was introduced through passages extending from the crank end of the power cylinder to the intersection of the intake ports with the main bore of the cylinder. Another way was to build an air chest into the engine block around the intake ports for the cylinder. However this method would substantially increase the size of the engine block, which increases the weight of the engine and may not be compatible with the given engine bay, for instance.

While a wholly new engine could be designed, such a process can be expensive and time consuming. It is clearly desirable if the bore size can be increased without major changes to the basic engine structure. In accordance with certain embodiments, the present invention provides methods and apparatus to increase the bore sizes of a given engine design without significant changes to the frame or crankshaft. The invention is put into perspective by a quick review of two stroke engine basics, shown in FIG. 1, and a comparison of the intake porting of a known design with that of the present invention shown in a comparison of FIGS. 2 and 3.

Referring to FIG. 1, a piston 10 having a rod 12 is disposed in a cylinder housing 14. The piston 10 also has a skirt 16 that defines a volume 18 around the rod 12. An inlet valve housing 20 includes a reed valve 22 that operates like a check valve. In the view of FIG. 1, the piston 10 is descending after a power stroke. Air that previously was drawn into housing 20 and past reed valve 22 is forced out of volume 18 as shown by arrows 24. That air that had been compressed under the skirt during the decision from the power stroke can, after the piston descends enough to expose the inlet ports 26, exit from under the skirt 16 to a passage 28 in the cylinder housing 14. The release of the pressurized air through passage 28 and through ports 26 scavenges out the remaining exhaust gasses in the cylinder 30 to exit through the exposed exhaust ports 32. After this happens, the piston 10 rises to close off intake ports 26 and exhaust ports 32. At that point, gas is injected through the gas injection valve 34, and the spark plug 36 ignites the mixture when the piston has nearly reached top dead center.

2

Again the upward movement of the piston while the ports 26 and 32 are closed by the piston opens the reed valve 22 to allow more air to get sucked in. The cycles just described simply repeat as the engine operates.

FIG. 2 is similar to FIG. 1 and is placed on the same sheet as FIG. 3 to allow for an easy comparison of the differences therebetween. Referring first to FIG. 2, it can be seen that the presence of passage 28 leading to ports 26 along the outside of skirt 16 directly defines the size of the surrounding cylinder housing 14. In a given engine, any increase in the bore size B_1 necessarily increases the size of the cylinder housing 14 and necessitates a redesign of the crank and engine frame, for example. These and other aspects of the present invention will be more apparent to those skilled in the art from a review of the description of the preferred embodiment and the associated drawings and the claims which define the full scope of the invention.

SUMMARY OF THE INVENTION

As will be described below, the present invention, in accordance with certain embodiments, reconfigures the intake air routing to make use of the space formerly occupied by passage 28 to accommodate a bigger piston so that the cylinder housing 14 will fit on the same connection to the block 38. This is made possible by routing the air inlet through the piston skirt, as will be explained below. As will also be explained below, the position adjustment mechanism for the piston will also be explained. This mechanism adjusts the piston position axially without need to rotate the piston.

In accordance with certain embodiments, a two stroke engine of a particular configuration can have its power output increased via a larger cylinder bore and by using ports in the piston skirt through which to conduct compressed air within the skirt through short passages in the cylinder housing that conduct the air from within the skirt to above the piston. As a result, a larger piston can be used for the same spacing and opening size in the block, reducing the need to redesign the block and the crankshaft, for instance. A position adjuster for the piston moves it axially without rotation of the piston ports out of alignment with inlet ports in the housing. The piston rod is held in the crosshead using a flat to prevent rotation while an adjuster nut that is turned creates axial movement in the piston rod with a lock nut securing the final piston position.

BRIEF DESCRIPTION OF THE DRAWINGS

These and other features, aspects, and advantages of the present invention will become better understood when the following detailed description is read with reference to the accompanying drawings in which like characters represent like parts throughout the drawings, wherein:

FIG. 1 is a section view of a known design for a two stroke engine showing a single cylinder;

FIG. 2 is another section view of the cylinder of FIG. 1;

FIG. 3 is a section view of the ported piston design of the invention in accordance with an embodiment of the present invention;

FIG. 4 is a perspective view of a cylinder bore showing the inlet air passages with the lower row being the one that eventually aligns with the ports in the piston skirt;

FIG. 5 is a perspective view of the piston showing the ports in the skirt;

FIG. 6 illustrates the connection of the piston rod to the crosshead and shows the axial adjustment mechanism for the piston; and

FIG. 7 is a detailed view of the piston ports aligned with the inlet passages in the cylinder assembly.

DETAILED DESCRIPTION

Referring to exemplary embodiment of the present invention illustrated in FIG. 3, the cylinder diameter B_2 is larger than the diameter B_1 yet the cylinder base 40 mounts to the same block connection 38 shown in both FIGS. 2 and 3. The reason a bigger piston 42 can be used is that the passage 28 from the FIG. 2 design has been eliminated in favor of a series of ports 44 arranged circumferentially at preferably a common axial elevation on the piston 42. The space formerly taken up by the passage 28 leading to outlets 32 in the prior design of FIG. 2 has been used to house a larger diameter piston 42. The cylinder housing 58 has reconfigured porting. It now features a generally C-shaped passage 46 having inlet ports 48 and outlet ports 50. When the ports 44 in the piston 42 come into alignment with inlets 48 of passage 46, the air that has already been pressurized within the skirt 52 on the down stroke of the piston 42 in what can be referred to as the lower zone can now escape into the cylinder volume 54 that can also be referred to as the compression zone. As this intake air enters this compression zone, it displaces (scavenges) the remaining exhaust gases from volume 54 out the exhaust ports 56. FIG. 4 shows some of the inlets 48 and their associated outlets 50 that are axially above in the cylinder 54. The outlets 50 have their shape optimized to best displace the residual exhaust gasses from the cylinder 54. As illustrated, the ports 48 and 50 are circumferentially offset from the exhaust ports 56. FIG. 5 gives a better view of the exemplary piston 42 with ports 44 at a common axial height and disposed circumferentially in a pattern that occupies, as presently illustrated, at least half the circumference. In the exemplary embodiment, the dimensions of ports 44 match the dimensions of inlets 48 on the passage 46 in the cylinder housing 58. Alignment of these ports is shown in FIG. 7. These pairs of openings should be maintained in a circumferential alignment to maximize the compressed air flow and the transfer of energy in the cylinder 54 after movement of piston 42 brings ports 44 up into alignment with inlets 48 in the housing 58.

It is beneficial if the piston position adjustment is able to move the piston 42 axially without rotating it, so as not to misalign circumferentially openings 44 in the skirt 52 with inlets 48 on cylinder housing 58. As shown in FIGS. 3 and 6, the piston rod extends partially through the crosshead 62 that is connected to the crankshaft (not shown) in a known manner. The extension of the rod 60 through the crosshead 62 is through an opening with a flat to match the flat 64 on rod 62. Rod 60 is allowed to move axially but not rotate when the adjusting nut 66 is turned through access hole 65. A lock nut 70 sits on threads 72 on rod 60. The minimum distance between the piston crown and the cylinder head, as illustrated, is adjustable to set the proper compression ratio for the engine. When the desired adjustment for the final position of piston 42 at top dead center is reached to get the desired clearance, the lock nut 70 is turned on threads 72 against the crosshead 62. Turning the adjuster nut 66 forces the rod 60 to move axially since flat 64 on rod 60 constrains rotation.

Those skilled in the art will appreciate that the elimination of the air intake passage outside the piston skirt has allowed the piston to take up that space to increase its size for a given opening in the block. For that reason the block and crank don't need to be redesigned and a given engine frame and crank can accommodate a bigger piston to increase the power output. The larger piston now directs the compressed air from within its skirt through skirt openings. As the piston rises the

skirt openings come up to align with the openings 48 in passages 46 in the cylinder housing 58. The compressed air passes from below piston 42 to above it. The difference in the designs is that the porting of the air through the skirt 52 allows the piston 42 to occupy space formerly used for air passages 28. As a result, the larger piston 42 can be accommodated in the same mount on an existing block. Additional power output is possible from a known engine block and crankshaft combination. Thus assuming the remaining components can deal with the additional power produced the need for a total redesign to get more power is avoided. What results is the ability to increase piston size to the size of the opening in the block by eliminating air passages outside the skirt and taking advantage of the volume within the skirt to hold the compressed air and deliver it at the proper time when ports are in alignment.

The adjuster mechanism allows axial adjustment of the piston 42 without rotating it so that ports 44 stay in circumferential alignment with inlets 48 while the needed clearance is obtained to set the proper compression ratio with the piston at top dead center.

The above description is illustrative of the preferred embodiment and many modifications may be made by those skilled in the art without departing from the invention whose scope is to be determined from the literal and equivalent scope of the claims below.

Again, the above description is illustrative of exemplary embodiments, and many modifications may be made by those skilled in the art without departing from the invention whose scope is to be determined from the literal and equivalent scope of the claims below.

The invention claimed is:

1. A system, comprising:

a piston comprising:

a head; and

a skirt extending from the head, wherein the skirt comprises a port;

a rod coupled to the piston; and

a feature configured to maintain an angular orientation of the port relative to a cylinder, wherein the rod does not rotate relative to the piston.

2. The system of claim 1, comprising a plurality of the ports spaced along a common circumference of the skirt.

3. The system of claim 1, comprising a cylinder configured to receive the piston.

4. The system of claim 3, wherein the cylinder comprises a passage having a separate inlet and outlet in an interior surface of the cylinder, and the port in the skirt is configured to align with the inlet in the interior surface of the cylinder to enable fluid flow around the head through the passage to the outlet.

5. The system of claim 4, comprising a plurality of the ports and a plurality of the passages, wherein the plurality of passages is equal to the plurality of ports.

6. The system of claim 1, wherein the feature comprises a first flat surface on a side of the rod.

7. The system of claim 6, comprising a crosshead configured to connect the piston to a crankshaft, wherein the crosshead comprises an opening configured to receive the rod, and the opening comprises a second flat surface corresponding to the first flat surface of the rod.

8. A system, comprising:

a piston comprising:

a head;

a skirt; and

a first plurality of passages through the skin, wherein the first plurality of passages is configured to enable flow through the skirt and around the head via a second

5

plurality of passages into and separately out of a cylinder, wherein the first and second plurality of passages are disposed about at least half of a circumference of the piston.

9. The system of claim 8, comprising the cylinder.

10. A system, comprising:

a cylinder configured to receive a piston, the cylinder comprising:

a wall;

a cylindrical bore defining an interior surface of the cylinder, wherein the interior surface defines a piston path;

a passage in the wall, wherein the passage has an inlet and a separate outlet on the interior surface of the cylinder; and

an air intake into the cylindrical bore, wherein the air intake is separate from the piston path.

11. The system of claim 10, wherein the passage is substantially aligned with a longitudinal axis of the cylinder.

12. The system of claim 10, comprising a plurality of passages each having the inlet and the outlet.

13. The system of claim 12, wherein the plurality of inlets are arranged along a generally common circumference of the interior surface.

14. The system of claim 12, wherein the plurality of outlets are arranged along a generally common circumference of the interior surface.

15. The system of claim 10, comprising an exhaust port extending from the interior surface through the wall to an exterior of the cylinder.

16. The system of claim 15, wherein the outlet and the exhaust port are arranged along a generally common circumference of the interior surface.

17. The system of claim 15, wherein the exhaust port is displaced circumferentially from the passage.

18. The system of claim 10, comprising a piston configured to operate within the cylinder, wherein a skirt of the piston comprises a port.

19. The system of claim 18, wherein alignment of the port in the skirt with the inlet in the wall is configured to enable

6

fluid flow through the passage into a compression zone defined by the piston and the cylinder.

20. The system of claim 18, comprising a feature configured to prevent rotational movement of the piston with respect to the cylinder.

21. A method, comprising:

translating a rod to actuate a piston disposed in a cylinder, wherein the piston defines a combustion zone and a lower zone in the cylinder; and

displacing a first volume of fluid from the lower zone to the combustion zone through a port in a skirt of the piston and a passage in a wall of the cylinder, wherein the passage is configured such that an outlet of the passage is disposed in the combustion zone when the port in the skirt is aligned with an inlet of the passage.

22. The method of claim 21, comprising:

actuating the piston toward the combustion zone such that the first volume of fluid in the combustion zone is compressed and a second volume of fluid is drawn into the lower zone;

igniting the first volume of fluid in the combustion zone; and

actuating the piston toward the lower zone such that exhaust from the first volume of fluid is expelled from the combustion zone through an exhaust port.

23. The method of claim 21, wherein actuating the piston comprises displacing the piston in an axial direction and not in a rotational direction.

24. A method, comprising:

providing a piston having a head, a skirt, and a rod, and an axial adjuster, wherein the skirt comprises a port, and the axial adjuster is configured to adjust an axial position of the head and the skirt relative to the rod without rotation between the rod and the head and skirt; and

providing a cylinder configured to receive the piston, wherein the cylinder comprises a channel on an interior surface of the cylinder to communicate with the port.

25. The method of claim 24, comprising providing an exhaust passage from the interior surface of the cylinder to an exterior of the cylinder.

* * * * *