



US007570982B2

(12) **United States Patent**
Fuimaono et al.

(10) **Patent No.:** **US 7,570,982 B2**
(45) **Date of Patent:** ***Aug. 4, 2009**

(54) **CATHETER HAVING MAPPING ASSEMBLY**

(75) Inventors: **Kristine B. Fuimaono**, Covina, CA (US); **Michel Haissaguerra**, Talence (FR)

(73) Assignee: **Biosense Webster, Inc.**, Diamond Bar, CA (US)

(*) Notice: Subject to any disclaimer, the term of this patent is extended or adjusted under 35 U.S.C. 154(b) by 0 days.

This patent is subject to a terminal disclaimer.

(21) Appl. No.: **11/582,623**

(22) Filed: **Oct. 17, 2006**

(65) **Prior Publication Data**

US 2007/0038055 A1 Feb. 15, 2007

Related U.S. Application Data

(60) Continuation of application No. 10/749,888, filed on Dec. 31, 2003, now Pat. No. 7,123,951, which is a continuation of application No. 10/075,803, filed on Feb. 11, 2002, now Pat. No. 6,804,545, which is a division of application No. 09/551,467, filed on Apr. 17, 2000, now Pat. No. 6,628,976.

(60) Provisional application No. 60/178,478, filed on Jan. 27, 2000.

(51) **Int. Cl.**
A61B 5/042 (2006.01)

(52) **U.S. Cl.** **600/374**; 600/381; 606/41; 607/122

(58) **Field of Classification Search** 600/374, 600/381; 606/41, 49; 607/122

See application file for complete search history.

(56) **References Cited**

U.S. PATENT DOCUMENTS

4,203,430 A	5/1980	Takahashi
4,207,873 A	6/1980	Kruey
4,777,955 A	10/1988	Brayton et al.
4,882,777 A	11/1989	Narula
4,920,980 A	5/1990	Jackowski

(Continued)

FOREIGN PATENT DOCUMENTS

EP 0 499 491 8/1992

(Continued)

OTHER PUBLICATIONS

M. Haissaguerra et al. "Spontaneous Initiation of Atrial Fibrillation by Ectopic Beats Originating in the Pulmonary Veins", *The New England Journal of Medicine*, 339:659-666 Sep. 3, 1998.

(Continued)

Primary Examiner—Lee S Cohen

(74) *Attorney, Agent, or Firm*—Christie, Parker & Hale, LLP

(57) **ABSTRACT**

A mapping catheter comprises a catheter body and a mapping assembly. The catheter body has an outer wall, proximal and distal ends, and at least one lumen extending therethrough. The mapping assembly comprises a generally straight proximal region attached to the catheter body, a generally circular main region distal the proximal region having an outer circumference, and a generally straight distal region distal the main region. The mapping assembly also comprises a support member having shape-memory, a non-conductive covering over the support member, and a plurality of electrodes on the non-conductive covering along the generally circular main region.

17 Claims, 5 Drawing Sheets

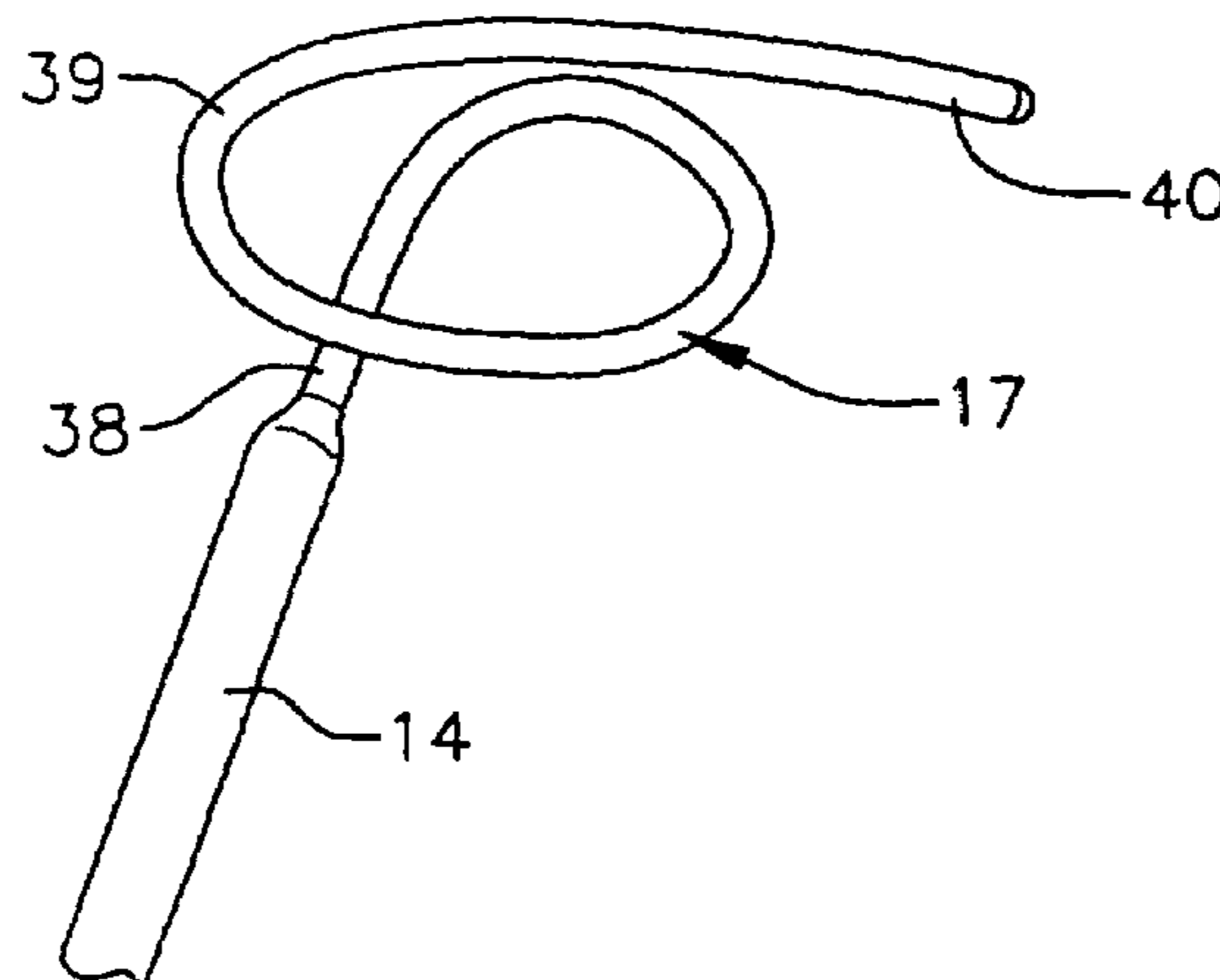

U.S. PATENT DOCUMENTS

4,960,134 A 10/1990 Webster, Jr.
 4,984,581 A 1/1991 Stice
 5,170,787 A 12/1992 Lindegren
 5,255,679 A 10/1993 Imran
 5,263,493 A 11/1993 Avitall
 5,275,162 A 1/1994 Edwards et al.
 5,327,905 A 7/1994 Avitall
 5,354,297 A 10/1994 Avitall
 5,383,923 A 1/1995 Webster, Jr.
 5,445,148 A 8/1995 Jaraczewski et al.
 5,456,664 A 10/1995 Heinzelman et al.
 5,462,544 A 10/1995 Saksena et al.
 5,487,385 A 1/1996 Avitall
 5,545,200 A 8/1996 West et al.
 5,549,581 A 8/1996 Lurie et al.
 5,582,609 A 12/1996 Swanson et al.
 5,617,854 A 4/1997 Munsif
 5,626,136 A 5/1997 Webster, Jr.
 5,642,736 A 7/1997 Avitall
 5,656,030 A 8/1997 Hunjan et al.
 5,673,695 A 10/1997 McGee et al.
 5,680,860 A 10/1997 Imran
 5,730,127 A 3/1998 Avitall
 5,755,760 A 5/1998 Maguire et al.
 5,797,905 A 8/1998 Fleischman et al.
 5,800,428 A 9/1998 Nelson et al.
 5,823,955 A 10/1998 Kuck et al.
 5,827,278 A 10/1998 Webster, Jr.
 5,836,947 A 11/1998 Fleischman et al.
 5,860,920 A 1/1999 McGee et al.
 5,865,800 A 2/1999 Mirarchi et al.
 5,879,295 A 3/1999 Li et al.
 5,882,333 A 3/1999 Schaer et al.
 5,882,346 A 3/1999 Pomeranz et al.
 5,931,811 A 8/1999 Haissaguerre et al.
 5,935,102 A 8/1999 Bowden et al.
 5,938,694 A 8/1999 Jaraczewski et al.
 5,951,471 A 9/1999 de la Rama et al.
 5,984,909 A 11/1999 Lurie et al.
 5,997,526 A 12/1999 Giba et al.
 6,002,955 A 12/1999 Willems et al.
 6,035,224 A 3/2000 West
 6,064,902 A 5/2000 Haissaguerre et al.
 6,088,614 A 7/2000 Swanson

6,090,104 A 7/2000 Webster, Jr.
 6,096,036 A 8/2000 Bowe et al.
 6,106,522 A 8/2000 Fleischman et al.
 6,120,476 A 9/2000 Fung et al.
 6,123,699 A 9/2000 Webster, Jr.
 6,129,724 A 10/2000 Fleischman et al.
 6,141,576 A 10/2000 Littmann et al.
 6,146,381 A 11/2000 Bowe et al.
 6,169,916 B1 1/2001 West
 6,171,277 B1 1/2001 Ponzi
 6,183,463 B1 2/2001 Webster, Jr.
 6,219,582 B1 4/2001 Hofstad et al.
 6,325,797 B1 12/2001 Stewart et al.
 6,468,260 B1 10/2002 Bumbalough et al.
 6,542,781 B1 4/2003 Koblish et al.
 6,628,976 B1 9/2003 Fuimaono et al.
 6,711,428 B2 3/2004 Fuimaono et al.
 6,795,721 B2 9/2004 Coleman et al.
 6,804,545 B2 10/2004 Fuimaono et al.
 6,845,257 B2 1/2005 Fuimaono et al.
 6,987,996 B2 1/2006 Fuimaono et al.
 7,123,951 B2* 10/2006 Fuimaono et al. 600/374
 2003/0191380 A1 10/2003 Fuimaono et al.
 2003/0199746 A1 10/2003 Fuimaono et al.
 2004/0143175 A1 7/2004 Coleman et al.
 2004/0158139 A1 8/2004 Fuimaono et al.

FOREIGN PATENT DOCUMENTS

EP 0 499 491 A2 9/1992
 EP 0 928 601 A1 7/1999
 EP 0928 601 A1 7/1999
 EP 0 985 423 3/2000
 EP 0 985 423 A2 3/2000
 EP 1 050 316 B1 12/2003
 EP 1050316 12/2003
 WO WO 95/10225 4/1995
 WO WO 95-10225 4/1995

OTHER PUBLICATIONS

Haissaguerre, M. et al., "Spontaneous Initiation of Atrial Fibrillation by Ectopic Beats Originating in the Pulmonary Veins," *The New England Journal of Medicine*, 339:659-666, Sep. 3, 1998, pp. 659-666, indicating relevance of listed references in this IDS.

* cited by examiner

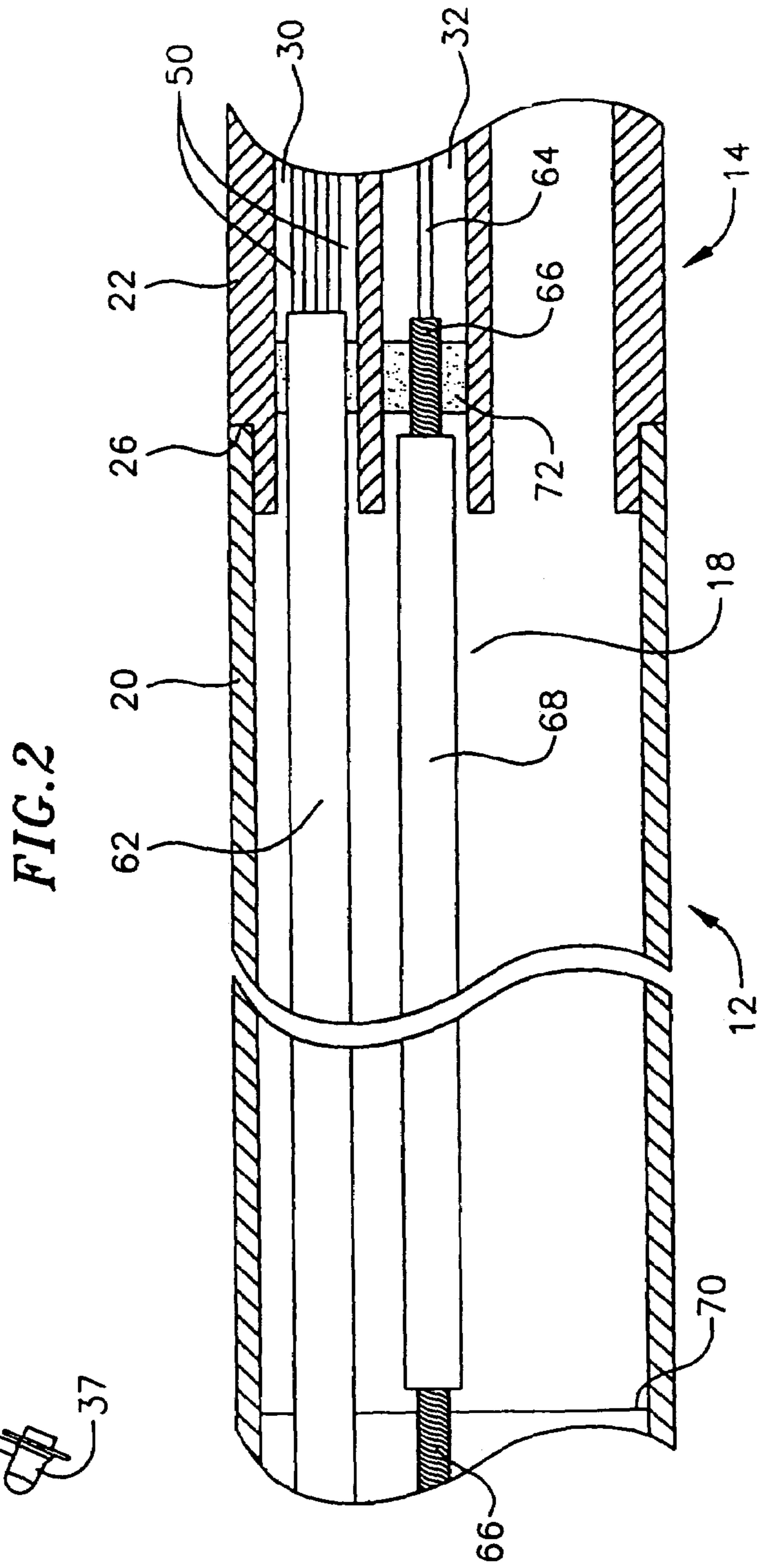
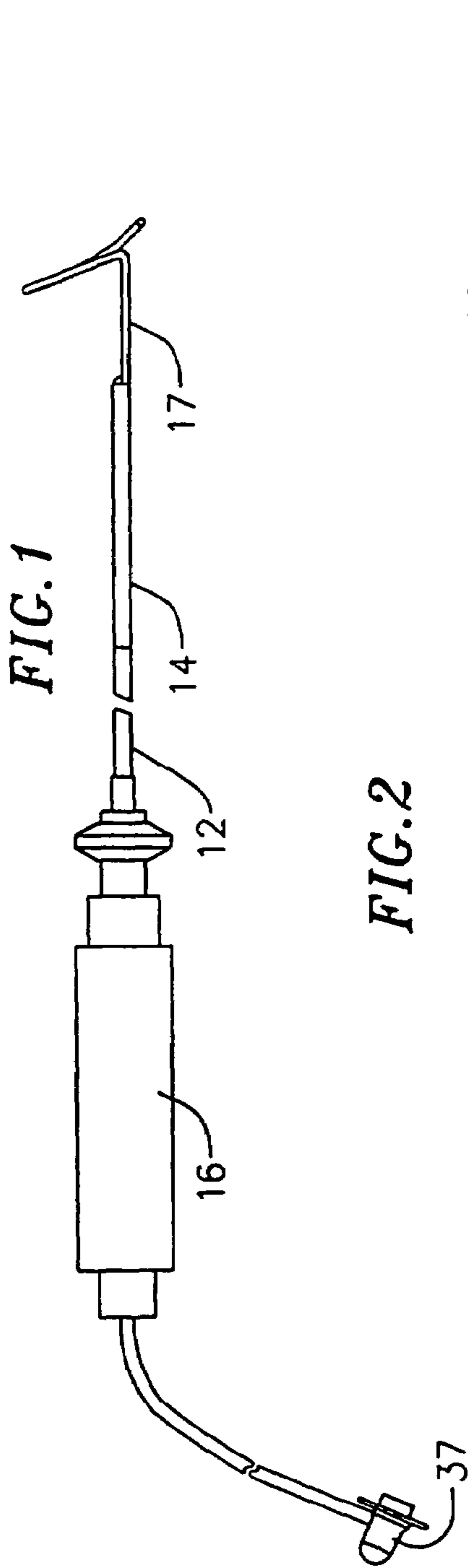
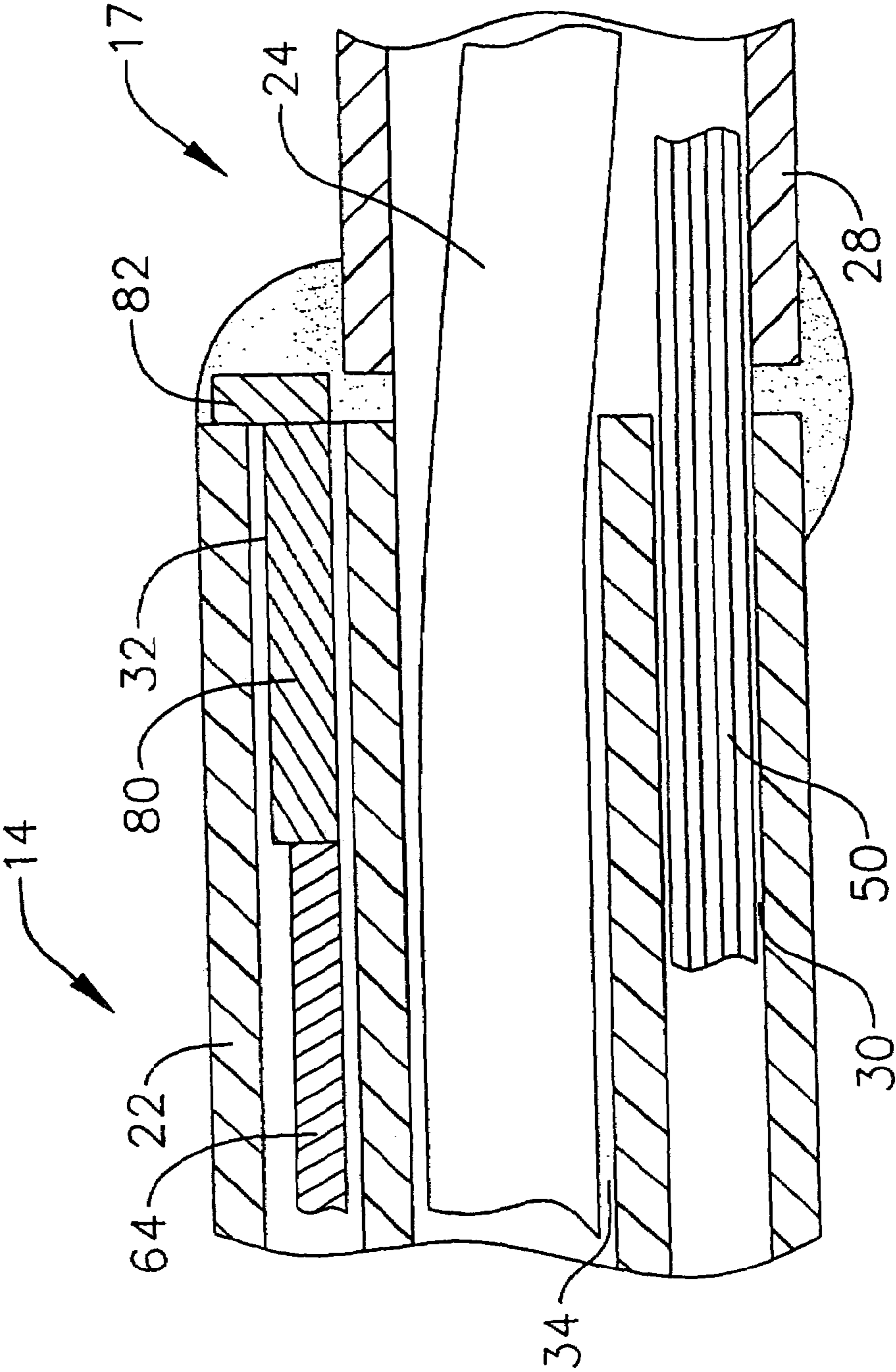

FIG. 3



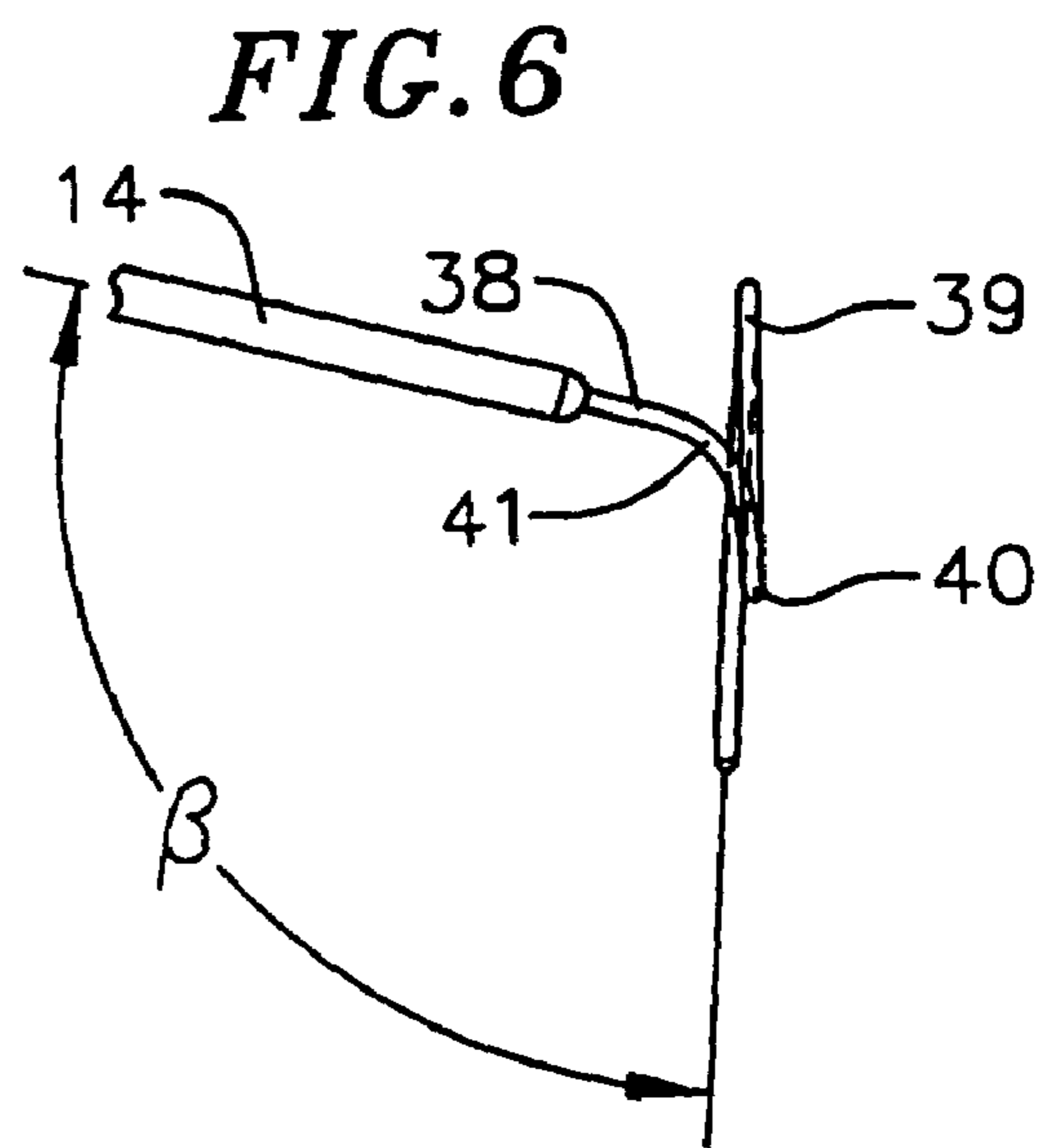
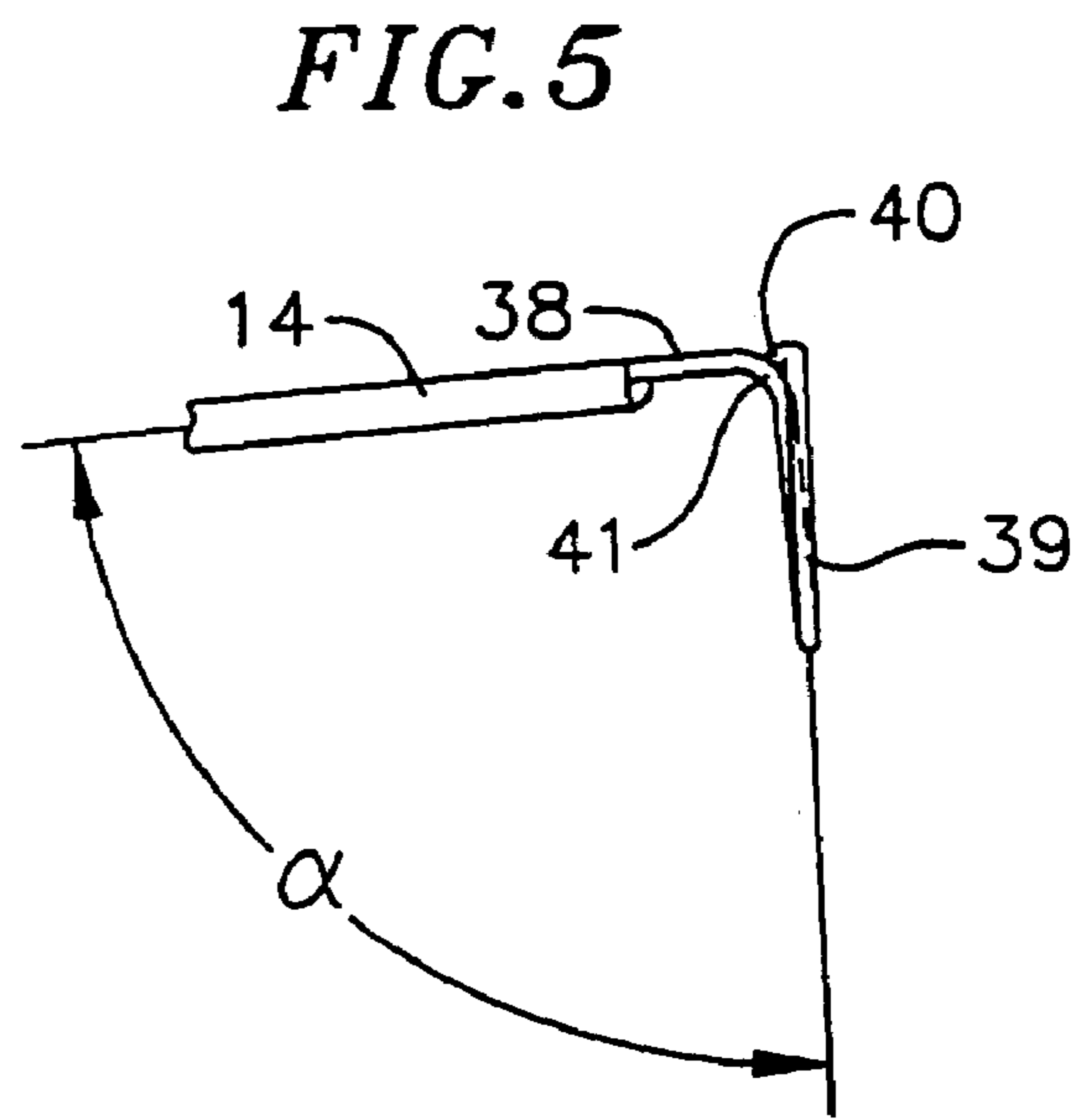
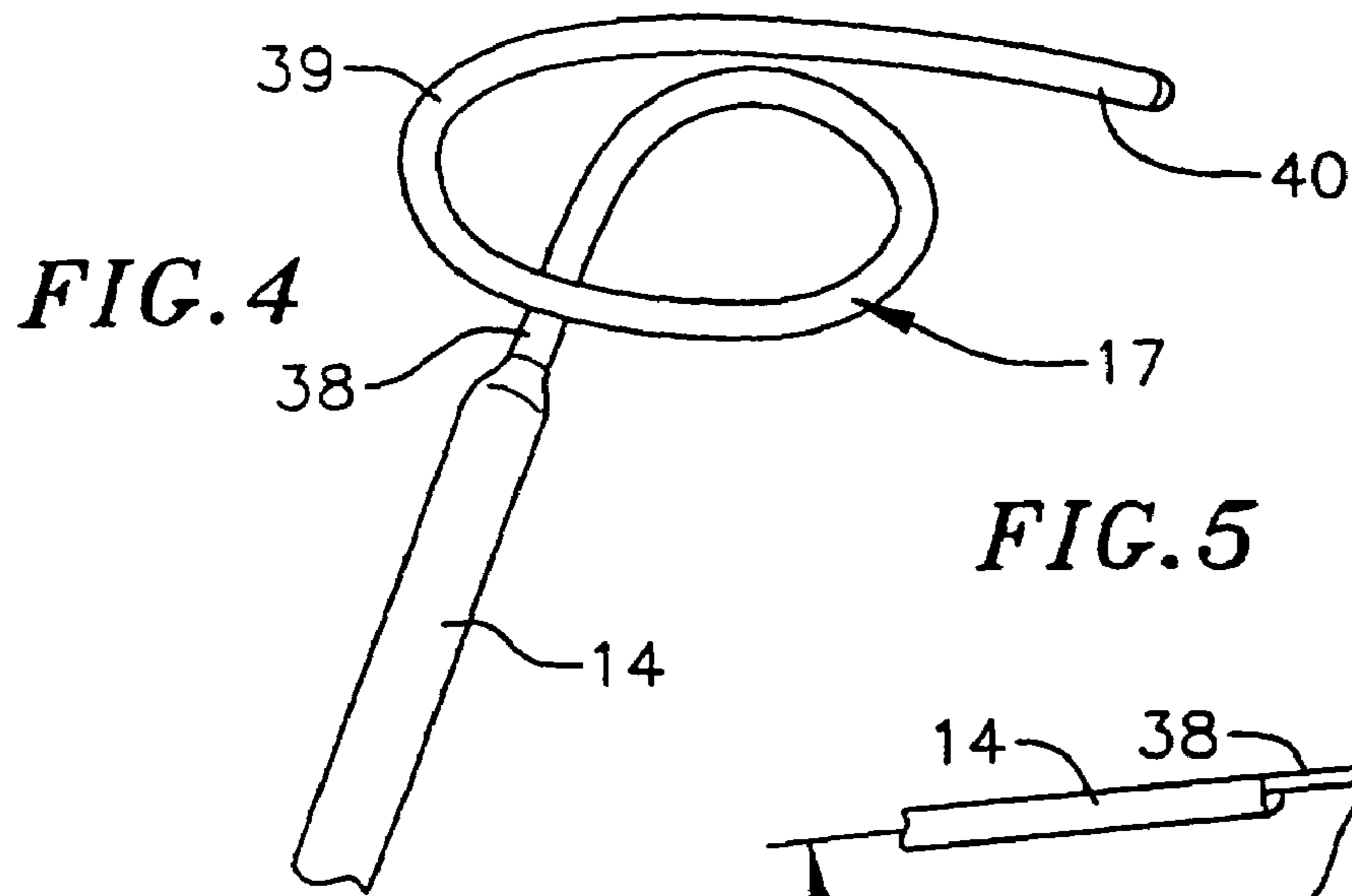

FIG. 7

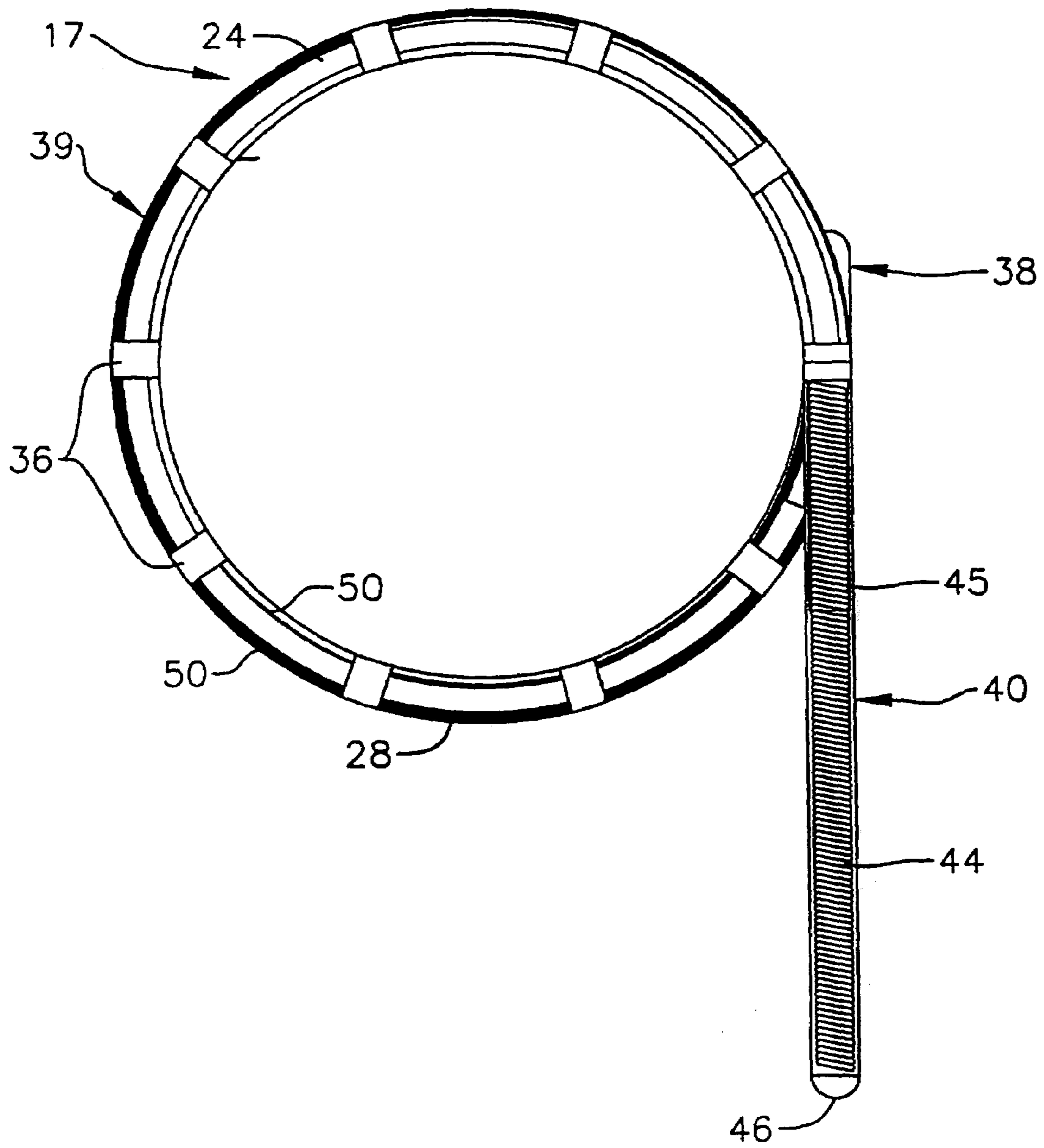
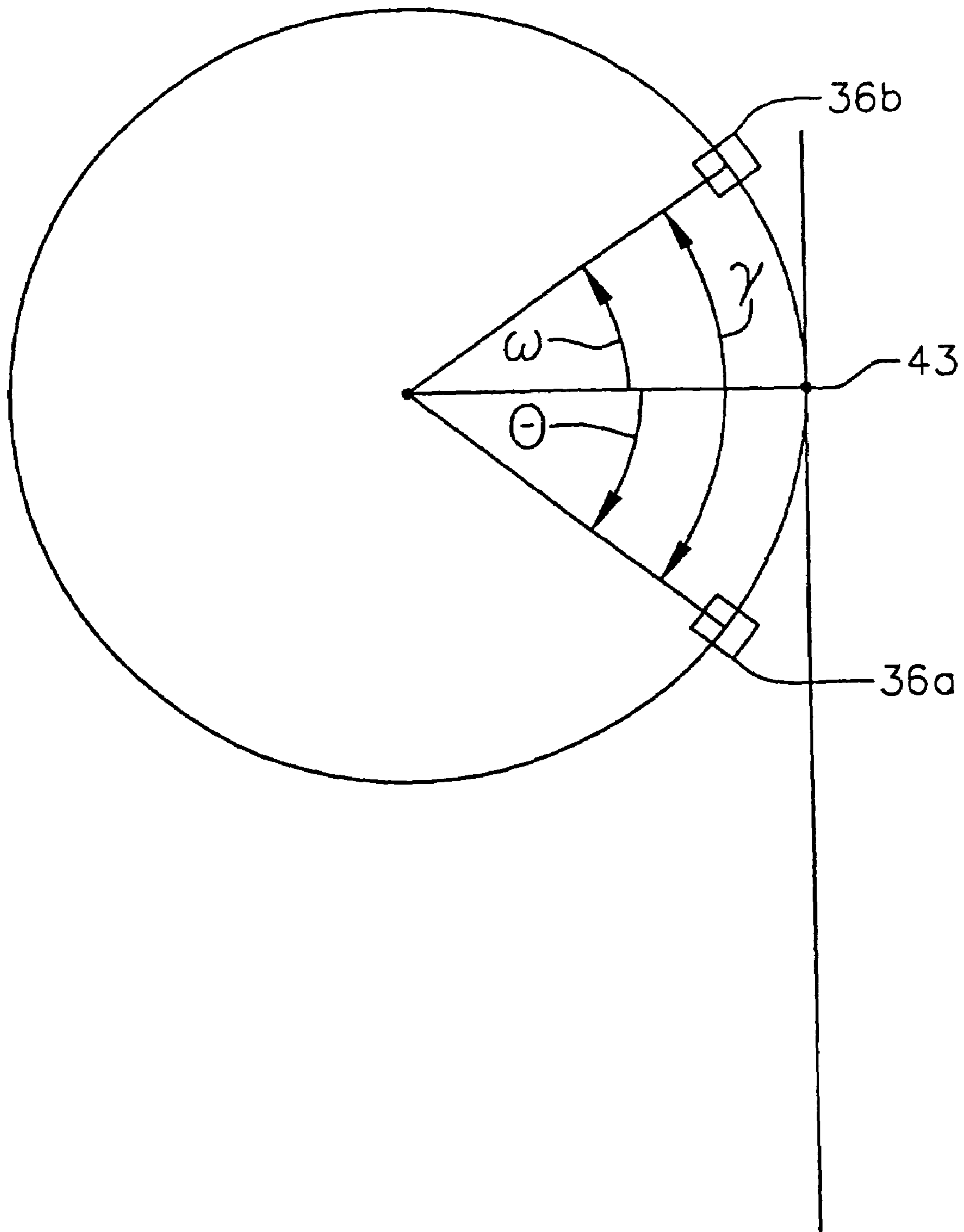

FIG. 8



CATHETER HAVING MAPPING ASSEMBLY

CROSS-REFERENCE TO RELATED APPLICATION(S)

This application is a continuation of U.S. application Ser. No. 10/749,888, filed Dec. 31, 2003 now U.S. Pat. No. 7,123,951, entitled CATHETER HAVING MAPPING ASSEMBLY, which is a continuation of U.S. Ser. No. 10/075,803 filed Feb. 11, 2002 now U.S. Pat. No. 6,804,545 issued Oct. 12, 2004, entitled CATHETER HAVING MAPPING ASSEMBLY, which is a divisional of U.S. Ser. No. 09/551,467 filed Apr. 17, 2000 now U.S. Pat. No. 6,628,976 issued Sep. 30, 2003, entitled CATHETER HAVING MAPPING ASSEMBLY, which claims the benefit of U.S. Provisional Application Ser. No. 60/178,478, filed Jan. 27, 2000, the entire contents of which are incorporated herein by reference.

FIELD OF THE INVENTION

The present invention relates to an improved mapping catheter that is particularly useful for mapping electrical activity in a tubular region of or near the heart.

BACKGROUND OF THE INVENTION

Atrial fibrillation is a common sustained cardiac arrhythmia and a major cause of stroke. This condition is perpetuated by reentrant wavelets propagating in an abnormal atrial-tissue substrate. Various approaches have been developed to interrupt wavelets, including surgical or catheter-mediated ablation. Prior to treating the condition, one has to first determine the location of the wavelets. Various techniques have been proposed for making such a determination. None of the proposed techniques, however, provide for measurement of the activity within a pulmonary vein, coronary sinus or other tubular structure about the inner circumference of the structure.

SUMMARY OF THE INVENTION

The present invention is directed to a catheter having a mapping assembly and a method for measuring electrical activity within a tubular region of or near the heart, e.g., a pulmonary vein, the coronary sinus, the superior vena cava, or the pulmonary outflow tract. The mapping assembly, which has a generally circular region with a series of spaced-apart electrodes mounted thereon, is positioned within the tubular region so that the electrodes are in contact with an inner generally circumferential surface inside the tubular structure.

In one embodiment, the invention is directed to a mapping catheter comprising an elongated tubular catheter body and a mapping assembly mounted at the distal end of the catheter body. The catheter body has an outer wall, proximal and distal ends, and at least on lumen extending therethrough. The mapping assembly comprises a tubular structure having a generally straight proximal region attached to the catheter body, a generally circular main region generally transverse and distal to the proximal region having an outer circumference, a transition region connecting the proximal region and the main region, and a generally straight distal region distal to the main region, preferably extending substantially tangentially to the generally circular main region of the mapping assembly. The assembly further comprises a support member having shape-memory disposed within at least the main region of the mapping assembly. A plurality of spaced-apart electrodes are carried by the generally circular main region of the mapping assembly.

In another embodiment, the invention is directed to a method for mapping electrical activity within a tubular region of or near the heart, wherein the tubular region has an inner generally circumferential surface. The method comprises inserting the distal end of a catheter as described above into the heart. The outer circumference of the generally circular main region of the mapping assembly is contacted with the inner generally circumferential surface of the tubular region. The electrical activity within the tubular region is mapped with the electrodes of the generally circular main region. The method is particularly useful for mapping tubular regions such as pulmonary veins, the coronary sinus, the superior vena cava, and the pulmonary outflow tract.

DESCRIPTION OF THE DRAWINGS

These and other features and advantages of the present invention will be better understood by reference to the following detailed description when considered in conjunction with the accompanying drawings wherein:

FIG. 1 is a side cross-sectional view of an embodiment of the catheter of the invention;

FIG. 2 is a side cross-sectional view of a catheter body according to the invention, including the junction between the catheter body and intermediate section;

FIG. 3 is a cross-sectional view of the intermediate section;

FIG. 4 is a schematic perspective view of the mapping assembly according to the invention;

FIG. 5 is a side view of the mapping assembly according to the invention in a clockwise formation;

FIG. 6 is a side view of the mapping assembly according to the invention in a counterclockwise formation rotated 90° relative to the assembly depicted in FIG. 5;

FIG. 7 is a schematic view of the mapping assembly according to the invention; and

FIG. 8 is a schematic view of the mapping assembly according to the invention depicting the relationship between the first and last electrodes.

DETAILED DESCRIPTION OF THE INVENTION

In a particularly preferred embodiment of the invention, there is provided a catheter having a mapping assembly at its distal end. As shown in FIG. 1, the catheter comprises an elongated catheter body 12 having proximal and distal ends, an intermediate section 14 at the distal end of the catheter body, a control handle 16 at the proximal end of the catheter body, and a mapping assembly 17 mounted at the distal end of the catheter to the intermediate section.

With reference to FIG. 2, the catheter body 12 comprises an elongated tubular construction having a single, axial or central lumen 18. The catheter body 12 is flexible, i.e., bendable, but substantially non-compressible along its length. The catheter body 12 can be of any suitable construction and made of any suitable material. A presently preferred construction comprises an outer wall 20 made of polyurethane or PEBAX. The outer wall 20 comprises an embedded braided mesh of stainless steel or the like to increase torsional stiffness of the catheter body 12 so that, when the control handle 16 is rotated, the intermediate section 14 of the catheter 10 will rotate in a corresponding manner.

The outer diameter of the catheter body 12 is not critical, but is preferably no more than about 8 french, more preferably about 7 french. Likewise, the thickness of the outer wall 20 is not critical, but is thick enough so that the central lumen 18 can accommodate a puller wire, lead wires, and any other desired wires, cables or tubes. If desired, the inner surface of

the outer wall **20** is lined with a stiffening tube (not shown) to provide improved torsional stability. A particularly preferred catheter has an outer wall **20** with an outer diameter of from about 0.090 inch to about 0.94 inch and an inner diameter of from about 0.061 inch to about 0.065 inch.

The intermediate section **14** comprises a short section of tubing **22** having three lumens. The first lumen **30** carries electrode lead wires **50**, the second lumen **32** carries a puller wire **64**, and the third lumen **34** carries a support member **24**. The tubing **22** is made of a suitable non-toxic material that is preferably more flexible than the catheter body **12**. A presently preferred material for the tubing **22** is braided polyurethane, i.e., polyurethane with an embedded mesh of braided stainless steel or the like. The size of each lumen is not critical, but is sufficient to house the lead wires, puller wire or support member.

The useful length of the catheter, i.e., that portion that can be inserted into the body excluding the mapping assembly **17**, can vary as desired. Preferably, the useful length ranges from about 110 cm to about 120 cm, the length of the intermediate section **14** is a relatively small portion of the useful length and preferably ranges from about 3.5 cm to about 10 cm, more preferably from about 5 cm to about 6.5 cm.

A preferred means for attaching the catheter body **12** to the intermediate section **14** is illustrated in FIG. 2. The proximal end of the intermediate section **14** comprises an outer circumferential notch **26** that receives the inner surface of the outer wall **22** of the catheter body **12**. The intermediate section **14** and catheter body **12** are attached by glue or the like.

If desired, a spacer (not shown) can be located within the catheter body between the distal end of the stiffening tube (if provided) and the proximal end of the intermediate section. The spacer provides a transition in flexibility at the junction of the catheter body and intermediate section, which allows this junction to bend smoothly without folding or kinking. A catheter having such a spacer is described in U.S. Pat. No. 5,964,757, the disclosure of which is incorporated herein by reference.

At the distal end of the intermediate section **14** is a mapping assembly, as shown in FIGS. 3 to 7. The mapping assembly is formed from the distal end of the support member **24** covered by a non-conductive covering **28**. The mapping assembly comprises a generally straight proximal region **38**, a generally circular main region **39** and a generally straight distal region **40**. The proximal region **38** is mounted on the intermediate section **14**, as described in more detail below, so that its axis is generally parallel to the axis of the intermediate section. The proximal region **39** preferably has an exposed length, e.g., not contained within the intermediate section **14**, ranging from about 3 mm to about 12 mm, more preferably about 3 mm to about 8 mm, still more preferably about 5 mm, but can vary as desired.

The generally circular main region **39** does not form a flat circle, but is very slightly helical, as shown in FIGS. 4 to 6. The main region **39** has an outer diameter preferably ranging from about 10 mm to about 25 mm, more preferably from about 12 mm to about 22 mm, still more preferably about 15 mm. The transition region **41** of the straight proximal region **38** and generally circular main region **39** is slightly curved and formed such that, when viewed from the side with the proximal region at the top of the circular main region as shown in FIG. 5, the proximal region (along with the intermediate section **14**) forms an angle α with the curved region ranging from about 75° to about 95°, preferably from about 83° to about 93°, more preferably about 87°. The main region **39** can curve in a clockwise direction, as shown in FIG. 5, or a counterclockwise direction, as shown in FIG. 6, so that the

transition region **41** is near the center of the main region, the proximal region (along with the intermediate section **14**) forms an angle β with the main region ranging from about 90° to about 135°, preferably from about 100° to about 110°, more preferably about 105°.

The support member **24** is made of a material having shape-memory, i.e., that can be straightened or bent out of its original shape upon exertion of a force and is capable of substantially retuning to its original shape upon removal of the force. A particularly preferred material for the support member **24** is a nickel/titanium alloy. Such alloys typically comprise about 55% nickel and 45% titanium. A preferred nickel/titanium alloy is nitinol, which has excellent shape memory, together with ductility, strength, corrosion resistance, electrical resistivity and temperature stability. The non-conductive covering **28** can be made of any suitable material, and is preferably made of a biocompatible plastic such as polyurethane or PEBAX.

A series of ring electrodes **36** are mounted on the non-conductive covering **28** of the generally circular main region **39** of the mapping assembly **17**. The ring electrodes **36** can be made of any suitable solid conductive material, such as platinum or gold, preferably a combination of platinum and iridium, and mounted onto the non-conductive covering **28** with glue or the like. Alternatively, the ring electrodes can be formed by coating the non-covering **28** with an electrically conducting material, like platinum, gold and/or iridium. The coating can be applied using sputtering, ion beam deposition or an equivalent technique.

In a preferred embodiment, each ring electrode **36** is mounted by first forming a hole in the non-conductive covering **28**. An electrode lead wire **50** is fed through the hole, and the ring electrode **36** is welded in place over the lead wire and non-conductive covering **28**. The lead wires **50** extend between the non-conductive covering **28** and the support member **24** the proximal end of each lead wire **50** is electrically connected to a suitable connector **37**, which is connected to a source of RF energy (not shown).

The number of ring electrodes **36** on the assembly can vary as desired. Preferably, the number of ring electrodes ranges from about 6 to about 20, more preferably from about 8 to about 12. In a particularly preferred embodiment, the assembly carries 10 ring electrodes. The ring electrodes **36** are preferably approximately evenly spaced around the generally circular main region **39**, as best shown in FIG. 7. In a particularly preferred embodiment, a distance of approximately 5 mm is provided between the centers of the ring electrodes **36**.

FIGS. 7 and 8 show a particularly preferred electrode arrangement. As explained above, the generally circular main region **39** is very slightly helical, although FIGS. 7 and 8 depict the main region as a flat circle, as it would generally appear when viewed from the distal end of the catheter. The generally straight distal region **40** forms a tangent relative to the generally circular main region **39** and contacts the main region at a tangent point **43**. A first electrode **36a** is provided, which is the electrode that is on the generally circular main region **39** closest to the proximal region **38**. A second electrode **36b** is provided, which is the electrode that is on the generally circular main region **39** closest to the distal region **40**. Preferably, the first electrode **36a** is positioned along the circumference of the generally circular main region **39** at a distance θ of no more than about 55° from the tangent point, more preferably no more than about 48° from the tangent point, still more preferably from about 15° to about 36° from the tangent point. Preferably, the second **36b** is position along the circumference of the generally circular main region **39** at a distance ω of no more than about 55° from the tangent point,

5

more preferably no more than about 48° from the tangent point, still more preferably from about 15° to about 36° from the tangent point. Preferably, the first electrode **36a** is positioned along the circumference of the generally circular main region **39** at a distance γ of no more than 100° from the second electrode preferably no more than 80° from the second electrode, still more preferably from about 30° to about 75° from the second electrode.

If desired, additional electrodes (not shown) could be mounted along the intermediate section **14**, the generally straight proximal section **38**, the transition region **41**, and the generally straight distal region **40**.

The generally straight distal region **40** is provided with an atraumatic design to prevent the distal end of the mapping assembly **17** from penetrating tissue. In the depicted embodiment, the distal region **40** comprises a tightly wound coil spring **44** made, for example, of stainless steel, such as the mini guidewire commercially available from Cordis Webster (Miami, Fla.) or a coil having a 0.0045 inch wire size and a 0.009 inch inner diameter, such as that commercially available from Microspring. The coil spring **44** is mounted at its proximal end in a short piece of tubing **45** with polyurethane glue or the like, which is then glued or otherwise anchored within the non-conductive covering **28**. The tubing **45** is less flexible than the non-conductive covering **28** but more flexible than the support member **24** to provide a transition in flexibility along the length of the mapping assembly **17**. In the depicted embodiment, the generally straight distal region **40** has a length of about 0.5 inch, but can be any desired length, for example, ranging from about 0.25 inch to about 1.0 inch. The generally straight distal region **40** is preferably sufficiently long to serve as an anchor for introducing the catheter into a guiding sheath, as discussed in more detail below, because the mapping assembly **17** must be straightened upon introduction into the sheath. Without having the generally straight distal region **40** as an anchor, the mapping assembly **17** has a tendency to pull out of the guiding sheath upon its introduction into the guiding sheath. Additionally, if desired, the distal region **40** can be formed, at least in part, of a radiopaque material to aid in the positioning of the mapping assembly **17** under fluoroscopy.

The junction of the intermediate section **14** and mapping assembly **17** is shown in FIG. 3. The non-conductive covering **28** is attached to the tubing **22** of the intermediate section by glue or the like. The support member **24** extends from the third lumen **32** into the non-conductive covering **28**. The proximal end of the support member **24** terminates a short distance within the third lumen **32**, about 5 mm, so as not to adversely affect the ability of the intermediate section **14** to deflect. However, if desired, the proximal end of the support member **24** can extend into the catheter body **12**.

The lead wires **50** attached to the ring electrodes **36** extend through the first lumen **30** of the intermediate section **14**, through the central lumen **18** of the catheter body **12**, and the control handle **16**, and terminate at their proximal end in the connector **37**. The portion of the lead wires **50** extending through the central lumen **18** of the catheter body **12**, control handle **16** and proximal end of the intermediate section **14** are enclosed within a protective sheath **62**, which can be made of any suitable material, preferably polyimide. The protective sheath **62** is anchored at its distal end to the proximal end of the intermediate section **14** by gluing it in the first lumen **30** with polyurethane glue or the like.

The puller wire **64** is provided for deflection of the intermediate section **14**. The puller wire **64** extends through the catheter body **12**, is anchored at its proximal end to the control handle **16**, and is anchored at its distal end to the intermediate

6

section **14**. The puller wire **64** is made of any suitable metal, such as stainless steel or nitinol, and is preferably coated with Teflon® or the like. The coating imparts lubricity to the puller wire **64**. The puller wire **64** preferably has a diameter ranging from about 0.006 inch to about 0.010 inch.

A compression coil **66** is situated within the catheter body **12** in surrounding relation to the puller wire **64**. The compression coil **66** extends from the proximal end of the catheter body **12** to the proximal end of the intermediate section **14**. The compression coil **66** is tightly wound on itself to provide flexibility, i.e., bending, but to resist compression. The inner diameter of the compression coil **66** is preferably slightly larger than the diameter of the puller wire **64**. The Teflon® coating on the puller wire **64** allows it to slide freely within the compression coil **66**, the outer surface of the compression coil **66** is covered by a flexible, non-conductive sheath **68**, e.g., made of polyimide tubing.

The compression coil **66** is anchored at its proximal end to the outer wall **20** of the catheter body **12** by proximal glue joint **70** and at its distal end to the intermediate section **14** by distal glue joint **72**. Both glue joints **70** and **72** preferably comprise polyurethane glue or the like. The glue may be applied by means of a syringe or the like through a hole made between the outer surface of the catheter body **12** and the central lumen **18**. Such a hole may be formed, for example, by a needle or the like that punctures the outer wall **20** of the catheter body **12** which is heated sufficiently to form a permanent hole. The glue is then introduced through the hole to the outer surface of the compression coil **66** and wicks around the outer circumference to form a glue joint about the entire circumference of the compression coil.

The puller wire **64** extends into the second lumen **32** of the intermediate section **14**. Preferably the puller wire **64** is anchored at its distal end to the distal end of the intermediate section **14**, as shown in FIG. 3. Specifically, a T-shaped anchor is formed, which comprises a short piece of tubular stainless steel **80**, e.g., hypodermic stock, which is fitted over the distal end of the puller wire **64** and crimped to fixedly secure it to the puller wire. The distal end of the tubular stainless steel **80** is fixedly attached, e.g., by welding, to a cross-piece **82** formed of stainless steel ribbon or the like. The cross-piece **82** sits beyond the distal end of the second lumen **32**. The cross-piece **82** is larger than the lumen opening and, therefore, cannot be pulled through the opening. The distal end of the second lumen **32** is then filled with glue or the like. Preferably a polyurethane glue. Within the second lumen **32** of the intermediate section **14**, the puller wire **64** extends through a plastic, preferably Teflon®, puller wire sheath (not shown), which prevents the puller wire **64** from cutting into the wall of the intermediate section **14** when the intermediate section is deflected.

Longitudinal movement of the puller wire **64** relative to the catheter body **12**, which results in deflection of the intermediate section **14**, is accomplished by suitable manipulation of the control handle **16**. Examples of suitable control handles for use in the present invention are disclosed, for example, in U.S. Pat. Nos. Re 34,502 and 5,897,529, the entire disclosures of which are incorporated herein by reference.

In use, a suitable guiding sheath is inserted into the patient with its distal end positioned at a desired mapping location. An example of a suitable guiding sheath for use in connection with the present invention is the Preface™ Guiding Sheath, commercially available from Cordis Webster (Diamond Bar, Calif.). The distal end of the sheath is guided into one of the atria. A catheter in accordance with the present invention is fed through the guiding sheath until its distal end extends out of the distal end of the guiding sheath. As the catheter is fed

through the guiding sheath, the mapping assembly 17 is straightened to fit through the sheath. Once the distal end of the catheter is positioned at the desired mapping location, the guiding sheath is pulled proximally, allowing the deflectable intermediate section 14 and mapping assembly 17 to extend 5 outside the sheath, and the mapping assembly 17 returns to its original shape due to the shape-memory of the support member 24. The mapping assembly 17 is then inserted onto a pulmonary vein or other tubular region (such as the coronary sinus, superior vena cava, or inferior vena cava) so that the 10 outer circumference of the generally circular main region 39 of the assembly is in contact with a circumference inside the tubular region. Preferably, at least about 50%, more preferably at least about 70%, and still more preferably at least about 80% of the circumference of the generally circular 15 main region is in contact with a circumference inside the tubular region.

The circular arrangement of the electrodes 36 permits measurement of the electrical activity at that circumference of the tubular structure so that ectopic beats between the electrodes 20 can be identified. The size of the generally circular main region 39 permits measurement of electrical activity along a diameter of a pulmonary vein or other tubular structure of or near the heart because the circular main region has a diameter generally corresponding to that of a pulmonary vein or the 25 coronary sinus. Additionally, because the main region 39 preferably does not form a flat circle, but instead is somewhat helical, as shown in FIG. 4, it is easier for the user to guide the mapping assembly 17 into a tubular region.

If desired, two or more puller wires can be provided to 30 enhance the ability to manipulate the intermediate section. In such an embodiment, a second puller wire and a surrounding second compression coil extend through the catheter body and into an additional off-axis lumen in the intermediate section. The first puller wire is preferably anchored proximal 35 to the anchor location of the second puller wire. Suitable designs of catheters having two or more puller wires, including suitable control handles for such embodiment, are described, for example, in U.S. patent application Ser. No. 08/924,611, filed Sep. 5, 1997; Ser. No. 09/130,359, filed 40 Aug. 7, 1998; Ser. No. 09/143,426, filed Aug. 28, 1998; and Ser. No. 09/157,055, filed Sep. 18, 1998, disclosures of which are incorporated herein by reference.

The preceding description has been presented with reference to presently preferred embodiments of the invention. 45 Workers skilled in the art and technology to which this invention pertains will appreciate that alterations and changes in the described structure may be practiced without meaningfully departing from the principal, spirit and scope of this invention.

Accordingly, the foregoing description should not be read as pertaining only to the precise structures described and 50 illustrated in the accompanying drawings, but rather should be read consistent with and as support for the following claims which are to have their fullest and fairest scope.

What is claimed is:

1. A mapping catheter comprising:

an elongated tubular catheter body having an outer wall, proximal and distal ends, and at least one lumen extending 55 therethrough;

an intermediate section having proximal and distal ends and at least one lumen extending therethrough, the proximal end of the intermediate section being attached to the distal end of the catheter body; and

a mapping assembly comprising:

a tubular structure having a generally straight proximal region attached to the intermediate section, a gener-

ally circular main region generally transverse and distal to the proximal region having an outer circumference, a transition region connecting the proximal region and the main region, and a generally straight 5 distal region distal the main region and extending substantially tangentially from the main region, wherein the tubular structure comprises a non-conductive cover over at least the main region of the mapping assembly,

a support member having shape-memory disposed within at least the main region of the mapping assembly; and

a plurality of spaced-apart electrodes carried by the generally circular main region of the mapping assembly.

2. A catheter according to claim 1, wherein the intermediate section has three lumens extending therethrough.

3. A catheter according to claim 1, wherein the generally circular main region has an outer diameter ranging from about 10 mm to about 25 mm.

4. A catheter according to claim 1, wherein the generally circular main region has an outer diameter ranging from about 12 mm to about 22 mm.

5. A catheter according to claim 1, wherein the generally circular main region has an outer diameter of about 15 mm.

6. A catheter according to claim 1, wherein the transition region is slightly curved and formed such that, when viewed from a side of the catheter with the proximal region at the top of the circular main region, the proximal region forms an angle α with the circular region ranging from about 75° to about 95°.

7. A catheter according to claim 1, wherein the transition region is slightly curved and formed such that, when viewed from a side of the catheter with the proximal region at the top of the circular main region, the proximal region forms an angle α with the circular main region ranging from about 83° to about 93°.

8. A catheter according to claim 1, wherein the number of electrodes along the generally circular main region ranges from about 6 to about 20.

9. A catheter according to claim 1, wherein the number of electrodes along the generally circular main region ranges from about 8 to about 12.

10. A catheter according to claim 1, wherein the electrodes are approximately evenly spaced around the generally circular main region.

11. A catheter according to claim 1, wherein the generally straight proximal region has an exposed length ranging from about 3 mm to about 12 mm.

12. A catheter according to claim 1, wherein the generally straight proximal region has an exposed length ranging from about 3 mm to about 8 mm.

13. A catheter according to claim 1, wherein the generally straight distal region has an atraumatic design to prevent the distal end of the mapping assembly from penetrating tissue.

14. A catheter according to claim 1, wherein the generally straight distal region has a length ranging from about 0.25 inch to about 1.0 inch.

15. A catheter according to claim 1, further comprising a control handle mounted at the proximal end of the catheter body and means for deflecting the intermediate section by manipulation of the control handle.

16. A catheter according to claim 15, wherein the control handle comprises a first member fixedly attached to the proximal end of the catheter body and a second member that is movable relative to the first member.

17. A catheter according to claim 16, wherein the deflecting means comprises a puller wire having a proximal end and

9

a distal end, the puller wire extending from the control handle, through the catheter body and into a lumen in the intermediate section, wherein the distal end of the puller wire is fixedly secured within the intermediate section and the proximal end of the puller wire is fixedly secured to the second member of the control handle, whereby manipulation of the first member

10

of the control handle relative to the second member of the control handle moves the puller wire relative to the catheter body, resulting in deflection of the intermediate section.

* * * * *

UNITED STATES PATENT AND TRADEMARK OFFICE
CERTIFICATE OF CORRECTION

PATENT NO. : 7,570,982 B2
APPLICATION NO. : 11/582623
DATED : August 4, 2009
INVENTOR(S) : Kristine B. Fuimaono

Page 1 of 1

It is certified that error appears in the above-identified patent and that said Letters Patent is hereby corrected as shown below:

Column 8, line 35, "a" should be -- α --

Signed and Sealed this

Sixteenth Day of March, 2010

A handwritten signature in black ink that reads "David J. Kappos". The signature is written in a cursive style with a large, prominent "D" and "K".

David J. Kappos
Director of the United States Patent and Trademark Office