

US007562483B2

(12) **United States Patent**  
**Hines**

(10) **Patent No.:** **US 7,562,483 B2**  
(45) **Date of Patent:** **Jul. 21, 2009**

(54) **MODULAR RAIL COVER**

(76) Inventor: **Steve Hines**, P.O. Box 423, Tijeras, NM  
(US) 87059

6,609,321 B2 \* 8/2003 Faifer ..... 42/71.01  
6,725,594 B2 4/2004 Hines ..... 42/90  
6,792,711 B2 9/2004 Battaglia ..... 42/114  
2006/0075672 A1 \* 4/2006 Romer ..... 42/10

(\*) Notice: Subject to any disclaimer, the term of this patent is extended or adjusted under 35 U.S.C. 154(b) by 359 days.

\* cited by examiner

(21) Appl. No.: **11/706,665**

*Primary Examiner*—J. Woodrow Eldred  
(74) *Attorney, Agent, or Firm*—Richard H. Krukar; Luis M. Ortiz; Kermit D. Lopez

(22) Filed: **Feb. 12, 2007**

(57) **ABSTRACT**

(65) **Prior Publication Data**

US 2008/0190002 A1 Aug. 14, 2008

A modular rail cover can have rail cover modules and rail cover sections that can be snapped onto or slid onto a mounting rail. Rail cover modules have recoil sockets into which recoil plugs are inserted. The recoil plugs engage recoil grooves such as those in Picatinny type mounting rails to fix the rail cover modules into position. The rail cover sections have section couplers that engage corresponding module couplers on the rail cover modules. The section couplers and module couplers lock rail cover sections to rail cover modules. Section couplers can also lock rail cover sections to one another.

(51) **Int. Cl.**

*F41G 1/38* (2006.01)

(52) **U.S. Cl.** ..... 42/90; 42/96; 42/85; 42/71.01

(58) **Field of Classification Search** ..... 42/90,  
42/96, 85, 71.01

See application file for complete search history.

(56) **References Cited**

U.S. PATENT DOCUMENTS

5,826,363 A 10/1998 Olson ..... 42/75.01

**20 Claims, 6 Drawing Sheets**

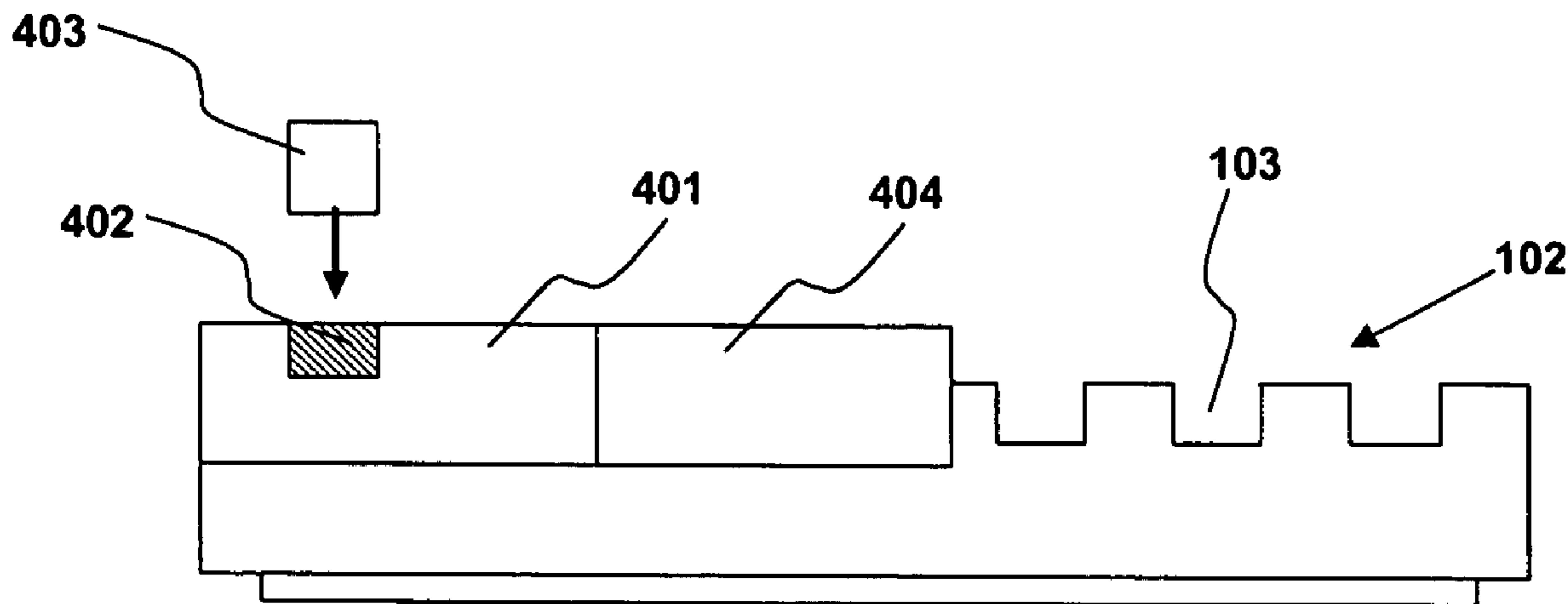

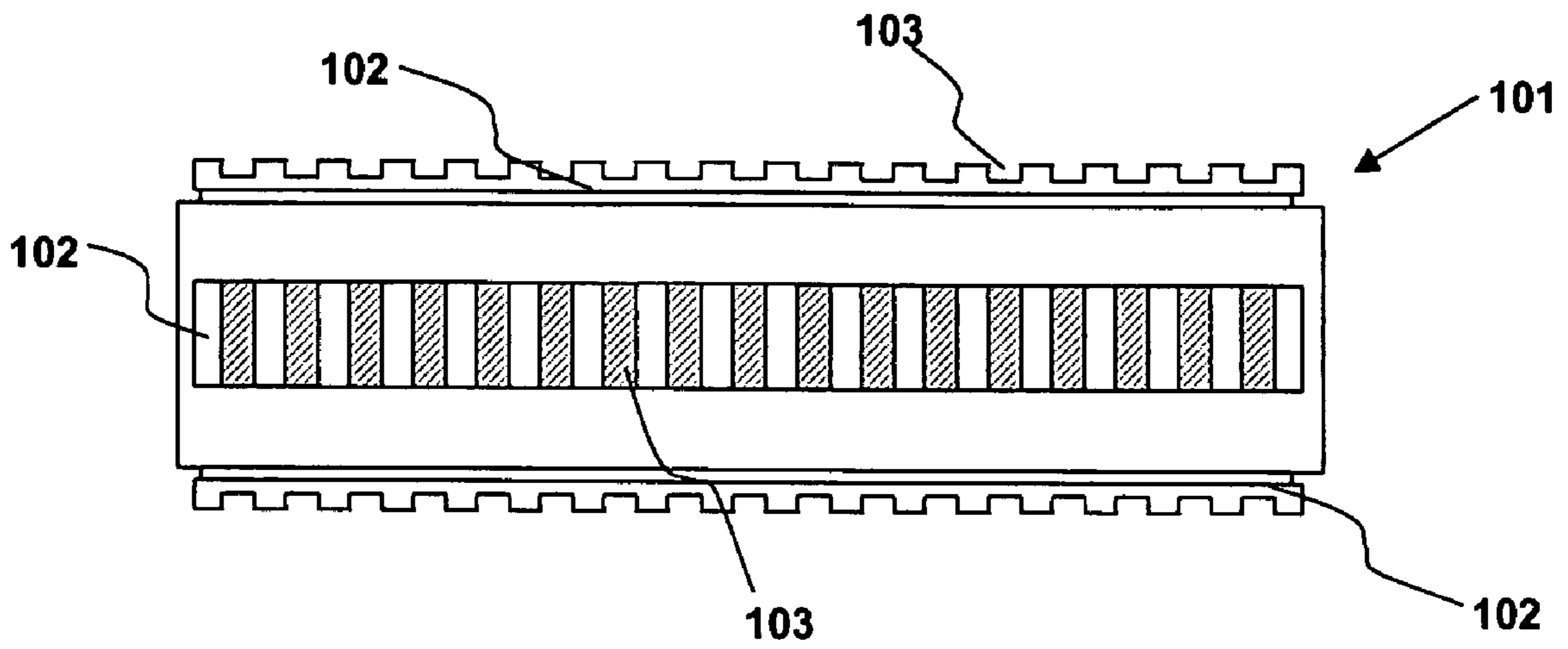

*Fig. 1 (Prior Art)*

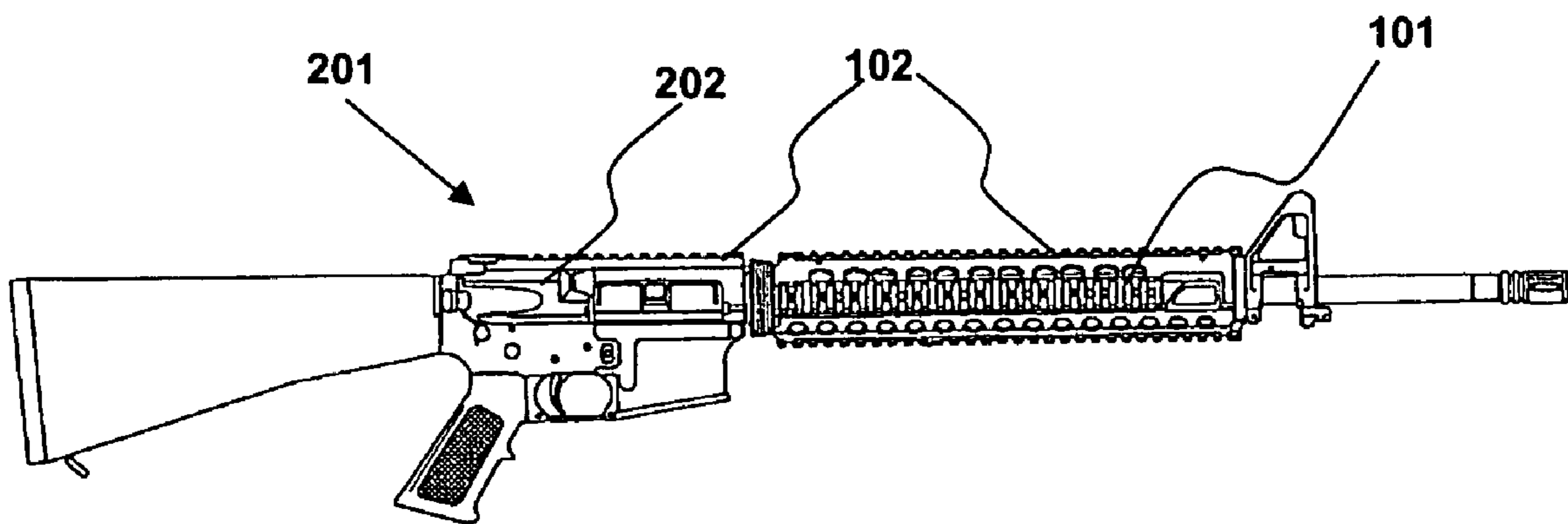

*Fig. 2 (Prior Art)*

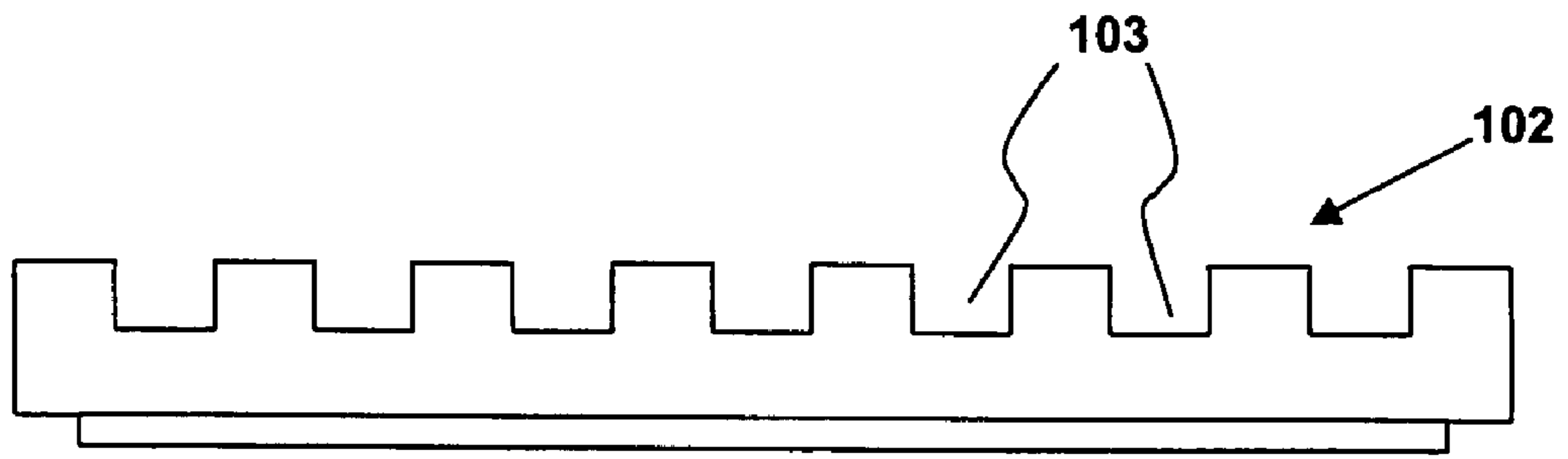

Fig. 3

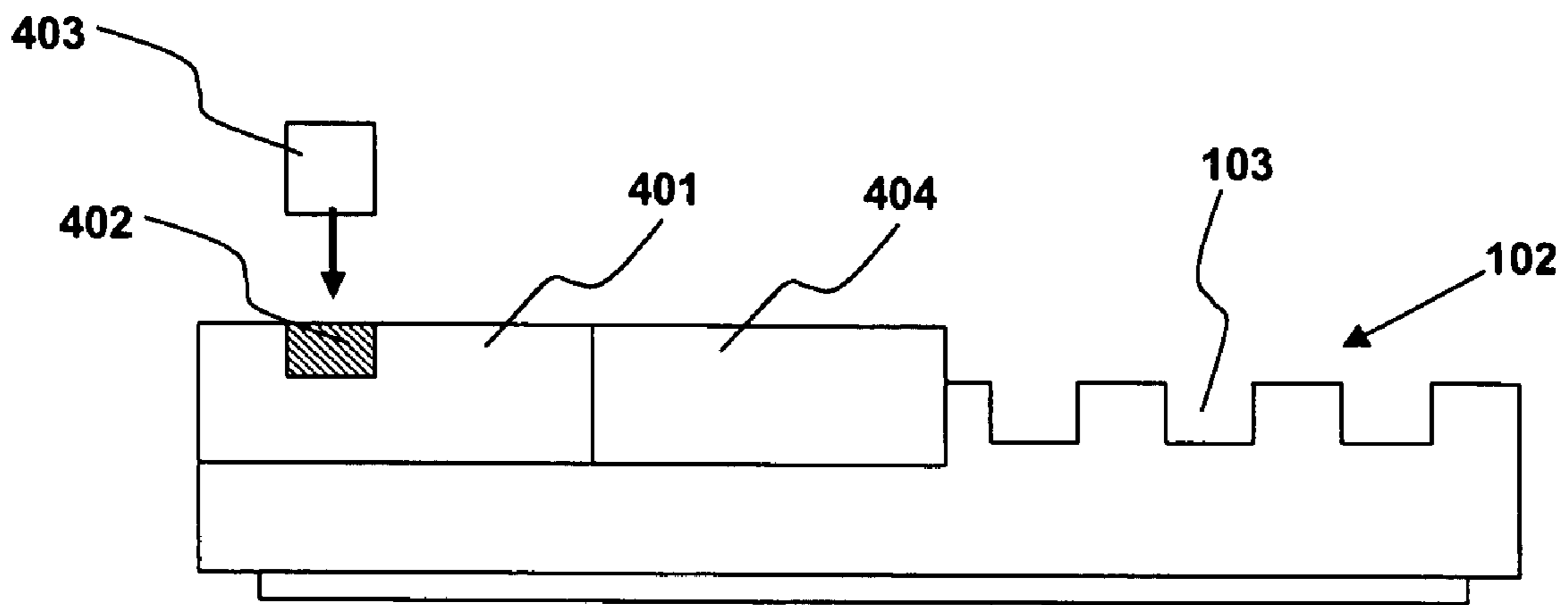

Fig. 4

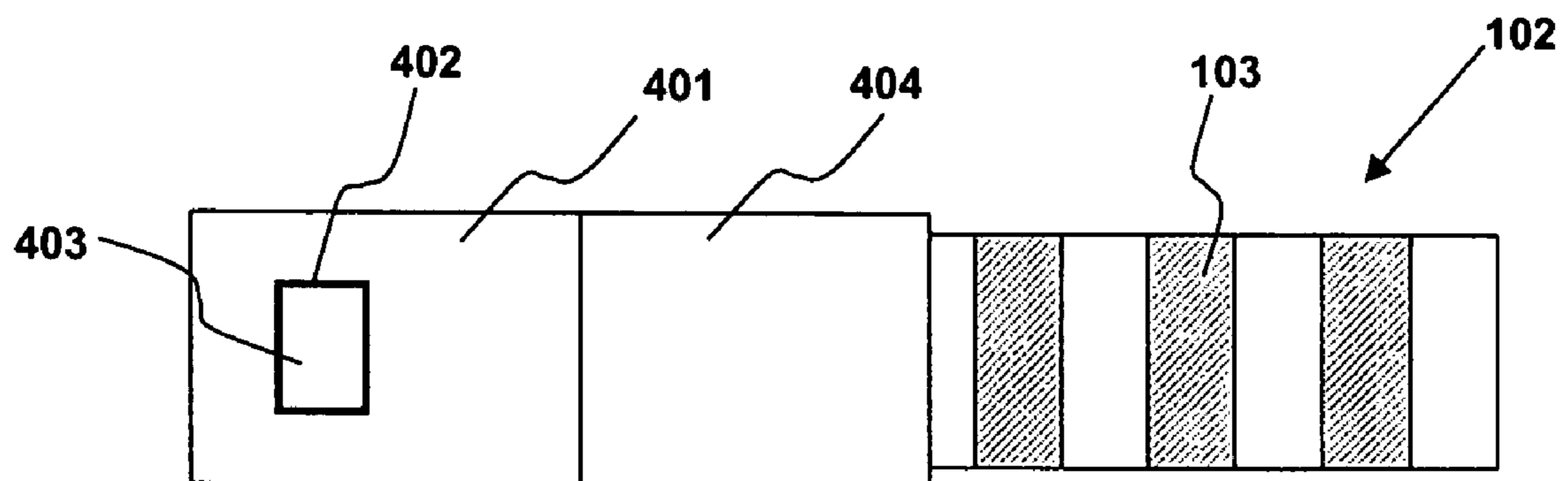
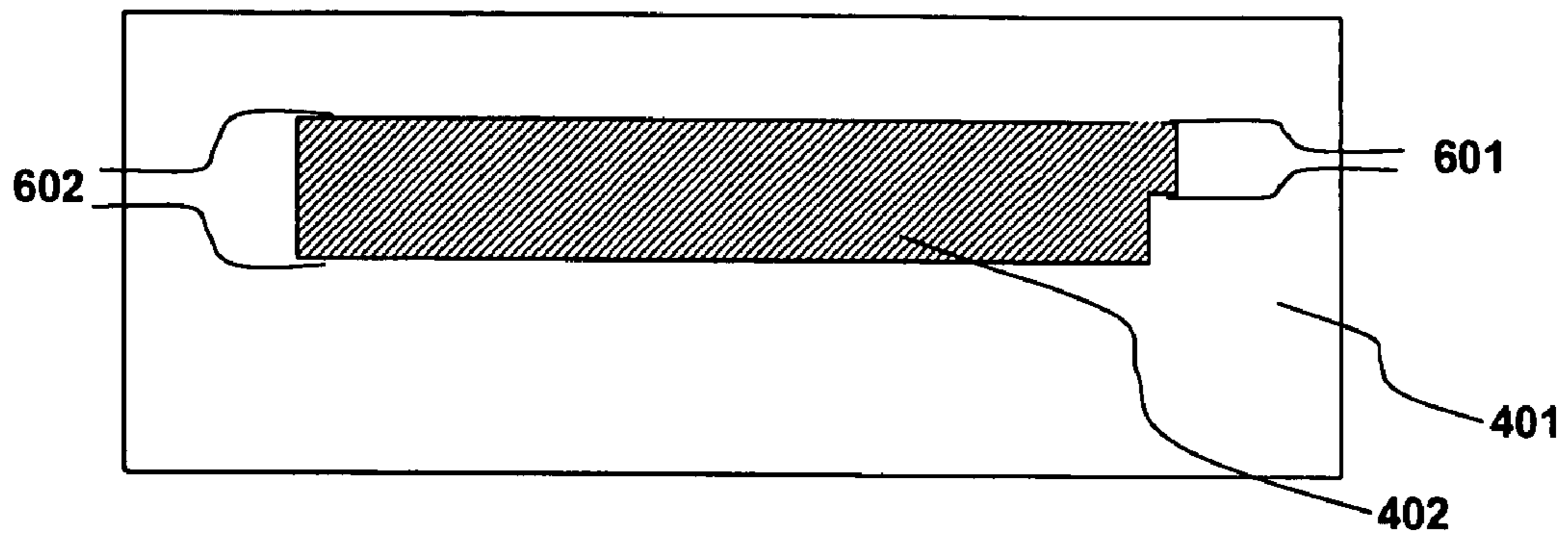
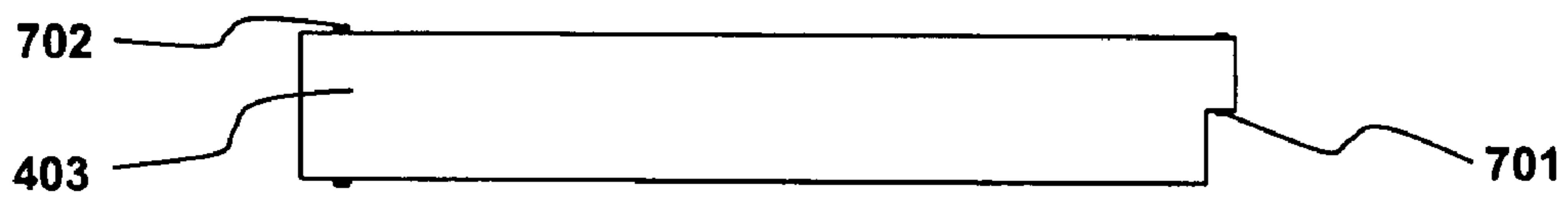

Fig. 5



*Fig. 6*



*Fig. 7A*

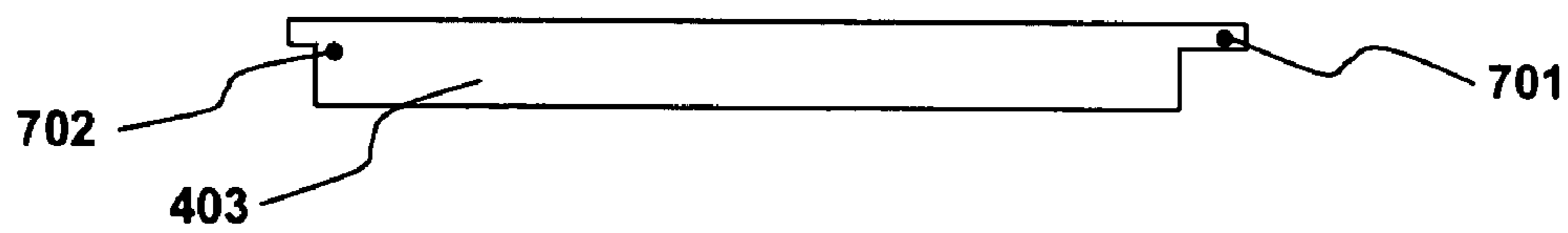

*Fig. 7B*

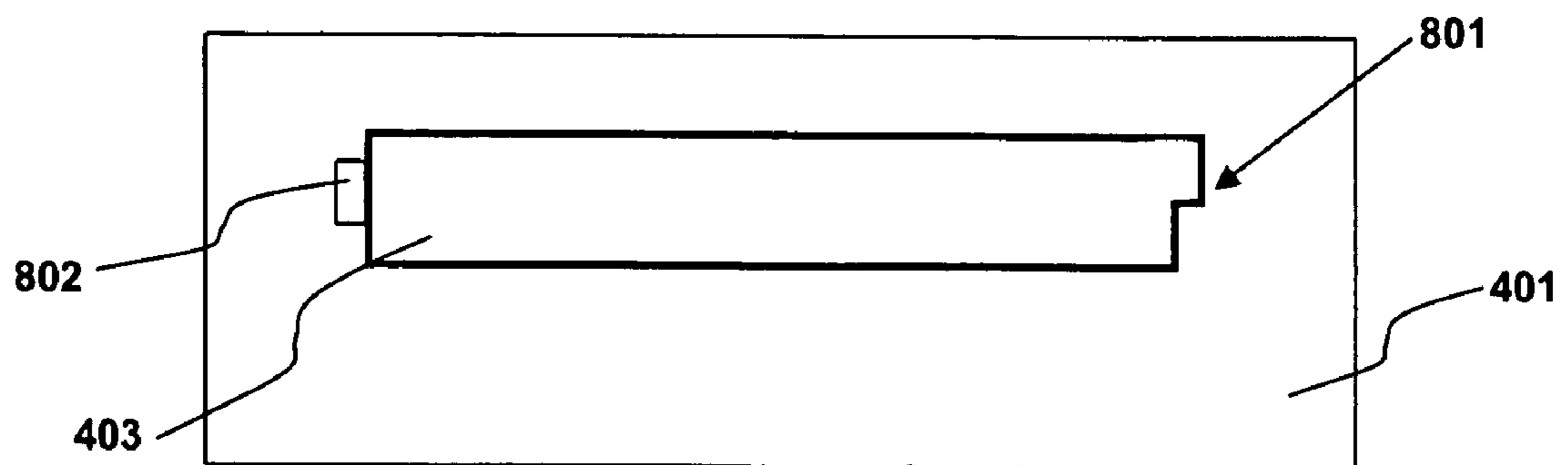

*Fig. 8*

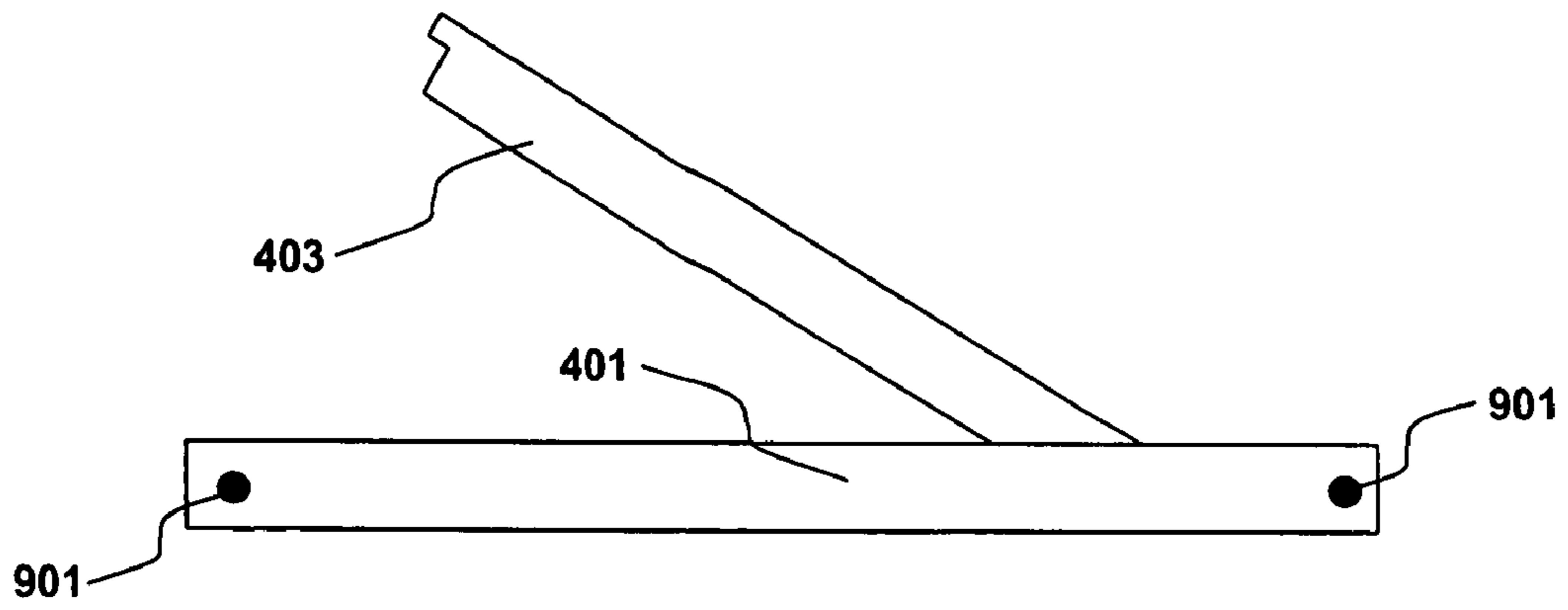

*Fig. 9*

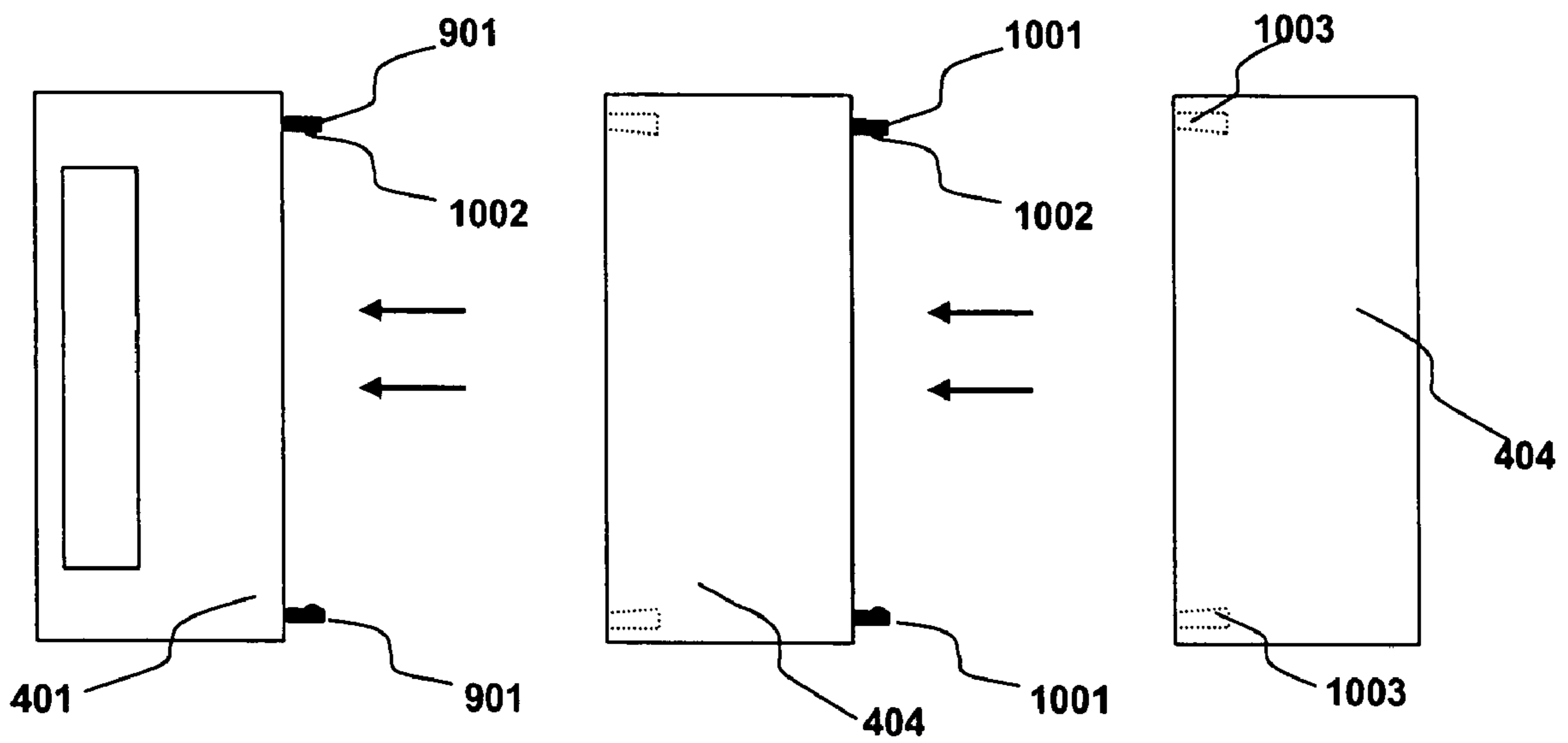

*Fig. 10*

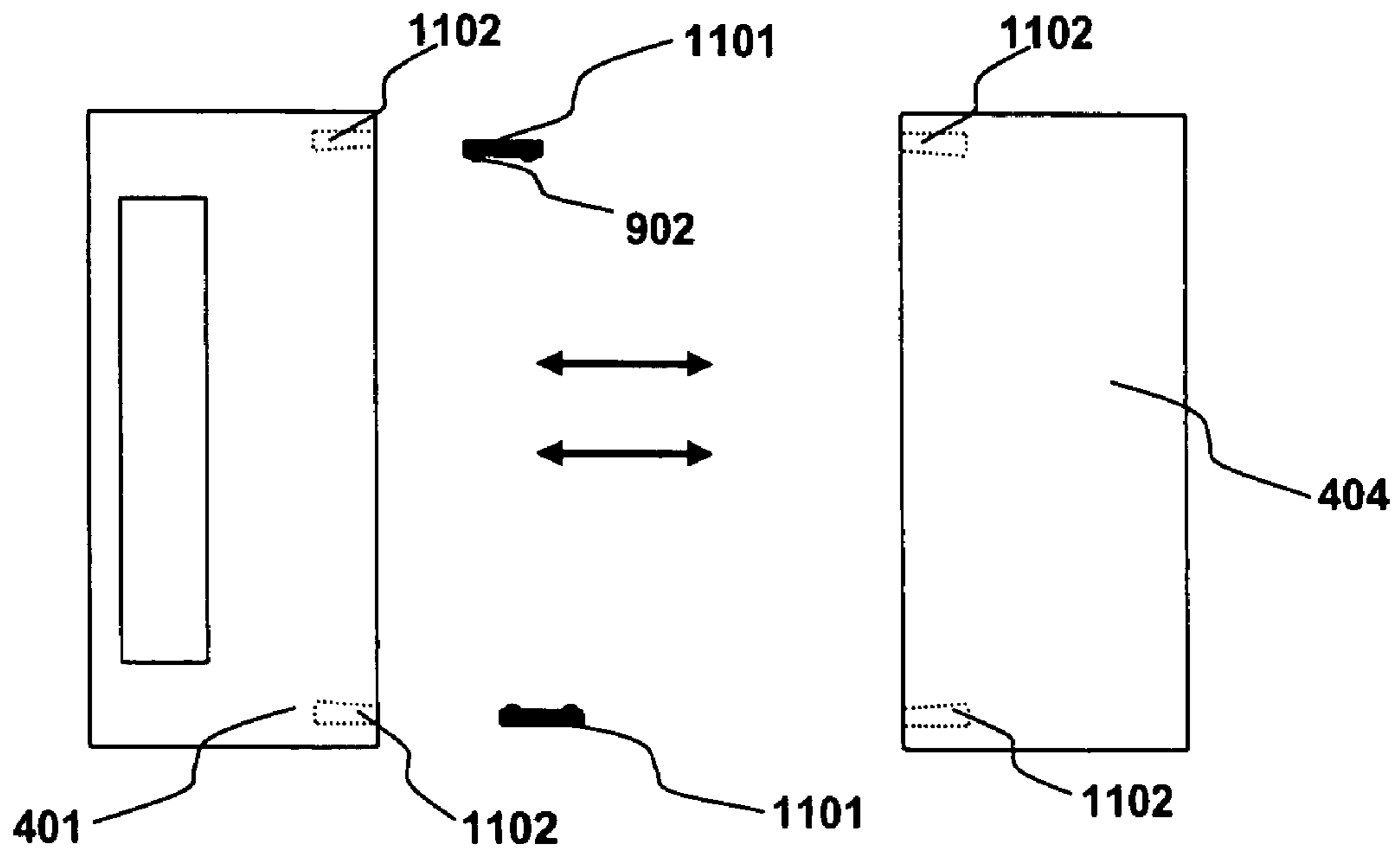

*Fig. 11*

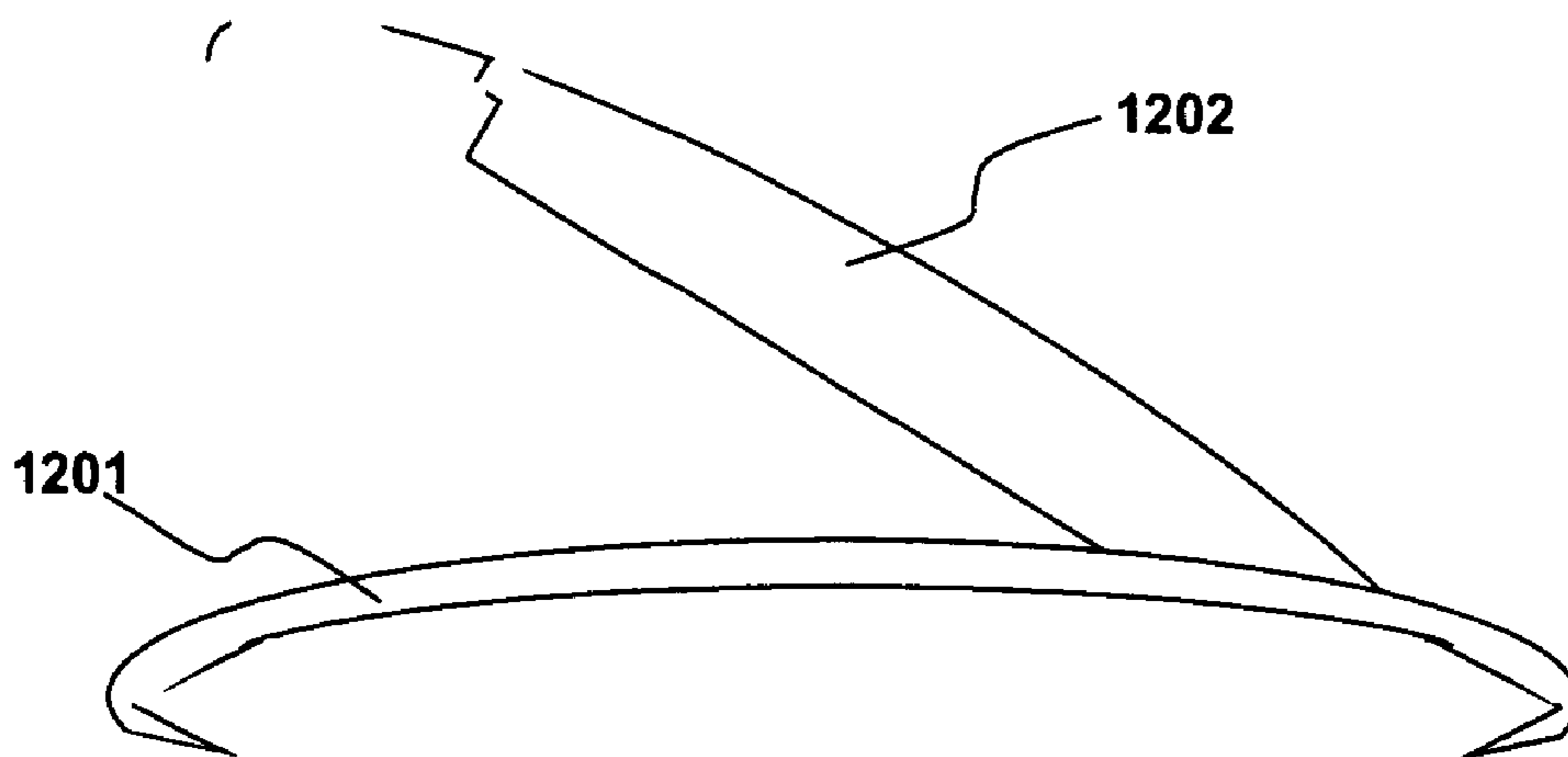

*Fig. 12*

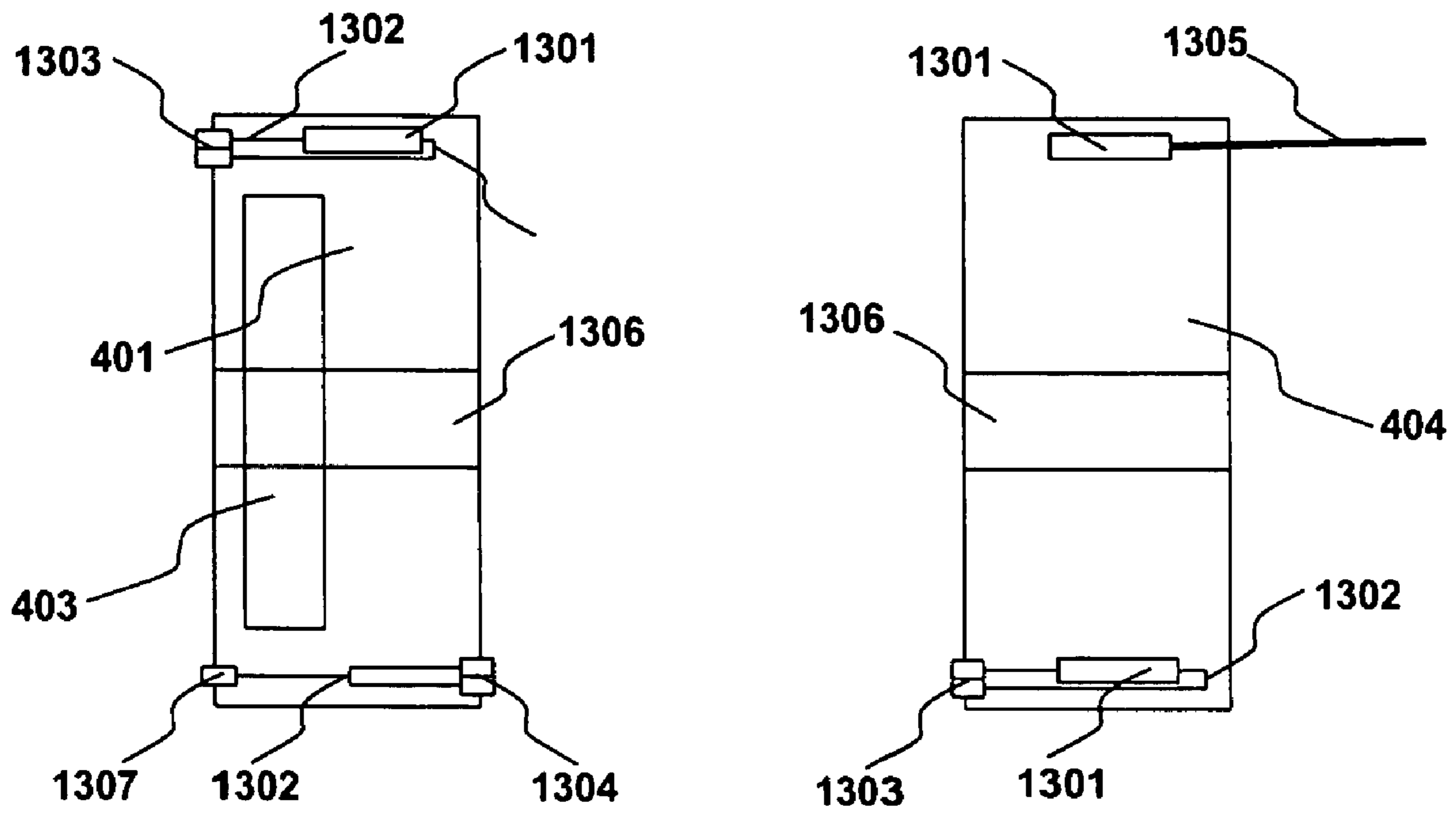

*Fig. 13*



*Fig. 14*

## MODULAR RAIL COVER

## TECHNICAL FIELD

Embodiments relate to the fields of small arms, rifle hand-  
guards, carbine handguards, and mounting rails.

## BACKGROUND

Current small arms use mounting rail systems for attaching  
accessories to the small arm. For example, M4 and M16  
carbines are often fitted with handguards that incorporate up  
to four Picatinny rails. Picatinny rails are well known mount-  
ing rails that meet the specifications contained in MIL-STD-  
1913 and MIL-STD-1913 Notice 1. Another mounting rail  
called the Weaver rail is a notoriously well known variation of  
the Picatinny rail. Battaglia discloses a mounting rail system  
in U.S. Pat. No. 6,792,711 while Olson discloses another in  
U.S. Pat. No. 5,826,363.

FIG. 1, labeled as “prior art”, illustrates a handguard **101**  
with four mounting rails **102** of which three are visible. A  
number of accessories have been developed to attach to small  
arms by way of mounting rails **102**. The mounting rails have  
recoil grooves **103** that help lock accessories in place and help  
users attach accessories in repeatable positions.

FIG. 2, labeled as “prior art”, illustrates an M16 rifle **201**  
with mounting rails **102**. The specific rifle is a flat top model  
having a mounting rail **102** on the upper receiver **202** as well  
as the four on the handguard. Some other models have upper  
receivers with carrying handles and integral rear sights. The  
illustrated firearm has a total of five mounting rails. It is  
unlikely to find a firearm provisioned with enough accesso-  
ries to populate every inch of all five mounting rails **102**.  
Furthermore, the handguard **101** is intended to be held by a  
person’s hand. The mounting rails **102** on the handguard **101**  
can be extremely uncomfortable to hold with a bare hand and  
can even cause cuts. The recoil grooves **103** also provide an  
excellent place for mud and other things to collect.

FIG. 3, labeled as “prior art”, illustrates a Picatinny type  
mounting rail **102** viewed from the side. As discussed above  
the mounting rail has recoil grooves **103** that can help lock rail  
mounted accessories in place.

Rail covers, such as those disclosed by Hines (U.S. Pat. No.  
6,725,594) can be attached to the mounting rails so that the  
mounting rails are comfortable to grab and so that the recoil  
grooves do not collect filth. Knight’s Armament of Vero  
Beach, Fla. manufactures rail covers that attach to specially  
designed mounting rails. The specially designed mounting  
rails have rail cover lock points as well as the recoil grooves  
of Picatinny style mounting rails.

Toy replica firearms such as Airsoft toys are pellet firing  
small arms replicas. Hobbyists enjoy engaging in mock non-  
lethal battles using toy replica firearms because they are real-  
istic looking and fire non lethal, although often painful, pel-  
lets. The realistic toys are also used in small arms training  
because the toys can have the same weight, size, and acces-  
sories as firearms used in combat or police work. The toy  
replica firearms are often realistic enough that many acces-  
sories and rail covers can be attached to small arms and to toy  
replica firearms. Those practiced in combat training and  
police training are familiar with toy replica firearms.

Rail covers can be designed to fit, or cut to fit, specific  
mounting rails. Cut to fit rail covers are prone to slipping  
around on the mounting rail and occasionally slipping off.  
Designed to fit rail covers are not suitable for all situations. As  
such, systems and methods are needed to address shortcom-  
ings in the prior art.

## BRIEF SUMMARY

The following summary is provided to facilitate an under-  
standing of some of the innovative features unique to the  
embodiments and is not intended to be a full description. A  
full appreciation of the various aspects of the embodiments  
can be gained by taking the entire specification, claims, draw-  
ings, and abstract as a whole.

Systems and methods providing a modular rail cover that  
fixedly attaches to standard mounting rails is needed.

It is therefore an aspect of the embodiments to provide a  
rail cover module that has a recoil socket. The rail cover  
module can be placed on a mounting rail such that the recoil  
socket aligns with a recoil groove. A recoil plug can then be  
inserted into the recoil socket to fix the rail cover module in  
place. Once fixed in place, the rail cover module is not free to  
slide around on the mounting rail. It is advantageous for the  
recoil plug to snap into place when pressed into the recoil  
socket.

A rail cover section is, essentially, a rail cover module  
without a recoil socket. A rail cover section has a section  
coupler that can attach to a module coupler incorporated into  
the modular rail cover. As such, a rail cover module can be  
fixed in place on the mounting rail and a rail cover section can  
be placed on the mounting rail and fixed to the modular rail  
cover. In this manner, the rail cover section is also fixed in  
place on the mounting rail. Section couplers can also be used  
to attach rail cover sections to one another.

## BRIEF DESCRIPTION OF THE DRAWINGS

The accompanying figures, in which like reference numer-  
als refer to identical or functionally similar elements through-  
out the separate views and which are incorporated in and form  
a part of the specification, further illustrate the present inven-  
tion and, together with the background of the invention, brief  
summary of the invention, and detailed description of the  
invention, serve to explain the principles of the present inven-  
tion.

FIG. 1, labeled as “prior art”, illustrates a handguard with  
four mounting rails of which three are visible;

FIG. 2, labeled as “prior art”, illustrates an M16 rifle with  
mounting rails;

FIG. 3, labeled as “prior art”, illustrates a Picatinny type  
mounting rail viewed from the side;

FIG. 4 illustrates a side view of a mounting rail with a rail  
cover module and a rail cover section in accordance with  
aspects of the embodiments;

FIG. 5 illustrates a top view of a mounting rail with a rail  
cover module and a rail cover section in accordance with  
aspects of the embodiments;

FIG. 6 illustrates a top view of a rail cover module in  
accordance with aspects of the embodiments;

FIG. 7 illustrates a recoil plug in accordance with aspects  
of the embodiments;

FIG. 8 illustrates a top view of a rail cover module with a  
recoil plug in accordance with aspects of the embodiments;

FIG. 9 illustrates a side view of a rail cover module with a  
recoil plug in accordance with aspects of the embodiments;

FIG. 10 illustrates a rail cover module and rail cover sec-  
tions in accordance with aspects of the embodiments;

FIG. 11 illustrates a rail cover module and a rail cover  
section in accordance with aspects of the embodiments;

FIG. 12 illustrates a curved rail cover module and a curved  
recoil plug in accordance with aspects of the embodiments;



3

FIG. 13 illustrates a top view of a rail cover module and a rail cover section with switches and accessory grooves in accordance with aspects of certain embodiments; and

FIG. 14 illustrates an end view of a rail cover module with an accessory groove in accordance with aspects of certain 5 embodiments.

#### DETAILED DESCRIPTION

The particular values and configurations discussed in these non-limiting examples can be varied and are cited merely to 10 illustrate at least one embodiment and are not intended to limit the scope thereof. In general, the figures are not to scale.

A modular rail cover can have rail cover modules and rail cover sections that can be snapped onto or slid onto a mounting rail. Rail cover modules have recoil sockets into which recoil plugs are inserted. The recoil plugs engage recoil 15 grooves such as those in Picatinny type mounting rails to fix the rail cover modules into position. The rail cover sections have section couplers that engage corresponding module couplers on the rail cover modules. The section couplers and module couplers lock rail cover sections to rail cover modules. Section couplers can also lock rail cover sections to one another.

FIG. 4 illustrates a side view of a mounting rail 102 with a rail cover module 401 and a rail cover section 404 viewed from the side in accordance with aspects of the embodiments. The rail cover module 401 can be slid onto or snapped onto the mounting rail 102 and the recoil socket 402 can be aligned with one of the recoil grooves 103. A recoil plug 403 can then 25 be pressed into the recoil socket 402 until it engages the recoil groove 103. The recoil plug 403 locks the rail cover module 401 in place on the mounting rail 102.

A rail cover section 404 can also be slid or snapped onto the mounting rail 102. The main difference between a rail cover section 404 and a rail cover module 401 is that the rail cover section 404 locks into position by coupling to the rail cover module 401. A rail cover module 401 can have module couplers and a rail cover section 404 can have section couplers. The section couplers and the module couplers fit together 35 such that the rail cover section 404 is fixed to the rail cover module 401.

FIG. 5 illustrates a top view of a mounting rail 102 with a rail cover module 401 and a rail cover section 404 in accordance with aspects of the embodiments. The recoil plug 403 45 has been snapped into the recoil socket 402 to fix the rail cover module 401 and the rail cover section 404 in place on the mounting rail 102. Two parts can be snapped together when they have matching concave and convex spots. For example, a convex spot can be a hemispherical bump and a concave spot can be a hemispherical indent. Pressing the two parts together can cause convex spots to snap into concave spots and thereby snap the parts together. Those skilled in the arts of enclosures or mechanical subassemblies are familiar with parts and subassemblies that snap together.

FIG. 6 illustrates a top view of a rail cover module 401 in accordance with aspects of the embodiments. The rail cover module 401 has a recoil socket 402 with concave spots. The concave spots are not shown because they are on the sidewall of the recoil socket 402. Two concave spots are hinge indents 50 located at hinging points 601 while two other concave spots are latch indents located at latching points 602. A recoil socket can have latch indents and no hinge indents. A latching point is a spot where two parts are intended to be snapped together and then be relatively immobile. A hinging point is a spot where two parts are intended to be snapped together to form a hinge.

4

FIG. 7 illustrates a recoil plug 403 in accordance with aspects of the embodiments. The recoil plug has hinge bumps 701 and latch bumps 702. The recoil plug 403 can be pressed into the recoil socket such that all the bumps snap into their respective indents. Alternatively, the recoil plug can be pressed in the recoil socket on one end so that the hinge bumps 701 engage the hinge indents to form a hinge.

FIG. 8 illustrates a top view of rail cover module 401 with a recoil plug 403 in accordance with aspects of the embodiments. The recoil plug 403 is fully pressed into the recoil socket to form a hinge 801 and to latch the recoil plug 403 in place. A pry point 802 is an indented area where a tool or finger nail can be inserted to pry up the end of the recoil plug 403 and thereby disengage the latch bumps from the latch 15 indents. A recoil plug and recoil socket can be designed to have hinge points on both sides so that unhinging one side allows the recoil plug to hinge on the other side while engaging both sides causes the recoil plug to be latched down into the recoil socket.

FIG. 9 illustrates a side view of rail cover module 401 with a recoil plug 403 in accordance with aspects of the embodiments. The recoil plug 403 is attached to the rail cover module 401 by a hinge, but is not latched down. As such, the rail cover module can be slid on a mounting rail. The recoil plug 403 can 20 be unhinged by pulling it away from the rail cover module 401. The recoil plug 403 as illustrated can also be unhinged by misaligning it to a recoil groove and then pressing down on the end opposite from the hinge. The rail cover module 401 also has module couplers 901.

FIG. 10 illustrates a rail cover module 401 and rail cover sections 404 in accordance with aspects of the embodiments. The module couplers 901 are designed to lock into section couplers 1003. The module couplers 901 can have hemispherical bumps 1002 so that they more firmly lock in place when pressed into the section couplers 1003. Some of the section couplers are holes into which the module couplers can be pressed. The holes are illustrated as tapered although straight sidewalls can also be used. Other section couplers 1001 are similar to the module couplers 901 so that rail cover sections can be joined end to end.

FIG. 11 illustrates a rail cover module 401 and a rail cover section 404 in accordance with aspects of the embodiments. Both the rail cover module 401 and the rail cover section 404 have holes 1102 similar to the section couplers 1003 of FIG. 10. The holes 1102 act as section couplers and as module couplers. The rail cover module 401 and the rail cover section can be joined by pressing them together with connectors 1101 engaging the holes 1102.

FIG. 12 illustrates a curved rail cover module 1201 and a curved recoil plug 1202 section in accordance with aspects of the embodiments. The rail cover modules and recoil plugs of FIGS. 4-11 are idealized to more easily show aspects of the 50 embodiments. Curved rail covers produce a more comfortable hand grip. Curved rail covers can also be snapped onto a mounting rail by pressing them down onto the mounting rail because the curved section flattens and the sides get further apart. As such, a rail cover module 1201 can be snapped onto a mounting rail. A curved recoil plug 1202 matches the curved profile of the curved rail cover module 1201.

FIG. 13 illustrates a top view of a rail cover module 401 and a rail cover section 404 with switches 1301 and accessory grooves 1306 in accordance with aspects of certain embodiments. Switches, connectors, and wires can be attached to or incorporated into rail cover modules 401 or rail cover sections 404. Electrical current or voltage present at a connector 1303 and passing along a wiring path 1302 can be controlled by a 65 switch 1301. Wires 1305 can alternatively be wired directly to

## 5

a switch **1301**. Pass through wiring can accept an electrical current or voltage at a connector **1307** then passes it along a wiring path **1302** to a mating connector **1304**. A mating connector **1304** can connect to a connector **1303** so that a switch **1308** is electrically connected to the connector **1307**. Electrical connections, switches, wires, wiring, and wiring paths are well known to those practiced in the art of electrical circuitry.

Many of the well known switches can be used such as slide switches, rocker switches, and pressure sensitive switches. Pressure sensitive switches are switches that open or close only while pressed.

FIG. **14** illustrates an end view of a rail cover module **401** with an accessory groove **1306** in accordance with aspects of certain embodiments. An accessory groove **1306** can provide an attachment point for accessories having a matching form. For example, the accessory groove can be designed to mate to a Picatinny rail. As can be seen in FIG. **13**, the accessory groove can be formed into the rail cover module **401**, rail cover section **404**, and recoil plug **403**.

It will be appreciated that variations of the above-disclosed and other features and functions, or alternatives thereof, may be desirably combined into many other different systems or applications. Also that various presently unforeseen or unanticipated alternatives, modifications, variations or improvements therein may be subsequently made by those skilled in the art which are also intended to be encompassed by the following claims.

What is claimed is:

**1.** A system comprising:  
a rail cover module comprising a recoil socket; and  
a recoil plug;  
wherein a mounting rail comprises at least one recoil groove; and  
wherein the recoil plug plugs into the recoil socket and engages the at least one recoil groove to fix the rail cover module to the mounting rail.

**2.** The system of claim **1** wherein a firearm comprises the mounting rail.

**3.** The system of claim **2** wherein a hinge engages the recoil plug to the rail cover module such that the recoil plug rotates on the hinge to plug into the recoil socket and engage the recoil groove.

**4.** The system of claim **3** wherein rotating the recoil plug into the recoil socket when the recoil socket and the at least one recoil groove are misaligned disengages the recoil plug from the rail cover module.

**5.** The system of claim **2** wherein pressing the recoil plug into the recoil socket results in the in the recoil plug snapping into position such that the recoil plug cannot freely disengage from the recoil groove.

**6.** The system of claim **2**:  
wherein pressing the recoil plug into the recoil socket results in the in the recoil plug snapping into position;  
wherein the recoil plug cannot freely disengage from the recoil groove when snapped into position; and  
wherein snapping the recoil plug into position forms a hinge connecting the recoil plug to the rail cover module.

## 6

**7.** The system of claim **2** further comprising:  
a module coupler and a rail cover section comprising a section coupler; and  
wherein the module coupler and the section coupler engage to join the rail cover module and the rail cover section end to end.

**8.** The system of claim **1** wherein the mounting rail is a Picatinny rail.

**9.** The system of claim **1** wherein a toy firearm replica comprises the mounting rail.

**10.** A method comprising:  
providing a rail cover module comprising a recoil socket; wherein a mounting rail comprises at least one recoil groove;

wherein inserting a recoil plug into the recoil socket when the recoil socket is aligned to the at least one recoil groove locks the rail cover module in place on the mounting rail.

**11.** The method of claim **10** wherein the mounting rail is a Picatinny rail.

**12.** The method of claim **10** wherein a firearm comprises the mounting rail.

**13.** The method of claim **10** wherein a toy firearm replica comprises the mounting rail.

**14.** The method of claim **10** further comprising:  
providing a rail cover section comprising a section coupler; wherein the rail cover module further comprises a module coupler; and

wherein the module coupler and the section coupler engage to join the rail cover module and the rail cover section end to end.

**15.** The method of claim **14** wherein a hinge engages the recoil plug and the rail cover module such that the recoil plug rotates on the hinge to plug into the recoil socket and engage the recoil groove.

**16.** A system comprising:  
a rail cover module comprising a module coupler;  
a rail cover section comprising a section coupler;  
wherein a mounting rail comprises at least one recoil groove; and

wherein the module coupler and the section coupler engage to join the rail cover module and the rail cover section end to end.

**17.** The system of claim **16** wherein the mounting rail is a Picatinny rail.

**18.** The system of claim **16** wherein a firearm comprises the mounting rail.

**19.** The system of claim **16** wherein a toy firearm replica comprises the mounting rail.

**20.** The system of claim **16** further comprising a recoil plug;

wherein the rail cover module further comprises a recoil socket; and

wherein the recoil plug plugs into the recoil socket and engages the at least one recoil groove to fix the rail cover module to the mounting rail.