



US007550011B2

(12) **United States Patent**
McKay et al.

(10) **Patent No.:** **US 7,550,011 B2**
(45) **Date of Patent:** **Jun. 23, 2009**

(54) **OSTEOGENIC PACKING DEVICE AND METHOD**

(75) Inventors: **William F. McKay**, Memphis, TN (US);
Bradley T. Estes, Durham, NC (US)

(73) Assignee: **Warsaw Orthopedic, Inc.**, Warsaw, IN (US)

(*) Notice: Subject to any disclaimer, the term of this patent is extended or adjusted under 35 U.S.C. 154(b) by 712 days.

(21) Appl. No.: **10/889,655**

(22) Filed: **Jul. 12, 2004**

(65) **Prior Publication Data**

US 2004/0254583 A1 Dec. 16, 2004

Related U.S. Application Data

(62) Division of application No. 10/040,154, filed on Oct. 22, 2001, now Pat. No. 6,780,192.

(60) Provisional application No. 60/242,934, filed on Oct. 24, 2000.

(51) **Int. Cl.**
A61F 2/44 (2006.01)

(52) **U.S. Cl.** **623/17.16**

(58) **Field of Classification Search** 606/76,
606/77; 433/172-176, 201.1; 604/64, 502,
604/518-519

See application file for complete search history.

(56) **References Cited**

U.S. PATENT DOCUMENTS

- 3,867,728 A 2/1975 Stubstad
- 4,004,565 A * 1/1977 Fischer et al. 124/45
- 4,277,184 A * 7/1981 Solomon 366/139
- 4,375,810 A 3/1983 Belykh
- 4,501,269 A 2/1985 Bagby
- 4,518,384 A * 5/1985 Tarello et al. 604/61
- 4,532,661 A * 8/1985 Halpern 623/23.14

- 4,668,295 A * 5/1987 Bajpai 106/690
- 4,736,738 A 4/1988 Lipovsek et al.
- 4,863,476 A 9/1989 Shepperd
- 4,878,915 A 11/1989 Brantigan
- 4,919,666 A 4/1990 Buchhorn
- 4,961,740 A 10/1990 Ray et al.
- 4,992,226 A * 2/1991 Piez et al. 264/109

(Continued)

FOREIGN PATENT DOCUMENTS

DE 4409836 A 9/1995

(Continued)

OTHER PUBLICATIONS

Minns, R.J. "Preliminary Design and Experimental Studies of a Novel Soft Implant for Correcting Sagittal Plane Instability in the Lumbar Spine" *SPINE* vol. 22, No. 16, pp. 1819-1827 (1997).

Primary Examiner—Eduardo C Robert
Assistant Examiner—Nicholas Woodall

(57) **ABSTRACT**

An osteogenic material packing device is used to pack osteogenic material onto a spinal fusion device. The packing device has a cavity defined therein, which is adapted to receive the spinal fusion device. The packing device further includes an access port, which intersects the cavity to receive the osteogenic material. A cannula is coupled to the packing device and an inserter is coupled to the fusion device in order to insert the fusion device into the packing device. Osteogenic material is packed through the access port around the fusion device. The fusion device then is slid through the cannula and inserted in the intervertebral space between adjacent vertebrae.

24 Claims, 16 Drawing Sheets

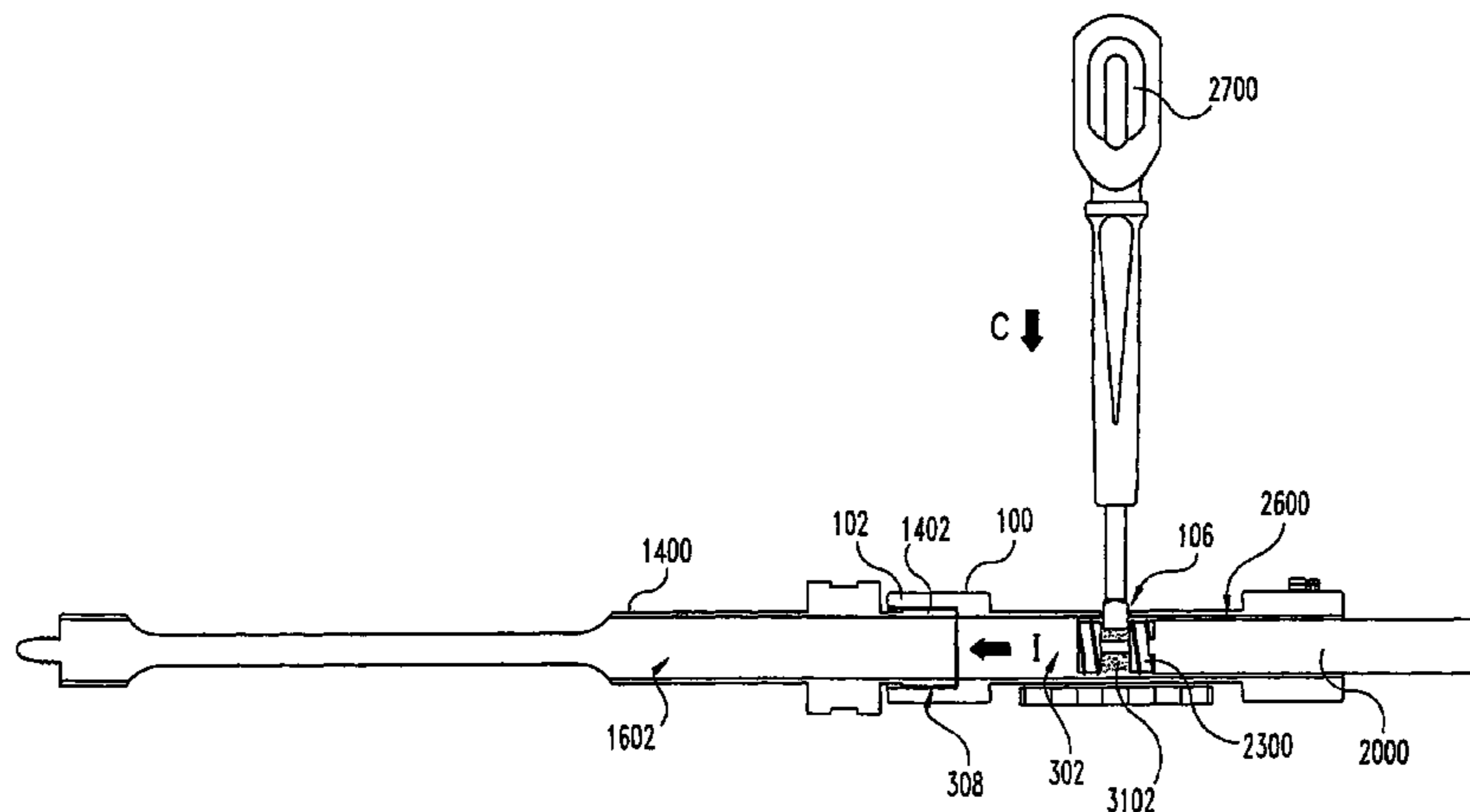

US 7,550,011 B2

Page 2

U.S. PATENT DOCUMENTS

5,015,247 A 5/1991 Michelson
 5,141,510 A 8/1992 Takagi
 5,207,710 A 5/1993 Chu
 5,219,363 A 6/1993 Crowninshield
 5,236,456 A 8/1993 O'Leary et al.
 5,258,029 A 11/1993 Chu
 5,298,254 A 3/1994 Prewett
 5,336,223 A 8/1994 Rogers
 5,348,026 A 9/1994 Davidson
 5,390,683 A 2/1995 Pisharodi
 5,397,364 A 3/1995 Kozak
 5,423,816 A 6/1995 Lin
 5,423,817 A 6/1995 Lin
 5,433,718 A 7/1995 Brinker
 5,443,515 A 8/1995 Cohen
 5,484,410 A * 1/1996 Kriesel et al. 604/89
 5,484,437 A 1/1996 Michelson
 5,489,307 A 2/1996 Kuslich et al.
 5,505,732 A 4/1996 Michelson
 5,507,813 A 4/1996 Dowd et al.
 5,520,923 A 5/1996 Tjia
 5,562,736 A 10/1996 Ray et al.
 5,571,184 A 11/1996 DeSatnick
 5,584,877 A 12/1996 Miyake
 5,584,880 A 12/1996 Martinez
 5,597,897 A * 1/1997 Ron et al. 530/350
 5,618,286 A 4/1997 Brinker
 5,645,591 A 7/1997 Kuberasampath et al.
 5,645,598 A 7/1997 Brosnahan, III
 5,676,699 A 10/1997 Gogolewski
 5,693,100 A 12/1997 Pisharodi

5,709,683 A * 1/1998 Bagby 623/16.11
 5,718,707 A 2/1998 Mikhail
 5,766,253 A 6/1998 Brosnahan
 5,797,909 A 8/1998 Michelson
 5,910,315 A 6/1999 Stevenson et al.
 6,280,474 B1 * 8/2001 Cassidy et al. 623/16.11
 2005/0171554 A1 * 8/2005 Estes et al. 606/104

FOREIGN PATENT DOCUMENTS

EP 0577179 A 1/1994
 EP 0732093 A 9/1996
 EP 0796593 A2 9/1997
 FR 2712486 A 5/1995
 WO WO 91/06266 A 5/1991
 WO WO 91/11148 8/1991
 WO WO 94/07441 4/1994
 WO WO 95/00082 1/1995
 WO WO 95/17861 A 7/1995
 WO WO 92/14423 9/1995
 WO WO 95/25485 A 9/1995
 WO WO 96/27321 9/1996
 WO WO 95/31948 11/1996
 WO WO 96/40014 A 12/1996
 WO WO 97/23174 A 7/1997
 WO WO 97/30666 8/1997
 WO WO 97/37619 10/1997
 WO WO 98/04217 A 2/1998
 WO WO 98/55052 12/1998
 WO WO 99/29271 6/1999
 WO WO 00/42898 7/2000
 WO WO 01/13822 A1 3/2001

* cited by examiner

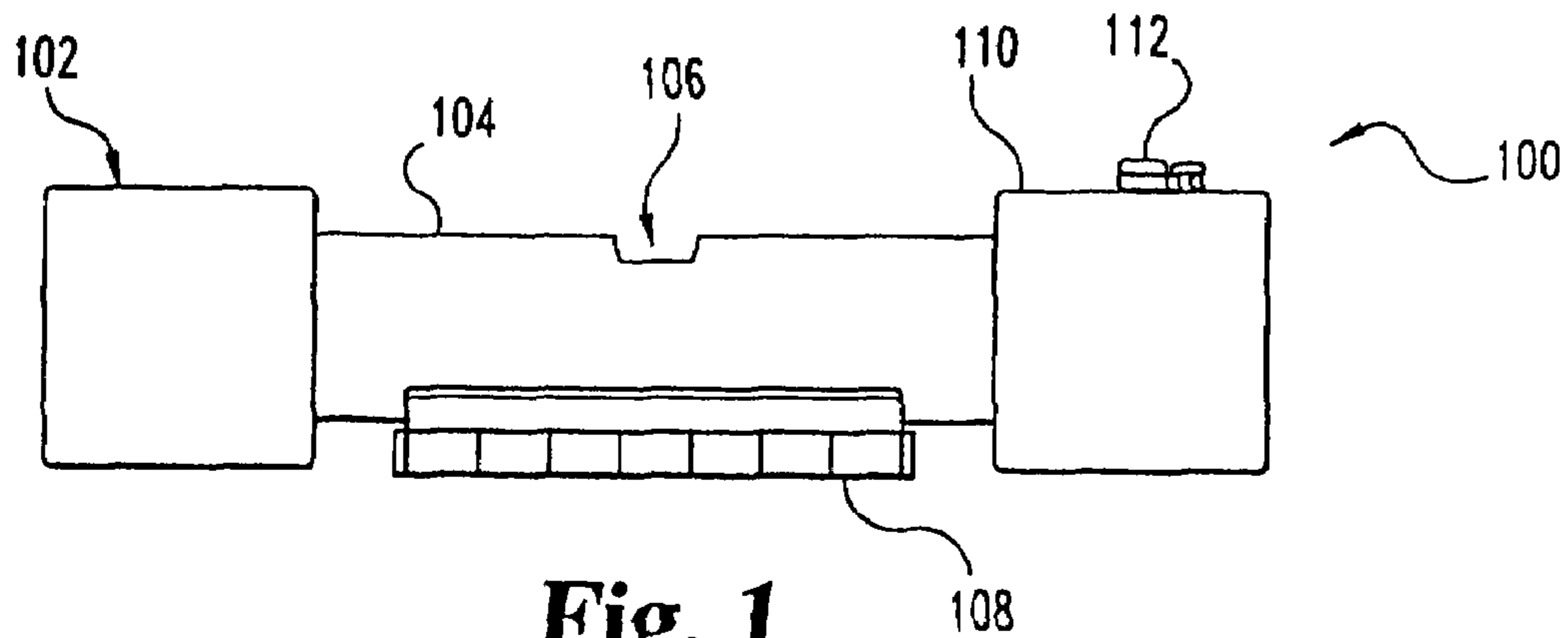

Fig. 1

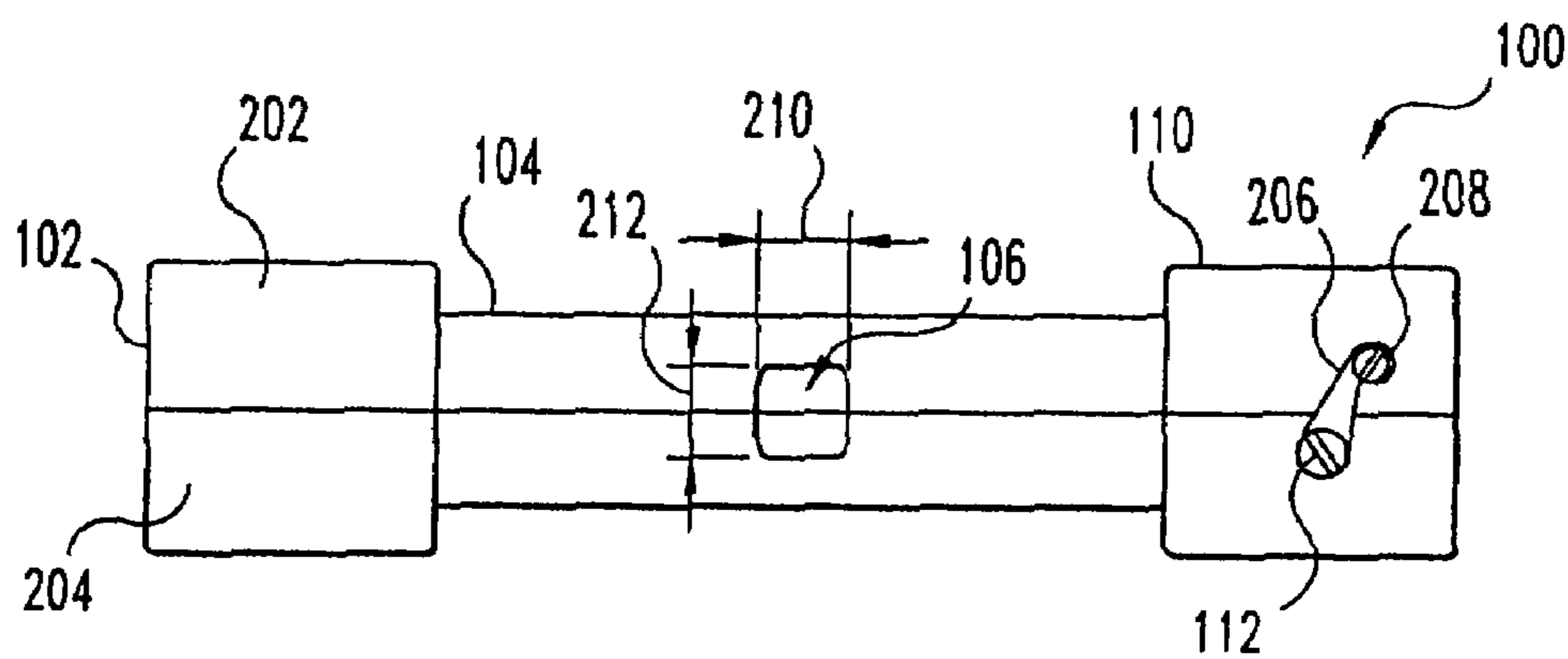

Fig. 2

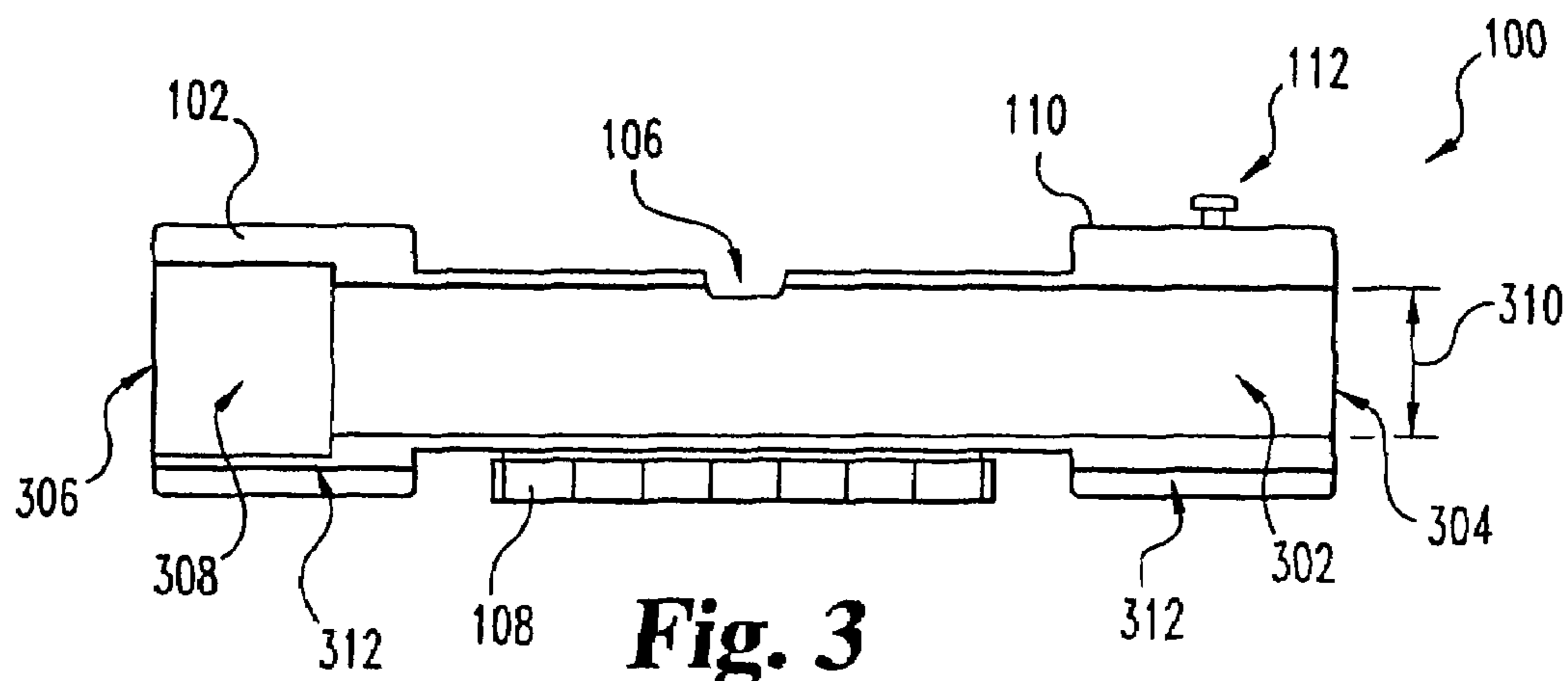

Fig. 3

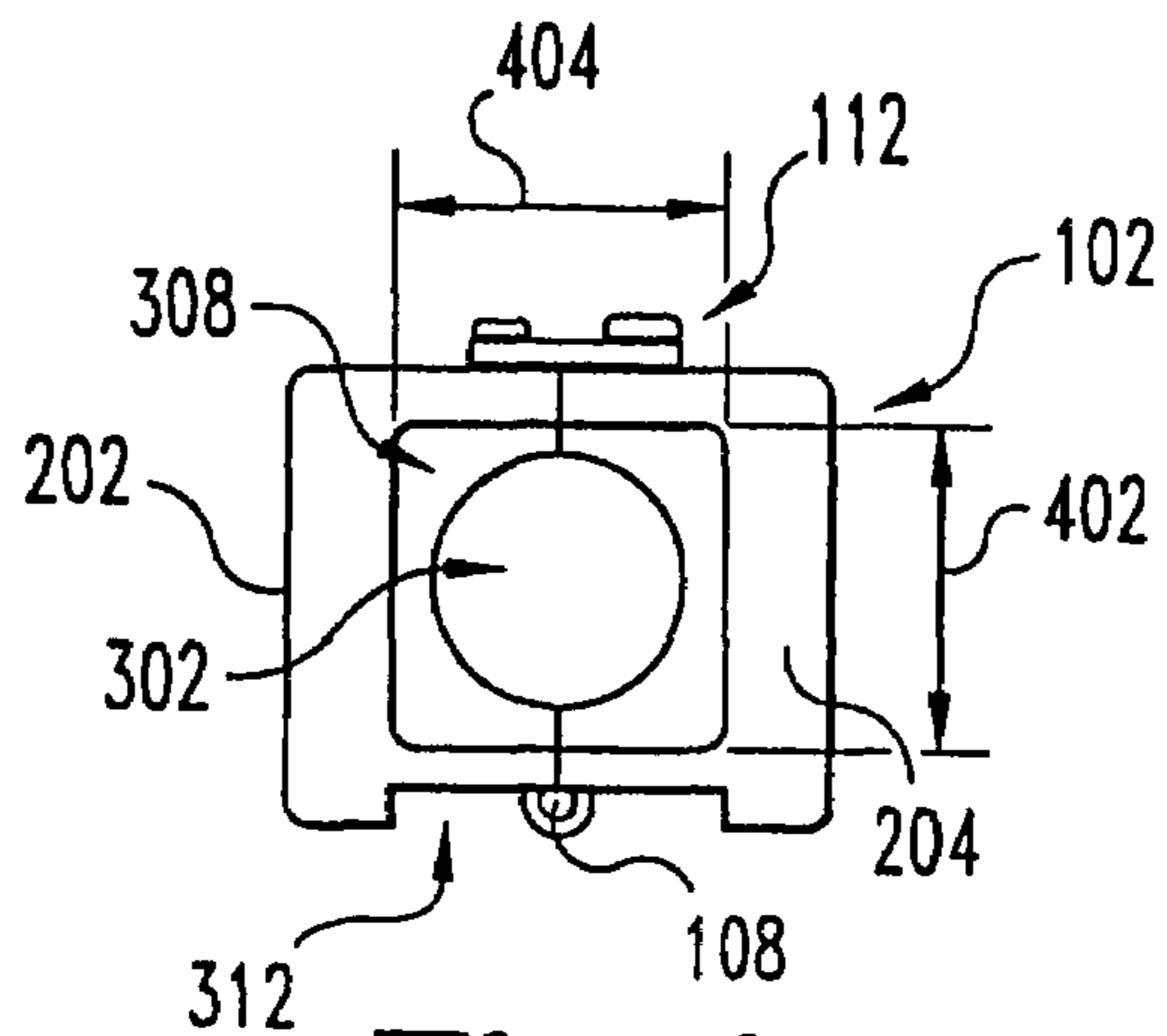

Fig. 4

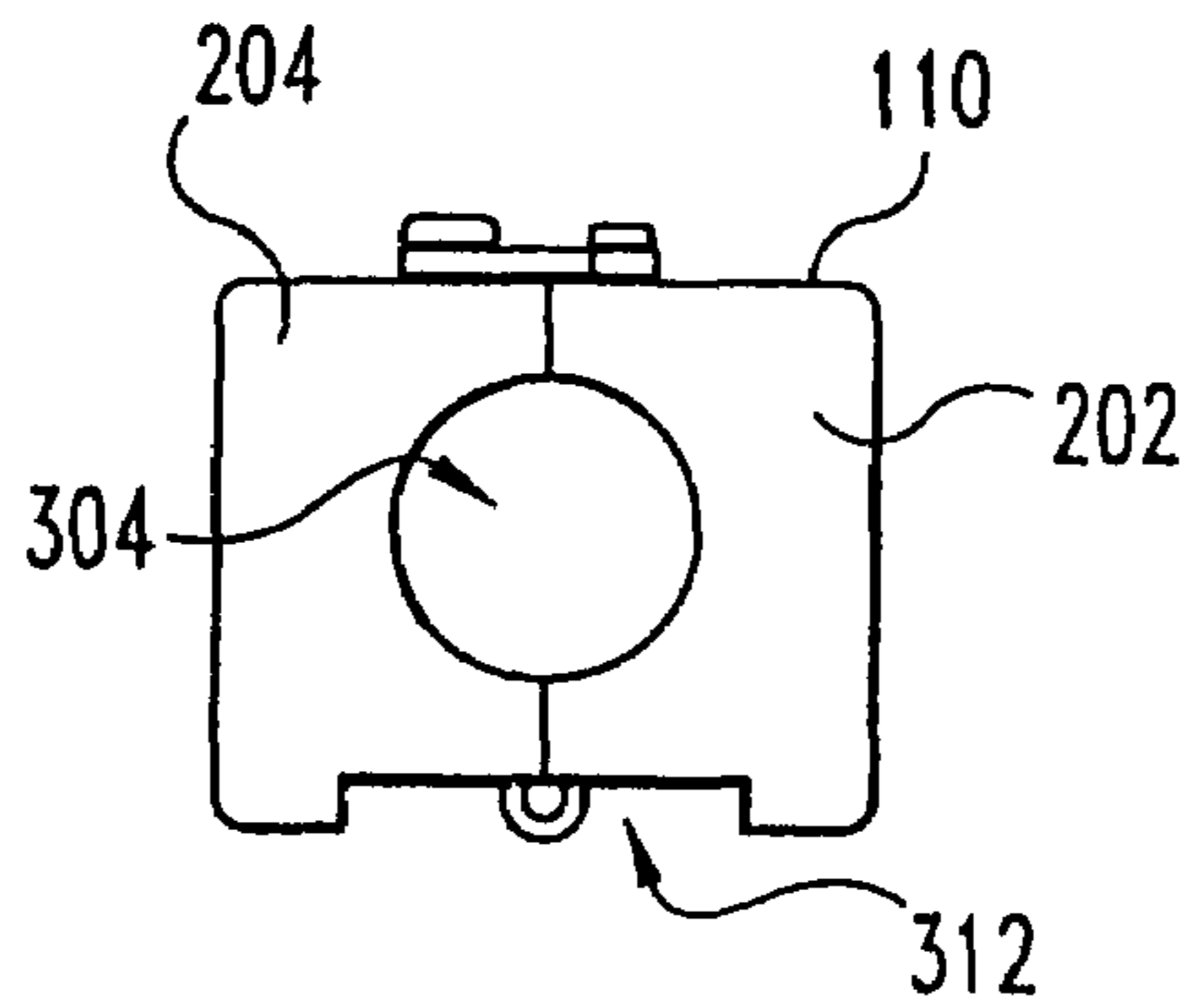

Fig. 5

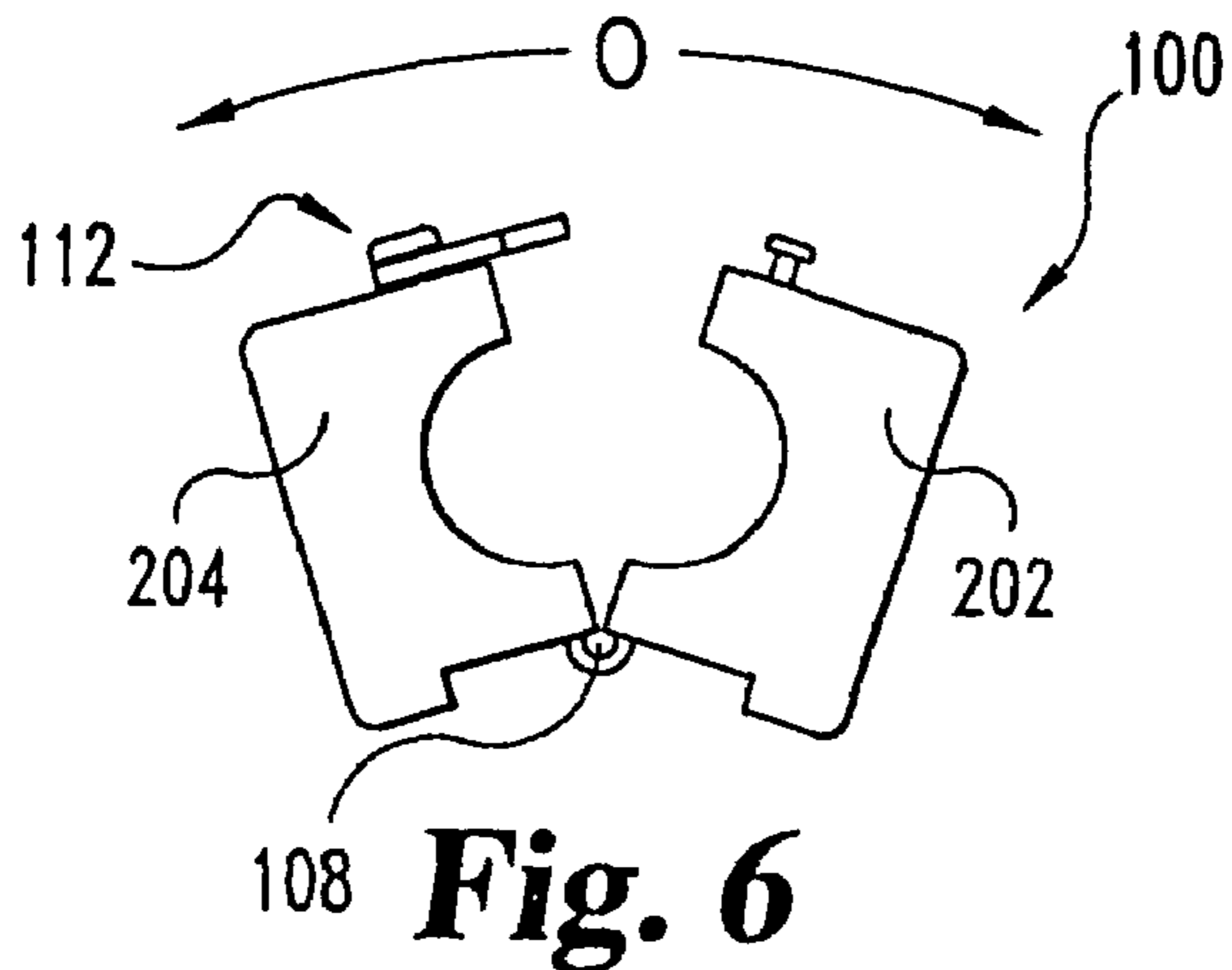

Fig. 6

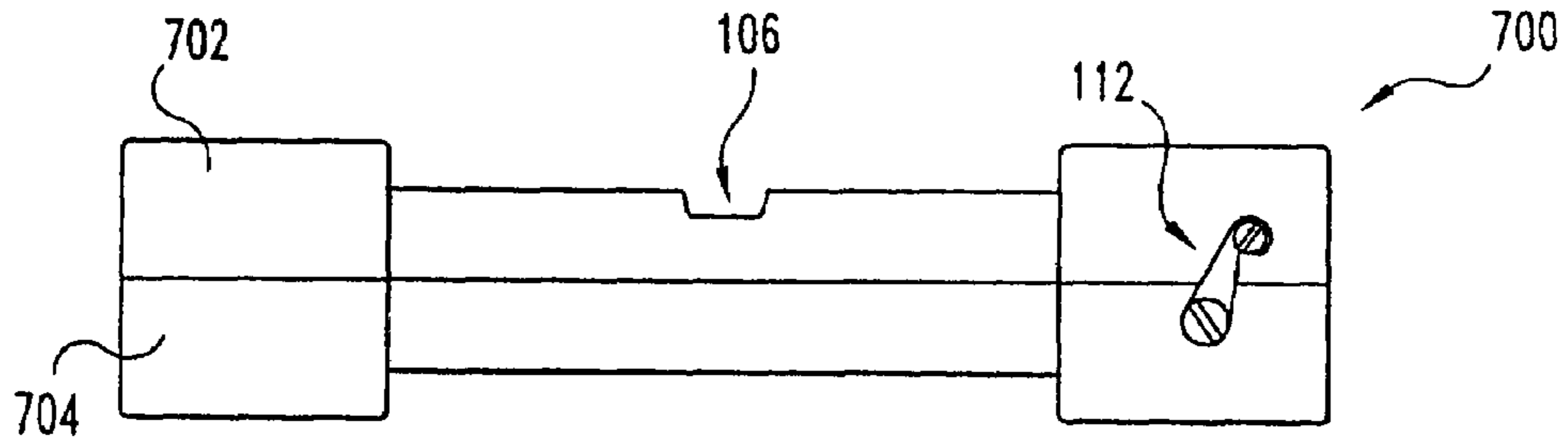

Fig. 7

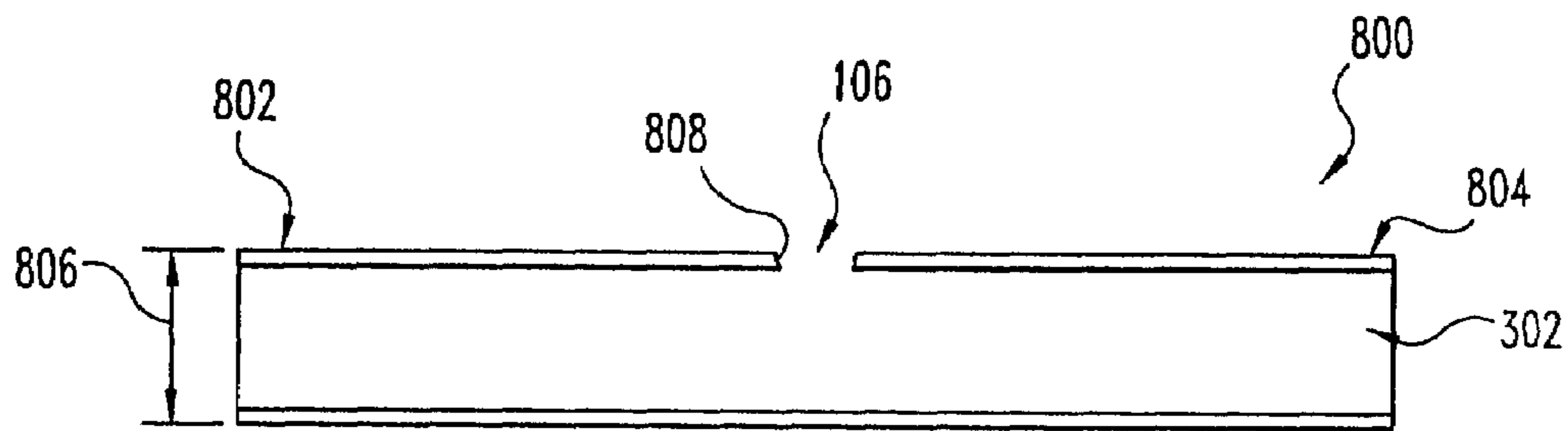

Fig. 8

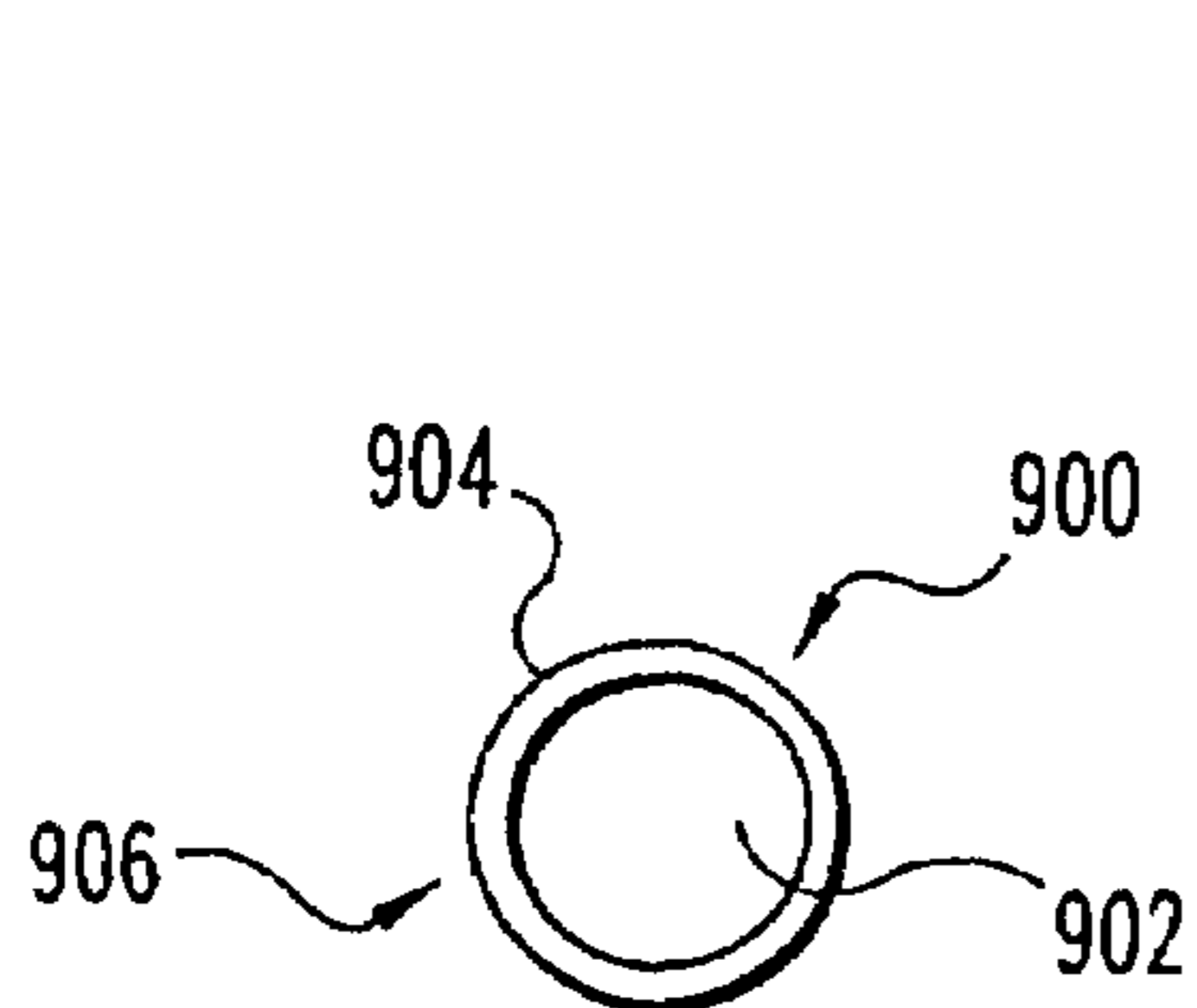

Fig. 9

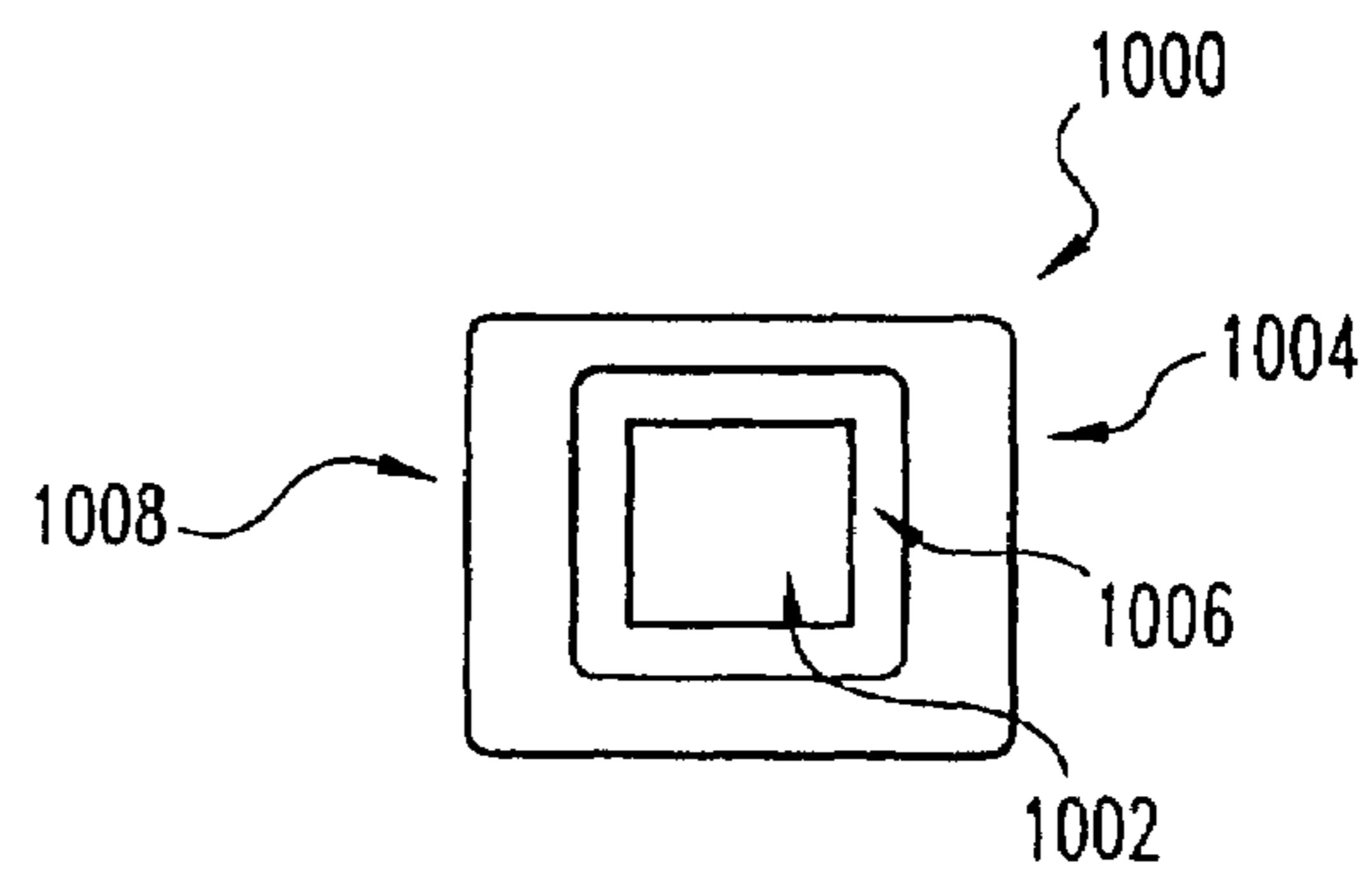

Fig. 10

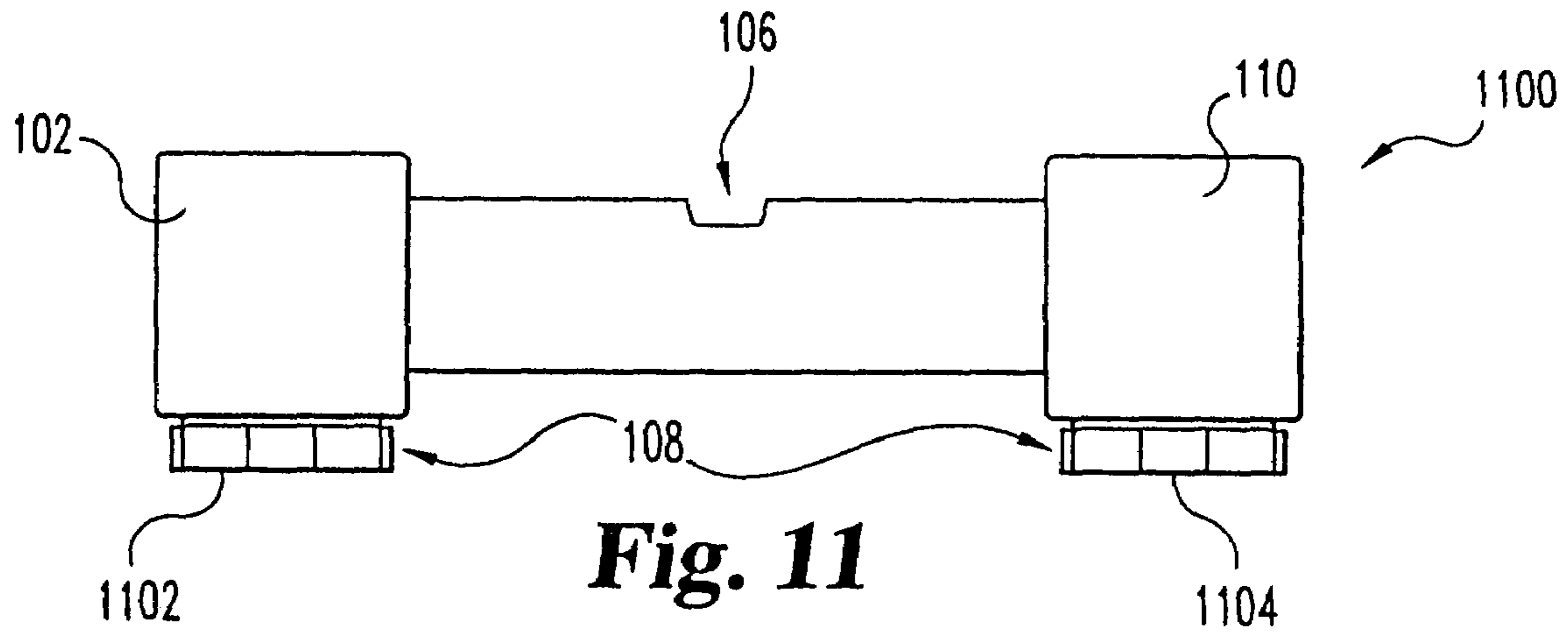

Fig. 11

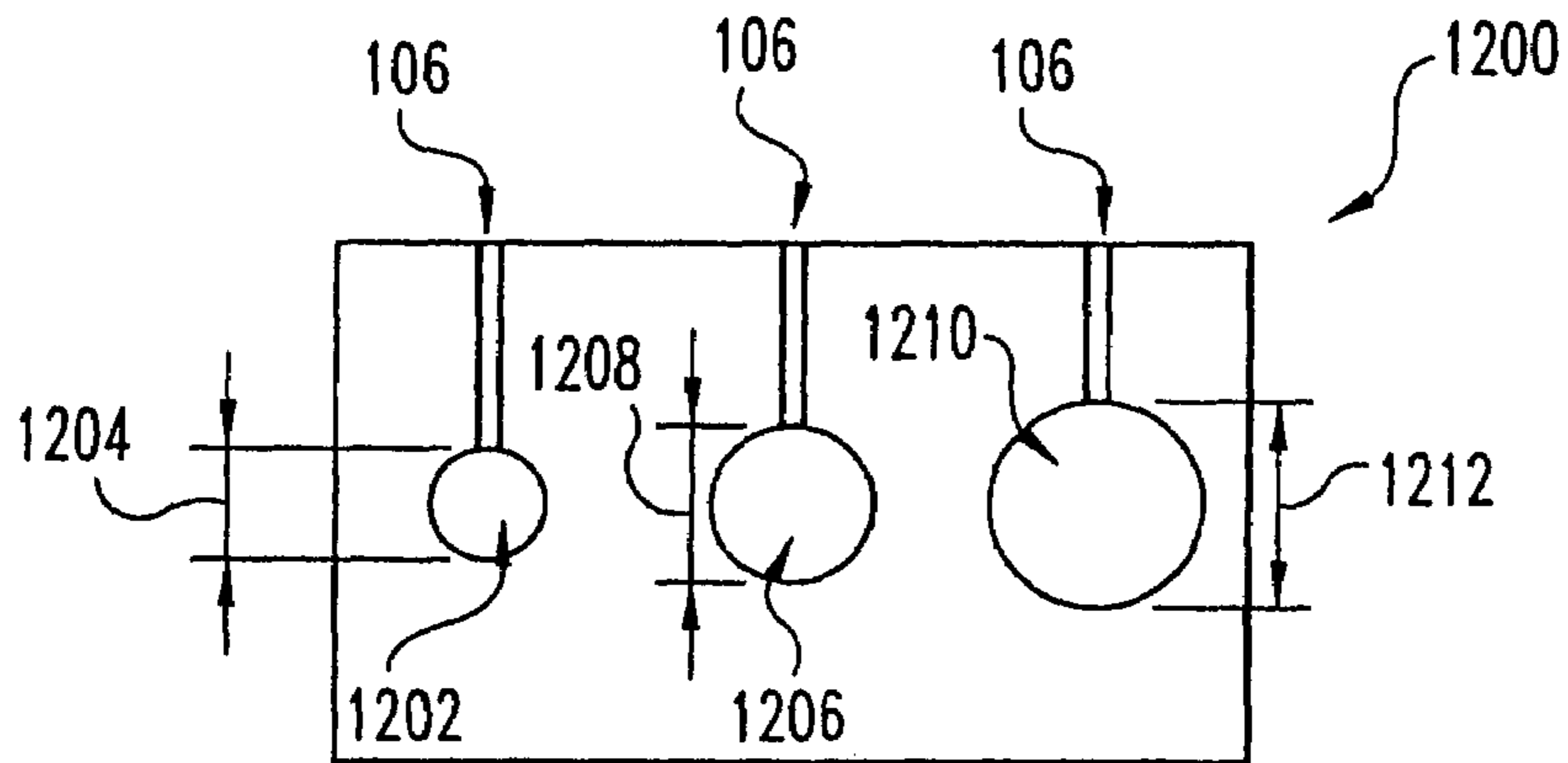

Fig. 12

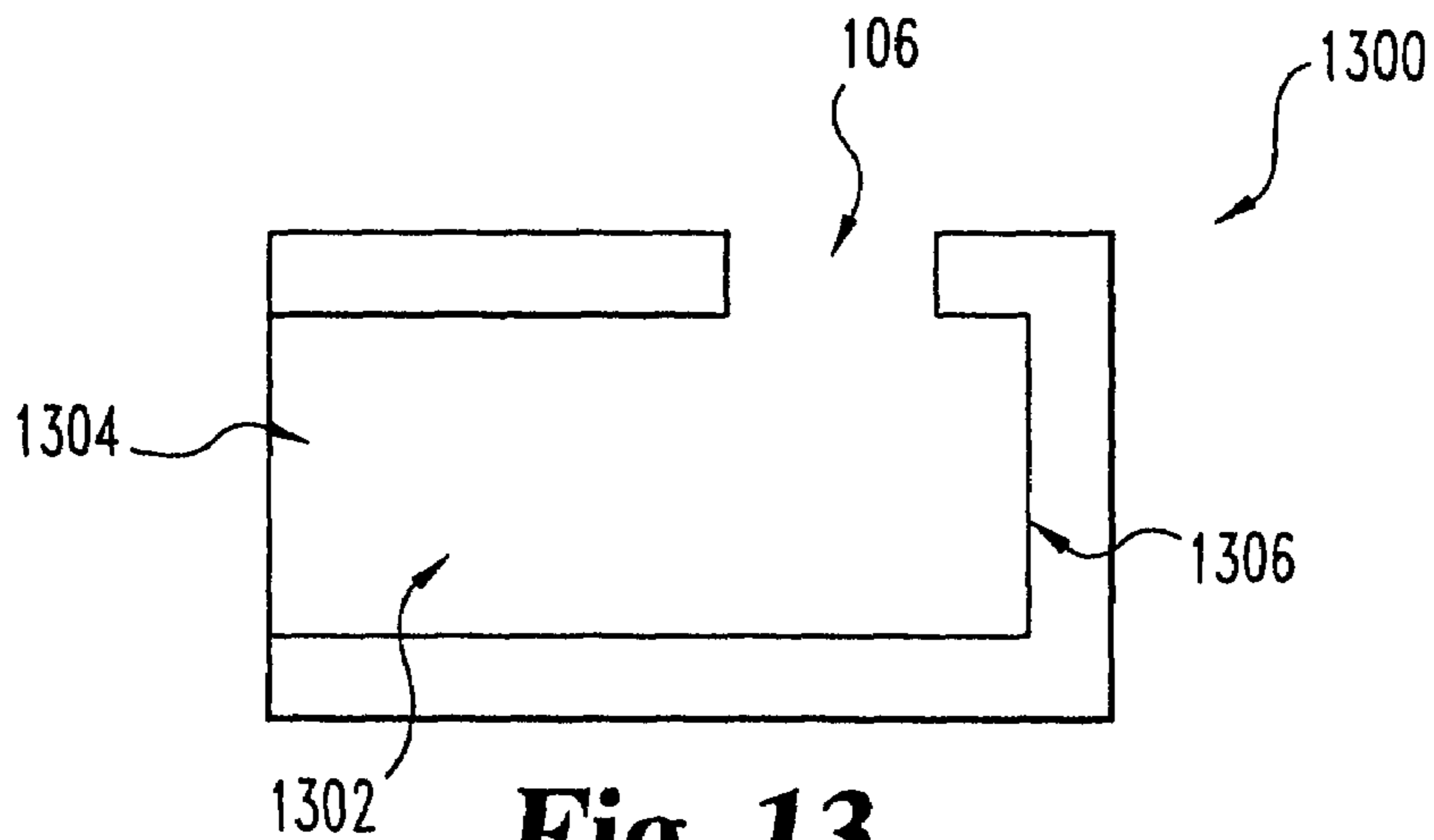

Fig. 13

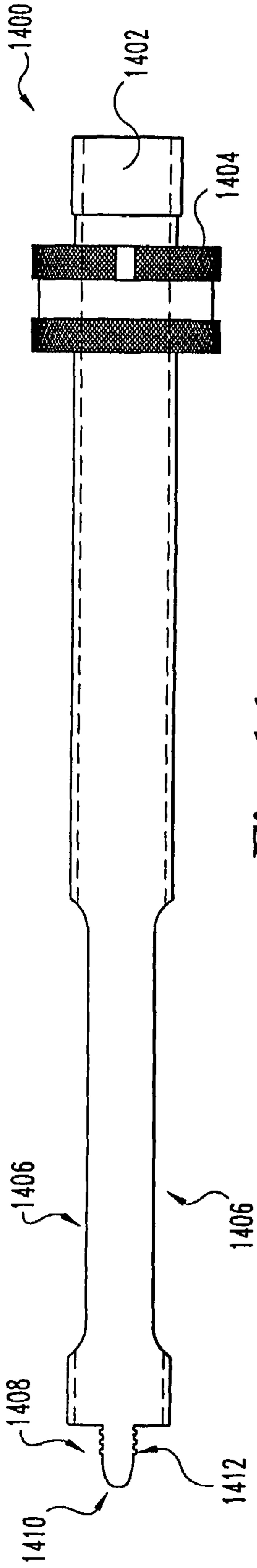

Fig. 14

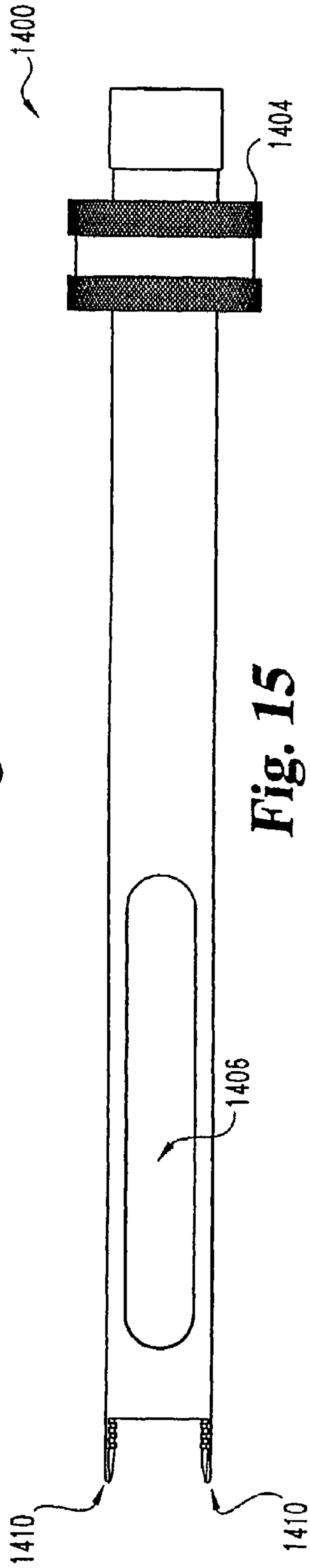

Fig. 15

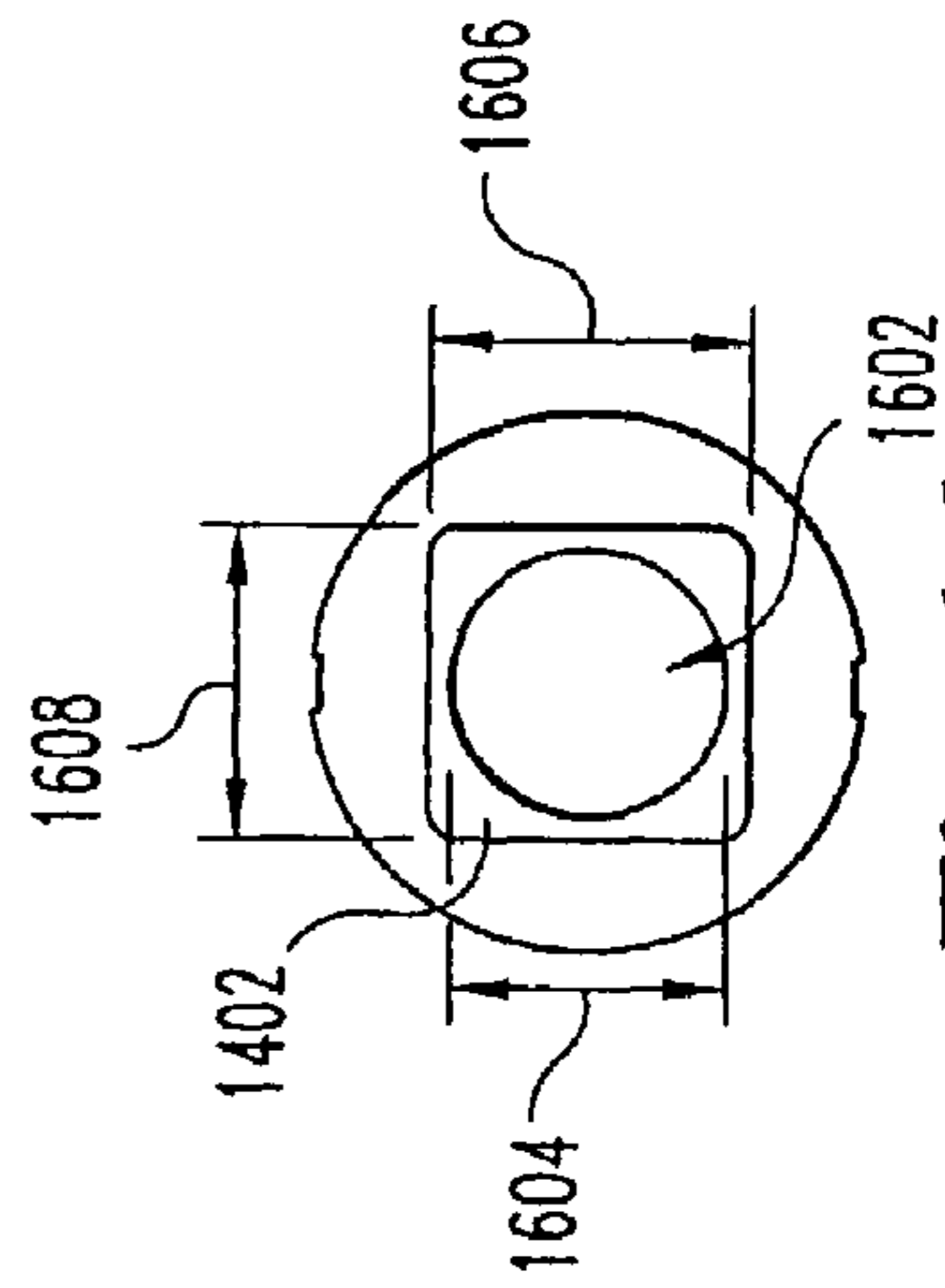

Fig. 16

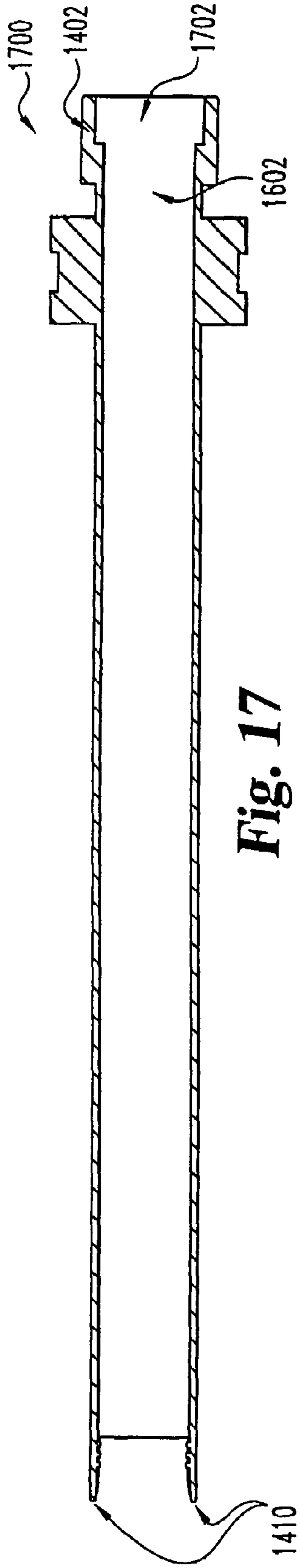

Fig. 17

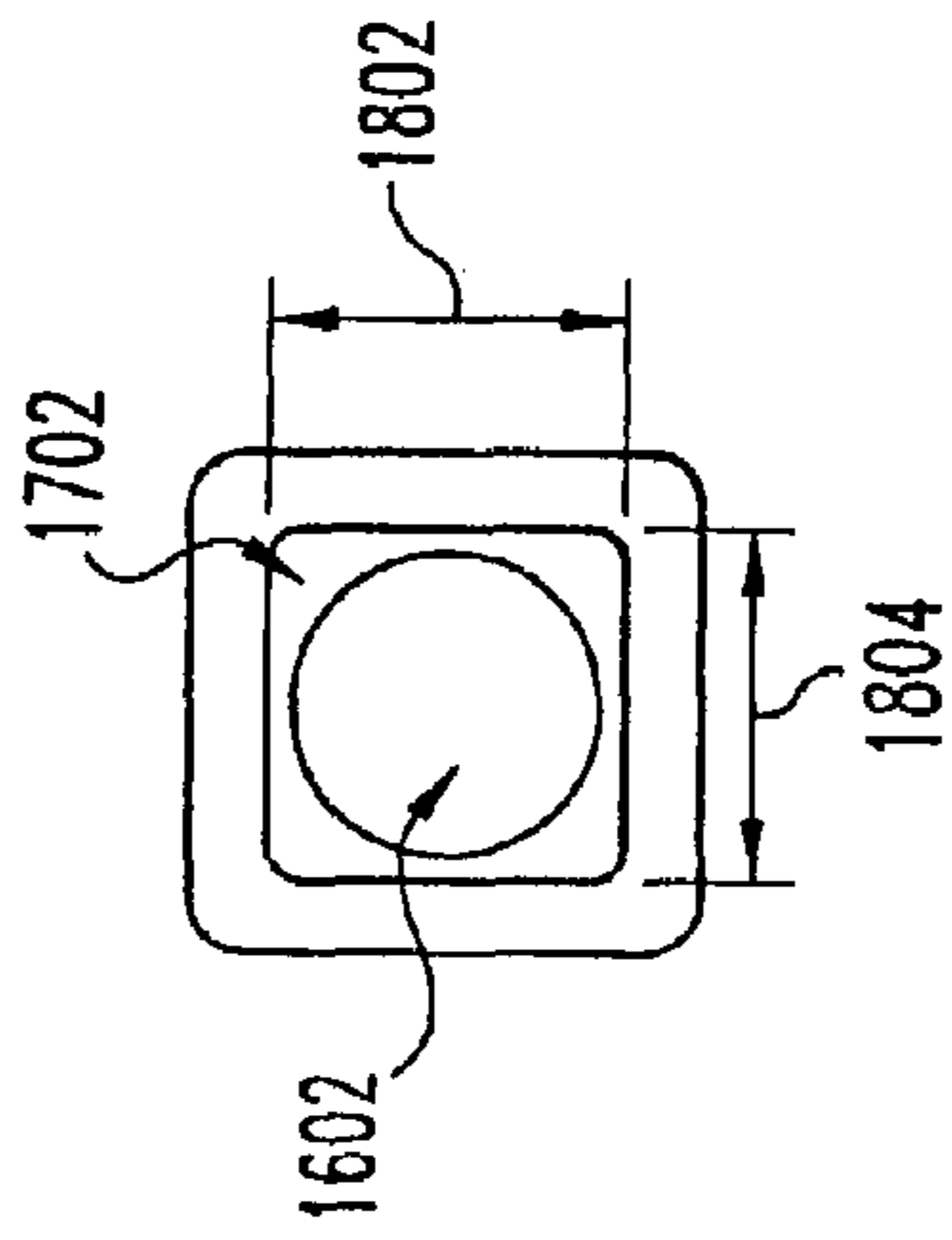

Fig. 18

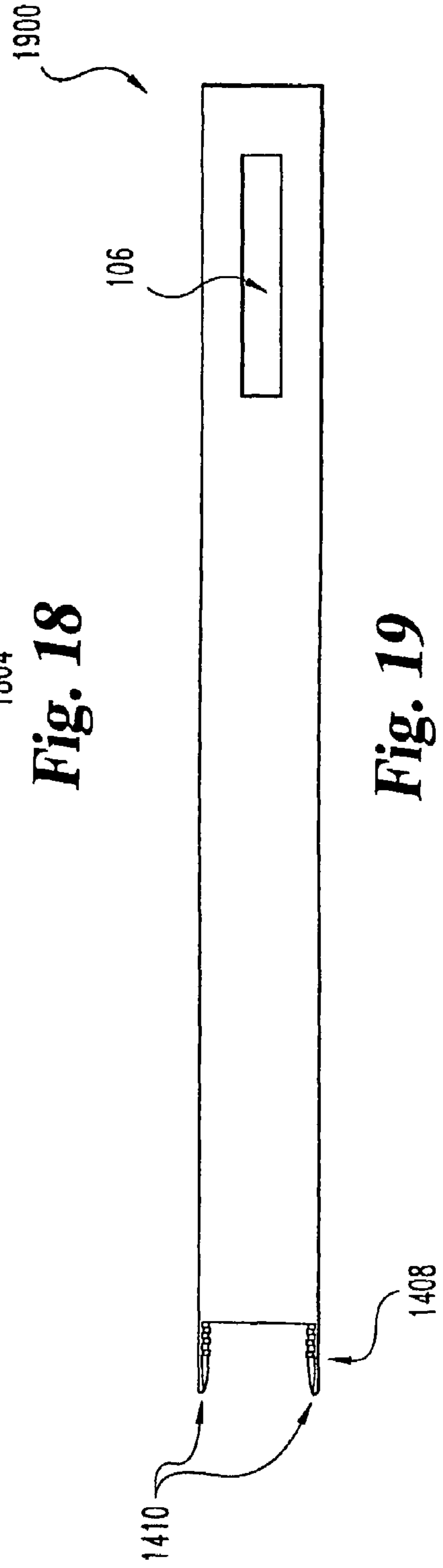

Fig. 19

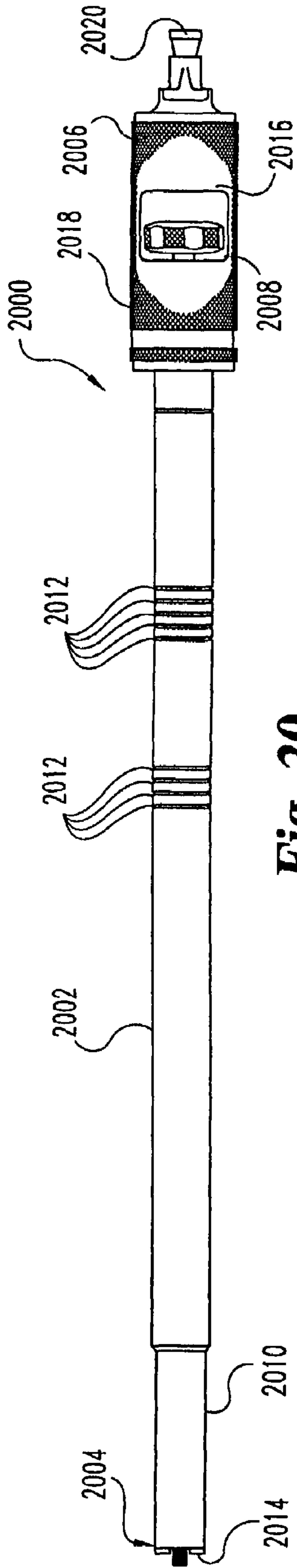

Fig. 20

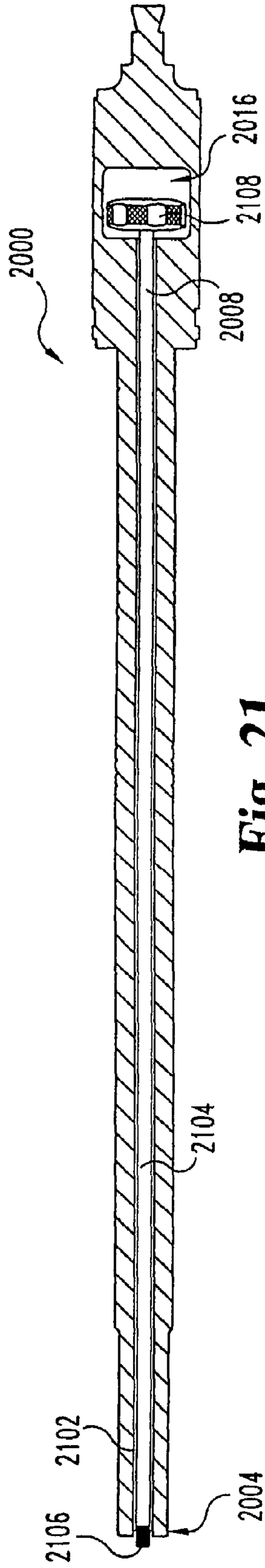

Fig. 21

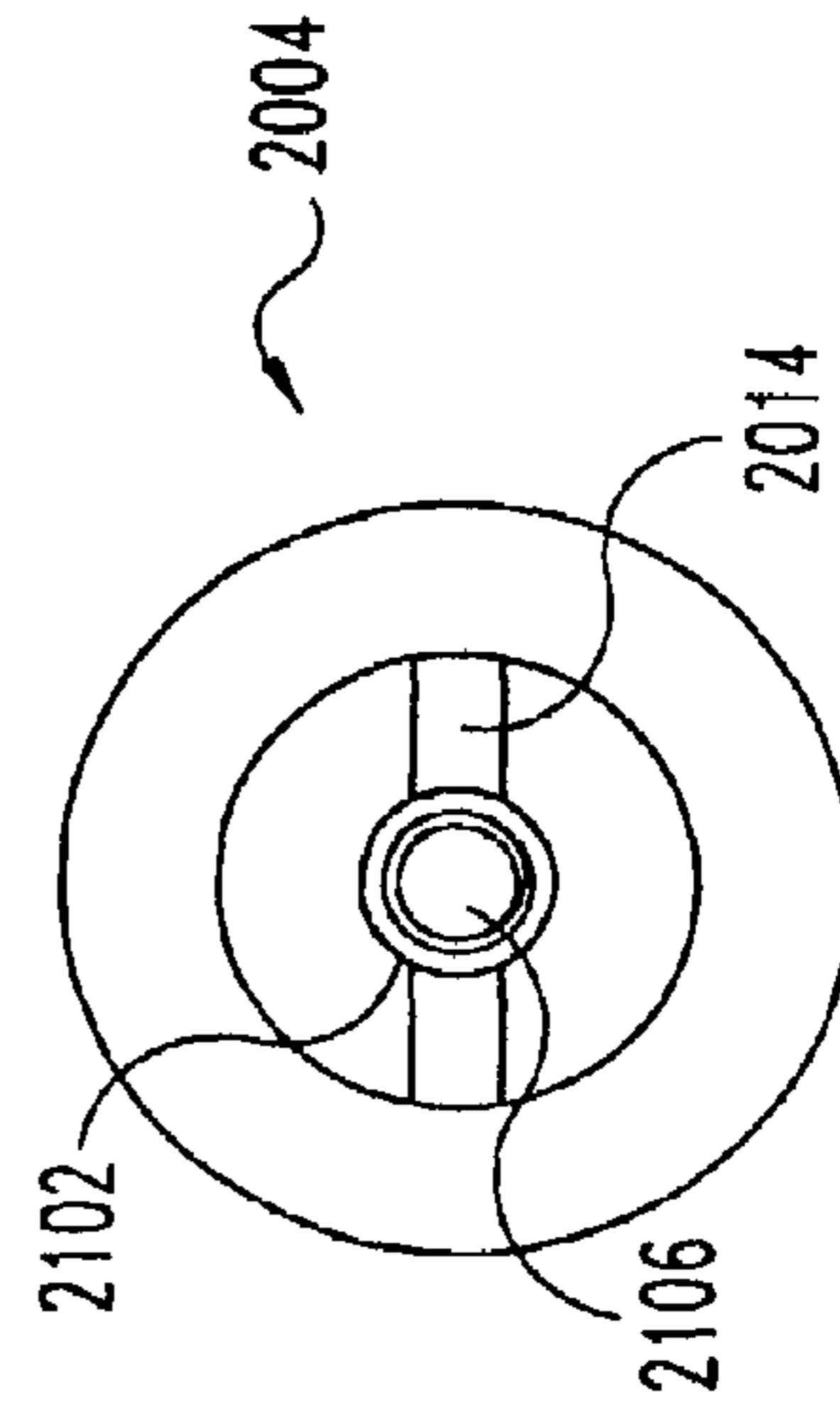

Fig. 22

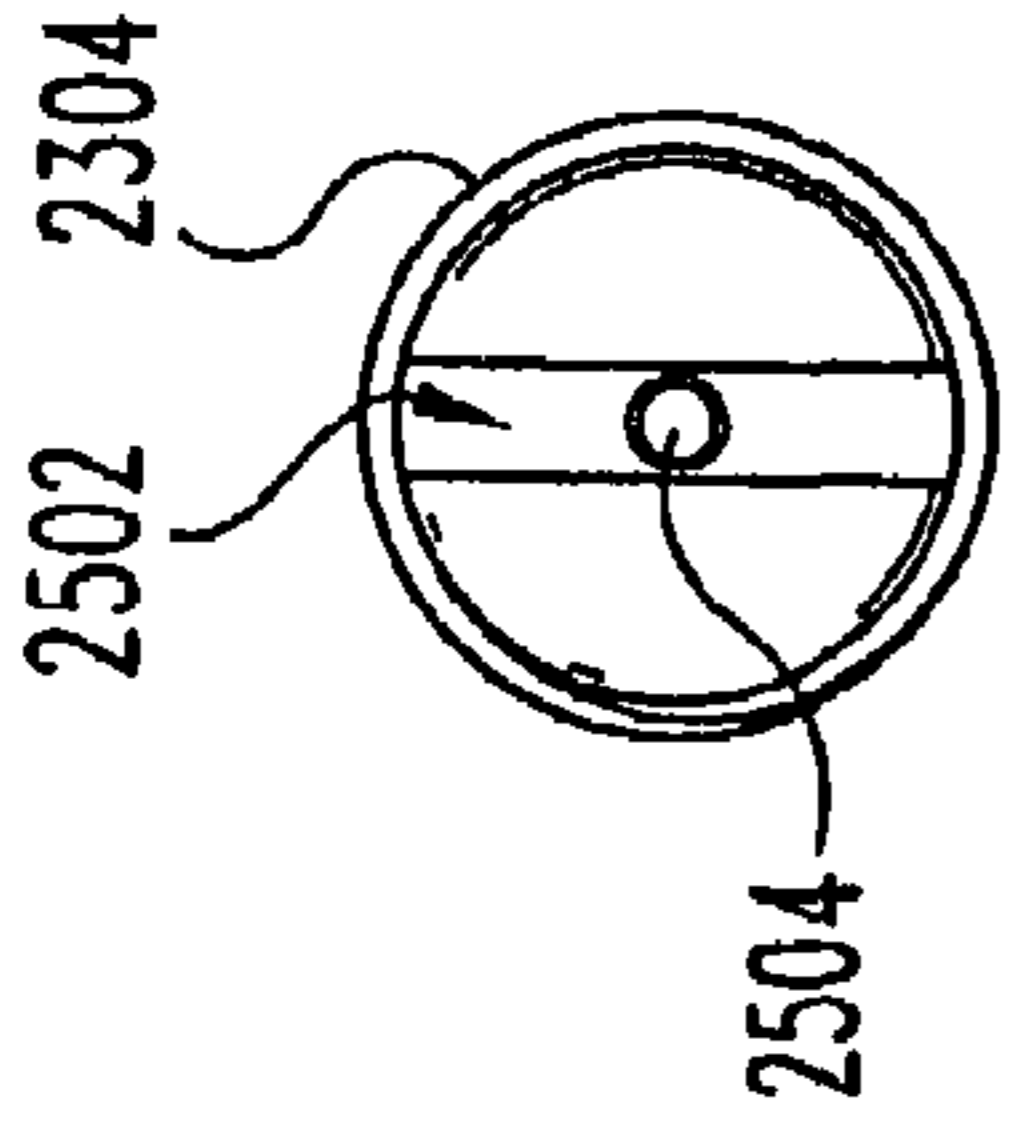

Fig. 23

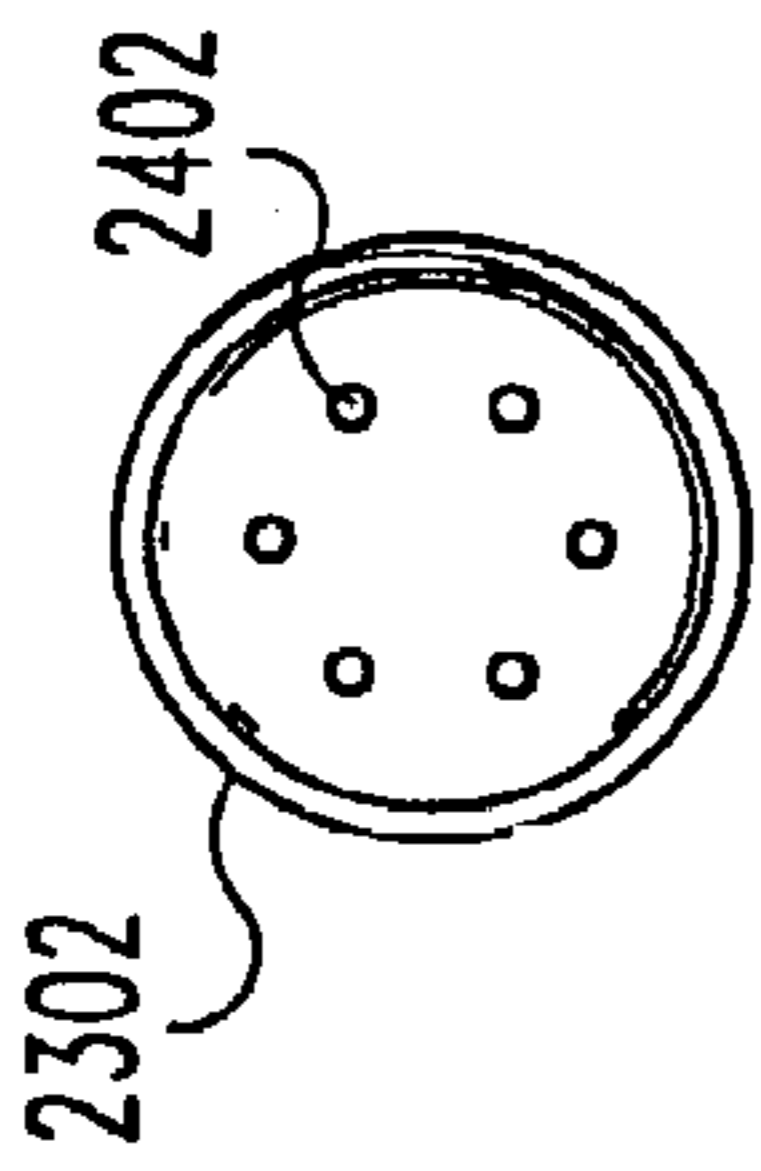

Fig. 24

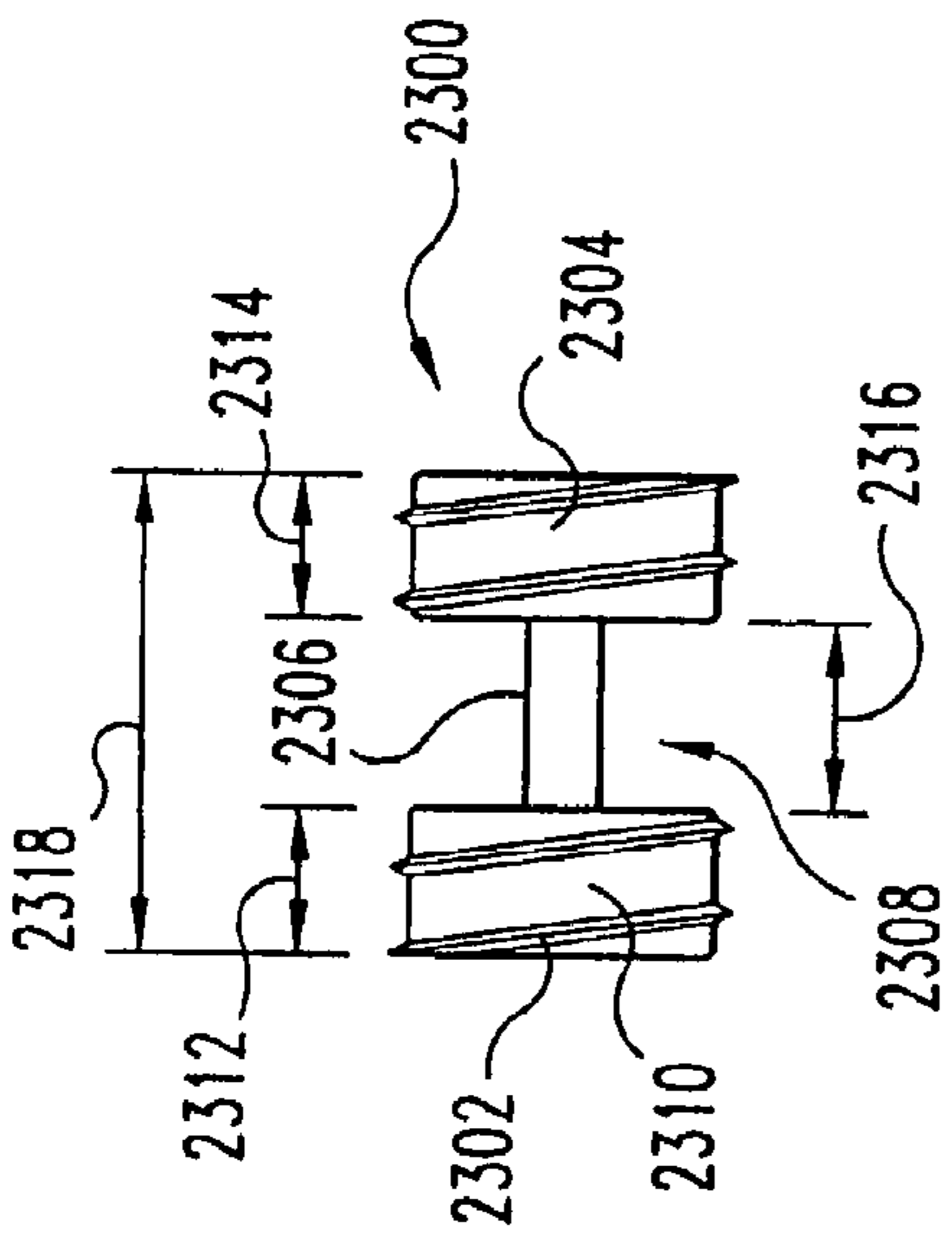

Fig. 25

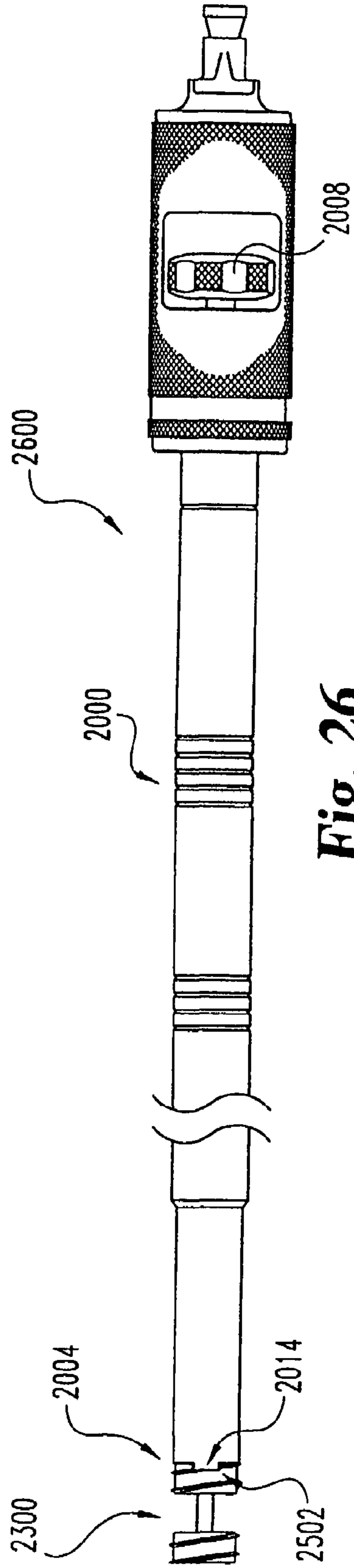

Fig. 26

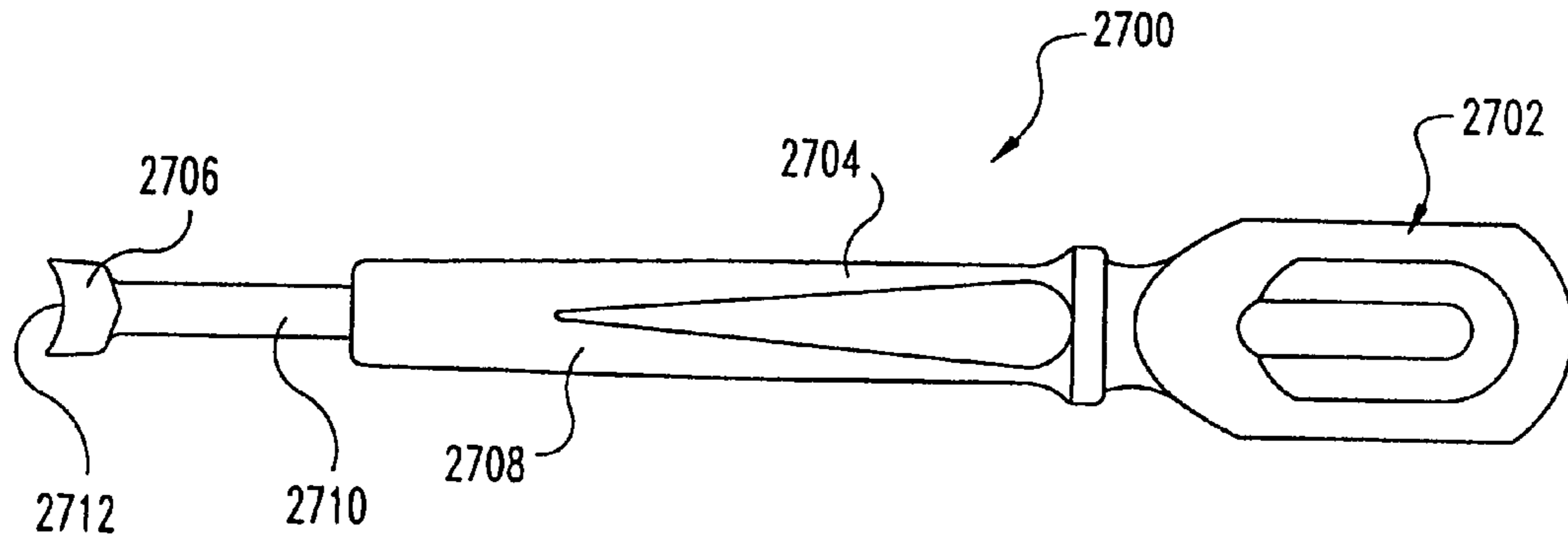

Fig. 27

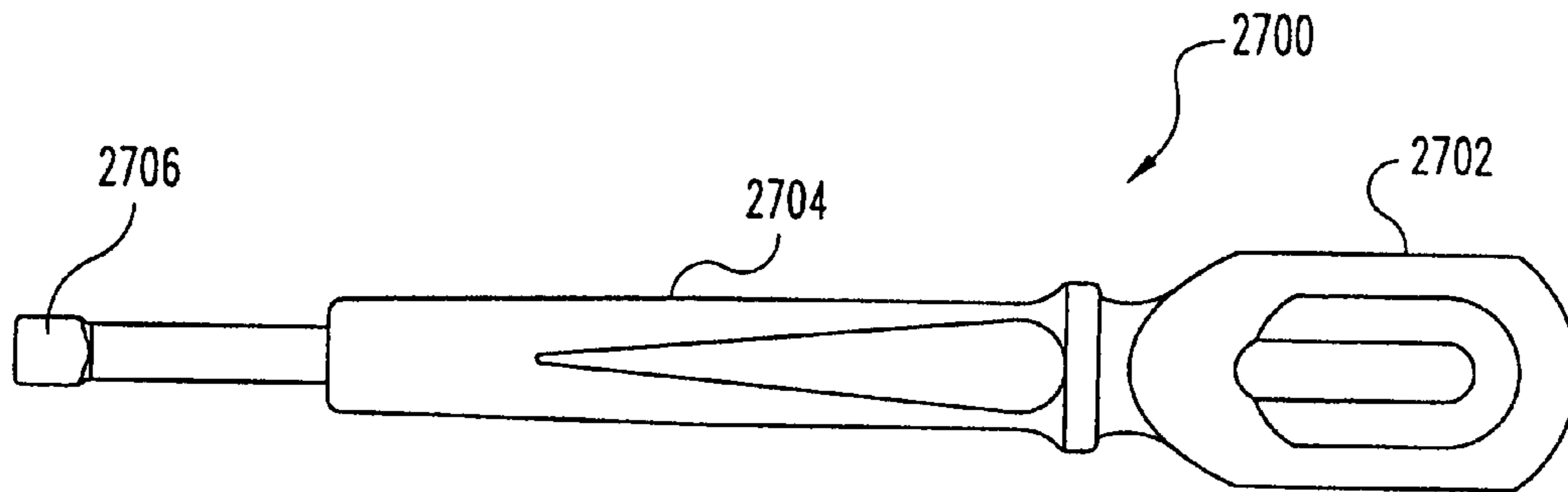

Fig. 28

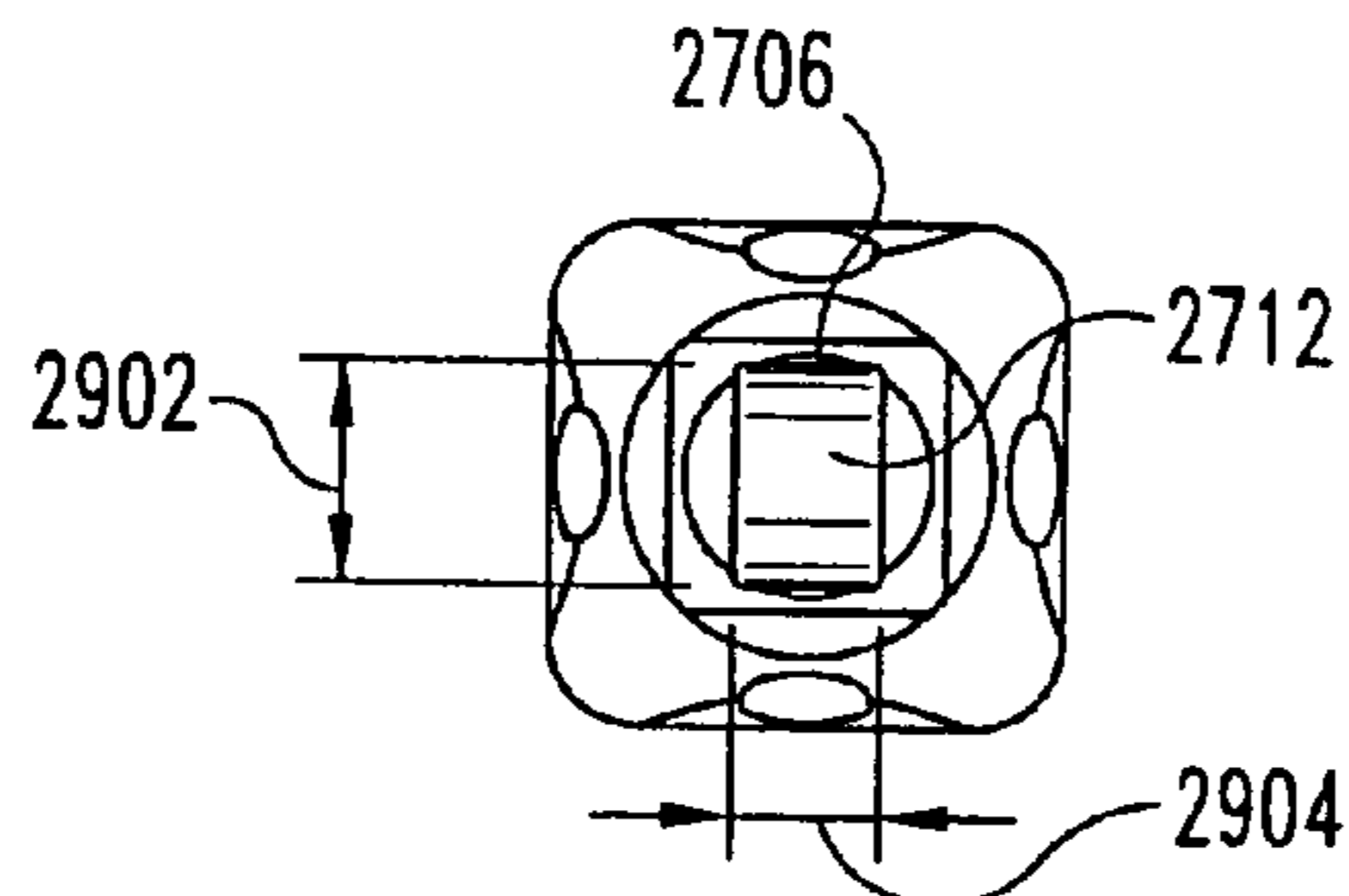

Fig. 29

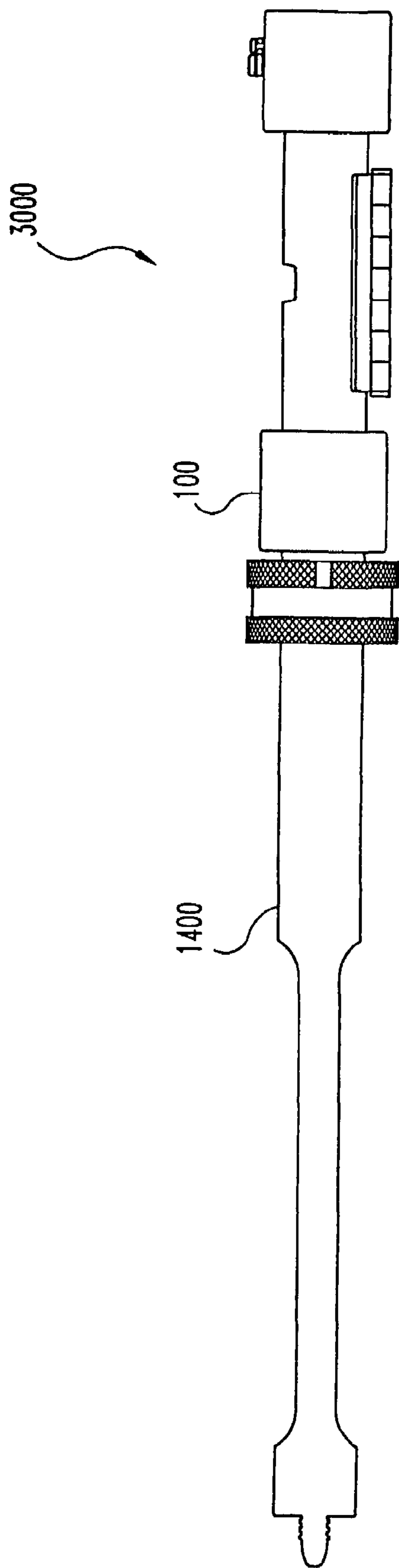

Fig. 30

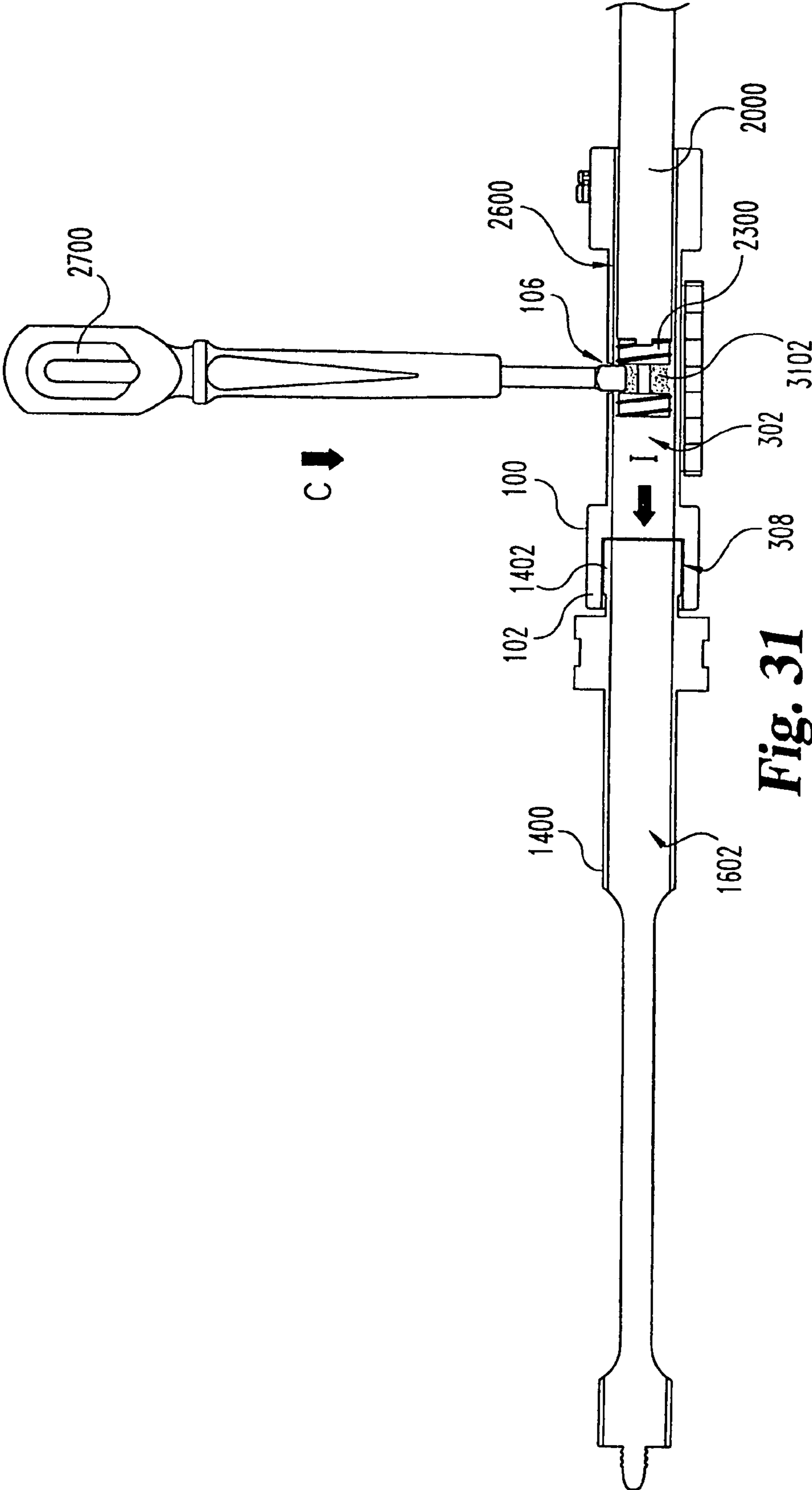

Fig. 31

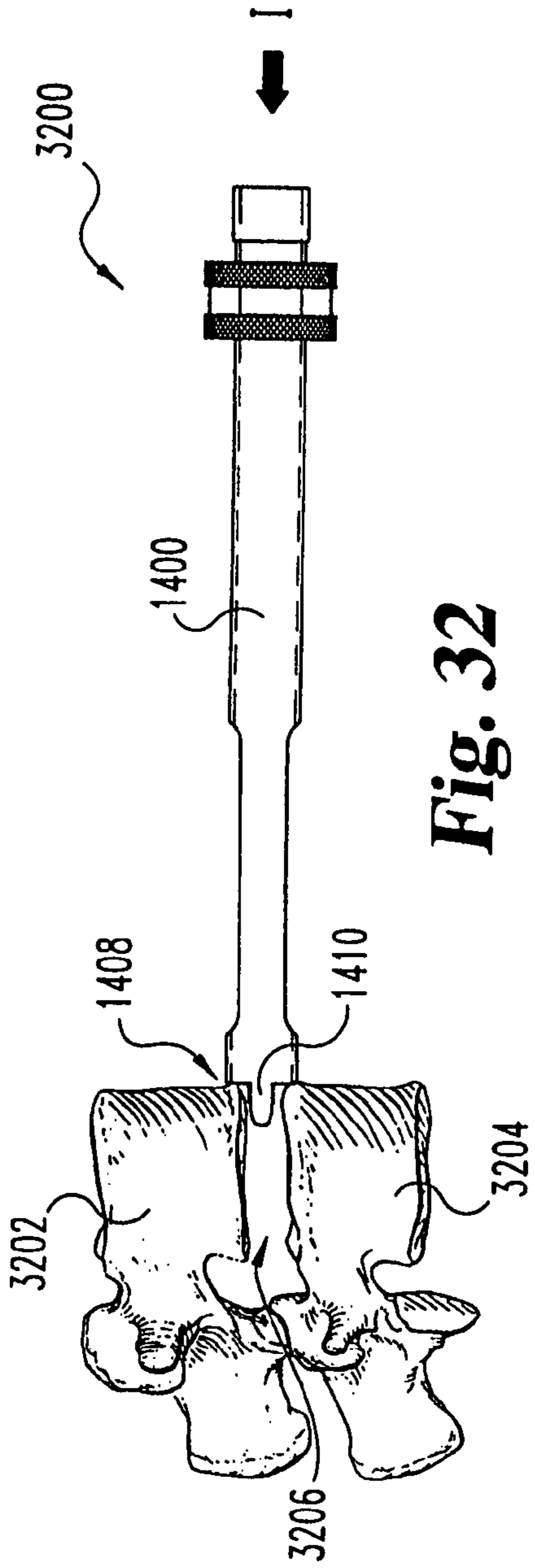

Fig. 32

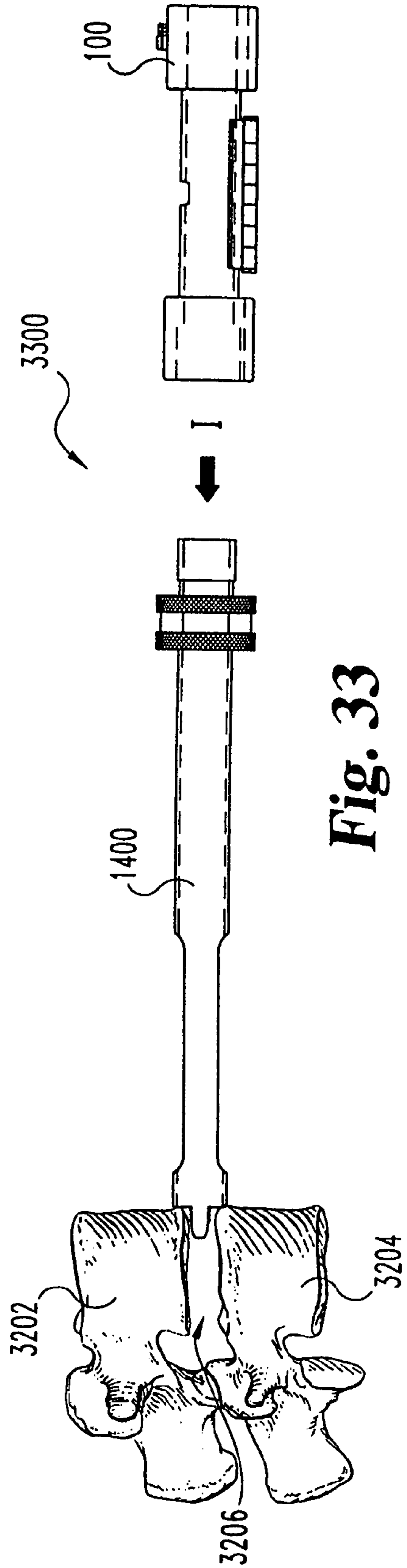

Fig. 33

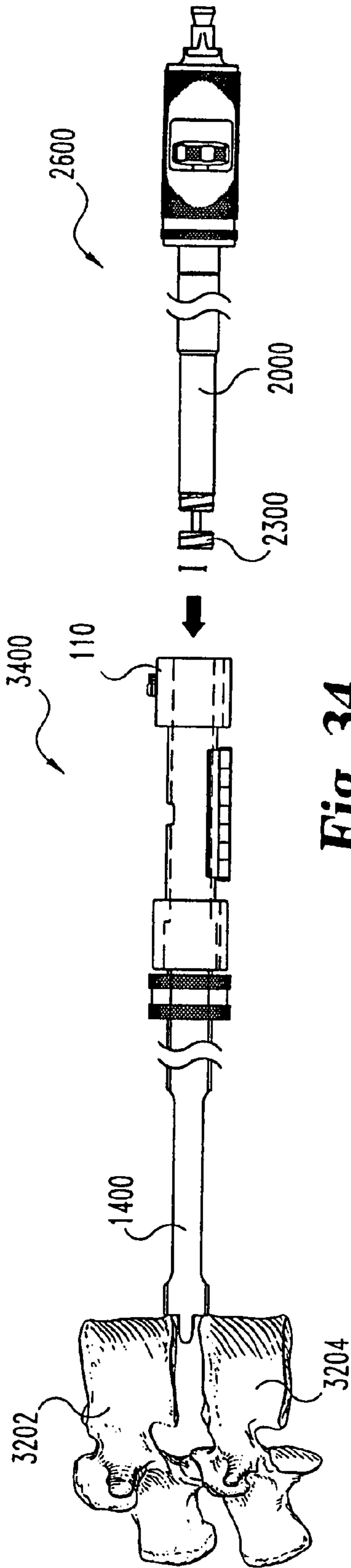

Fig. 34

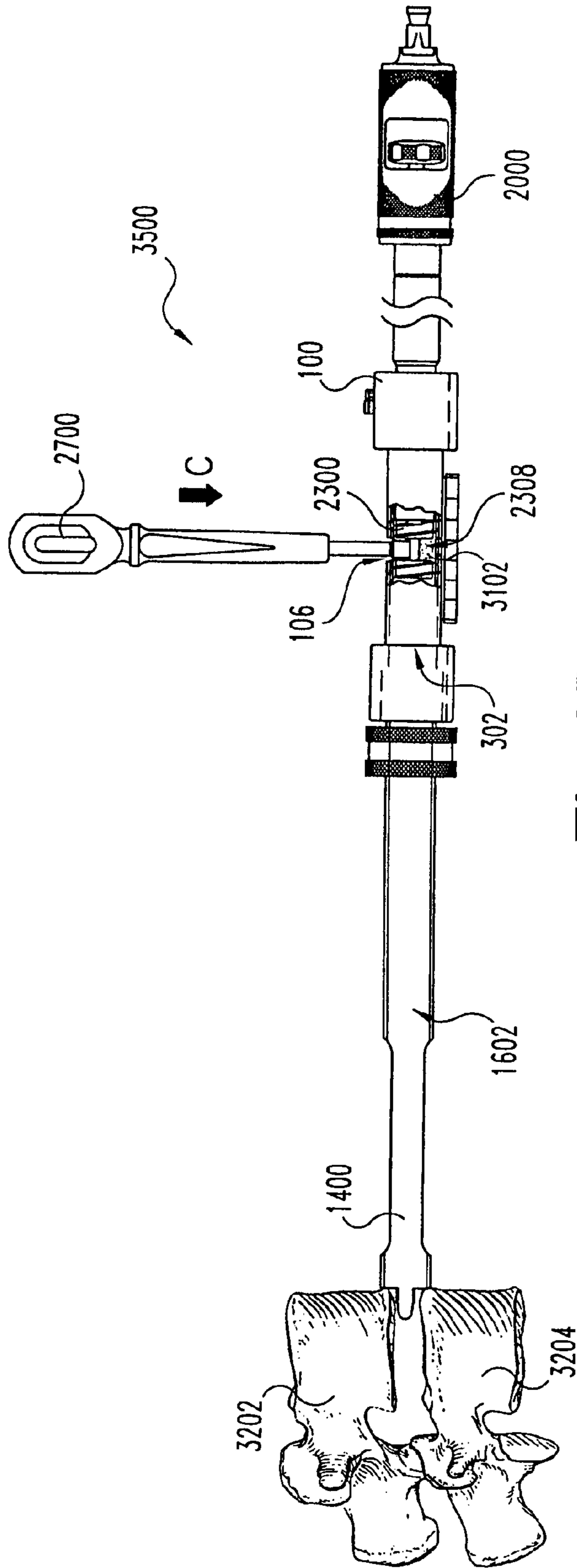

Fig. 35

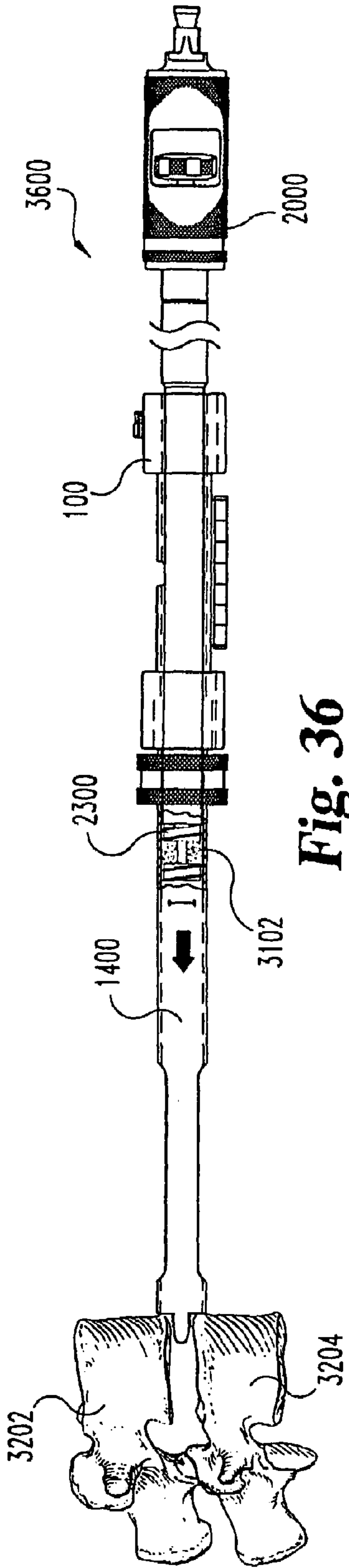

Fig. 36

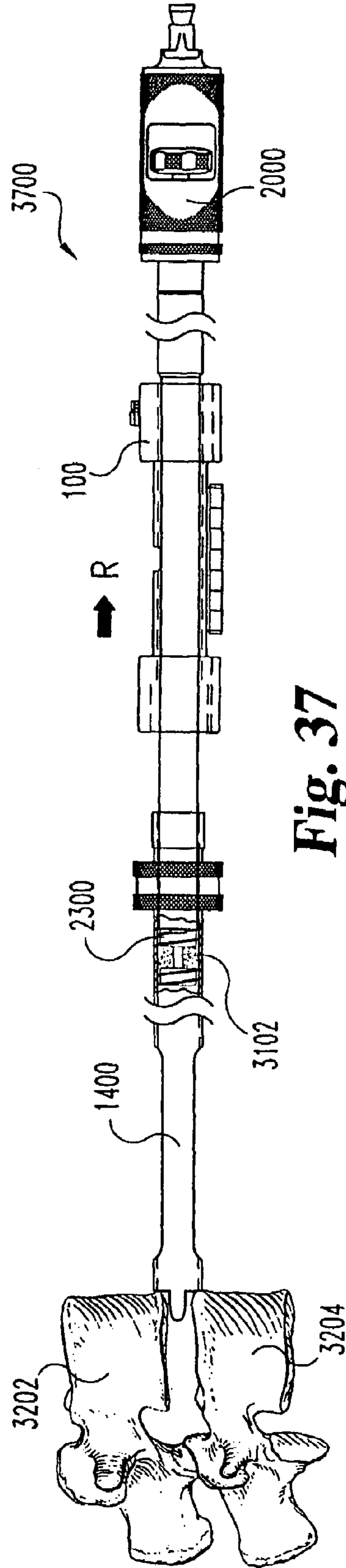

Fig. 37

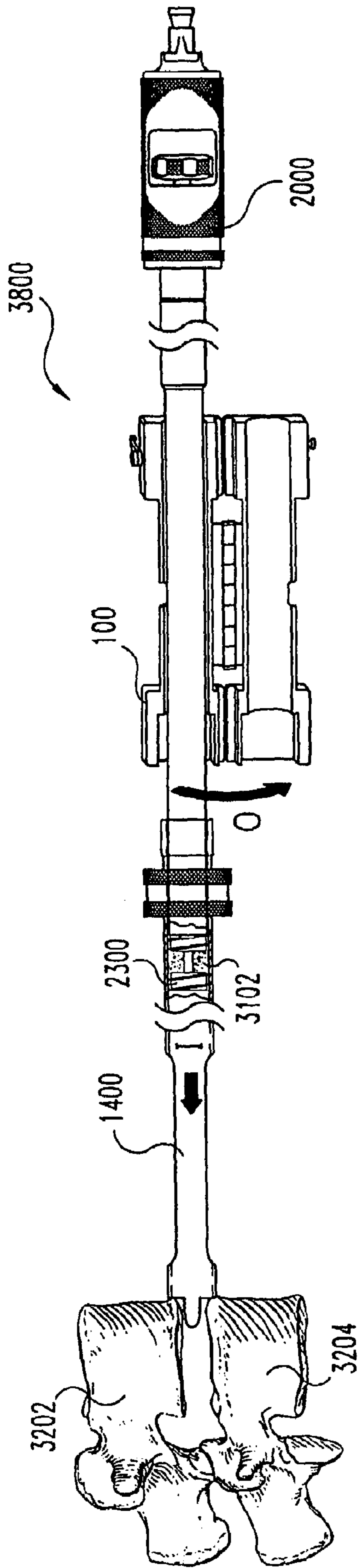

Fig. 38

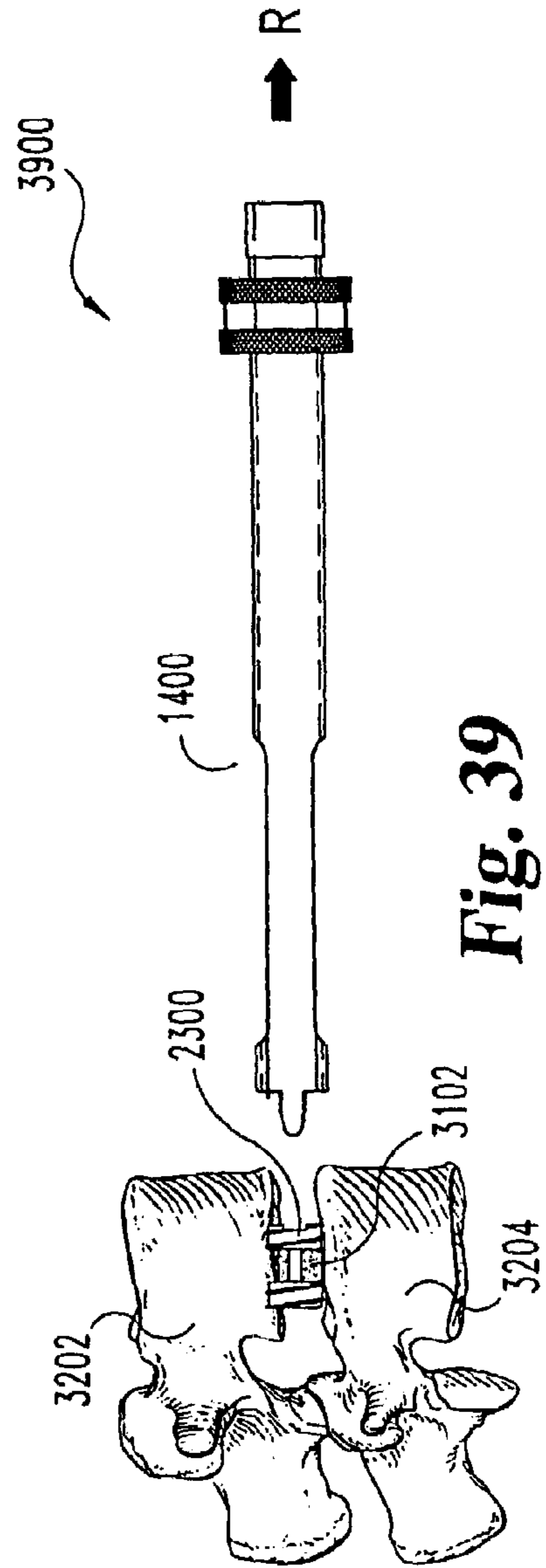

Fig. 39

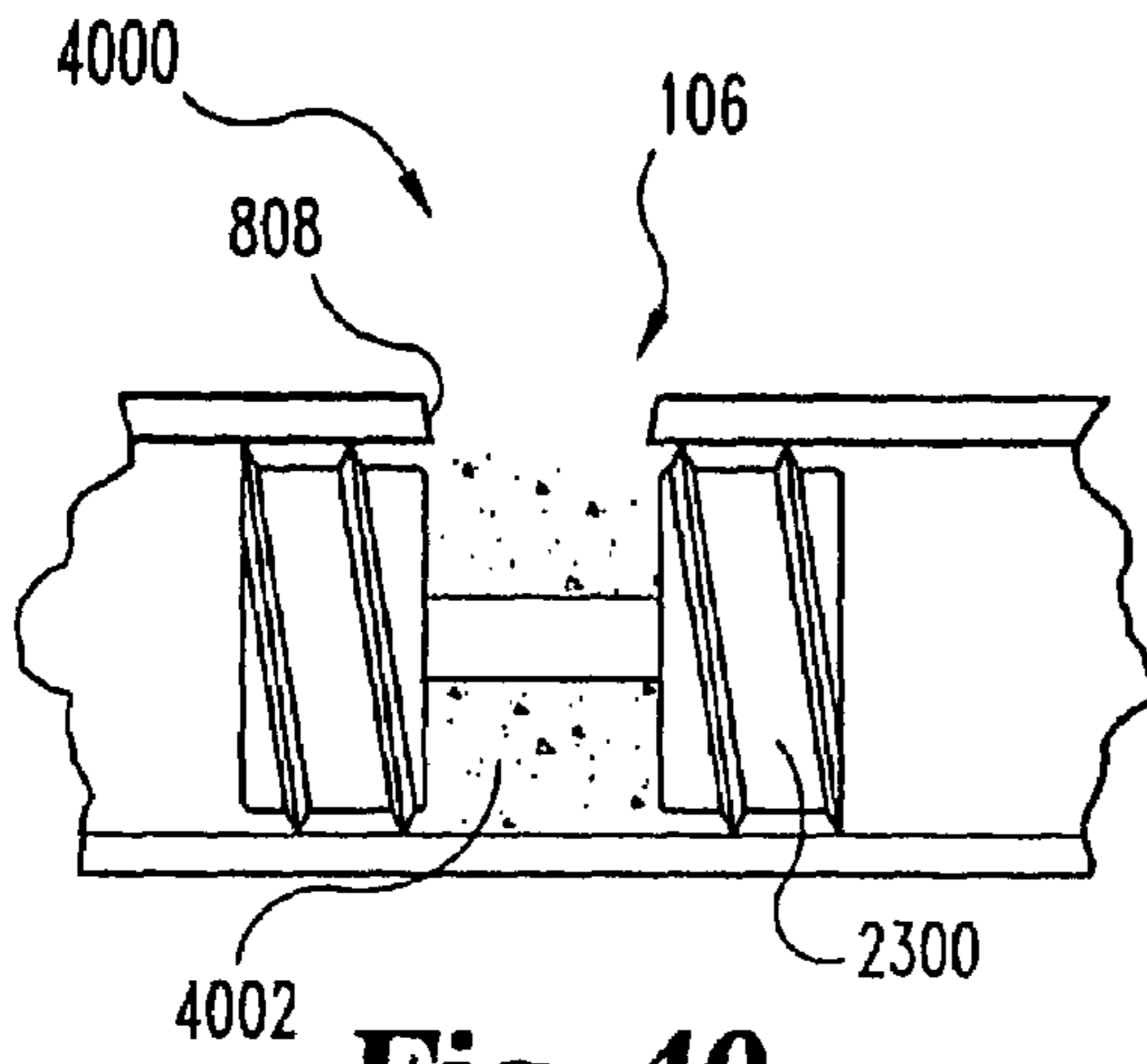

Fig. 40

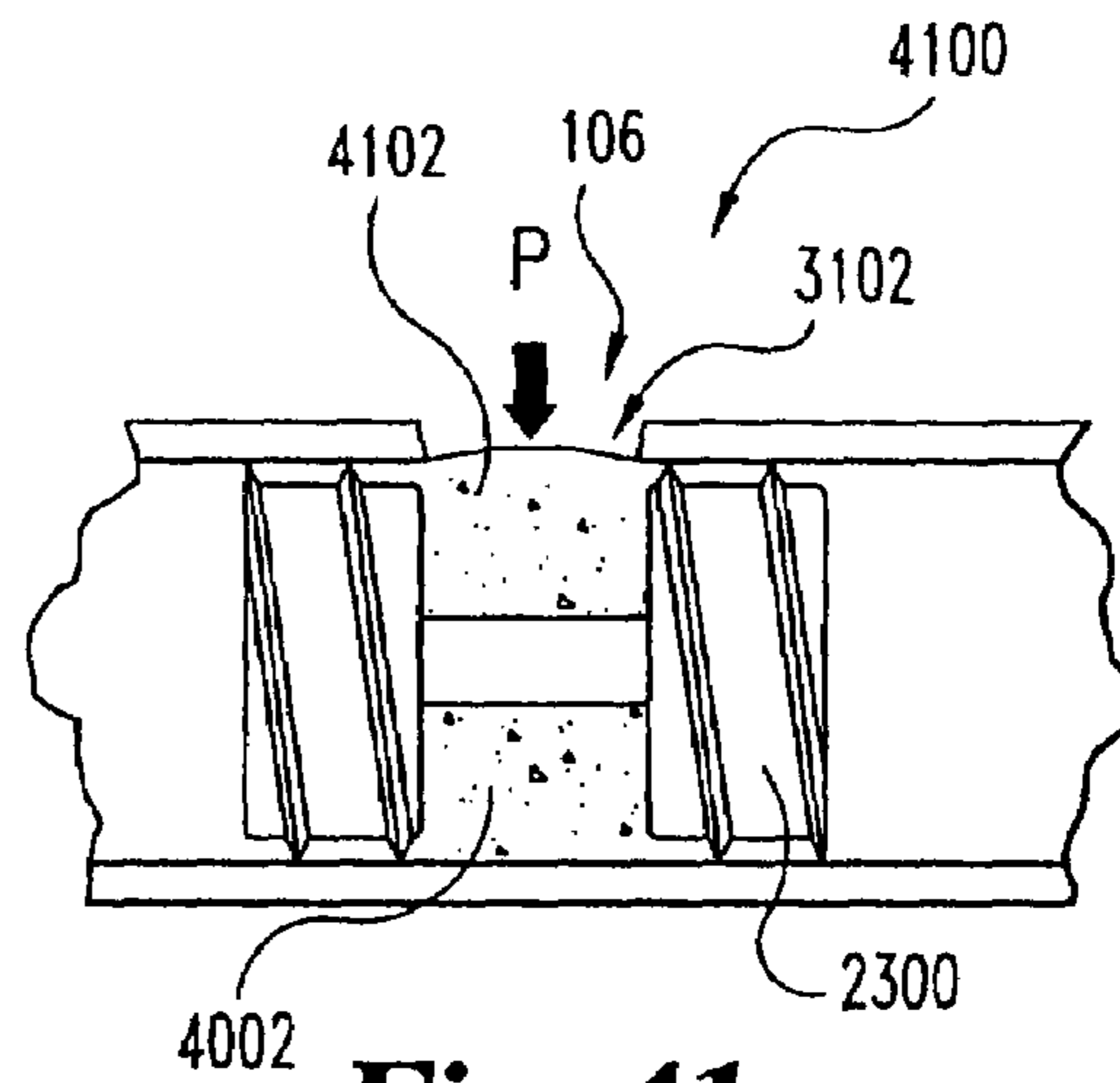

Fig. 41

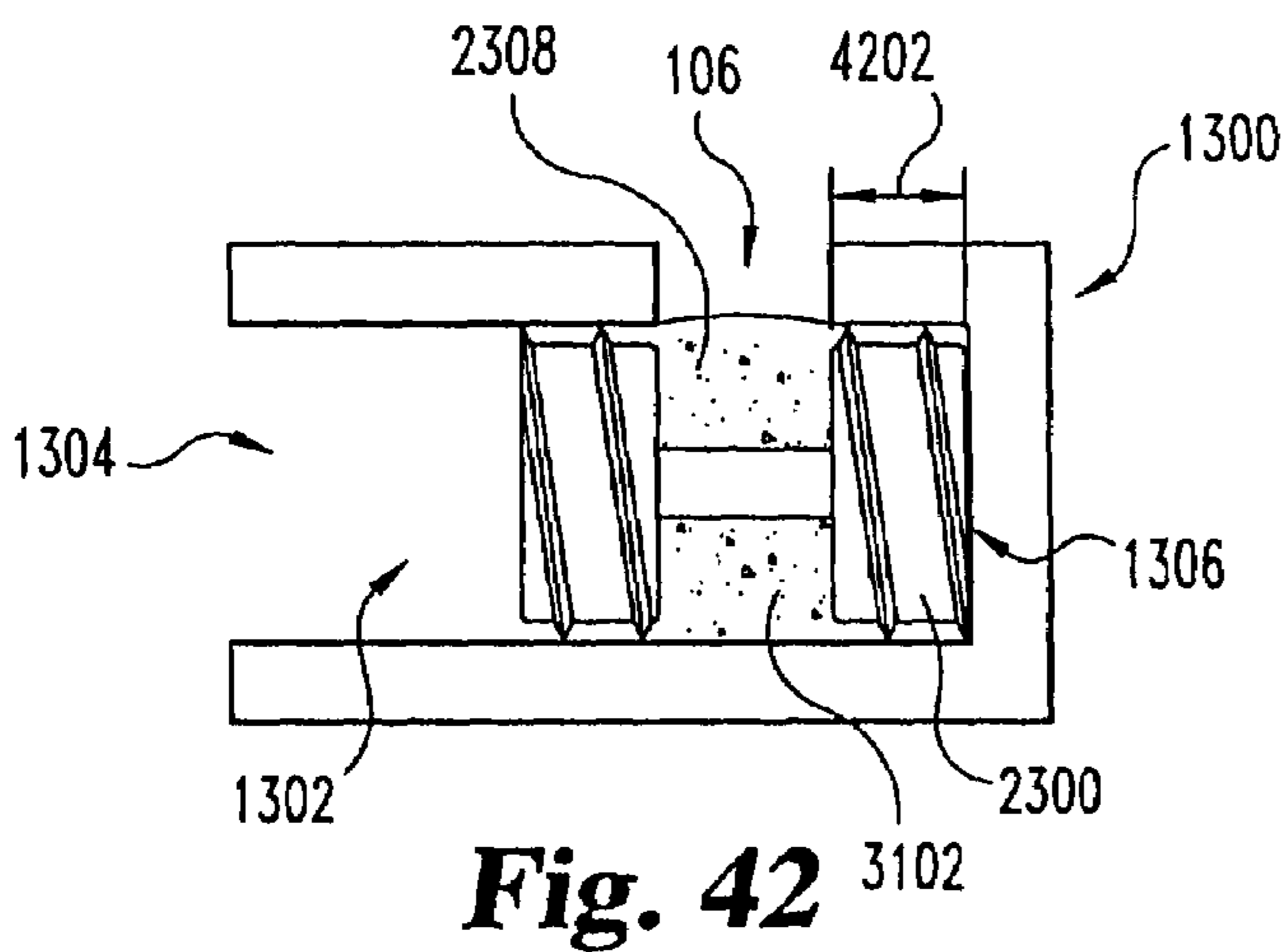

Fig. 42

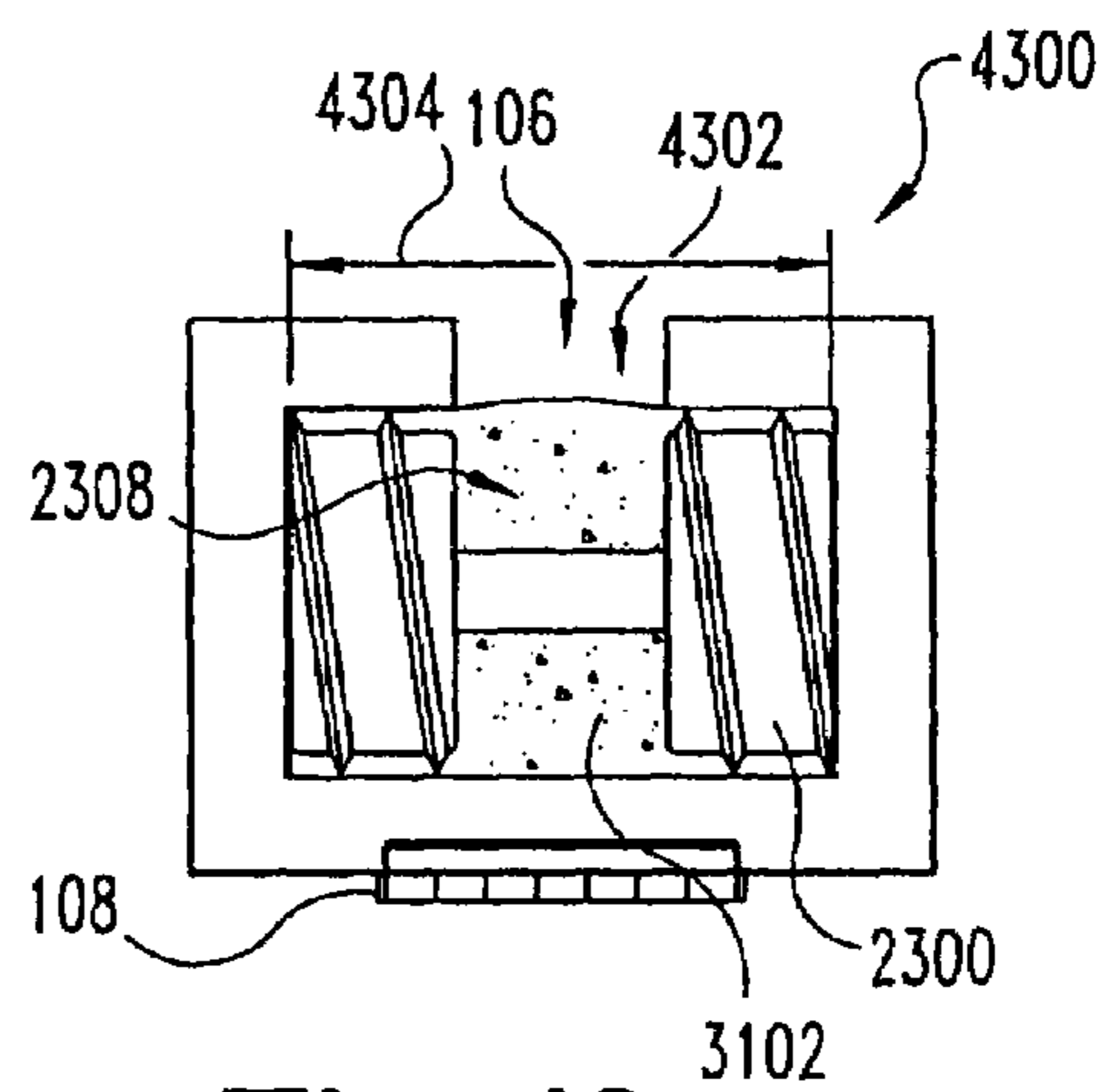

Fig. 43

1

OSTEOGENIC PACKING DEVICE AND METHOD**CROSS-REFERENCE TO RELATED APPLICATIONS**

The present application is a divisional of U.S. patent application Ser. No. 10/040,154, filed Oct. 22, 2001 now U.S. Pat. No. 6,780,192, which claims the benefit of U.S. Provisional Patent Application No. 60/242,934, filed Oct. 24, 2000, which are hereby incorporated by reference in their entirety.

BACKGROUND OF THE INVENTION

The present invention generally relates to a device and method for packing material around an object, and more specifically, but not exclusively, relates to a packing device and a method for packing osteogenic material onto a spinal implant.

In many cases, lower back pain originates from damage or defects in the spinal disc between adjacent vertebrae. The disc can be herniated or can be affected by a variety of degenerative conditions. In many cases, these pathologies affecting the spinal disc can disrupt the normal anatomical function of the disc. In some cases, this disruption is significant enough that surgical intervention is indicated.

In one such surgical treatment, the affected disc is essentially removed and the adjacent vertebrae are fused together. In this treatment, a discectomy procedure is conducted to remove the disc nucleus while retaining the annulus. Since the disc material has been removed, a body must be placed within the intervertebral space to prevent the space from collapsing.

In early spinal fusion techniques, bone material, or bone osteogenic fusion devices, were simply disposed between adjacent vertebrae, typically at the posterior aspect of the vertebrae. With such implants, osteogenic material is packed around the implant after the implant is inserted into the intervertebral space. The osteogenic material helps to promote fusion between the adjacent vertebrae. However, packing the osteogenic material around the implant after the implant is inserted can be problematic. For example, a physician may not be able to adequately view whether an adequate amount of osteogenic material is packed around the implant. Further, the osteogenic material may not be tightly bound together. Portions of the osteogenic material may fall out during packing. This can lead to osteogenic debris floating within the patient, which can lead to complications.

In light of this background, there remain needs for improved devices and methods useful in the conduct of spinal fusions and other similar surgeries. The present invention addresses these needs.

SUMMARY OF THE INVENTION

One form of the invention is a unique osteogenic packing device. Another form of the present invention is directed to a unique method for loading osteogenic material.

In another form, the present invention is directed to a unique osteogenic material packing device for packing osteogenic material onto a spinal fusion device. The packing device has a cavity defined therein and is adapted to receive the spinal fusion device. The packing device further has an access port that intersects the cavity for receiving the osteogenic material.

In another form, the present invention is directed to a unique method of loading osteogenic material onto a spinal

2

fusion device. The fusion device is inserted into a cavity of a packing device that includes an access port. The osteogenic material is provided through the access port and onto the fusion device.

5 In still yet another form, the present invention is directed to unique spinal fusion devices having osteogenic material compacted thereupon, advantageously in a configuration to contact adjacent vertebrae upon implantation of the fusion device.

10 Further objects, features, benefits, aspects, and advantages of the present invention shall become apparent from the detailed drawings and descriptions provided herein.

BRIEF DESCRIPTION OF THE DRAWINGS

15 FIG. 1 shows a side view of an osteogenic material packing device in accordance with one embodiment of the present invention.

FIG. 2 shows a top view of the packing device of FIG. 1.

20 FIG. 3 shows cross sectional view of the packing device of FIG. 1.

FIG. 4 shows an end view of one end of the packing device of FIG. 1.

25 FIG. 5 shows an end view of the other end of the packing device of FIG. 1.

FIG. 6 shows an end view of the packing device of FIG. 1 in an open position.

FIG. 7 shows a side view of a packing device with an access port provided in one section.

30 FIG. 8 shows a cross sectional view of a packing device in accordance with still yet another embodiment of the present invention.

FIG. 9 shows an end view of a packing device with a circular cavity.

35 FIG. 10 shows an end view of a packing device with a square cavity.

FIG. 11 shows a side view of a packing device with two coupling members.

40 FIG. 12 shows an end view of a packing device with three differently sized cavities.

FIG. 13 shows a cross-sectional view of a packing device with one opening.

FIG. 14 shows a side view of a cannula.

FIG. 15 shows a top view of the cannula of FIG. 14.

45 FIG. 16 shows an end view of the cannula of FIG. 14.

FIG. 17 shows a cross-sectional view of a cannula in accordance with another embodiment.

FIG. 18 shows an end view of the cannula of FIG. 17.

50 FIG. 19 shows a top view of a packing device integrated into a cannula.

FIG. 20 shows a side view of an inserter.

FIG. 21 shows a cross-sectional view of the inserter of FIG. 20.

55 FIG. 22 shows an end view of one end of the inserter of FIG. 20.

FIG. 23 shows a side view of a fusion device.

FIG. 24 shows an end view of one end of the fusion device of FIG. 23.

60 FIG. 25 shows an end view of the other end of the fusion device of FIG. 23.

FIG. 26 shows a side view of the fusion device of FIG. 23 coupled to the inserter of FIG. 20.

65 FIG. 27 shows a top view of a compactor in accordance with one embodiment of the present invention.

FIG. 28 shows a side view of the compactor of FIG. 27.

FIG. 29 shows an end view of the compactor of FIG. 27.

FIG. 30 shows a side view of an assembly with the cannula of FIG. 14 coupled to the packing device of FIG. 1.

FIG. 31 shows a cross-sectional view of the assembly of FIG. 30.

FIG. 32 shows a side view of a cannula inserted between adjacent vertebrae.

FIG. 33 shows a side view of the assembly of FIG. 32 along with the packing device of FIG. 1.

FIG. 34 shows a side view of an inserter and the assembly shown in FIG. 33.

FIG. 35 shows a partial cross-sectional view of osteogenic material packed around a fusion device.

FIG. 36 shows a partial cross-sectional view of the fusion device in the cannula.

FIG. 37 shows a partial cross-sectional view of the packing device separated from the cannula.

FIG. 38 shows a partial cross-sectional view of the packing device removed from the inserter.

FIG. 39 shows a side view of the cannula removed from the vertebrae.

FIG. 40 shows a partial cross-sectional view of a fusion device with bone chips provided therein.

FIG. 41 shows a partial cross-sectional view of the fusion device of FIG. 40 with a binder provided therein.

FIG. 42 shows a partial cross-sectional view of a fusion device provided in the packing device of FIG. 13.

FIG. 43 shows a partial cross-sectional view of a packing device with closed ends.

DESCRIPTION OF THE PREFERRED EMBODIMENTS

For the purpose of promoting an understanding of the principles of the invention, reference will now be made to the embodiments illustrated in the drawings and specific language will be used to describe the same. It will nevertheless be understood that no limitation of the scope of the invention is thereby intended, such alterations and further modifications in the illustrated device, and such further applications of the principles of the invention as illustrated therein being contemplated as would normally occur to one skilled in the art to which the invention relates.

An osteogenic material packing device 100 in accordance with one embodiment of the invention is depicted in FIGS. 1-6. As shown in FIG. 1, the packing device 100 includes a cannula coupling portion 102, a body portion 104, an access port 106, a connection member 108, an insert receiving portion 110, and a locking mechanism 112. The body portion 104 connects the coupling portion 102 to the insert-receiving portion 110. The port 106 is defined in the body portion 104. It should be understood that the cannula coupling portion 102, the body portion 104, and the insert-receiving portion 110 can have other shapes. In one form, the body portion 104 has a cylindrical shape, and the receiving and coupling portions 102, 112 have a cubic shape. This cubic shape minimizes the risk that the packing device 100 will be damaged by rolling off a surface. It is contemplated that these portions 102, 104, and 110 could be integrated to have a single shape.

As shown in FIG. 2, the packing device 100 has two separate sections 202 and 204. It should be understood that the packing device 100 could be a single piece or can be sectioned in other manners. The two separate sections 202, 204 are coupled together with a connection member 108 and a locking mechanism 112. The connection member 108 in one embodiment is a hinge. The locking mechanism 112 in one form of the invention is a latching mechanism. The locking mechanism 112 includes a hook 206 that engages a pin 208 to

lock the two sections 202, 204 together. It should be appreciated that other types of locking mechanisms can also be used. As shown, the port 106 is defined by both sections 202 and 204, and the port 106 has a length 210 and a width 212 large enough to allow osteogenic material to be packed around a fusion device.

A cross-sectional view of the packing device 100 is shown in FIG. 3. A cavity 302 is defined in the packing device 100. The access port 106 opens into the cavity 302. It should be appreciated that the cavity 302 can have a single opening, multiple openings, or no openings. The cavity 302 in one embodiment has openings 304, 306 at opposite ends of the device 100. In addition, the cavity 302 has a cylindrical shape to accommodate a fusion device with a cylindrical shape. The cavity 302 has a diameter 310 such that the fusion device can fit inside and slide along the cavity 302. It should be appreciated that the cavity 302 can have other shapes in order to accommodate differently shaped fusion devices.

A cannula coupling chamber 308 is defined within the cannula coupling portion 102. A coupling portion of a cannula is received within coupling chamber 308 to couple the cannula to the packing device 100. The cannula coupling chamber 308, as shown in FIG. 4, has a height 402 and a width 404 that are sized so as to allow a cannula to couple to the packing device 100. In addition, the rectangular shape of the coupling chamber 308 prevents the separate sections 202, 204 from separating when the packing device 100 is coupled to a cannula. Although a rectangular shaped coupling chamber 308 is shown, it should be appreciated that the coupling chamber 308 can have a different shape in order to accommodate a differently shaped cannula. The coupling portion 102 in another embodiment is shaped such that the coupling portion 102 fits inside the cannula. As should be understood, coupling portion 102 of the packing device 100 can be coupled to other types of devices besides cannula.

FIG. 5 shows the receiving portion end 110 of the packing device 100. A fusion device is inserted into the packing device 100 through the receiving portion end 110. The packing device 100 further includes a slot 312 defined in both the cannula coupling portion 102 and the insert receiving portion 110. The legs defined by the slot 312 can provide clearance for the packing device 100.

As shown in FIG. 6, the locking mechanism 112 can be unlocked so that the packing device 100 can be opened. The two separate sections 202, 204 open in an opening direction O by pivoting about the connection member 108. This feature allows the packing device 100 to be easily removed during surgery, and allows for easy cleaning of the cavity 302. It should be understood that the two separate sections 202 and 204 can be coupled together and separated in other manners.

A packing device 700 in accordance with another embodiment of the present invention is shown in FIG. 7. In this embodiment, the access port 106 is defined in only one of two separate sections 702, 704. By having the access port 106 defined in only one of the sections 702, 704, the shape and position of the port 106 can be more accurately defined.

FIG. 8 shows a packing device 800 in accordance with still yet another embodiment. This packing device 800 includes a cannula coupling portion 802, an insert receiving portion 804, access port 106, and cavity 302. The packing device 800 has a uniform maximum outer dimension 806. In addition, the access port 106 has tapered walls 808, which are used to funnel osteogenic material through the port 106. This packing device 800 does not include the cannula coupling chamber 308. Instead, the coupling portion 802 is coupled to a cannula

by inserting the coupling portion **802** into a coupling chamber in the cannula (which will be discussed below with reference to FIG. 17).

An end view of a packing device **900** in accordance with another embodiment is shown. The packing device **900** has a circular cavity **902**, a circular outer shape **904** at coupling portion **906**. The circular cavity **902** coincides with a fusion device that has a circular profile. The circular outer shape **904** at the coupling portion can be coupled to a cannula with a circular coupling member.

A packing device **1000** in accordance with still yet another embodiment is shown in FIG. 10. In this embodiment, the packing device **1000** has a rectangular cavity **1002** to accommodate a fusion device that has a rectangular cross-sectional profile. In particular, the illustrated rectangular cavity **1002** has a square cross-sectional shape. Further, the device **1000** has a rectangular coupling chamber **1006** at coupling portion **1004**. The rectangular coupling chamber **1006** accommodates a cannula with rectangular ends. The packing device **1000** further has a rectangular outer shape **1008**.

Still yet another embodiment of a packing device **1100** according to the present invention is shown in FIG. 11. The packing device **1100** has a connection member **108** which includes two hinges **1102** and **1104**, respectively provided on the cannula coupling portion **102** and the insert receiving portion **110**. By having the hinges **1102**, **1104** on separate ends can improve the stability of the packing device **1100**.

Depending on the physiology of a patient, fusion devices of different sizes may be required. To solve this problem, a packing device **1200** in accordance with the present invention has multiple cavities. As shown in FIG. 12, the packing device **1200** includes a first cylindrical cavity **1202** with a first diameter **1204**, a second cylindrical cavity **1206** with a second diameter **1208**, and a third cylindrical cavity **1210** with a third diameter **1212**. The diameters **1204**, **1208**, **1212** of the cavities **1202**, **1206**, **1210** are different in order to accommodate fusion devices having different outer dimensions. This feature gives a surgeon the flexibility to use differently sized fusion devices depending on the needs of a patient.

FIG. 13 shows a packing device **1300** having a cavity **1302** with a single opening **1304** and a closed end **1306**. A fusion device is inserted and removed through the single opening **1304**. The closed end **1306** acts as a stop for properly positioning the fusion device under access port **106**.

A cannula **1400** in accordance with one embodiment of the present invention is shown in FIG. 14. The cannula **1400** at one end has a packing device coupling member **1402**. The cannula **1400** at the coupling member **1402** is coupled to the cannula coupling portion **102** of the packing device **100**. The cannula **1400** also includes a handle portion **1404**, a pair of view ports **1406**, and a vertebrae engaging portion **1408**. The vertebrae engaging portion **1408** includes a pair of vertebrae engaging members **1410**. The vertebrae engaging members **1410** each have serrations **1412**, and the serrations **1412** are used to secure the cannula to adjacent vertebrae. The vertebrae engaging members **1410** along with serrations **1412** aid in the attachment of the cannula between adjacent vertebrae. A surgeon can grasp the handle portion **1404** in order to position the cannula **1400**. The optional view ports **1406** allow the surgeon to view a fusion device during surgery. It should be appreciated that the cannula **1400** can include a single, multiple, or no view ports **1406**. In one embodiment, the cannula **1400** does not include a view port in order to minimize the risk that osteogenic material falling off the fusion device during insertion.

The coupling member **1402** can have different shapes based on the shape of the fusion device. As shown in FIG. 16,

the coupling member **1402** in one form of the present invention has a rectangular (square) shape with a height **1606** and a width **1608**. The coupling member **1402** is dimensioned such that the coupling member **1402** can fit within the coupling chamber **308** of the packing device **100** and so that the cavity **302** of the packing device **100** aligns with the passage **1602** of the cannula **1400**.

The cannula **1400** includes a cylindrical passage **1602** having a diameter **1604**. The passage **1602** has a diameter sufficiently large such that the fusion device can pass through. The passage **1602** is aligned with the cavity **302** of the packing device **100** to allow for easy sliding of the fusion device therein. It should be appreciated that the passage **1602** can have various shapes and dimensions so as to match the profile of a fusion device. It should be understood that the cannula **1400** can omit features and/or include additional features.

A cannula **1700** in accordance with another embodiment is shown in FIG. 17. The coupling member **1402** includes a coupling chamber **1702** in which the coupling portion **802** of packing device **800** (FIG. 8) is inserted and coupled to the cannula **1700**. Further, the cannula **1700** does not include a view port **1406**. An end view of the coupling portion **1402** is shown in FIG. 18. The coupling chamber **1702** has a square shape with a width **1802** and a length **1804** which can accommodate the outer dimensions of the coupling portion **802** of the packing device **800**. In still yet another embodiment, the packing device **100** and the cannula **1400** are combined into a single simplified device **1900** as shown in FIG. 19. The access port **106** is defined in the cannula **1900**. A fusion device is inserted into device **1900**, and osteogenic material is packed through port **106** onto the fusion device.

An inserter **2000** according to one embodiment of the present invention is shown in FIG. 20. The inserter **2000** includes a shaft **2002**, a coupling end **2004** at one end of the shaft **2002**, and a handle portion **2006** provided at the other end of the shaft **2002**. A coupling mechanism **2008** is provided within the shaft **2002** for coupling fusion a device to the inserter **2000**. The shaft **2002** includes a tapered portion **2010** and depth markings **2012**. The coupling end **2004** has a ridge **2014**, and the handle portion **2006** has an opening **2016** in which a portion of the coupling mechanism **2008** is provided. Further, the handle portion **2006** includes a roughened surface **2018** and a connector **2020**. The depth indicators **2012** are used to indicate the depth of the inserter **2000** during surgery. The roughened surface **2018** on the handle portion **2006** helps to improve grip during surgery.

As shown in FIGS. 21-22, the inserter **2000** includes a passageway **2102** in which the coupling mechanism **2008** passes through. The coupling mechanism **2008** includes a shaft **2104** with a threaded portion **2106** at the coupling end **2004** and a knob **2108**. It should be appreciated that the shaft **2104** can have the threaded portion **2106** extend only over a portion of the shaft **2104** or extend over the entire length of the shaft **2104**. It should be understood that other types of coupling members can be incorporated into the inserter **2000** depending on the type of fusion device used.

Numerous types of fusion devices can be used in accordance with the present invention, including for example those disclosed in WO99/29271 published Jun. 17, 1999, which is hereby incorporated herein by reference in its entirety. FIG. 23 shows one such type of fusion device **2300**. The fusion device **2300** includes a first end piece **2302**, a second end piece **2304**, and a central element **2306** coupling the two end pieces **2302**, **2304** together. A cavity **2308** is formed between the two end pieces **2302**, **2304** in which osteogenic material is packed. The first end piece **2302** has a width **2312**, and the second end piece **2304** has a width **2314**. The cavity **2308**

between the end pieces **2302**, **2304** has a width **2316**, which approximately corresponds to the length **210** of the opening **106** in the packing device, and the fusion device **2300** has an overall length **2318**. This arrangement allows a surgeon to have complete access to fill the cavity **2308** of the fusion device **2300**. It should be understood that fusion devices with configurations different than the one shown can also be used.

As shown in FIG. **24**, one of the end pieces **2302** includes apertures **2402** through which osteogenic material can pass through. The second end **2304** includes a notch **2502** in which the ridges **2014** of the inserter **2000** are coupled. In addition, the fusion device **2300** includes a threaded hole **2504**, which engages the threaded portion **2106** of the coupling mechanism **2008**. It should be understood that the fusion device **2300** can be coupled to the inserter **200** in other generally known manners.

FIG. **26** shows the inserter **2000** coupled to the fusion device **2300** to form an inserter-fusion device assembly **2600**. The ridge **2014** of the inserter **2000** engages the groove **2502** in the fusion device **2300**. This engagement allows the fusion device **2300** to be screwed between adjacent vertebrae.

A compactor **2700** in accordance with one embodiment of the present invention is shown in FIGS. **27-29**. The compactor **2700** includes a handle portion **2702**, a shaft **2704** coupled to the handle portion **2702**, and a plunger **2706** coupled to the shaft **2704**. The shaft **2704** includes a tapered portion **2708** coupled to the handle portion **2702** and a non-tapered portion **2710** coupled to the plunger **2706**. The plunger **2706** includes a contacting surface **2712**. In one embodiment, the contacting surface is curved in order to improve packing of material around the fusion device **2300**. The curvature of the contacting surface **2712** matches the curvature of the cavity **302** of the packing device **100** so that the osteogenic material can be uniformly provided around the fusion device **2300**. As shown in FIG. **29**, the contacting surface **2712** of the plunger **2706** has a length **2902** and a width **2904**. In one form, this length **2902** is slightly smaller than the width **212** of the port **106** so that the plunger **2706** can fit through the port **106**. This profile of the plunger **2706** roughly corresponds to the size of the port **106** in the packing device **100**. This profile ensures that the fusion device **2300** is adequately packed with osteogenic material.

A cannula-packing device assembly **3000** is shown in FIG. **30**. The assembly **3000** includes the packing device **100** and the cannula **1400** coupled to the packing device **100**. A cross-sectional view of the coupled packing device **100** and cannula **1400** is shown in FIG. **31**. The cannula coupling portion **102** with coupling chamber **308** is coupled to packing device coupling member **1402**. The inserter **2000** is coupled to the fusion device **2300**, and the fusion device **2300** along with the inserter **2000** are inserted into the packing device in direction I. The compactor **2700** is moved in direction C through port **106** in order to compact osteogenic material **3102** around the fusion device **2300**. As shown, the cavity **302** of the packing device **100** is aligned with the passage **1602** of the cannula **1400** so that the fusion device **2300** can be easily slid from the packing device **100** into the cannula **1400**.

A method for packing osteogenic material in accordance with one embodiment of the present invention will now be described in reference to FIGS. **32-39**. In stage **3200**, as shown in FIG. **32**, the cannula **1400** is inserted in direction I into an intervertebral space **3206** between adjacent vertebrae **3202**, **3204**. The vertebrae engaging members **1410** engage the adjacent vertebrae **3202**, **3204**. The serrations **1412** reduce slippage of the cannula **1400** from the vertebrae **3202**, **3204**. In stage **3300**, the packing device **100** is moved in direction I and coupled to the cannula **1400**. The inserter-

fusion device assembly **2600** is inserted in direction I into the insert receiving portion **100** of the fusion device **100** in stage **3400**. The cavity **2308** of the fusion device **2300** is aligned with the access port **106** of the packing device **100** as shown in FIG. **35**. In stage **3500**, osteogenic material **3102** is packed into the cavity **2308** of the fusion device **2300**. The compactor **2700** is moved in direction C to press the osteogenic material **3102** into the cavity **2308**. The osteogenic material may be selected from among many known to those skilled in the art. For example, the osteogenic material may comprise minerals such as calcium phosphate or calcium sulfate minerals, bone, including xenograft, allograft or autograft bone, or the like. The osteogenic material may also comprise demineralized bone matrix (DBM), osteoinductive factors such as bone morphogenetic proteins (e.g. human BMP-2 or human BMP-7 or heterodimers thereof) whether recombinantly produced or purified from tissues, LIM mineralization proteins (LMPs), or the like. The osteogenic material may also comprise a binder material such as blood, clottable blood fractions, platelet gel, collagen, gelatin, carboxymethyl cellulose, or other similar materials that will serve to bind together harder particles or materials such as mineral particles (e.g. bone or synthetic mineral particles) so as to create a three-dimensionally stable mass when compacted on the spinal fusion implant. Such binder can be admixed with other materials in the osteogenic composition prior to or after loading the other materials into the cavity **2308**. As will be appreciated, the binder may be a hardenable material such as a gel-forming, clottable, or cross-linkable material, or can be a material which is not hardenable but nonetheless serves to bind particles together to provide integrity to the compacted osteogenic mass.

After the osteogenic material **3102** is compacted around the fusion device **2300**, the inserter **2000** is moved in direction I in stage **3600** so that the fusion device **2300** is moved into the cannula **1400** (FIG. **36**). After the fusion device **2300** is within the cannula **1400**, the packing device **100** is moved in direction R, as shown in FIG. **37**, along the inserter **2000** to decouple the packing device **100** from the cannula **1400** in stage **3700**. The locking mechanism **112** is unlocked. Then, the packing device **100** is opened in direction O and removed from the inserter **2000** in stage **3800**. As shown in FIG. **38**, the inserter **2000** then moves the fusion device **2300** in direction I so that the fusion device **2300** along with the osteogenic material **3102** can be inserted into the intervertebral space **3206**. As shown in FIG. **39**, after the fusion device **2300** is inserted between the vertebrae **3202**, **3204**, the cannula **1400** is removed by moving the cannula **1400** in direction R in stage **3900**.

One method for providing osteogenic material **3102** around the fusion device **2300** in accordance with another embodiment of the present invention is shown in FIGS. **40-41**. In stage **4000**, osteogenic material chips **4002** such as bone chips or mineral particles are packed through port **106** around the fusion device **2300**. In stage **4100**, a binder **4102** is poured in direction P through port **106** to form osteogenic material **3102**. The access portion **106** has tapered walls **808**, which funnels the binder **4102** through the port **106**. The binder and chips or particles are then admixed and compacted together around the fusion device **2300**.

In another specific form of the invention, autograft chips are loaded through port **106**. Blood residual on the bone chips and/or blood from the patient or a donor may serve as a binder in this method. After a short time, the blood clots and the fusion device **2300** with the osteogenic material **3102** is removed. The clotted blood acts as a binder and retains the bone chips during implantation. As will be understood, clot-

ting of the blood may be facilitated by the addition of appropriate factors such as thrombin, etc. In another form, platelet gel is used as a binder to provide an even stronger cohesiveness. Calcium phosphate cements with or without osteogenic growth factors such as BMP are used in still yet another form. 5

As noted above, the osteogenic material **3102** can include autograft bone, allograft bone and/or demineralized bone. Likewise, the chips **4002** can include allograft, autograft, and/or demineralized bone chips. The osteogenic material **3102** such as bone chips, once inserted can optionally be of sufficient strength provide some additional compressive properties to maintain the intervertebral disc space **3206** after distraction. In another embodiment, a self setting cement is used alone or in combination with bone chips. The self setting cement offers superior compressive properties. 10

Another embodiment for a method of providing osteogenic material around a fusion device will now be described with reference to FIG. **42**. The packing device **1300** (FIG. **13**) is shown in FIG. **42**. The fusion device **2300** is inserted into the cavity **1302** of the packing device **1300**. The depth **4202** of the cavity **1302** between the closed end **1306** and the access port **106** is substantially equal to the width **2312**, **2314** of one of the end pieces **2302**, **2304** of the fusion device **2300**. This distance **4202** allows the cavity **2308** of the fusion device **2300** to be properly aligned under the access port **106**. Once inserted, osteogenic material **3102** is poured and/or packed into the cavity **2308** of the fusion device **2300**. After the osteogenic material **3102** is provided around the fusion device **2300**, the fusion device **2300** is then removed out of the opening **1304**. The fusion device **2300** in one form is inserted and removed using the inserter **2000**. It should be understood that the fusion device **2300** can be inserted and removed from the packing device **1300** in other manners such as by hand. Once removed, the fusion device **2300** can then be directly inserted into the intervertebral space **3206** or can be indirectly inserted by using the cannula **1400**. 15

A method according to still yet another embodiment of the present invention will now be described with reference to FIG. **43**. A packing device having a closed cavity **4302** is used. The packing device **4300** is opened along coupling mechanism **108** in a manner similar to the one shown in FIG. **6**. The fusion device **2300** is then inserted into the cavity **4302**, and the fusion device **4300** is then closed. As shown in FIG. **43**, the length **4304** of the cavity **4302** is slightly larger than the length of the fusion device **2300** such that the cavity **2308** of the fusion device **2300** is aligned with the access port **106** of the packing device **4300**. Osteogenic material **3102** is then packed and/or poured around the fusion device **2300**. Then, the packing device **4300** is opened to remove the fusion device **2300**. 20

While specific embodiments of the present invention have now been shown and described in detail, the breadth and scope of the present invention should not be limited by the above described exemplary embodiments, but should be defined only in accordance with the following claims and their equivalents. All changes and modifications that come within the spirit of the invention are desired to be protected. 25

What is claimed is:

1. A method of loading osteogenic material onto a fusion device, comprising:

providing a fusion device having a predetermined size and shape including a length and a width, the fusion device having a central portion extending between opposite end portions, the central portion extending along the length of the fusion device and defining a cavity; 30

inserting the fusion device having the predetermined size and shape into a cavity of a packing device that includes an access port, in which the fusion device has an outside; providing the osteogenic material through the access port and onto the fusion device, said providing including packing the osteogenic material around the outside of the fusion device and into the cavity defined by the central portion of the fusion device; 35

coupling the packing device to a cannula in which a passage of the cannula is aligned with the cavity of the packing device;

sliding the fusion device into the passage of the cannula after said providing; and

removing the packing device from the cannula after said sliding. 40

2. The method of claim **1**, wherein said providing includes packing the osteogenic material onto the fusion device with a compactor.

3. The method of claim **1**, wherein said providing includes pouring the osteogenic material through the access port. 45

4. The method of claim **1**, wherein said providing includes packing osteogenic material chips through the access port and pouring a binder through the access port.

5. The method of claim **4**, wherein the chips include autograft bone.

6. The method of claim **4**, wherein the chips include allograft bone.

7. The method of claim **4**, wherein the chips include demineralized bone. 50

8. The method of claim **4**, wherein the binder includes blood.

9. The method of claim **4**, wherein the binder is selected from a group consisting of platelet gel, collagen, gelatin, hyaluronic acid, calcium sulfate, carboxymethyl cellulose, calcium phosphate, peptides, and polymers. 55

10. The method of claim **1**, wherein said providing includes pouring a self-setting cement through the access port.

11. The method of claim **1**, further comprising coupling the fusion device to an inserter. 60

12. The method of claim **1**, further comprising inserting the fusion device between adjacent vertebrae after said providing the osteogenic material through the access port and onto the fusion device. 65

13. The method of claim **1**, further comprising inserting the cannula at an intervertebral space between adjacent vertebrae.

14. The method of claim **13**, wherein said inserting the cannula precedes said providing the osteogenic material.

15. The method of claim **1**, wherein the packing device is integrated in the cannula.

16. The method of claim **1**, further comprising: the packing device including at least two sections locked together with a locking mechanism; and opening the packing device after said providing by unlocking the locking mechanism to separate apart the at least two sections of the packing device. 70

17. The method of claim **1**, further comprising: inserting the fusion device between the adjacent vertebrae by sliding the fusion device from the cannula.

18. A method of loading osteogenic material onto a fusion device, comprising:

inserting the fusion device into a cavity of a packing device that includes an access port, in which the fusion device has an outside; 75

11

providing the osteogenic material through the access port and onto the fusion device, said providing including packing the osteogenic material around the outside of the fusion device;
 closing the packing device around the fusion device before 5
 said providing;
 coupling the packing device to a cannula in which a passage of the cannula is aligned with the cavity of the packing device;
 sliding the fusion device into the passage of the cannula 10
 after said providing; and
 removing the packing device from the cannula after said sliding.

19. A method of loading osteogenic material onto a fusion device, comprising: 15

inserting the fusion device into a cavity of a packing device that includes an access port;
 coupling the fusion device to an inserter before said inserting, and wherein said inserting includes sliding the fusion device into the packing device with the inserter; 20
 providing the osteogenic material through the access port and onto the fusion device;
 coupling the packing device to a cannula in which a passage of the cannula is aligned with the cavity of the packing device; 25
 sliding the fusion device into the passage of the cannula after said providing; and
 removing the packing device from the cannula after said sliding.

20. The method of claim **19**, wherein said removing 30
 includes sliding the fusion device along the inserter and opening the packing device by hingedly separating two portions of the packing device.

21. A method of loading osteogenic material onto a fusion device, comprising: 35

inserting the fusion device into a cavity of a packing device that includes an access port, in which the fusion device has an outside;
 providing the osteogenic material through the access port and onto the fusion device, said providing including 40
 packing the osteogenic material around the outside of the fusion device;
 coupling the packing device to a cannula in which a passage of the cannula is aligned with the cavity of the packing device; 45
 sliding the fusion device into the passage of the cannula after said providing; and
 removing the packing device from the cannula after said sliding; and
 the fusion device including two end pieces, a central element joining the two end pieces together, and a cavity defined between the two end pieces along the central element; and
 said providing the osteogenic material includes packing 50
 the osteogenic material in the cavity around the central element with a compactor. 55

22. A method of loading osteogenic material onto a fusion device, comprising:

providing a fusion device having a predetermined size and shape including a length and a width, and wherein the 60
 fusion device has a central portion extending between

12

opposite end portions, the central portion extending along the length of the fusion device and defining a cavity;

inserting the fusion device having the predetermined size and shape into a cavity of a packing device that includes an access port;

providing the osteogenic material through the access port and onto the fusion device, and wherein the providing the osteogenic material through the access port and onto the fusion device comprises packing the osteogenic material into the cavity defined by the central portion of the fusion device;

coupling the packing device to a cannula in which a passage of the cannula is aligned with the cavity of the packing device;

sliding the fusion device into the passage of the cannula after said providing; and

removing the packing device from the cannula after said sliding.

23. A method of loading osteogenic material onto a fusion device, comprising:

providing a fusion device having a predetermined size and shape including a length and a width;

inserting the fusion device having the predetermined size and shape into a cavity of a packing device that includes an access port;

providing the osteogenic material through the access port and onto the fusion device;

coupling the packing device to a cannula in which a passage of the cannula is aligned with the cavity of the packing device;

sliding the fusion device into the passage of the cannula after said providing; and

removing the packing device from the cannula after said sliding; and

coupling the fusion device to an inserter instrument before the inserting, and wherein the inserting includes positioning the fusion device in the packing device using the inserter instrument.

24. A method, comprising:

providing a fusion device having a predetermined size and shape including a length and a width, and wherein the fusion device has a central portion extending between opposite end portions, the central portion extending along the length of the fusion device and defining a cavity;

inserting the fusion device having the predetermined size and shape inside of a packing device;

packing osteogenic material onto the fusion device located inside of the packing device, and wherein the packing comprises loading the osteogenic material into the cavity defined by the central portion of the fusion device;

sliding the fusion device into the passage of a cannula after said packing;

coupling the packing device to the cannula in which the passage of the cannula is aligned with the packing device before said sliding; and

decoupling the packing device from the cannula after said sliding.