

US007549194B2

(12) **United States Patent**
Vosbikian et al.

(10) **Patent No.:** **US 7,549,194 B2**
(45) **Date of Patent:** **Jun. 23, 2009**

(54) **IMPLEMENTS WITH HANDLES AND WORKING ENDS AND METHODS OF USE THEREOF**

(75) Inventors: **Peter S. Vosbikian**, Moorestown, NJ (US); **Robert E. Petner**, Burlington, NJ (US)

(73) Assignee: **Quickie Manufacturing Corporation**, Cinnaminson, NJ (US)

(*) Notice: Subject to any disclaimer, the term of this patent is extended or adjusted under 35 U.S.C. 154(b) by 0 days.

(21) Appl. No.: **10/804,541**

(22) Filed: **Mar. 19, 2004**

(65) **Prior Publication Data**

US 2005/0204512 A1 Sep. 22, 2005

(51) **Int. Cl.**

B65D 69/00 (2006.01)
A47F 7/00 (2006.01)
B25G 3/32 (2006.01)

(52) **U.S. Cl.** **16/422**; 16/427; 206/576; 206/362

(58) **Field of Classification Search** 16/422, 16/425, 430, 110.5, DIG. 42, 427; 206/576, 206/223, 362

See application file for complete search history.

(56) **References Cited**

U.S. PATENT DOCUMENTS

0,226,891 A	4/1880	Tym	
378,540 A	2/1888	Brough	
577,220 A	2/1897	Whitehead	
1,027,209 A	5/1912	Margolius	
1,750,845 A	3/1930	Lach	
1,913,105 A *	6/1933	Baland et al.	206/362
2,423,292 A	7/1947	Brown	
2,639,454 A *	5/1953	Dory	15/245
3,153,252 A	10/1964	Ricciardi	

3,226,149 A *	12/1965	McJohnson	294/50
3,359,929 A *	12/1967	Carlson	108/53.3
3,380,097 A	4/1968	Pharris	
3,398,825 A *	8/1968	Flook, Jr. et al.	206/209
3,407,424 A	10/1968	Lanzarone et al.	
3,494,201 A *	2/1970	Roach	73/864.14
3,600,740 A *	8/1971	Ogier	15/257.01
3,819,034 A *	6/1974	Clark	206/763
4,070,128 A	1/1978	Garrison	
4,082,186 A *	4/1978	Chirumbolo	206/577
4,132,489 A	1/1979	Berg, Jr. et al.	
4,329,755 A	5/1982	Alissandratos	
4,524,484 A	6/1985	Graham	
4,576,291 A *	3/1986	Stein	211/49.1
4,638,522 A	1/1987	Robertson	
4,667,829 A *	5/1987	Edmund-White	206/575

(Continued)

OTHER PUBLICATIONS

Quickie Prod. No. 064 & 067—See attachment.

(Continued)

Primary Examiner—Robert J Sandy

(74) *Attorney, Agent, or Firm*—Wildman, Harrold, Allen & Dixon LLP

(57) **ABSTRACT**

Implements including handles and working ends and product lines thereof are described. The implements are typically cleaning implements, such as mops and brooms, but may be garden implements such as hoes and rakes. Various methods for using such implements are described. In one aspect, the methods relate to shipping the implements, each of which includes the same overall length. In another aspect, the methods relate to displaying the implements, most often in a retail environment for presentation to consumers.

28 Claims, 7 Drawing Sheets

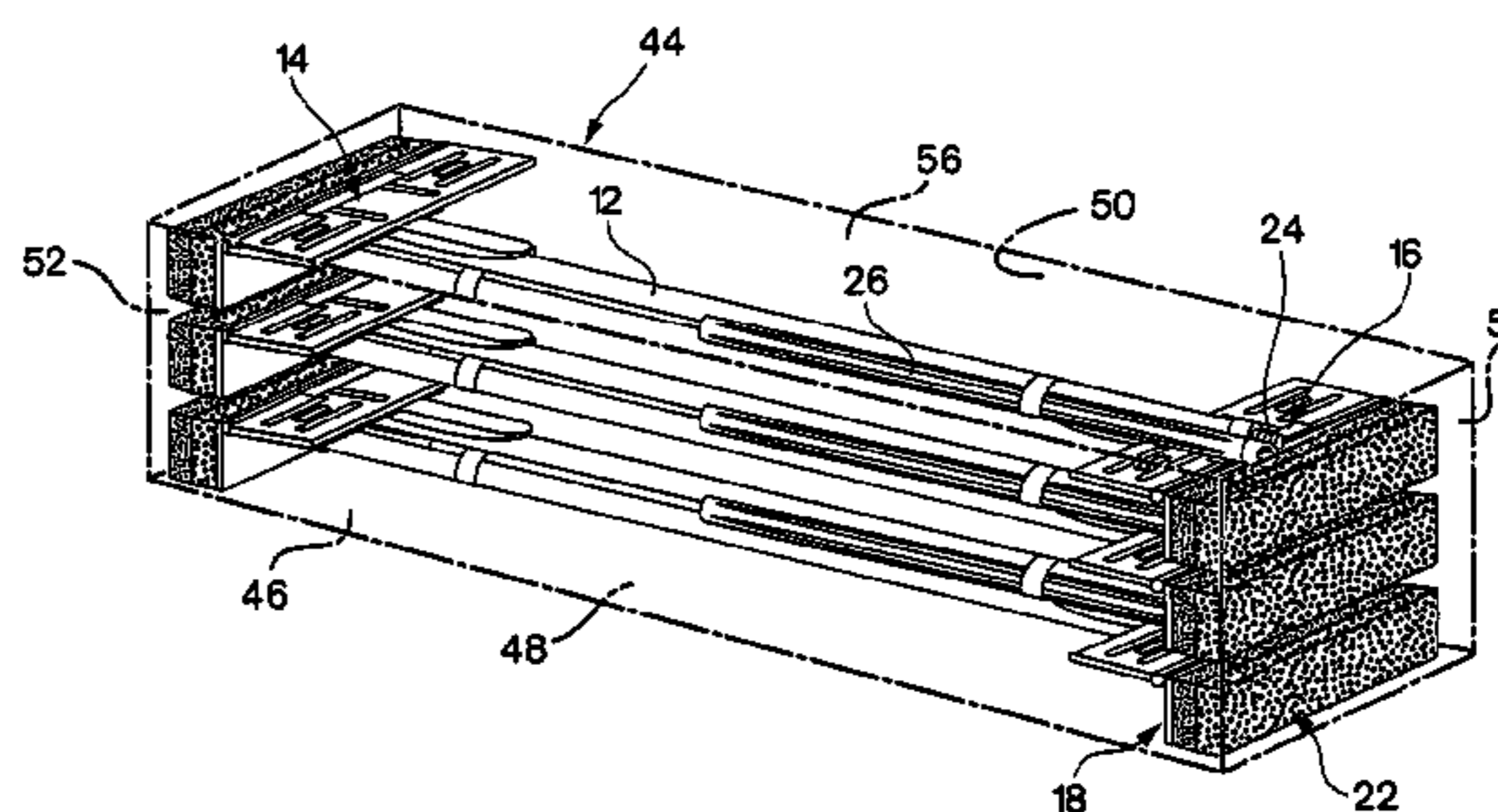
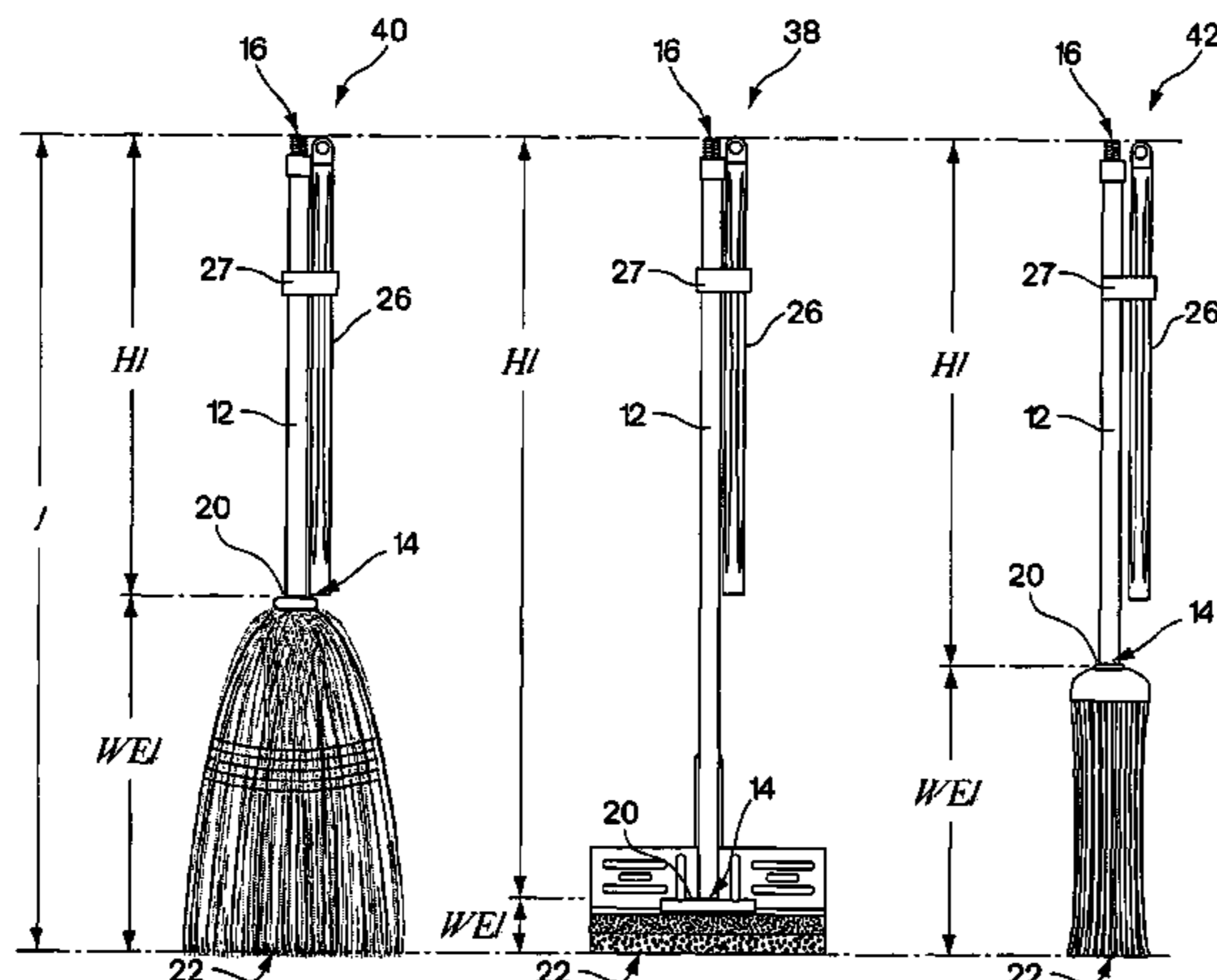

US 7,549,194 B2

Page 2

U.S. PATENT DOCUMENTS

4,769,869	A	9/1988	Benitez				
4,926,522	A	5/1990	Wang				
4,961,501	A *	10/1990	Hansmann	206/429		
4,971,374	A *	11/1990	Lovell et al.	292/339		
5,415,343	A *	5/1995	Vosbikian	229/162.3		
5,435,040	A	7/1995	McClure				
5,502,862	A	4/1996	Vosbikian				
D375,035	S	10/1996	Mangol				
5,573,115	A *	11/1996	Fuller	206/362.4		
5,606,761	A *	3/1997	Lynch	15/144.4		
5,609,255	A	3/1997	Nichols				
5,661,868	A	9/1997	Panagakos et al.				
5,743,580	A *	4/1998	Evans	294/51		
5,799,996	A *	9/1998	Fredrickson	294/51		
5,810,408	A	9/1998	Armstrong				
5,842,566	A *	12/1998	White	206/362		
5,887,314	A	3/1999	Jordan, Jr.				
5,943,727	A *	8/1999	Freer	15/144.1		
5,971,141	A	10/1999	Shafik				
6,134,743	A *	10/2000	Schmidt	15/236.01		
6,199,245	B1	3/2001	Blessing				
6,257,802	B1 *	7/2001	Vosbikian	405/259.3		
6,348,235	B1 *	2/2002	Cavill et al.	427/280		
6,439,630	B1 *	8/2002	Eatmon	294/51		
D463,961	S	10/2002	Hoshyla				
6,530,487	B1	3/2003	Berry				
6,581,776	B2 *	6/2003	Zatkoff	206/576		
D482,829	S *	11/2003	Vosbikian et al.	D32/45		
6,850,208	B1 *	2/2005	Ferrante	345/1.1		
6,865,776	B2 *	3/2005	Spinelli	16/110.1		
6,868,576	B2 *	3/2005	Petner	15/119.2		
6,902,060	B2 *	6/2005	Michelson et al.	206/576		
7,036,668	B2	5/2006	Udy				
7,040,493	B2	5/2006	Lin				
2003/0071075	A1 *	4/2003	Frankenbach et al.	222/383.1		
2003/0102010	A1 *	6/2003	Mays	134/6		
2003/0204926	A1	11/2003	Jurgens et al.				
2005/0023168	A1 *	2/2005	Marnocha	206/386		
2007/0090015	A1 *	4/2007	Chandaria	206/736		

OTHER PUBLICATIONS

Quickie Prod. No. 096—See attachment.
Quickie Prod. Nos. 001, 002 and 003—See attachment.
Quickie Prod. No. 012—See attachment.

* cited by examiner

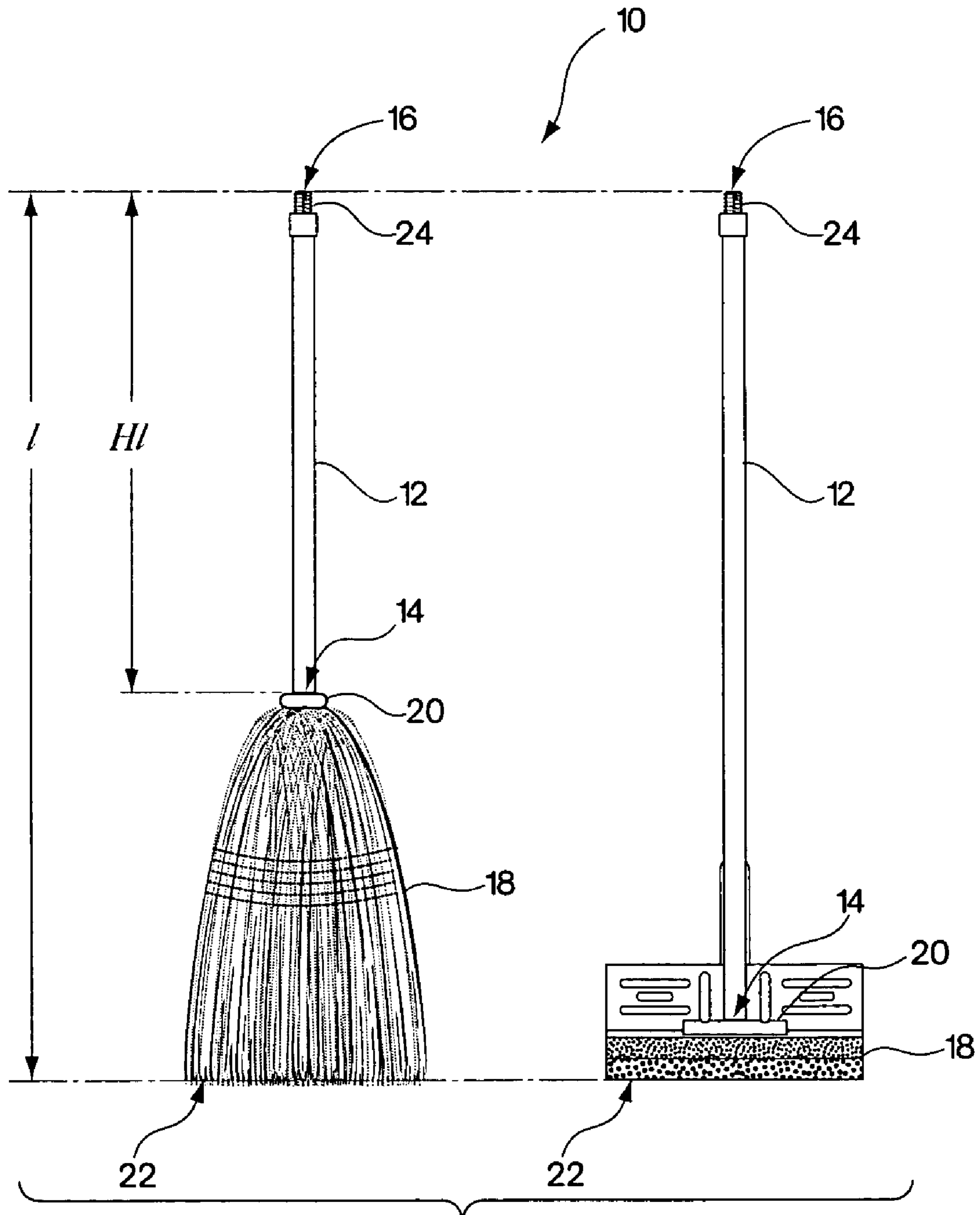

Fig. 1

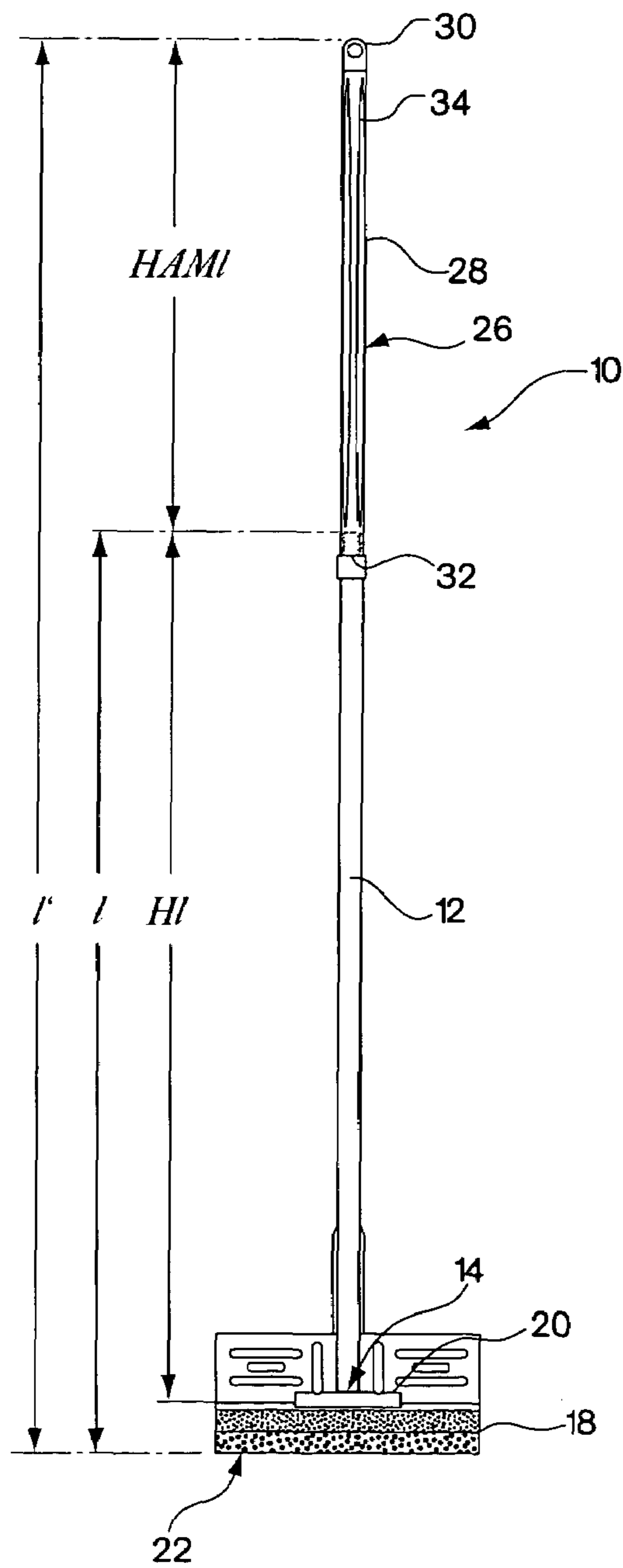

Fig. 2A

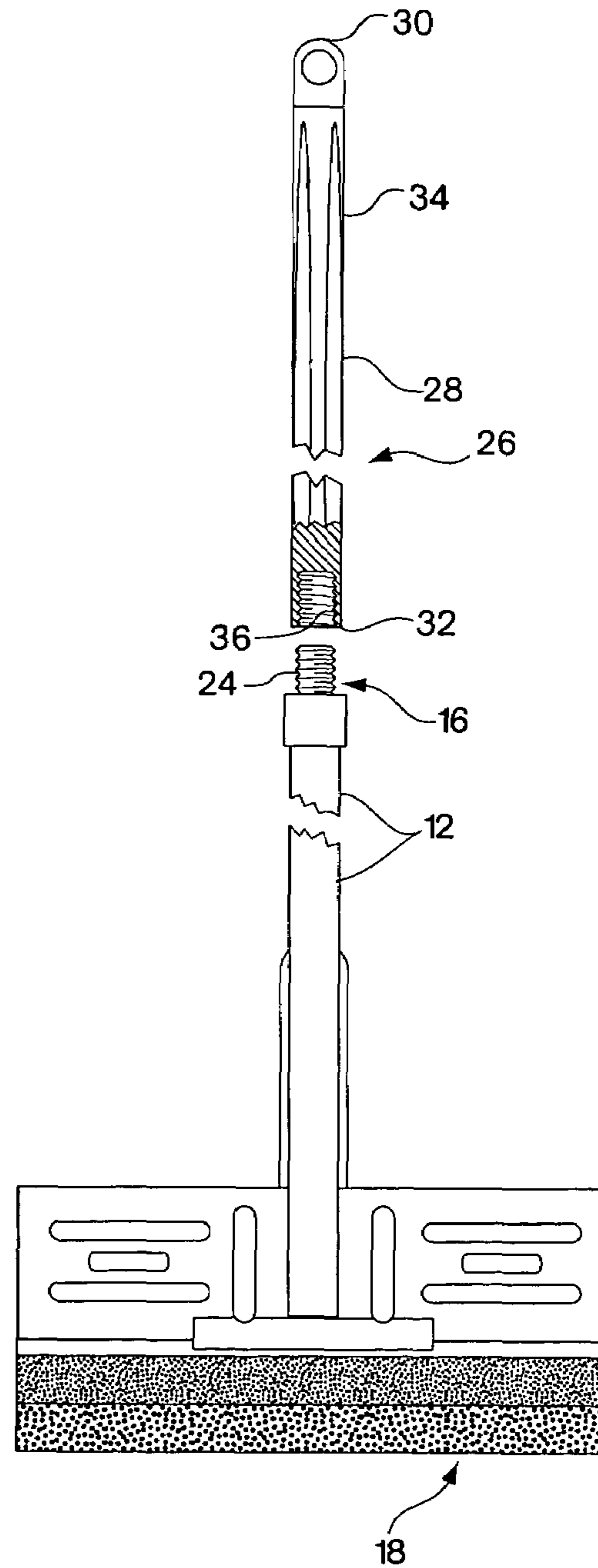

Fig. 2B

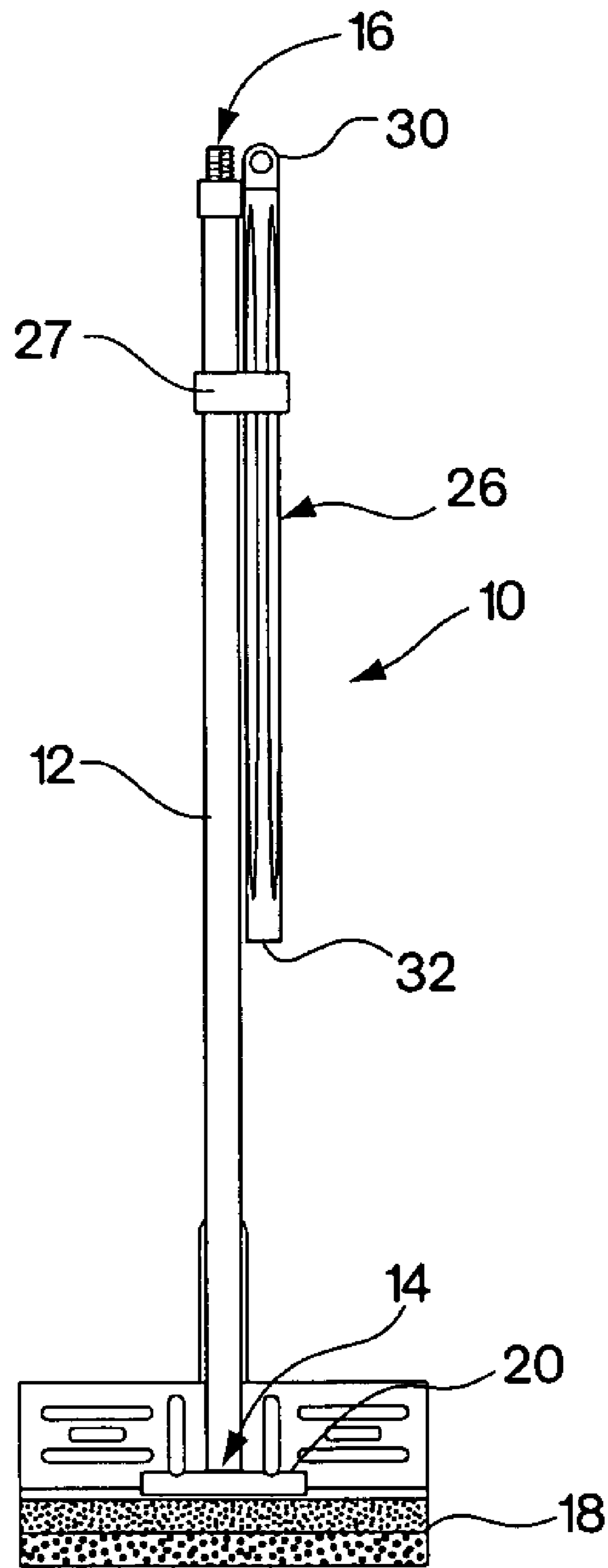

Fig. 3

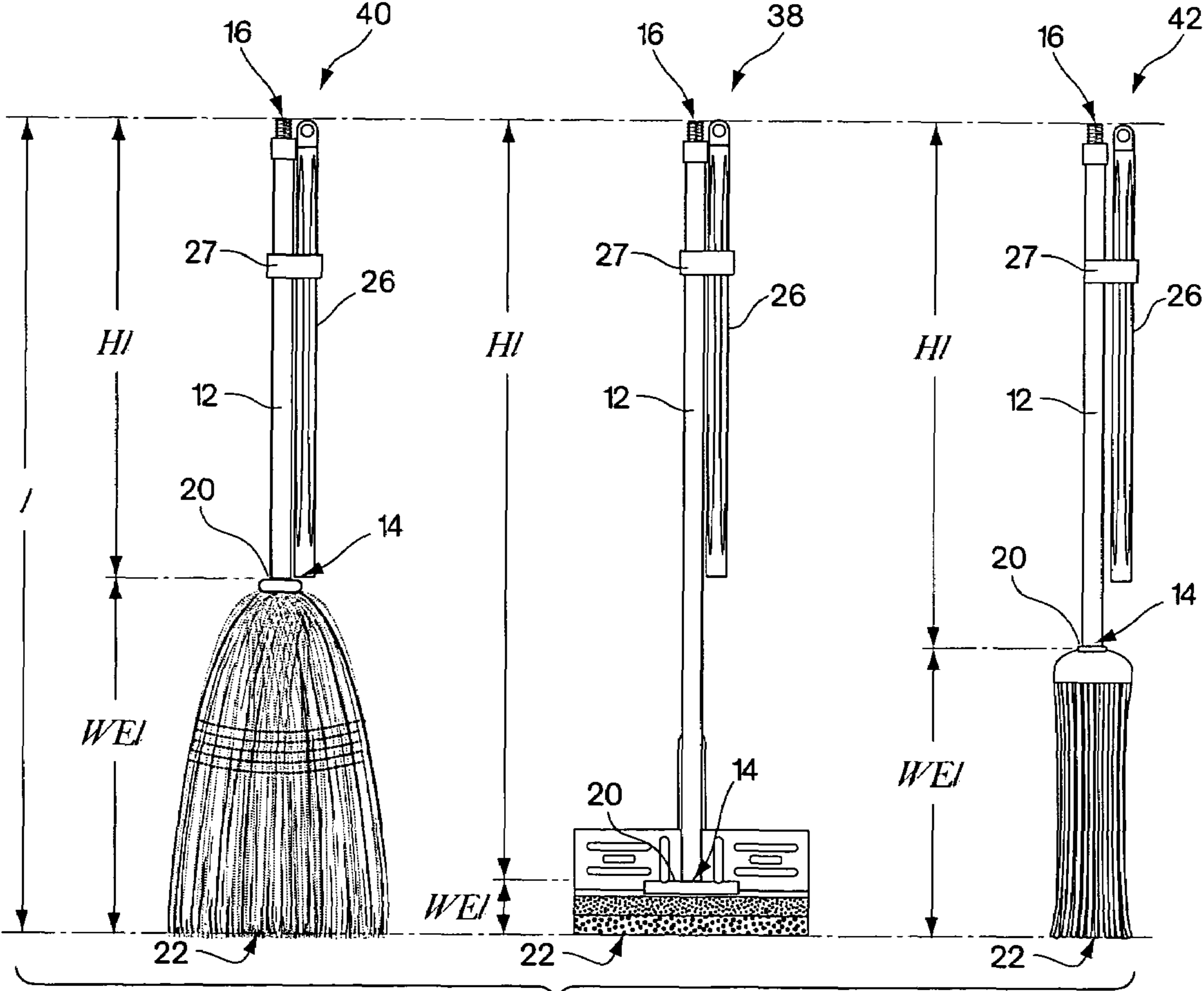

Fig. 4

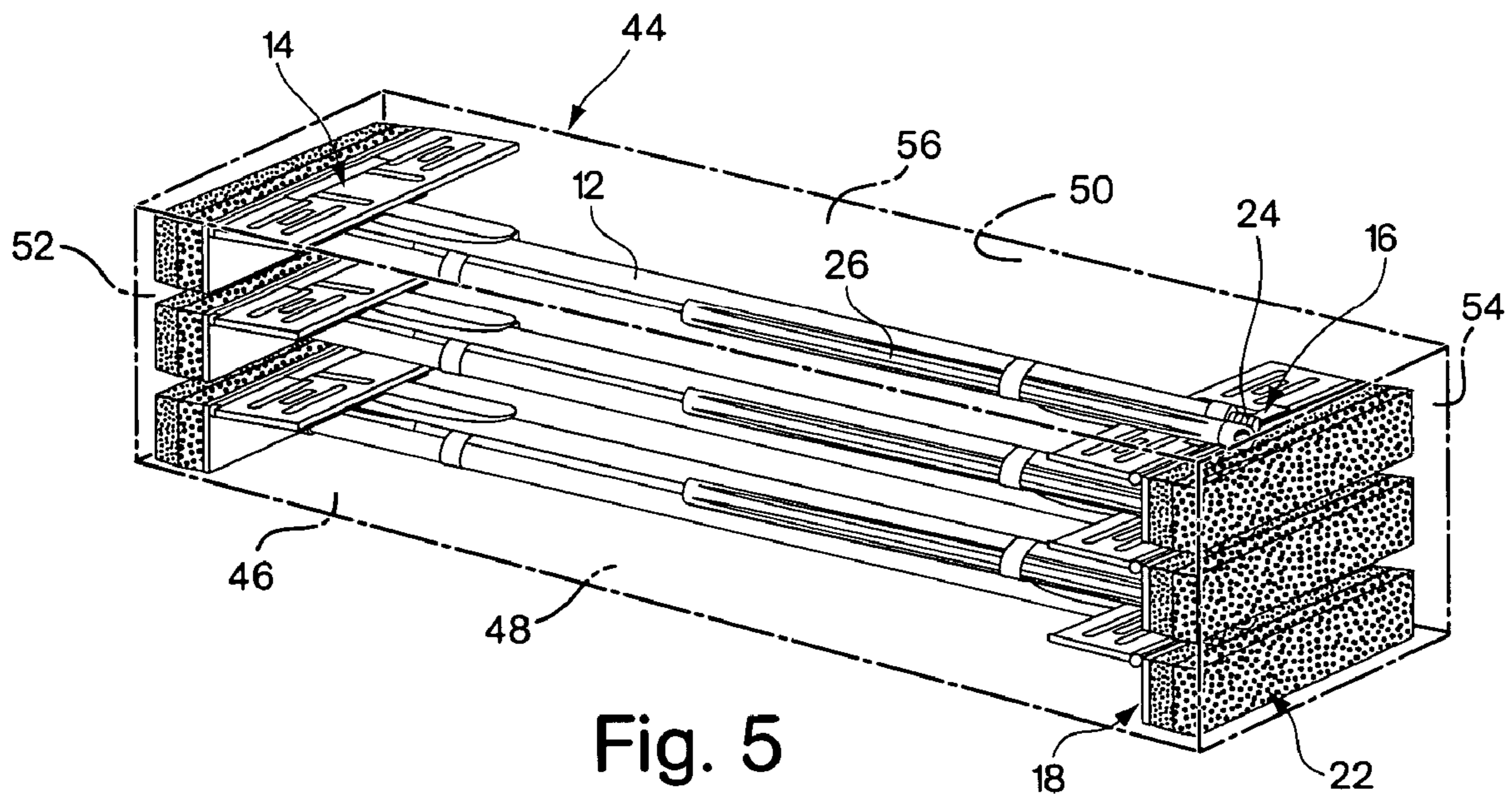
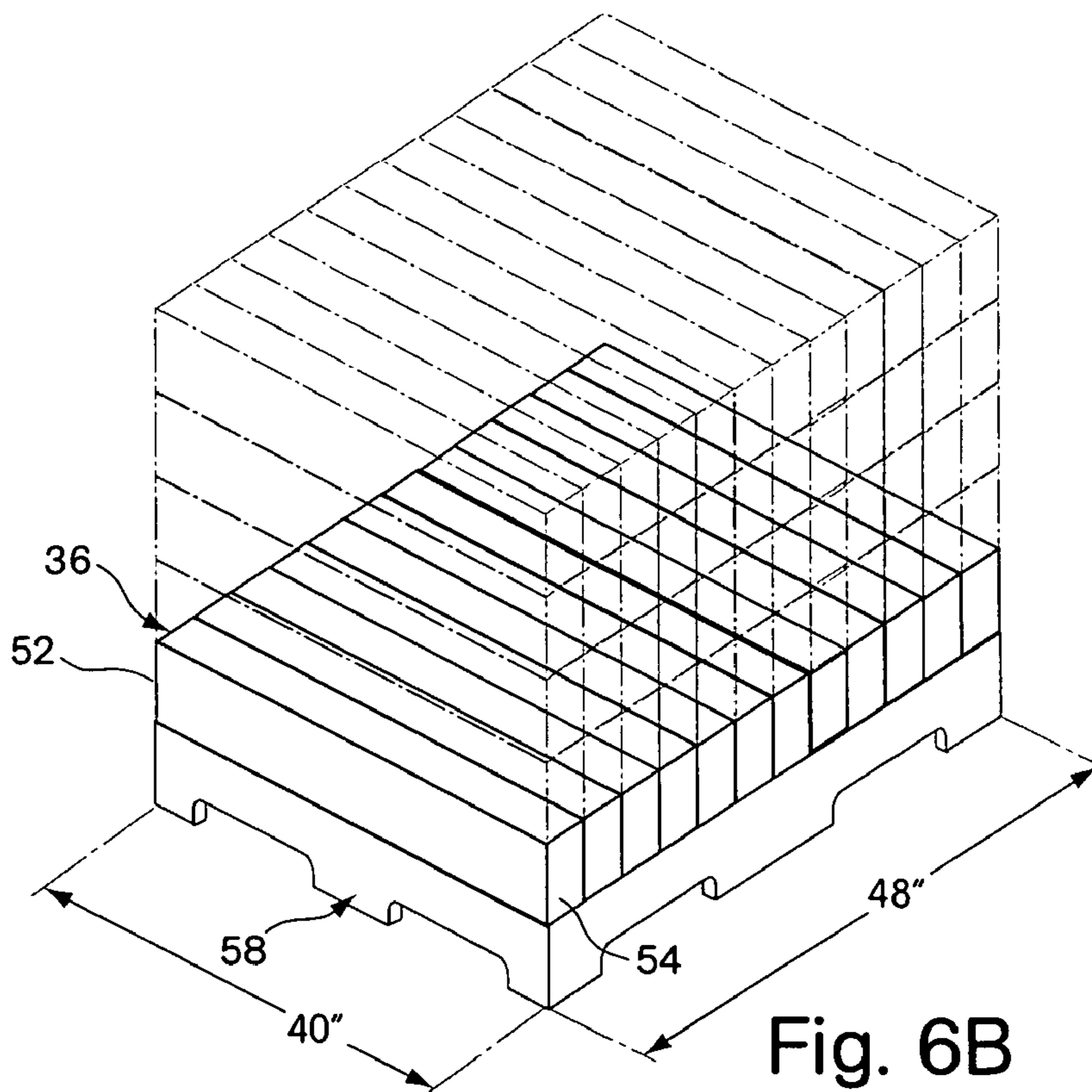
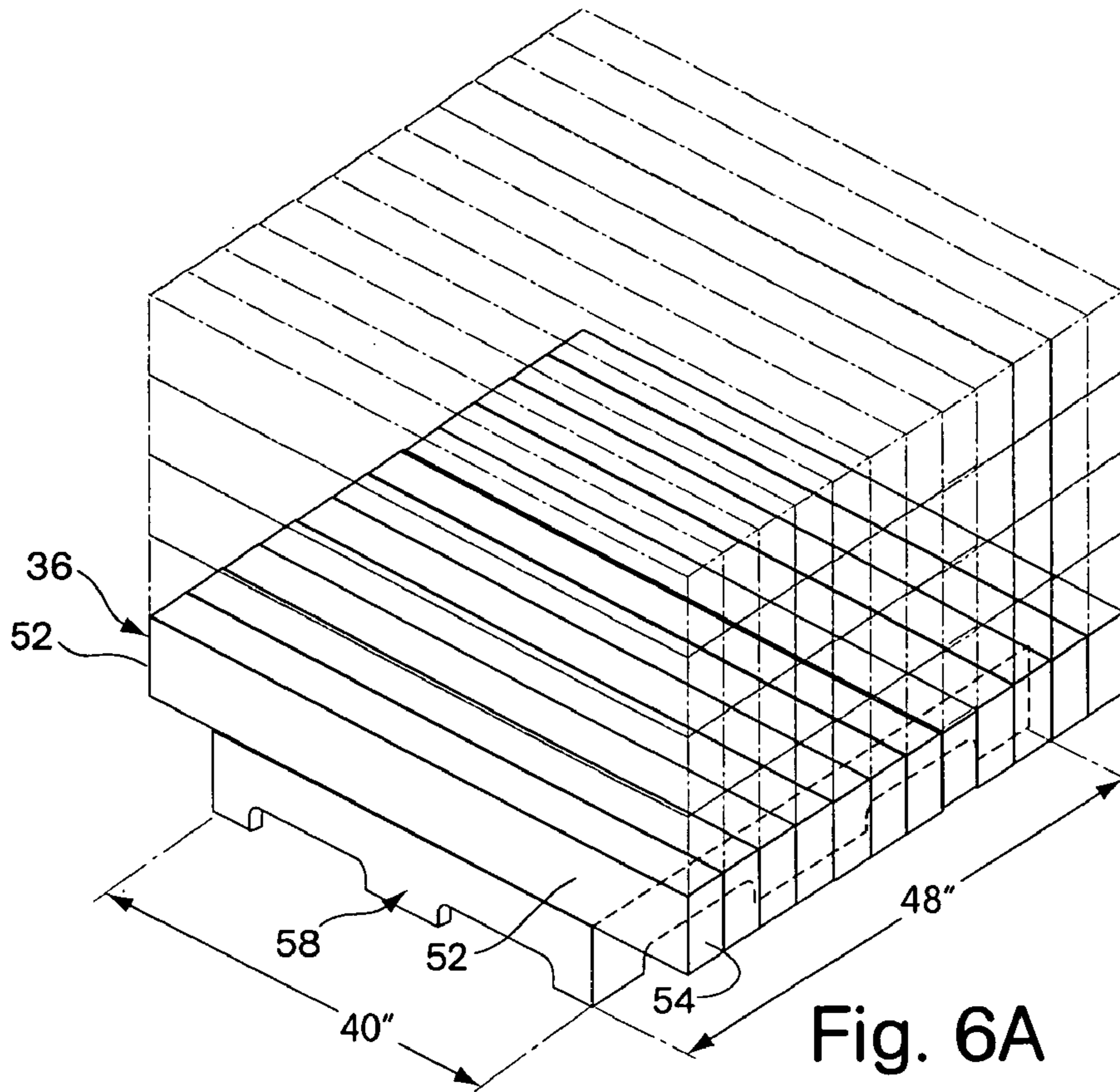

Fig. 5



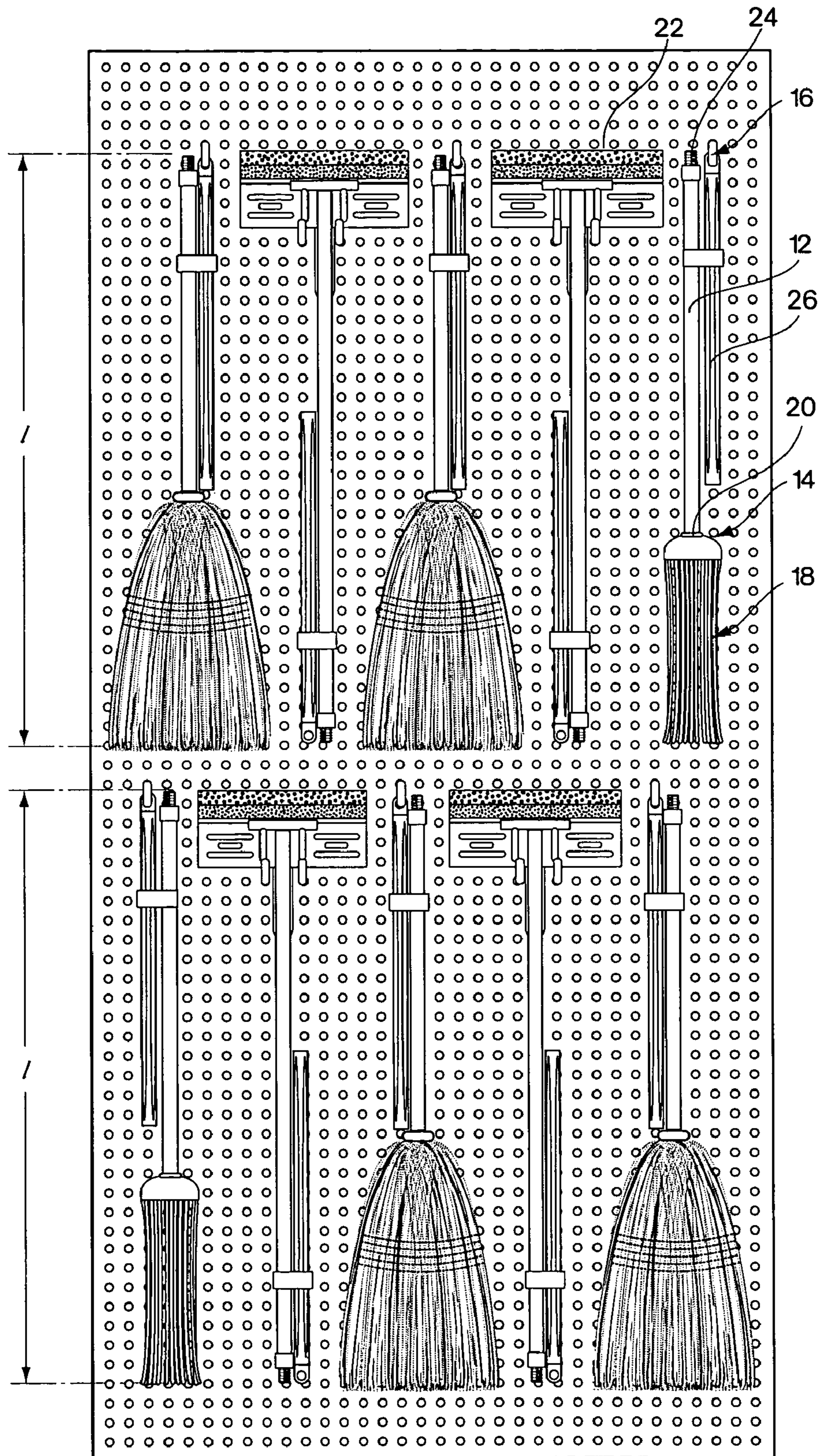

Fig. 7

1

**IMPLEMENTS WITH HANDLES AND
WORKING ENDS AND METHODS OF USE
THEREOF**

FIELD OF THE INVENTION

This invention relates to implements comprising handles and working ends, such as brooms or mops, and more particularly to methods of use for such implements.

SUMMARY OF THE INVENTION

Implements comprising handles and working ends are disclosed.

In one embodiment, an implement of the presently claimed invention comprises a handle including a first end and a second end, wherein a length extending between the first and second ends is within a range of about 15.0 inches to about 47.0 inches, and a working end including a top portion and a bottom portion, wherein the first end of the handle is attached to the top portion of the working end and a handle-attachment member adapted to extend the handle length, wherein the handle-attachment member includes a handle-attachment member length within a range of 12 inches to 20 inches.

In a second embodiment, the presently claimed invention is directed to a product line comprising a plurality of implements, in which each of the plurality of implements has a working end and a corresponding handle, wherein a relationship exists between two or more implements each having different working ends, such that as a length of the working end increases, the length of the corresponding handle decreases.

In a third embodiment, a method of the presently claimed invention comprises the steps of providing a plurality of implements, each comprising a handle and a working end, the handle including a first end and a second end and the working end including a top portion and a bottom portion, wherein the first end of the handle is attached to the top portion of the working end, wherein each of the implements includes substantially the same overall length, measured from the second end of the handle to the bottom portion of the working end, corresponding to a first length, and wherein the first length of the implements is extendable to a second length, providing a shipping container including a dimension adapted to receive the first length of the plurality of implements, placing the plurality of implements in the shipping container, and sending the shipping container to a destination.

In a fourth embodiment, a method of the presently claimed invention comprises the steps of providing a plurality of implements, each comprising a handle and a working end, the handle including a first end and a second end and the working end including a top portion and a bottom portion, wherein the first end of the handle is attached to the top portion of the working end, wherein each of the implements includes substantially the same length, measured from the second end of the handle to the bottom portion of the working end, corresponding to a first length within the range of about 20 inches to about 48 inches, and wherein the first length of the implements is extendable to a second length, providing a shipping container including a dimension adapted to accommodate the first length of the plurality of implements, placing the plurality of implements in the shipping container, wherein each of the plurality of implements are sized to the first length; and sending the shipping container to a destination.

In a fifth embodiment, a method of the presently claimed invention comprises the steps of providing a plurality of implements, each comprising a handle and a working end, the

2

handle including a first end and a second end and the working end including a top portion and a bottom portion, wherein two or more of the plurality of implements comprise different working ends and the first end of the handle is attached to a top portion of the working end and wherein each of the implements includes substantially the same length, corresponding to a first length, measured from the first end of the handle to the bottom portion of the working end, and displaying the plurality of implements in a row, wherein at least one of the second ends is substantially aligned with at least one of the bottom portions or another one of the second ends.

BRIEF DESCRIPTION OF THE DRAWINGS

Certain embodiments of the presently claimed invention are illustrated by the accompanying figures. It should be understood that the figures are not necessarily to scale and that details that are not necessary for an understanding of the invention or that render other details difficult to perceive may be omitted. It should be understood, of course, that the invention is not necessarily limited to the particular embodiments illustrated herein.

FIG. 1 is an elevated front view of two embodiments of the implements of the present invention;

FIG. 2A is an elevated front of one embodiment of the handle-attachment member and implement of the present invention;

FIG. 2B is an exploded cross-sectional view of the handle-attachment member and implement of FIG. 2A taken along line A-A of FIG. 2A;

FIG. 3 is an elevated front view of one embodiment of the implement of the present invention with handle-attachment member attached to a surface thereof;

FIG. 4 is an elevated front view of one embodiment of the product line of the present invention;

FIG. 5 is an elevated front view of one embodiment of the shipping container of the present invention;

FIG. 6A is a perspective view of a pallet housing multiple shipping containers;

FIG. 6B is a perspective view of one embodiment of a pallet of the present invention housing multiple shipping containers; and

FIG. 7 is an elevated front view of the cleaning implements of the present invention on display in a retail environment.

DETAILED DESCRIPTION

The present invention relates to implements comprising handles and working ends. The implements may, for example, be cleaning implements, such as mops, brooms, dusters, long-handled garden implements, such as rakes or garden hoes, or any other such implements. The term "working end," as used herein, means a portion of an implement attached to an end of a handle and capable of performing a function, such as the bristle portion on a broom or the sponge portion of a mop. The implements may be manufactured by methods known to those of skill in the art.

In accordance with one aspect of the present invention, a group of the implements, taken together, form a product line. The implements within the product line may exhibit a relationship between the lengths of their handles and working ends. As the working end length of an implement increases, the handle length typically decreases. The term "product line," as used herein, means a group of implements, two or more of which comprise different working ends.

In accordance with another aspect of the present invention, the implements may be used advantageously in various meth-

ods. In select embodiments, the implements may be used in both the shipping and retail contexts to save space and money.

Referring now to FIG. 1, two embodiments of the implements **10** of the present invention are shown. The embodiments of the implements **10** shown in FIG. 1 are cleaning implements comprising a handle **12**, which includes a first end **14** and a second end **16**, a working end **18**, which includes a top portion **20** and a bottom portion **22**. As shown in FIGS. 1A and 1B, the first end **14** of the handle **12** is attached to the top surface **20** of the working end **12** and the second end **16** of the handle **12** includes an externally threaded section **24**. The first end **14** of the handle **12** may be releasably securable to the top portion **20** of the working end **12** or may be affixed thereto. Optionally, a cap (not shown) may be employed to cover the externally threaded section **24**.

The distance from the second end **16** of the handle **12** to the bottom surface **22** of the working end **12**, corresponding to a first length *l*, is substantially the same for both cleaning implements **10**. In select embodiments of the present invention, the first length, *l*, may range from about 15.0 inches to about 50.0 inches, with a length of about 40.0 being typical.

The first length *l*, however, may be extended to a second length *l'*. The second length *l'* may range from about 37 inches to about 70 inches, depending on the type of implement being employed and the needs of the user. Another relevant measurement is the so-called handle length *Hl* corresponding to the length of the handle from the first end **14** to the second end **16**. The handle length, *Hl* is typically within the range of about 10.0 inches to about 45.0 inches.

In one embodiment, the first length *l* may be extended to a second length *l'* through a handle-attachment member **26**, shown in FIGS. 2A and 2B. The handle-attachment member **26** may comprise a grip. The handle-attachment member **26** of FIG. 2 comprises a hollow tube **28** with a rounded closed end **30**, an open end **32** and one or more flutes **34** disposed on a surface thereof. The handle-attachment member **26** is typically manufactured as an injection molded part. The handle-attachment member **26** may also be made from other materials, such as steel or wood.

The length of the handle-attachment member **26**—the handle-attachment member length *HAMI*—may range from about 12.0 inches to about 20.0 inches. When the length of the handle-attachment member, *HAMI* is within the range of about 12.0 inches and 15.0 inches, the handle length, *Hl* is typically between about 31.0 inches and about 47.0 inches. When the handle-attachment member length *HAMI* is between about 16.0 and 20.0 inches, the handle length is between about 10.0 inches and 30.0 inches.

Typically, the handle-attachment member **26** is releasably securable to the second end **16** of the handle **12** by an end-user. As shown in FIG. 2B, releasable securement may be accomplished by sliding the open end **32** of the handle-attachment member **26** over the second end **16** of the handle **12**. In FIG. 2B, the handle-attachment member **26** is releasably secured to the second end **16** of the handle **12** through an internally threaded section **36**, which mates with the externally threaded section **26** disposed on the first end **14** of the handle **12**. The handle-attachment member **26** may also be releasably secured to the first end **14** of the handle **12** through a friction or tight slide fit, a push and twist fit, a snap fit, a magnetic connection or any other releasably securable connection known to those of skill in the art.

The first length *l* may be extended to the second length *l'*, through various other means. A telescoping member, a living hinge disposed below the second end **16** of the handle **12** or any other device known to those of skill in the art may be employed for this purpose.

The handle-attachment member **26** may also be releasably secured to a surface of the handle **12** for shipment. As shown in FIG. 3, the handle-attachment member **26** may further comprise an annular clip **27** may be used to snap the handle-attachment member **26** to the surface of the handle **12**. Alternatively or additionally, the handle-attachment member **26** may be releasably secured to the surface of the handle **12** with shrink wrap, tape, a clamshell package, hot glue and a separate card attached to both and any other methods known to those of skill in the art.

Implements of the present invention may be grouped together into a product line. The product line typically comprises a group of implements with working ends designed for similar purposes, such as cleaning implements or garden implements. Referring now to FIG. 4, for example, a product line including a mop **38**, broom **40** and wet mop **42** are shown. Product lines including a variety of working end types may of course be employed. A product line of garden implements may include hoe and rake working ends.

Implements within the product line may each include a working end and a corresponding handle, wherein a relationship exists between two or more implements each having different working ends, such that as a length of the working end increases, the length of the corresponding handle decreases. The implement includes a handle length *Hl* and a working end length *WEI*. The handle length *Hl* measured from the first end **14** of the handle **12** to the second end **16** of the handle **12** may range from about 15.0 inches to 45.0 inches and the working end length *WEI*, measured from the top portion **20** of the working end **18** to the bottom portion **22** of the working end **18**, is typically less than 15.0 inches. As demonstrated in FIG. 4, as the working end length *WEI* of the working end increases, the length of the corresponding handle decreases.

In certain embodiments, the overall length of each of the plurality of implements, described herein as the first length *l* and calculated by adding the handle length *Hl* to the working end length *WEI*, is substantially the same or standardized. The first length *l* may range from about 20.0 inches to about 50.0 inches. As described hereinabove, however, a handle-attachment member **26** may be releasably secured to the handle **12** by a user interested in increasing the first length *l* of one or more of the implements to a second length *l'*, shown at FIGS. 2A & 2B.

In another aspect, implements of the present invention may be shipped in various configurations to a destination. The shipping methods of the present invention seek to save costs and maximize use of available shipping space.

In one embodiment, the shipping method comprises shipment of a plurality of implements, all of which include substantially the same length (the first length *l*). Referring now to FIG. 5, an embodiment of a shipping container **36** of the present invention, holding the plurality of implements, is shown. Each implement **10** of FIG. 5 comprises the handle **12** having the first end **14** and the second end **16** and the working end **18** having the top surface **20** and the bottom surface **22**. The first end **14** of the handle **12** is attached to the top surface **20** of the working end **18**.

As previously mentioned, each of the implements in the shipping method includes substantially the same length, measured from the second end **16** of the handle **12** to the bottom surface **22** of the working end **18**—designated as the first length *l*, on FIGS. 1 and 2. This first length *l* is extendable to the second length *l'* by a user.

The shipping method generally involves a number of steps, the order of which may be altered, depending on the needs of the user.

5

First, the shipping container **44** is provided. As shown in FIG. **5**, the shipping container **44** includes a dimension adapted to receive the first length *l* of the plurality of implements. Typically, the dimension is just large enough to allow the first length of the implements to fit within the container. Most often, the dimension is about 1.0 inch larger than the first length *l* of the implements being shipped. As shown in FIG. **5**, the shipping container may be a corrugated cardboard box comprising a base **46**, front and back sidewalls **48** and **50**, left and right sidewalls **52** and **54** and a top **56** that can be opened and closed by a user. The shipping container **44** of the present invention may be a box that ranges in size from 40.0 inches by 4.0 inches by 2.0 inches to 40.0 inches by 48.0 inches by 48.0 inches, but is typically about 40.0 inches by 10.0 inches by 10.0 inches. Depending on the dimensions of the boxes, a number of implements may be placed within. In a box that is 40.0 inches by 12.0 inches by 8.0 inches, about 12 or less implements may be placed within. In boxes with larger dimensions, more implements may be placed within.

Second, the implements, all of which include substantially the same length, are placed within the shipping container **44**. In general, the plurality of implements are all sized to the first length *l*. In some embodiments, one or more handle-attachment members **26** may be secured to a side of the handle **12** during shipment. After shipment, the handle-attachment members **26** may be employed by end-users to extend the first length *l* to the second length *l'*. In other embodiments, two or more of the implements include different working ends. For example, brooms may be shipped with mops or long-handled garden implements with rakes.

Third, two or more of the shipping containers **36** may be placed on a pallet **58**. The typical dimensions of the pallet **58** include 48.0 inches by 40.0 inches. As shown in FIG. **6A**, when shipping containers include lengths over 48.0 inches, for example between 48 and 62 inches, the ends of the shipping containers hang over the edges of the pallet. This leads to potential damage to the implements within the shipping containers and occupies unnecessary space in a warehouse or truck. When fork lift operators pick up the pallets, the shipping containers overhanging the pallets may be crushed when the pallets are repositioned against a wall in a warehouse. Importantly, all prior art methods for shipping implement product lines have included the use of at least some shipping containers longer than 48.0 inches. In many cases, based on the length of the implements in the line, shipping containers with lengths above 48.0 inches was the norm.

On the other hand, in accordance with one embodiment of the present invention, when implements are standardized to include an overall length of about 39.0 inches, the shipping containers may be standardized to include a length of 40.0 inches. As shown in FIG. **6B**, under these circumstances, the shipping containers do not overhang the edge of the pallet and a large space savings is achieved. For example, comparing one embodiment of the shipping container of the present invention, including dimensions of 40.0 inches by 10.0 inches by 10.0 inches with the shipping container of **6A**, having dimensions of 55.0 inches by 10.0 inches by 10.0 inches, a space savings of approximately 30% is seen. More specifically, the shipping container of the present invention occupies a space of 4,000 (40×10×10) cubic inches, while the shipping container of FIG. **6A** occupies a space of 5,500 (55×10×10) cubic inches. Dividing the 1,500 cubic inch difference by 5,500 yields a space savings of 27.2%.

In addition, through use of the instant invention, increased numbers of shipping containers may be shipped on a single standardized pallet, depending on their orientation. For example, assuming the shipping containers **36** are 8.0 inches

6

by 40.0 inches, when the left and right sidewalls **52** and **54** of the shipping containers **36** are perpendicular to the 40.0 inch portion of the pallet **58**, six shipping containers fit across the 48.0 inch portion of the single standardized pallet. If, however, some of the shipping containers **36** are more than 40.0 inches long (to receive implements with overall lengths more than 40 inches), the left and right sidewalls **52** and **54** of the shipping container **36** may be perpendicular to the 48.0 inch portion of the pallet and only 5 shipping containers fit across the 40.0 inch section of the pallet.

In yet another aspect, implements of the present invention may be displayed, most often in a retail environment. The method of display may be helpful in maximizing the number of implements displayed in a way that is aesthetically pleasing to consumers.

In one embodiment, shown in FIG. **7**, a plurality of implements are displayed on a two-tiered board in a retail environment. Each implement comprises a handle **12**, which includes a first end **14** and a second end **16** and a working end **18**, which includes a top surface **20** and a bottom surface **22**. As shown in FIG. **7**, the first length *l* of each implement, measured from the second end **16** of the handle **12** to the bottom surface **22** of the working end **18** is substantially the same. The first length *l* may be extended by a user through a handle-attachment member **26** or the other above-described methods. As further shown in FIG. **7**, the implements are hung from hooks in an alternating pattern, such that, the second end **16** of each handle **12** is aligned with the bottom portion **22** of each adjacent implement. This type of arrangement not only saves space, particularly when adjacent implements are displayed as close as possible to one another, but is aesthetically pleasing to consumers.

Variations, modifications and other implementations of what is described herein will occur to those of ordinary skill in the art without departing from the spirit and scope of the invention. Accordingly, the invention is in no way limited by the preceding illustrative description.

We claim:

1. A method of packing a shipping container with a plurality of implements comprising the steps of:

providing a plurality of implements, each implement comprising a handle attached to a working end, the handle including a first end and a second end, wherein the working end comprises a portion which is configured to perform a cleaning function and another portion attached to the first end of the handle, wherein each of the implements includes substantially a same first length comprising a distance from a bottom surface of the working end to the second end of the handle, and a handle-attachment member releasably securable to the second end of the handle;

providing a shipping container; and

disposing the plurality of implements, with the handle-attachment members detached from the second ends of the handles, within the shipping container so that at least one working end is aligned with at least one of another working end and a second end of another implement.

2. The method of claim **1**, wherein the implements are selected from the group consisting of mops, brooms and dusters, long-handled garden implements and rakes.

3. The method of claim **1**, wherein two or more of the implements comprise different working ends.

4. The method of claim **1**, wherein the handle-attachment member is adapted to extend the implement to a second length comprising a second distance from the bottom surface of the working end to a top end of the handle-attachment member.

7

5. The method of claim 4, wherein the handle-attachment member ranges in length from about 12 inches to about 20 inches.

6. The method of claim 4, wherein the handle-attachment member comprises a treaded section for mating with a treaded section disposed on the second end of the handle.

7. The method of claim 4, wherein the second length is 70 inches or less.

8. The method of claim 4, wherein the second length is in a range between 37 inches to 70 inches.

9. The method of claim 1, further comprising attaching the handle-attachment members to side surfaces of the handles before the disposing step.

10. The method of claim 9, wherein the handle-attachment members are clipped to the side surfaces of the handles.

11. The method of claim 1, wherein a length dimension of each shipping container is no greater than about 40.0 inches.

12. The method of claim 1, further comprising placing the shipping container on a pallet.

13. The method of claim 12, wherein a lengthwise dimension of the pallet is about 40.0 inches.

14. The method of claim 1, wherein during the disposing step at least one working end is aligned with at least one second end.

15. The method of claim 1, wherein during the disposing step said at least one working end is vertically aligned with said at least one of another working end and said second end of another implement.

16. The method of claim 1, wherein during the disposing step the implements are stacked within the shipping container.

17. The method of claim 1, wherein during the disposing step the handles of the implements are aligned in a parallel formation within the shipping container.

8

18. The method of claim 1, wherein after the disposing step the bottom surface of the working end is near one end of the shipping container and the second end of the handle is near an opposite end of the shipping container.

19. The method of claim 1, wherein a wall dimension of the shipping container is sized just larger than the first length.

20. The method of claim 19, wherein during the disposing step the handle is disposed along the wall dimension of the shipping container.

21. The method of claim 1, further comprising the steps of providing a plurality of shipping containers and disposing a plurality of implements sized to substantially the same first length within each shipping container.

22. The method of claim 21, further comprising the step of disposing the plurality of shipping containers on a pallet.

23. The method of claim 22, further comprising the step of sending the pallet to a destination.

24. The method of claim 1, wherein the first length is within a range of about 40 inches to about 48 inches.

25. The method of claim 1, wherein a length dimension of each shipping container is no greater than about 48.0 inches.

26. The method of claim 1, wherein during the disposing step at least one working end is aligned with another working end.

27. The method of claim 1, wherein the working end comprises at least one of a portion of a mop, a portion of a broom, a portion of a duster, and a portion of a rake.

28. The method of claim 1, wherein the handle-attachment member is adapted to be attached to the second end of the handle in a parallel alignment to extend the handle.

* * * * *