



US007535458B2

(12) **United States Patent**
Farag et al.

(10) **Patent No.:** **US 7,535,458 B2**
(45) **Date of Patent:** ***May 19, 2009**

(54) **MULTI-BUTTON MOUSE**

(75) Inventors: **Abraham Farag**, East Palo Alto, CA (US); **Brian Huppi**, San Carlos, CA (US)

(73) Assignee: **Apple Inc.**, Cupertino, CA (US)

(*) Notice: Subject to any disclaimer, the term of this patent is extended or adjusted under 35 U.S.C. 154(b) by 0 days.

This patent is subject to a terminal disclaimer.

5,339,213 A	8/1994	O'Callaghan
5,414,445 A	5/1995	Kaneko et al.
5,438,331 A	8/1995	Gilligan et al.
D362,431 S	9/1995	Kaneko et al.
5,473,343 A	12/1995	Kimmich et al.
5,473,344 A	12/1995	Bacon et al.
5,495,566 A	2/1996	Kwatinetz

(Continued)

FOREIGN PATENT DOCUMENTS

(21) Appl. No.: **11/748,273**

DE 19722636 12/1998

(22) Filed: **May 14, 2007**

(65) **Prior Publication Data**

US 2007/0211033 A1 Sep. 13, 2007

(Continued)

OTHER PUBLICATIONS

Related U.S. Application Data

(63) Continuation of application No. 10/209,537, filed on Jul. 30, 2002, now Pat. No. 7,233,318.

(60) Provisional application No. 60/364,400, filed on Mar. 13, 2002.

(51) **Int. Cl.**
G09G 5/08 (2006.01)

(52) **U.S. Cl.** **345/163**

(58) **Field of Classification Search** 345/156, 345/157, 163-166; D14/402-410

See application file for complete search history.

Gadgetboy, "Point and click with the latest mice", CNET Asia Product Review, www.asia.cnet.com/reviews...are/gadgetboy/0,39001770,38023592,00.htm, downloaded Dec. 5, 2001.

(Continued)

Primary Examiner—Richard Hjerpe
Assistant Examiner—Tom V Sheng
(74) *Attorney, Agent, or Firm*—Beyer Law Group LLP

(56) **References Cited**

U.S. PATENT DOCUMENTS

4,866,602 A	9/1989	Hall
4,917,516 A	4/1990	Retter
5,125,077 A	6/1992	Hall
5,179,648 A	1/1993	Hauck
5,237,311 A	8/1993	Mailey et al.
D349,280 S	8/1994	Kaneko

(57) **ABSTRACT**

A mouse with multi button functionality is disclosed. The mouse includes a housing that surrounds the internal components of the mouse. The housing includes at least a first member and a second member, each of which forms a substantial portion of the housing. The first member moves relative to the second member so as to implement at least one of the multiple button functions of the mouse.

28 Claims, 11 Drawing Sheets

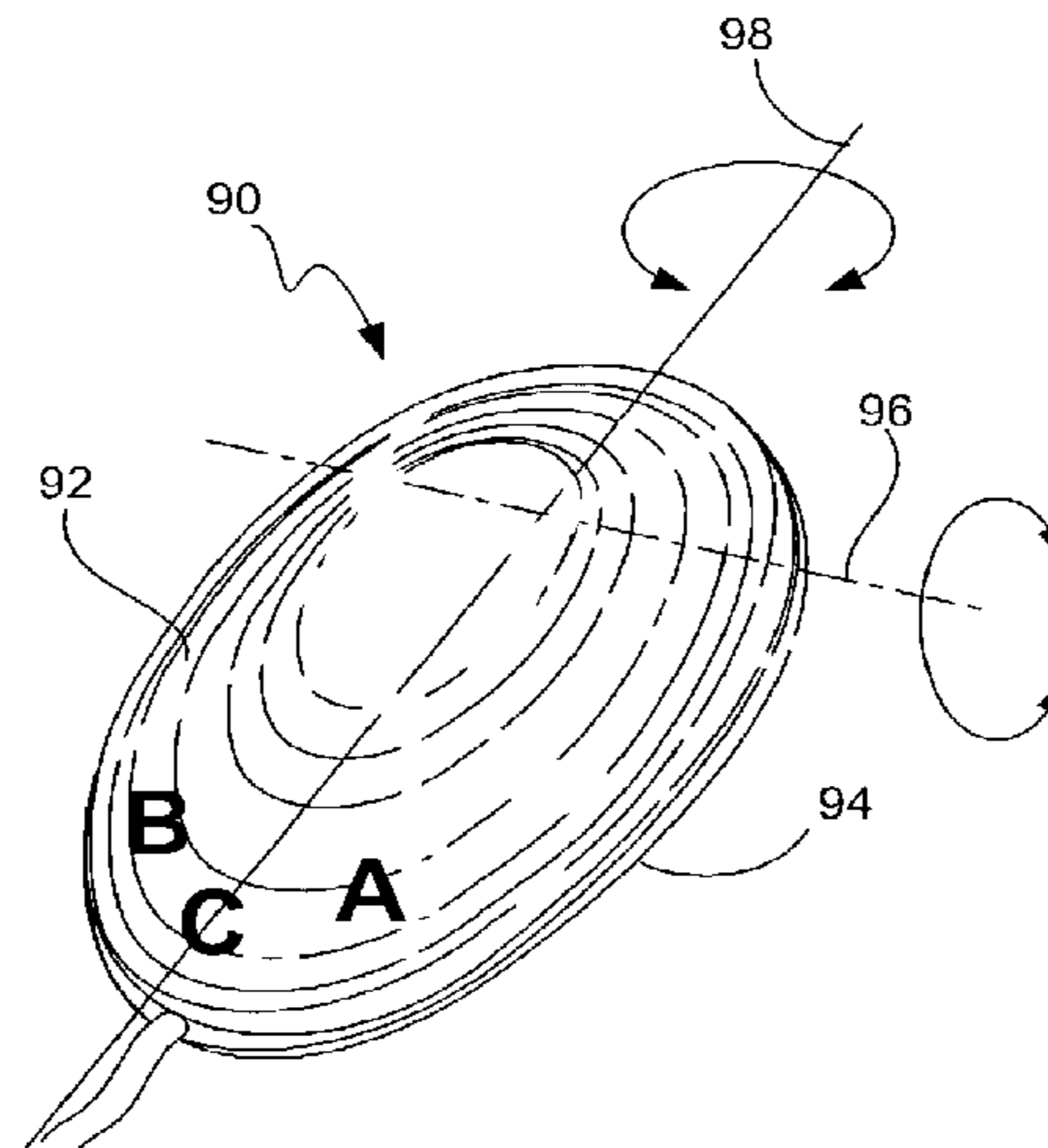

U.S. PATENT DOCUMENTS

5,528,265 A 6/1996 Harrison
 5,559,943 A 9/1996 Cyr et al.
 5,561,445 A 10/1996 Michio et al.
 5,565,887 A 10/1996 McCambridge et al.
 5,578,817 A 11/1996 Bidiville et al.
 5,596,347 A 1/1997 Robertson et al.
 5,598,183 A 1/1997 Robertson et al.
 5,611,040 A 3/1997 Brewer et al.
 5,611,060 A 3/1997 Belfiore et al.
 D382,550 S 8/1997 Kaneko et al.
 D385,542 S 10/1997 Kaneko et al.
 5,726,687 A 3/1998 Belfiore et al.
 5,751,274 A 5/1998 Davis
 5,754,890 A 5/1998 Holmdahl et al.
 5,786,818 A 7/1998 Brewer et al.
 5,808,602 A 9/1998 Sellers
 5,825,353 A 10/1998 Will
 5,828,364 A 10/1998 Siddiqui
 5,838,304 A 11/1998 Hall
 D402,281 S 12/1998 Ledbetter et al.
 5,883,619 A 3/1999 Hoe et al.
 5,907,152 A 5/1999 Dändliker et al.
 5,907,318 A 5/1999 Medina
 6,005,299 A 12/1999 Hengst
 6,031,518 A 2/2000 Adams et al.
 6,064,370 A 5/2000 Wang et al.
 6,075,533 A 6/2000 Chang
 6,084,574 A 7/2000 Bidiville
 6,097,372 A 8/2000 Suzuki
 6,115,028 A 9/2000 Balakrishnan et al.
 6,128,006 A 10/2000 Rosenberg et al.
 6,130,664 A 10/2000 Suzuki
 6,163,312 A 12/2000 Furuya
 6,166,721 A 12/2000 Kuroiwa et al.
 6,179,496 B1 1/2001 Chou
 6,181,322 B1 1/2001 Nanavati
 6,188,393 B1 2/2001 Shu
 6,191,774 B1 2/2001 Schena et al.
 6,198,473 B1 3/2001 Armstrong
 6,211,861 B1 4/2001 Rosenberg
 D442,592 S 5/2001 Ledbetter et al.
 D443,616 S 6/2001 Fisher et al.
 6,243,078 B1 6/2001 Rosenberg
 6,256,011 B1 7/2001 Culver
 6,333,734 B1 12/2001 Rein
 6,356,524 B2 3/2002 Aranti
 6,369,797 B1 4/2002 Maynard, Jr.
 6,373,470 B1 * 4/2002 Andre et al. 345/166
 6,377,530 B1 4/2002 Burrows
 6,392,634 B1 5/2002 Bowers et al.
 6,429,852 B1 8/2002 Adams et al.
 6,587,091 B2 7/2003 Serpa
 6,608,616 B2 8/2003 Lin
 6,639,584 B1 10/2003 Li
 6,686,904 B1 2/2004 Sherman et al.
 6,700,564 B2 3/2004 McLoone et al.
 6,724,817 B1 4/2004 Simpson et al.
 6,727,889 B2 4/2004 Shaw

6,738,045 B2 5/2004 Hinckley et al.
 6,788,288 B2 9/2004 Ano
 6,795,057 B2 * 9/2004 Gordon 345/163
 6,828,958 B2 * 12/2004 Davenport 345/163
 6,844,871 B1 1/2005 Hinckley et al.
 6,844,872 B1 * 1/2005 Farag et al. 345/163
 7,051,291 B2 5/2006 Sciammarella et al.
 7,084,856 B2 8/2006 Huppi
 7,142,193 B2 11/2006 Hayama et al.
 7,164,412 B2 * 1/2007 Kao 345/163
 7,239,800 B2 7/2007 Bilbrey
 7,312,785 B2 12/2007 Tsuk et al.
 7,345,671 B2 3/2008 Robbin et al.
 2001/0011991 A1 8/2001 Wang et al.
 2002/0140676 A1 * 10/2002 Kao 345/163
 2003/0076306 A1 4/2003 Zadesky et al.
 2003/0107551 A1 6/2003 Dunker
 2003/0107552 A1 6/2003 Lu

FOREIGN PATENT DOCUMENTS

DE 10022537 11/2000
 EP 0 498 540 A2 1/1992
 EP 0 880 091 A2 11/1998
 EP 1 026 713 A1 8/2000
 JP 03-237520 10/1991
 JP 11-194863 7/1999
 JP 11-194872 7/1999
 JP 11-194883 7/1999
 JP 2000-215549 8/2000
 JP 2001-051790 2/2001
 WO WO 94/17494 8/1994
 WO WO 98/14863 4/1998
 WO WO 99/49443 9/1999

OTHER PUBLICATIONS

“Product Overview—SpaceMouse® Classic”, www.logicad3d.com/products/Classic.htm, downloaded Apr. 8, 2002.
 “Product Overview—ErgoCommander®”, www.logicad3d.com/products/ErgoCommander.htm, downloaded Apr. 8, 2002.
 “About Quicktip®” www.logicad3d.com/docs/qt.html, downloaded Apr. 8, 2002.
 “System Service and Troubleshooting Manual”, www.dsplib.com/intv/Master, downloaded Dec. 11, 2002.
 “Der Klangmeister,” Connect Magazine, Aug. 1998.
 Bang & Olufsen Telecom a/s, “BeoCom 6000 User Guide 2000”.
 Chapweske, Adam, “PS/2 Mouse/Keyboard Protocol”, 1999, <http://panda.cs.ndsu.nodak.edu/~achapwes/PICmicro/PS2/ps2.htm>.
 Letter re: Bang & Olufsen A/S, by David Safran, Nixon Peabody, LLP, May 21, 2004.
 Marriott et al., U.S. Appl. No. 10/722,948, filed Nov. 25, 2003.
 Photographs of Innovations 2000 Best of Show award presented at the 2000 International CES Innovations 2000 Design & Engineering Showcase, 1 pg.
 Sylvania, “Intellivision™ Intelligent Television Master Component Service Manual,” pp. 1, 2 and 8, 1979.
 Kevin De Meyer, Crystal Optical Mouse, Feb. 14, 2002, Heatseekrz, Web Article 19.

* cited by examiner

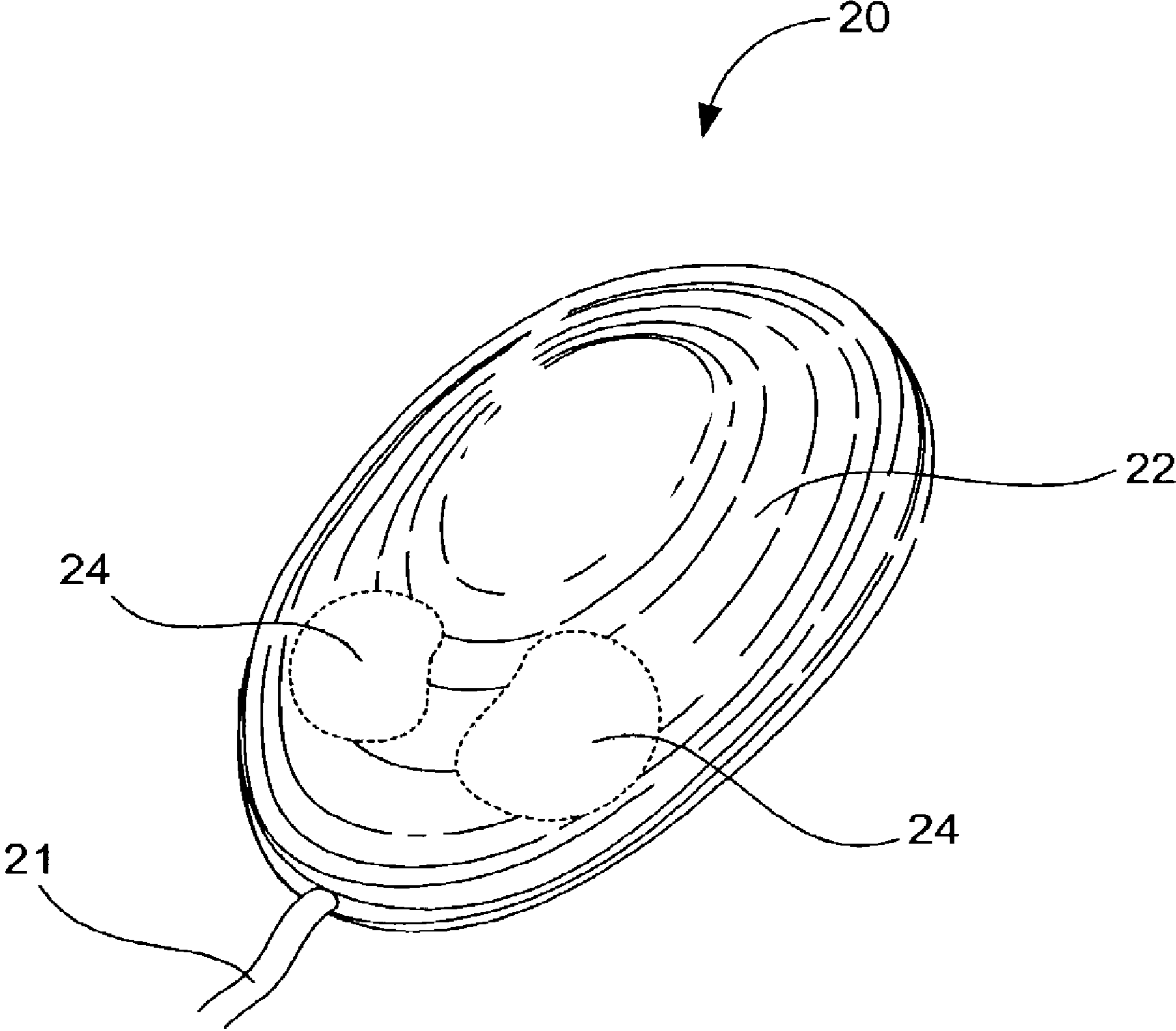

FIG. 1

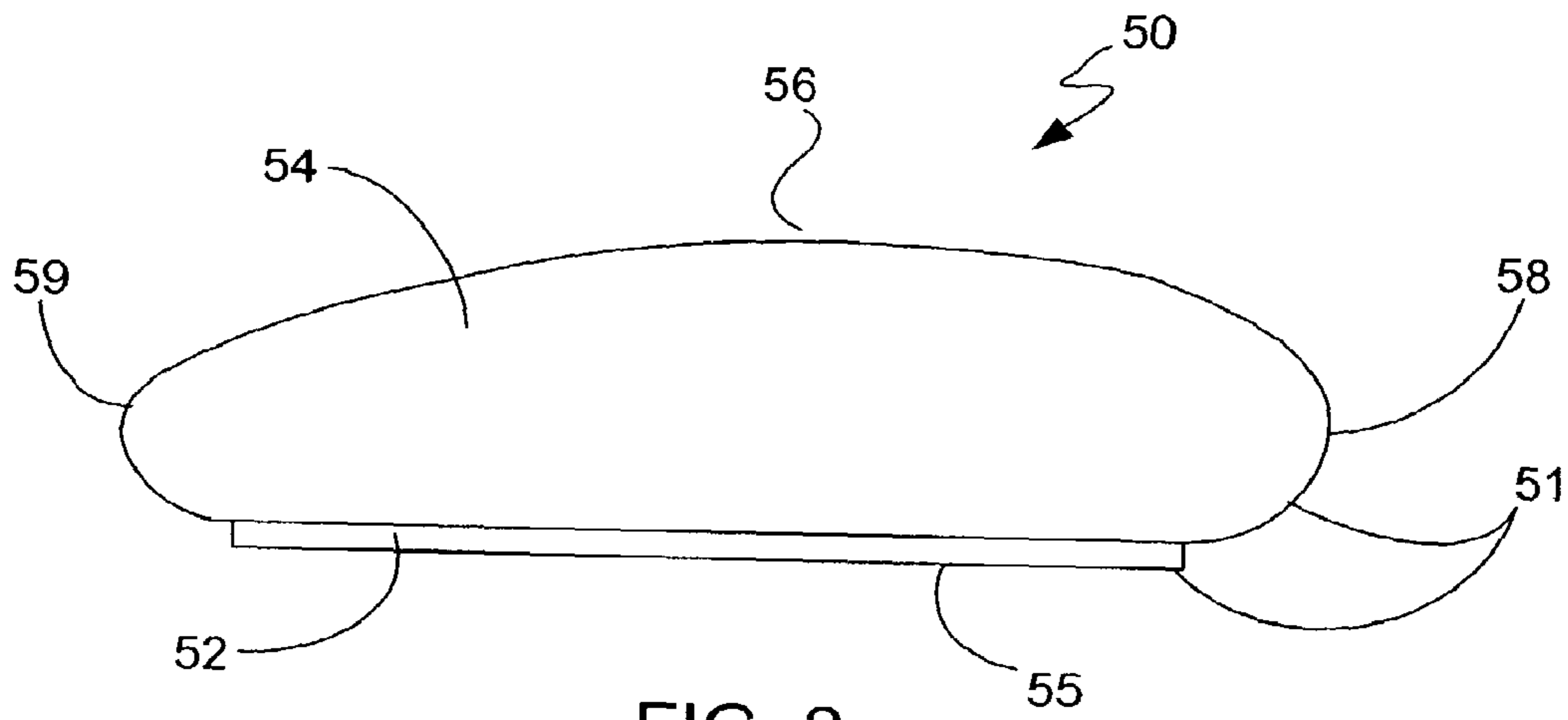

FIG. 2

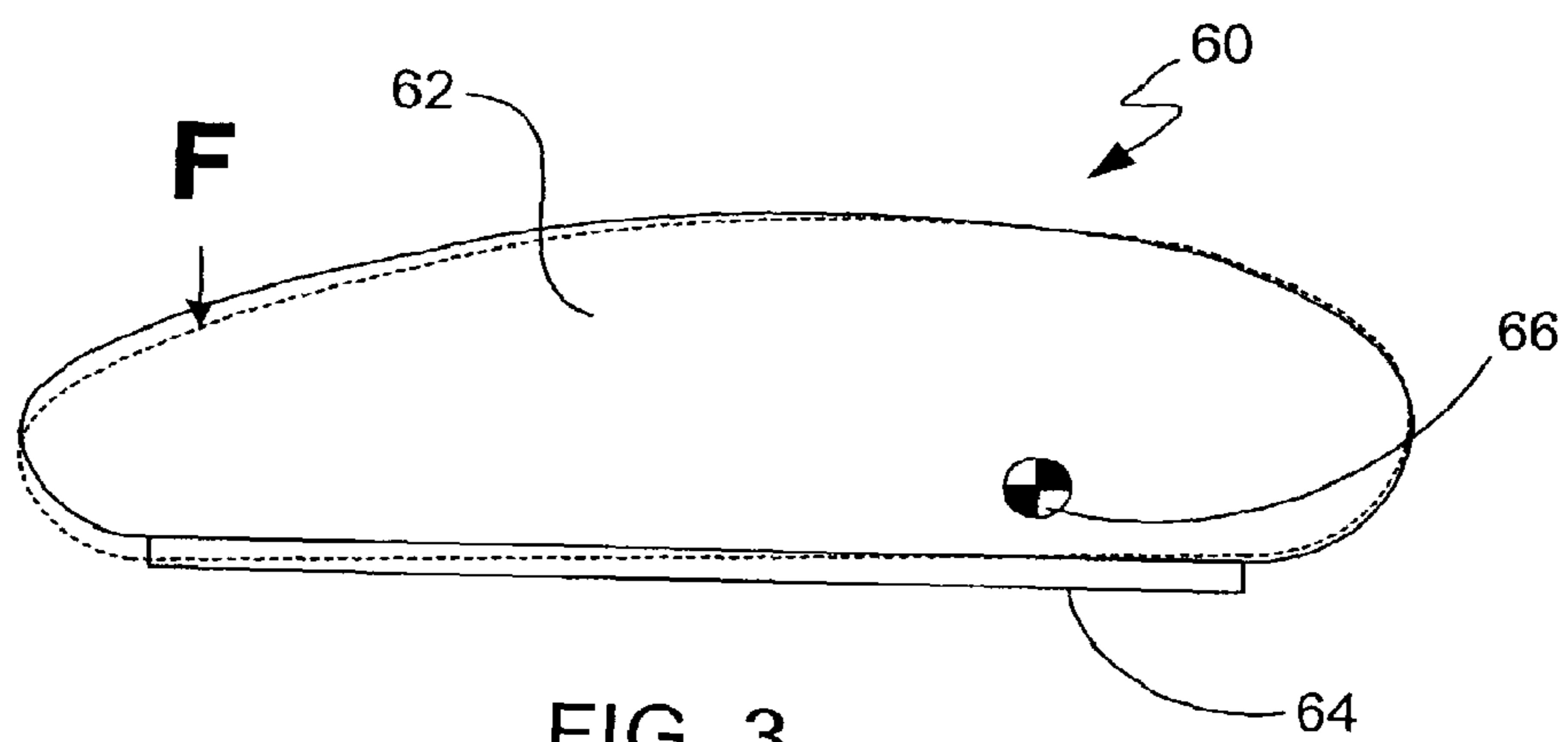

FIG. 3

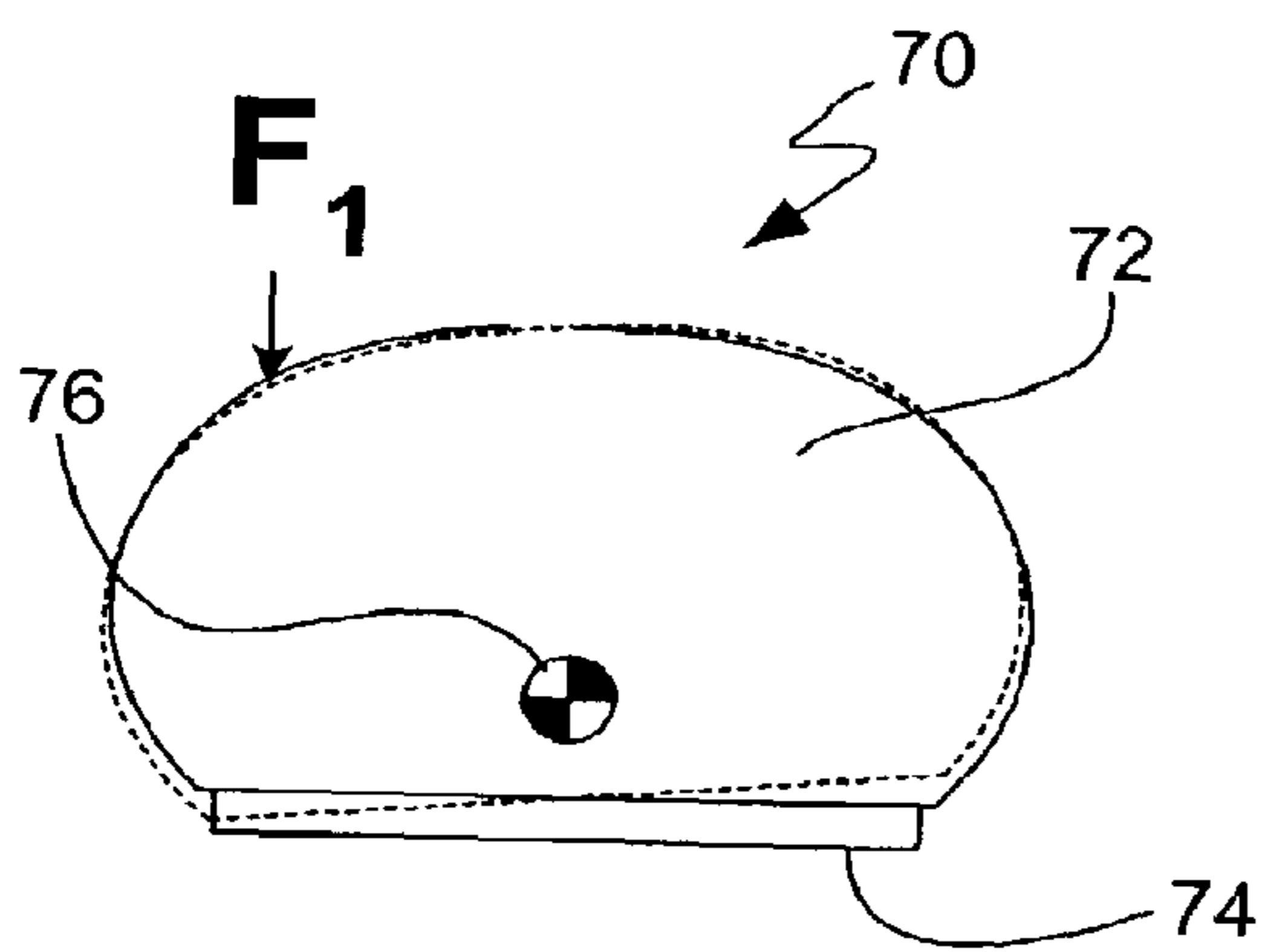

FIG. 4A

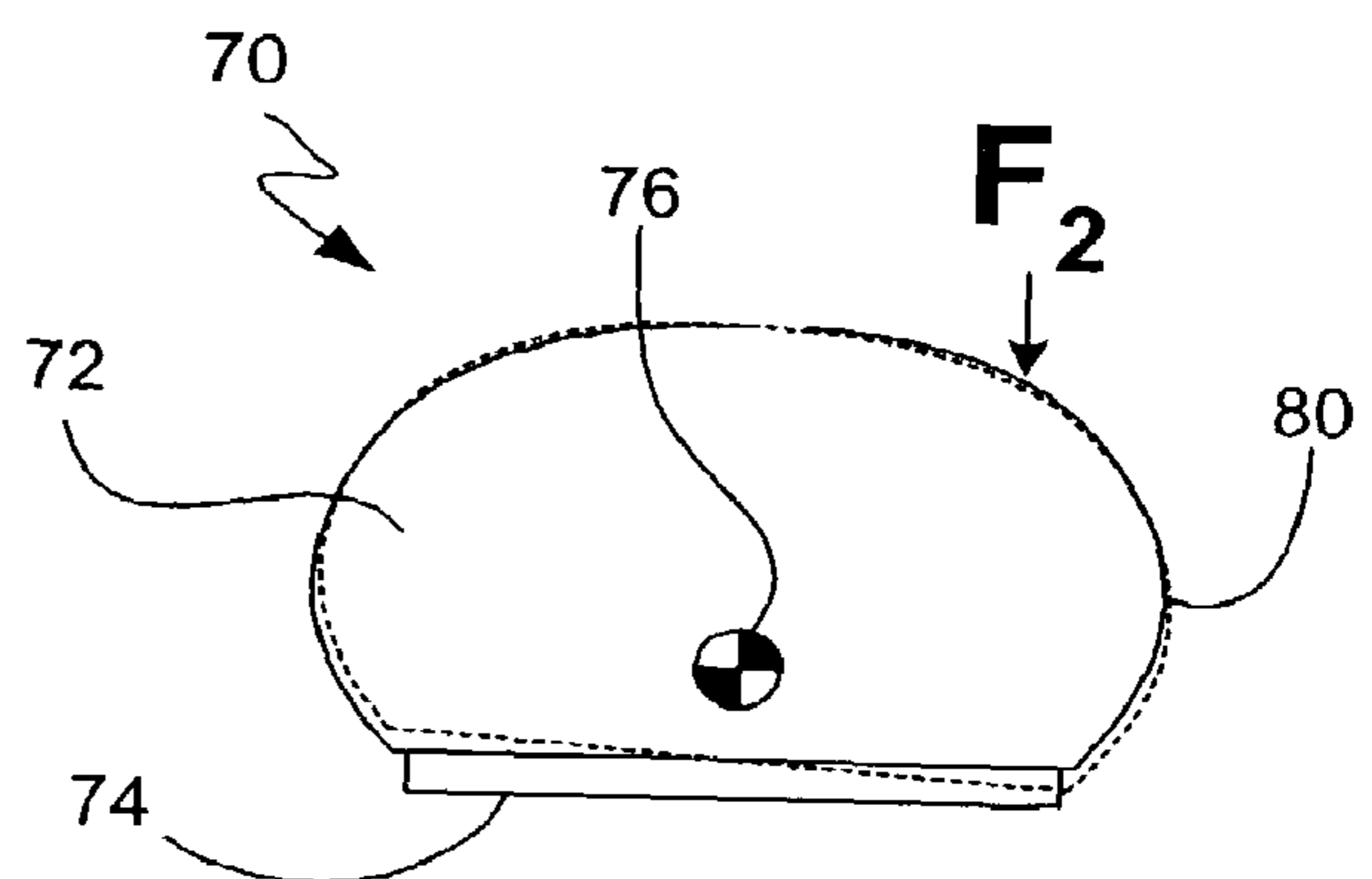

FIG. 4B

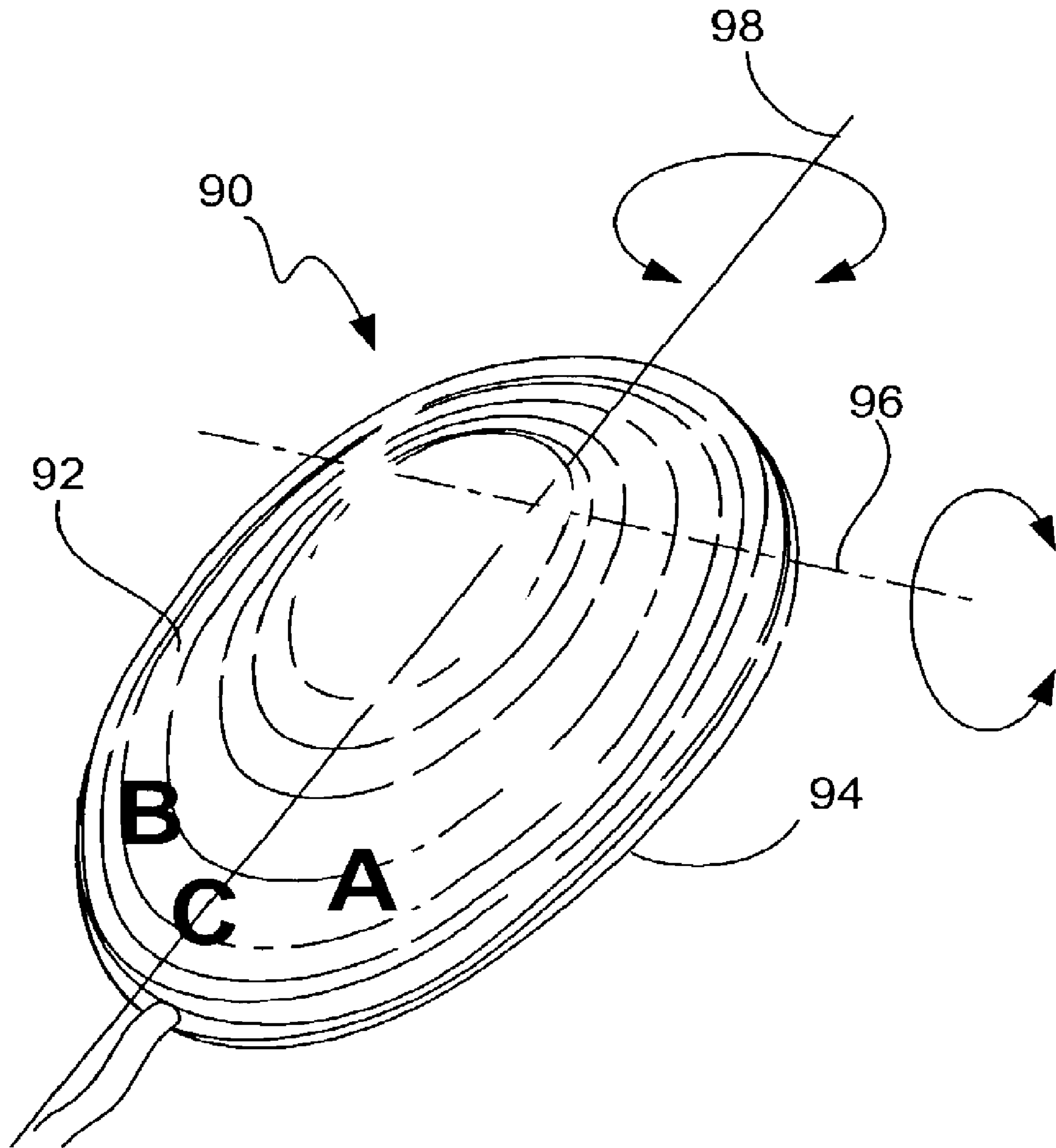

FIG. 5

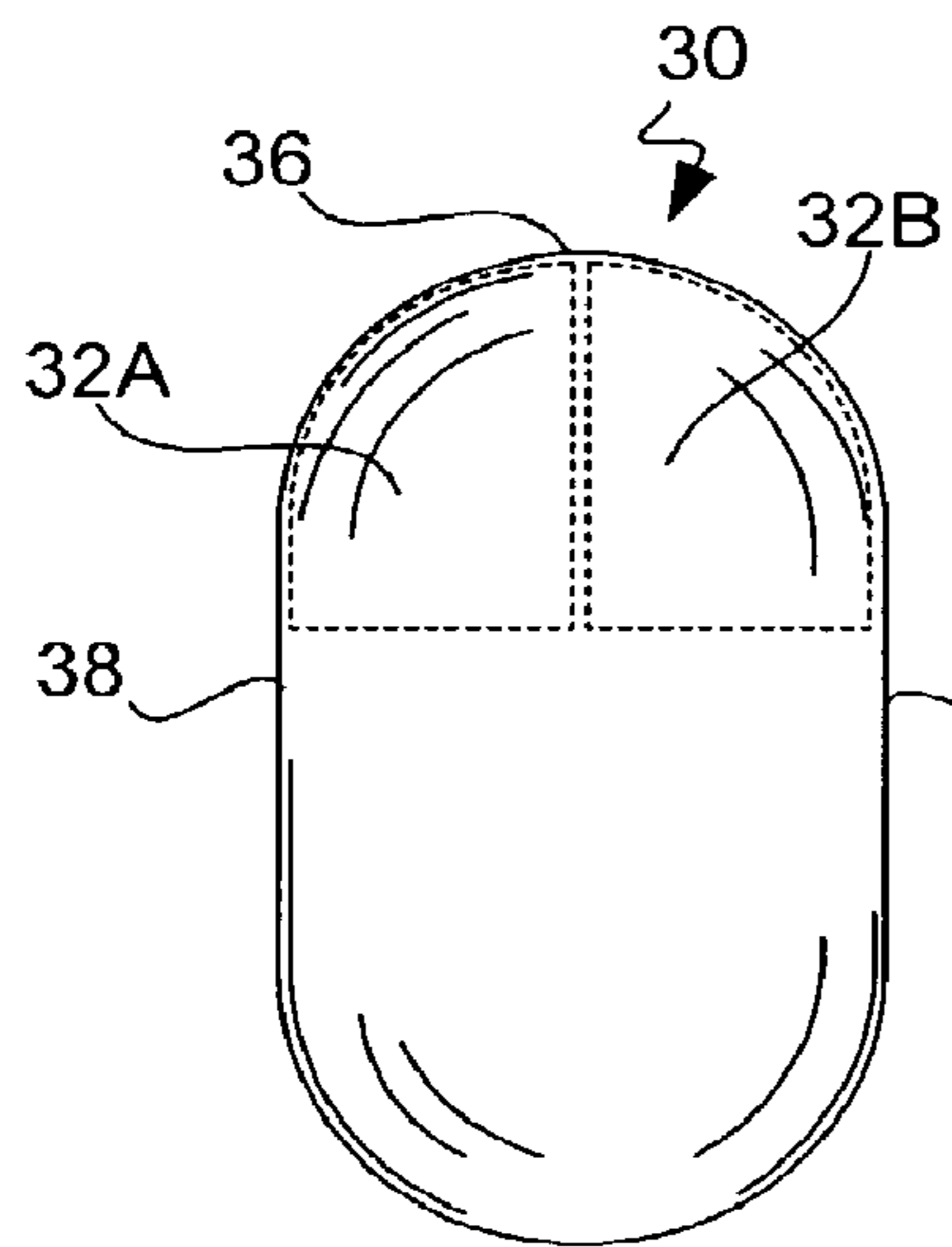

FIG. 6A

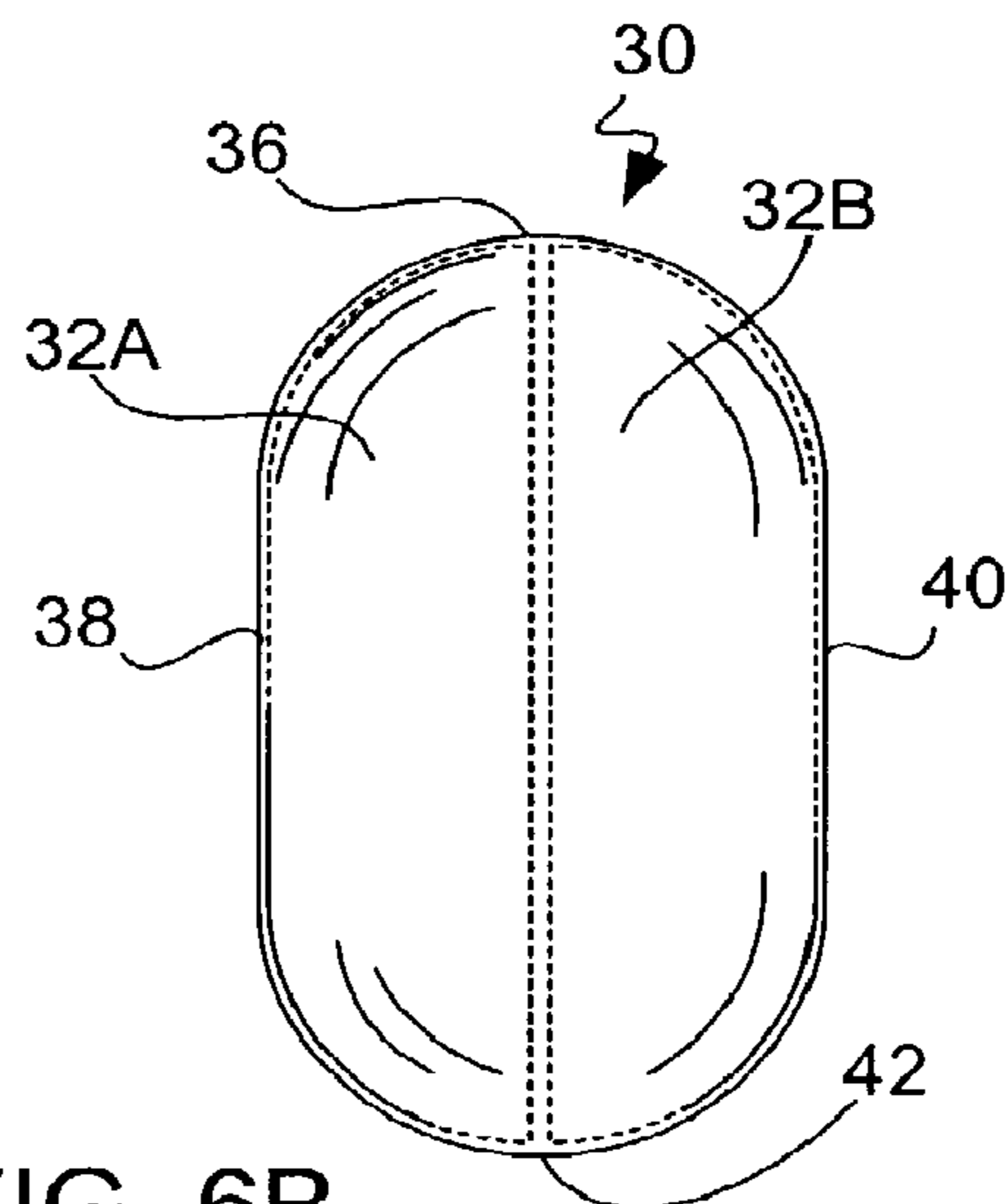

FIG. 6B

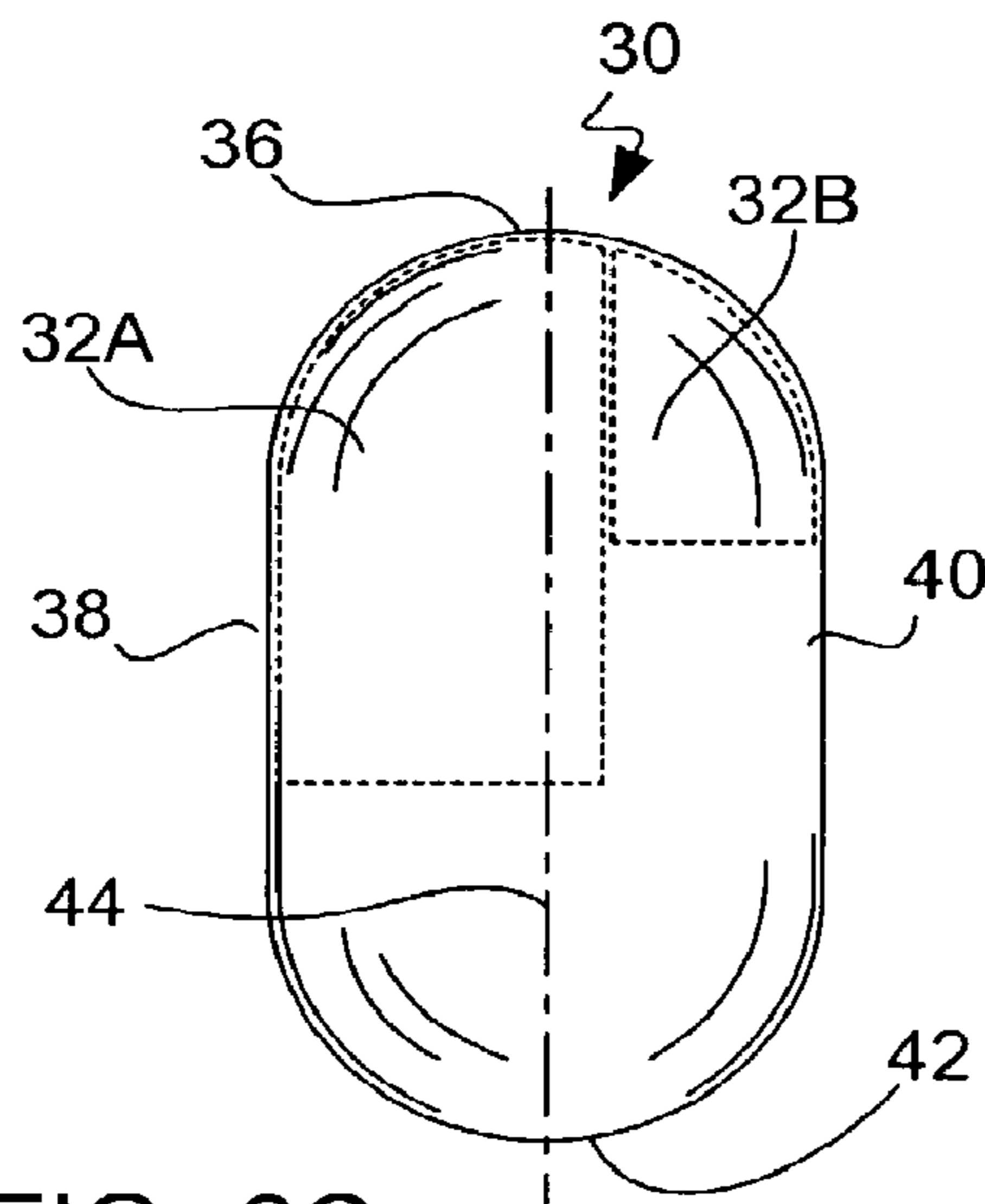

FIG. 6C

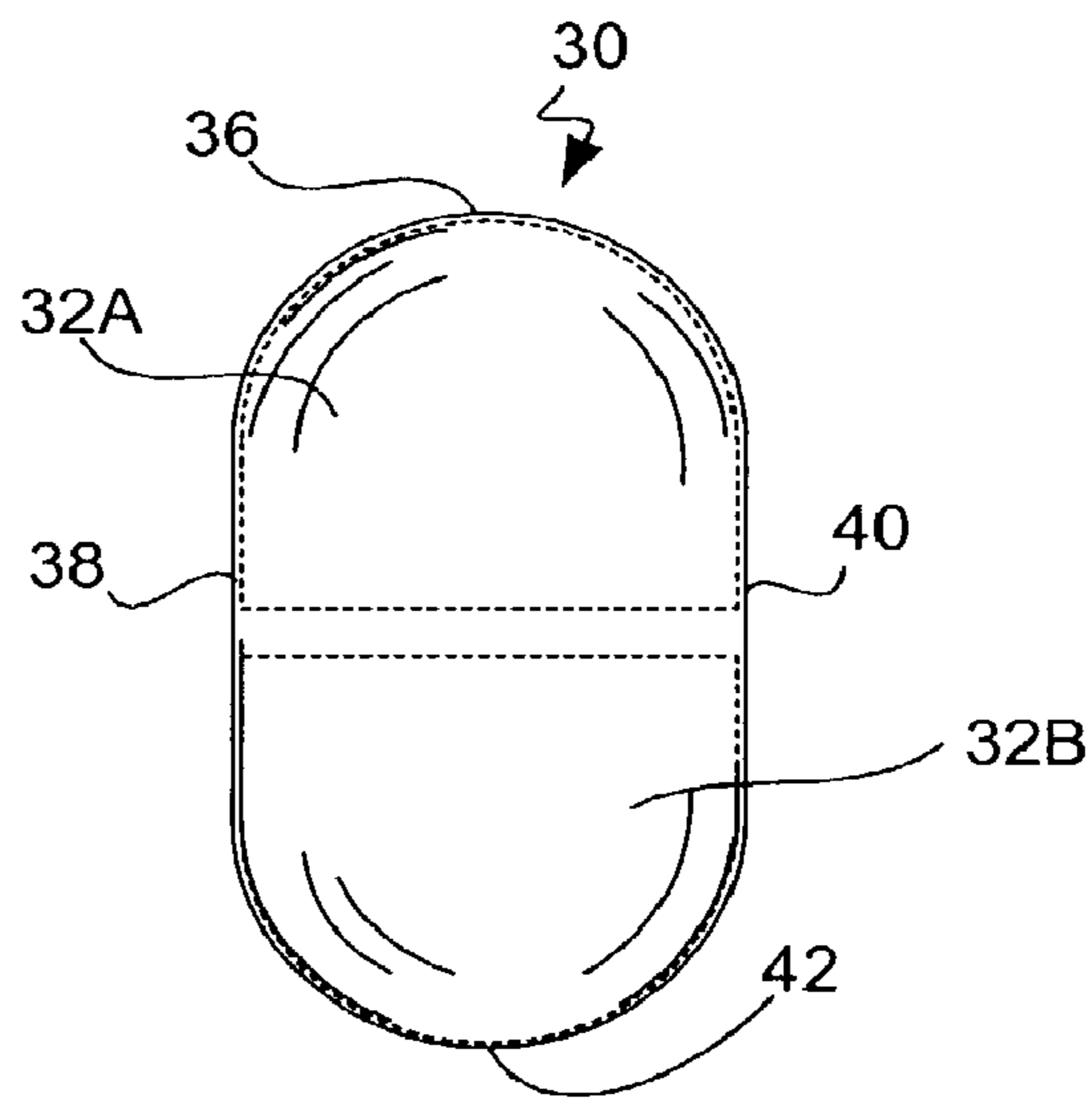

FIG. 6D

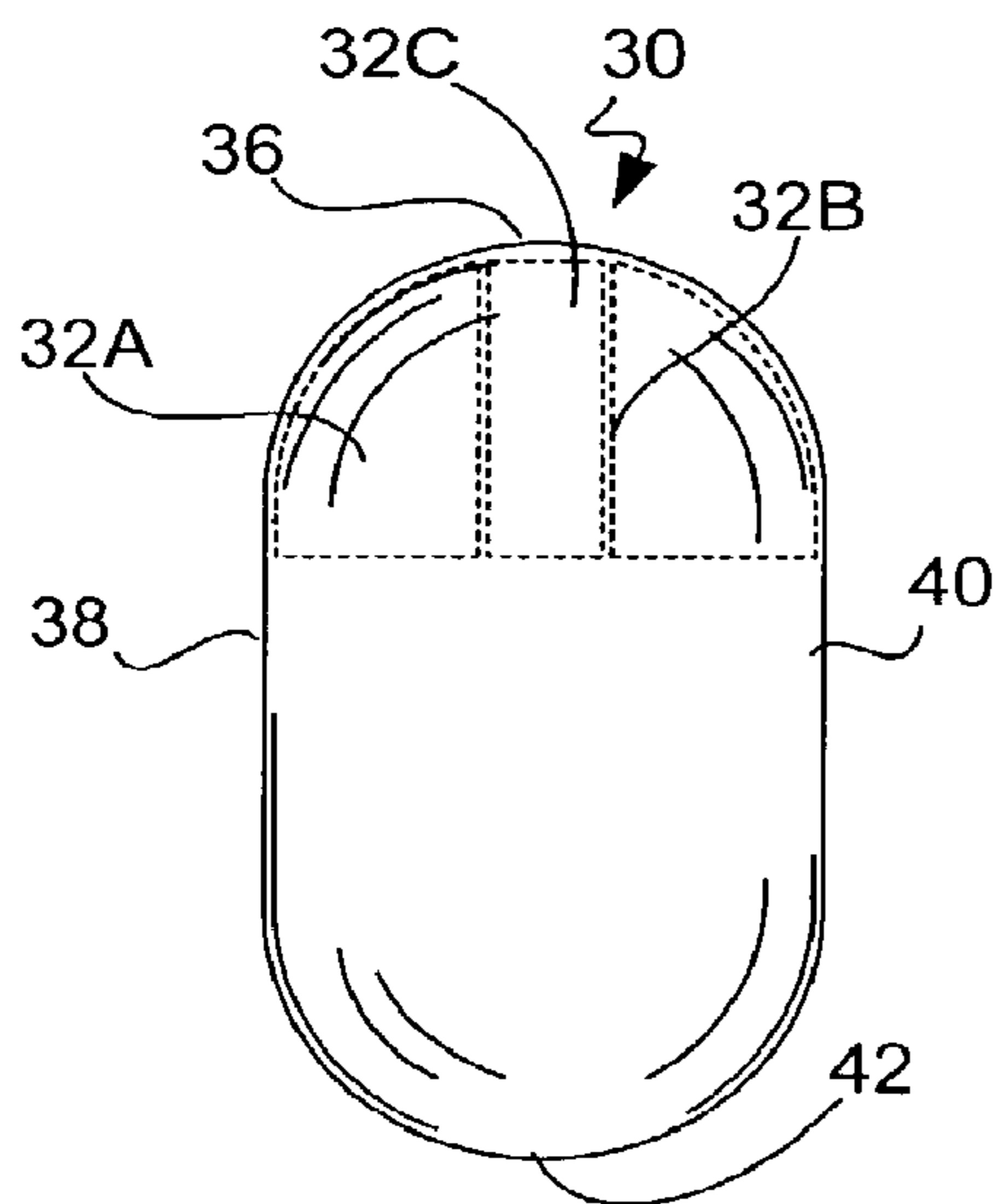

FIG. 6E

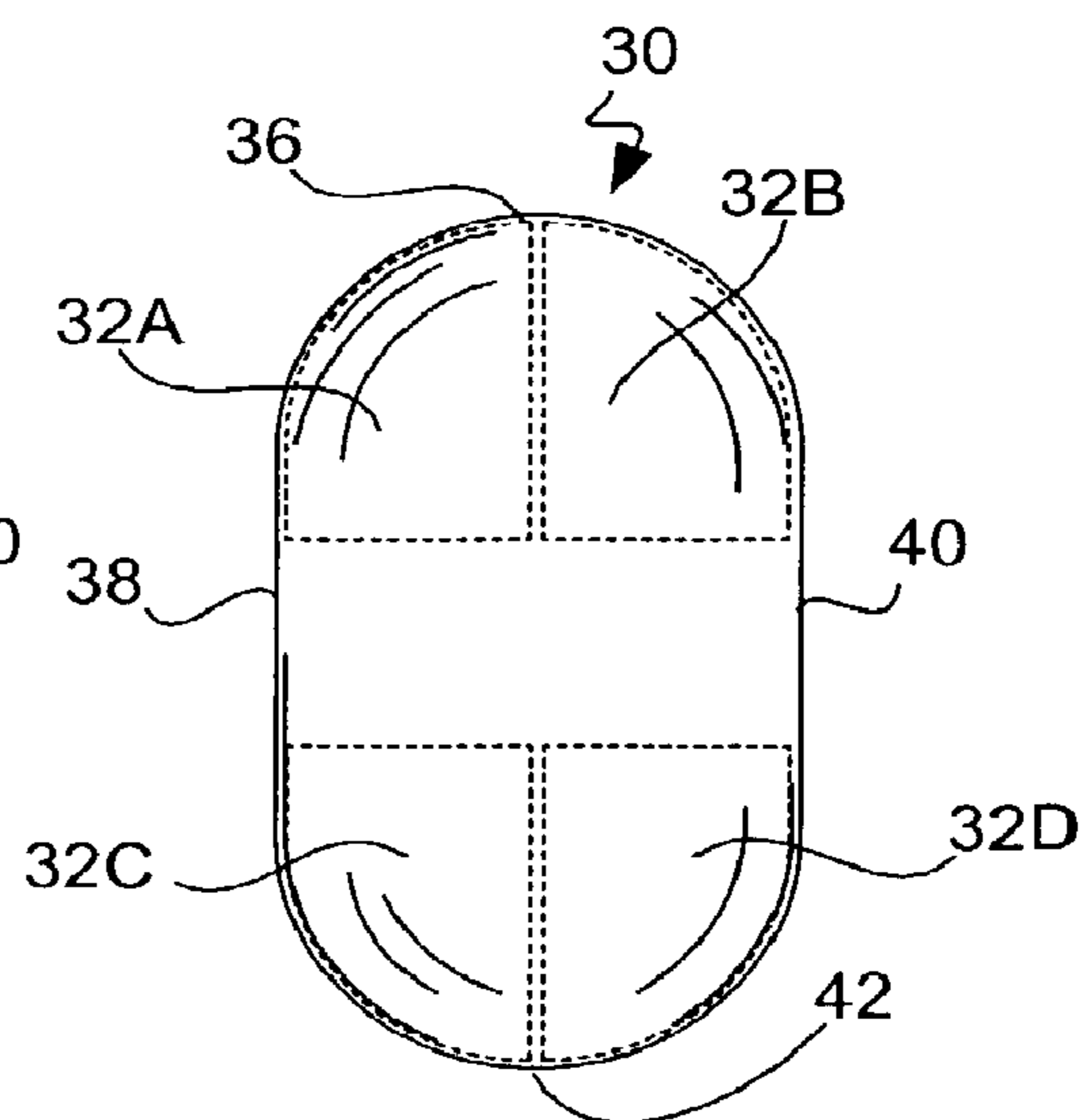

FIG. 6F

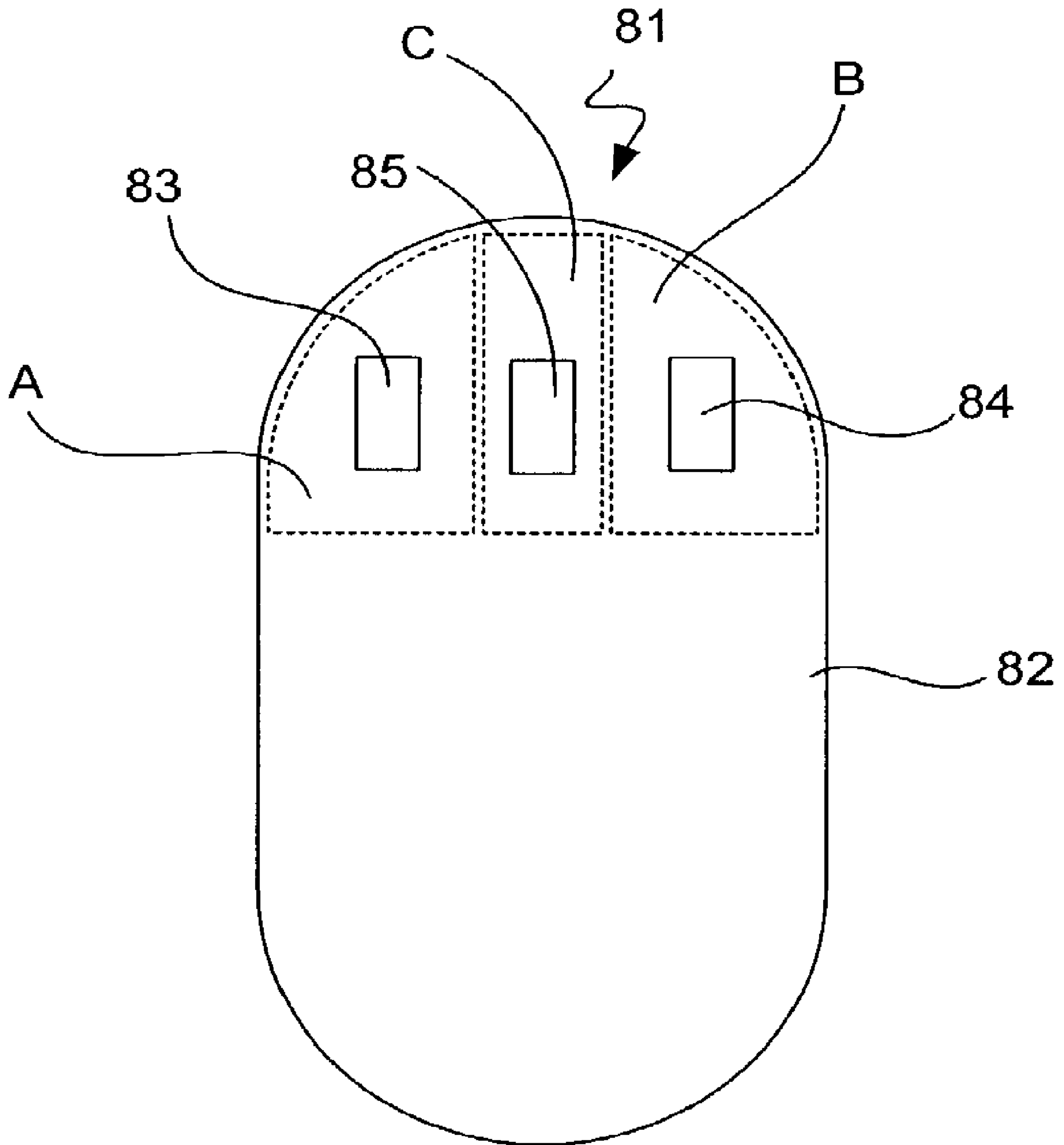

FIG. 7

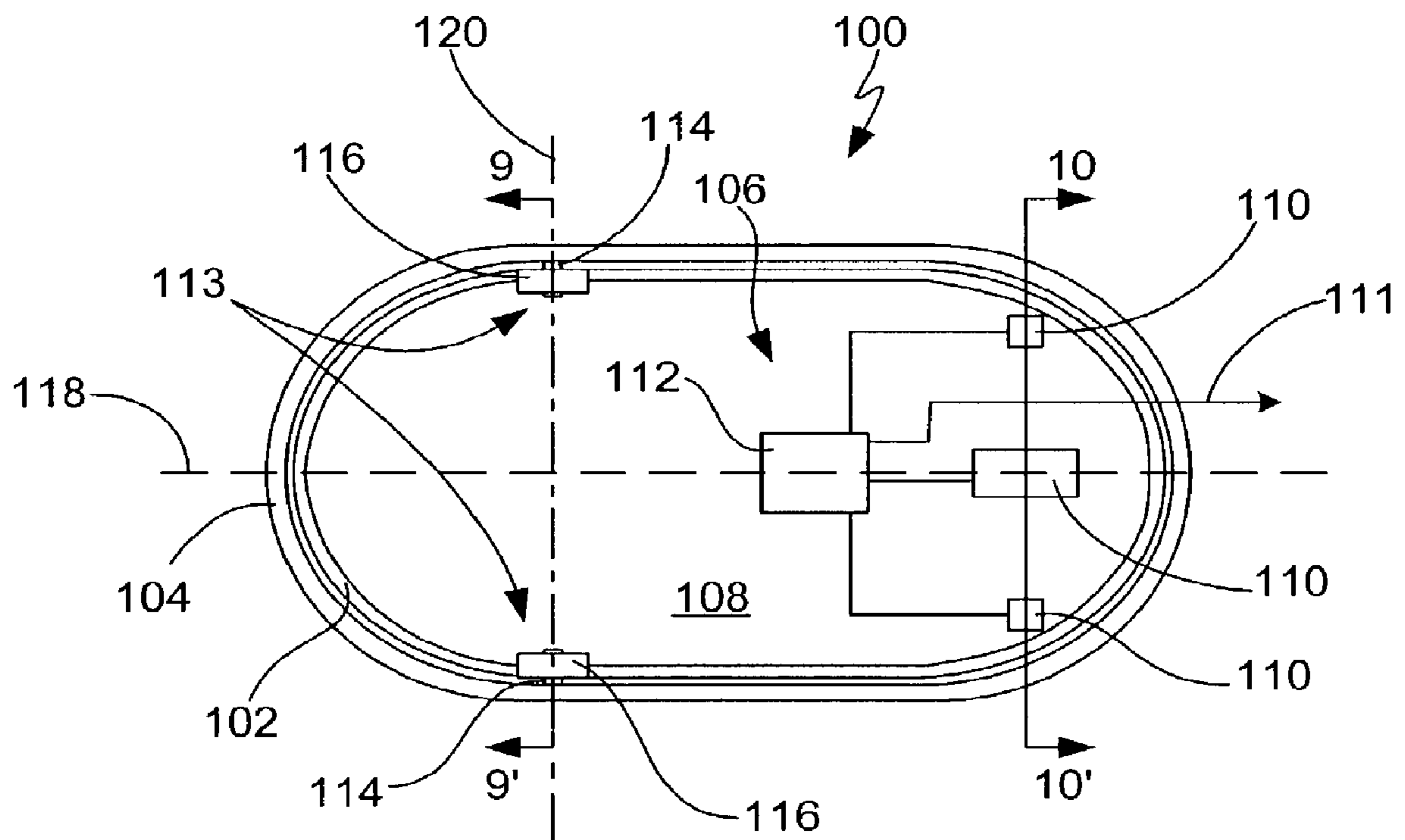

FIG. 8

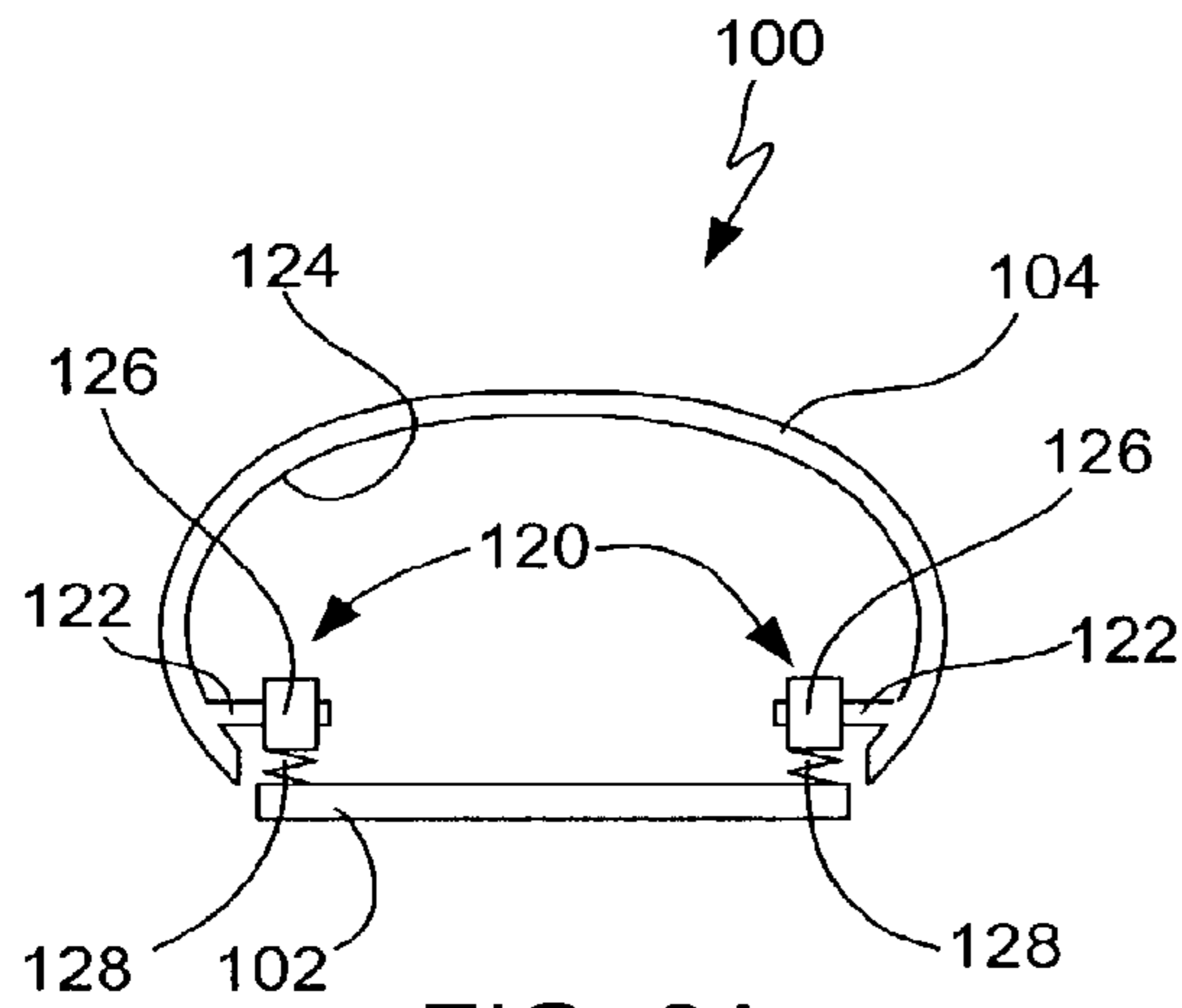

FIG. 9A

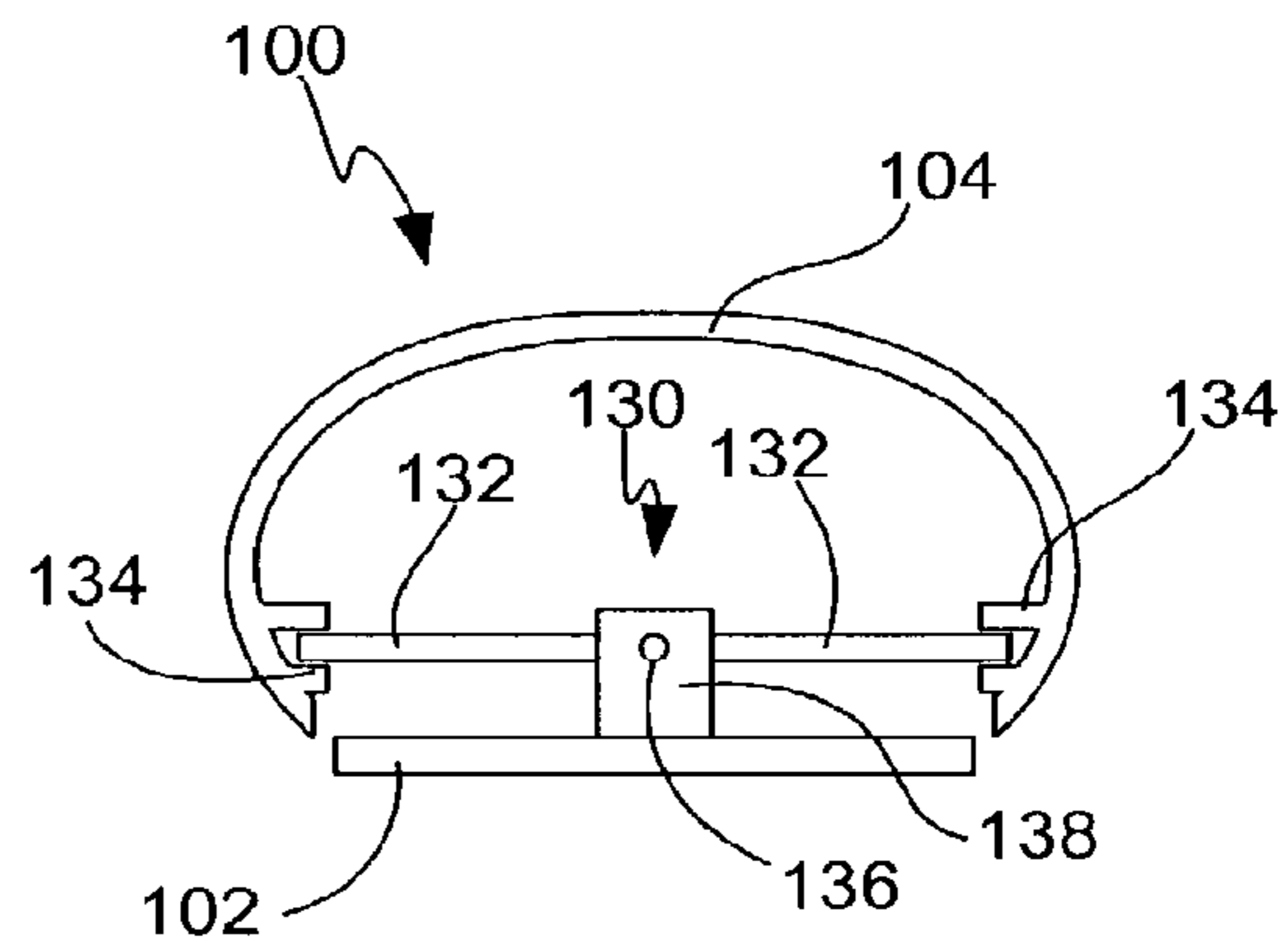

FIG. 9B

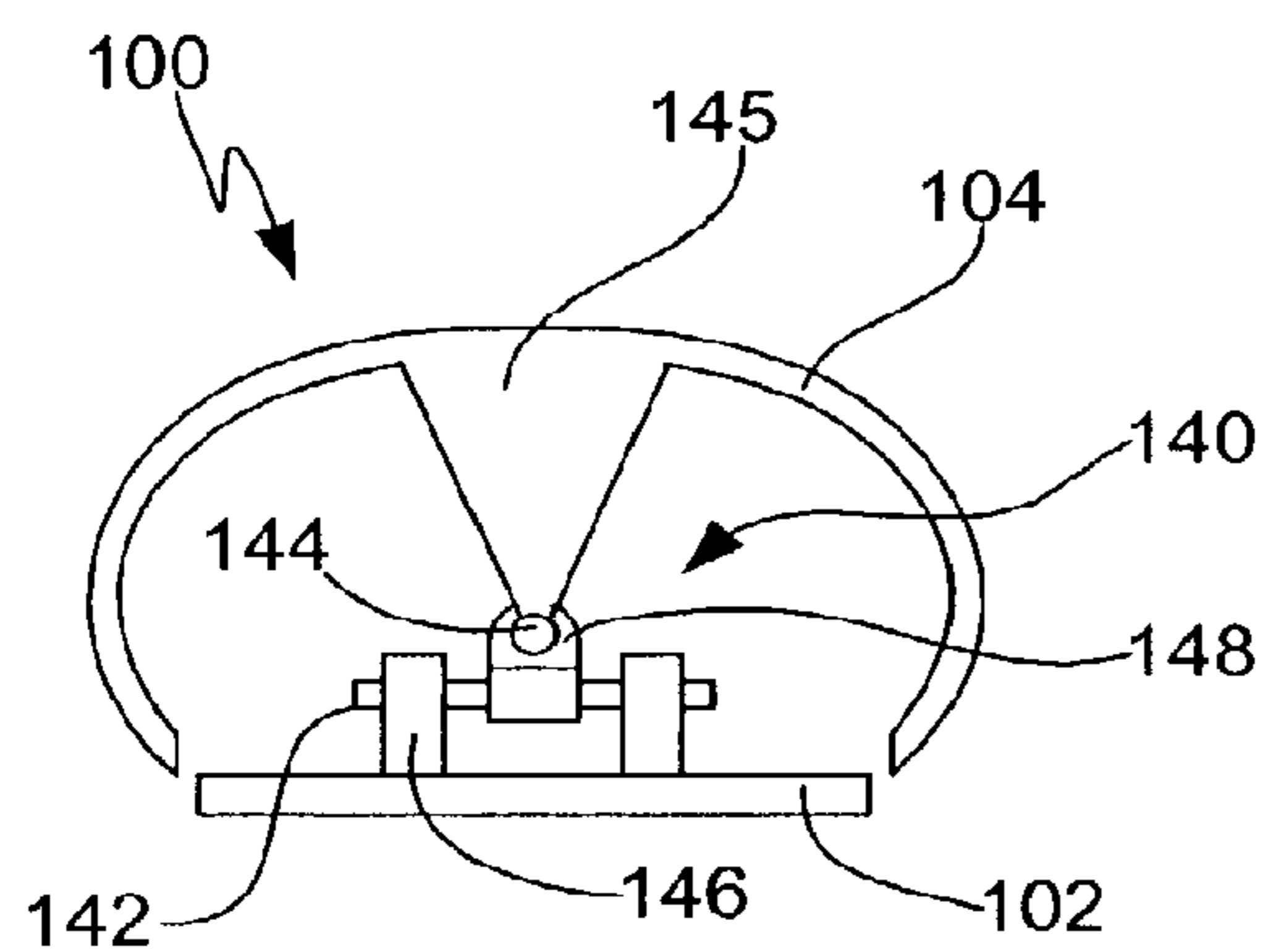

FIG. 9C

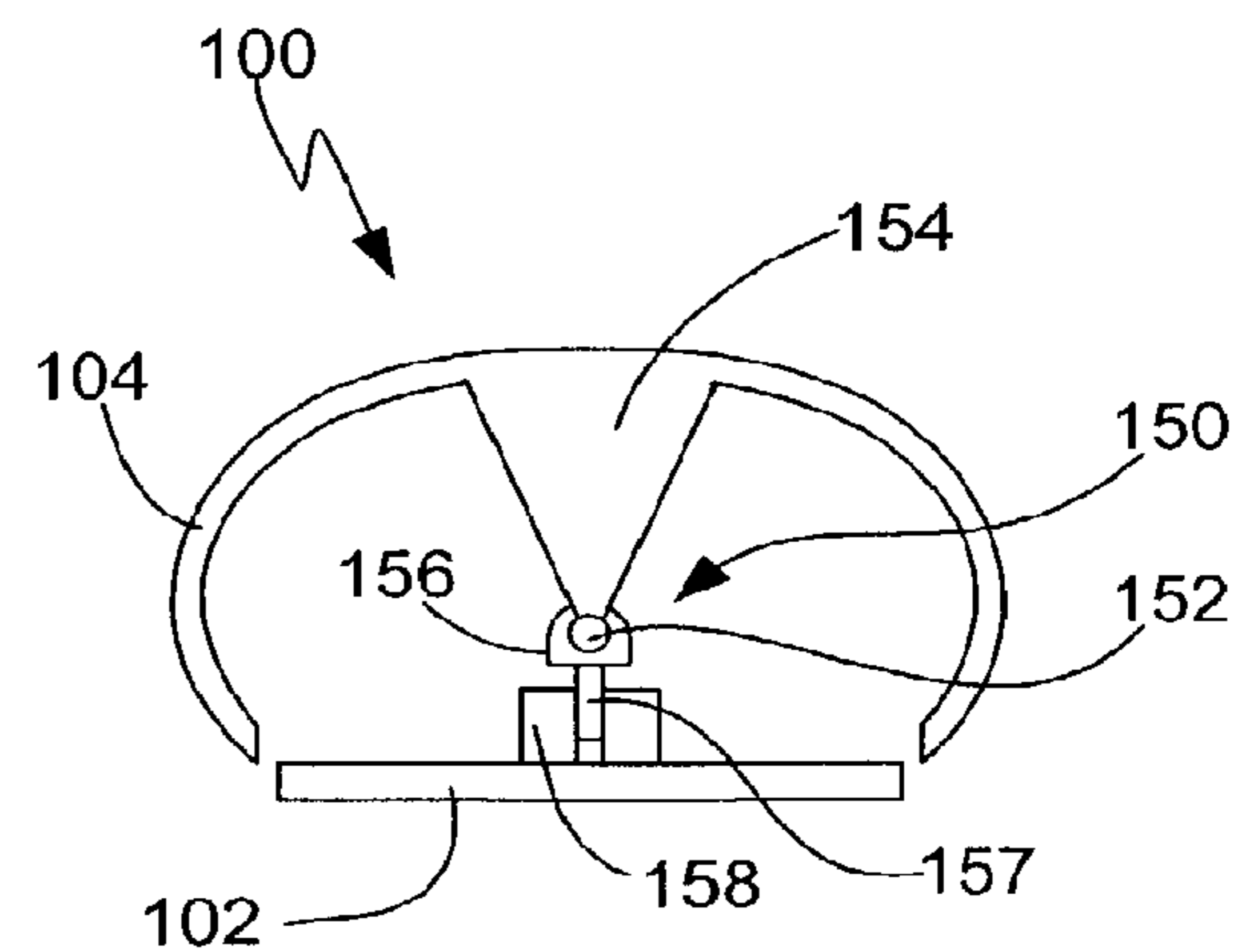

FIG. 9D

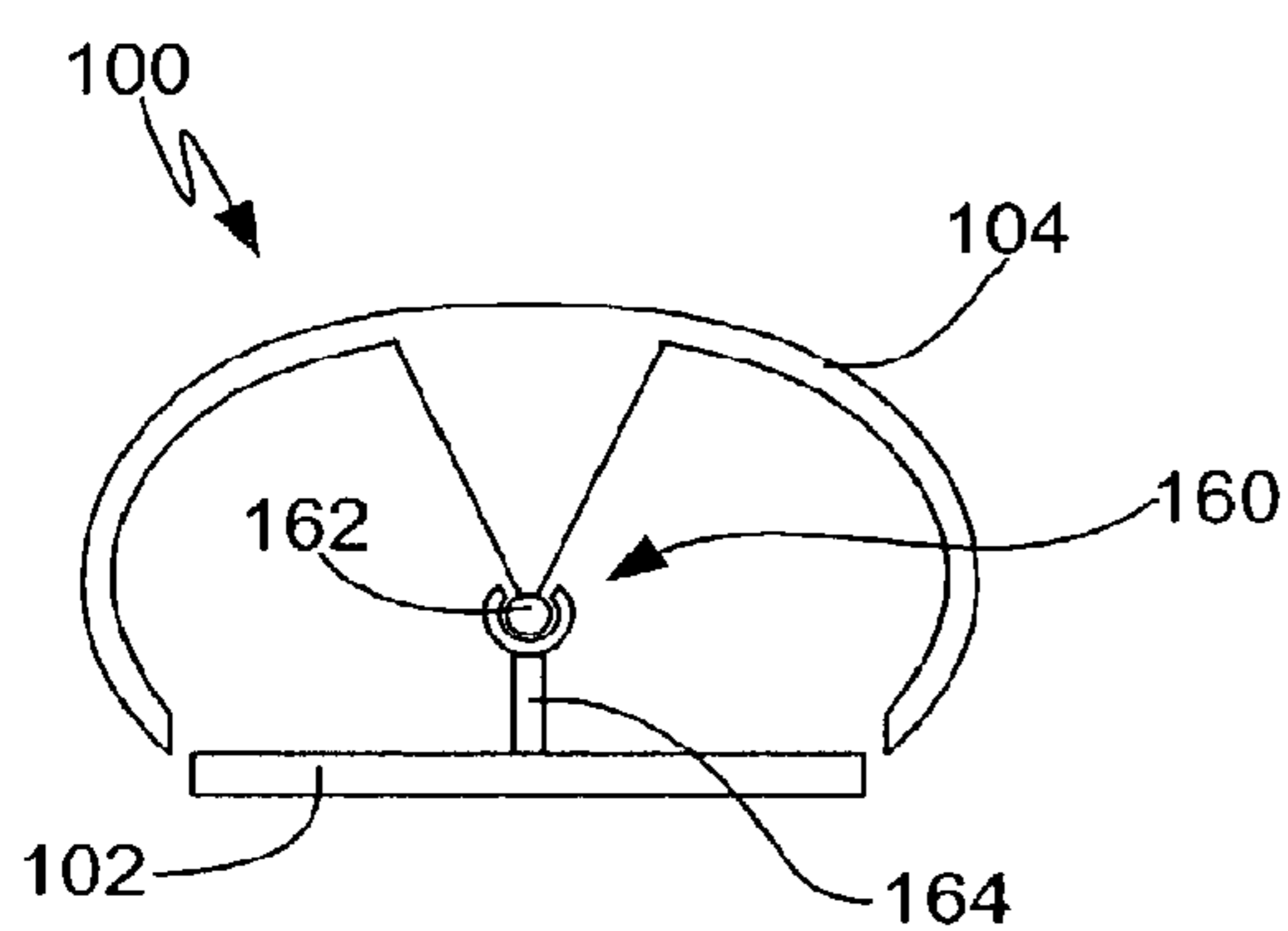

FIG. 9E

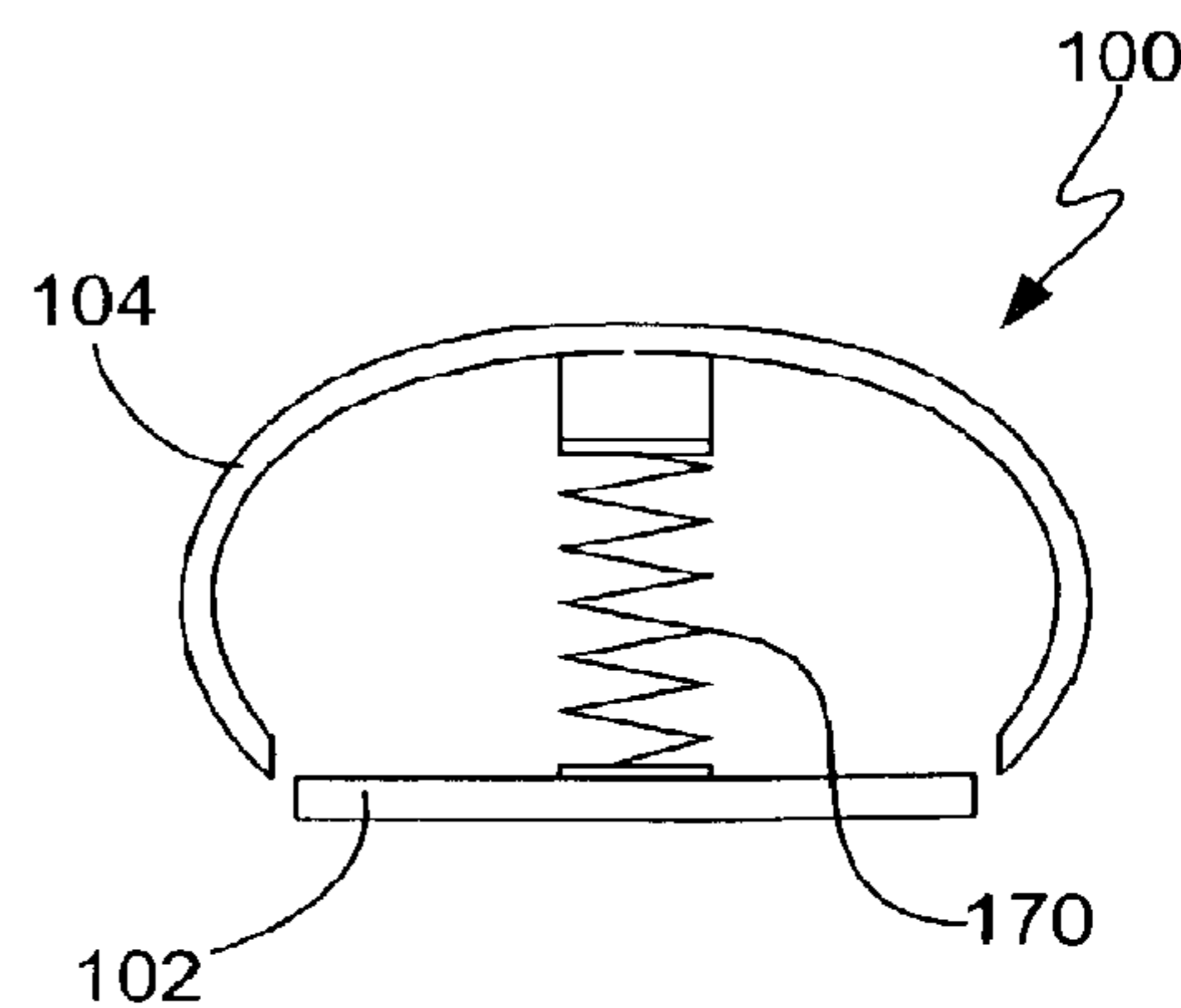

FIG. 9F

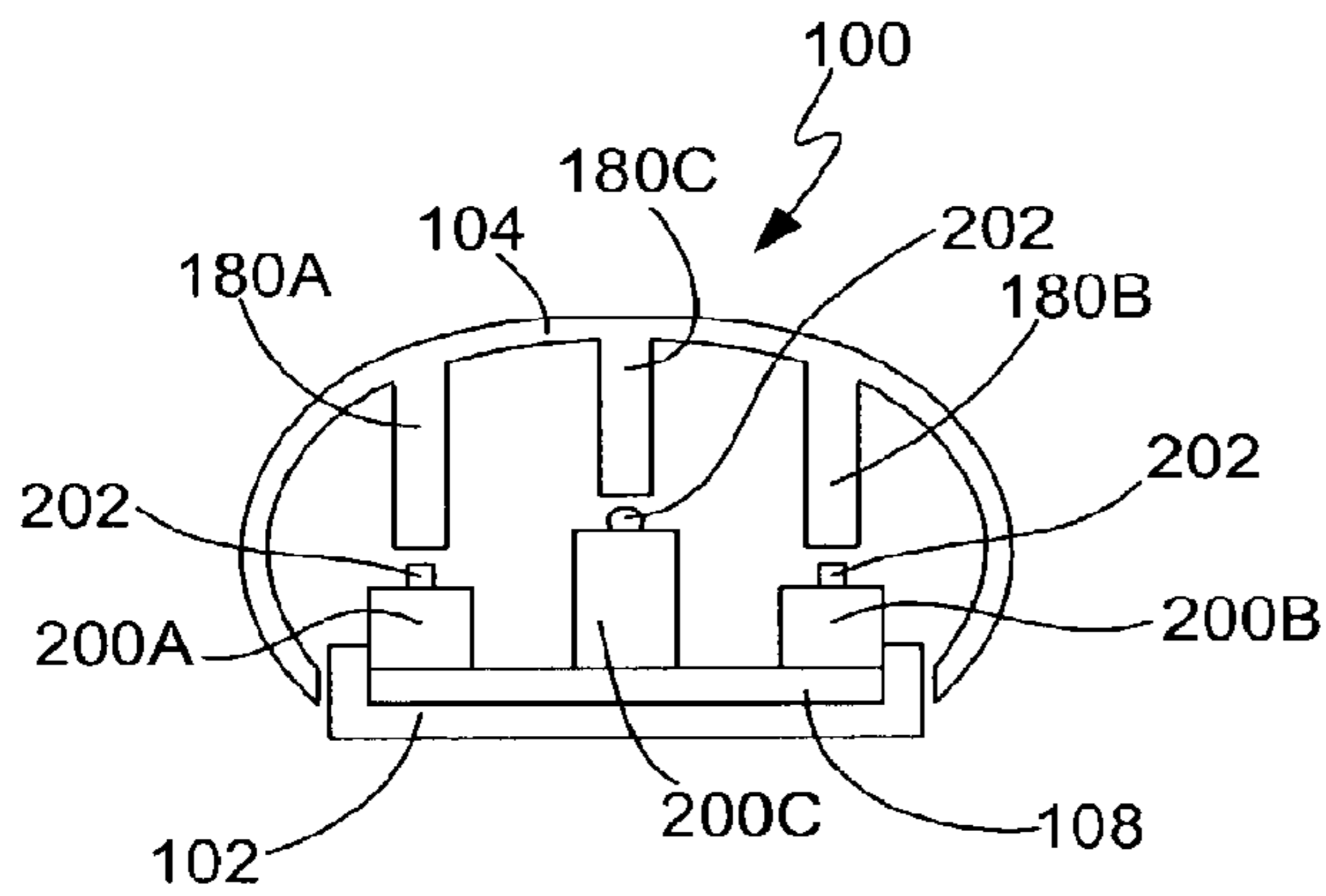

FIG. 10A

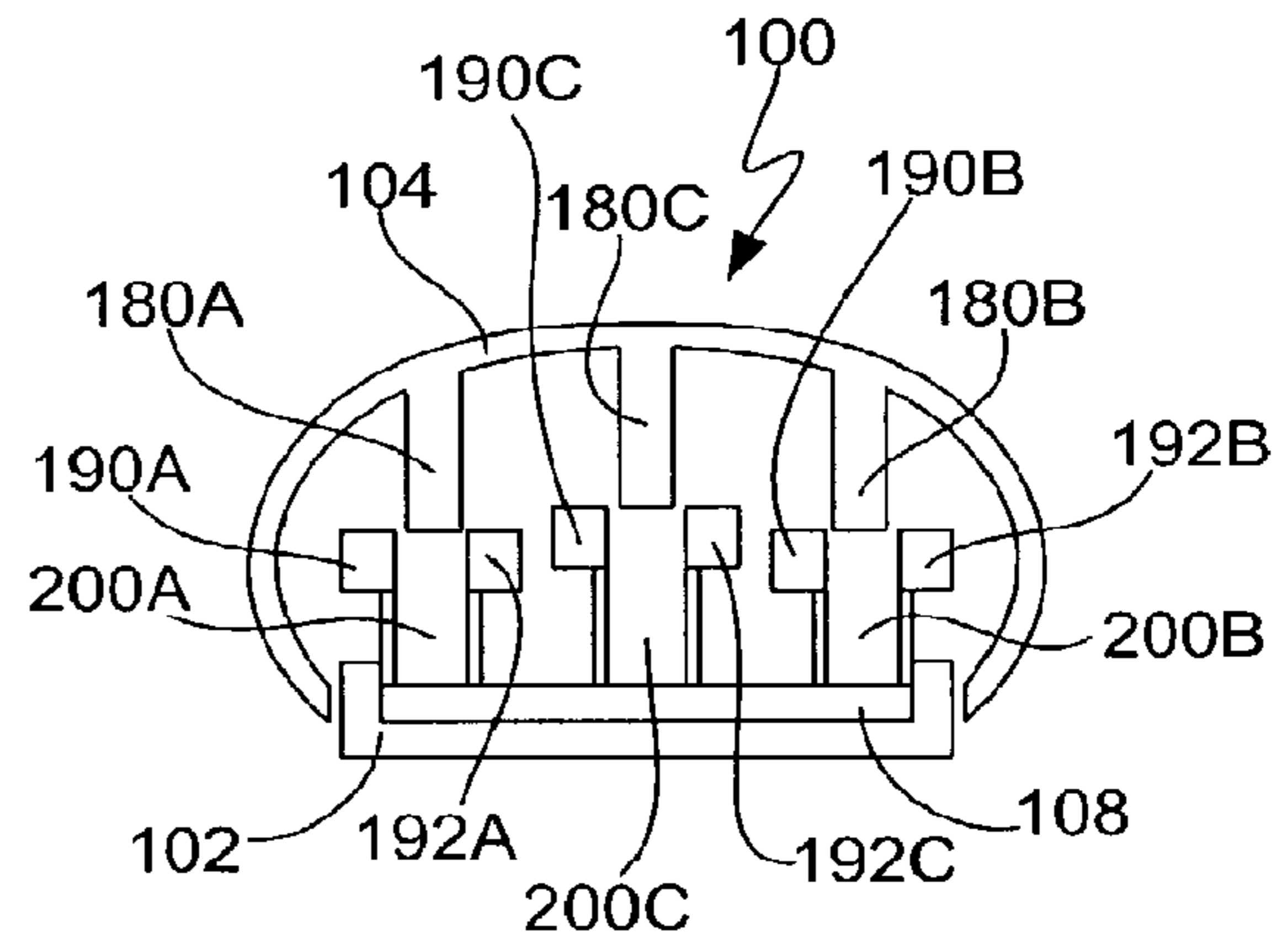

FIG. 10B

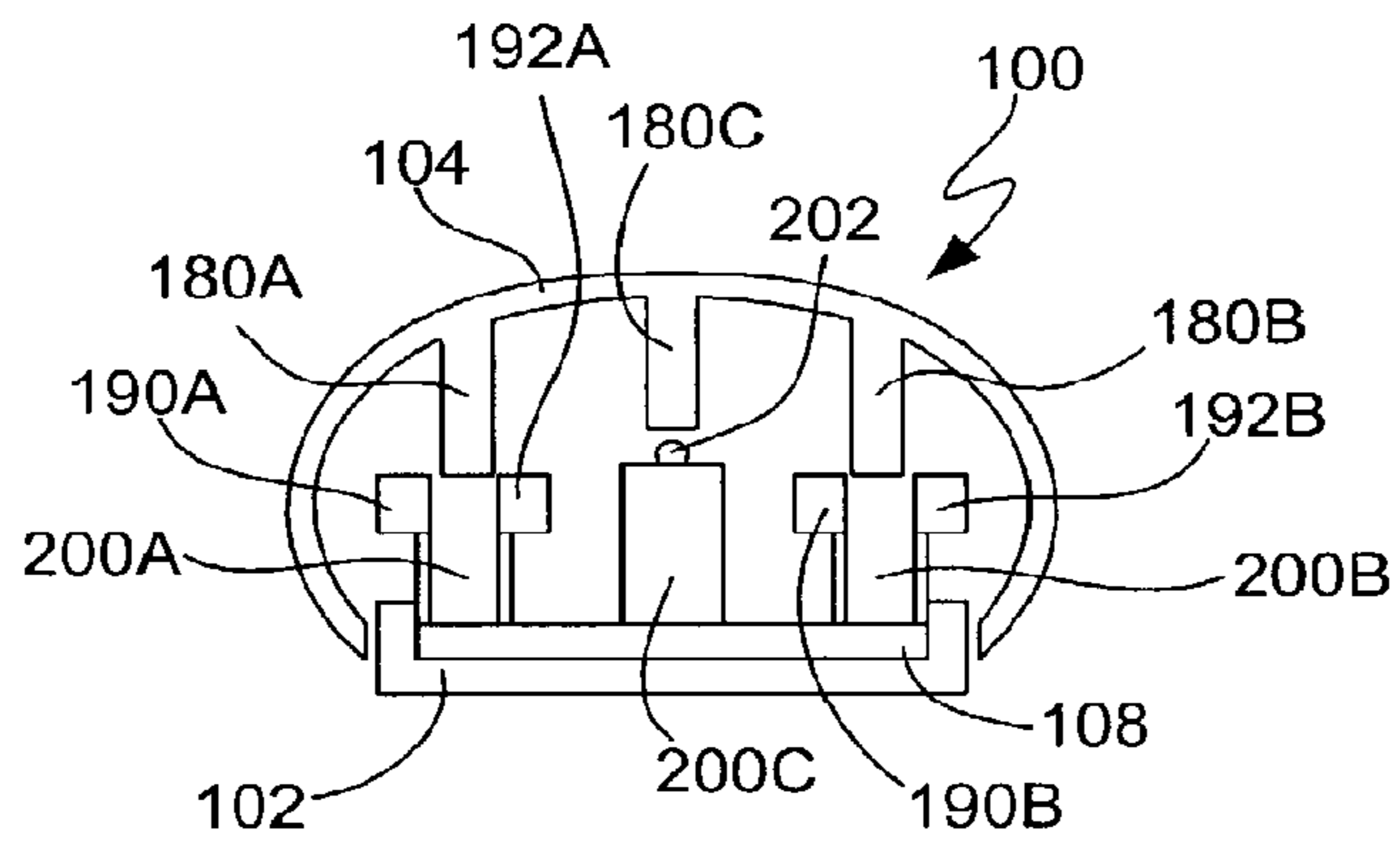

FIG. 10C

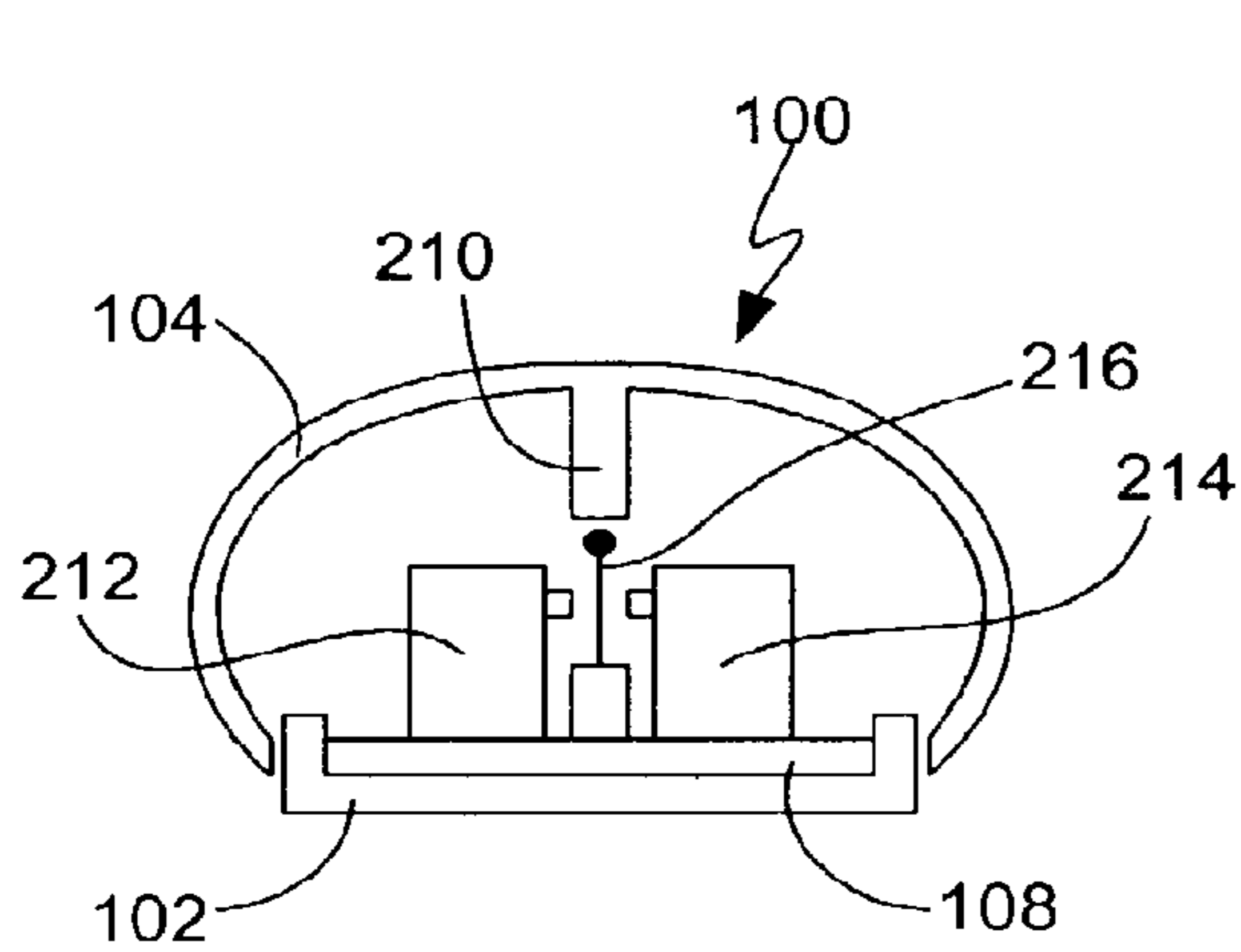

FIG. 11A

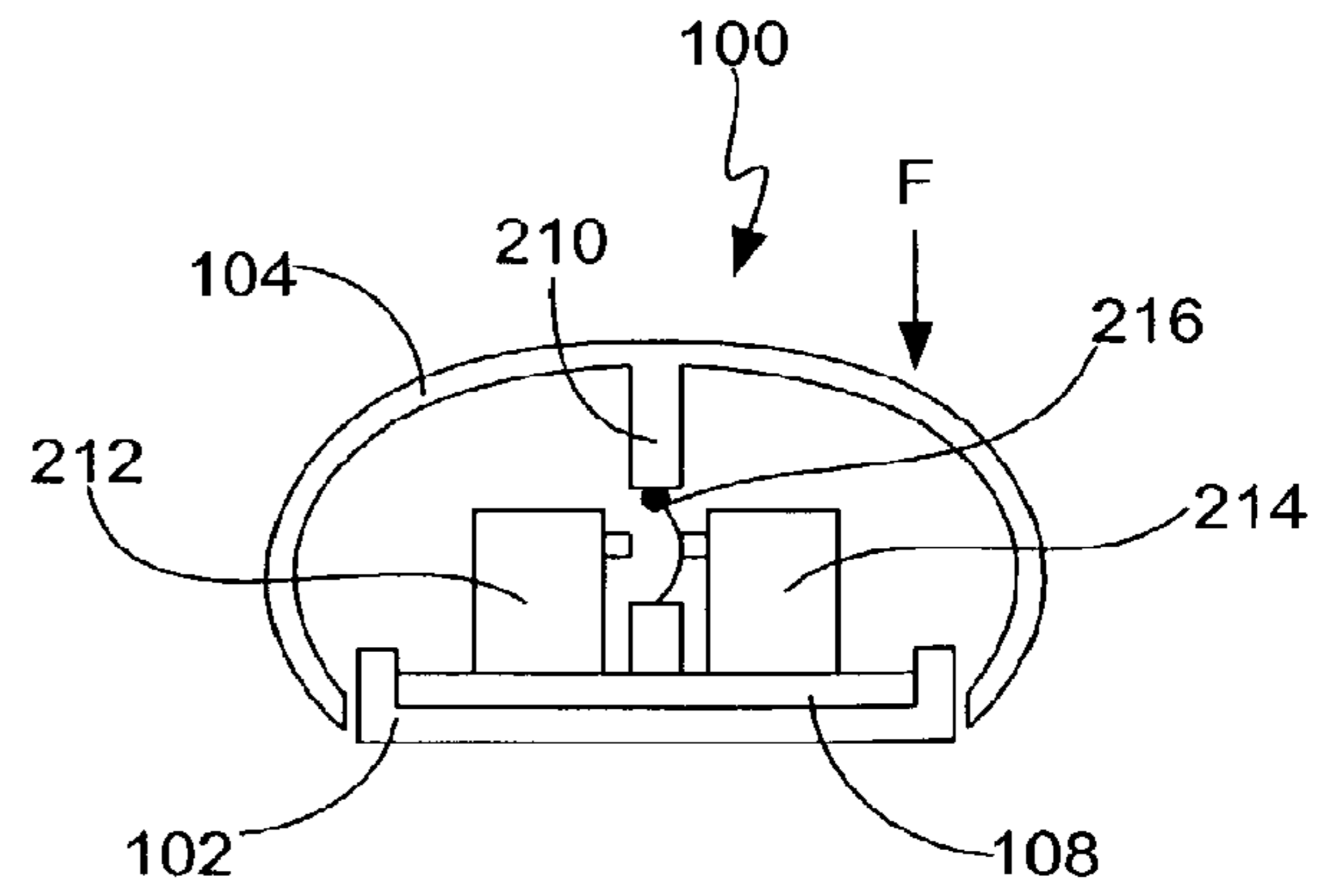

FIG. 11B

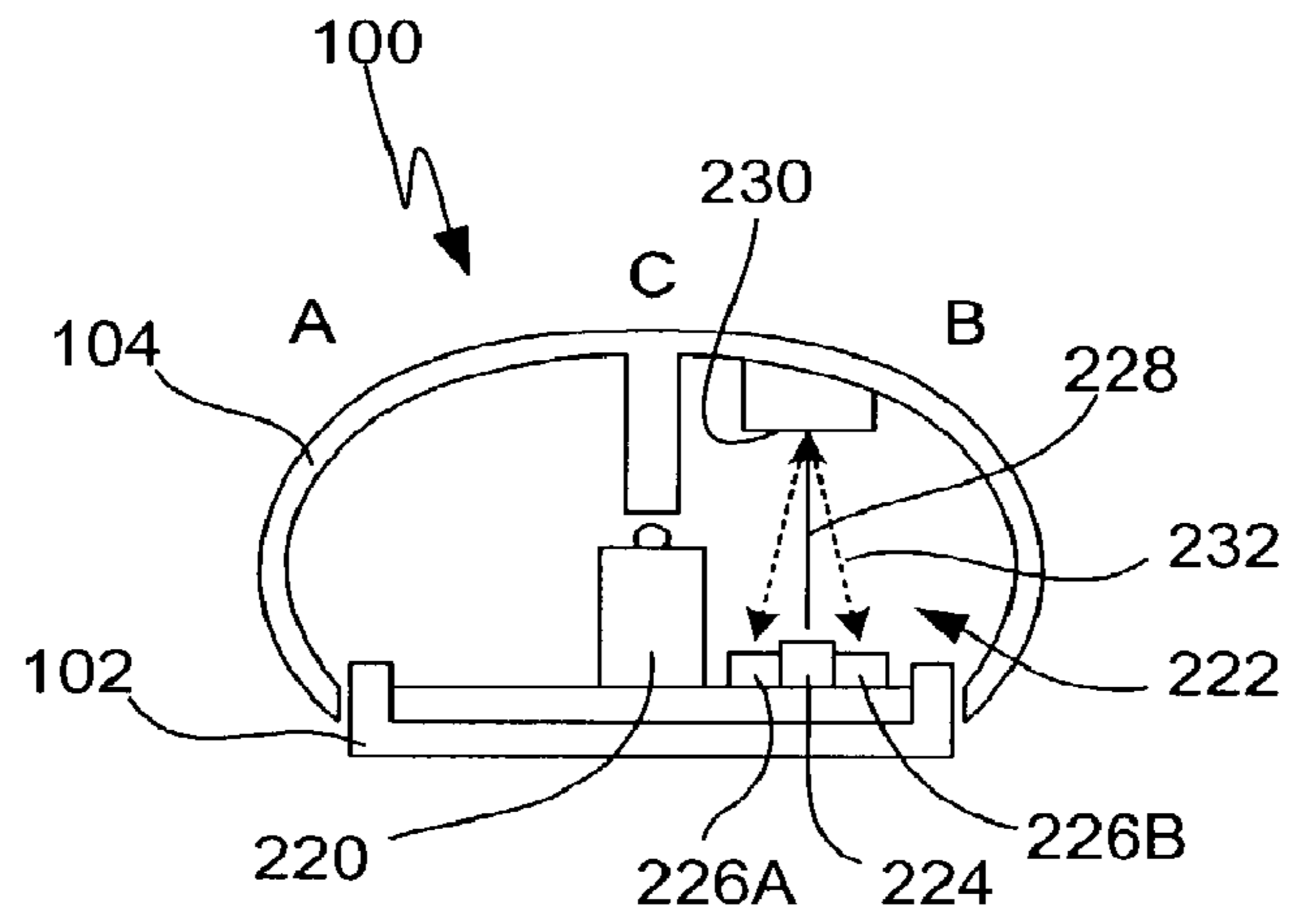

FIG. 12

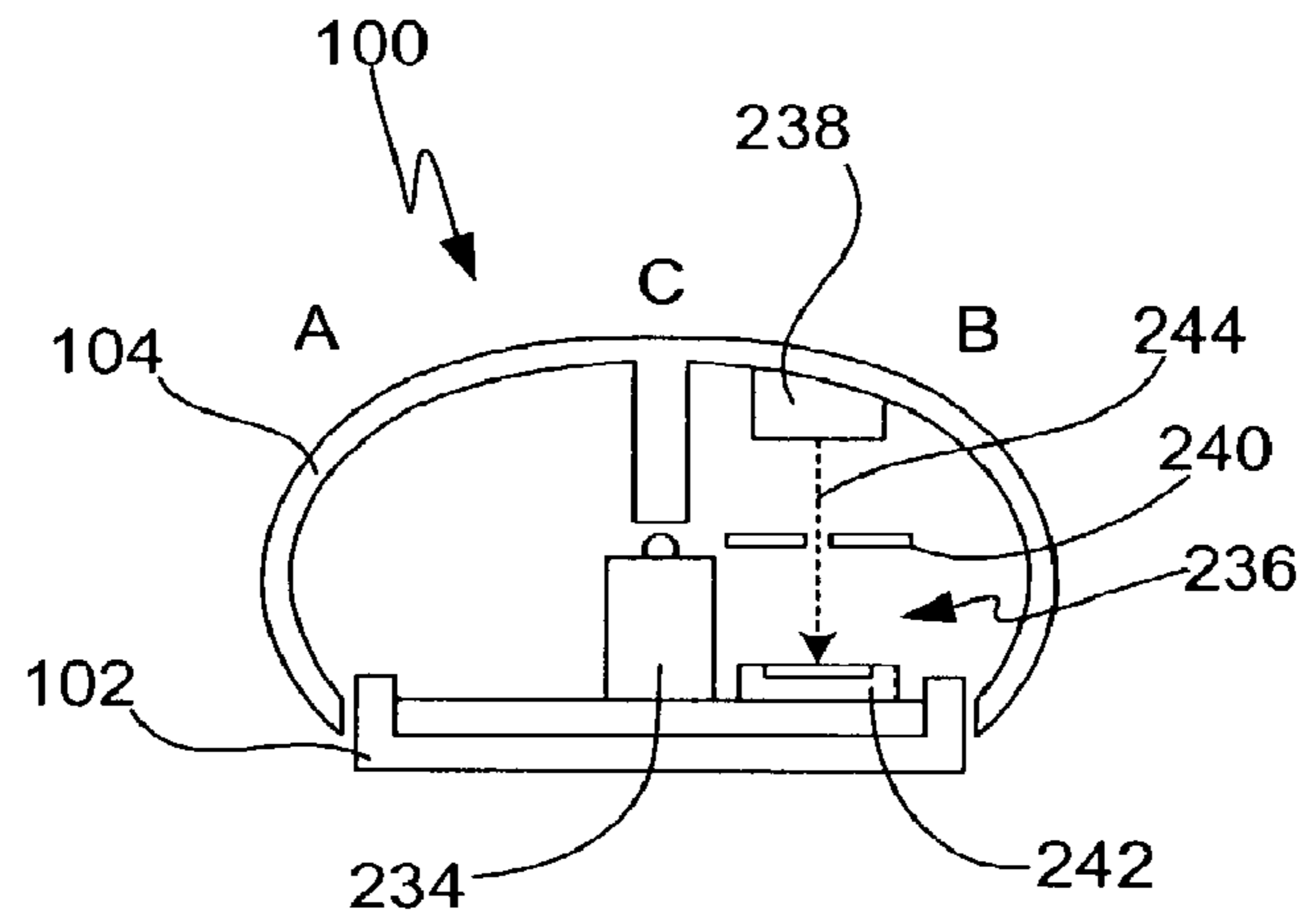

FIG. 13A

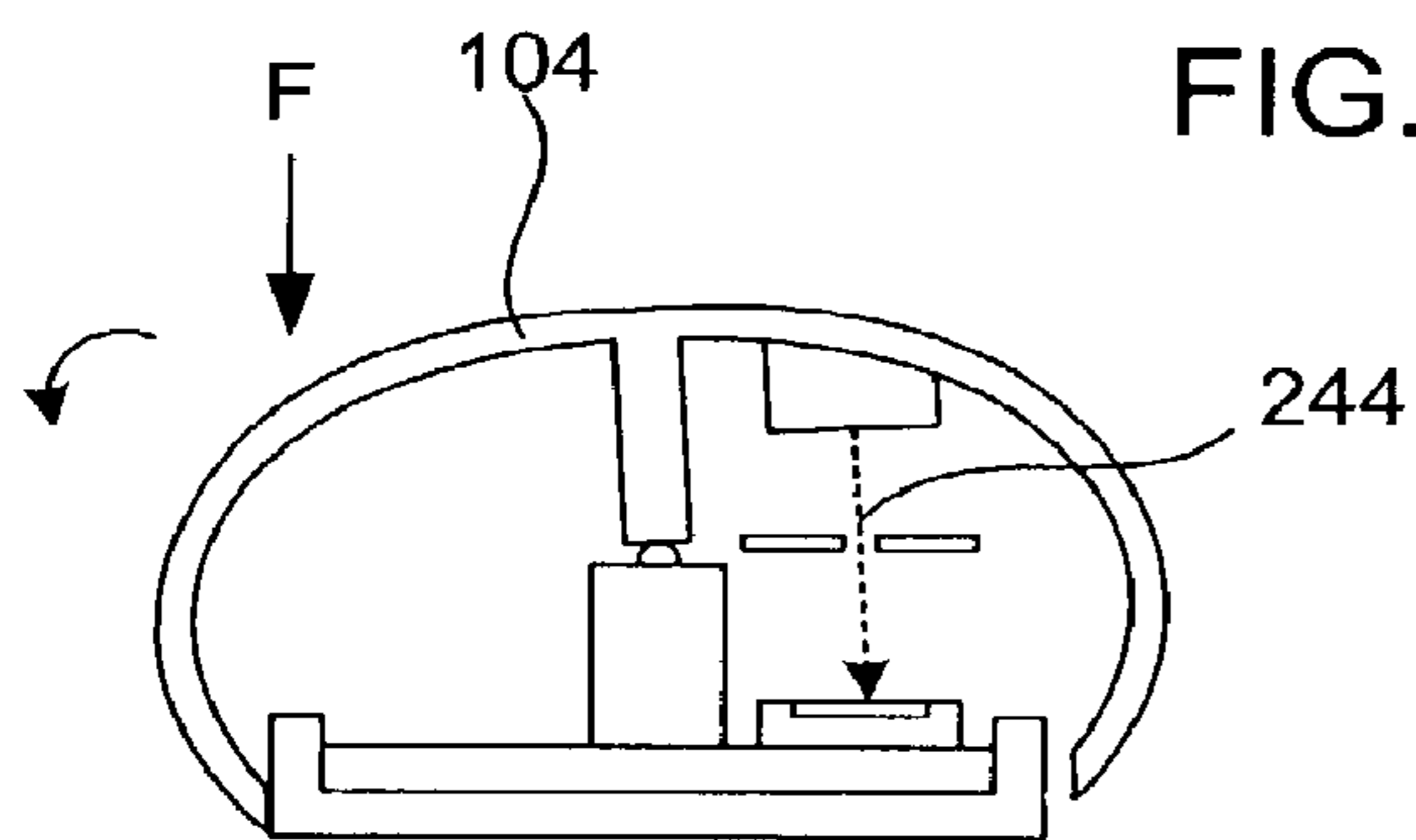

FIG. 13B

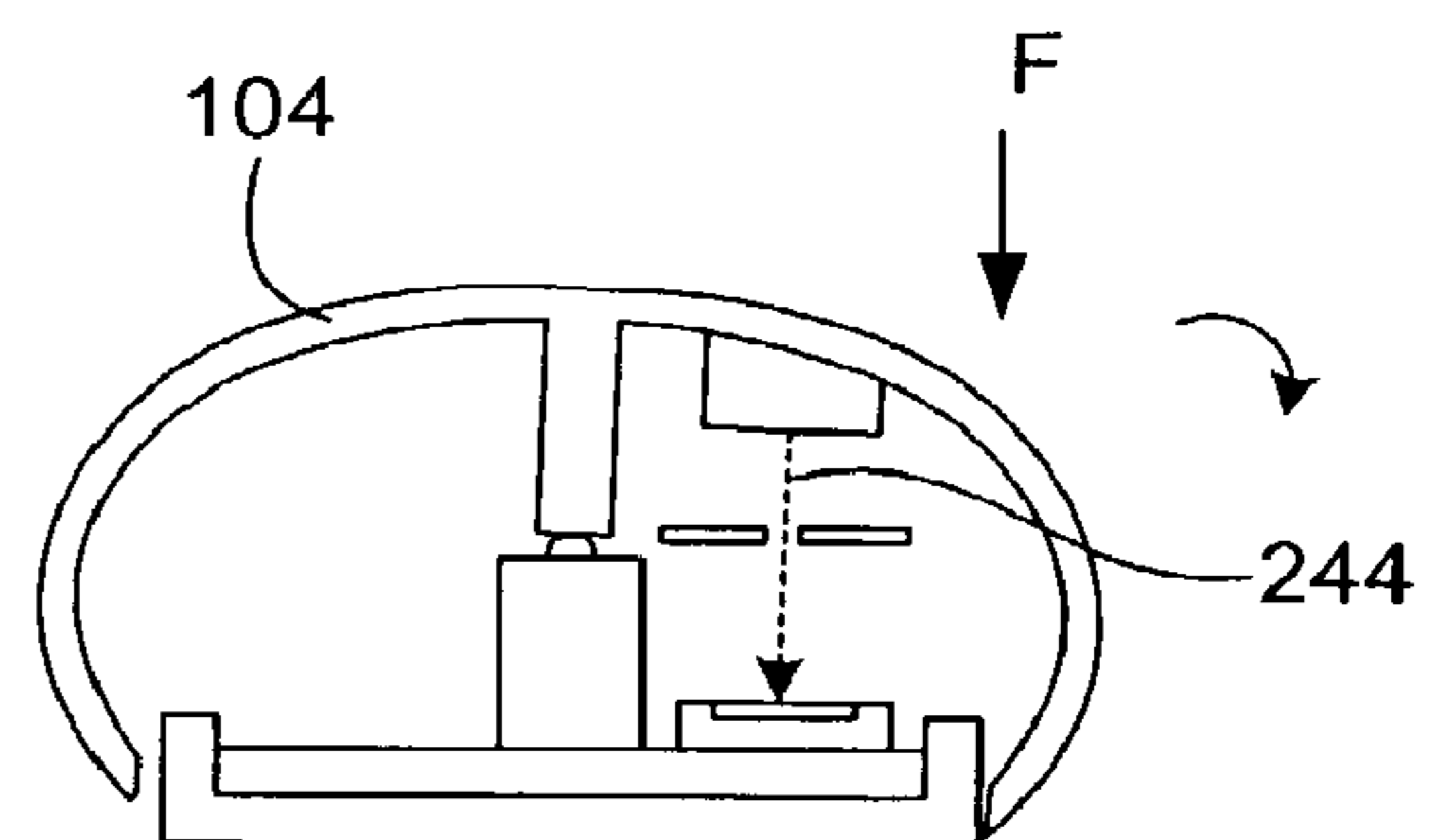

FIG. 13C

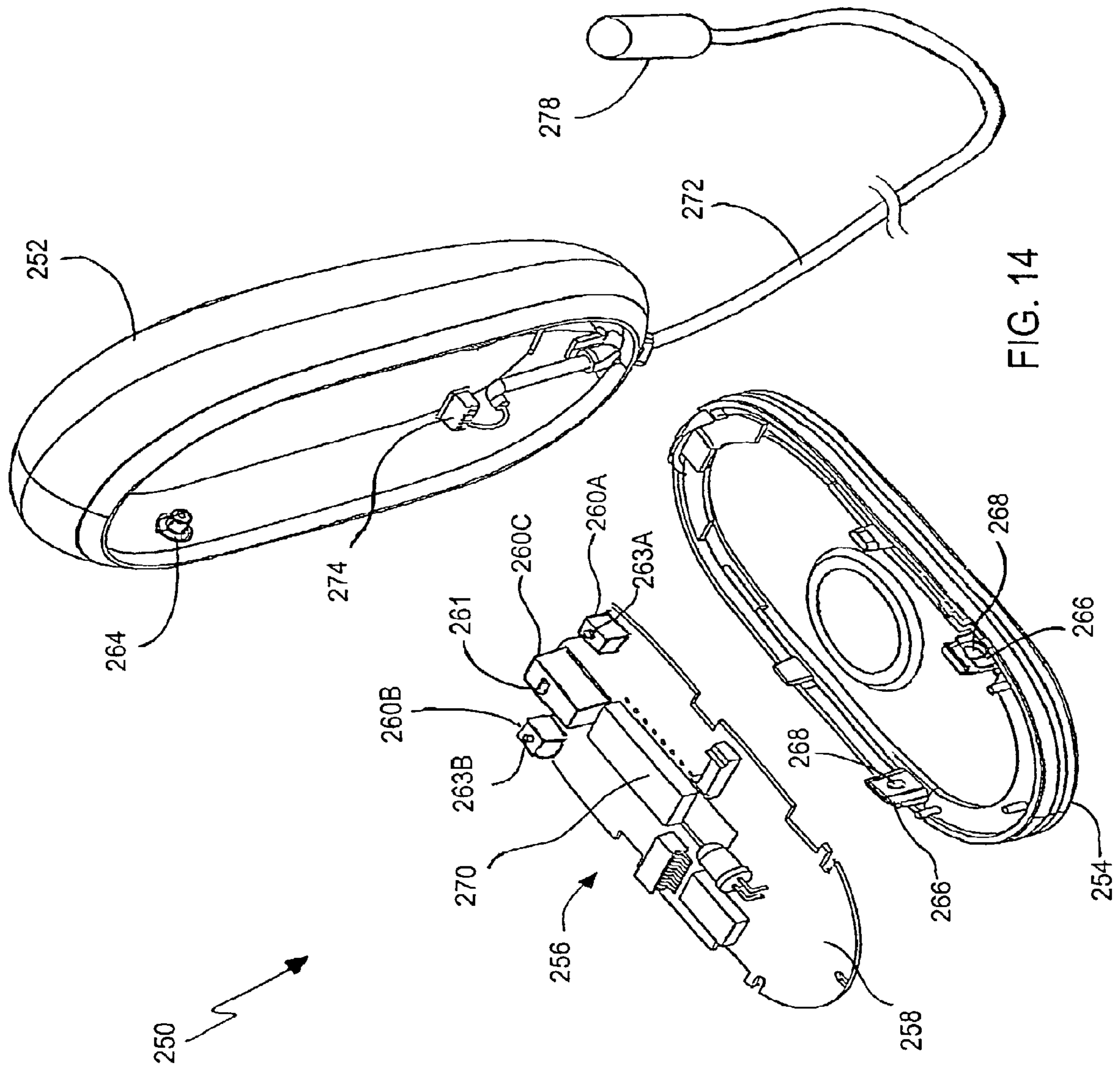

FIG. 14

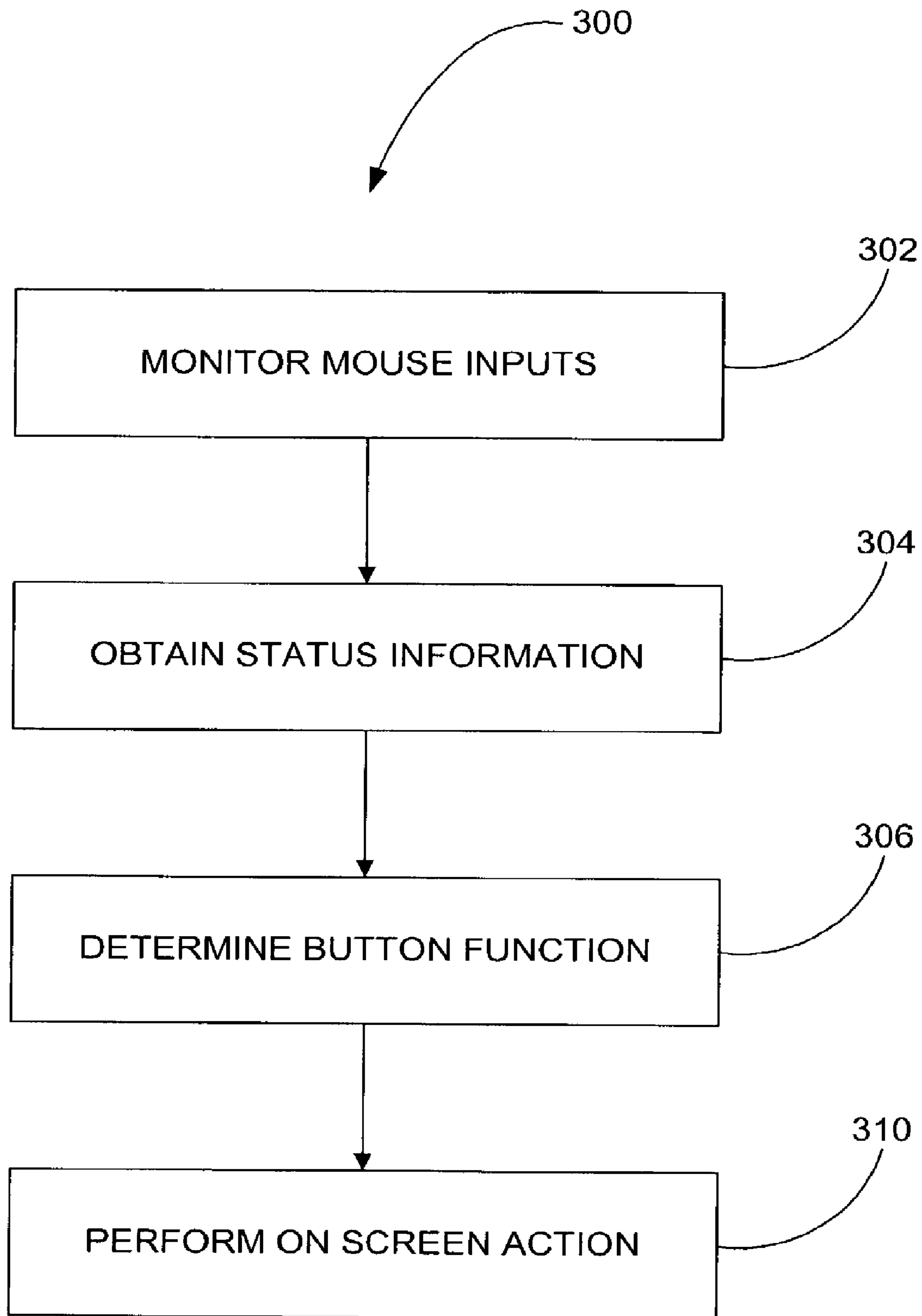

FIG. 15

MULTI-BUTTON MOUSE**CROSS REFERENCE TO RELATED APPLICATIONS**

This application is a continuation of U.S. patent application Ser. No. 10/209,537 filed on Jul. 30, 2002 now U.S. Pat. No. 7,233,318 and entitled "MULTI-BUTTON MOUSE," which claims priority of U.S. Provisional Patent Application No. 60/364,400 filed on Mar. 13, 2002 and entitled "MULTI-BUTTON MOUSE," both of which are hereby incorporated herein by reference.

BACKGROUND OF THE INVENTION**1. Field of the Invention**

The present invention relates generally to input devices. More particularly, the present invention relates to mice having multiple button functionality.

2. Description of the Related Art

Most computer systems, as for example general purpose computers such as portable computers and desktop computers, receive input from a user via an input device such as a mouse. As is generally well known, the mouse allows a user to move an input pointer (e.g., cursor) and to make selections with respect to a graphical user interface (GUI). The mouse generally includes a trackball, which is located on the underside of the mouse and which rolls when the mouse moves thus translating the motion of the users hand into signals that the computer system can use. The movement of the trackball generally corresponds to the movement of the input pointer. That is, by positioning the mouse on a desktop and moving it thereon, the user can move the input pointer in similar directions with respect to the GUI. An optical sensor may alternatively be used to track the movement of the mouse. The mouse also conventionally includes one or more buttons, which are located on the top side of the mouse housing. These one or more buttons, when selected, can initiate a GUI action such as menu or object selections. The one or more buttons are typically provided by one or more button caps that move relative to the mouse housing.

Although mice designs such as these work well, there are continuing efforts to improve their form, feel and functionality.

SUMMARY OF THE INVENTION

This invention relates in one embodiment to a method of sending signals corresponding to multiple button functionalities from a unibody mouse to an electronic system. The unibody mouse has a single movable housing component that cooperates with and is movably coupled with a base housing component that supports the unibody mouse on a surface. The method is performed by at least the following: associating the multiple button functionalities with specific portions of the single movable housing component, activating each of the multiple button functionalities by moving the single movable housing component to different positions relative to the base housing component wherein the single movable housing component has at least two degrees of freedom relative to the base housing component, generating a clicking action by moving the movable housing component relative to the base housing component along at least one of the at least two degrees of freedom, and sending a signal to the electronic system based upon the clicking action.

This invention relates in one embodiment to a method of configuring a multi-function mouse having a single movable

housing component being movably coupled to an associated base housing component that supports the multi-function mouse on a surface. The method includes at least the following operations: assigning a number of distinct button zones to the single movable housing component, interpreting a signal received from each assigned button zone as a corresponding button function, and performing the button function corresponding to the signal received from the mouse.

This invention relates in one embodiment to computer program product executable by a processor for configuring a multi-function mouse having a single movable housing component being movably coupled to an associated base housing component that supports the multi-function mouse on a surface. The computer program product includes computer code for assigning a number of distinct button zones to the single movable housing component, computer code for interpreting a signal received from each assigned button zone as a corresponding button function, computer code for performing the button function corresponding to the signal received from the mouse, and computer readable medium for storing the computer code.

In yet another embodiment of the invention, software encoded in one or more computer readable media in an electronic system is disclosed. When executed the software operates to assign a number of distinct button zones to a single movable housing component of a user input device communicatively coupled with the electronic system, the single movable housing component being movably coupled to an associated base housing component that supports the user input device on a surface, the single movable housing component being capable of movement along at least two degrees of freedom relative to the base housing component, associate a button function with each assigned button zone, interpret a signal received from the user input device, the signal being produced in the user input device and transmitted to the electronic system as a result of actuating a button zone, the button zone being actuated as a result of moving the single movable housing component relative to the base housing component to actuate an associated movement indicator configured to sense a movement of the associated button zone, wherein interpreting the signal involves at least determining which button zone was actuated, and implement a specific button function corresponding to the associated actuated button zone, the button function corresponding to an action on a display.

Another embodiment of the invention describes a method of configuring a multi-function mouse having a single movable housing component being movably coupled to an associated base housing component that supports the multi-function mouse on a surface, the method is carried out by performing at least the following operations: assigning a number of distinct button zones to the single movable housing component, interpreting a signal received from each assigned button zone as a corresponding button function, and performing the button function corresponding to the signal received from the mouse.

A system is described that includes a unibody user input device having multiple assigned button zones in a single movable housing component of the user input device, wherein each button zone has an associated button functionality and all of said multiple button functionalities are incorporated into the single movable housing component, the single movable housing component being movably coupled to a base housing component that supports the mouse along a surface, wherein the movable housing component is capable of movement along at least two degrees of freedom relative to the base housing component, wherein actuation of a single

button zone is achieved by moving the movable housing component relative to the base housing component to actuate an associated movement indicator configured to sense a movement of the associated button zone, a display, and a processor communicatively coupled with the mouse, the processor configured to interpret a signal received from the user input device, the signal being produced in the user input device as a result of the actuation of a button zone, wherein the interpretation of the signal involves at least the determination of which button zone was actuated, the processor being further configured to implement a specific button function corresponding to the associated actuated button zone, the button function corresponding to an action on the display.

BRIEF DESCRIPTION OF THE DRAWINGS

The invention will be readily understood by the following detailed description in conjunction with the accompanying drawings, wherein like reference numerals designate like structural elements, and in which:

FIG. 1 is a perspective diagram of an input device, in accordance with one embodiment of the present invention.

FIG. 2 is a simplified side view of a unibody mouse, in accordance with one embodiment of the present invention.

FIG. 3 is a simplified side view of a unibody mouse, in accordance with one embodiment of the present invention.

FIGS. 4A-4B are simplified rear views of a unibody mouse, in accordance with one embodiment of the present invention.

FIG. 5 is a perspective view of a unibody mouse, in accordance with one embodiment of the present invention.

FIGS. 6A-6F are top views of a unibody mouse, in accordance with several embodiments of the present invention.

FIG. 7 is a simplified top view of a unibody mouse, in accordance with one embodiment of the present invention.

FIG. 8 is a top view, in cross section, of a unibody mouse, in accordance with one embodiment of the present invention.

FIGS. 9A-9F are side elevation views, in cross section, of a unibody mouse, in accordance with several embodiments of the present invention.

FIGS. 10A-10C are side elevation views, in cross section, of a unibody mouse, in accordance with several embodiments of the present invention.

FIGS. 11A-11B are side elevation views, in cross section, of a unibody mouse, in accordance with one embodiment of the present invention.

FIG. 12 is a side elevation view, in cross section, of a unibody mouse, in accordance with an alternate embodiment of the invention.

FIGS. 13A-13C are side elevation views, in cross section, of a unibody mouse, in accordance with one embodiment of the present invention.

FIG. 14 is a perspective view of a unibody mouse, in accordance with one embodiment of the present invention.

FIG. 15 is a flow diagram of mouse processing, in accordance with one embodiment of the present invention.

DETAILED DESCRIPTION OF THE INVENTION

Embodiments of the invention are discussed below with reference to FIGS. 1-15. However, those skilled in the art will readily appreciate that the detailed description given herein with respect to these figures is for explanatory purposes as the invention extends beyond these limited embodiments.

FIG. 1 is a perspective diagram of a user operated input device 20, in accordance with one embodiment of the invention. The user operated input device 20 is configured to allow a user to move an input pointer (e.g., cursor) and to perform an

action on a display screen. By way of example, the input pointer may be displayed via a Graphical User Interface (GUI) on a display screen. Although not shown in FIG. 1, the display screen is typically part of an electronic system such as a computer system. For example, the computer-based electronic system may correspond to a general purpose computer, such as a desktop computer or a portable computer. The user input device is typically connected to the electronic device via a data transmission cord 21, although other types of connections may be used, as for example, wireless connections.

The input device 20 generally includes a device housing 22 that provides a structure for moving the device 20 along a surface and for gripping the device 20 for movement thereof. The device housing 22 also helps to define the shape or form of the device 20. That is, the contour of the device housing 22 embodies the outward physical appearance of the device 20. The device housing 22 also provides a structure for enclosing, containing and/or supporting the internal components of the device 20. Although not shown, the internal components may correspond to electrical and/or mechanical components for operating the device 20. For example, the internal components may include a track ball or optical assembly for monitoring the movement of the input device 20 along a surface and for sending signals corresponding to the movements to the electronic system. In most cases, the signals produced by these components direct the input pointer to move on the display screen in a direction similar to the direction of the device as it is moved across a surface. For example, when the input device is moved forward or backwards, the input pointer is moved vertically up or down, respectively, on the display screen. In addition, when the input device is moved from side to side, the input pointer is moved from side to side on the display screen.

In one embodiment, the user operated input device includes one or more button zones 24. The button zones 24 represent regions of the device 20 that may be actuated by a user to implement one or more button functions associated with performing actions on a display screen. By way of example, the button functions may include selecting an item on the screen, opening a file or document, executing instructions, starting a program, viewing a menu, and/or the like. The button functions may also include functions that make it easier to navigate through the electronic system, as for example, zoom, scroll, open different menus, home the input pointer, perform keyboard related actions such as enter, delete, insert, page up/down, and the like.

The manner in which the button zones 24 may be implemented can be widely varied. For example, the button zones 24 may be provided by a mechanical button (or buttons) that each provide a clicking action for implementing an on-screen action. In most cases, the mechanical button includes a button cap or scroll wheel that works independent of or moves relative to the input device housing 22. For example, the button cap may pivot relative to the housing. The button zones may also be provided by a unified button/housing that incorporates the functionality of a button (or buttons) directly into the input device housing 22, i.e., the button functionality and a substantial portion of the housing are combined (as opposed to attaching separate button caps to or through the device housing). In a unified button housing, the button zones may be provided by different portions of the device housing that each provide a clicking action for implementing an on-screen action. In essence, the device housing serves as a button (or buttons) of the input device 20. The button zones may also be provided by a combination of the above (e.g., button caps and unified button housing).

5

In any of the examples above, the clicking actions are generally arranged to actuate one or more movement indicators (not shown) contained inside the device housing 22. The movement indicators are configured to sense movements of the button zones during the clicking action and to send signals corresponding to the movements to the electronic system. By way of example, the movement indicators may be switches, sensors and/or the like.

The clicking action(s) may, for example, be used to implement a single click, a double click and/or a dragging and dropping function. As is generally well known, a single click often selects an item on the screen, a double click often opens a document or launches a program, and dragging and dropping generally makes it easy to move an item on the screen. In order to perform a single click using the device 20, the user presses and releases at least one of the button zones 24. In order to perform a double click using the device 20, the user quickly presses and releases at least one of the button zones 24 twice. In order to perform a drag and drop function, the user first positions the pointer or cursor over an item on the screen (by moving the mouse along the flat surface) and presses and holds down at least one of the button zones 24 so as to select the item. Thereafter, the user, while still holding down the at least one of the button zones 24, moves the pointer to a desired position on the screen (by moving the mouse along the flat surface) and subsequently releases the at least one of the button zones 24.

In order to implement multiple button functionalities, the input device 20 is generally divided into several independent and spatially distinct button zones, as for example, button zones 24A and 24B. Each of these button zones may correspond to a distinct button function. For example, the first button zone 24A may correspond to selecting an item on the display screen (e.g., standard left click) and the second button zone 24B may correspond to showing a menu on the display screen (e.g., standard right click).

In one embodiment, the input device 20 integrates at least one of the button zones 24A or 24B directly into a portion of the device housing 22. That is, the device housing 22 acts like a button such that at least one of the multiple button functionalities may be implemented by pressing on the device housing 22 rather than on a separate mechanical button. The other button zone 24A or 24B may correspond to another portion of the device housing 22 as above, or to a mechanical button such as button caps, scroll wheels and the like. In the illustrated embodiment, the button zones 24 correspond to different portions of the device housing 22 and thus the device housing itself is used to implement all of the multiple button functions of the input device. Although only two button zones are shown in FIG. 1, the input device may include one or more button zones.

FIG. 2 is a side view of a unibody mouse 50, in accordance with one embodiment of the invention. By way of example, the unibody mouse 50 may correspond to the user operated input device 20 shown in FIG. 1. The unibody mouse 50 generally includes a mouse housing 51 that provides a structure for moving the mouse along a surface, for gripping the mouse for movement thereof and for implementing at least one button function of the mouse 50. The term "unibody" herein refers to a mouse that integrates at least one button function directly into the mouse housing 51, i.e., pressing on the mouse housing 51 creates a clicking action. As such, any part of the hand, from finger to thumb to palm, can trigger a clicking action.

The mouse housing 51 may be widely varied. In the illustrated embodiment, the mouse housing 51 includes a movable base 52 and a button body 54. The movable base 52 is con-

6

figured to moveably support the mouse 50 during use thereof, i.e., the base 52 makes moving contact with a surface such as a desktop or mouse pad. In most cases, the movable base 52 supports a position detecting mechanism so as to track the position of the mouse 50 as it is moved along the surface. By way of example the position detecting mechanism may be a trackball mechanism or an optical sensor. The position detecting mechanism is generally configured to provide information to a computer so that the movement of the pointer on the screen corresponds to the movement of the mouse on the surface.

The button body 54, on the other hand, is configured to move relative to the base 52 so as to provide a clicking action that implements the button functionality of the mouse 50. The entire surface of the body 54 above the base 52 acts as a single or multiple button. The clicking action (e.g., the movement of the body 54 relative to the base 52) may be provided through one or more degrees of freedom (DOF). The degrees of freedom may be implemented through one or more rotations, pivots, translations, flexes (and/or the like) relative to the base 52. By way of example, the button body 54 may be coupled to the base 52 via one or more pin joints, slider joints, ball and socket joints, flexure joints and the like.

In one embodiment, a single DOF is used to implement a single clicking action. For example, as shown in FIG. 3, a single clicking action may be implemented by a body 62 that pivots relative to a base 64. By way of example, the body 62 and base 64 may generally correspond to the body and base shown in FIG. 2. The body 62 typically pivots about an axis 66. In this example, the body 62 is capable of moving between a first position (shown by a solid line) and a second position (shown by a dotted line) when a force F is applied to the body 62. The force F may be any downward force on the mouse 60, whether from a finger, palm or hand that results in a clicking action. In one implementation, the button body 62 may be spring biased so as to place the button body 62 in an unactuated position such as for example the first position shown by the solid lines. The spring bias may be provided by a separate spring or a movement indicator that includes a spring action.

In another embodiment, a single DOF is used to implement multiple clicking actions. For example, as shown in FIGS. 4A and 4B, a multiple clicking action may be implemented by a body 72 that pivots relative to a base 74. By way of example, the body 72 and base 74 may generally correspond to the body and base shown in FIG. 2. The body 72 typically pivots about an axis 76. As shown in FIG. 4A, the body 72 is capable of moving between a first position (shown by a solid line) and a second position (shown by dotted lines) when a force F_1 is applied to a left side 78 of the body 72, and as shown in FIG. 4B, the body 72 is capable of moving between a first position (shown by a solid line) and a third position (shown by dotted lines) when a force F_2 is applied to a right side 80 of the body 72. The forces F_1 and F_2 may be any downward force on the mouse 70, whether from a finger, palm or hand that results in a clicking action. In one implementation, the button body 72 may be spring biased so as to place the button body 72 in an unactuated position such as for example the first position shown by the solid lines. The spring bias may be provided by a separate spring or a movement indicator that includes a spring action.

In yet another embodiment, multiple DOF's are used to implement multiple clicking actions. For example, a multiple clicking action may be implemented by a combination of pivots, as for example the pivots shown in FIGS. 3 and 4. Referring to FIG. 5, a unibody mouse 90 that includes a body 92 that pivots in two directions relative to a base 94 is shown. By way of example, the body 92 and base 94 may generally

correspond to the body and base shown in FIG. 4. The pivots may be implemented using a variety of joints including pivot joints, flexure joints and the like. As shown by the arrows, the body 92 can pivot about a first axis 96 and a second axis 98. The positions of the two axis 96, 98 may be widely varied so as to allow a plurality of body positions relative to the base. In the illustrated embodiment, the two axes 96, 98 are orthogonal (or perpendicular) to one another. This arrangement allows the body to move between a plurality of positions when a force is applied to different portions of the body 92. For example, the body 72 may be capable of moving between an initial position (no pivot) and a left tilt position (pivot about both axis) when a force is applied to a left front portion A of the body 72, between an initial position and a right tilt position (pivot about both axis) when a force is applied to a right front portion B of the body 72, and between an initial position and a middle tilt position (pivot about a single axis) when a force is applied to a middle front portion C of the body 72. The force may be any downward force on the mouse 90, whether from a finger, palm or hand that results in a clicking action. In one implementation, the button body 92 may be spring biased so as to place the button body 92 in an unactuated position such as for example the first position shown by the solid lines. The spring bias may be provided by a separate spring or a movement indicator that includes a spring action.

It should be noted that pivots are not a limitation and that other types of DOF, as well as other types of joints may be used. For example, the mouse may include a pivot/translating joint, pivot/flexure joint, pivot/ball and socket joint, translating/flexure joint, a flexure joint, a ball and socket joint, and the like so as to provide two or more degrees of freedom.

Multiple clicking actions may be arranged in a variety of ways to produce one or more button zones corresponding to one or more button functions. Button zones, as used in conjunction with a unibody design, refers to a region of the housing that represents a particular button function. The multiple clicking actions may or may not represent multiple button zones. That is, although the body moves to more than one position, the mouse may be configured to have only one button zone or it may be configured to have two or more button zones.

In one embodiment, the number of clicking actions corresponds to the number of button zones. That is, each independent movement of the body relative to the base implements a distinct button function. In a specific example, the mouse shown in FIGS. 4A and 4B, which can tilt to the left or the right may be used to implement different button functions such as a conventional right click and left click.

In another embodiment, the number of clicking actions corresponds to a different number of button zones. For example, a single button zone may be arranged to encompass two or more clicking actions so that each of the clicking actions implements the same button function. In a specific example, the mouse shown in FIG. 5, which can tilt to the left, right and forward may be used to implement only two button functions such as a conventional right click and left click. In cases such as this, the forward tilt may be combined with the right tilt to produce a button zone associated with a right click or with the left tilt to produce a button zone associated with a left click.

The distribution of the button zones may be widely varied. For example, the button zones may be positioned almost anywhere on the mouse (e.g., front, back, sides or the like). Further, the button zones may be formed from almost any shape whether simple (e.g., squares, circles, ovals, triangles, rectangles, polygons, and the like) or complex (e.g., random shapes). The shape of multiple button zones may have iden-

tical shapes or they may have different shapes. In addition, the size of the button zones may vary according to the specific needs of each device. In most cases, the size of the button zones corresponds to a size that allows them to be easily manipulated by a user (e.g., the size of a finger tip or larger). Moreover, any number of button zones may be used. In most cases, the number of button zones correspond to the number of button functionalities offered by the mouse 50.

Still referring to FIG. 2, the movable base 52 and button body 54 provide a mouse housing for containing the electronics that generate control signals associated with moving the input pointer and performing actions on a display screen. By way of example, the electronics may be printed circuit boards (PCB), processors, encoders, movement indicators, wires, and the like. The base 52 and body 54 may also define the shape or form of the mouse 50. That is, the contour of the base 52 and body 54 may embody the outward physical appearance of the mouse 50. The contour may be rectilinear, curvilinear or both. In the illustrated embodiment, a bottom side 55 of the base 52 has an external contour (e.g., rectilinear) that substantially conforms to the contour of a flat surface such as a desktop and a top side of the mouse housing has an external contour that substantially conforms to the contour of the inside surface of a hand (e.g., curved). For example, as shown in FIG. 2, a back portion 58 of the body 54 has an external contour (e.g., curved) that is configured to substantially conform to the contour of the palm-side surface of a hand, and a front portion 59 of the body 54 has an external contour (e.g., curved) that is configured to substantially conform to the contour of the fingers of the hand when the palm side surface of the hand is placed on the back portion 58 of the body 54. As shown, the button body represents a substantial portion of the entire mouse housing.

In one embodiment, the button functions of the button zones are implemented via movement indicators located inside the mouse housing and underneath the button zones. The movement indicators may be any combination of switches and sensors. Switches are generally configured to provide pulsed or binary data such as activate (on) or deactivate (off). By way of example, an underside portion of the body may be configured to contact or engage (and thus activate) a switch when the user presses on the button zone. The sensors, on the other hand, are generally configured to provide continuous or analog data. By way of example, the sensor may be configured to measure the position or the amount of tilt of the body relative to the base when a user presses on the button zone.

The arrangement of movement indicators may be widely varied. In one embodiment, the mouse 50 may include a movement indicator for each button zone. That is, there may be a movement indicator corresponding to every button zone. For example, if there are two button zones, then there will be two movement indicators.

In another embodiment, the movement indicators may be arranged in a manner that simulates the existence of a movement indicator for each button zone. For example, two movement indicators may be used to form three button zones. In another embodiment, the movement indicators may be configured to form larger or smaller button zones. By way of example, this may be accomplished by careful positioning of the movement indicators or by using more than one movement indicator for each button zone. It should be noted that the above embodiments are not a limitation and that the arrangement of movement indicators may vary according to the specific needs of each device.

FIGS. 6A-6F are top views of a unibody mouse 30 having a plurality button zones 32 integrated into a housing 34 of the

unibody mouse **30**, in accordance with several embodiments of the invention. As shown, the dotted lines represent areas of the housing **34** that make up an individual button zone, i.e., an area of the housing that operates as a separate button. By way of example, the unibody mice **30** shown in FIGS. 6A-6F may generally correspond to the user operated input device **20** shown in FIG. 1 or the mouse **50** shown in FIG. 2. Each of the Figures is arranged to show various distributions of the button zones.

In FIG. 6A, the unibody mouse **30** includes a pair of button zones **32** that are positioned in the front **36** of the unibody mouse **30**. In this example, one of the button zones **32A** is positioned on the left side **38** of the unibody mouse **30** and one of the button zones **32B** is positioned on the right side **40** of the unibody mouse **30**. Furthermore, the button zones **32** are symmetrical, i.e., they are mirror images of each other and therefore they have the same size and shape.

In FIG. 6B, the unibody mouse **30** includes a pair of button zones **32A** and **32B** that are positioned to the sides **38**, **40** of the unibody mouse **30**. In this example, the button zones **32** extend from the front **36** of the mouse **30** to the back **42** of the mouse **30**. Similar to FIG. 2A, the button zones **32** are symmetrical, i.e., they are mirror images of each other and therefore they have the same size and shape.

In FIG. 6C, the unibody mouse **30** includes a pair of button zones **32A** and **32B** that are not symmetrical, i.e., they have different sizes and shapes. In this example, one of the button zones **32** extends over an imaginary centerline **44** that divides the mouse **30** in half.

In FIG. 6D, the unibody mouse **30** includes a pair of button zones **32A** and **32B** that are positioned in the front **36** and back **42** of the unibody mouse **30**. In this example, each of the button zones **32** extends from one side **38** to the opposite side **40** of the mouse **30**. Furthermore, each of the button zones **32** are symmetrical, i.e., they are mirror images of each other and therefore they have the same size and shape.

In FIG. 6E, the unibody mouse **30** includes three button zones **32A-32C** that are positioned in the front **36** of the unibody mouse **30**. In this example, one of the button zones **32A** is positioned on the left side **38** of the mouse, one of the button zones **32C** is positioned in the center **44** of the mouse **30**, and one of the button zones **32B** is positioned on the right side **40** of the mouse **30**. Furthermore, the button zones **32** are not symmetrical, i.e., they are not mirror images of each other and therefore they have different sizes and shapes.

In FIG. 6F, the unibody mouse **30** includes four button zones **32A-32D** that are positioned in the four corners of the unibody mouse **30**. In this example, the button zones **32** are symmetrical, i.e., they are mirror images of each other and therefore they have the same size and shape.

It should be noted that the button zone distributions shown in FIGS. 6A-6F are not a limitation and that the distribution may vary according to the specific needs of each device. That is, there are alterations, permutations, and equivalents, which fall within the scope of the examples given above.

FIG. 7 is a simplified top view of a unibody mouse **81**, in accordance with one embodiment of the present invention. By way of example, the unibody mouse **81** may generally correspond to the unibody mouse shown in FIG. 2, **5** or **6E**. The mouse **81** includes three movement indicators—a first switch **83** housed beneath a forward left portion A of a button body **82**, a second switch **84** housed beneath a forward left portion B of the body **82** and a third switch **85** housed beneath a forward middle portion C of the body **82**. A left tilt clicking action tends to activate the first switch **83**, a right clicking action tends to activate the second switch **84** and a middle tilt clicking action tends to activate the third switch **85**. The

signals sent by the activated switches **83-85** may be controlled, as for example via software, so as to produce one or more button functions. For example, the mouse **81** may be configured to act as a single button mouse when any of the portions A-C are pressed (A-C is equal to a single button zone). The mouse **81** may also be configured to act as a dual button mouse when portions A and B are individually pressed (FIG. 6A), when portions AC and B are individually pressed (FIG. 6C) or when portions A and BC are individually pressed. The mouse **81** may also be configured to act as a triple button mouse when respective portions A, B or C are individually pressed (FIG. 6E), or the like.

FIG. 8 is a top elevation view, in cross section, of a mouse **100**, in accordance with one embodiment of the present invention. By way of example, the mouse **100** may generally correspond to the mouse **50** shown in FIG. 7. The mouse **100** includes a base **102** and a body **104** that cooperate to enclose a plurality of internal components **106**. The internal components may be electrical and/or mechanical components. In the illustrated embodiment, the electrical components include a printed circuit board **108**, a plurality of movement indicators **110** and a microcontroller **112**. The printed circuit board **108** is attached to the base **102**, and the movement indicators **110** and microcontroller **112** are attached to the printed circuit board **108**. The movement indicators **110**, which may be mechanical, optical or magnetic, provide signals to the microcontroller and the microcontroller provides an output (signal **111**) for use by an electronic device. By way of example, the output may be sent via a wired or wireless connection.

The base **102** provides a platform for sliding the mouse **100** along a surface and for supporting different components of the mouse **100**, as for example, the internal components **106** and the body **104**. In order to provide a clicking action, the body **104** is configured to move relative to the base **102**. The clicking action (e.g., the movement of the body **104** relative to the base **102**) may be provided through one or more degrees of freedom (DOF). The degrees of freedom may be implemented through one or more rotations, pivots, translations, flexes (and/or the like) relative to the base **102**. By way of example, the button body **104** may be coupled to the base **102** via one or more pin joints, slider joints, ball and socket joints, flexure joints and the like. In the illustrated embodiment, the body has at least two degrees of freedom relative to the base so as to allow the body to move in multiple directions. The components used to implement the at least two degrees of freedom DOF may be widely varied.

To elaborate, the body **104** is coupled to the base **102** via a two axis joint **113**. The two axis joint **113** is configured to allow the body **104** to move about a longitudinal axis **118** and a latitudinal axis **120**. The position of the two axes **118**, **120** may be widely varied. For example, the latitudinal axis **120** may be positioned towards the back of the mouse **100** (as shown), in the middle of the mouse **100**, or towards the front of the mouse **100**. In addition, the longitudinal axis **118** may be positioned in the center of the mouse **100** (as shown), towards the left side of the mouse **100** or towards the right side of the mouse **100**. The position of the two axis **118**, **120** generally determines the type of clicking actions. In the illustrated embodiment, the axis arrangement produces at least three clicking actions—a right click, a middle click and a left click. With regards to the right click, if the user presses on the right front portion of the body **104**, the body **104** tilts forward and to the right. With regards to the left click, if the user presses on the left front portion of the body **104**, the body **104** tilts forward and to the left. With regards to the middle click, if the user presses on the middle front portion of the body **104**, the body **104** tilts forward.

11

In one embodiment, the two axis joint **113** is a pivot/flexure joint that includes a pivot and a bendable flexure (e.g., spring). The pivot generally includes a pivot pin that is rotatable within a pivot support. In one example, the pivot pin is coupled to the body **104** and the pivot support **116** is coupled to the base **102** through the bendable flexure. In this example, the pivot allows the body **104** to rotate about the latitudinal axis **120**, and the bendable flexure allows the body **104** to pivot about the longitudinal axis **118** (thereby giving the mouse two degrees of freedom).

The moving body **104** provides a platform for actuating the movement indicators **110** disposed underneath the body **104**. That is, if a user implements a click, the body tilts forward and to the right, middle or left thereby actuating one or more of the movement indicators **110**. When activated, the movement indicators send signals to the controller **112**. The controller may process the signals directly or it may pass the signals onto a host device for processing. The processing step is generally configured to produce a control signal corresponding to a right button click when the user presses on the right front portion of the mouse body **104**, a left button click when the user presses on the left front portion of the mouse body **104** and a middle button click when the user presses on the middle front portion of the mouse body **104**.

FIGS. **9A-9F** are side views, in cross section, of the mouse **100** (taken along sectional line **9-9'** in FIG. **8**), in accordance with several embodiments of the invention. Each of the Figures is arranged to show various arrangements for implementing the at least two degrees of freedom DOF. In FIG. **9A**, the body **104** is coupled to the base **102** via a pivot/flexure joint **120**. The pivot/flexure joint **120** includes a pair of pivot pins **122**, which extend from the inner periphery **124** of the body **104** and which engage a pivot support **126**. The pivot/flexure joint **120** also includes a flexure **128** that couples the pivot support **126** to the base **102**. As should be appreciated, the pivot joint allows the body **104** to pivot forward towards the front of the mouse **100**, and the flexure joint allows the body **104** to move to either side of the mouse **100**. This combination yields a body **104** that can tilt straight forward, right forward and left forward (or backwards if desired). In one implementation, the flexure is a bendable material such as plastic or metal. In the illustrated embodiment, the flexure is a spring. Any suitable spring may be used.

In FIG. **9B**, the body **104** is coupled to the base **102** via a double pivot joint **130**. The double pivot joint **130** includes an axle **132** which extends across the body **104**, and which engages a pair of pivot supports **134** attached to the body **104** (one on each side of the body). The double pivot joint **130** also includes a pivot pin **136**, which is coupled to the axle **132**, which extends in a direction orthogonal to the axle **132** and which engages a pivot support **138** attached to the base **102**. This combination yields a body that can tilt straight forward, right forward and left forward (or backwards if desired). The pivot joints (e.g., pivot pins and pivot supports) may alternatively be provided by ball and socket joints.

In FIG. **9C**, the body **104** is coupled to the base **102** via a double pivot joint **140**. The double pivot joint **140** includes first and second pivot pins **142**, and **144** that engage first and second pivot supports **146**, **148**, respectively. The second pivot pin is attached to an extension **145** of the body **104**. The first pivot support **146** is mounted to the base **102**, and the second pivot support **148** is mounted to the first pivot pin **142**. This combination yields a body that can tilt straight forward, right forward and left forward (or backwards if desired). The pivot joints (e.g., pivot pins and pivot supports) may alternatively be provided by ball and socket joints.

12

In FIG. **9D**, the body **104** is coupled to the base **102** via a pivot slider joint **150**. The pivot slider joint **150** includes a pivot pin **152** which is attached to an extension **154** of the body **104** and which engages a pivot support **156**. The pivot slider joint **150** also includes a slider **157**, which is attached to the pivot support **156** and which engages a slide support **158** that is mounted on the base **102**. This combination yields a body that can tilt right and left and translate upwards and downwards.

In FIG. **9E**, the body **104** is coupled to the base **102** via a ball and socket joint **160**. The ball and socket joint **160** includes a ball **162** that is attached the body **104**, and a socket **164** that is attached to the base **102**. The ball **162** is configured to engage the socket **164** so as to allow the body **104** to swivel relative to the base **102**. This combination yields a body **104** that can tilt to almost any point, as for example, forward straight, forward left, forward right, backwards straight, backwards right, backwards left, left, right or any point therebetween.

In FIG. **9F**, the body **104** is coupled to the base **102** via a flexure **170**. The flexure **170**, which is bendable, is attached to the body **104** and to the base **102**. The bendable nature of the flexure **170** allows the body **104** to tilt to almost any point, as for example, forward straight, forward left, forward right, backwards straight, backwards right, backwards left, left, right or any point therebetween. In one implementation, the flexure is a spring.

It should be noted that the joints shown in FIGS. **9A-9F** are not a limitation and that the joints may vary according to the specific needs of each device. That is, there are alterations, permutations, and equivalents, which fall within the scope of the examples given above.

FIGS. **10A-10C** are side views, in cross section, of the mouse **100** (taken along sectional line **10-10'** in FIG. **8**), in accordance with several embodiments of the invention. Each of the Figures is arranged to show various arrangements of the movement indicators. In these Figures, the mouse includes three movement indicators **200** which are mounted on the printed circuit board **108**, and three posts **180** which extend from the bottom surface of the body **104**. The posts **180** are arranged to engage a corresponding movement indicator **200** when the body **104** is moved from the unclicked position to the clicked position. The movement indicators **200** may be widely varied. For example, any combination of mechanical, optical (e.g., photo-interrupters) or magnetic (e.g., hall effect) switches may be used.

In FIG. **10A**, the mouse **100** includes three mechanical switches **200A-C**. The mechanical switches generally include an actuator element **202** configured to receive the corresponding post **180** when the body **104** is moved to the clicked position (e.g., when a downward force is applied to the body **102**). In the clicked position, the post **180** is configured to push against the actuator element **202** so as to activate the switch. For example, when a user presses on the left side of the body **104**, the left post **180A** pushes against the actuator element **202** of the left switch **200A** thereby activating the left switch **200A**. The actuator element typically moves between a deactivated position (e.g., upright) and an activated position (e.g., depressed). In most cases, the actuator element is spring biased in the deactivated position. The mechanical switches may be widely varied. For example, because the left and middle switches may be activated at the same when the user presses on the left side of the body, the mechanical switches may be configured to have actuator elements that activate with or without a clicking characteristics (e.g., feel or noise). As should be appreciated, a dual clicking feel when only a single clicking feel is suppose to be felt is generally undesir-

13

able to the user. In one implementation, therefore, the middle switch provides clicking characteristics while the left and right switches provide no clicking characteristics.

In FIG. 10B, the mouse 100 includes three optical switches 200A-C. Optical switches are similar to mechanical switches in that they have an activate and deactivate condition. Optical switches generally include a light source 190 and a light detector 192 for sensing light from the light source 190. Activation may occur when the detector 192 senses light or when it doesn't sense light. In the illustrated embodiment, activation occurs when the detector 192 does not sense light. The posts 180 are configured to block the light from the light source 190 when the body 104 is moved to the clicked position (e.g., when a downward force is applied to the body 102). In the clicked position, the post 180 is configured to be inserted between the light source 190 and the light detector 192 thereby blocking the light from reaching the detectors 192. For example, when a user presses on the left side of the body 104, the left post 180A moves between the light source 190A and the light detector 192A of the left optical switch 200A thereby activating the switch. Depending on the geometry of the mouse, the middle post may also engage the its optical switch when the user presses on the left side of the body. The manner in which these signals are differentiated may be implemented via software (e.g., when the left and middle are actuated, a left click signal may be implemented in the electronic system).

In FIG. 10C, the mouse includes an arrangement of mechanical and optical switches. In the illustrated embodiment, the mouse 100 includes one mechanical switch 200C and two optical switches 200A and B. The mechanical switch is positioned in the middle, and the optical switches are positioned to the sides.

It should be noted that using three switches is not a limitation and that the number of switches may vary according to the specific needs of each device. For example, two or more switches may be used. The number of switches generally depends on the number of button functionalities available by the mouse.

FIGS. 11A-11B are side views, in cross section, of the mouse 100 (taken along sectional line 10-10' in FIG. 8), in accordance with an alternate embodiment of the present invention. In this embodiment, the mouse 100 includes a post 210, a first switch 212, a second switch 214, and a flexure 216. The post 210, which extends from the body 104, is configured to engage the flexure 216 when the body 104 is moved from a first position (as shown in FIG. 11A) to a second position (as shown in FIG. 11B). The flexure 216, which is attached to the base 102, is configured to bend so as to engage one of the switches 212, 214 when the post 210 moves between the first and second positions. For example, as shown in FIG. 11B, when a force F is applied to the right side of the body 104, the flexure 216 bends outward to the right, thus engaging and subsequently moving an actuator element of the second switch 214. In a similar manner (although not shown), when a force is applied to the left side of the body 104, the flexure 216 bends outward to the left, thus engaging and subsequently moving an actuator element of the first switch 212. This particular arrangement may be widely varied. For example, it may be used as shown to produce a mouse with two button functionality, or it may be used in combination to produce more than two button functionalities.

Moreover, it should be noted that sensors may be used in place of switches. Unlike switches, which provide binary data (e.g., activate and deactivate), sensors generally provide continuous data (e.g., they measure a continuous analog value). As such, they may produce uniform force and travel profiles

14

with respect to the clicking actions. Furthermore, they may be used to calibrate out manufacturing discrepancies.

FIG. 12 is side view, in cross section, of the mouse 100 (taken along sectional line 10-10' in FIG. 8), in accordance with an alternate embodiment of the invention. In this embodiment, a switch 220 and a tilt sensor 222 are used to produce signals associated with when the button zones A, B and C are actuated. The switch 220 is configured to activate or deactivate the clicking actions, and the tilt sensor 222 is configured to measure the degree of tilt of the body 104 so as to determine a right, middle or left clicking action. As shown, the tilt sensor 222 includes a light emitter 224 and a plurality of light detectors 226. The light emitter 224 is configured to shine a light beam 228 incident on a reflective surface 230 of the body 104. The light detectors 226 are configured to measure the light intensity of the light 232 that is reflected off of the reflective surface 230. The tilt sensor 222 may be widely varied. In the illustrated embodiment, the tilt sensor 222 includes a pair of light detectors 226A and 226B that are positioned on opposite sides of the light emitter 224. The tilt angle may be determined by the intensity of light that is reflected on each of the detectors 224. In simple terms, if the light intensity on detector 226A is greater than on detector 226B, then the body 104 is tilted to the right, and if the light intensity on detector 226A is less than on detector 226B, then the body 104 is tilted to the left. In most cases, the detectors produce signals that report voltage based on the amount of tilt.

It should be noted that a pair of detectors is not a limitation and that one or more detectors may be used. In one implementation, two pairs of detectors, which are positioned orthogonal to each other are used to determine tilt in multiple directions.

FIG. 13A is a side view, in cross section, of the mouse 100 (taken along sectional line 10-10' in FIG. 8), in accordance with an alternate embodiment of the invention. In this embodiment, a switch 234 and a tilt sensor 236 are used to produce signals associated with when the button zones A, B and C are actuated. The switch 234 is configured to activate or deactivate the clicking actions, and the tilt sensor 236 is configured to measure the degree of tilt of the body 104 so as to determine a right, middle or left clicking action. As shown, the tilt sensor 236 includes a light emitter 238, a collimator 240 and a position sensitive detector array 242. The light emitter 238 (e.g., I-R emitter diode) is configured to shine a light beam 244 incident on the position sensitive detector array 242. The collimator 240 is configured to help focus the light 244 on the detector array 242. The position sensitive detector array 242 is configured to measure the position of the light 244 incident on the detector array 242. In simple terms, if the light 244 is detected on the left detectors of the detector array 242, then the body 104 is tilted to the right (as shown in FIG. 13C), and if the light 244 is detected on the right detectors of the detector array 242, then the body 104 is tilted to the left (as shown by FIG. 13B).

FIG. 14 is a broken away perspective diagram of a unibody mouse 250, in accordance with one embodiment of the present invention. By way of example, the unibody mouse may correspond to the mouse shown in FIG. 8. The mouse 250 includes a body 252 and a base 254. The base 254 and body 252 are configured to enclose a plurality of electrical components 256. The electrical components 256, which are supported by the base 254, include at least a printed circuit board 258 having a plurality of switches 260 attached thereto. The base 254 and body 252 are also configured to provide a clicking action. Broadly, the clicking action is provided by a pivot flexure joint that allows the body to move in multiple

directions (e.g. multiple DOF). For example, the body may be capable of tilting to the left-front, right-front or middle-front of the mouse.

More specifically, the body **252** is pivotally coupled to the base **254** via a pair of pivot pins **264**, which extend from the body **252** and which are located towards the rear of the body **252**. The pivot pins **264** are configured to be coupled to a pair of flexure supports **266** which are flexibly attached to the base **254**, and which are located towards the rear of the base **254**. The pivot pins **264** are adapted to be inserted into openings **268** in the flexure support **266** thereby allowing the body **252** to pivot relative to the base **254**. The flexure support **266** is formed from a bendable or deformable material that allows the body **252** to move in multiple directions (e.g., side to side). For example, the flexure support may be formed from plastic, metal and the like. The flexure support may be mounted on the base **254** or it may be part of the base **254**. In the illustrated embodiment, the flexure support **266** and base **254** are integrated into one unit (e.g., the flexure support is formed into the base).

As should be appreciated, the pivot allows the body **252** to swing between an unclicked position, placing the body **252** in an upright position, and a front clicked position, tilting the body **252** towards the front of the mouse **250**. In addition, the flexure allows the body to swing between an unclicked position, placing the body **252** in an upright position, and a left or right clicked position, tilting the body **252** to the right and left sides of the mouse **250**. In one embodiment, a spring mechanism is used to bias the body **252** in a direction away from the base **254**, i.e., in the un-clicked positions. By way of example, the spring mechanism may be part of the switches **260**, i.e., the actuators may be biased in the upright position, or it may be a separate spring pad connected to the base **254**. In the illustrated embodiment, the spring mechanism is part of the middle switch **260C**, and thus the actuator **261** of the switch **260C** is configured to push against an inner surface of the body **254** so as to bias the body in the unclicked position.

In the right clicked position (e.g., when a downward force is applied to the right front side of the body **252**), the body **252** is configured to engage the right switch **260A**. That is, during the clicking action, a bottom portion of the body is pushed against the actuator **263A** of the sensor **260A** thereby activating the switch **260A**. In the left clicked position (e.g., when a downward force is applied to the left front side of the body **252**), the body **252** is configured to engage the left sensor **260B**. That is, during the clicking action, a bottom portion of the body is pushed against the actuator **263B** of the switch **260B** thereby activating the sensor **263B**. In the middle clicked position (e.g., when a downward force is applied to the middle front side of the body **252**), the body **252** is configured to engage the switch **260C**. That is, during the clicking action, a bottom portion of the body is pushed against the actuator **261** of the switch **260C** thereby activating the switch **260C**. Although FIG. **14** is directed towards switches, it should be noted that sensors may also be used.

When the switches are activated, one or more signals are provided to a host device such as a computer. In one implementation, the signals are first processed by a processor chip **270**, which is positioned on the PCB **258**. The processor chip **270** is typically configured to turn the signals into data, which can be used by a computer. The data signals may be sent through a cable **272** that is connected to the processor chip **270**. One end of the cable **272** typically includes a connector **278** for temporarily coupling the mouse **250** to the computer. By way of example, the connector **278** may be a PS/2 connector, a serial connector, a USB connector and the like.

Although the switches are configured to report three states: right click, left click, and middle click, the mouse itself may be configured to provide one or more button functions. For example, the mouse may be configured to provide a single button function, two button functions, three button functions and the like. In the case of single button functionality, the three states may all correspond to the same button function. That is, no matter which click is used: right click, left click and middle click, the mouse implements a single button function. In the case of dual button functionality, a portion of the three states may correspond to the same button function and a portion may correspond to a different button function. For example, a right click and a middle click may correspond to a first button function, and the left click may correspond to a second button function. In addition, a left click and a middle click may correspond to a first button function, and the right click may correspond to a second button function. Moreover, a right click and a left click may correspond to a first button function, and the middle click may correspond to a second button function. In the case of three button functionality, the three states may correspond to different button functions. For example, a right click may correspond to a first button function, a middle click may correspond to a second button function and a left click may correspond to a third button function.

In one embodiment, the signal interpretation is implemented at the mouse. In another embodiment, the signal interpretation is implemented by the host device to which the mouse is connected. In this embodiment, the signal interpretation may be implemented via software, as for example, the operating system (OS) of the host device using the mouse. For example, with regards to a two button mouse, the OS may decide whether the middle click should be associated with a left or right click.

The manner in which the host device (computer) interprets the signals may be widely varied. In one embodiment, the host device is configured to interpret the signals so as to produce a single button mouse. For example, the host device may be configured to provide a single button function when any of the three states are activated (together or separately). In another embodiment, the host device is configured to interpret the signals so as to produce a dual button mouse. For example, the host device may be configured to provide two button functions when specific states are activated (together or separately). In yet another embodiment, the host device is configured to interpret the signals so as to produce a three button mouse. For example, the host device may be configured to provide three button functions when specific states are activated (separately).

In one implementation, the signal interpretation is programmable so as to allow a user to control the type and number of button functions implemented by the mouse. For example, if a user wants a two button mouse, the middle clicking actions can be reported as either right or left clicks. This allows the mouse clicking to be slightly customized by the user so as to better match the desires of the user. For example, a right handed user may want to configure the mouse differently than a left handed user. In addition, once a user increases their skills, they may want to add more functionality to the mouse. In one embodiment, a control panel may be used to allow a user to program the functionality of the mouse. For example, the control panel may include enable/disable selections, or specific configurations such as a two button mouse with right and left click selections or front and back click selections.

FIG. **15** is a flow diagram of mouse processing **300**, in accordance with one embodiment of the invention. The mouse processing **300** is generally performed by a computer

system (or computer) to provide the computer system with one or more button functionalities. In one embodiment, the computer system corresponds to a general purpose computer such as an IBM compatible computer or Apple computers.

The mouse processing **300** generally begins at block **302** 5 where inputs from a mouse are monitored. Here, one or more states associated with the mouse can be monitored. By way of example, the states being monitored can include clicking actions such as right click, left click and middle click. After block **302**, the process proceeds to block **304** where status 10 information associated with the states are obtained from the monitoring. By way of example, the status information may correspond to which of the states are activated (e.g., on or off).

After block **304**, the process proceeds to block **306** where 15 button functions of the mouse are determined. The button functionalities are generally based on the status information and predetermined configuration information. In one embodiment, the predetermined configuration information identifies a type and nature of button function that is to be provided for a specific status information. By way of 20 example, an on screen action such as selecting an item on the screen may be identified when a left click status is activated, and a right and middle click status is not activated. In one embodiment, the predetermined configuration information is stored in memory. Thus, the computer consults the informa- 25 tion held in memory in order to determine the on-screen action for a specific clicking action. The predetermined configuration information stored in the memory may be accessed by a user through a mouse control menu, which may be viewed on a display screen as part of a GUI interface. The 30 mouse control menu may include control settings pertaining to one or more on screen actions. In fact, the mouse control menu may serve as a control panel for reviewing and/or customizing the mouse control settings, i.e., the user may quickly and conveniently review the mouse control settings 35 and make changes thereto. Once the user saves the changes, the modified mouse control settings will be employed (e.g., as predetermined configuration information) to handle future events transmitted and/or received through the computer.

After the button functions have been determined, the pro- 40 cess proceeds to block **310** where appropriate button functions are used to perform the on screen action. For example, the on screen actions may select an item on the screen, open a file or document, execute instructions, start a program, view a list of commands (or system properties), or the like. There- 45 after, the process can proceed to back to block **302** where mouse inputs are monitored.

While this invention has been described in terms of several preferred embodiments, there are alterations, permutations, and equivalents, which fall within the scope of this invention. 50 For example, the mouse may include an adjustable tensioner to stiffen the ease of the clicking action, i.e., the tension may be lowered to accommodate smaller and lighter hands and increased to accommodate larger and heavier hands. It should also be noted that there are many alternative ways of imple- 55 menting the methods and apparatuses of the present invention. It is therefore intended that the following appended claims be interpreted as including all such alterations, permutations, and equivalents as fall within the true spirit and scope of the present invention.

What is claimed is:

1. A method of sending signals corresponding to multiple button functionalities from a unibody mouse to an electronic system having a single movable housing component that cooperates with and is movably coupled with a base housing 65 component that supports the unibody mouse on a surface, comprising:

associating the multiple button functionalities with specific portions of the single movable housing component;
activating each of the multiple button functionalities by moving the single movable housing component to different positions relative to the base housing component wherein the single movable housing component has at least two degrees of freedom relative to the base housing component;
generating a clicking action by moving the movable housing component relative to the base housing component along at least one of the at least two degrees of freedom; and
sending a signal to the electronic system based upon the clicking action.

2. A method as recited in claim **1**, wherein the clicking action implements a function selected from a group comprising: a single click function, a double click function, and/or a dragging and dropping function.

3. A method as recited in claim **1**, wherein the electronic system includes a display screen suitable for displaying images.

4. A method as recited in claim **3** wherein each of the multiple button functionalities corresponds to an action on a display screen.

5. A method as recited in claim **4**, wherein the single click function causes the electronic system to select a particular image on the display, and wherein the double click function causes the electronic system to open a document and/or launch a program, and wherein the dragging and dropping function generally causes the electronic system to move an item on the screen in accordance with movement of the unibody mouse in relation to the surface.

6. A method as recited in claim **1**, wherein more than two degrees of freedom are used to implement multiple clicking actions.

7. A method as recited in claim **6** wherein each of said clicking actions has a switch associated therewith that is capable of differentiating when each of said clicking actions is actuated.

8. A method as recited in claim **7** wherein each of said switches is enclosed by said housing.

9. A method as recited in claim **1** wherein said single movable housing component is coupled to the base housing component via a combination of joints selected from pivot joints, slider joints, ball and socket joints, or flexure joints, and wherein each pivot joint represents a different pivot axis.

10. A method as recited in claim **1** wherein said single movable housing component pivots relative to said base housing component about a first axis and about a second axis.

11. A method as recited in claim **10** wherein said first axis is orthogonal to said second axis.

12. A method as recited in claim **1**, wherein the electronic system is a computer.

13. A method of configuring a multi-function mouse having a single movable housing component being movably coupled to an associated base housing component that supports the multi-function mouse on a surface, the method comprising:

assigning a number of distinct button zones to the single movable housing component;

generating a signal from an assigned button zone by moving the single movable housing component relative to the base housing component along at least one of at least two degrees of freedom available to the single movable housing component relative to the base housing compo-

19

ment, thereby actuating an associated movement indicator configured to sense a movement of the associated assigned button zones;

interpreting the signal received from the associated assigned button zone as a corresponding button function; and

performing the button function corresponding to the signal received from the mouse.

14. A method as recited in claim 13, wherein when the multi-function mouse is user programmable, then the interpreting the signal received from each assigned button zone is updated to correspond to a user provided button function.

15. A method as recited in claim 13, further comprising: connecting the multi-function mouse to a computer having a display screen arranged to display an image and a processor unit operatively coupled to the display screen, wherein the processor unit receives and interprets the signal received from the multi-function mouse.

16. A method as recited in claim 15, wherein the button function is selected from a group comprising: a single click function, a double click function, and/or a dragging and dropping function.

17. A method as recited in claim 16, wherein the single click function causes the processor to select a particular image on the display, and wherein the double click function causes the processor to open a document and/or launch a program, and wherein the dragging and dropping function generally causes the processor to move an item on the screen in accordance with movement of the multi-function mouse in relation to the surface.

18. A method as recited in claim 13 wherein said single movable housing component is coupled to the base housing component via a combination of joints selected from pivot joints, slider joints, ball and socket joints, or flexure joints, and wherein each pivot joint represents a different pivot axis.

19. A method as recited in claim 13 wherein said single movable housing component pivots relative to said base housing component about a first axis and about a second axis.

20. A method as recited in claim 19 wherein said first axis is orthogonal to said second axis.

21. Computer program product executable by a processor for configuring a multi-function mouse having a single movable housing component being movably coupled to an associated base housing component that supports the multi-function mouse on a surface, comprising:

computer code for assigning a number of distinct button zones to the single movable housing component;

computer code for generating a signal from an assigned button zone by moving the single movable housing component relative to the base housing component along at least one of at least two degrees of freedom available to the single movable housing component relative to the base housing component, thereby actuating an associated movement indicator configured to sense a movement of the associated assigned button zones;

computer code for interpreting the signal received from the assigned button zone as a corresponding button function;

computer code for performing the button function corresponding to the signal received from the mouse; and

computer readable medium for storing the computer code.

22. Computer program product as recited in claim 21, wherein when the multi-function mouse is user programmable, then the interpreting the signal received from each assigned button zone is updated to correspond to a user provided button function.

20

23. Computer program product as recited in claim 21, further comprising:

computer code for connecting the multi-function mouse to a computer having a display screen arranged to display an image and a processor unit operatively coupled to the display screen, wherein the processor unit receives and interprets the signal received from the multi-function mouse.

24. Computer program product as recited in claim 23, wherein the button function is selected from a group comprising: a single click function, a double click function, and/or a dragging and dropping function.

25. Computer program product executable by a processor in an electronic system, comprising

computer code for assigning a number of distinct button zones to a single movable housing component of a user input device communicatively coupled with the electronic system, the single movable housing component being movably coupled to an associated base housing component that supports the user input device on a surface, the single movable housing component being capable of movement along at least two degrees of freedom relative to the base housing component;

computer code for associating a button function with each assigned button zone;

computer code for interpreting a signal received from the user input device, the signal being produced in the user input device and transmitted to the electronic system as a result of actuating a button zone, the button zone being actuated as a result of moving the single movable housing component relative to the base housing component to actuate an associated movement indicator configured to sense a movement of the associated button zone, wherein interpreting the signal involves at least determining which button zone was actuated;

computer code for implementing a specific button function corresponding to the associated actuated button zone, the button function corresponding to an action on a display; and

computer readable medium for storing the computer code.

26. Computer program product as recited in claim 25, wherein the button function is one selected from a group comprising: a single click function, a double click function, and/or a dragging and dropping function.

27. Computer program product as recited in claim 26, wherein the single click function causes the electronic system to select a particular image on the display, and wherein the double click function causes the electronic system to open a document and/or launch a program, and wherein the dragging and dropping function generally causes the electronic system to move an item on the screen in accordance with movement of the user input device in relation to the surface.

28. A system, comprising:

a unibody user input device having multiple assigned button zones in a single movable housing component of the user input device, wherein each button zone has an associated button functionality and all of said multiple button functionalities are incorporated into the single movable housing component, the single movable housing component being movably coupled to a base housing component that supports the mouse along a surface, wherein the movable housing component is capable of movement along at least two degrees of freedom relative to the base housing component, wherein actuation of a single button zone is achieved by moving the movable housing component relative to the base housing component to

21

actuate an associated movement indicator configured to sense a movement of the associated button zone;
a display; and
a processor communicatively coupled with the mouse, the processor configured to interpret a signal received from the user input device, the signal being produced in the user input device as a result of the actuation of a button

5

22

zone, wherein the interpretation of the signal involves at least the determination of which button zone was actuated, the processor being further configured to implement a specific button function corresponding to the associated actuated button zone, the button function corresponding to an action on the display.

* * * * *