



US007530908B2

(12) **United States Patent**
Boehm et al.

(10) **Patent No.:** **US 7,530,908 B2**
(45) **Date of Patent:** ***May 12, 2009**

(54) **MULTI-LAYER GOLF BALL HAVING VELOCITY GRADIENT FROM FASTER CENTER TO SLOWER COVER**

(75) Inventors: **Herbert C. Boehm**, Norwell, MA (US); **Michael J. Sullivan**, Barrington, RI (US); **Steven Aoyama**, Marion, MA (US); **David A. Bulpett**, Boston, MA (US); **Derek A. Ladd**, Acushnet, MA (US)

(73) Assignee: **Acushnet Company**, Fairhaven, MA (US)

(*) Notice: Subject to any disclaimer, the term of this patent is extended or adjusted under 35 U.S.C. 154(b) by 0 days.

This patent is subject to a terminal disclaimer.

(21) Appl. No.: **11/872,777**

(22) Filed: **Oct. 16, 2007**

(65) **Prior Publication Data**

US 2008/0171617 A1 Jul. 17, 2008

Related U.S. Application Data

(63) Continuation of application No. 11/061,260, filed on Feb. 18, 2005, now Pat. No. 7,300,364, which is a continuation-in-part of application No. 10/773,906, filed on Feb. 6, 2004, now Pat. No. 7,255,656.

(51) **Int. Cl.**
A63B 37/06 (2006.01)

(52) **U.S. Cl.** **473/376**

(58) **Field of Classification Search** **473/376,**
473/374, 373, 368, 367

See application file for complete search history.

(56) **References Cited**

U.S. PATENT DOCUMENTS

4,508,309 A	4/1985	Brown
4,625,964 A	12/1986	Yamada
4,863,167 A	9/1989	Matsuki et al.
5,048,126 A	9/1991	McLaughlin
5,104,126 A	4/1992	Gentiluomo
5,184,828 A	2/1993	Kim et al.
5,273,286 A	12/1993	Sun
5,334,673 A	8/1994	Wu
5,482,285 A	1/1996	Yabuki et al.
5,490,674 A	2/1996	Hamada et al.
5,743,816 A	4/1998	Ohsumi et al.
5,772,531 A	6/1998	Ohsumi et al.
5,824,746 A	10/1998	Harris et al.
5,908,358 A	6/1999	Wu
5,919,100 A	7/1999	Boehm et al.
5,929,189 A	7/1999	Ichikawa et al.
5,971,870 A	10/1999	Sullivan et al.
6,025,442 A	2/2000	Harris et al.
6,056,842 A	5/2000	Dalton et al.
6,117,024 A	9/2000	Dewanjee
6,117,025 A	9/2000	Sullivan et al.
6,120,393 A	9/2000	Sullivan et al.
6,142,887 A	11/2000	Sullivan et al.

(Continued)

Primary Examiner—Raeann Trimiew
(74) *Attorney, Agent, or Firm*—Troy R. Lester

(57) **ABSTRACT**

The present invention is directed to multi-layer golf balls having a center, a cover layer, and at least one intermediate layer between the core and the cover layer. The core, the at least one intermediate layer and the cover are constructed to have different initial velocities and COR such that the gradient of the initial velocities and COR progress from a faster center to a slower cover.

11 Claims, 1 Drawing Sheet

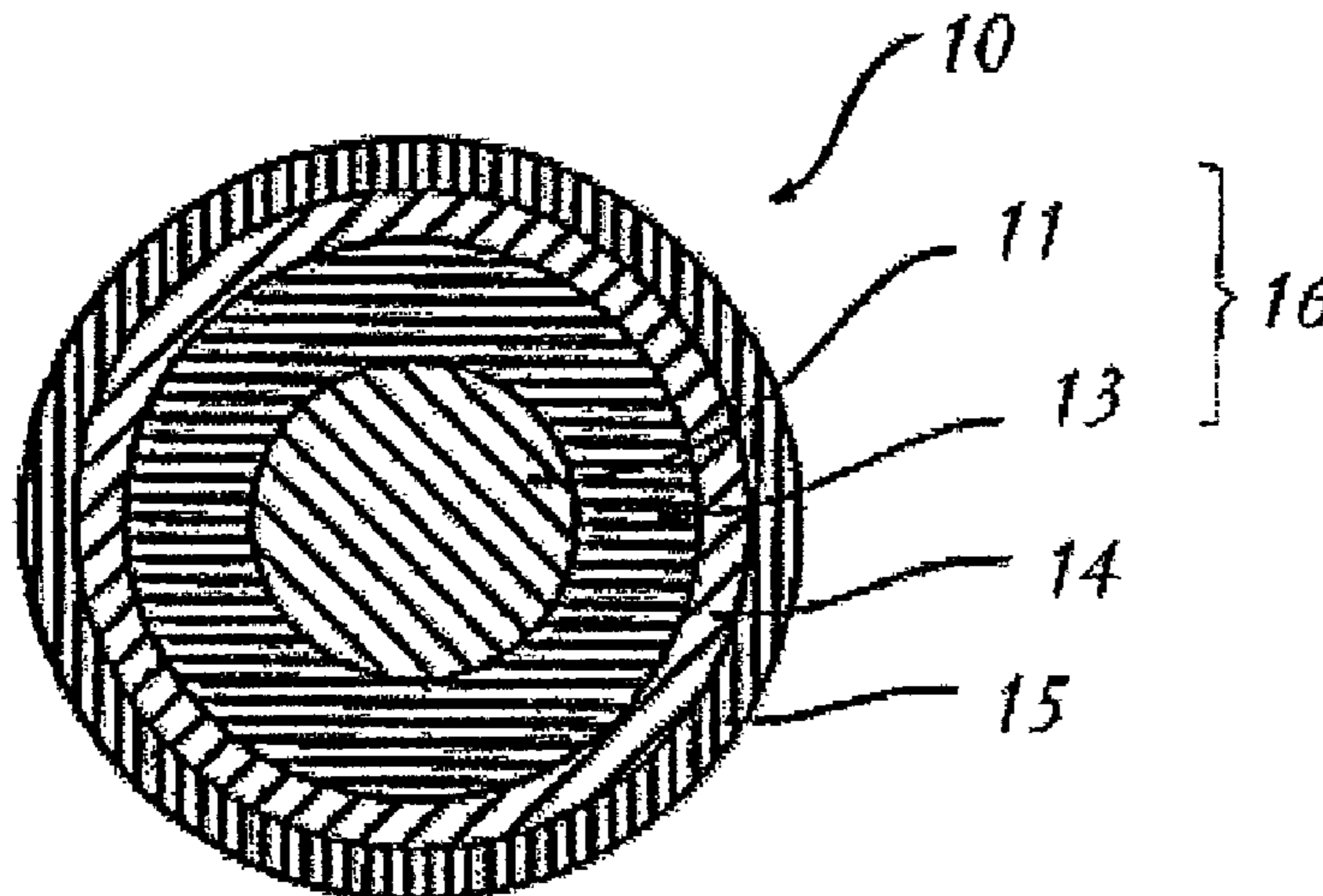

US 7,530,908 B2

Page 2

U.S. PATENT DOCUMENTS

6,210,294	B1	4/2001	Wu	6,390,935	B1	5/2002	Sugimoto	
6,302,808	B1	10/2001	Dalton et al.	6,855,076	B2	2/2005	Matroni et al.	
6,309,313	B1	10/2001	Peter	7,300,364	B2 *	11/2007	Boehm et al. 473/376
6,315,682	B1	11/2001	Iwami et al.	2002/0019268	A1	2/2002	Tsunoda et al.	
6,390,396	B1	5/2002	Takano et al.	2002/0147057	A1	10/2002	Binette et al.	

* cited by examiner

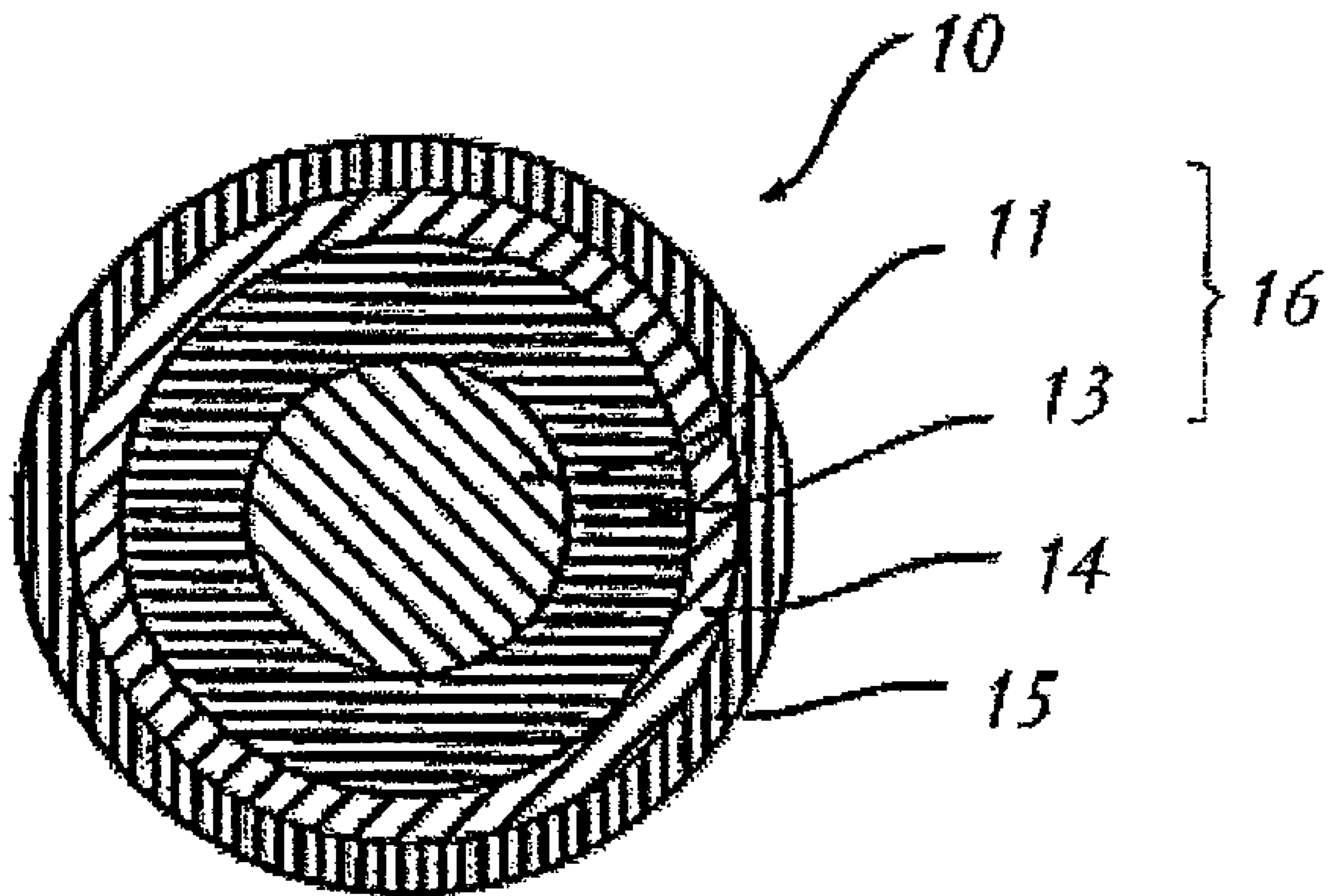

FIG. 1

1

**MULTI-LAYER GOLF BALL HAVING
VELOCITY GRADIENT FROM FASTER
CENTER TO SLOWER COVER**

CROSS REFERENCE TO RELATED
APPLICATIONS

This application is a continuation of U.S. application Ser. No. 11/061,260, filed on Feb. 18, 2005, now U.S. Pat. No. 7,300,364 which is a continuation-in-part of U.S. application Ser. No. 10/773,906, filed Feb. 6, 2004, which issued as U.S. Pat. No. 7,255,656, both of which are incorporated by reference in their entirety.

FIELD OF THE INVENTION

This invention is related to multi-layer golf balls having a COR gradient that progresses from a faster center to a slower cover.

BACKGROUND OF THE INVENTION

Two-layer golf balls are typically made with a single solid core encased by a cover. These balls are generally most popular among recreational golfers, because they are durable and provide maximum distance. Typically, the solid core is made of polybutadiene cross-linked with zinc diacrylate and/or similar crosslinking agents. The cover material is a tough, cut-proof blend of one or more materials known as ionomers such as SURLYN® sold commercially by DuPont, or IOTEK® sold commercially by Exxon.

Multi-layer golf balls may have multiple core layers, multiple intermediate layers, and/or multiple cover layers. They tend to overcome some of the undesirable features of conventional two-layer balls, such as hard feel and less control, while maintaining the positive attributes, such as increased initial velocity and distance. Further, it is desirable that multi-layer balls have a "click and feel," similar to wound balls.

Additionally, the spin rates of golf balls affect the overall control of the balls in accordance to the skill level of the players. Low spin rates provide improved distance, but make golf balls difficult to stop on shorter shots, such as approach shots to greens. High spin rates allow more skilled players to maximize control of the golf ball, but adversely affect driving distance. To strike a balance between the spin rates and the playing characteristics of golf balls, additional layers, such as intermediate layers, outer core layers and inner cover layers are added to solid golf balls to improve the playing characteristics of the ball.

The patent literature discloses a number of multi-layer golf balls. U.S. patent application Ser. No. 10/773,906, which is commonly owned and incorporated herein by reference in its entirety, is directed to an improved multi-layer golf ball displaying certain spin profile. The ball has a generally rigid, thermosetting polybutadiene outer core surrounding a relatively soft, low compression inner core. The inner core has a hardness that is less than the hardness of the outer core, and a specific gravity that is less than or equal to the specific gravity of the outer core. The inner core and outer core are formulated to provide a combined overall core compression of greater than about 50.

U.S. patent application Ser. No. 09/853,252, which is commonly owned and incorporated by reference in its entirety, is directed to golf balls having a cover comprising three or more layers: an inner cover layer, an outer cover layer, and an intermediate cover layer. The outer cover layer comprises a composition formed of a reactive liquid material, and the

2

combination of the thickness of the cover layers is about 0.125 inch. Golf balls prepared accordingly can exhibit substantially the same or higher coefficient of restitution ("COR"), with a decrease in compression or flexural modulus, compared to golf balls of conventional construction. The resultant golf balls typically have a COR of greater than about 0.7 and an Atti compression of at least about 40.

U.S. patent application Ser. No. 10/279,506, which is also commonly owned, and incorporated by reference in its entirety, is directed to a golf ball comprising an inner core, an outer core, and a cover. At least a layer of the golf ball is made from a low compression, high COR material, and is being supported by a low deformation, high compression layer. The resulting golf ball has high COR at high and low impact speeds and low compression for controlled greenside play.

U.S. Pat. No. 6,645,089 to Tsuoda et al. and U.S. Pub. Pat. App. Nos. 2002/0019268 and 2002/0042308 by Tsunoda, et al. are directed to a golf ball comprising a 6-layer core. The modulus of elasticity of each layer of the core progresses from lower to higher modulus in the direction from the center to the outermost core layer.

U.S. Pat. No. 6,419,595 to Maruko et al. is directed to a 5-piece golf ball comprising a single core and 4 cover layers. The innermost cover layer has less than 60 Shore D hardness, the next cover layer has greater than 45 Shore D hardness, and the outermost cover layer is harder than the third cover layer.

However, there remains a need for multi-layer golf balls having velocity gradient that progresses from a faster center to a slower cover to match the balls to the players' swing speed.

SUMMARY OF THE INVENTION

This invention is directed to a multi-layer golf ball comprising a core, a cover layer, and at least one intermediate layer between the core and the cover layer. The ball may have an unlimited number of intermediate layers but typically will have from 1 to about 8 intermediate layers, and each layer of the ball has a different coefficient of restitution value. The coefficient of restitution gradient from the center to the outermost layer is from high to low, or the initial velocity gradient from the center to the cover layer is from fast to slow.

For the purposes of this patent, the center is the innermost core layer and any outer core layer will be considered an intermediate layer.

According to the present invention, the center of the multi-layer golf ball has a COR value of at least 0.815, preferably at least 0.825, and more preferably at least 0.830. The center and the first intermediate layer have a combined COR value of at least 0.810, preferably, at least 0.820, and more preferably at least 0.825. The center, the first intermediate layer, and the second intermediate layer have a combined COR value of at least 0.800, preferably at least 0.810, and more preferably at least 0.815.

In another aspect of the invention, for golf balls having four or more layers the combined COR of a subassembly is 0.003 greater than the combined COR of that subassembly plus the next outer layer, preferably 0.005, and more preferably 0.010. For golf balls having three layers, the combined COR of a subassembly is 0.004 greater than the combined COR of that subassembly plus the next outer layer, preferably 0.006, and more preferably 0.010.

In a different aspect of the invention, the change in COR is normalized as the change in COR from one subassembly to the next larger subassembly in the radial direction per the thickness of the next larger assembly in the radial direction. The normalized combined COR for golf balls with any num-

ber of layers of a subassembly is 0.00015 per thousandth of an inch greater than the normalized combined COR of that subassembly plus the next outer layer, preferably 0.00025 per thousandth, and more preferably 0.00035 per thousandth.

In another aspect of the invention, the material of each individual layer taken alone or independent of the subassembly has a coefficient of restitution that is lower than or the same as the coefficient of restitution of the layer beneath it.

The center of the multi-layer golf ball may comprise any thermoplastic and/or thermosetting polymer(s) including, but not limited to, a highly neutralized polymer formed from a reaction between acid groups on a polymer, a suitable source of cation, and an organic acid or the corresponding salt, and the extent of neutralization is at least 80%, preferably at least 90%, and more preferably 100%. Suitable source of cation is selected from magnesium, sodium, zinc, lithium, potassium, and calcium; the organic acid or the corresponding salt is selected from oleic acid, salt of oleic acid, stearic acid, salt of stearic acid, behenic acid, salt of behenic acid or a combination thereof, metallocene or other single site catalyzed polymers, styrenic block copolymers, ionomers, thermoplastic elastomers, fluoropolymers, styrene butadiene rubber, natural or synthetic polyisoprene, butyl or halobutyl rubber, or blends thereof.

Alternatively, the core may also be is a product of a reaction mixture comprising a polybutadiene, a cis-to-trans catalyst, a free radical source, a crosslinking agent, and a filler.

The intermediate layer(s) may comprise a polybutadiene, a polyurethane, a polyurea, a highly neutralized polymer, a silicone, a polyolefin, a polyamide, a polyester, a polyether amide, a polyester amide, or a blend thereof.

The cover layer may comprise a polyurethane, a polyurea, a highly neutralized polymer, a polybutadiene, a polyolefin, or a blend thereof. The cover or core layer may also be a product of a reaction mixture comprising a diene rubber such as polybutadiene, a peroxide initiator, an unsaturated crosslinking agent such as zinc diacrylate, zinc methacrylate, or zinc dimethacrylate optionally a cis-to-trans catalyst, and a filler.

BRIEF DESCRIPTION OF THE DRAWING

FIG. 1 illustrates a multi-layer golf ball with a velocity gradient that changes from a faster core to a slower cover layer.

DETAILED DESCRIPTION OF THE INVENTION

The present invention is directed to multi-layer golf balls having a center, a cover layer, and at least one intermediate layer between the center and the cover layer. The multi-layer golf ball preferably has a total of 3 to 10 layers, and more preferably 3 to 6 layers. There can be an unlimited number of intermediate layers but typically from 1 to 8 intermediate layers, more preferably 2 to 4. As used herein, a golf ball subassembly comprises at least the center and may further comprise one or more intermediate layers and the outer cover layer. A subassembly of any layer refers to said layer plus all the inner layers that are underneath said layer. The center, the intermediate layers and the outer cover layer are constructed to have different COR's, and each ball subassembly is constructed such that the gradients of COR's progress from a faster center to a slower cover.

Referring to FIG. 1, the multi-layer golf ball (10) comprises a core or center (11), a cover layer (15) and intermediate layers (13, 14). For the purpose of illustration, a first intermediate layer (13) and a second intermediate layer (14)

are shown. The first subassembly is the center (11). The second subassembly (16) is the combination of the center (11) and the first intermediate layer (13), and so on. Intermediate layers (14) can be mantle layers, outer core layers, or inner cover layers.

The coefficient of restitution ("COR") is a measurement of the collision between the ball and a relatively larger mass. One conventional technique for measuring COR uses a golf ball or golf ball subassembly, air cannon, and a stationary vertical steel plate. The steel plate provides an impact surface weighing about 100 pounds or about 45 kilograms. A pair of ballistic light screens are spaced apart and located between the air cannon and the steel plate. The ball is fired from the air cannon toward the steel plate over a range of test velocities from 50 ft/sec to 180 ft/sec. Unless noted otherwise, all COR data presented in this application are measured using a speed of 125 ft/sec. As the ball travels toward the steel plate, it activates each light screen so that the time at each light screen is measured. This provides an incoming time period proportional to the ball's incoming velocity. The ball impacts the steel plate and rebounds through the light screens, which again measure the time period required to transit between the light screens. This provides an outgoing transit time period proportional to the ball's outgoing velocity. The COR can be calculated by the ratio of the outgoing transit time period to the incoming transit time period.

As discussed above, the initial velocity of each subassembly is greater than, or substantially equal to, the next larger subassembly toward the cover. The center has a COR (COR_C) that is highest among all the subassemblies. The center and the first intermediate layer have a $COR(COR_{C1})$ that is slower than, or substantially equal to, the $COR(COR_C)$ of the core. Likewise, the center, and the first and second intermediate layers have a $COR(COR_{C2})$ that is slower than, or substantially equal to, $COR(COR_{C1})$ of the center and the first intermediate layer.

At 125 ft/sec, the COR of the center (COR_C) is at least 0.815, preferably at least 0.825, and more preferably at least 0.830. The combined $COR(COR_{C1})$ of the center and the first intermediate layer is less than the $COR(COR_C)$ of the center. COR_{C1} is at least 0.810, preferably at least 0.820 and more preferably at least 0.825. The combined $COR(COR_{C2})$ of the center, and the first and second intermediate layers is less than the combined $COR(COR_{C1})$ of the center and the first intermediate layer. COR_{C2} is at least 0.800, preferably at least 0.810, and more preferably at least 0.815. Alternatively for golf balls with four or more layers, the COR of each subassembly is at least about 0.003 greater than the next larger subassembly toward the cover, preferably at least about 0.005 greater, and more preferably at least about 0.010 greater. For golf balls with three layers, the COR of each assembly is about 0.004 greater than the next larger subassembly toward the cover, preferably at least about 0.006 greater and more preferably at least about 0.010 greater.

Consequently, the multi-layer golf ball has an initial velocity and COR gradients that progress from a faster center to a slower cover. The initial velocity and COR gradients from the center to the cover can be expressed by:

$$V_C \geq V_{C1} \geq V_{C2} \geq V_{C3} \geq V_{C4} \geq V_{CS} \dots;$$

When the ball has four or more layers, the COR gradient can be expressed by

$$COR_C \geq COR_{C1} + 0.003; COR_{C1} \geq COR_{C2} + 0.003; \\ COR_{C2} \geq COR_{C3} + 0.003 \dots$$

5

When the ball has three layers, the COR gradient can be expressed by

$$\begin{aligned} COR_C &\geq COR_{C1} + 0.004; \quad COR_{C1} \geq COR_{C2} + 0.004; \\ COR_{C2} &\geq COR_{C3} + 0.004. \end{aligned}$$

In another embodiment, the velocity gradient is normalized per layer thickness in the radial direction such that a “normalized COR” is defined as the change in COR from one subassembly to the next larger subassembly in the radial direction divided by the thickness of the next subassembly, wherein the value reported is defined as the COR change per thousandth of an inch. For golf balls in accordance to the present invention, the normalized COR is at least 0.00015, preferably 0.00025, and more preferably 0.00035.

In one embodiment, a golf ball so constructed has a COR of less than about 0.820 and an initial velocity conforming to current USGA limits.

In a different embodiment, the material of each individual layer, taken by itself, has a coefficient of restitution less than or equal to the material of the layer beneath it. Coefficient of restitution of the material may be defined as the COR of a sphere between 0.25 inch to 1.68 inch, preferably between 1.00 inch to 1.62 and more preferably between 1.30 inch to 1.60 inch molded of that material and that sphere is tested for COR as discussed above. The COR of the material can also be measured on a plaque, button, or slab of material such as bayshore resilience, tan delta via dynamic mechanical analysis. A method of measuring coefficient of restitution is described in commonly-owned U.S. patent application Ser. No. 10/914,289, which is incorporated herein by reference in its entirety. At 125 ft/sec, the coefficient of restitution of the materials according to this invention, as defined in COR values, may be in the range of about 0.100 to about 0.900, preferably about 0.400 to about 0.875, and more preferably about 0.600 to about 0.850. The COR of the material used to create a layer (center, outer core, inner or outer cover, etc.) is then “extrapolated” or otherwise standardized to the COR of standard spheres, and the same equations used for the composite subassemblies, discussed above, are used for “material COR”. For example for a four-layer ball construction solid spheres at a size of 1.500 inch are molded using the materials used for the center, outer core, inner cover, other intermediate layers and outer cover, respectively. The relationship of CORs is such that the COR of the inner core > COR of the next layer > COR of the next layer > COR of the outer cover.

In all of these embodiments, the progression of compression of each layer is not limited to a particular trend. Compression is an important factor in golf ball design, e.g. the compression of the core determines the ball’s spin rate off the driver and the feel. Several different methods have been used to measure compression, including Atti compression, Riehle compression, load/deflection measurements at a variety of fixed loads and offsets, and the effective modulus. See Jeff Dalton, *Compression by Any Other Name, Science and Golf IV, Proceedings of the World Scientific Congress of Golf* (Eric Thain ed., Routledge, 2002) (“J. Dalton”). The conversions from the Atti compression to Riehle (cores), Riehle (balls), 100 kg deflection, 130-10 kg deflection or effective modulus can be carried out according to the formulas given in J. Dalton. Likewise, the golf balls of this invention are not constrained to a particular progression of flexural modulus, hardness or compression. Coating or paint layers on the balls’ dimpled surface are not considered as layers of the constructions discussed herein. Nor are “adhesive layers” such as those disclosed in U.S. Pat. Nos. 6,746,345; 6,736,737;

6

6,723,008; 6,702,695 and 6,652,392. Generally any layer less than or equal to 0.002 is not considered a piece or layer of the constructions herein.

The center may also comprise thermosetting or thermoplastic materials such as polyurethane, polyurea, partially or fully neutralized ionomers, thermosetting polydiene rubber such as polybutadiene, polyisoprene, ethylene propylene diene monomer rubber, ethylene propylene rubber, natural rubber, balata, butyl rubber, halobutyl rubber, styrene butadiene rubber or any styrenic block copolymer such as styrene ethylene butadiene styrene rubber, etc., metallocene or other single site catalyzed polyolefin, polyurethane copolymers, e.g. with silicone, as long as the material meets the COR criteria described above.

In addition to the materials discussed above, compositions within the scope of the present invention can incorporate one or more polymers. Examples of suitable additional polymers for use in the present invention include, but are not limited to, the following: thermoplastic elastomer, thermoset elastomer, synthetic rubber, thermoplastic vulcanizate, copolymeric ionomer, terpolymeric ionomer, polycarbonate, polyolefin, polyamide, copolymeric polyamide, polyesters, polyvinyl alcohols, acrylonitrile-butadiene-styrene copolymers, polyarylate, polyacrylate, polyphenylene ether, impact-modified polyphenylene ether, high impact polystyrene, diallyl phthalate polymer, metallocene catalyzed polymers, styrene-acrylonitrile (SAN) (including olefin-modified SAN and acrylonitrile-styrene-acrylonitrile), styrene-maleic anhydride (S/MA) polymer, styrenic copolymer, functionalized styrenic copolymer, functionalized styrenic terpolymer, styrenic terpolymer, cellulose polymer, liquid crystal polymer (LCP), ethylene-propylene-diene terpolymer (EPDM), ethylene-vinyl acetate copolymers (EVA), ethylene-propylene copolymer, ethylene vinyl acetate, polyurea, and polysiloxane or any metallocene-catalyzed polymers of these species. Suitable polyamides for use as an additional material in compositions within the scope of the present invention also include resins obtained by: (1) polycondensation of (a) a dicarboxylic acid, such as oxalic acid, adipic acid, sebacic acid, terephthalic acid, isophthalic acid or 1,4-cyclohexanedicarboxylic acid, with (b) a diamine, such as ethylenediamine, tetramethylenediamine, pentamethylenediamine, hexamethylenediamine or decamethylenediamine, 1,4-cyclohexyldiamine or m-xylylenediamine; (2) a ring-opening polymerization of cyclic lactam, such as .epsilon.-caprolactam or .omega.-laurolactam; (3) polycondensation of an aminocarboxylic acid, such as 6-aminocaproic acid, 9-aminononanoic acid, 11-aminoundecanoic acid or 12-aminododecanoic acid; or (4) copolymerization of a cyclic lactam with a dicarboxylic acid and a diamine. Specific examples of suitable polyamides include Nylon 6, Nylon 66, Nylon 610, Nylon 11, Nylon 12, copolymerized Nylon, Nylon MXD6, and Nylon 46.

Other preferred materials suitable for use as an additional material in compositions within the scope of the present invention include polyester elastomers marketed under the tradename SKYPEL by SK Chemicals of South Korea, or diblock or triblock copolymers marketed under the tradename SEPTON by Kuraray Corporation of Kurashiki, Japan, and KRATON by Kraton Polymers Group of Companies of Chester, United Kingdom. All of the materials listed above can provide for particular enhancements to ball layers prepared within the scope of the present invention.

Ionomers also are well suited for blending into compositions within the scope of the present invention. Suitable ionomeric polymers (i.e., copolymer- or terpolymer-type ionomers) include .alpha.-olefin/unsaturated carboxylic acid copolymer-type ionomeric or terpolymer-type ionomeric res-

ins. Copolymeric ionomers are obtained by neutralizing at least a portion of the carboxylic groups in a copolymer of an .alpha.-olefin and an .alpha.,.beta.-unsaturated carboxylic acid having 3 to 8 carbon atoms, with a metal ion. Examples of suitable .alpha.-olefins include ethylene, propylene, 1-butene, and 1-hexene. Examples of suitable unsaturated carboxylic acids include acrylic, methacrylic, ethacrylic, .alpha.-chloroacrylic, crotonic, maleic, fumaric, and itaconic acid. Copolymeric ionomers include ionomers having varied acid contents and degrees of acid neutralization, neutralized by monovalent or bivalent cations discussed above.

Terpolymeric ionomers are obtained by neutralizing at least a portion of carboxylic groups in a terpolymer of an .alpha.-olefin, and an .alpha.,.beta.-unsaturated carboxylate having 2 to 22 carbon atoms with metal ion. Examples of suitable .alpha.-olefins include ethylene, propylene, 1-butene, and 1-hexene. Examples of suitable unsaturated carboxylic acids include acrylic, methacrylic, ethacrylic, .alpha.-chloroacrylic, crotonic, maleic, fumaric, and itaconic acid. Terpolymeric ionomers include ionomers having varied acid contents and degrees of acid neutralization, neutralized by monovalent or bivalent cations as discussed above. Examples of suitable ionomeric resins include those marketed under the name SURLYN® manufactured by E.I. du Pont de Nemours & Company of Wilmington, Del., and IOTEK® manufactured by Exxon Mobil Corporation of Irving, Tex.

Silicone materials also are well suited for blending into compositions within the scope of the present invention. These can be monomers, oligomers, prepolymers, or polymers, with or without additional reinforcing filler. One type of silicone material that is suitable can incorporate at least 1 alkenyl group having at least 2 carbon atoms in their molecules. Examples of these alkenyl groups include, but are not limited to, vinyl, allyl, butenyl, pentenyl, hexenyl and decenyl. The alkenyl functionality can be located at any location of the silicone structure, including one or both terminals of the structure. The remaining (i.e., non-alkenyl) silicon-bonded organic groups in this component are independently selected from hydrocarbon or halogenated hydrocarbon groups that contain no aliphatic unsaturation. Non-limiting examples of these include: alkyl groups, such as methyl, ethyl, propyl, butyl, pentyl and hexyl; cycloalkyl groups, such as cyclohexyl and cycloheptyl; aryl groups, such as phenyl, tolyl and xylyl; aralkyl groups, such as benzyl and phenethyl, and halogenated alkyl groups, such as 3,3,3-trifluoropropyl and chloromethyl. Another type of silicone material suitable for use in the present invention is one having hydrocarbon groups that lack aliphatic unsaturation. Specific examples of suitable silicones for use in making compositions of the present invention include the following: trimethylsiloxy-endblocked dimethylsiloxane-methylhexenylsiloxane copolymers; dimethylhexenylsiloxy-endblocked dimethylsiloxane-methylhexenylsiloxane copolymers; trimethylsiloxy-endblocked dimethylsiloxane-methylvinylsiloxane copolymers; trimethylsiloxy-endblocked methylphenylsiloxane-dimethylsiloxane-methylvinylsiloxane copolymers; dimethylvinylsiloxy-endblocked dimethylpolysiloxanes; dimethylvinylsiloxy-endblocked dimethylsiloxane-methylvinylsiloxane copolymers; dimethylvinylsiloxy-endblocked methylphenylpolysiloxanes; dimethylvinylsiloxy-endblocked methylphenylsiloxane-dimethylsiloxane-methylvinylsiloxane copolymers; and the copolymers listed above, in which at least one end group is dimethylhydroxysiloxy. Commercially available silicones suitable for use in compositions within the scope of the present invention

include Silastic by Dow Corning Corp. of Midland, Mich., Blensil by GE Silicones of Waterford, N.Y., and Elastosil by Wacker Silicones of Adrian, Mich.

Other types of copolymers also can be added to compositions within the scope of the present invention. Examples of copolymers comprising epoxy monomers and which are suitable for use within the scope of the present invention include styrene-butadiene-styrene block copolymers, in which the polybutadiene block contains an epoxy group, and styrene-isoprene-styrene block copolymers, in which the polyisoprene block contains epoxy. Commercially available examples of these epoxy functional copolymers include ESBS A1005, ESBS A1010, ESBS A1020, ESBS AT018, and ESBS AT019, marketed by Daicel Chemical Industries, Ltd. of Osaka, Japan.

A preferred embodiment for a slow core comprises polybutadiene, SBR, little or no zinc diacrylate (from 0-10 parts), optional zinc dimethacrylate, or a non zinc salt unsaturated monomer such as trimethylol propane triacrylate (SR-350 sold by the Sartomer Co.), a peroxide initiator. Other formulations for the core are disclosed in co-pending commonly owned application Ser. No. 10/845,721, which is incorporated herein by reference in its entirety. Alternatively, a non-peroxide, sulfur vulcanized formulation, such as that disclosed in pending U.S. application Ser. No. 10/772,689 can be used. This reference is incorporated by reference herein in its entirety.

The core diameter ranges from about 0.100 inch to about 1.64 inch, preferably from about 1.00 inch to about 1.62 inch. Typical core diameter ranges from 0.25 inch to 1.625 inch in increments of 0.05 inch. Common core sizes are 0.050 inch, 1.00 inch 1.10 inches, 1.20 inches, 1.30 inches, 1.40 inches, 1.45 inches, 1.50 inches 1.55 inches. 1.57 inches, 1.58 inches, 1.59 inches and 1.60 inches. That is, the size of the core plus any intermediate layer or layers may be within the same size or size range as the core sizes above.

Other suitable formulations for the core include, but are not limited to:

(1) Polyurethanes, such as those prepared from polyols and diisocyanates or polyisocyanates and those disclosed in U.S. Pat. Nos. 5,334,673 and 6,506,851 and U.S. patent application Ser. No. 10/194,059;

(2) Polyureas, such as those disclosed in U.S. Pat. No. 5,484,870 and U.S. patent application Ser. No. 10/228,311; and

(3) Polyurethane-urea hybrids, blends or copolymers comprising urethane or urea segments.

The core of the multi-layer golf ball preferably includes a polyurethane composition comprising the reaction product of at least one polyisocyanate and at least one curing agent. The curing agent can include, for example, one or more diamines, one or more polyols, or a combination thereof. The polyisocyanate can be combined with one or more polyols to form a prepolymer, which is then combined with the at least one curing agent. Thus, the polyols described herein are suitable for use in one or both components of the polyurethane material, i.e., as part of a prepolymer and in the curing agent.

The present invention is directed to highly-neutralized polymers and blends thereof ("HNP") for the use in golf equipment, preferably in ball cores, intermediate layers, and/or covers. The acid moieties of the HNP's, typically ethylene-based ionomers, are preferably neutralized greater than about 70%, more preferably greater than about 90%, and most preferably at least about 100%. The HNP's can be also be blended with a second polymer component, which, if containing an acid group, may be neutralized in a conventional manner, by the organic fatty acids of the present invention, or

both. The second polymer component, which may be partially or fully neutralized, preferably comprises ionomeric copolymers and terpolymers, ionomer precursors, thermoplastics, polyamides, polycarbonates, polyesters, polyurethanes, polyureas, thermoplastic elastomers, polybutadiene rubber, balata, metallocene-catalyzed polymers (grafted and non-grafted), single-site polymers, high-crystalline acid polymers, cationic ionomers, and the like. HNP polymers typically have a material hardness of between about 20 and about 80 Shore D, and a flexural modulus of between about 3,000 psi and about 200,000 psi.

In one embodiment of the present invention the HNP's are ionomers and/or their acid precursors that are preferably neutralized, either fully or partially, with organic acid copolymers or the salts thereof. The acid copolymers are preferably α -olefin, such as ethylene, C_{3-8} α,β -ethylenically unsaturated carboxylic acid, such as acrylic and methacrylic acid, copolymers. They may optionally contain a softening monomer, such as alkyl acrylate and alkyl methacrylate, wherein the alkyl groups have from 1 to 8 carbon atoms.

The acid copolymers can be described as E/X/Y copolymers where E is ethylene, X is an α,β -ethylenically unsaturated carboxylic acid, and Y is a softening comonomer. In a preferred embodiment, X is acrylic or methacrylic acid and Y is a C_{1-8} alkyl acrylate or methacrylate ester. X is preferably present in an amount from about 1 to about 35 weight percent of the polymer, more preferably from about 5 to about 30 weight percent of the polymer, and most preferably from about 10 to about 20 weight percent of the polymer. Y is preferably present in an amount from about 0 to about 50 weight percent of the polymer, more preferably from about 5 to about 25 weight percent of the polymer, and most preferably from about 10 to about 20 weight percent of the polymer.

Specific acid-containing ethylene copolymers include, but are not limited to, ethylene/acrylic acid/n-butyl acrylate, ethylene/methacrylic acid/n-butyl acrylate, ethylene/methacrylic acid/iso-butyl acrylate, ethylene/acrylic acid/iso-butyl acrylate, ethylene/methacrylic acid/n-butyl methacrylate, ethylene/acrylic acid/methyl methacrylate, ethylene/acrylic acid/methyl acrylate, ethylene/methacrylic acid/methyl acrylate, ethylene/methacrylic acid/methyl methacrylate, and ethylene/acrylic acid/n-butyl methacrylate. Preferred acid-containing ethylene copolymers include, ethylene/methacrylic acid/n-butyl acrylate, ethylene/acrylic acid/n-butyl acrylate, ethylene/methacrylic acid/methyl acrylate, ethylene/acrylic acid/ethyl acrylate, ethylene/methacrylic acid/ethyl acrylate, and ethylene/acrylic acid/methyl acrylate copolymers. The most preferred acid-containing ethylene copolymers are, ethylene/(meth) acrylic acid/n-butyl, acrylate, ethylene/(meth) acrylic acid/ethyl acrylate, and ethylene/(meth) acrylic acid/methyl acrylate copolymers.

Ionomers are typically neutralized with a metal cation, such as Li, Na, Mg, or Zn. It has been found that by adding sufficient organic acid or salt of organic acid, along with a suitable base, to the acid copolymer or ionomer, however, the ionomer can be neutralized, without losing processability, to a level much greater than for a metal cation. Preferably, the acid moieties are neutralized greater than about 80%, preferably from 90-100%, most preferably 100% without losing processability. This is accomplished by melt-blending an ethylene α,β -ethylenically unsaturated carboxylic acid copolymer, for example, with an organic acid or a salt of organic acid, and adding a sufficient amount of a cation source to increase the level of neutralization of all the acid moieties (including those in the acid copolymer and in the organic acid) to greater than 90%, (preferably greater than 100%).

The organic acids of the present invention are aliphatic, mono- or multi-functional (saturated, unsaturated, or multi-unsaturated) organic acids. Salts of these organic acids may also be employed. The salts of organic acids of the present invention include the salts of barium, lithium, sodium, zinc, bismuth, chromium, cobalt, copper, potassium, strontium, titanium, tungsten, magnesium, cesium, iron, nickel, silver, aluminum, tin, or calcium, salts of fatty acids, particularly stearic, bebenic, erucic, oleic, linoelic or dimerized derivatives thereof. It is preferred that the organic acids and salts of the present invention be relatively non-migratory (they do not bloom to the surface of the polymer under ambient temperatures) and non-volatile (they do not volatilize at temperatures required for melt-blending).

The ionomers of the invention may also be partially neutralized with metal cations. The acid moiety in the acid copolymer is neutralized about 1 to about 100%, preferably at least about 40 to about 100%, and more preferably at least about 90 to about 100%, to form an ionomer by a cation such as lithium, sodium, potassium, magnesium, calcium, barium, lead, tin, zinc, aluminum, or a mixture thereof.

The acid copolymers of the present invention are prepared from 'direct' acid copolymers, copolymers polymerized by adding all monomers simultaneously, or by grafting of at least one acid-containing monomer onto an existing polymer.

Thermoplastic polymer components, such as copolyetheresters, copolyesteresters, copolyetheramides, elastomeric polyolefins, styrene diene block copolymers and their hydrogenated derivatives, copolyesteramides, thermoplastic polyurethanes, such as copolyetherurethanes, copolyesterurethanes, copolyureaurethanes, copolyuretheaureas, epoxy-based polyurethanes, polycaprolactone-based polyurethanes, polyureas, and polycarbonate-based polyurethanes fillers, and other ingredients, if included, can be blended in either before, during, or after the acid moieties are neutralized, thermoplastic polyurethanes.

The copolyetheresters are comprised of a multiplicity of recurring long chain units and short chain units joined head-to-tail through ester linkages, the long chain units being represented by the formula:

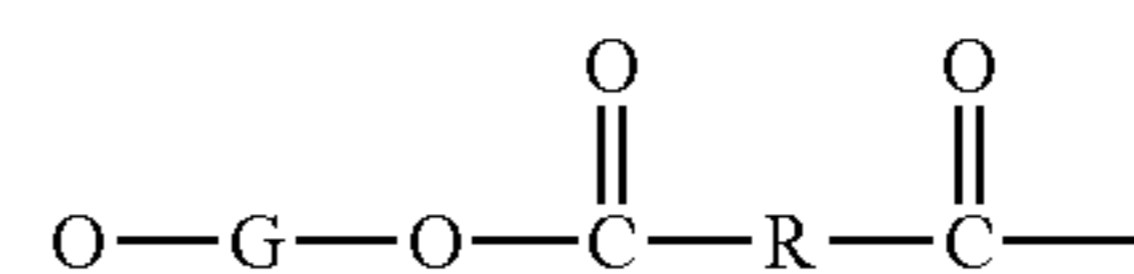

and the short chain units being represented by the formula:

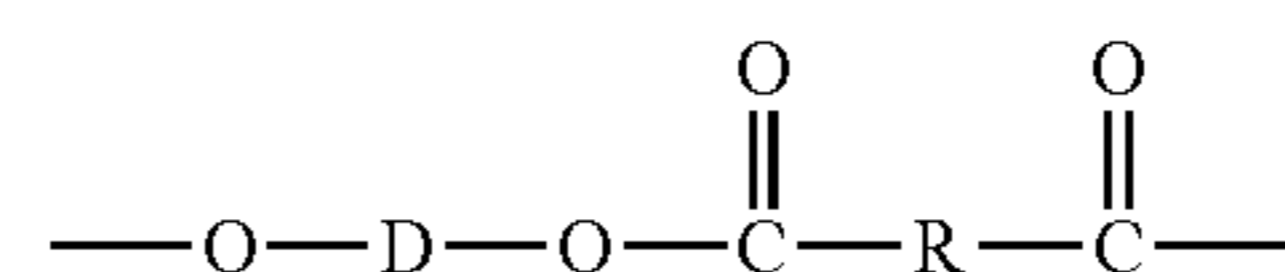

where G is a divalent radical remaining after the removal of terminal hydroxyl groups from a poly(alkylene oxide) glycol having a molecular weight of about 400-8000 and a carbon to oxygen ratio of about 2.0-4.3; R is a divalent radical remaining after removal of hydroxyl groups from a diol having a molecular weight less than about 250; provided said short chain ester units amount to about 15-95 percent by weight of said copolyetherester. The preferred copolyetherester polymers are those where the polyether segment is obtained by polymerization of tetrahydrofuran and the polyester segment is obtained by polymerization of tetramethylene glycol and phthalic acid. For purposes of the invention, the molar ether:

11

ester ratio can vary from 90:10 to 10:80; preferably 80:20 to 60:40; and the Shore D hardness is less than 70; preferably less than about 40.

The copolyetheramides are comprised of a linear and regular chain of rigid polyamide segments and flexible polyether segments, as represented by the general formula:

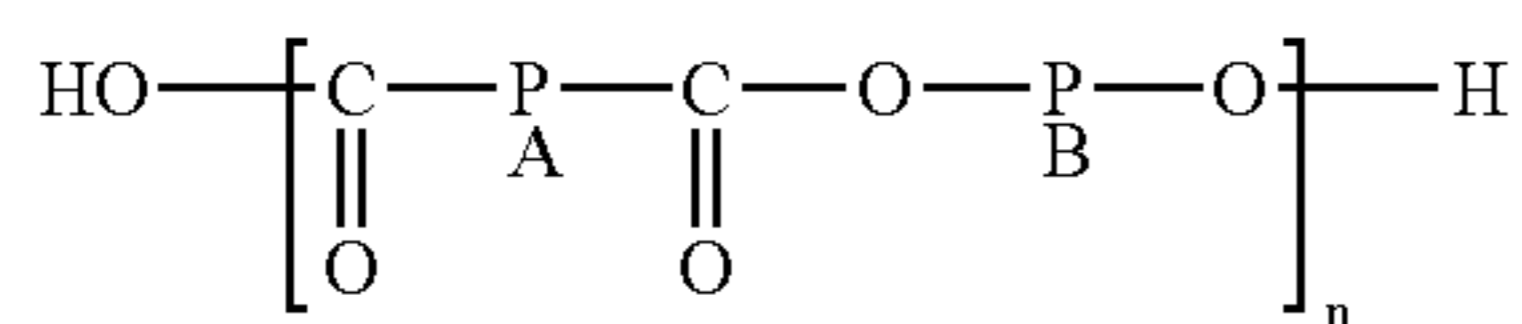

wherein PA is a linear saturated aliphatic polyamide sequence formed from a lactam or amino acid having a hydrocarbon chain containing 4 to 14 carbon atoms or from an aliphatic C₆-C₈ diamine, in the presence of a chain-limiting aliphatic carboxylic diacid having 4-20 carbon atoms; said polyamide having an average molecular weight between 300 and 15,000; and PB is a polyoxyalkylene sequence formed from linear or branched aliphatic polyoxyalkylene glycols, mixtures thereof or copolyethers derived therefrom, said polyoxyalkylene glycols having a molecular weight of less than or equal to 6000; and n indicates a sufficient number of repeating units so that said polyetheramide copolymer has an intrinsic viscosity of from about 0.6 to about 2.05. The preparation of these polyetheramides comprises the step of reacting a dicarboxylic polyamide, the COOH groups of which are located at the chain ends, with a polyoxyalkylene glycol hydroxylated at the chain ends, in the presence of a catalyst such as a tetraalkyl ortho titanate having the general formula Ti(OR)_x, wherein R is a linear branched aliphatic hydrocarbon radical having 1 to 24 carbon atoms. Again, the more polyether units incorporated into the copolyetheramide, the softer the polymer. The ether:amide ratios are as described above for the ether:ester ratios, as is the Shore D hardness.

The elastomeric polyolefins are polymers composed of ethylene and higher primary olefins such as propylene, hexene, octene, and optionally 1,4-hexadiene and or ethylidene norbornene or norbornadiene. The elastomeric polyolefins can be optionally functionalized with maleic anhydride, epoxy, hydroxy, amine, carboxylic acid, sulfonic acid, or thiol groups.

Thermoplastic polyurethanes are linear or slightly chain branched polymers consisting of hard blocks and soft elastomeric blocks. They are produced by reacting soft hydroxy terminated elastomeric polyethers or polyesters with diisocyanates, such as methylene diisocyanate ("MDI"), p-phenylene diisocyanate ("PPDI"), or toluene diisocyanate ("TDI"). These polymers can be chain extended with glycols, secondary diamines, diacids, or amino alcohols. The reaction products of the isocyanates and the alcohols are called urethanes and these blocks are relatively hard and high melting. These hard high melting blocks are responsible for the thermoplastic nature of the polyurethanes.

Block styrene diene copolymers and their hydrogenated derivatives are composed of polystyrene units and polydiene units. They may also be functionalized with moieties such as OH, NH₂, epoxy, COOH, and anhydride groups. The polydiene units are derived from polybutadiene, polyisoprene units or copolymers of these two. In the case of the copolymer it is possible to hydrogenate the polyolefin to give a saturated rubbery backbone segments. These materials are usually referred to as SBS, SIS, or SEBS thermoplastic elastomers and they can also be functionalized with maleic anhydride.

Grafted metallocene-catalyzed polymers are also useful for blending with the HNP's of the present invention. The

12

grafted metallocene-catalyzed polymers, while conventionally neutralized with metal cations, may also be neutralized, either partially or fully, with organic acids or salts thereof and an appropriate base. Grafted metallocene-catalyzed polymers useful, such as those disclosed in U.S. Pat. Nos. 5,703,166; 5,824,746; 5,981,658; and 6,025,442, which are incorporated herein by reference, in the golf balls of the invention are available in experimental quantities from DuPont under the tradenames SURLYN® NMO 525D, SURLYN® NMO 524D, and SURLYN® NMO 499D, all formerly known as the FUSABOND® family of polymers, or may be obtained by subjecting a non-grafted metallocene-catalyzed polymer to a post-polymerization reaction to provide a grafted metallocene-catalyzed polymer with the desired pendant group or groups. Examples of metallocene-catalyzed polymers to which functional groups may be grafted for use in the invention include, but are not limited to, homopolymers of ethylene and copolymers of ethylene and a second olefin, preferably, propylene, butene, pentene, hexene, heptene, octene, and norbornene. Generally, the invention includes golf balls having at least one layer comprising at least one grafted metallocene-catalyzed polymer or polymer blend, where the grafted metallocene-catalyzed polymer is produced by grafting a functional group onto a metallocene-catalyzed polymer having the formula:

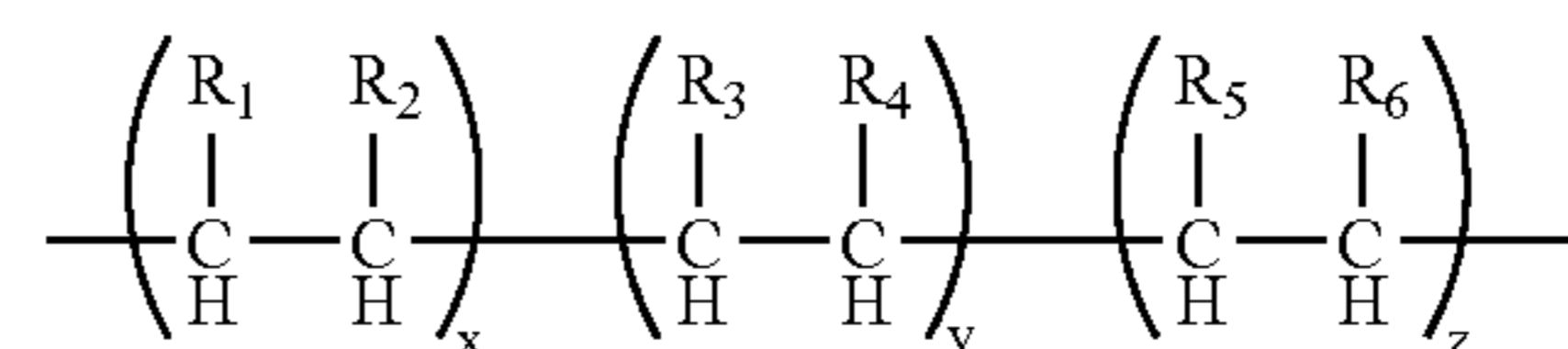

wherein R₁ is hydrogen, branched or straight chain alkyl such as methyl, ethyl, propyl, butyl, pentyl, hexyl, heptyl, and octyl, carbocyclic, or aromatic; R₂ is hydrogen, lower alkyl including C₁-C₅; carbocyclic, or aromatic; R₃ is hydrogen, lower alkyl including C₁-C₅, carbocyclic, or aromatic; R₄ is selected from the group consisting of H, C_nH_{2n+1}, where n=1 to 18, and phenyl, in which from 0 to 5H within R₄ can be replaced by substituents COOH, SO₃H, NH₂, F, Cl, Br, I, OH, SH, silicone, lower alkyl esters and lower alkyl ethers, with the proviso that R₃ and R₄ can be combined to form a bicyclic ring; R₅ is hydrogen, lower alkyl including C₁-C₅, carbocyclic, or aromatic; R₆ is hydrogen, lower alkyl including C₁-C₅, carbocyclic, or aromatic; and wherein x, y and z are the relative percentages of each co-monomer. X can range from about 1 to 99 percent or more preferably from about 10 to about 70 percent and most preferred, from about 10 to 50 percent. Y can be from 99 to 1 percent, preferably, from 90 to 30 percent, or most preferably, 90 to 50 percent. Z can range from about 0 to about 49 percent. One of ordinary skill in the art would understand that if an acid moiety is present as a ligand in the above polymer that it may be neutralized up to 100% with an organic fatty acid as described above.

Metallocene-catalyzed copolymers or terpolymers can be random or block and may be isotactic, syndiotactic, or atactic. The pendant groups creating the isotactic, syndiotactic, or atactic polymers are chosen to determine the interactions between the different polymer chains making up the resin to control the final properties of the resins used in golf ball covers, centers, or intermediate layers. As will be clear to those skilled in the art, grafted metallocene-catalyzed polymers useful in the invention that are formed from metallocene-catalyzed random or block copolymers or terpolymers

13

will also be random or block copolymers or terpolymers, and will have the same tacticity of the metallocene-catalyzed polymer backbone.

As used herein, the term “phrase branched or straight chain alkyl” means any substituted or unsubstituted acyclic carbon-containing compounds. Examples of alkyl groups include lower alkyl, for example, methyl, ethyl, n-propyl, iso-propyl, n-butyl, iso-butyl or t-butyl; upper alkyl, for example, octyl, nonyl, decyl, and the like; and lower alkylene, for example, ethylene, propylene, butylene, pentene, hexene, octene, norbornene, nonene, decene, and the like.

In addition, such alkyl groups may also contain various substituents in which one or more hydrogen atoms has been replaced by a functional group. Functional groups include, but are not limited to hydroxyl, amino, carboxyl, sulfonic amide, ester, ether, phosphates, thiol, nitro, silane and halogen (fluorine, chlorine, bromine and iodine), to mention but a few.

As used herein, the term “substituted and unsubstituted carbocyclic” means cyclic carbon-containing compounds, including, but not limited to cyclopentyl, cyclohexyl, cycloheptyl, and the like. Such cyclic groups may also contain various substituents in which one or more hydrogen atoms has been replaced by a functional group. Such functional groups include those described above, and lower alkyl groups having from 1-28 carbon atoms. The cyclic groups of the invention may further comprise a heteroatom.

As mentioned above, R_1 and R_2 can also represent any combination of alkyl, carbocyclic or aryl groups, for example, 1-cyclohexylpropyl, benzyl cyclohexylmethyl, 2-cyclohexylpropyl, 2,2-methylcyclohexylpropyl, 2,2-methylphenylpropyl, and 2,2-methylphenylbutyl.

Non-grafted metallocene-catalyzed polymers useful in the present invention are commercially available under the trade name AFFINITY® polyolefin plastomers and ENGAGE® polyolefin elastomers commercially available from Dow Chemical Company and DuPont-Dow. Other commercially available metallocene-catalyzed polymers can be used, such as EXACT®, commercially available from Exxon and INSIGHT®, commercially available from Dow. The EXACT® and INSIGHT® line of polymers also have novel Theological behavior in addition to their other properties as a result of using a metallocene catalyst technology. Metallocene-catalyzed polymers are also readily available from Sentinel Products Corporation of Hyannis, Mass., as foamed sheets for compression molding.

Monomers useful in the present invention include, but are not limited to, olefinic monomers having, as a functional group, sulfonic acid, sulfonic acid derivatives, such as chlorosulfonic acid, vinyl ethers, vinyl esters, primary, secondary, and tertiary amines, mono-carboxylic acids, dicarboxylic acids, partially or fully ester-derivatized mono-carboxylic and dicarboxylic acids, anhydrides of dicarboxylic acids, and cyclic imides of dicarboxylic acids.

In addition, metallocene-catalyzed polymers may also be functionalized by sulfonation, carboxylation, or the addition of an amine or hydroxy group. Metallocene-catalyzed polymers functionalized by sulfonation, carboxylation, or the addition of a hydroxy group may be converted to anionic ionomers by treatment with a base. Similarly, metallocene-catalyzed polymers functionalized by the addition of an amine may be converted to cationic ionomers by treatment with an alkyl halide, acid, or acid derivative.

The most preferred monomer is maleic anhydride, which, once attached to the metallocene-catalyzed polymer by the post-polymerization reaction, may be further subjected to a reaction to form a grafted metallocene-catalyzed polymer

14

containing other pendant or functional groups. For example, reaction with water will convert the anhydride to a dicarboxylic acid; reaction with ammonia, alkyl, or aromatic amine forms an amide; reaction with an alcohol results in the formation of an ester; and reaction with base results in the formation of an anionic ionomer.

The HNP's of the present invention may also be blended with single-site and metallocene catalysts and polymers formed therefrom. As used herein, the term “single-site catalyst,” such as those disclosed in U.S. Pat. No. 6,150,462 which is incorporated herein by reference, refers to a catalyst that contains an ancillary ligand that influences the steric and electronic characteristics of the polymerizing site in a manner that prevents formation of secondary polymerizing species.

The term “metallocene catalyst” refers to a single-site catalyst wherein the ancillary ligands are comprising substituted or unsubstituted cyclopentadienyl groups, and the term “non-metallocene catalyst” refers to a single-site catalyst other than a metallocene catalyst.

Non-metallocene single-site catalysts include, but are not limited to, the Brookhart catalyst, which has the following structure:

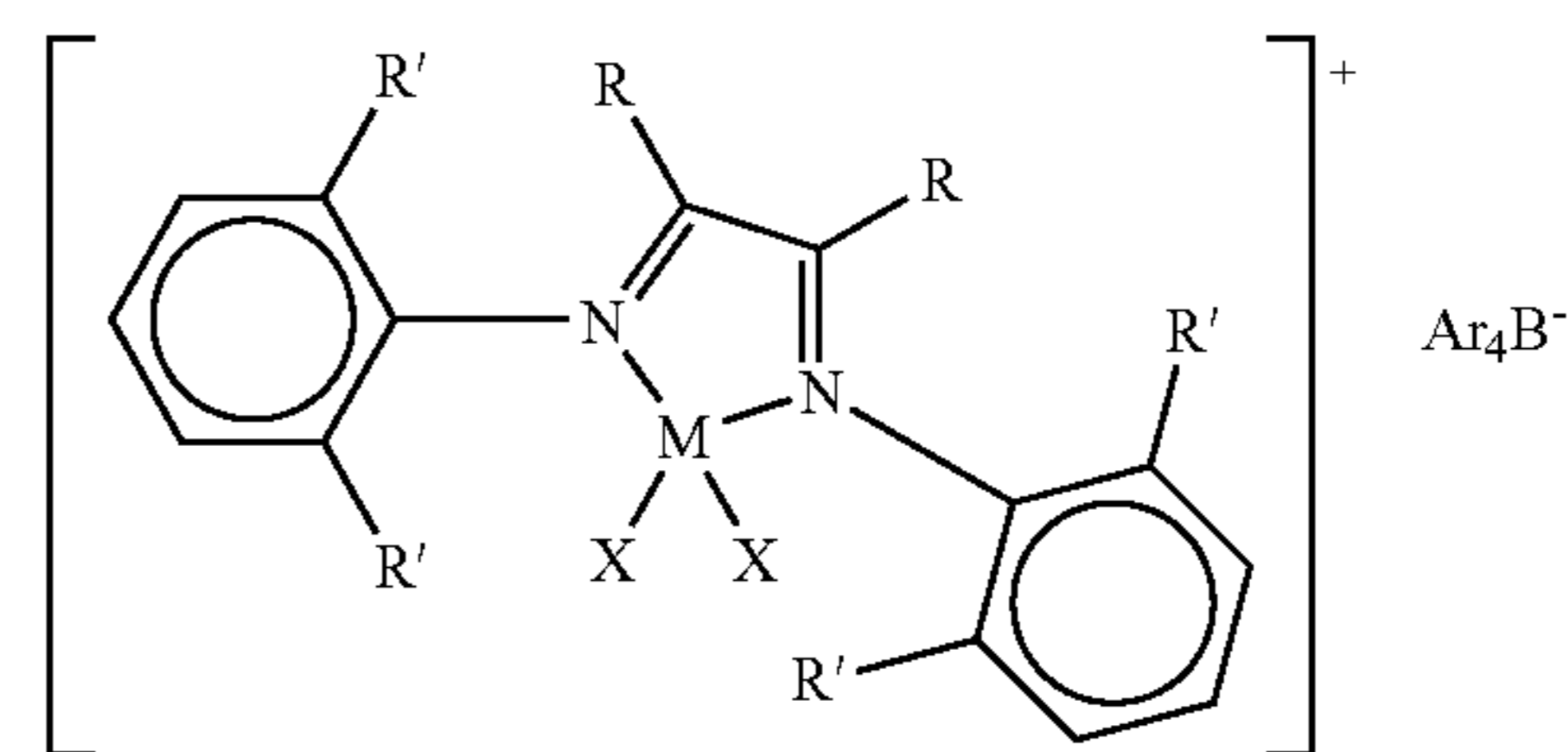

wherein M is nickel or palladium; R and R' are independently hydrogen, hydrocarbyl, or substituted hydrocarbyl; Ar is $(CF_3)_2C_6H_3$, and X is alkyl, methyl, hydride, or halide; the McConville catalyst, which has the structure:

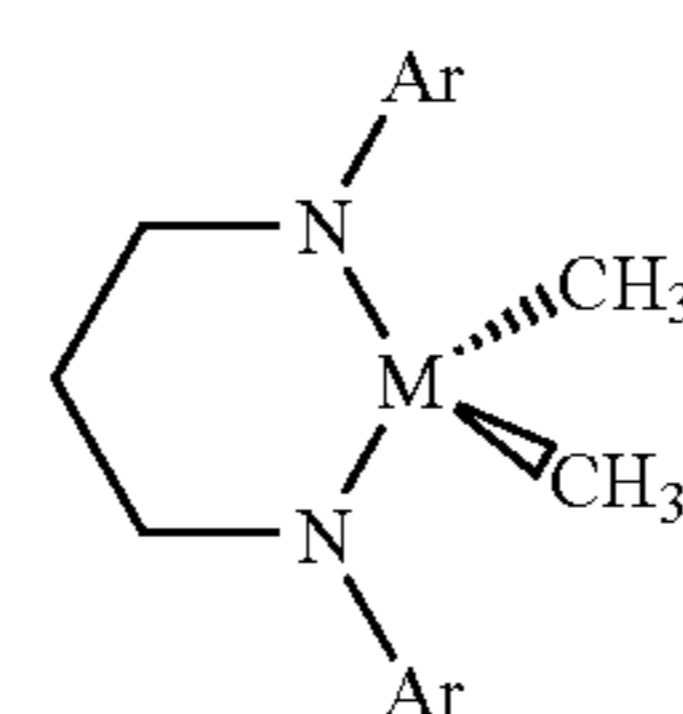

wherein M is titanium or zirconium. Iron (II) and cobalt (II) complexes with 2,6-bis(imino) pyridyl ligands, which have the structure:

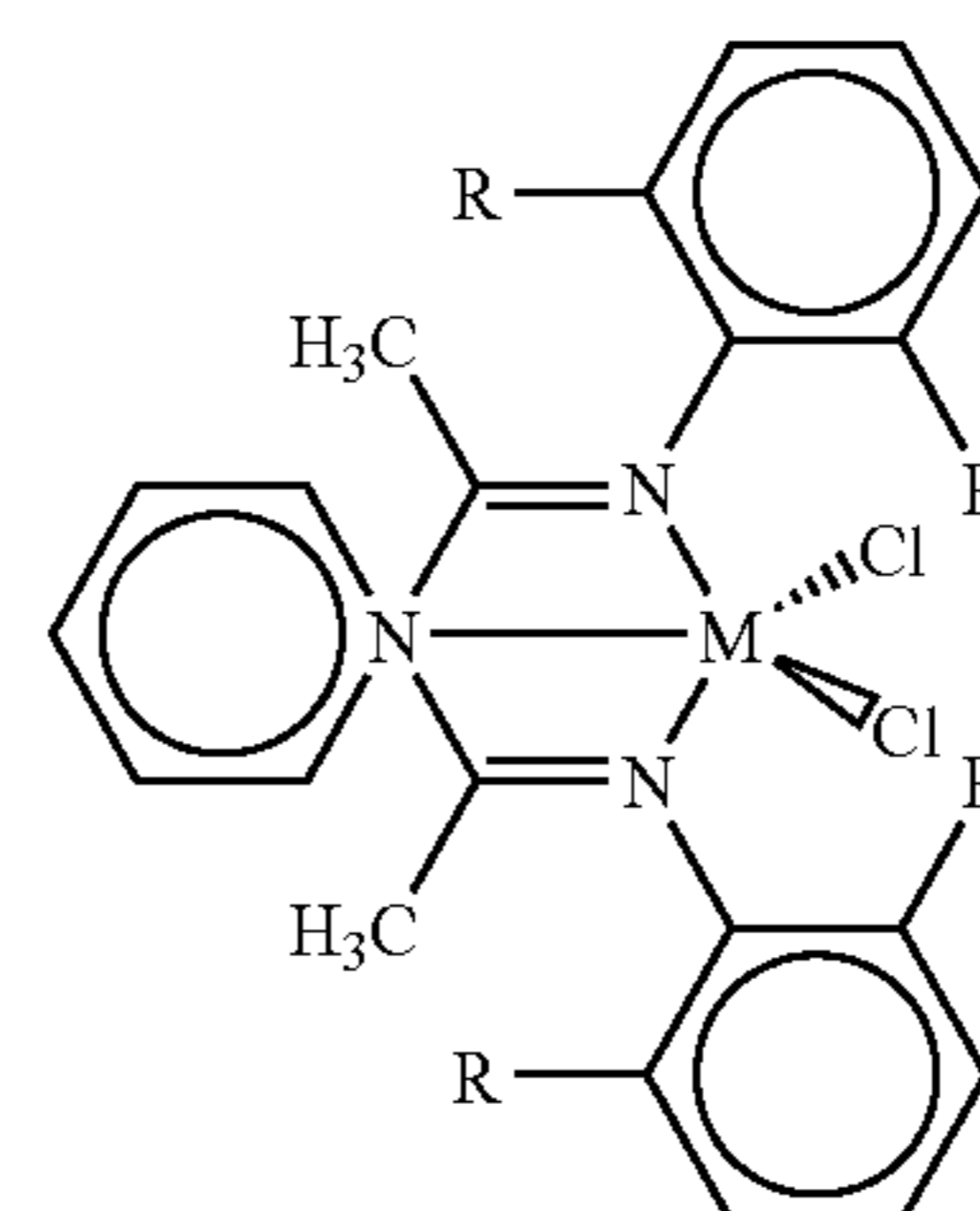

15

where M is the metal, and R is hydrogen, alkyl, or hydrocarbyl. Titanium or zirconium complexes with pyrroles as ligands also serve as single-site catalysts. These complexes have the structure:

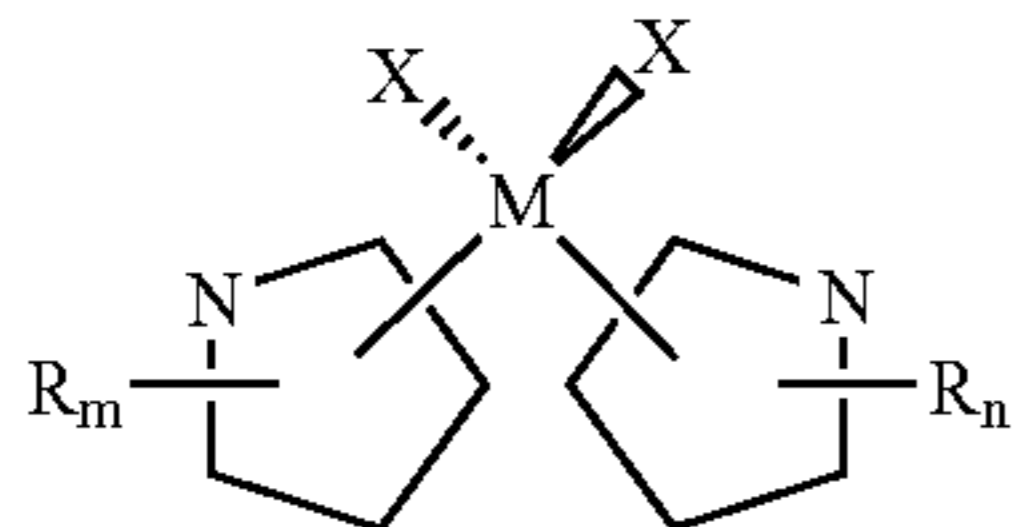

where M is the metal atom; m and n are independently 1 to 4, and indicate the number of substituent groups attached to the aromatic rings; R_m and R_n are independently hydrogen or alkyl; and X is halide or alkyl. Other examples include diimide complexes of nickel and palladium, which have the structure:

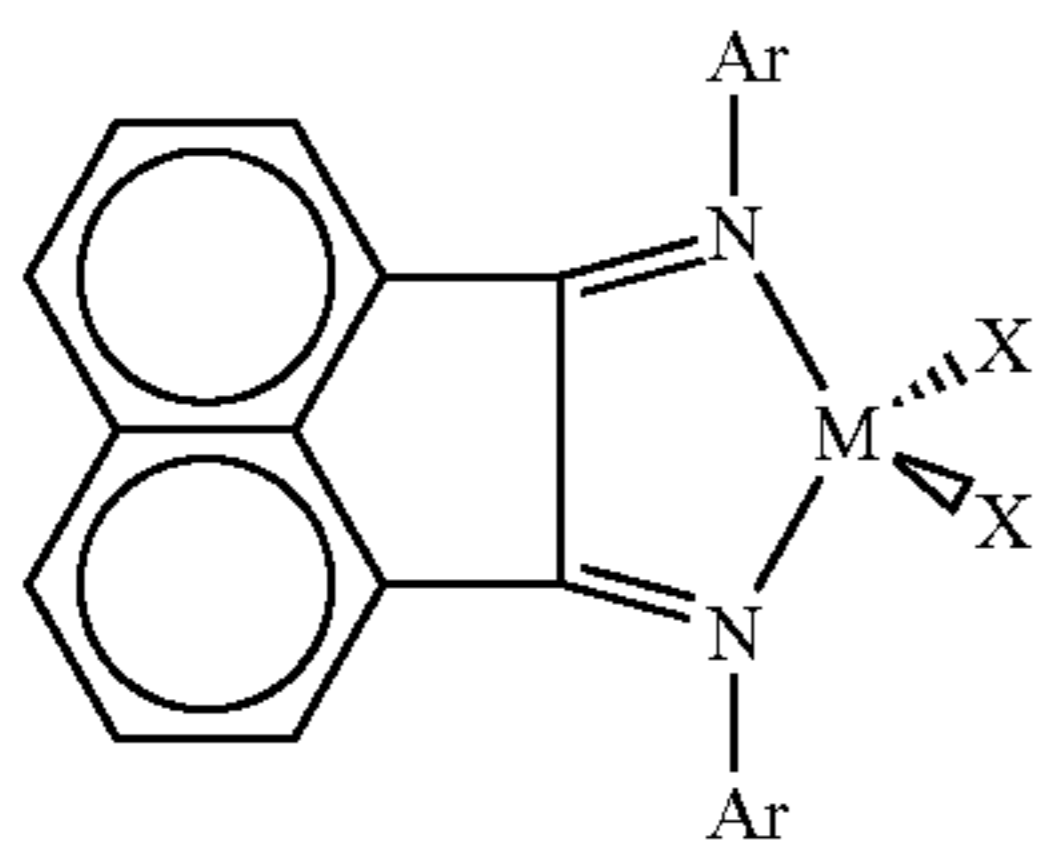

where Ar is aromatic, M is the metal, and X is halide or alkyl. Boratabenzene complexes of the Group IV or V metals also function as single-site catalysts. These complexes have the structure:

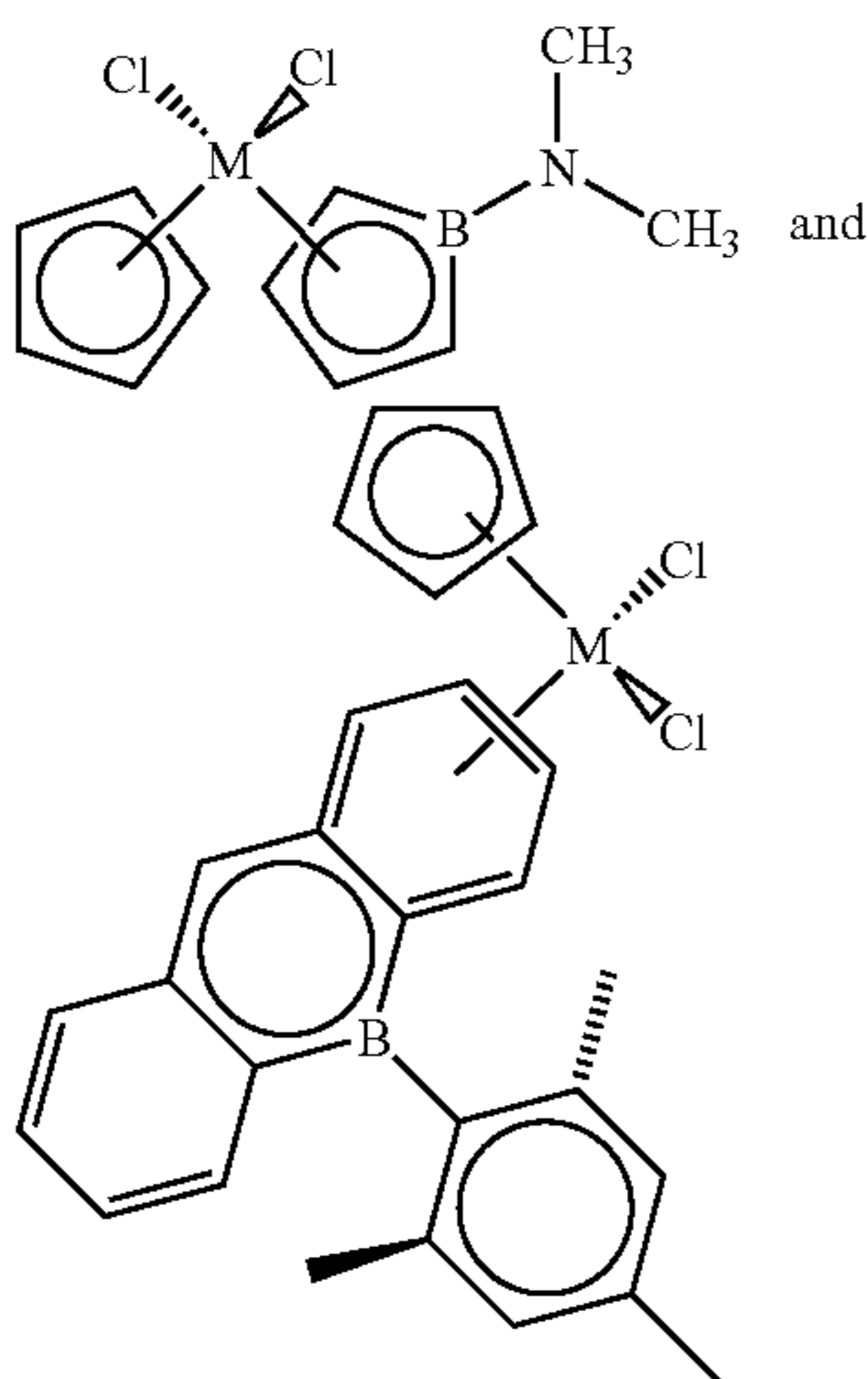

where B is boron and M is the metal atom.

As used herein, the term “single-site catalyzed polymer” refers to any polymer, copolymer, or terpolymer, and, in particular, any polyolefin polymerized using a single-site catalyst. The term “non-metallocene single-site catalyzed polymer” refers to any polymer, copolymer, or terpolymer, and, in particular, any polyolefin polymerized using a single-site catalyst other than a metallocene-catalyst. The catalysts discussed above are examples of non-metallocene single-site catalysts. The term “metallocene catalyzed polymer” refers to

16

any polymer, copolymer, or terpolymer, and, in particular, any polyolefin, polymerized using a metallocene catalyst.

As used herein, the term “single-site catalyzed polymer blend” refers to any blend of a single-site catalyzed polymer and any other type of polymer, preferably an ionomer, as well as any blend of a single-site catalyzed polymer with another single-site catalyzed polymer, including, but not limited to, a metallocene-catalyzed polymer.

The terms “grafted single-site catalyzed polymer” and “grafted single-site catalyzed polymer blend” refer to any single-site catalyzed polymer or single-site catalyzed polymer blend in which the single-site catalyzed polymer has been subjected to a post-polymerization reaction to graft at least one functional group onto the single-site catalyzed polymer. A “post-polymerization reaction” is any reaction that occurs after the formation of the polymer by a polymerization reaction.

The single-site catalyzed polymer, which may be grafted, may also be blended with polymers, such as non-grafted single-site catalyzed polymers, grafted single-site catalyzed polymers, ionomers, and thermoplastic elastomers. Preferably, the single-site catalyzed polymer is blended with at least one ionomer of the preset invention.

Grafted single-site catalyzed polymers useful in the golf balls of the invention may be obtained by subjecting a non-grafted single-site catalyzed polymer to a post-polymerization reaction to provide a grafted single-site catalyzed polymer with the desired pendant group or groups. Examples of single-site catalyzed polymers to which functional groups may be grafted for use in the invention include, but are not limited to, homopolymers of ethylene and propylene and copolymers of ethylene and a second olefin, preferably, propylene, butene, pentene, hexene, heptene, octene, and norbornene. Monomers useful in the present invention include, but are not limited to olefinic monomers having as a functional group sulfonic acid, sulfonic acid derivatives, such as chlorosulfonic acid, vinyl ethers, vinyl esters, primary, secondary, and tertiary amines, epoxies, isocyanates, mono-carboxylic acids, dicarboxylic acids, partially or fully ester derivatized mono-carboxylic and dicarboxylic acids, anhydrides of dicarboxylic acids, and cyclic imides of dicarboxylic acids. Generally, this embodiment of the invention includes golf balls having at least one layer comprising at least one grafted single-site catalyzed polymer or polymer blend, where the grafted single-site catalyzed polymer is produced by grafting a functional group onto a single-site catalyzed polymer having the formula:

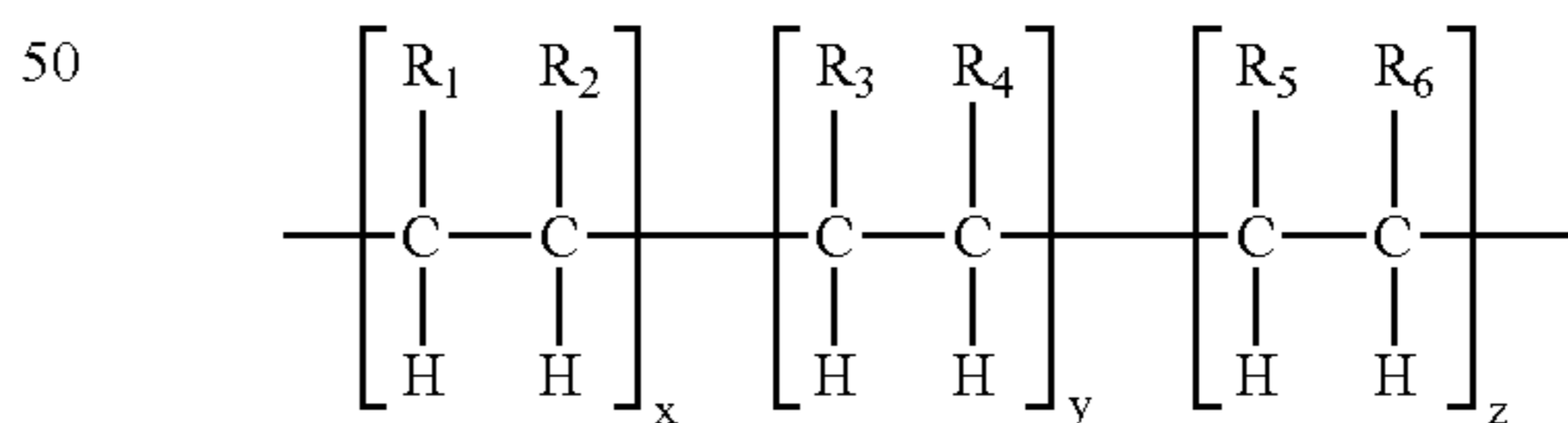

where R_1 is hydrogen, branched or straight chain alkyl such as methyl, ethyl, propyl, butyl, pentyl, hexyl, heptyl, and octyl, carbocyclic, aromatic or heterocyclic; R_2 , R_3 , R_5 , and R_6 are hydrogen, lower alkyl including C_1 - C_5 , carbocyclic, aromatic or heterocyclic; R_4 is H, C_nH_{2n+1} , where $n=1$ to 18, and phenyl, in which from 0 to 5H within R_4 can be replaced by substituents such as COOH, SO_3H , NH_2 , F, Cl, Br, I, OH, SH, epoxy, isocyanate, silicone, lower alkyl esters and lower alkyl ethers; also, R_3 and R_4 can be combined to form a bicyclic ring; and x, y and z are the relative percentages of each co-monomer. X can range from about 1 to about 100 percent

19

to 5; B is a straight chain or branched aliphatic group, a substituted straight chain or branched aliphatic group, or an aromatic or substituted aromatic group; and $n=1$ to 100. Preferably, M^{+x} is one of the following: Li^+ , Na^+ , K^+ , Mg^{+2} , Zn^{+2} , Ca^{+2} , Mn^{+2} , Al^{+3} , Ti^{+x} , Zr^{+x} , W^{+x} or Hf^{+x} .

Exemplary anionic polyurethane ionomers with anionic groups attached to the polyol component of the polyurethane are characterized by the above chemical structure where A is a straight chain or branched aliphatic group, a substituted straight chain or branched aliphatic group, or an aromatic or substituted aromatic group; $B=R-Z^-M^{+x}$; R is a straight chain or branched aliphatic group, a substituted straight chain or branched aliphatic group, or an aromatic or substituted aromatic group; $Z=SO_3^-$, CO_2^- or HPO_3^- ; M is a group IA, IB, IIA, IIB, IIIA, IIIB, IVA, IVB, VA, VB, VIA, VIB, VIIB or VIIIB metal; $x=1$ to 5; and $n=1$ to 100. Preferably, M^{+x} is one of the following: Li^+ , Na^+ , K^+ , Mg^{+2} , Zn^{+2} , Ca^{+2} , Mn^{+2} , Al^{+3} , Ti^{+x} , Zr^{+x} , W^{+x} or Hf^{+x} .

Examples of suitable anionic polyurea ionomers with anionic groups attached to the diisocyanate component have a chemical structure according to the following chemical structure:

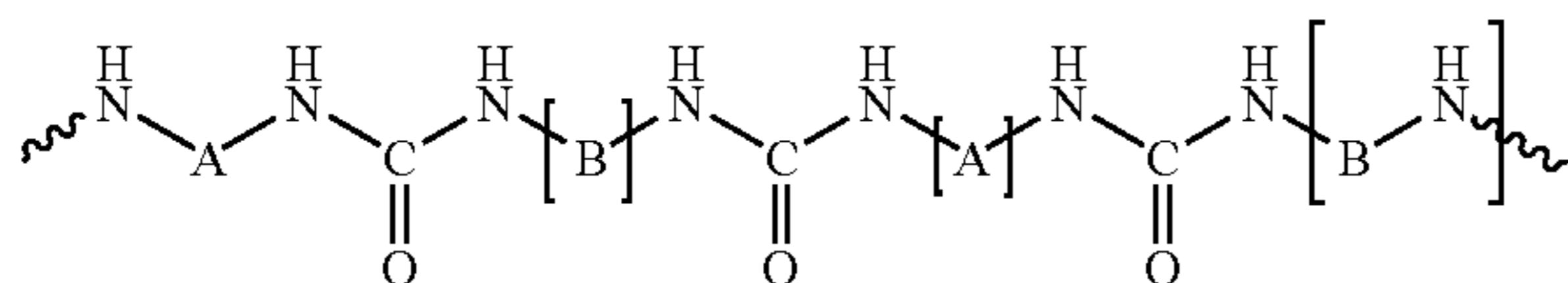

where $A=R-Z^-M^{+x}$; R is a straight chain or branched aliphatic group, a substituted straight chain or branched aliphatic group, or an aromatic or substituted aromatic group; $Z=SO_3^-$, CO_2^- or HPO_3^- ; M is a group IA, IB, IIA, IIB, IIIA, IIIB, IVA, IVB, VA, VB, VIA, VIB, VIIB or VIIIB metal; $x=1$ to 5; and B is a straight chain or branched aliphatic group, a substituted straight chain or branched aliphatic group, or an aromatic or substituted aromatic group. Preferably, M^{+x} is one of the following: Li^+ , Na^+ , K^+ , Mg^{+2} , Zn^{+2} , Ca^{+2} , Mn^{+2} , Al^{+3} , Ti^{+x} , Zr^{+x} , W^{+x} , or Hf^{+x} .

Suitable anionic polyurea ionomers with anionic groups attached to the amine component of the polyurea are characterized by the above chemical structure where A is a straight chain or branched aliphatic group, a substituted straight chain or branched aliphatic group, or an aromatic or substituted aromatic group; $B=R-Z^-M^{+x}$; R is a straight chain or branched aliphatic group, a substituted straight chain or branched aliphatic group, or an aromatic or substituted aromatic group; $Z=SO_3^-$, CO_2^- , or HPO_3^- ; M is a group IA, IB, IIA, IIB, IIIA, IIIB, IVA, IVB, VA, VB, VIA, VIB, VIIB or VIIIB metal; and $x=1$ to 5. Preferably, M^{+x} is one of the following: Li^+ , Na^+ , K^+ , Mg^{+2} , Zn^{+2} , Ca^{+2} , Mn^{+2} , Al^{+3} , Ti^{+x} , Zr^{+x} , W^{+x} , or Hf^{+x} . The anionic polyurethane and polyurea ionomers may also be neutralized up to 100% by the organic fatty acids described above.

The anionic polymers useful in the present invention, such as those disclosed in U.S. Pat. No. 6,221,960 which is incorporated herein by reference, include any homopolymer, copolymer or terpolymer having neutralizable hydroxyl and/or dealkylable ether groups, and in which at least a portion of the neutralizable or dealkylable groups are neutralized or dealkylated with a metal ion.

As used herein "neutralizable" or "dealkylable" groups refer to a hydroxyl or ether group pendent from the polymer chain and capable of being neutralized or dealkylated by a metal ion, preferably a metal ion base. These neutralized polymers have improved properties critical to golf ball per-

20

formance, such as resiliency, impact strength and toughness and abrasion resistance. Suitable metal bases are ionic compounds comprising a metal cation and a basic anion. Examples of such bases include hydroxides, carbonates, acetates, oxides, sulfides, and the like.

The particular base to be used depends upon the nature of the hydroxyl or ether compound to be neutralized or dealkylated, and is readily determined by one skilled in the art. Preferred anionic bases include hydroxides, carbonates, oxides and acetates.

The metal ion can be any metal ion which forms an ionic compound with the anionic base. The metal is not particularly limited, and includes alkali metals, preferably lithium, sodium or potassium; alkaline earth metals, preferably magnesium or calcium; transition metals, preferably titanium, zirconium, or zinc; and Group III and IV metals. The metal ion can have a +1 to +5 charge. Most preferably, the metal is lithium, sodium, potassium, zinc, magnesium, titanium, tungsten, or calcium, and the base is hydroxide, carbonate or acetate.

The anionic polymers useful in the present invention include those which contain neutralizable hydroxyl and/or dealkylable ether groups. Exemplary polymers include ethylene vinyl alcohol copolymers, polyvinyl alcohol, polyvinyl acetate, poly(p-hydroxymethylene styrene), and p-methoxy styrene, to name but a few. It will be apparent to one skilled in the art that many such polymers exist and thus can be used in the compositions of the invention. In general, the anionic polymer can be described by the chemical structure:

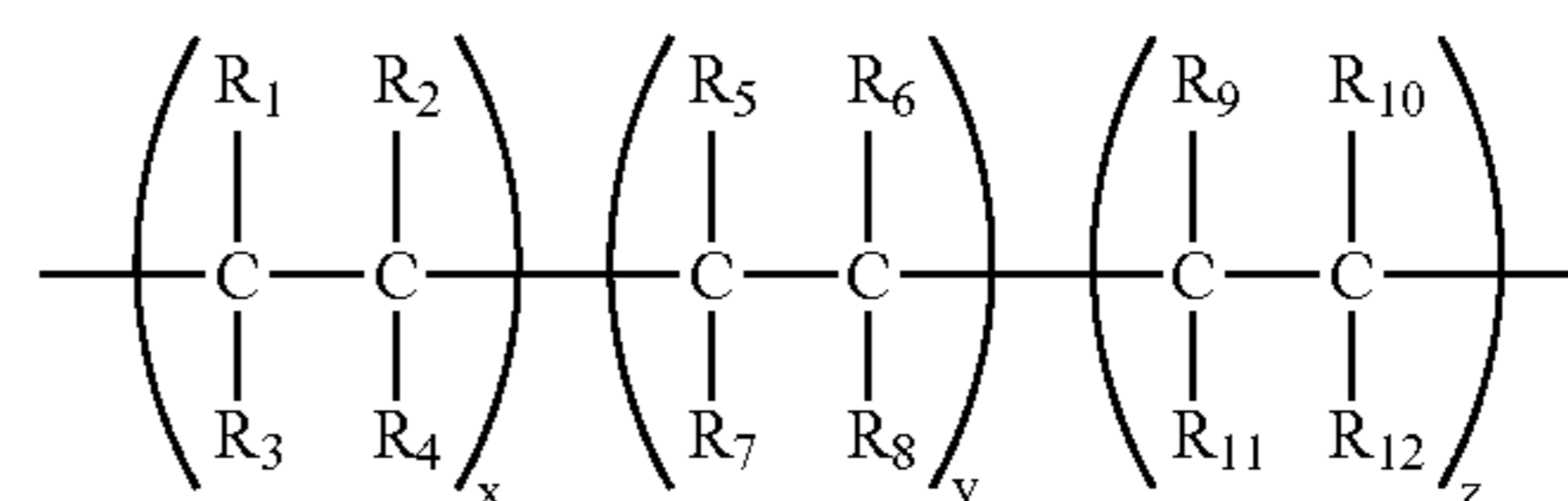

where R_1 is OH, $OC(O)R_a$, $O-M^{+V}$, $(CH_2)_nR_b$, $(CHR_z)_nR_b$, or aryl, wherein n is at least 1, R_a is a lower alkyl, M is a metal ion, V is an integer from 1 to 5, R_b is OH, $OC(O)R_a$, $O-M^{+V}$, and R_z is a lower alkyl or aryl, and R_2 , R_3 and R_4 are each independently hydrogen, straight-chain or branched-chain lower alkyl. R_2 , R_3 and R_4 may also be similarly substituted. Preferably n is from 1 to 12, more preferably 1 to 4.

The term "substituted," as used herein, means one or more hydrogen atoms has been replaced by a functional group. Functional groups include, but are not limited to, hydroxyl, amino, carboxyl, sulfonic, amide, ether, ether, phosphates, thiol, nitro, silane, and halogen, as well as many others which are quite familiar to those of ordinary skill in this art.

The terms "alkyl" or "lower alkyl," as used herein, includes a group of from about 1 to 30 carbon atoms, preferably 1 to 10 carbon atoms.

In the anionic polymers useful in the present invention, at least a portion of the neutralizable or dealkylable groups of R_1 are neutralized or dealkylated by an organic fatty acid, a salt thereof, a metal base, or a mixture thereof to form the corresponding anionic moiety. The portion of the neutralizable or dealkylable groups which are neutralized or dealkylated can be between about 1 to about 100 weight percent, preferably between about 50 to about 100 weight percent, more preferably before about 90 to about 100.

Neutralization or dealkylation may be performed by melting the polymer first, then adding a metal ion in an extruder. The degree of neutralization or dealkylation is controlled by

varying the amount of metal ion added. Any method of neutralization or dealkylation available to those of ordinary skill in the art may also be suitably employed.

In one embodiment, the anionic polymer is repeating units any one of the three homopolymer units in the chemical structure above. In a preferred embodiment, R_2 , R_3 and R_4 are hydrogen, and R_1 is hydroxyl, i.e., the anionic polymer is a polyvinyl alcohol homopolymer in which a portion of the hydroxyl groups have been neutralized with a metal base. In another preferred embodiment, R_2 , R_3 and R_4 are hydrogen, R_1 is $OC(O)R_a$, and R_a is methyl, i.e., the anionic polymer is a polyvinyl acetate homopolymer in which a portion of the methyl ether groups have been dealkylated with a metal ion.

The anionic polymer can also be a copolymer of two different repeating units having different substituents, or a terpolymer of three different repeating units described in the above formula. In this embodiment, the polymer can be a random copolymer, an alternating copolymer, or a block copolymer, where the term "copolymer" includes terpolymers.

In another embodiment, the anionic polymer is a copolymer, wherein R_5 , R_6 , R_7 and R_8 are each independently selected from the group defined above for R_2 . The first unit of the copolymer can comprise from about 1 to 99 percent weight percent of the polymer, preferably from about 5 to 50 weight percent, and the second unit of the copolymer can comprise from about 99 to 1 weight percent, preferably from about 95 to 50 weight percent. In one preferred embodiment, the anionic polymer is a random, alternating or block copolymer of units (Ia) and (Ib) wherein R_1 is hydroxyl, and each of the remaining R groups is hydrogen, i.e., the polymer is a copolymer of ethylene and vinyl alcohol. In another preferred embodiment, the anionic polymer is a random, alternating or block copolymer of units (Ia) and (Ib) wherein R_1 is $OC(O)R_5$, where R_5 is methyl, and each of the remaining R groups is hydrogen, i.e., the polymer is a copolymer of ethylene and vinyl acetate.

In another embodiment, the anionic polymer is an anionic polymer having neutralizable hydroxyl and/or dealkylable ether groups of as in the above chemical structure wherein R_{1-9} and R_b and R_z are as defined above; R_{10-11} are each independently selected from the group as defined above for R_2 ; and R_{12} is OH or $OC(O)R_{13}$, where R_{13} is a lower alkyl; wherein x, y and z indicate relative weight percent of the different units. X can be from about 99 to about 50 weight percent of the polymer, y can be from about 1 to about 50 weight percent of the polymer, and z ranges from about 0 to about 50 weight percent of the polymer. At least a portion of the neutralizable groups R_1 are neutralized. When the amount of z is greater than zero, a portion of the groups R_{10} can also be fully or partially neutralized, as desired.

In particular, the anionic polymers and blends thereof can comprise compatible blends of anionic polymers and ionomers, such as the ionomers described above, and ethylene acrylic methacrylic acid ionomers, and their terpolymers, sold commercially under the trade names SURLYN® and IOTEK® by DuPont and Exxon respectively. The anionic polymer blends useful in the golf balls of the invention can also include other polymers, such as polyvinylalcohol, copolymers of ethylene and vinyl alcohol, poly(ethylene), poly(heptylethylene), poly(hexyldecylethylene), poly(isopentylethylene), poly(butyl acrylate), acrylate), poly(2-ethylbutyl acrylate), poly(heptyl acrylate), poly(2-methylbutyl acrylate), poly(3-methylbutyl acrylate), poly(N-octadecylacrylamide), poly(octadecyl methacrylate), poly(butoxyethylene), poly(methoxyethylene), poly(pentyloxyethylene), poly(1,1-dichloroethylene), poly(4-

[(2-butoxyethoxy)methyl]styrene), poly[oxy(ethoxymethyl)ethylene], poly(oxyethylethylene), poly(oxytetramethylene), poly(oxytrimethylene), poly(silanes) and poly(silazanes), polyamides, polycarbonates, polyesters, styrene block copolymers, polyetheramides, polyurethanes, main-chain heterocyclic polymers and poly(furan tetracarboxylic acid diimides), as well as the classes of polymers to which they belong.

The anionic polymer compositions of the present invention typically have a flexural modulus of from about 500 psi to about 300,000 psi, preferably from about 2000 to about 200,000 psi. The anionic polymer compositions typically have a material hardness of at least about 15 Shore A, preferably between about 30 Shore A and 80 Shore D, more preferably between about 50 Shore A and 60 Shore D. The loss tangent, or dissipation factor, is a ratio of the loss modulus over the dynamic shear storage modulus, and is typically less than about 1, preferably less than about 0.01, and more preferably less than about 0.001 for the anionic polymer compositions measured at about 23° C. The specific gravity is typically greater than about 0.7, preferably greater than about 1, for the anionic polymer compositions. The dynamic shear storage modulus, or storage modulus, of the anionic polymer compositions at about 23° C. is typically at least about 10,000 dyn/cm².

The golf balls of the present invention may comprise a variety of constructions. In one embodiment of the present invention, golf ball includes a center, an inner cover layer surrounding the center, and an outer cover layer. Preferably, the center is solid. More preferably, the center is a solid, single-layer core. In a preferred embodiment, the solid center comprises the HNP's of the present invention. In an alternative embodiment, the solid center may include compositions having a base rubber, a crosslinking agent, a filler, and a co-crosslinking or initiator agent, and the inner cover layer comprises the HNP's of the present invention.

The base rubber typically includes natural or synthetic rubbers. A preferred base rubber is 1,4-polybutadiene having a cis-structure of at least 40%. More preferably, the base rubber comprises high-Mooney-viscosity rubber. If desired, the polybutadiene can also be mixed with other elastomers known in the art such as natural rubber, polyisoprene rubber and/or styrene-butadiene rubber in order to modify the properties of the core.

The crosslinking agent includes a metal salt of an unsaturated fatty acid such as a zinc salt or a magnesium salt of an unsaturated fatty acid having 3 to 8 carbon atoms such as acrylic or methacrylic acid. Suitable cross linking agents include metal salt diacrylates, dimethacrylates and monomethacrylates wherein the metal is magnesium, calcium, zinc, aluminum, sodium, lithium or nickel. The crosslinking agent is present in an amount from about 15 to about 30 parts per hundred of the rubber, preferably in an amount from about 19 to about 25 parts per hundred of the rubber and most preferably having about 20 to 24 parts crosslinking agent per hundred of rubber. The core compositions of the present invention may also include at least one organic or inorganic cis-trans catalyst to convert a portion of the cis-isomer of polybutadiene to the trans-isomer, as desired.

The initiator agent can be any known polymerization initiator which decomposes during the cure cycle. Suitable initiators include peroxide compounds such as dicumyl peroxide, 1,1-di-(t-butylperoxy) 3,3,5-trimethyl cyclohexane, a-a bis-(t-butylperoxy)diisopropylbenzene, 2,5-dimethyl-2,5 di-(t-butylperoxy)hexane or di-t-butyl peroxide and mixtures thereof.

Fillers, any compound or composition that can be used to vary the density and other properties of the core, typically include materials such as tungsten, zinc oxide, barium sulfate, silica, calcium carbonate, zinc carbonate, metals, metal oxides and salts, regrind (recycled core material typically ground to about 30 mesh particle), high-Mooney-viscosity rubber regrind, and the like.

The golf ball centers of the present invention may also comprise a variety of constructions. For example, the core may comprise a single layer or a plurality of layers. The center may also comprise a formed of a tensioned elastomeric material. In another embodiment of the present invention, golf ball comprises a solid center surrounded by at least one additional solid outer core layer, or intermediate layer. The "dual" core is surrounded by a "double" cover comprising an inner cover layer and an outer cover layer.

Preferably, the solid center comprises the HNP's of the present invention. In another embodiment, the inner cover layer comprises the highly-neutralized acid copolymers of the present invention. In an alternative embodiment, the outer core layer comprises the highly-neutralized acid copolymers of the present invention.

At least one of the outer core or intermediate layers is formed of a resilient rubber-based component comprising a high-Mooney-viscosity rubber, and a crosslinking agent present in an amount from about 20 to about 40 parts per hundred, from about 30 to about 38 parts per hundred, and most preferably about 37 parts per hundred. It should be understood that the term "parts per hundred" is with reference to the rubber by weight.

When the golf ball of the present invention includes an intermediate layer, such as an outer core layer or an inner cover layer, any or all of these layer(s) may comprise thermoplastic and thermosetting material, but preferably the intermediate layer(s), if present, comprise any suitable material, such as ionic copolymers of ethylene and an unsaturated monocarboxylic acid which are available under the trademark SURLYN® of E.I. DuPont de Nemours & Co., of Wilmington, Del., or IOTEK® or ESCOR® of Exxon. These are copolymers or terpolymers of ethylene and methacrylic acid or acrylic acid partially neutralized with salts of zinc, sodium, lithium, magnesium, potassium, calcium, manganese, nickel or the like, in which the salts are the reaction product of an olefin having from 2 to 8 carbon atoms and an unsaturated monocarboxylic acid having 3 to 8 carbon atoms. The carboxylic acid groups of the copolymer may be totally or partially neutralized and might include methacrylic, crotonic, maleic, fumaric or itaconic acid.

This golf ball can likewise include one or more homopolymeric or copolymeric inner cover materials, such as:

- (1) Vinyl resins, such as those formed by the polymerization of vinyl chloride, or by the copolymerization of vinyl chloride with vinyl acetate, acrylic esters or vinylidene chloride;
- (2) Polyolefins, such as polyethylene, polypropylene, polybutylene and copolymers such as ethylene methacrylate, ethylene ethylacrylate, ethylene vinyl acetate, ethylene methacrylic or ethylene acrylic acid or propylene acrylic acid and copolymers and homopolymers produced using a single-site catalyst or a metallocene catalyst;
- (3) Polyurethanes, such as those prepared from polyols and diisocyanates or polyisocyanates, in particular PPDI-based thermoplastic polyurethanes, and those disclosed in U.S. Pat. No. 5,334,673;
- (4) Polyureas, such as those disclosed in U.S. Pat. No. 5,484,870;

- (5) Polyamides, such as poly(hexamethylene adipamide) and others prepared from diamines and dibasic acids, as well as those from amino acids such as poly(caprolactam), and blends of polyamides with SURLYN®, polyethylene, ethylene copolymers, ethylene-propylene-non-conjugated diene terpolymer, and the like;
- (6) Acrylic resins and blends of these resins with poly vinyl chloride, elastomers, and the like;
- (7) Thermoplastics, such as urethane; olefinic thermoplastic rubbers, such as blends of polyolefins with ethylene-propylene-non-conjugated diene terpolymer; block copolymers of styrene and butadiene, isoprene or ethylene-butylene rubber; or copoly(ether-amide), such as PEBAX®, sold by ELF Atochem of Philadelphia, Pa.;
- (8) Polyphenylene oxide resins or blends of polyphenylene oxide with high impact polystyrene as sold under the trademark NORYL® by General Electric Company of Pittsfield, Mass.;
- (9) Thermoplastic polyesters, such as polyethylene terephthalate, polybutylene terephthalate, polyethylene terephthalate/glycol modified, poly(trimethylene terephthalate), and elastomers sold under the trademarks HYTREL® by E.I. DuPont de Nemours & Co. of Wilmington, Del., and LOMOD® by General Electric Company of Pittsfield, Mass.;
- (10) Blends and alloys, including polycarbonate with acrylonitrile butadiene styrene, polybutylene terephthalate, polyethylene terephthalate, styrene maleic anhydride, polyethylene, elastomers, and the like, and polyvinyl chloride with acrylonitrile butadiene styrene or ethylene vinyl acetate or other elastomers; and
- (11) Blends of thermoplastic rubbers with polyethylene, propylene, polyacetal, nylon, polyesters, cellulose esters, and the like.

Preferably, the inner cover includes polymers, such as ethylene, propylene, butene-1 or hexane-1 based homopolymers or copolymers including functional monomers, such as acrylic and methacrylic acid and fully or partially neutralized ionomer resins and their blends, methyl acrylate, methyl methacrylate homopolymers and copolymers, imidized, amino group containing polymers, polycarbonate, reinforced polyamides, polyphenylene oxide, high impact polystyrene, polyether ketone, polysulfone, poly(phenylene sulfide), acrylonitrile-butadiene, acrylic-styrene-acrylonitrile, poly(ethylene terephthalate), poly(butylene terephthalate), poly(vinyl alcohol), poly(tetrafluoroethylene) and their copolymers including functional comonomers, and blends thereof. Suitable cover compositions also include a polyether or polyester thermoplastic urethane, a thermoset polyurethane, a low modulus ionomer, such as acid-containing ethylene copolymer ionomers, including E/X/Y terpolymers where E is ethylene, X is an acrylate or methacrylate-based softening comonomer present in about 0 to 50 weight percent and Y is acrylic or methacrylic acid present in about 5 to 35 weight percent. More preferably, in a low spin rate embodiment designed for maximum distance, the acrylic or methacrylic acid is present in about 16 to 35 weight percent, making the ionomer a high modulus ionomer. In a higher spin embodiment, the inner cover layer includes an ionomer where an acid is present in about 10 to 15 weight percent and includes a softening comonomer. Additionally, high-density polyethylene ("HDPE"), low-density polyethylene ("LDPE"), LLDPE, and homo- and co-polymers of polyolefin are suitable for a variety of golf ball layers.

In one embodiment, the outer cover preferably includes a polyurethane composition comprising the reaction product of at least one polyisocyanate, polyol, and at least one curing

agent. Any polyisocyanate available to one of ordinary skill in the art is suitable for use according to the invention. Exemplary polyisocyanates include, but are not limited to, 4,4'-diphenylmethane diisocyanate ("MDI"); polymeric MDI; carbodiimide-modified liquid MDI; 4,4'-dicyclohexylmethane diisocyanate ("H₁₂MDI"); p-phenylene diisocyanate ("PPDI"); m-phenylene diisocyanate ("MPDI"); toluene diisocyanate ("TDI"); 3,3'-dimethyl-4,4'-biphenylene diisocyanate ("TODI"); isophoronediiisocyanate ("IPDI"); hexamethylene diisocyanate ("HDI"); naphthalene diisocyanate ("NDI"); xylene diisocyanate ("XDI"); p-tetramethylxylene diisocyanate ("p-TMXDI"); m-tetramethylxylene diisocyanate ("m-TMXDI"); ethylene diisocyanate; propylene-1,2-diisocyanate; tetramethylene-1,4-diisocyanate; cyclohexyl diisocyanate; 1,6-hexamethylene-diisocyanate ("HDI"); dodecane-1,12-diisocyanate; cyclobutane-1,3-diisocyanate; cyclohexane-1,3-diisocyanate; cyclohexane-1,4-diisocyanate; 1-isocyanato-3,3,5-trimethyl-5-isocyanatomethylcyclohexane; methyl cyclohexylene diisocyanate; triisocyanate of HDI; triisocyanate of 2,4,4-trimethyl-1,6-hexane diisocyanate ("TMDI"); tetracene diisocyanate; naphthalene diisocyanate; anthracene diisocyanate; isocyanurate of toluene diisocyanate; uretdione of hexamethylene diisocyanate; and mixtures thereof. Polyisocyanates are known to those of ordinary skill in the art as having more than one isocyanate group, e.g., di-isocyanate, tri-isocyanate, and tetra-isocyanate. Preferably, the polyisocyanate includes MDI, PPDI, TDI, or a mixture thereof, and more preferably, the polyisocyanate includes MDI. It should be understood that, as used herein, the term "MDI" includes 4,4'-diphenylmethane diisocyanate, polymeric MDI, carbodiimide-modified liquid MDI, and mixtures thereof and, additionally, that the diisocyanate employed may be "low free monomer," understood by one of ordinary skill in the art to have lower levels of "free" monomer isocyanate groups, typically less than about 0.1% free monomer groups. Examples of "low free monomer" diisocyanates include, but are not limited to Low Free Monomer MDI, Low Free Monomer TDI, and Low Free Monomer PPDI.

The at least one polyisocyanate should have less than about 14% unreacted NCO groups. Preferably, the at least one polyisocyanate has no greater than about 7.5% NCO, and more preferably, less than about 7.0%.

Any polyol available to one of ordinary skill in the art is suitable for use according to the invention. Exemplary polyols include, but are not limited to, polyether polyols, hydroxy-terminated polybutadiene (including partially/fully hydrogenated derivatives), polyester polyols, polycaprolactone polyols, and polycarbonate polyols. In one preferred embodiment, the polyol includes polyether polyol. Examples include, but are not limited to, polytetramethylene ether glycol ("PTMEG"), polyethylene propylene glycol, polyoxypropylene glycol, and mixtures thereof. The hydrocarbon chain can have saturated or unsaturated bonds and substituted or unsubstituted aromatic and cyclic groups. Preferably, the polyol of the present invention includes PTMEG.

In another embodiment, polyester polyols are included in the polyurethane material of the invention. Suitable polyester polyols include, but are not limited to, polyethylene adipate glycol; polybutylene adipate glycol; polyethylene propylene adipate glycol; o-phthalate-1,6-hexanediol; poly(hexamethylene adipate) glycol; and mixtures thereof. The hydrocarbon chain can have saturated or unsaturated bonds, or substituted or unsubstituted aromatic and cyclic groups.

In another embodiment, polycaprolactone polyols are included in the materials of the invention. Suitable polycaprolactone polyols include, but are not limited to, 1,6-hex-

anediol-initiated polycaprolactone, diethylene glycol initiated polycaprolactone, trimethylol propane initiated polycaprolactone, neopentyl glycol initiated polycaprolactone, 1,4-butanediol-initiated polycaprolactone, and mixtures thereof. The hydrocarbon chain can have saturated or unsaturated bonds, or substituted or unsubstituted aromatic and cyclic groups.

In yet another embodiment, the polycarbonate polyols are included in the polyurethane material of the invention. Suitable polycarbonates include, but are not limited to, polyphthalate carbonate and poly(hexamethylene carbonate) glycol. The hydrocarbon chain can have saturated or unsaturated bonds, or substituted or unsubstituted aromatic and cyclic groups. In one embodiment, the molecular weight of the polyol is from about 200 to about 4000.

Polyamine curatives are also suitable for use in the polyurethane composition of the invention and have been found to improve cut, shear, and impact resistance of the resultant balls. Preferred polyamine curatives include, but are not limited to, 3,5-dimethylthio-2,4-toluenediamine and isomers thereof; 3,5-diethyltoluene-2,4-diamine and isomers thereof, such as 3,5-diethyltoluene-2,6-diamine; 4,4'-bis-(sec-butylamino)-diphenylmethane; 1,4-bis-(sec-butylamino)-benzene, 4,4'-methylene-bis-(2-chloroaniline); 4,4'-methylene-bis-(3-chloro-2,6-diethylaniline) ("MCDEA"); polytetramethyleneoxide-di-p-aminobenzoate; N,N'-dialkyl-diamino diphenyl methane; p,p'-methylene dianiline ("MDA"); m-phenylenediamine ("MPDA"); 4,4'-methylene-bis-(2-chloroaniline) ("MOCA"); 4,4'-methylene-bis-(2,6-diethylaniline) ("MDEA"); 4,4'-methylene-bis-(2,3-dichloroaniline) ("MDCA"); 4,4'-diamino-3,3'-diethyl-5,5'-dimethyl diphenylmethane; 2,2', 3,3'-tetrachloro diamino diphenylmethane; trimethylene glycol di-p-aminobenzoate; and mixtures thereof. Preferably, the curing agent of the present invention includes 3,5-dimethylthio-2,4-toluenediamine and isomers thereof, such as ETHACURE 300, commercially available from Albermarle Corporation of Baton Rouge, La. Suitable polyamine curatives, which include both primary and secondary amines, preferably have molecular weights ranging from about 64 to about 2000.

At least one of a diol, triol, tetraol, or hydroxy-terminated curatives may be added to the aforementioned polyurethane composition. Suitable diol, triol, and tetraol groups include ethylene glycol; diethylene glycol; polyethylene glycol; propylene glycol; polypropylene glycol; lower molecular weight polytetramethylene ether glycol; 1,3-bis(2-hydroxyethoxy)benzene; 1,3-bis-[2-(2-hydroxyethoxy)ethoxy]benzene; 1,3-bis-{2-[2-(2-hydroxyethoxy)ethoxy]ethoxy}benzene; 1,4-butanediol; 1,5-pentanediol; 1,6-hexanediol; resorcinol-di-(β-hydroxyethyl)ether; hydroquinone-di-(β-hydroxyethyl) ether; and mixtures thereof. Preferred hydroxy-terminated curatives include 1,3-bis(2-hydroxyethoxy)benzene; 1,3-bis-[2-(2-hydroxyethoxy)ethoxy]benzene; 1,3-bis-{2-[2-(2-hydroxyethoxy)ethoxy]ethoxy}benzene; 1,4-butanediol, and mixtures thereof. Preferably, the hydroxy-terminated curatives have molecular weights ranging from about 48 to 2000. It should be understood that molecular weight, as used herein, is the absolute weight average molecular weight and would be understood as such by one of ordinary skill in the art.

Both the hydroxy-terminated and amine curatives can include one or more saturated, unsaturated, aromatic, and cyclic groups. Additionally, the hydroxy-terminated and amine curatives can include one or more halogen groups. The polyurethane composition can be formed with a blend or mixture of curing agents. If desired, however, the polyurethane composition may be formed with a single curing agent.

In a preferred embodiment of the present invention, saturated polyurethanes used to form cover layers, preferably the outer cover layer, and may be selected from among both castable thermoset and thermoplastic polyurethanes.

In this embodiment, the saturated polyurethanes of the present invention are substantially free of aromatic groups or moieties. Saturated polyurethanes suitable for use in the invention are a product of a reaction between at least one polyurethane prepolymer and at least one saturated curing agent. The polyurethane prepolymer is a product formed by a reaction between at least one saturated polyol and at least one saturated diisocyanate. As is well known in the art, a catalyst may be employed to promote the reaction between the curing agent and the isocyanate and polyol.

Saturated diisocyanates which can be used include, without limitation, ethylene diisocyanate; propylene-1,2-diisocyanate; tetramethylene-1,4-diisocyanate; 1,6-hexamethylene diisocyanate (“HDI”); 2,2,4-trimethylhexamethylene diisocyanate; 2,4,4-trimethylhexamethylene diisocyanate; dodecane-1,12-diisocyanate; dicyclohexylmethane diisocyanate; cyclobutane-1,3-diisocyanate; cyclohexane-1,3-diisocyanate; cyclohexane-1,4-diisocyanate; 1-isocyanato-3,3,5-trimethyl-5-isocyanatomethylcyclohexane; isophorone diisocyanate (“IPDI”); methyl cyclohexylene diisocyanate; triisocyanate of HDI; triisocyanate of 2,2,4-trimethyl-1,6-hexane diisocyanate (“TMDI”). The most preferred saturated diisocyanates are 4,4'-dicyclohexylmethane diisocyanate (“HMDI”) and isophorone diisocyanate (“IPDI”).

Saturated polyols which are appropriate for use in this invention include without limitation polyether polyols such as polytetramethylene ether glycol and poly(oxypropylene) glycol. Suitable saturated polyester polyols include polyethylene adipate glycol, polyethylene propylene adipate glycol, polybutylene adipate glycol, polycarbonate polyol and ethylene oxide-capped polyoxypropylene diols. Saturated polycaprolactone polyols which are useful in the invention include diethylene glycol-initiated polycaprolactone, 1,4-butanediol-initiated polycaprolactone, 1,6-hexanediol-initiated polycaprolactone; trimethylol propane-initiated polycaprolactone, neopentyl glycol initiated polycaprolactone, and polytetramethylene ether glycol-initiated polycaprolactone. The most preferred saturated polyols are polytetramethylene ether glycol and PTMEG-initiated polycaprolactone.

Suitable saturated curatives include 1,4-butanediol, ethylene glycol, diethylene glycol, polytetramethylene ether glycol, propylene glycol; trimethanolpropane; tetra-(2-hydroxypropyl)-ethylenediamine; isomers and mixtures of isomers of cyclohexyldimethylol, isomers and mixtures of isomers of cyclohexane bis(methylamine); triisopropanolamine; ethylene diamine; diethylene triamine; triethylene tetramine; tetraethylene pentamine; 4,4'-dicyclohexylmethane diamine; 2,2,4-trimethyl-1,6-hexanediamine; 2,4,4-trimethyl-1,6-hexanediamine; diethyleneglycol di-(aminopropyl)ether; 4,4'-bis-(sec-butylamino)-dicyclohexylmethane; 1,2-bis-(sec-butylamino)cyclohexane; 1,4-bis-(sec-butylamino)cyclohexane; isophorone diamine; hexamethylene diamine; propylene diamine; 1-methyl-2,4-cyclohexyl diamine; 1-methyl-2,6-cyclohexyl diamine; 1,3-diaminopropane; dimethylamino propylamine; diethylamino propylamine; imido-bispropylamine; isomers and mixtures of isomers of diaminocyclohexane; monoethanolamine; diethanolamine; triethanolamine; monoisopropanolamine; and diisopropanolamine. The most preferred saturated curatives are 1,4-butanediol, 1,4-cyclohexyldimethylol and 4,4'-bis-(sec-butylamino)-dicyclohexylmethane.

The compositions of the invention may also be polyurea-based, which are distinctly different from polyurethane com-

positions, but also result in desirable aerodynamic and aesthetic characteristics when used in golf ball components. The polyurea-based compositions are preferably saturated in nature.

Without being bound to any particular theory, it is now believed that substitution of the long chain polyol segment in the polyurethane prepolymer with a long chain polyamine oligomer soft segment to form a polyurea prepolymer, improves shear, cut, and resiliency, as well as adhesion to other components. Thus, the polyurea compositions of this invention may be formed from the reaction product of an isocyanate and polyamine prepolymer crosslinked with a curing agent. For example, polyurea-based compositions of the invention may be prepared from at least one isocyanate, at least one polyether amine, and at least one diol curing agent or at least one diamine curing agent.

Any polyamine available to one of ordinary skill in the art is suitable for use in the polyurea prepolymer. Polyether amines are particularly suitable for use in the prepolymer. As used herein, “polyether amines” refer to at least polyoxyalkyleneamines containing primary amino groups attached to the terminus of a polyether backbone. Due to the rapid reaction of isocyanate and amine, and the insolubility of many urea products, however, the selection of diamines and polyether amines is limited to those allowing the successful formation of the polyurea prepolymers. In one embodiment, the polyether backbone is based on tetramethylene, propylene, ethylene, trimethylolpropane, glycerin, and mixtures thereof.

Suitable polyether amines include, but are not limited to, methyl diethanolamine; polyoxyalkylenediamines such as, polytetramethylene ether diamines, polyoxypropylenetriamine, and polyoxypropylene diamines; poly(ethylene oxide capped oxypropylene)ether diamines; propylene oxide-based triamines; triethyleneglycoldiamines; trimethylolpropane-based triamines; glycerin-based triamines; and mixtures thereof. In one embodiment, the polyether amine used to form the prepolymer is JEFFAMINE® D2000 (manufactured by Huntsman Chemical Co. of Austin, Tex.).

The molecular weight of the polyether amine for use in the polyurea prepolymer may range from about 100 to about 5000. As used herein, the term “about” is used in connection with one or more numbers or numerical ranges, should be understood to refer to all such numbers, including all numbers in a range. In one embodiment, the polyether amine molecular weight is about 200 or greater, preferably about 230 or greater. In another embodiment, the molecular weight of the polyether amine is about 4000 or less. In yet another embodiment, the molecular weight of the polyether amine is about 600 or greater. In still another embodiment, the molecular weight of the polyether amine is about 3000 or less. In yet another embodiment, the molecular weight of the polyether amine is between about 1000 and about 3000, and more preferably is between about 1500 to about 2500. Because lower molecular weight polyether amines may be prone to forming solid polyureas, a higher molecular weight oligomer, such as Jeffamine D2000, is preferred.

In one embodiment, the polyether amine has the generic structure:

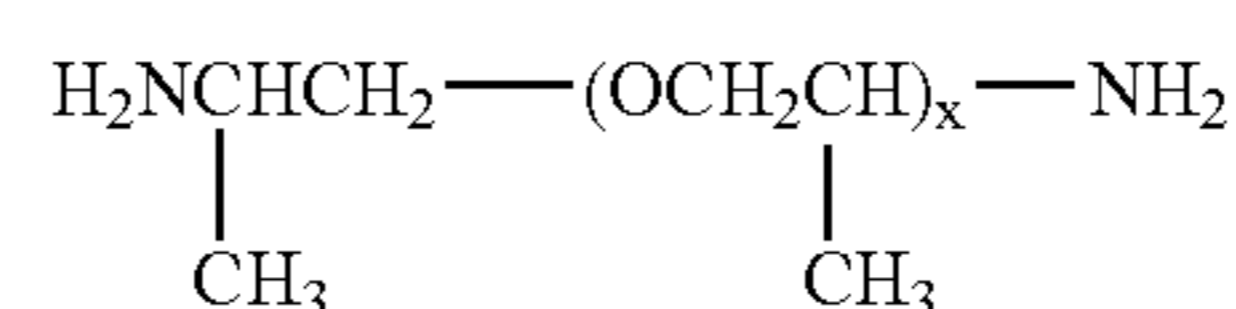

wherein the repeating unit x has a value ranging from about 1 to about 70. Even more preferably, the repeating unit may be from about 5 to about 50, and even more preferably is from about 12 to about 35.

In another embodiment, the polyether amine has the generic structure:

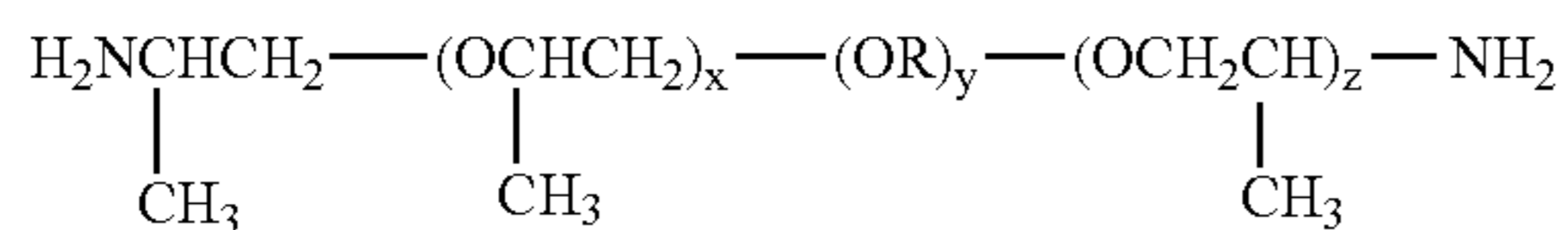

wherein the repeating units x and z have combined values from about 3.6 to about 8 and the repeating unit y has a value ranging from about 9 to about 50, and wherein R is $\text{---}(\text{CH}_2)_a\text{---}$, where "a" may be a repeating unit ranging from about 1 to about 10.

In yet another embodiment, the polyether amine has the generic structure:

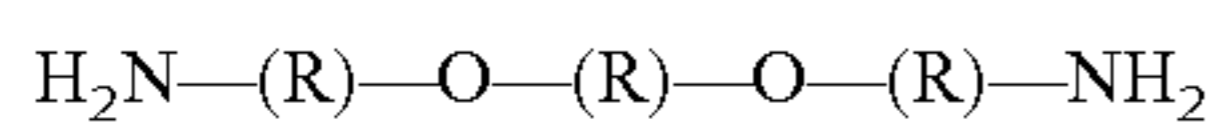

wherein R is $\text{---}(\text{CH}_2)_a\text{---}$, and "a" may be a repeating unit ranging from about 1 to about 10.

As briefly discussed above, some amines may be unsuitable for reaction with the isocyanate because of the rapid reaction between the two components. In particular, shorter chain amines are fast reacting. In one embodiment, however, a hindered secondary diamine may be suitable for use in the prepolymer. Without being bound to any particular theory, it is believed that an amine with a high level of steric hindrance, e.g., a tertiary butyl group on the nitrogen atom, has a slower reaction rate than an amine with no hindrance or a low level of hindrance. For example, 4,4'-bis-(sec-butylamino)-dicyclohexylmethane (CLEARLINK® 1000) may be suitable for use in combination with an isocyanate to form the polyurea prepolymer.

Any isocyanate available to one of ordinary skill in the art is suitable for use in the polyurea prepolymer. Isocyanates for use with the present invention include aliphatic, cycloaliphatic, araliphatic, aromatic, any derivatives thereof, and combinations of these compounds having two or more isocyanate (NCO) groups per molecule. The isocyanates may be organic polyisocyanate-terminated prepolymers. The isocyanate-containing reactable component may also include any isocyanate-functional monomer, dimer, trimer, or multimeric adduct thereof, prepolymer, quasi-prepolymer, or mixtures thereof. Isocyanate-functional compounds may include monoisocyanates or polyisocyanates that include any isocyanate functionality of two or more.

Suitable isocyanate-containing components include diisocyanates having the generic structure: O=C=N---R---N=C=O , where R is preferably a cyclic, aromatic, or linear or branched hydrocarbon moiety containing from about 1 to about 20 carbon atoms. The diisocyanate may also contain one or more cyclic groups or one or more phenyl groups. When multiple cyclic or aromatic groups are present, linear and/or branched hydrocarbons containing from about 1 to about 10 carbon atoms can be present as spacers between the cyclic or aromatic groups. In some cases, the cyclic or aromatic group(s) may be substituted at the 2-, 3-, and/or 4-positions, or at the ortho-, meta-, and/or para-positions, respectively. Substituted groups may include, but are not limited to, halogens, primary, secondary, or tertiary hydrocarbon groups, or a mixture thereof.

Examples of diisocyanates that can be used with the present invention include, but are not limited to, substituted

and isomeric mixtures including 2,2'-, 2,4'-, and 4,4'-diphenylmethane diisocyanate (MDI); 3,3'-dimethyl-4,4'-biphenylene diisocyanate (TODI); toluene diisocyanate (TDI); polymeric MDI; carbodiimide-modified liquid 4,4'-diphenylmethane diisocyanate; para-phenylene diisocyanate (PPDI); meta-phenylene diisocyanate (MPDI); triphenyl methane-4,4'- and triphenyl methane-4,4'-triisocyanate; naphthylene-1,5-diisocyanate; 2,4'-, 4,4'-, and 2,2-biphenyl diisocyanate; polyphenyl polymethylene polyisocyanate (PMDI); mixtures of MDI and PMDI; mixtures of PMDI and TDI; ethylene diisocyanate; propylene-1,2-diisocyanate; tetramethylene-1,2-diisocyanate; tetramethylene-1,3-diisocyanate; tetramethylene-1,4-diisocyanate; 1,6-hexamethylene-diisocyanate (HDI); octamethylene diisocyanate; decamethylene diisocyanate; 2,2,4-trimethylhexamethylene diisocyanate; 2,4,4-trimethylhexamethylene diisocyanate; dodecane-1,12-diisocyanate; cyclobutane-1,3-diisocyanate; cyclohexane-1,2-diisocyanate; cyclohexane-1,3-diisocyanate; cyclohexane-1,4-diisocyanate; methyl-cyclohexylene diisocyanate (HTDI); 2,4-methylcyclohexane diisocyanate; 2,6-methylcyclohexane diisocyanate; 4,4'-dicyclohexyl diisocyanate; 2,4'-dicyclohexyl diisocyanate; 1,3,5-cyclohexane triisocyanate; isocyanatomethylcyclohexane isocyanate; 1-isocyanato-3,3,5-trimethyl-5-isocyanatomethylcyclohexane; isocyanatoethylcyclohexane isocyanate; bis(isocyanatomethyl)-cyclohexane diisocyanate; 4,4'-bis(isocyanatomethyl)dicyclohexane; 2,4'-bis(isocyanatomethyl)dicyclohexane; isophorone diisocyanate (IPDI); triisocyanate of HDI; triisocyanate of 2,2,4-trimethyl-1,6-hexane diisocyanate (TMDI); 4,4'-dicyclohexylmethane diisocyanate (H_{12} MDI); 2,4-hexahydrotoluene diisocyanate; 2,6-hexahydrotoluene diisocyanate; 1,2-, 1,3-, and 1,4-phenylene diisocyanate; aromatic aliphatic isocyanate, such as 1,2-, 1,3-, and 1,4-xylene diisocyanate; meta-tetramethylxylene diisocyanate (m-TMXDI); para-tetramethylxylene diisocyanate (p-TMXDI); trimerized isocyanurate of any polyisocyanate, such as isocyanurate of toluene diisocyanate, trimer of diphenylmethane diisocyanate, trimer of tetramethylxylene diisocyanate, isocyanurate of hexamethylene diisocyanate, isocyanurate of isophorone diisocyanate, and mixtures thereof; dimerized uretdione of any polyisocyanate, such as uretdione of toluene diisocyanate, uretdione of hexamethylene diisocyanate, and mixtures thereof; modified polyisocyanate derived from the above isocyanates and polyisocyanates; and mixtures thereof.

Examples of saturated diisocyanates that can be used with the present invention include, but are not limited to, ethylene diisocyanate; propylene-1,2-diisocyanate; tetramethylene diisocyanate; tetramethylene-1,4-diisocyanate; 1,6-hexamethylene-diisocyanate (HDI); octamethylene diisocyanate; decamethylene diisocyanate; 2,2,4-trimethylhexamethylene diisocyanate; 2,4,4-trimethylhexamethylene diisocyanate; dodecane-1,12-diisocyanate; cyclobutane-1,3-diisocyanate; cyclohexane-1,2-diisocyanate; cyclohexane-1,3-diisocyanate; cyclohexane-1,4-diisocyanate; methyl-cyclohexylene diisocyanate (HTDI); 2,4-methylcyclohexane diisocyanate; 2,6-methylcyclohexane diisocyanate; 4,4'-dicyclohexyl diisocyanate; 2,4'-dicyclohexyl diisocyanate; 1,3,5-cyclohexane triisocyanate; isocyanatomethylcyclohexane isocyanate; 1-isocyanato-3,3,5-trimethyl-5-isocyanatomethylcyclohexane; isocyanatoethylcyclohexane isocyanate; bis(isocyanatomethyl)-cyclohexane diisocyanate; 4,4'-bis(isocyanatomethyl)dicyclohexane; 2,4'-bis(isocyanatomethyl)dicyclohexane; isophorone diisocyanate (IPDI); triisocyanate of HDI; triisocyanate of 2,2,4-trimethyl-1,6-hexane diisocyanate (TMDI); 4,4'-dicyclohexylmethane diisocyanate (H_{12} MDI); 2,4-hexahydrotoluene diisocyanate; 2,6-hexahydrotoluene diisocyanate; and mix-

tures thereof. Aromatic aliphatic isocyanates may also be used to form light stable materials. Examples of such isocyanates include 1,2-, 1,3-, and 1,4-xylene diisocyanate; meta-tetramethylxylene diisocyanate (m-TMXDI); para-tetramethylxylene diisocyanate (p-TMXDI); trimerized isocyanurate of any polyisocyanate, such as isocyanurate of toluene diisocyanate, trimer of diphenylmethane diisocyanate, trimer of tetramethylxylene diisocyanate, isocyanurate of hexamethylene diisocyanate, isocyanurate of isophorone diisocyanate, and mixtures thereof; dimerized uretdione of any polyisocyanate, such as uretdione of toluene diisocyanate, uretdione of hexamethylene diisocyanate, and mixtures thereof; modified polyisocyanate derived from the above isocyanates and polyisocyanates; and mixtures thereof. In addition, the aromatic aliphatic isocyanates may be mixed with any of the saturated isocyanates listed above for the purposes of this invention.

The number of unreacted NCO groups in the polyurea prepolymer of isocyanate and polyether amine may be varied to control such factors as the speed of the reaction, the resultant hardness of the composition, and the like. For instance, the number of unreacted NCO groups in the polyurea prepolymer of isocyanate and polyether amine may be less than about 14 percent. In one embodiment, the polyurea prepolymer has from about 5 percent to about 11 percent unreacted NCO groups, and even more preferably has from about 6 to about 9.5 percent unreacted NCO groups. In one embodiment, the percentage of unreacted NCO groups is about 3 percent to about 9 percent. Alternatively, the percentage of unreacted NCO groups in the polyurea prepolymer may be about 7.5 percent or less, and more preferably, about 7 percent or less. In another embodiment, the unreacted NCO content is from about 2.5 percent to about 7.5 percent, and more preferably from about 4 percent to about 6.5 percent.

When formed, polyurea prepolymers may contain about 10 percent to about 20 percent by weight of the prepolymer of free isocyanate monomer. Thus, in one embodiment, the polyurea prepolymer may be stripped of the free isocyanate monomer. For example, after stripping, the prepolymer may contain about 1 percent or less free isocyanate monomer. In another embodiment, the prepolymer contains about 0.5 percent by weight or less of free isocyanate monomer.

The polyether amine may be blended with additional polyols to formulate copolymers that are reacted with excess isocyanate to form the polyurea prepolymer. In one embodiment, less than about 30 percent polyol by weight of the copolymer is blended with the saturated polyether amine. In another embodiment, less than about 20 percent polyol by weight of the copolymer, preferably less than about 15 percent by weight of the copolymer, is blended with the polyether amine. The polyols listed above with respect to the polyurethane prepolymer, e.g., polyether polyols, polycaprolactone polyols, polyester polyols, polycarbonate polyols, hydrocarbon polyols, other polyols, and mixtures thereof, are also suitable for blending with the polyether amine. The molecular weight of these polymers may be from about 200 to about 4000, but also may be from about 1000 to about 3000, and more preferably are from about 1500 to about 2500.

The polyurea composition can be formed by crosslinking the polyurea prepolymer with a single curing agent or a blend of curing agents. The curing agent of the invention is preferably an amine-terminated curing agent, more preferably a secondary diamine curing agent so that the composition contains only urea linkages. In one embodiment, the amine-terminated curing agent may have a molecular weight of about 64 or greater. In another embodiment, the molecular weight of the amine-curing agent is about 2000 or less. As

discussed above, certain amine-terminated curing agents may be modified with a compatible amine-terminated freezing point depressing agent or mixture of compatible freezing point depressing agents.

Suitable amine-terminated curing agents include, but are not limited to, ethylene diamine; hexamethylene diamine; 1-methyl-2,6-cyclohexyl diamine; tetrahydroxypropylene ethylene diamine; 2,2,4- and 2,4,4-trimethyl-1,6-hexanediamine; 4,4'-bis-(sec-butylamino)-dicyclohexylmethane; 1,4-bis-(sec-butylamino)-cyclohexane; 1,2-bis-(sec-butylamino)-cyclohexane; derivatives of 4,4'-bis-(sec-butylamino)-dicyclohexylmethane; 4,4'-dicyclohexylmethane diamine; 1,4-cyclohexane-bis-(methylamine); 1,3-cyclohexane-bis-(methylamine); diethylene glycol di-(aminopropyl)ether; 2-methylpentamethylene-diamine; diaminocyclohexane; diethylene triamine; triethylene tetramine; tetraethylene pentamine; propylene diamine; 1,3-diaminopropane; dimethylamino propylamine; diethylamino propylamine; dipropylene triamine; imido-bis-propylamine; monoethanolamine, diethanolamine; triethanolamine; monoisopropanolamine, diisopropanolamine; isophoronediamine; 4,4'-methylenebis-(2-chloroaniline); 3,5-dimethylthio-2,4-toluenediamine; 3,5-dimethylthio-2,6-toluenediamine; 3,5-diethylthio-2,4-toluenediamine; 3,5-diethylthio-2,6-toluenediamine; 4,4'-bis-(sec-butylamino)-diphenylmethane and derivatives thereof; 1,4-bis-(sec-butylamino)-benzene; 1,2-bis-(sec-butylamino)-benzene; N,N'-dialkylamino-diphenylmethane; N,N',N'-tetrakis(2-hydroxypropyl)ethylene diamine; trimethyleneglycol-di-p-aminobenzoate; polytetramethyleneoxide-di-p-aminobenzoate; 4,4'-methylenebis-(3-chloro-2,6-diethylaniline); 4,4'-methylenebis-(2,6-diethylaniline); meta-phenylenediamine; paraphenylenediamine; and mixtures thereof. In one embodiment, the amine-terminated curing agent is 4,4'-bis-(sec-butylamino)-dicyclohexylmethane.

Suitable saturated amine-terminated curing agents include, but are not limited to, ethylene diamine; hexamethylene diamine; 1-methyl-2,6-cyclohexyl diamine; tetrahydroxypropylene ethylene diamine; 2,2,4- and 2,4,4-trimethyl-1,6-hexanediamine; 4,4'-bis-(sec-butylamino)-dicyclohexylmethane; 1,4-bis-(sec-butylamino)-cyclohexane; 1,2-bis-(sec-butylamino)-cyclohexane; derivatives of 4,4'-bis-(sec-butylamino)-dicyclohexylmethane; 4,4'-dicyclohexylmethane diamine; 4,4'-methylenebis-(2,6-diethylaminocyclohexane); 1,4-cyclohexane-bis-(methylamine); 1,3-cyclohexane-bis-(methylamine); diethylene glycol di-(aminopropyl)ether; 2-methylpentamethylene-diamine; diaminocyclohexane; diethylene triamine; triethylene tetramine; tetraethylene pentamine; propylene diamine; 1,3-diaminopropane; dimethylamino propylamine; diethylamino propylamine; imido-bis-propylamine; monoethanolamine, diethanolamine; triethanolamine; monoisopropanolamine, diisopropanolamine; isophoronediamine; triisopropanolamine; and mixtures thereof. In addition, any of the polyether amines listed above may be used as curing agents to react with the polyurea prepolymers.

Suitable catalysts include, but are not limited to bismuth catalyst, oleic acid, triethylenediamine (DABCO®-33LV), di-butyltin dilaurate (DABCO®-T12) and acetic acid. The most preferred catalyst is di-butyltin dilaurate (DABCO®-T12). DABCO® materials are manufactured by Air Products and Chemicals, Inc.

Thermoplastic materials may be blended with other thermoplastic materials, but thermosetting materials are difficult if not impossible to blend homogeneously after the thermosetting materials are formed. Preferably, the saturated polyurethane comprises from about 1% to about 100%, more

preferably from about 10% to about 75% of the cover composition and/or the intermediate layer composition. About 90% to about 10%, more preferably from about 90% to about 25% of the cover and/or the intermediate layer composition is comprised of one or more other polymers and/or other materials as described below. Such polymers include, but are not limited to polyurethane/polyurea ionomers, polyurethanes or polyureas, epoxy resins, polyethylenes, polyamides and polyesters, polycarbonates and polyacrylin. Unless otherwise stated herein, all percentages are given in percent by weight of the total composition of the golf ball layer in question.

Polyurethane prepolymers are produced by combining at least one polyol, such as a polyether, polycaprolactone, polycarbonate or a polyester, and at least one isocyanate. Thermosetting polyurethanes are obtained by curing at least one polyurethane prepolymer with a curing agent selected from a polyamine, triol or tetraol. Thermoplastic polyurethanes are obtained by curing at least one polyurethane prepolymer with a diol curing agent. The choice of the curatives is critical because some urethane elastomers that are cured with a diol and/or blends of diols do not produce urethane elastomers with the impact resistance required in a golf ball cover. Blending the polyamine curatives with diol cured urethane elastomeric formulations leads to the production of thermoset urethanes with improved impact and cut resistance.

Thermoplastic polyurethanes may be blended with suitable materials to produce a thermoplastic end product. Examples of such additional materials may include ionomers such as the SURLYN®, ESCOR® and IOTEK® copolymers described above.

Other suitable materials which may be combined with the saturated polyurethanes in forming the cover and/or intermediate layer(s) of the golf balls of the invention include ionic or non-ionic polyurethanes and polyureas, epoxy resins, polyethylenes, polyamides and polyesters. For example, the cover and/or intermediate layer may be formed from a blend of at least one saturated polyurethane and thermoplastic or thermoset ionic and non-ionic urethanes and polyurethanes, cationic urethane ionomers and urethane epoxies, ionic and non-ionic polyureas and blends thereof. Examples of suitable urethane ionomers are disclosed in U.S. Pat. No. 5,692,974 entitled "Golf Ball Covers", the disclosure of which is hereby incorporated by reference in its entirety. Other examples of suitable polyurethanes are described in U.S. Pat. No. 5,334,673. Examples of appropriate polyureas are discussed in U.S. Pat. No. 5,484,870 and examples of suitable polyurethanes cured with epoxy group containing curing agents are disclosed in U.S. Pat. No. 5,908,358, the disclosures of which are hereby incorporated herein by reference in their entirety.

A variety of conventional components can be added to the cover compositions of the present invention. These include, but are not limited to, white pigment such as TiO₂, ZnO, optical brighteners, surfactants, processing aids, foaming agents, density-controlling fillers, UV stabilizers and light stabilizers. Saturated polyurethanes are resistant to discoloration. However, they are not immune to deterioration in their mechanical properties upon weathering. Addition of UV absorbers and light stabilizers therefore helps to maintain the tensile strength and elongation of the saturated polyurethane elastomers. Suitable UV absorbers and light stabilizers include TINUVIN® 328, TINUVIN® 213, TINUVIN® 765, TINUVIN® 770 and TINUVIN® 622. The preferred UV absorber is TINUVIN® 328, and the preferred light stabilizer is TINUVIN® 765. TINUVIN® products are available from Ciba-Geigy. Dyes, as well as optical brighteners and fluorescent pigments may also be included in the golf ball covers produced with polymers formed according to the present

invention. Such additional ingredients may be added in any amounts that will achieve their desired purpose.

Any method known to one of ordinary skill in the art may be used to polyurethanes of the present invention. One commonly employed method, known in the art as a one-shot method, involves concurrent mixing of the polyisocyanate, polyol, and curing agent. This method results in a mixture that is inhomogenous (more random) and affords the manufacturer less control over the molecular structure of the resultant composition. A preferred method of mixing is known as a prepolymer method. In this method, the polyisocyanate and the polyol are mixed separately prior to addition of the curing agent. This method affords a more homogeneous mixture resulting in a more consistent polymer composition. Other methods suitable for forming the layers of the present invention include reaction injection molding ("RIM"), liquid injection molding ("LIM"), and pre-reacting the components to form an injection moldable thermoplastic polyurethane and then injection molding, all of which are known to one of ordinary skill in the art.

Additional components which can be added to the polyurethane composition include UV stabilizers and other dyes, as well as optical brighteners and fluorescent pigments and dyes. Such additional ingredients may be added in any amounts that will achieve their desired purpose. It has been found by the present invention that the use of a castable, reactive material, which is applied in a fluid form, makes it possible to obtain very thin outer cover layers on golf balls. Specifically, it has been found that castable, reactive liquids, which react to form a urethane elastomer material, provide desirable very thin outer cover layers.

The castable, reactive liquid employed to form the urethane elastomer material can be applied over the core using a variety of application techniques such as spraying, dipping, spin coating, or flow coating methods which are well known in the art. An example of a suitable coating technique is that which is disclosed in U.S. Pat. No. 5,733,428, the disclosure of which is hereby incorporated by reference in its entirety.

The outer cover is preferably formed around the inner cover by mixing and introducing the material in the mold halves. It is important that the viscosity be measured over time, so that the subsequent steps of filling each mold half, introducing the core into one half and closing the mold can be properly timed for accomplishing centering of the core cover halves fusion and achieving overall uniformity. Suitable viscosity range of the curing urethane mix for introducing cores into the mold halves is determined to be approximately between about 2,000 cP and about 30,000 cP, with the preferred range of about 8,000 cP to about 15,000 cP.

To start the cover formation, mixing of the prepolymer and curative is accomplished in motorized mixer including mixing head by feeding through lines metered amounts of curative and prepolymer. Top preheated mold halves are filled and placed in fixture units using centering pins moving into holes in each mold. At a later time, a bottom mold half or a series of bottom mold halves have similar mixture amounts introduced into the cavity. After the reacting materials have resided in top mold halves for about 40 to about 80 seconds, a core is lowered at a controlled speed into the gelling reacting mixture.

A ball cup holds the ball core through reduced pressure (or partial vacuum). Upon location of the coated core in the halves of the mold after gelling for about 40 to about 80 seconds, the vacuum is released allowing core to be released. The mold halves, with core and solidified cover half thereon, are removed from the centering fixture unit, inverted and mated with other mold halves which, at an appropriate time

earlier, have had a selected quantity of reacting polyurethane prepolymer and curing agent introduced therein to commence gelling.

Similarly, U.S. Pat. No. 5,006,297 to Brown et al. and U.S. Pat. No. 5,334,673 to Wu both also disclose suitable molding techniques which may be utilized to apply the castable reactive liquids employed in the present invention. Further, U.S. Pat. Nos. 6,180,040 and 6,180,722 disclose methods of preparing dual core golf balls. The disclosures of these patents are hereby incorporated by reference in their entirety. However, the method of the invention is not limited to the use of these techniques.

Depending on the desired properties, balls prepared according to the invention can exhibit substantially the same or higher resilience, or coefficient of restitution ("COR"), with a decrease in compression or modulus, compared to balls of conventional construction. Additionally, balls prepared according to the invention can also exhibit substantially higher resilience, or COR, without an increase in compression, compared to balls of conventional construction. Another measure of this resilience is the "loss tangent," or $\tan \delta$, which is obtained when measuring the dynamic stiffness of an object. Loss tangent and terminology relating to such dynamic properties is typically described according to ASTM D4092-90. Thus, a lower loss tangent indicates a higher resiliency, thereby indicating a higher rebound capacity. Low loss tangent indicates that most of the energy imparted to a golf ball from the club is converted to dynamic energy, i.e., launch velocity and resulting longer distance. The rigidity or compressive stiffness of a golf ball may be measured, for example, by the dynamic stiffness. A higher dynamic stiffness indicates a higher compressive stiffness. To produce golf balls having a desirable compressive stiffness, the dynamic stiffness of the crosslinked reaction product material should be less than about 50,000 N/m at -50°C . Preferably, the dynamic stiffness should be between about 10,000 and 40,000 N/m at -50°C ., more preferably, the dynamic stiffness should be between about 20,000 and 30,000 N/m at -50°C .

The molding process and composition of golf ball portions typically results in a gradient of material properties. Methods employed in the prior art generally exploit hardness to quantify these gradients. Hardness is a qualitative measure of static modulus and does not represent the modulus of the material at the deformation rates associated with golf ball use, i.e., impact by a club. As is well known to one skilled in the art of polymer science, the time-temperature superposition principle may be used to emulate alternative deformation rates. For golf ball portions including polybutadiene, a 1-Hz oscillation at temperatures between 0°C . and -50°C . are believed to be qualitatively equivalent to golf ball impact rates. Therefore, measurement of loss tangent and dynamic stiffness at 0°C . to -50°C . may be used to accurately anticipate golf ball performance, preferably at temperatures between about -20°C . and -50°C .

In another embodiment of the present invention, a golf ball of the present invention is substantially spherical and has a cover with a plurality of dimples formed on the outer surface thereof.

U.S. application Ser. No. 10/230,015, now U.S. Publication No. 2003/0114565, and U.S. application Ser. No. 10/108,793, now U.S. Publication No. 2003/0050373, which are incorporated by reference herein in their entirety, discuss soft, high resilient ionomers, which are preferably from neutralizing the acid copolymer(s) of at least one E/X/Y copolymer, where E is ethylene, X is the α,β -ethylenically unsaturated carboxylic acid, and Y is a softening co-monomer. X is preferably present in 2-30 (preferably 4-20, most preferably 5-15)

wt. % of the polymer, and Y is preferably present in 17-40 (preferably 20-40, and more preferably 24-35) wt. % of the polymer. Preferably, the melt index (MI) of the base resin is at least 20, or at least 40, more preferably, at least 75 and most preferably at least 150. Particular soft, resilient ionomers included in this invention are partially neutralized ethylene/(meth) acrylic acid/butyl(meth)acrylate copolymers having an MI and level of neutralization that results in a melt processible polymer that has useful physical properties. The copolymers are at least partially neutralized. Preferably at least 40, or, more preferably at least 55, even more preferably about 70, and most preferably about 80 of the acid moiety of the acid copolymer is neutralized by one or more alkali metal, transition metal, or alkaline earth metal cations. Cations useful in making the ionomers of this invention comprise lithium, sodium, potassium, magnesium, calcium, barium, or zinc, or a combination of such cations.

The invention also relates to a "modified" soft, resilient thermoplastic ionomer that comprises a melt blend of (a) the acid copolymers or the melt processible ionomers made therefrom as described above and (b) one or more organic acid(s) or salt(s) thereof, wherein greater than 80%, preferably greater than 90% of all the acid of (a) and of (b) is neutralized. Preferably, 100% of all the acid of (a) and (b) is neutralized by a cation source. Preferably, an amount of cation source in excess of the amount required to neutralize 100% of the acid in (a) and (b) is used to neutralize the acid in (a) and (b). Blends with fatty acids or fatty acid salts are preferred.

The organic acids or salts thereof are added in an amount sufficient to enhance the resilience of the copolymer. Preferably, the organic acids or salts thereof are added in an amount sufficient to substantially remove remaining ethylene crystallinity of the copolymer.

Preferably, the organic acids or salts are added in an amount of at least about 5% (weight basis) of the total amount of copolymer and organic acid(s). More preferably, the organic acids or salts thereof are added in an amount of at least about 15%, even more preferably at least about 20%. Preferably, the organic acid(s) are added in an amount up to about 50% (weight basis) based on the total amount of copolymer and organic acid. More preferably, the organic acids or salts thereof are added in an amount of up to about 40%, more preferably, up to about 35%. The non-volatile, non-migratory organic acids preferably are one or more aliphatic, mono-functional organic acids or salts thereof as described below, particularly one or more aliphatic, mono-functional, saturated or unsaturated organic acids having less than 36 carbon atoms or salts of the organic acids, preferably stearic acid or oleic acid. Fatty acids or fatty acid salts are most preferred.

Processes for fatty acid (salt) modifications are known in the art. Particularly, the modified highly-neutralized soft, resilient acid copolymer ionomers of this invention can be produced by:

(a) melt-blending (1) ethylene, α,β -ethylenically unsaturated C_{3-8} carboxylic acid copolymer(s) or melt-processible ionomer(s) thereof that have their crystallinity disrupted by addition of a softening monomer or other means with (2) sufficient non-volatile, non-migratory organic acids to substantially enhance the resilience and to disrupt (preferably remove) the remaining ethylene crystallinity, and then concurrently or subsequently

(b) adding a sufficient amount of a cation source to increase the level of neutralization of all the acid moieties (including those in the acid copolymer and in the organic acid if the non-volatile, non-migratory organic acid is an organic acid) to the desired level.

The weight ratio of X to Y in the composition is at least about 1:20. Preferably, the weight ratio of X to Y is at least about 1:15, more preferably, at least about 1:10. Furthermore, the weight ratio of X to Y is up to about 1:1.67, more preferably up to about 1:2. Most preferably, the weight ratio of X to Y in the composition is up to about 1:2.2.

The acid copolymers used in the present invention to make the ionomers are preferably 'direct' acid copolymers (containing high levels of softening monomers). As noted above, the copolymers are at least partially neutralized, preferably at least about 40% of X in the composition is neutralized. More preferably, at least about 55% of X is neutralized. Even more preferably, at least about 70, and most preferably, at least about 80% of X is neutralized. In the event that the copolymer is highly neutralized (e.g., to at least 45%, preferably 50%, 55%, 70%, or 80%, of acid moiety), the MI of the acid copolymer should be sufficiently high so that the resulting neutralized resin has a measurable MI in accord with ASTM D-1238, condition E, at 190° C., using a 2160 gram weight. Preferably this resulting MI will be at least 0.1, preferably at least 0.5, and more preferably 1.0 or greater. Preferably, for highly neutralized acid copolymer, the MI of the acid copolymer base resin is at least 20, or at least 40, at least 75, and more preferably at least 150.

The acid copolymers preferably comprise alpha olefin, particularly ethylene, C₃₋₈. α,β -ethylenically unsaturated carboxylic acid, particularly acrylic and methacrylic acid, and softening monomers, selected from alkyl acrylate, and alkyl methacrylate, wherein the alkyl groups have from 1-8 carbon atoms, copolymers. By "softening," it is meant that the crystallinity is disrupted (the polymer is made less crystalline). While the alpha olefin can be a C₂-C₄ alpha olefin, ethylene is most preferred for use in the present invention. Accordingly, it is described and illustrated herein in terms of ethylene as the alpha olefin.

The acid copolymers, when the alpha olefin is ethylene, can be described as E/X/Y copolymers where E is ethylene, X is the α,β -ethylenically unsaturated carboxylic acid, and Y is a softening comonomer; X is preferably present in 2-30 (preferably 4-20, most preferably 5-15) wt. % of the polymer, and Y is preferably present in 17-40 (preferably 20-40, most preferably 24-35) wt. % of the polymer.

The ethylene-acid copolymers with high levels of acid (X) are difficult to prepare in continuous polymerizers because of monomer-polymer phase separation. This difficulty can be avoided however by use of "co-solvent technology" as described in U.S. Pat. No. 5,028,674, or by employing somewhat higher pressures than those which copolymers with lower acid can be prepared.

Specific acid-copolymers include ethylene/(meth) acrylic acid/n-butyl(meth)acrylate, ethylene/(meth) acrylic acid/isobutyl(meth)acrylate, ethylene/(meth) acrylic acid/methyl(meth)acrylate, and ethylene/(meth) acrylic acid/ethyl(meth) acrylate terpolymers.

The organic acids employed are aliphatic, mono-functional (saturated, unsaturated, or multi-unsaturated) organic acids, particularly those having fewer than 36 carbon atoms. Also salts of these organic acids may be employed. Fatty acids or fatty acid salts are preferred. The salts may be any of a wide variety, particularly including the barium, lithium, sodium, zinc, bismuth, potassium, strontium, magnesium or calcium salts of the organic acids. Particular organic acids useful in the present invention include caproic acid, caprylic acid, capric acid, lauric acid, stearic acid, behenic acid, erucic acid, oleic acid, and linoleic acid.

The optional filler component is chosen to impart additional density to blends of the previously described compo-

nents, the selection being dependent upon the different parts (e.g., cover, mantle, core, center, intermediate layers in a multilayered core or ball) and the type of golf ball desired (e.g., one-piece, two-piece, three-piece or multiple-piece ball), as will be more fully detailed below.

Generally, the filler will be inorganic having a density greater than about 4 g/cm³, preferably greater than 5 g/cm³, and will be present in amounts between 0 to about 60 wt. % based on the total weight of the composition. Examples of useful fillers include zinc oxide, barium sulfate, lead silicate and tungsten carbide, as well as the other well-known fillers used in golf balls. It is preferred that the filler materials be non-reactive or almost non-reactive and not stiffen or raise the compression nor reduce the coefficient of restitution significantly.

Additional optional additives useful in the practice of the subject invention include acid copolymer wax (e.g., Allied wax AC 143 believed to be an ethylene/16-18% acrylic acid copolymer with a number average molecular weight of 2,040), which assist in preventing reaction between the filler materials (e.g., ZnO) and the acid moiety in the ethylene copolymer. Other optional additives include TiO₂, which is used as a whitening agent; optical brighteners; surfactants; processing aids; etc.

Ionomers may be blended with conventional ionomeric copolymers (di-, ter-, etc.), using well-known techniques, to manipulate product properties as desired. The blends would still exhibit lower hardness and higher resilience when compared with blends based on conventional ionomers.

Also, ionomers can be blended with non-ionic thermoplastic resins to manipulate product properties. The non-ionic thermoplastic resins would, by way of non-limiting illustrative examples, include thermoplastic elastomers, such as polyurethane, poly-ether-ester, poly-amide-ether, polyether-urea, PEBAX® (a family of block copolymers based on poly-ether-block-amide, commercially supplied by Atochem), styrene-butadiene-styrene (SBS) block copolymers, styrene (ethylene-butylene)-styrene block copolymers, etc., poly amide (oligomeric and polymeric), polyesters, polyolefins including PE, PP, E/P copolymers, etc., ethylene copolymers with various comonomers, such as vinyl acetate, (meth)acrylates, (meth)acrylic acid, epoxy-functionalized monomer, CO, etc., functionalized polymers with maleic anhydride grafting, epoxidization etc., elastomers, such as EPDM, metallocene catalyzed PE and copolymer, ground up powders of the thermoset elastomers, etc. Such thermoplastic blends comprise about 1% to about 99% by weight of a first thermoplastic and about 99% to about 1% by weight of a second thermoplastic.

Additionally, the compositions of U.S. application Ser. No. 10/269,341, now U.S. Publication No. 2003/0130434, and U.S. Pat. No. 6,653,382, both of which are incorporated herein in their entirety, discuss compositions having high COR when formed into solid spheres.

The thermoplastic composition of this invention comprises a polymer which, when formed into a sphere that is 1.50 to 1.54 inches in diameter, has a coefficient of restitution (COR) when measured by firing the sphere at an initial velocity of 125 feet/second against a steel plate positioned 3 feet from the point where initial velocity and rebound velocity are determined and by dividing the rebound velocity from the plate by the initial velocity and an Atti compression of no more than 100.

The thermoplastic composition of this invention preferably comprises (a) aliphatic, mono-functional organic acid(s) having fewer than 36 carbon atoms; and (b) ethylene, C₃ to C₈ α,β -ethylenically unsaturated carboxylic acid copolymer(s)

and ionomer(s) thereof, wherein greater than 90%, preferably near 100%, and more preferably 100% of all the acid of (a) and (b) are neutralized.

The thermoplastic composition preferably comprises melt-processible, highly-neutralized (greater than 90%, preferably near 100%, and more preferably 100%) polymer of (1) ethylene, C₃ to C₈ α,β -ethylenically unsaturated carboxylic acid copolymers that have their crystallinity disrupted by addition of a softening monomer or other means such as high acid levels, and (2) non-volatile, non-migratory agents such as organic acids (or salts) selected for their ability to substantially or totally suppress any remaining ethylene crystallinity. Agents other than organic acids (or salts) may be used.

It has been found that, by modifying an acid copolymer or ionomer with a sufficient amount of specific organic acids (or salts thereof); it is possible to highly neutralize the acid copolymer without losing processibility or properties such as elongation and toughness. The organic acids employed in the present invention are aliphatic, mono-functional, saturated or unsaturated organic acids, particularly those having fewer than 36 carbon atoms, and particularly those that are non-volatile and non-migratory and exhibit ionic array plasticizing and ethylene crystallinity suppression properties.

With the addition of sufficient organic acid, greater than 90%, nearly 100%, and preferably 100% of the acid moieties in the acid copolymer from which the ionomer is made can be neutralized without losing the processibility and properties of elongation and toughness.

The melt-processible, highly-neutralized acid copolymer ionomer can be produced by the following:

(a) melt-blending (1) ethylene α,β -ethylenically unsaturated C₃₋₈ carboxylic acid copolymer(s) or melt-processible ionomer(s) thereof (ionomers that are not neutralized to the level that they have become intractable, that is not melt-processible) with (1) one or more aliphatic, mono-functional, saturated or unsaturated organic acids having fewer than 36 carbon atoms or salts of the organic acids, and then concurrently or subsequently

(b) adding a sufficient amount of a cation source to increase the level of neutralization all the acid moieties (including those in the acid copolymer and in the organic acid) to greater than 90%, preferably near 100%, more preferably to 100%.

Preferably, highly-neutralized thermoplastics of the invention can be made by:

(a) melt-blending (1) ethylene, α,β -ethylenically unsaturated C₃₋₈ carboxylic acid copolymer(s) or melt-processible ionomer(s) thereof that have their crystallinity disrupted by addition of a softening monomer or other means with (2) sufficient non-volatile, non-migratory agents to substantially remove the remaining ethylene crystallinity, and then concurrently or subsequently

(b) adding a sufficient amount of a cation source to increase the level of neutralization all the acid moieties (including those in the acid copolymer and in the organic acid if the non-volatile, non-migratory agent is an organic acid) to greater than 90%, preferably near 100%, more preferably to 100%.

The acid copolymers used in the present invention to make the ionomers are preferably 'direct' acid copolymers. They are preferably alpha olefin, particularly ethylene, C₃₋₈ α,β -ethylenically unsaturated carboxylic acid, particularly acrylic and methacrylic acid, copolymers. They may optionally contain a third softening monomer. By "softening," it is meant that the crystallinity is disrupted (the polymer is made less crystalline). Suitable "softening" comonomers are monomers selected from alkyl acrylate, and alkyl methacrylate, wherein the alkyl groups have from 1-8 carbon atoms.

The acid copolymers, when the alpha olefin is ethylene, can be described as E/X/Y copolymers where E is ethylene, X is the α,β -ethylenically unsaturated carboxylic acid, and Y is a softening comonomer. X is preferably present in 3-30 (preferably 4-25, most preferably 5-20) wt. % of the polymer, and Y is preferably present in 0-30 (alternatively 3-25 or 10-23) wt. % of the polymer.

Spheres were prepared using fully neutralized ionomers A and B.

TABLE I

Sample	Resin Type (%)	Acid Type (%)	Cation (% neut*)	M.I. (g/10 min)
1A	A(60)	Oleic (40)	Mg (100)	1.0
2B	A(60)	Oleic (40)	Mg (105)*	0.9
3C	B(60)	Oleic (40)	Mg (100)	0.9
4D	B(60)	Oleic (40)	Mg (105)*	0.9
5E	B(60)	Stearic (40)	Mg (100)	0.85

A - 76.9% ethylene, 14.8% normal butyl acrylate, 8.3% acrylic acid

B - 75% ethylene, 14.9% normal butyl acrylate, 10.1% acrylic acid

*indicates that cation was sufficient to neutralize 105% of all acid in resin and organic acid.

These compositions were molded into 1.53-inch spheres for which data is presented in the following table.

TABLE II

Sample	Atti Compression	COR @ 125 ft/s
1A	75	0.826
2B	75	0.826
3C	78	0.837
4D	76	0.837
5E	97	0.807

Further testing of commercially available highly neutralized polymers HNP1 and HNP2 had the following properties.

TABLE III

	Material Properties	
	HNP1	HNP2
Specific Gravity (g/cm ³)	0.966	0.974
Melt Flow, 190° C., 10-kg load	0.65	1.0
Shore D Flex Bar (40 hr)	47.0	46.0
Shore D Flex Bar (2 week)	51.0	48.0
Flex Modulus, psi (40 hr)	25,800	16,100
Flex Modulus, psi (2 week)	39,900	21,000
DSC Melting Point (° C.)	61.0	61/101
Moisture (ppm)	1500	4500
Weight % Mg	2.65	2.96

TABLE IV

Material	Solid Sphere Data				
	HNP1	HNP2	HNP2a	HNP1a	HNP1a/HNP2a (50:50 blend)
Spec. Grav. (g/cm ³)	0.954	0.959	1.153	1.146	1.148
Filler	None	None	Tungsten	Tungsten	Tungsten
Compression	107	83	86	62	72
COR	0.827	0.853	0.844	0.806	0.822
Shore D	51	47	49	42	45
Shore C			79	72	75

These materials are exemplary examples of the preferred center and/or core layer compositions of the present invention. They may also be used as a cover layer herein.

The golf ball components of the present invention, in particular the core (center and/or outer core layers) may be formed from a co-polymer of ethylene and an α,β -unsaturated carboxylic acid. In another embodiment, they may be formed from a terpolymer of ethylene, an α,β -unsaturated carboxylic acid, and an n-alkyl acrylate. Preferably, the α,β -unsaturated carboxylic acid is acrylic acid or methacrylic acid. In a preferred embodiment, the n-alkyl acrylate is n-butyl acrylate. Further, in a preferred form, the co- or ter-polymer comprises a level of fatty acid salt greater than 5 phr of the base resin. The preferred fatty acid salt is magnesium oleate or magnesium stearate.

It is highly preferred that the carboxylic acid in the intermediate layer is 100% neutralized with metal ions. The metal ions used to neutralize the carboxylic acid may be any metal ion known in the art. Preferably, the metal ions comprise magnesium ions. If the material used in the intermediate layer is not 100% neutralized, the resultant resilience properties such as COR and initial velocity may not be sufficient to produce the improved initial velocity and distance properties of the present invention.

The golf ball components can comprise various levels of the three components of the co- or terpolymer as follows: from about 60 to about 90% ethylene, from about 8 to about 20% by weight of the α,β -unsaturated carboxylic acid, and from 0% to about 25% of the n-alkyl acrylate. The co- or terpolymer may also contain an amount of a fatty acid salt. The fatty acid salt preferably comprises magnesium oleate. These materials are commercially available from DuPont, under the tradename DuPont HPF®.

In one embodiment, the center and/or core layers (or other intermediate layers) comprises a copolymer of about 81% by weight ethylene and about 19% by weight acrylic acid, wherein 100% of the carboxylic acid groups are neutralized with magnesium ions. The copolymer also contains at least 5 phr of magnesium oleate. Material suitable for use as this layer is available from DuPont under the tradename DuPont HPF SEP 1313-4®.

In a second preferred embodiment, the center and/or core layers (or other intermediate layers) comprise a copolymer of about 85% by weight ethylene and about 15% by weight acrylic acid, wherein 100% of the acid groups are neutralized with magnesium ions. The copolymer also contains at least 5 phr of magnesium oleate. Material suitable for use as this layer is available from DuPont under the tradename DuPont HPF SEP 1313-3®.

In a third preferred embodiment, the center and/or core layers (or other intermediate layers) comprise a copolymer of about 88% by weight ethylene and about 12% by weight acrylic acid, wherein 100% of the acid groups are neutralized with magnesium ions. The copolymer also contains at least 5 phr of magnesium oleate. Material suitable for use as this layer is available from DuPont under the tradename DuPont HPF AD1027®.

In a further preferred embodiment, the center and/or core layers (or other intermediate layers) are adjusted to a target specific gravity to enable the ball to be balanced. For a 1.68-inch diameter golf ball having a ball weight of about 1.61 oz, the target specific gravity is about 1.125. It will be appreciated by one of ordinary skill in the art that the target specific gravity will vary based upon the size and weight of the golf ball. The specific gravity is adjusted to the desired target through the use of inorganic fillers. Preferred fillers used for compounding the inner layer to the desired specific gravity

include, but are not limited to, tungsten, zinc oxide, barium sulfate and titanium dioxide. Other suitable fillers, in particular nano or hybrid materials, include those described in U.S. Pat. No. 6,793,592 and U.S. application Ser. No. 10/037,987, which are incorporated herein, in their entirety, by reference thereto.

Some preferred golf ball layers formed from the above compositions were molded onto a golf ball center using DuPont HPF RX-85®, Dupont HPF SEP 1313-3®, or DuPont HPF SEP 1313-4®. 1) DuPont HPF RX-85®, a copolymer of about 88% ethylene and about 12% acrylic acid, wherein 100% of the acid groups are neutralized with magnesium ions. Further, the copolymer contains a fixed amount of magnesium oleate. This material was compounded to a specific gravity of about 1.125 using tungsten. The Shore D hardness of this material (as measured on the curved surface of the inner cover layer) was about 58 to about 60. 2) DuPont HPF SEP 1313-3®, a copolymer of about 85% ethylene and about 15% acrylic acid, wherein 100% of the acid groups are neutralized with magnesium ions. Further, the copolymer contains a fixed amount of magnesium oleate. This material was compounded to a specific gravity of about 1.125 using tungsten. The Shore D hardness of this material (as measured on the curved surface of the inner cover layer) was about 58-60. 3) DuPont HPF SEP 1313-4®, a copolymer of about 81% ethylene and about 19% acrylic acid, wherein 100% of the acid groups are neutralized with magnesium ions. Further, the copolymer contains a fixed amount of magnesium oleate. This material was compounded to a specific gravity of about 1.125 using tungsten. The Shore D hardness of this material (as measured on the curved surface of the inner cover layer) was about 58-60.

The centers/cores/layers can also comprise various levels of the three components of the terpolymer as follows: from about 60% to 80% ethylene; from about 8% to 20% by weight of the α,β -unsaturated carboxylic acid; and from about 0% to 25% of the n-alkyl acrylate, preferably 5% to 25%. The terpolymer will also contain an amount of a fatty acid salt, preferably magnesium oleate. These materials are commercially available under the trade name DuPont® HPF™. In a preferred embodiment, a terpolymer suitable for the invention will comprise from about 75% to 80% by weight ethylene, from about 8% to 12% by weight of acrylic acid, and from about 8% to 17% by weight of n-butyl acrylate, wherein all of the carboxylic acid is neutralized with magnesium ions, and comprises at least 5 phr of magnesium oleate.

In another preferred embodiment, the cover layer will comprise a terpolymer of about 70% to 75% by weight ethylene, about 10.5% by weight acrylic acid, and about 15.5% to 16.5% by weight n-butyl acrylate. The acrylic acid groups are 100% neutralized with magnesium ions. The terpolymer will also contain an amount of magnesium oleate. Materials suitable for use as this layer are sold under the trade name DuPont® HPF™ AD 1027.

In yet another preferred embodiment, the centers/cores/layers comprise a copolymer comprising about 88% by weight of ethylene and about 12% by weight acrylic acid, with 100% of the acrylic acid neutralized by magnesium ions. The centers/cores/layers may also contain magnesium oleate. Material suitable for this embodiment was produced by DuPont as experimental product number SEP 1264-3. Preferably the centers/cores/layers are adjusted to a target specific gravity of 1.125 using inert fillers to adjust the density with minimal effect on the performance properties of the cover layer. Preferred fillers used for compounding the centers/

cores/layers to the desired specific gravity include but are not limited to tungsten, zinc oxide, barium sulfate, and titanium dioxide.

A first set of intermediate layers were molded onto cores using DuPont® HPF™ AD1027, which is a terpolymer of about 73% to 74% ethylene, about 10.5% acrylic acid, and about 15.5% to 16.5% n-butyl acrylate, wherein 100% of the acid groups are neutralized with magnesium ions. Further, the terpolymer contains a fixed amount of greater than 5 phr magnesium oleate. This material is compounded to a specific gravity of about 1.125 using barium sulfate and titanium dioxide. The Shore D hardness of this material (as measured on the curved surface of the inner cover layer) is about 58-60.

A second set of layers were molded onto each of the experimental cores using DuPont experimental HPF™ SEP 1264-3, which is a copolymer of about 88% ethylene and about 12% acrylic acid, wherein 100% of the acid groups are neutralized with magnesium ions. Further, the copolymer contains a fixed amount of at least 5 phr magnesium oleate. This material is compounded to a specific gravity of about 1.125 using zinc oxide. The Shore D hardness of this material (as measured on the curved surface of the inner cover layer) is about 61-64.

A first set of covers were molded onto each of the center/layer components using DuPont HPF™ 1000, which is a terpolymer of about 75% to 76% ethylene, about 8.5% acrylic acid, and about 15.5% to 16.5% n-butyl acrylate, wherein 100% of the acid groups are neutralized with magnesium ions. Further, the terpolymer contains a fixed amount of at least 5 phr of magnesium stearate. This material is compounded to a target specific gravity of about 1.125 using barium sulfate and titanium dioxide. The Shore D hardness of this material (as measured on the curved surface of the molded golf ball) is about 60-62.

In one embodiment, the formation of a golf ball starts with forming the center or inner core. The center, outer core, and the cover are formed by compression molding, by injection molding, or by casting. These methods of forming cores and covers of this type are well known in the art. The materials used for the inner and outer core, as well as the cover, are selected so that the desired playing characteristics of the ball are achieved. The inner and outer core materials have substantially different material properties so that there is a predetermined relationship between the inner and outer core materials, to achieve the desired playing characteristics of the ball.

In one embodiment, the inner core is formed of a first material having a first Shore D hardness, a first elastic modulus, a first specific gravity, and a first Bashore resilience. The outer core is formed of a second material having a second Shore D hardness, a second elastic modulus, a second specific gravity, and a second Bashore resilience. Preferably, the material property of the first material equals at least one selected from the group consisting of the first Shore D hardness differing from the second Shore D hardness by at least 10 points, the first elastic modulus differing from the second elastic modulus by at least 10%, the first specific gravity differing from the second specific gravity by at least 0.1, or a first Bashore resilience differing from the second Bashore resilience by at least 10%. It is more preferred that the first material have all of these material property relationships.

Moreover, it is preferred that the first material has the first Shore D hardness between about 30 and about 80, the first elastic modulus between about 5,000 psi and about 100,000 psi, the first specific gravity between about 0.8 and about 1.6, and the first Bashore resilience greater than 30%.

In another embodiment, the first Shore D hardness is less than the second Shore D hardness, the first elastic modulus is

less than the second elastic modulus, the first specific gravity is less than the second specific gravity, and the first Bashore resilience is less than the second Bashore resilience. In another embodiment, the first material properties are greater than the second material properties. The relationship between the first and second material properties depends on the desired playability characteristics.

Suitable inner and outer core materials include HNP's neutralized with organic fatty acids and salts thereof, metal cations, or a combination of both, thermosets, such as rubber, polybutadiene, polyisoprene; thermoplastics, such as ionomer resins, polyamides or polyesters; or thermoplastic elastomers. Suitable thermoplastic elastomers include PEBAX®, HYTREL®, thermoplastic urethane, and KRATON®, which are commercially available from Elf-Atochem, DuPont, BF Goodrich, and Shell, respectively. The inner and outer core materials can also be formed from a castable material. Suitable castable materials include, but are not limited to, urethane, urea, epoxy, diols, or curatives.

The cover is selected from conventional materials used as golf ball covers based on the desired performance characteristics. The cover may be comprised of one or more layers. Cover materials such as ionomer resins, blends of ionomer resins, thermoplastic or thermoset urethanes, and balata, can be used as known in the art and discussed above. In other embodiments, additional layers may be added to those mentioned above or the existing layers may be formed by multiple materials.

When the center is formed with a fluid-filled center, the center is formed first then an intermediate layer is molded around the center. Optionally a hollow intermediate sphere or envelope is formed first and then filled with the fluid. Conventional molding techniques can be used for this operation. Then the outer core and cover are formed thereon, as discussed above. The fluid within the center can be a wide variety of materials including air, water solutions, liquids, gels, foams, hot-melts, other fluid materials and combinations thereof. The fluid is varied to modify the performance parameters of the ball, such as the moment of inertia or the spin decay rate. Examples of suitable liquids include either solutions such as salt in water, corn syrup, salt in water and corn syrup, glycol and water or oils. The liquid can further include pastes, colloidal suspensions, such as clay, barytes, carbon black in water or other liquid, or salt in water/glycol mixtures. Examples of suitable gels include water gelatin gels, hydrogels, water/methyl cellulose gels and gels comprised of copolymer rubber based materials such a styrene-butadiene-styrene rubber and paraffinic and/or naphthenic oil. Examples of suitable melts include waxes and hot melts. Hot-melts are materials which at or about normal room temperatures are solid but at elevated temperatures become liquid. A high melting temperature is desirable since the liquid core is heated to high temperatures during the molding of the inner core, outer core, and the cover. The liquid can be a reactive liquid system, which combines to form a solid. Examples of suitable reactive liquids are silicate gels, agar gels, peroxide cured polyester resins, two part epoxy resin systems and peroxide cured liquid polybutadiene rubber compositions.

The "effective compression constant," which is designated EC, is the ratio of deflection of a 1.50 inch diameter sphere made of any single material used in the core under a 100 kg load that as represented by the formula $EC=F/d$, where, F is a 100 kg load; and d is the deflection in millimeters. If the sphere tested is only inner core center material, the effective compression constant for the center material alone is designated EC_{IC} . If the sphere tested is only outer core material, the effective compression constant for the outer core material

alone is designated EC_{OC} . The sum of the constants for the inner core EC_{IC} and outer core EC_{OC} is the constant EC_S . If the sphere tested is inner and outer core material, the core effective compression constant is designated EC_C . It is has been determined that very favorable cores are formed when their core effective compression constant EC_C is less than the sum of the effective compression constants of the inner core and outer core EC_S . It is recommended that the core effective compression constant EC_C is less than about 90% of the sum of the effective compression constants of the inner core and outer core EC_S . More preferably, the core effective compression constant EC_C is less than or equal to about 50% of the sum of the effective compression constants of the inner core and outer core EC_S . The ratios of the inner core material to outer core material and the geometry of the inner core to the outer core are selected to achieve these core effective compression constants.

The resultant golf balls typically have a coefficient of restitution of greater than about 0.7, preferably greater than about 0.75, and more preferably greater than about 0.78. The golf balls also typically have an Atti compression of at least about 40, preferably from about 50 to 120, and more preferably from about 60 to 100. The golf ball cured polybutadiene material typically has a hardness of at least about 15 Shore A, preferably between about 30 Shore A and 80 Shore D, more preferably between about 50 Shore A and 60 Shore D.

In addition to the HNP's neutralized with organic fatty acids and salts thereof, core compositions may comprise at least one rubber material having a resilience index of at least about 40. Preferably the resilience index is at least about 50. Polymers that produce resilient golf balls and, therefore, are suitable for the present invention, include but are not limited to CB23, CB22, commercially available from of Bayer Corp. of Orange, Tex., BR60, commercially available from Enichem of Italy, and 1207G, commercially available from Goodyear Corp. of Akron, Ohio.

Additionally, the unvulcanized rubber, such as polybutadiene, in golf balls prepared according to the invention typically has a Mooney viscosity of between about 40 and about 80, more preferably, between about 45 and about 65, and most preferably, between about 45 and about 55. Mooney viscosity is typically measured according to ASTM-D1646.

When golf balls are prepared according to the invention, they typically will have dimple coverage greater than about 60 percent, preferably greater than about 65 percent, and more preferably greater than about 75 percent. The flexural modulus of the cover on the golf balls, as measured by ASTM method D6272-98, Procedure B, is typically greater than about 500 psi, and is preferably from about 500 psi to 150,000 psi. As discussed herein, the outer cover layer is preferably formed from a relatively soft polyurethane material. In particular, the material of the outer cover layer should have a material hardness, as measured by ASTM-D2240, less than about 45 Shore D, preferably less than about 40 Shore D, more preferably between about 25 and about 40 Shore D, and most preferably between about 30 and about 40 Shore D. The casing preferably has a material hardness of less than about 70 Shore D, more preferably between about 30 and about 70 Shore D, and most preferably, between about 50 and about 65 Shore D.

In a preferred embodiment, the intermediate layer material hardness is between about 40 and about 70 Shore D and the outer cover layer material hardness is less than about 40 Shore D. In a more preferred embodiment, a ratio of the intermediate layer material hardness to the outer cover layer material hardness is greater than 1.5.

It should be understood, especially to one of ordinary skill in the art, that there is a fundamental difference between "material hardness" and "hardness, as measured directly on a golf ball." Material hardness is defined by the procedure set forth in ASTM-D2240 and generally involves measuring the hardness of a flat "slab" or "button" formed of the material of which the hardness is to be measured. Hardness, when measured directly on a golf ball (or other spherical surface) is a completely different measurement and, therefore, results in a different hardness value. This difference results from a number of factors including, but not limited to, ball construction (i.e., core type, number of core and/or cover layers, etc.), ball (or sphere) diameter, and the material composition of adjacent layers. It should also be understood that the two measurement techniques are not linearly related and, therefore, one hardness value cannot easily be correlated to the other.

In one embodiment, the core of the present invention has an Atti compression of between about 50 and about 90, more preferably, between about 60 and about 85, and most preferably, between about 65 and about 85. The overall outer diameter ("OD") of the core is less than about 1.590 inches, preferably, no greater than 1.580 inches, more preferably between about 1.540 inches and about 1.580 inches, and most preferably between about 1.525 inches to about 1.570 inches. The OD of the casing of the golf balls of the present invention is preferably between 1.580 inches and about 1.640 inches, more preferably between about 1.590 inches to about 1.630 inches, and most preferably between about 1.600 inches to about 1.630 inches.

The present multilayer golf ball can have an overall diameter of any size. Although the United States Golf Association ("USGA") specifications limit the minimum size of a competition golf ball to 1.680 inches. There is no specification as to the maximum diameter. Golf balls of any size, however, can be used for recreational play. The preferred diameter of the present golf balls is from about 1.680 inches to about 1.800 inches. The more preferred diameter is from about 1.680 inches to about 1.760 inches. The most preferred diameter is about 1.680 inches to about 1.740 inches.

The golf balls of the present invention may have a moment of inertia ("MOI") of about 70-95 $q \times \text{cm}^2$, preferably 75-93, more preferably about 76-90. If a low MOI golf ball is desired, the MOI should be <85 , more preferably <83 for a high MOI ball, the MOI should be >86 , more preferably >87 $q \cdot \text{cm}^2$. The MOI is typically measured on model number MOI-005-104 Moment of Inertia Instrument manufactured by Inertia Dynamics of Collinsville, Conn. The instrument is plugged into a PC for communication via a COMM port and is driven by MOI Instrument Software version #1.2.

U.S. Pat. Nos. 6,193,619; 6,207,784; and 6,221,960, and U.S. application Ser. No. 09/594,031, filed Jun. 15, 2000; Ser. No. 09/677,871, filed Oct. 3, 2000, and Ser. No. 09/447,652, filed Nov. 23, 1999, are incorporated in their entirety herein by express reference thereto.

The highly-neutralized polymers of the present invention may also be used in golf equipment, in particular, inserts for golf clubs, such as putters, irons, and woods, and in golf shoes and components thereof.

As yet another embodiment, the core comprises a reaction product that includes a cis-to-trans catalyst, a resilient polymer component having polybutadiene, a free radical source, and optionally, a crosslinking agent, a filler, or both. Preferably, the polybutadiene reaction product is used to form at least a portion of the core of the golf ball, and further discussion below relates to this embodiment for preparing the core. Preferably, the reaction product has a first dynamic stiffness measured at -50°C . that is less than about 130 percent of a

second dynamic stiffness measured at 0° C. More preferably, the first dynamic stiffness is less than about 125 percent of the second dynamic stiffness. Most preferably, the first dynamic stiffness is less than about 110 percent of the second dynamic stiffness.

The cis-to-trans conversion requires the presence of a cis-to-trans catalyst, such as an organosulfur or metal-containing organosulfur compound, a substituted or unsubstituted aromatic organic compound that does not contain sulfur or metal, an inorganic sulfide compound, an aromatic organometallic compound, or mixtures thereof. The cis-to-trans catalyst component may include one or more of the cis-to-trans catalysts described herein. For example, the cis-to-trans catalyst may be a blend of an organosulfur component and an inorganic sulfide component.

The preferred organosulfur components include 4,4'-diphenyl disulfide, 4,4'-ditolyl disulfide, or 2,2'-benzamido diphenyl disulfide, or a mixture thereof. An additional preferred organosulfur components include, but are not limited to, pentachlorothiophenol, zinc pentachlorothiophenol, non-metal salts of pentachlorothiophenol such as ammonium salt of pentachlorothiophenol magnesium pentachlorothiophenol, cobalt pentachlorothiophenol, pentafluorothiophenol, zinc pentafluorothiophenol, and blends thereof. Preferred candidates are pentachlorothiophenol (available from Strucktol Company of Stow, Ohio), zinc pentachlorothiophenol (available from eChinachem of San Francisco, Calif.), and blends thereof. Additional examples are described in commonly-owned copending U.S. patent application Ser. No. 10/882,130, which is incorporated herein by reference in its entirety.

The organosulfur cis-to-trans catalyst, when present, is preferably present in an amount sufficient to produce the reaction product so as to contain at least about 12 percent trans-polybutadiene isomer, but typically is greater than about 32 percent trans-polybutadiene isomer based on the total resilient polymer component. In another embodiment, metal-containing organosulfur components can be used according to the invention. Suitable metal-containing organosulfur components include, but are not limited to, cadmium, copper, lead, and tellurium analogs of diethyldithiocarbamate, diamyldithiocarbamate, and dimethyldithiocarbamate, or mixtures thereof. Additional suitable examples of can be found in commonly owned and co-pending U.S. patent application Ser. No. 10/402,592.

Suitable substituted or unsubstituted aromatic organic components that do not include sulfur or a metal include, but are not limited to, 4,4'-diphenyl acetylene, azobenzene, or a mixture thereof. The aromatic organic group preferably ranges in size from C₆ to C₂₀, and more preferably from C₆ to C₁₀. Suitable inorganic sulfide components include, but are not limited to titanium sulfide, manganese sulfide, and sulfide analogs of iron, calcium, cobalt, molybdenum, tungsten, copper, selenium, yttrium, zinc, tin, and bismuth.

The cis-to-trans catalyst can also include a Group VIA component. Elemental sulfur and polymeric sulfur are commercially available from, e.g., Elastochem, Inc. of Chardon, Ohio. Exemplary sulfur catalyst compounds include PB(RM-S)-80 elemental sulfur and PB(CRST)-65 polymeric sulfur, each of which is available from Elastochem, Inc. An exemplary tellurium catalyst under the trade name TELLOY and an exemplary selenium catalyst under the tradename VANDEX are each commercially available from RT Vanderbilt.

A free-radical source, often alternatively referred to as a free-radical initiator, is required in the composition and method. The free-radical source is typically a peroxide, and preferably an organic peroxide. Suitable free-radical sources

include di-t-amyl peroxide, di(2-t-butyl-peroxyisopropyl) benzene peroxide, 3,3,5-trimethyl cyclohexane, a-a bis(t-butylperoxy) diisopropylbenzene, 1,1-bis(t-butylperoxy)-3,3,5-trimethylcyclohexane, dicumyl peroxide, di-t-butyl peroxide, 2,5-di-(t-butylperoxy)-2,5-dimethyl hexane, n-butyl-4,4-bis(t-butylperoxy)valerate, lauryl peroxide, benzoyl peroxide, t-butyl hydroperoxide, and the like, and any mixture thereof.

A crosslinking agent is included to increase the hardness of the reaction product. Suitable crosslinking agents include one or more metallic salts of unsaturated fatty acids or monocarboxylic acids, such as zinc, aluminum, sodium, lithium, nickel, calcium, or magnesium acrylate salts, and the like, and mixtures thereof. Preferred acrylates include zinc acrylate, zinc diacrylate (ZDA), zinc methacrylate, and zinc dimethacrylate (ZDMA), and mixtures thereof. The crosslinking agent must be present in an amount sufficient to crosslink a portion of the chains of polymers in the resilient polymer component. For example, the desired compression may be obtained by adjusting the amount of crosslinking. This may be achieved, for example, by altering the type and amount of crosslinking agent, a method well-known to those of ordinary skill in the art.

The compositions of the present invention may also include fillers, added to the polybutadiene material to adjust the density and/or specific gravity of the core or to the cover. Fillers are typically polymeric or mineral particles. Exemplary fillers include precipitated hydrated silica, clay, talc, asbestos, glass fibers, aramid fibers, mica, calcium metasilicate, barium sulfate, zinc sulfide, lithopone, silicates, silicon carbide, diatomaceous earth, polyvinyl chloride, carbonates such as calcium carbonate and magnesium carbonate, metals such as titanium, tungsten, aluminum, bismuth, nickel, molybdenum, iron, lead, copper, boron, cobalt, beryllium, zinc, and tin, metal alloys such as steel, brass, bronze, boron carbide whiskers, and tungsten carbide whiskers, metal oxides such as zinc oxide, iron oxide, aluminum oxide, titanium oxide, magnesium oxide, and zirconium oxide, particulate carbonaceous materials such as graphite, carbon black, cotton flock, natural bitumen, cellulose flock, and leather fiber, micro balloons such as glass and ceramic, fly ash, and combinations thereof.

Antioxidants may also optionally be included in the polybutadiene material in the centers produced according to the present invention. Antioxidants are compounds that can inhibit or prevent the oxidative degradation of the polybutadiene. Antioxidants useful in the present invention include, but are not limited to, dihydroquinoline antioxidants, amine type antioxidants, and phenolic type antioxidants.

Other optional ingredients, such as accelerators, e.g., tetramethylthiuram, peptizers, processing aids, processing oils, plasticizers, dyes and pigments, as well as other additives well known to those of ordinary skill in the art may also be used in the present invention in amounts sufficient to achieve the purpose for which they are typically used.

The PGA compression of the center or of the core, of golf balls prepared according to the invention is typically from about 160 or less as measured on a sphere, preferably about 10 to about 150, more preferably about 15 to about 140 and most preferably about 20 to about 120. Various equivalent methods of measuring compression exist. For example, a 70 Atti compression (also previously referred to as the "PGA Compression") is equivalent to a center hardness of 3.2 mm deflection under a 100 kg load and a "spring constant" of 36 Kgf/mm. In one embodiment, the golf ball center has a deflection of about 3.3 mm to 7 mm under a 130 kg-10 kg test. The various

methods for measuring compression are discussed in the J. Dalton paper, discussed above.

Any of the suitable center materials discussed above can be used in any other layers on the ball.

The intermediate layers may comprise materials such as thermosetting polybutadiene or other diene rubber based formulations, thermoplastic or thermosetting polyurethanes, polyureas, partially or fully neutralized HNP, polyolefins including metallocene or other single site catalyzed polymers, polymers comprising silicone, polyamides, polyesters, polyether amides, and polyester amides. Suitable thicknesses of the intermediate layers are discussed above.

The outer cover may also comprise a polybutadiene, a cross-linking agent, a free radical source, and high specific gravity fillers. An example of such polybutadiene-based material is as follows:

100 parts polybutadiene polymer,
5-10 parts metal acrylate or methacrylate cross-linking agent,
5 parts zinc oxide as the density modifying material,
2 parts dicumyl peroxide as the free radical source, and
X part(s) metal powder filler, such as tungsten or other heavy metals, wherein

cially available from DuPont as HPF 1000 or 2000 and as neat spheres have COR of 0.800 to 0.853, and Shore D hardness of 48 to 51.

The multi-layer golf ball in this invention is different from previous golf balls which tend to have a relatively fast center and either (a) a faster inner cover layer and a slower outer cover such as those exemplified by the Titleist golf balls, or (b) a slower inner cover and a faster outer cover layer such as those exemplified by the Titleist golf balls and Newing balls, etc. There are other dual core golf balls that have a mixed velocity gradient, but there is no progressively decreasing COR values from the center to the cover layer. In this invention, the use of a fast center allows for less resilient materials in each successive core-intermediate layer, thus allowing the use of more rubbery materials as intermediate layers rather than the use of hard intermediate layers in existing golf balls. Therefore, the invention relates to the construction of new and improved golf balls having novel playability benefits and having COR values that are more beneficial to specific swing speeds than existing golf balls.

Data illustrating the novel construction of the present invention compared to existing golf balls is shown below.

TABLE V

COMPARATIVE FOUR-LAYER SAMPLES AND INVENTIVE SAMPLE								
Ball Name	Sizes (in)	CoR(C)	CoR(C) - CoR(C1)	CoR(C1) - CoR(C2)	CoR(C2) - CoR(C3)	$\frac{[CoR(C) - CoR(C1)]}{T(C1)} \times 10^{-3}$	$\frac{[CoR(C1) - CoR(C2)]}{T(C2)} \times 10^{-3}$	$\frac{[CoR(C2) - CoR(C3)]}{T(C3)} \times 10^{-3}$
Nike One	1.395/1.487/ 1.590/1.682	0.824	0.007	0.002	0.007	0.152	0.039	0.152
Titleist 4 Piece	1.000/1.549/ 1.619/1.681	0.765	-0.040	-0.009	0.006	-0.145	-0.250	0.194
Inventive	1.450/1.550/ 1.620/1.681	0.835	0.015	0.007	0.008	0.300	0.200	0.258

COMPARATIVE 3-LAYER SAMPLES							
Ball Name	Sizes (in) Center/Inter./Cover	CoR(C)	CoR(C) - CoR(C1)	CoR(C1) - CoR(C2)	$\frac{[CoR(C) - CoR(C1)]}{[T(C) - T(C1)]} \times 10^{-3}$	$\frac{[CoR(C1) - CoR(C2)]}{[T(C1) - T(C2)]} \times 10^{-3}$	
Newing EZ Drive	1.390/1.522/1.683	0.756	-0.007	-0.042	-0.106	-0.519	
Hibrid Everio	1.448/1.558/1.683	0.754	-0.010	-0.031	-0.182	-0.492	
TaylorMade Inergel Pro Distance	1.487/1.582/1.684	0.771	-0.002	-0.017	-0.042	-0.340	
Tour Special Metal Mix	1.389/1.539/1.681	0.766	-0.019	-0.013	-0.253	-0.183	
Strata Professional Control	1.481/1.572/1.681	0.770	-0.006	-0.010	-0.130	-0.182	
Super Newing	1.437/1.568/1.681	0.780	-0.011	-0.013	-0.167	-0.228	
Maxfli EXT	1.479/1.580/1.684	0.799	-0.008	-0.009	-0.157	-0.180	
Titleist 3 Piece	1.549/1.620/1.681	0.803	-0.012	0.007	-0.333	0.222	

Where C = subassembly containing the center;

C1 = subassembly containing the center and intermediate layer;

C2 = subassembly containing the center and two intermediate layers or three-layer ball; and

C3 = ball with all four layers.

X depends on the desired specific gravity of the batch and wherein X is a number, integers and real numbers,

In a preferred embodiment, the outer cover layer comprises an HNP that is a fully neutralized polymer with ions such as Mg, Na, Zn, Li, K, Ca or mixtures thereof, and one or more of a fatty acid including oleic acid, stearic acid or behenic acid, or the magnesium salt thereof. These materials are commer-

Unless otherwise expressly specified, all of the numerical ranges, amounts, values and percentages such as those for amounts of materials, and others in the specification may be read as if prefaced by the word "about" even though the term "about" may not expressly appear with the value, amount or range. Accordingly, unless indicated to the contrary, the numerical parameters set forth in the specification and

attached claims are approximations that may vary depending upon the desired properties sought to be obtained by the present invention. At the very least, and not as an attempt to limit the application of the doctrine of equivalents to the scope of the claims, each numerical parameter should at least be construed in light of the number of reported significant digits and by applying ordinary rounding techniques.

Notwithstanding that the numerical ranges and parameters setting forth the broad scope of the invention are approximations, the numerical values set forth in the specific examples are reported as precisely as possible. Any numerical value, however, inherently contain certain errors necessarily resulting from the standard deviation found in their respective testing measurements. Furthermore, when numerical ranges of varying scope are set forth herein, it is contemplated that any combination of these values inclusive of the recited values may be used.

While it is apparent that the illustrative embodiments of the invention disclosed herein fulfill the preferred embodiments of the present invention, it is appreciated that numerous modifications and other embodiments may be devised by those skilled in the art. Examples of such modifications include slight variations of the numerical values discussed above. Hence, the numerical values stated above and claimed below specifically include those values and the values that are approximately or nearly close to the stated and claimed values. Therefore, it will be understood that the appended claims are intended to cover all such modifications and embodiments, which would come within the spirit and scope of the present invention.

What is claimed is:

1. A multi-layer golf ball comprising a center, a cover layer, and at least two intermediate layers between the center and the cover layer,

wherein each subassembly of the golf ball has a combined coefficient of restitution value of COR_C for the center, COR_{C1} for a first subassembly with a first intermediate layer adjacent to the center, COR_{C2} for a second subassembly with a second intermediate layer adjacent to the first intermediate layer and COR_{C3} for the ball including the cover layer, and

$COR_C \cong COR_{C1} + 0.004$; $COR_{C1} \cong COR_{C2} + 0.004$;

$COR_{C2} \cong COR_{C3} + 0.004$, and

wherein COR_C is at least 0.815.

2. The multi-layer golf ball of claim 1, wherein COR_C is at least 0.825.

3. The multi-layer golf ball of claim 1, wherein COR_C is at least 0.830.

4. The multi-layer golf ball of claim 1, wherein COR_{C1} is at least 0.810.

5. The multi-layer golf ball of claim 1, wherein COR_{C1} is at least 0.820.

6. The multi-layer golf ball of claim 1, wherein COR_{C2} is at least 0.800.

7. The multi-layer golf ball of claim 1, wherein COR_{C2} is at least 0.810.

8. A multi-layer golf ball comprising a center, a cover layer, and at least two intermediate layers between the center and the cover layer,

wherein each subassembly of the golf ball has a combined coefficient of restitution value of COR_C for the center, COR_{C1} for a first subassembly with a first intermediate layer adjacent to the center, COR_{C2} for a second subassembly with a second intermediate layer adjacent to the first intermediate layer and COR_{C3} for the ball including the cover layer, and

$COR_C \cong COR_{C1} + 0.004$; $COR_{C1} \cong COR_{C2} + 0.004$; $COR_{C2} \cong COR_{C3} + 0.004$, and

wherein COR_C is at least 0.815, and

wherein the change in coefficient of restitution from one subassembly to the next larger assembly per the thickness of the next larger subassembly is at least 0.00015 per thousandth of an inch.

9. The multi-layer golf ball of claim 8, wherein said change in coefficient of restitution is at least about 0.00025 per thousandth of an inch.

10. The multi-layer golf ball of claim 8, wherein the center comprises a highly neutralized polymer formed from a reaction between acid groups on a polymer, a suitable source of cation, an organic acid or the corresponding salt, and

the amount of the suitable source of cation is sufficient to neutralize the acid groups by at least about 80%.

11. The multi-layer golf ball of claim 10, wherein the amount of the suitable source of cation is sufficient to neutralize the acid groups by about 90%.

* * * * *