



US007510550B2

(12) **United States Patent**
Deniega et al.

(10) **Patent No.:** **US 7,510,550 B2**
(45) **Date of Patent:** **Mar. 31, 2009**

(54) **CATHETER FOR UNIFORM DELIVERY OF MEDICATION**

(75) Inventors: **Jose Castillo Deniega**, Lake Forest, CA (US); **Roger Massengale**, Mission Viejo, CA (US); **Kenneth W. Rake**, Laguna Niguel, CA (US)

(73) Assignee: **I-Flow Corporation**, Lake Forest, CA (US)

(*) Notice: Subject to any disclaimer, the term of this patent is extended or adjusted under 35 U.S.C. 154(b) by 0 days.

(21) Appl. No.: **10/435,946**

(22) Filed: **May 12, 2003**

(65) **Prior Publication Data**
US 2004/0054351 A1 Mar. 18, 2004

Related U.S. Application Data
(63) Continuation-in-part of application No. 10/031,913, filed as application No. PCT/US00/19746 on Jul. 19, 2000, which is a continuation-in-part of application No. 09/363,228, filed on Jul. 19, 1999, now Pat. No. 6,350,253.

(51) **Int. Cl.**
A61M 25/00 (2006.01)
(52) **U.S. Cl.** **604/523**
(58) **Field of Classification Search** 604/19, 604/22, 93.01, 131, 164.01, 164.13, 171, 604/264, 523, 284, 532, 535, 537, 104-106
See application file for complete search history.

(56) **References Cited**
U.S. PATENT DOCUMENTS
3,595,241 A 7/1971 Sheridan
3,821,956 A 7/1974 Gordhamer
4,954,388 A * 9/1990 Mallouk et al. 428/198
5,032,113 A 7/1991 Burns

5,066,278 A 11/1991 Hirschberg et al.
5,184,627 A 2/1993 de Toledo
5,201,723 A 4/1993 Quinn
5,213,576 A * 5/1993 Abiuso et al. 604/103.01

(Continued)

FOREIGN PATENT DOCUMENTS

DE 3400874 C1 1/1984

(Continued)

OTHER PUBLICATIONS

Office Action in U.S. Appl. No. 10/031,913, mailed Nov. 16, 2005 in 6 pages, Inventor: Jose Castillo Deniega.

Primary Examiner—Kevin C Sirmons
Assistant Examiner—Elizabeth R MacNeil
(74) *Attorney, Agent, or Firm*—Knobbe, Martens, Olson & Bear, LLP

(57) **ABSTRACT**

A catheter is provided for uniform distribution of fluid medication within an anatomical region. One embodiment of the catheter is comprised of an elongate tubular catheter body defining a lumen. A distal end of the lumen is closed and a portion of the catheter body includes a plurality of openings thereby defining an infusion section of the catheter. A tubular sheath is constructed from a porous material and is positioned over the infusion section. The tubular sheath extends at least a length of the infusion section. The tubular sheath and the catheter body are configured such that fluid within the lumen must pass through the tubular sheath to exit the catheter. In at least one embodiment, a pore size of the porous material is less than about 0.5 microns.

22 Claims, 7 Drawing Sheets

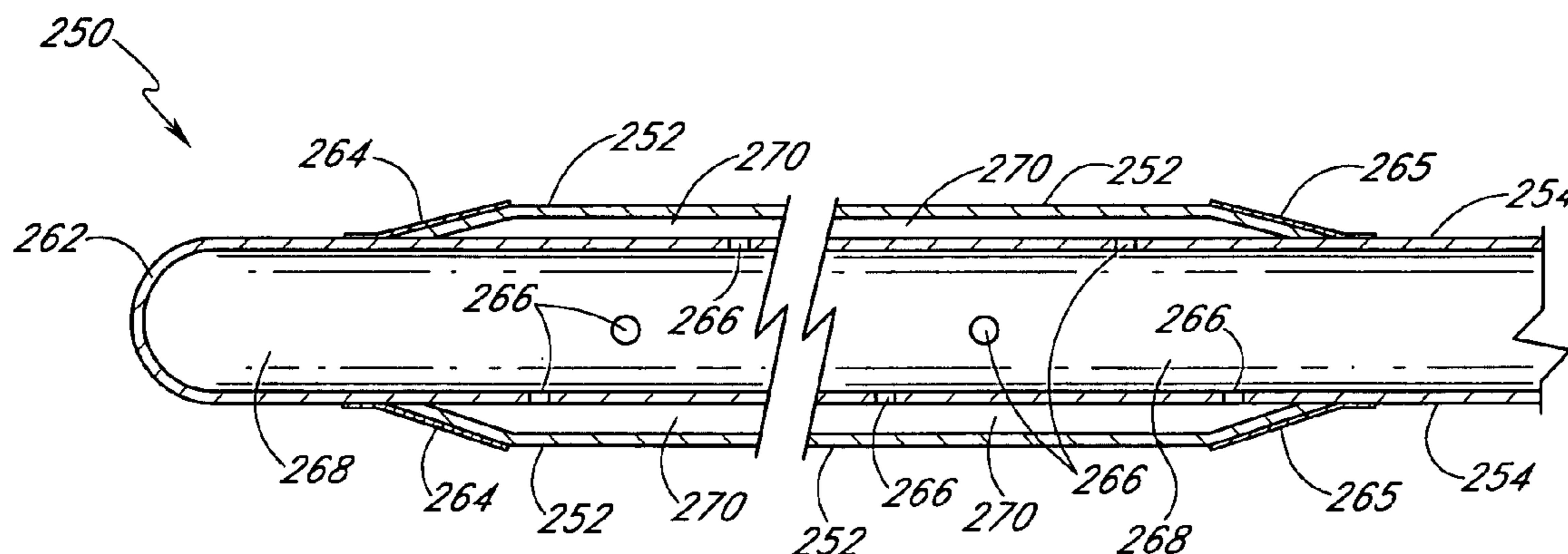

US 7,510,550 B2

Page 2

U.S. PATENT DOCUMENTS

5,267,979 A 12/1993 Appling et al.
5,269,755 A * 12/1993 Bodicky 604/523
5,279,565 A * 1/1994 Klein et al. 604/105
5,356,388 A 10/1994 Sepetka et al.
5,370,610 A 12/1994 Reynolds
5,376,083 A 12/1994 Mische
5,425,723 A * 6/1995 Wang 604/523
5,533,516 A * 7/1996 Sahatjian 600/562
5,643,228 A 7/1997 Schucart et al.
5,702,372 A 12/1997 Nelson
5,709,874 A * 1/1998 Hanson et al. 604/264
5,776,111 A 7/1998 Tesio
5,800,407 A 9/1998 Eldor
5,833,652 A 11/1998 Preissman et al.
5,846,216 A 12/1998 Gonzales et al.
5,957,899 A 9/1999 Spears et al.
6,093,180 A * 7/2000 Elsberry 604/506
6,102,903 A * 8/2000 Tremulis 604/529

6,350,253 B1 2/2002 Deniega et al.
6,537,194 B1 3/2003 Winkler
6,537,241 B1 3/2003 Odland
6,955,661 B1 * 10/2005 Herweck et al. 604/264
2003/0036728 A1 2/2003 Samson et al.

FOREIGN PATENT DOCUMENTS

EP 0 804 936 A2 11/1997
FR 2 539 298 1/1983
FR 2 622 805 11/1987
GB 2 277 035 10/1994
JP 4-327857 11/1992
WO WO 92/00113 1/1992
WO WO 92/11895 7/1992
WO WO 96/33761 10/1996
WO WO 97/49447 12/1997
WO WO 01/05210 1/2001

* cited by examiner

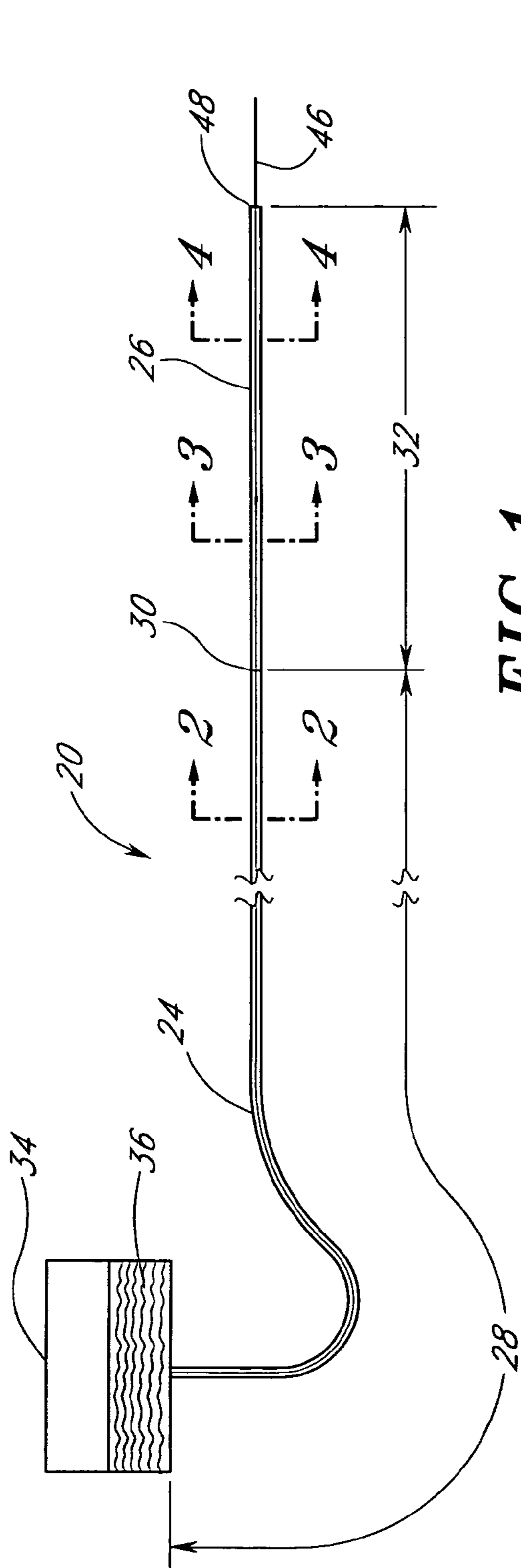

FIG. 1

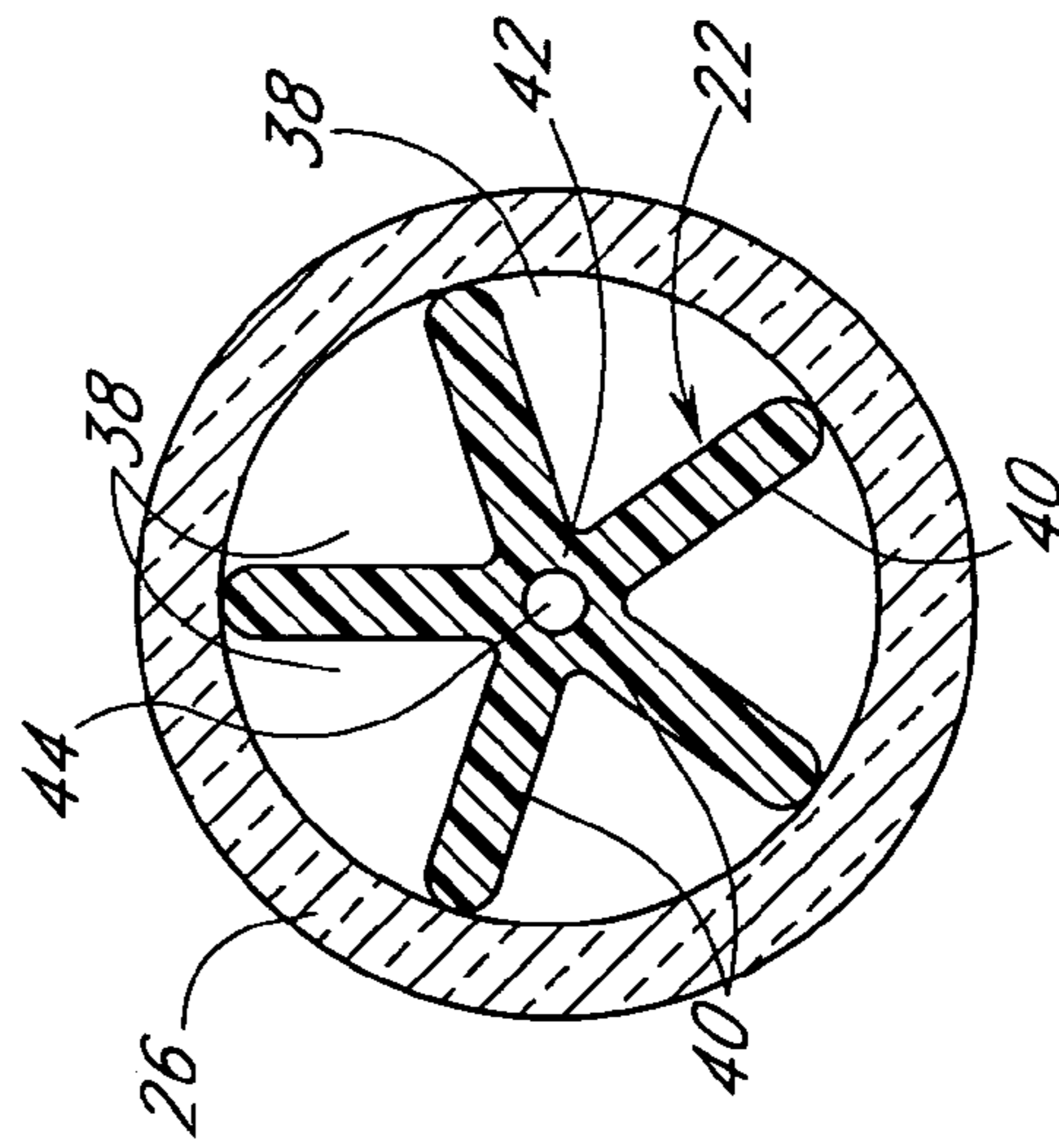

FIG. 2

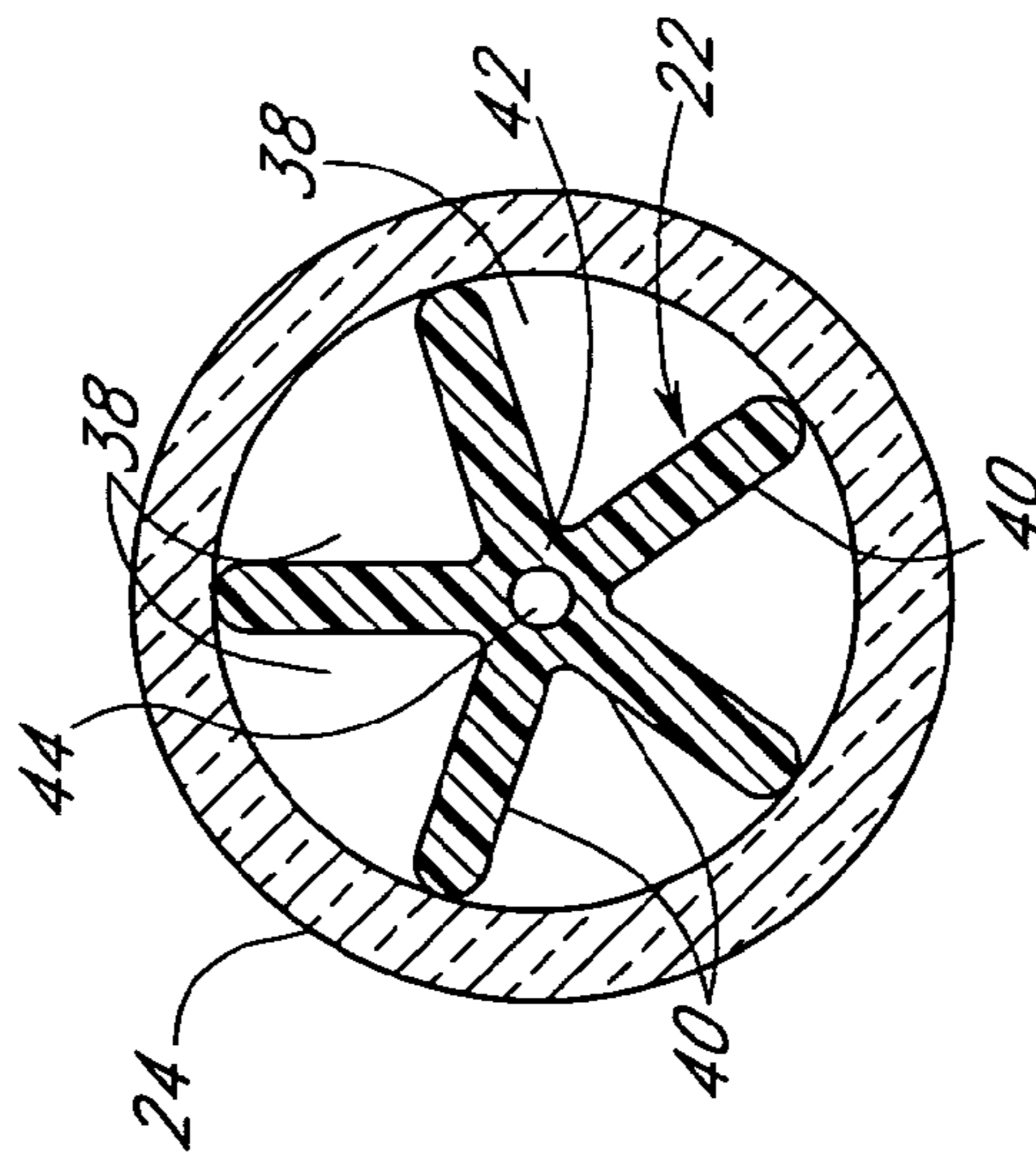

FIG. 3

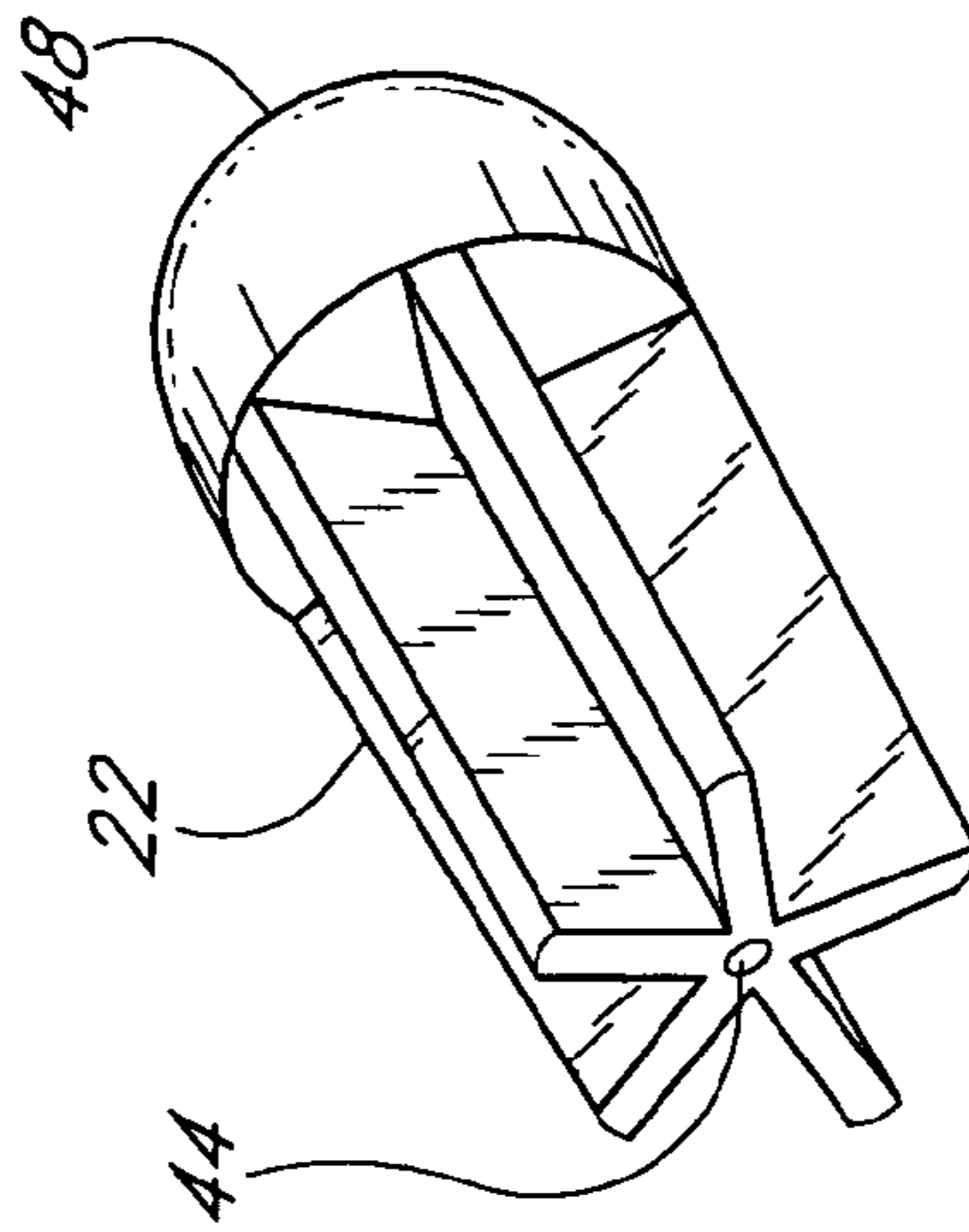

FIG. 4

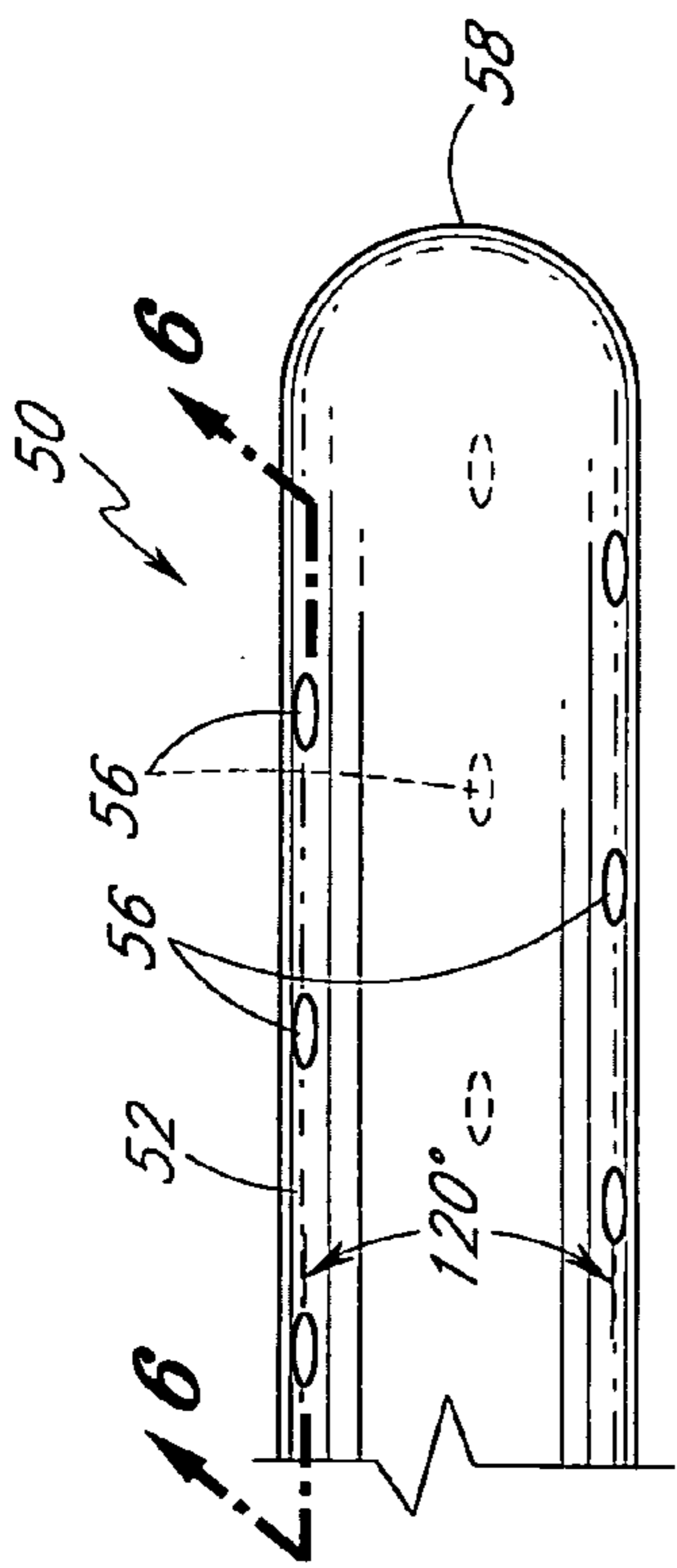

FIG. 5

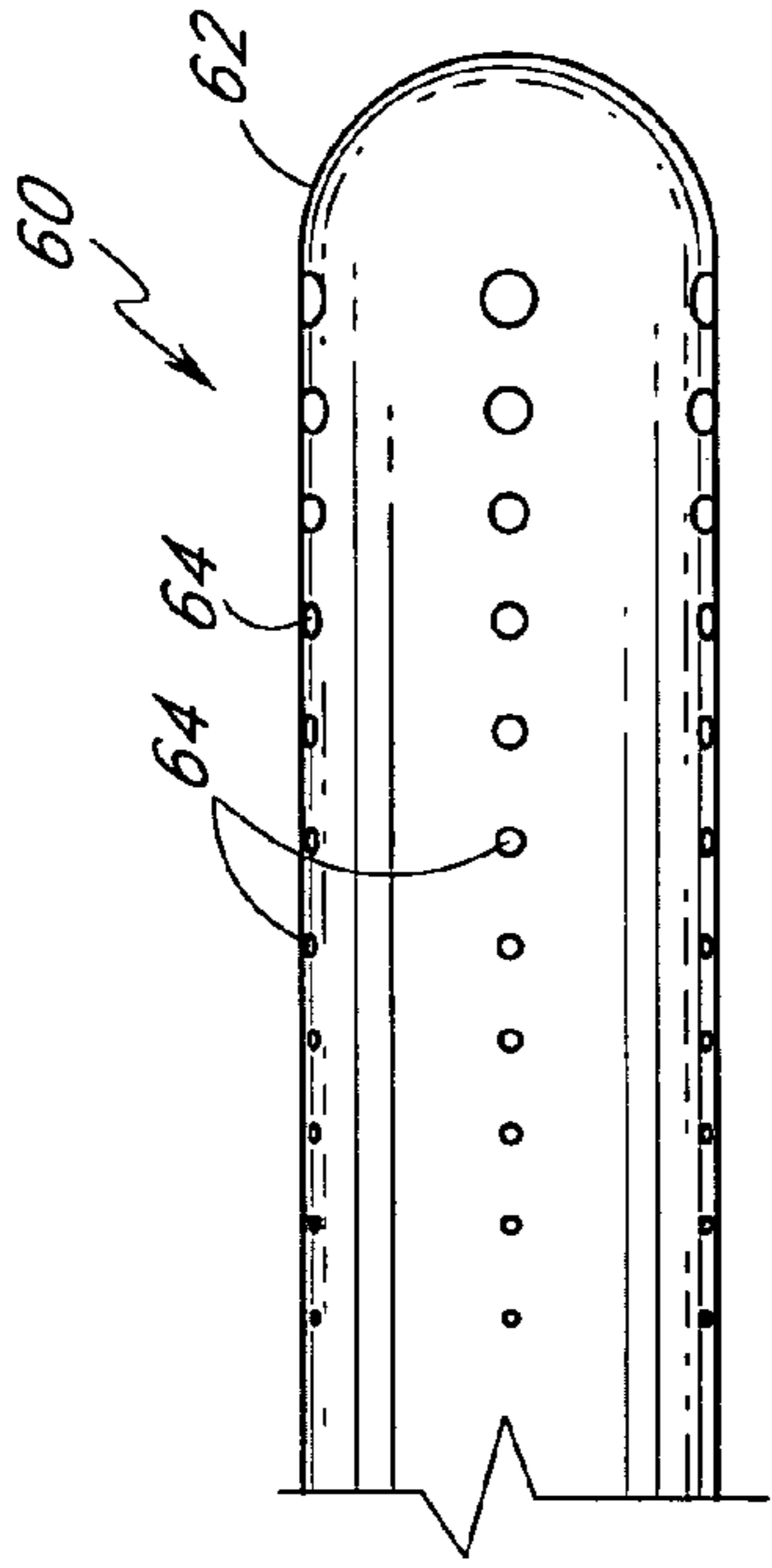

FIG. 8

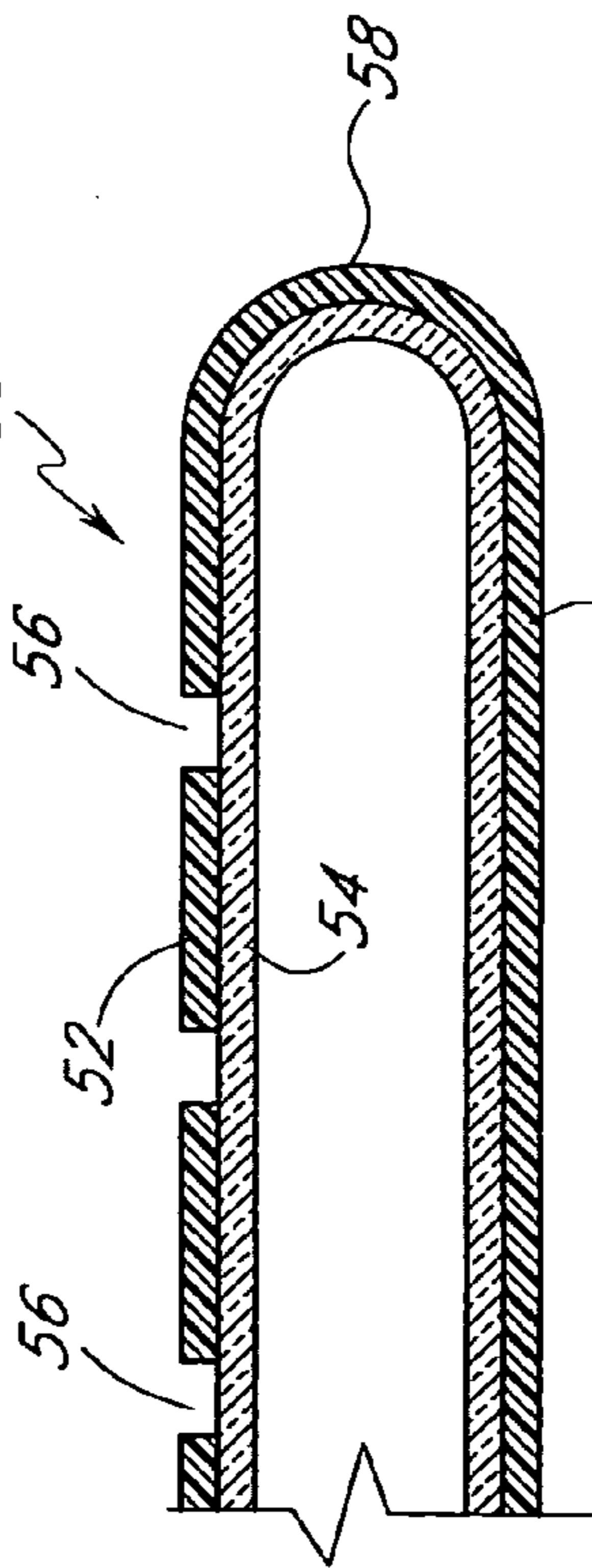

FIG. 6

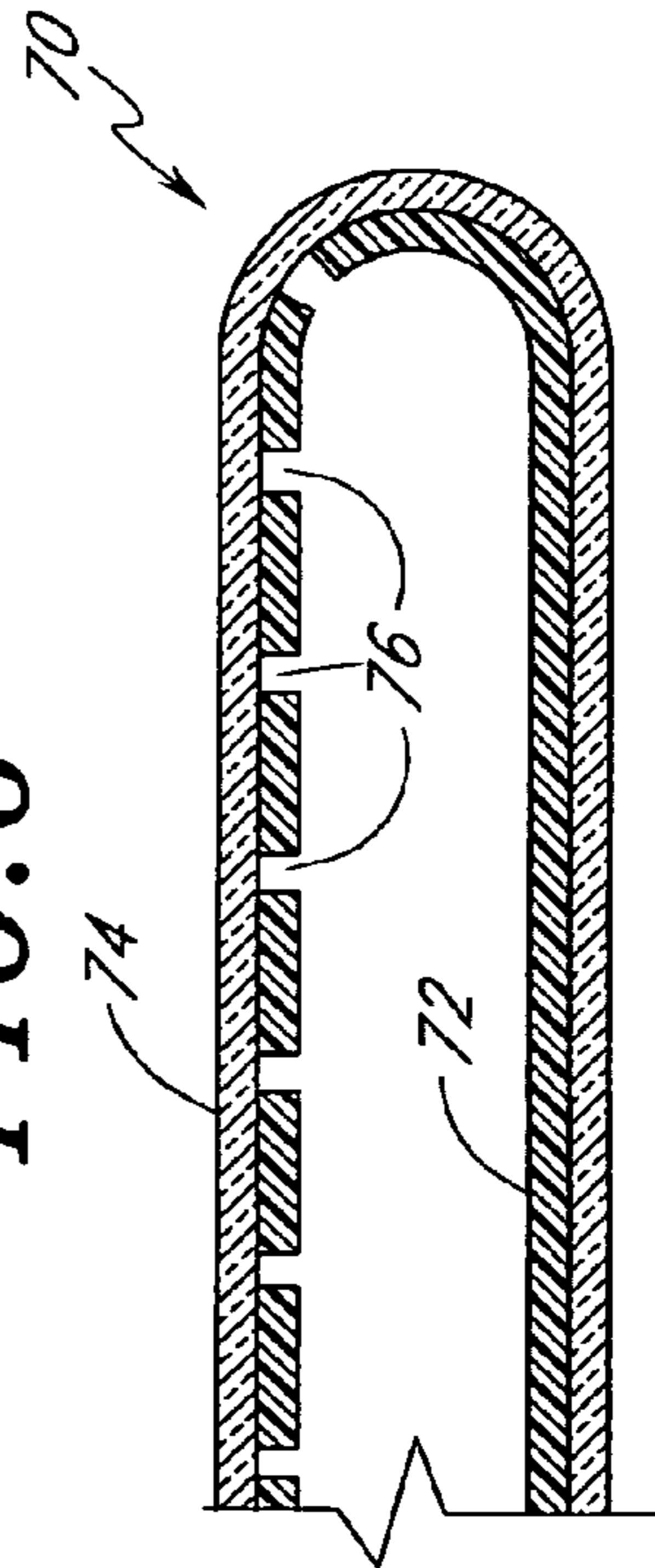

FIG. 7

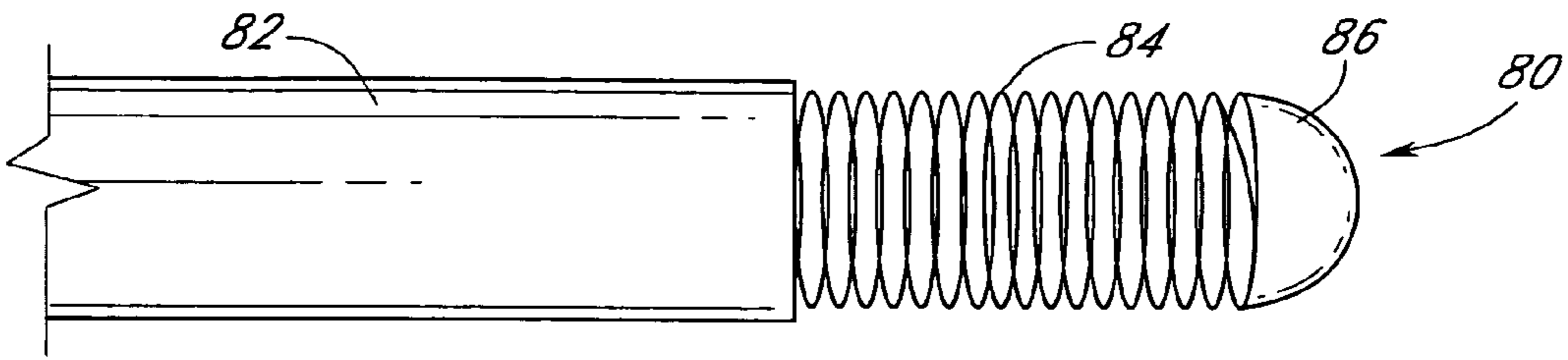

FIG. 9

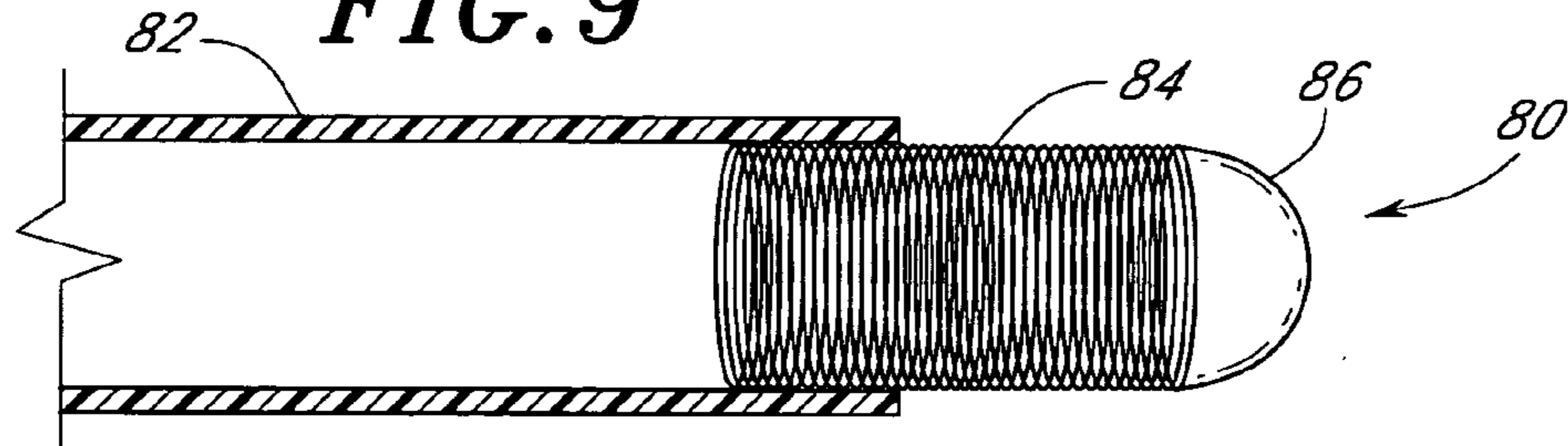

FIG. 10A

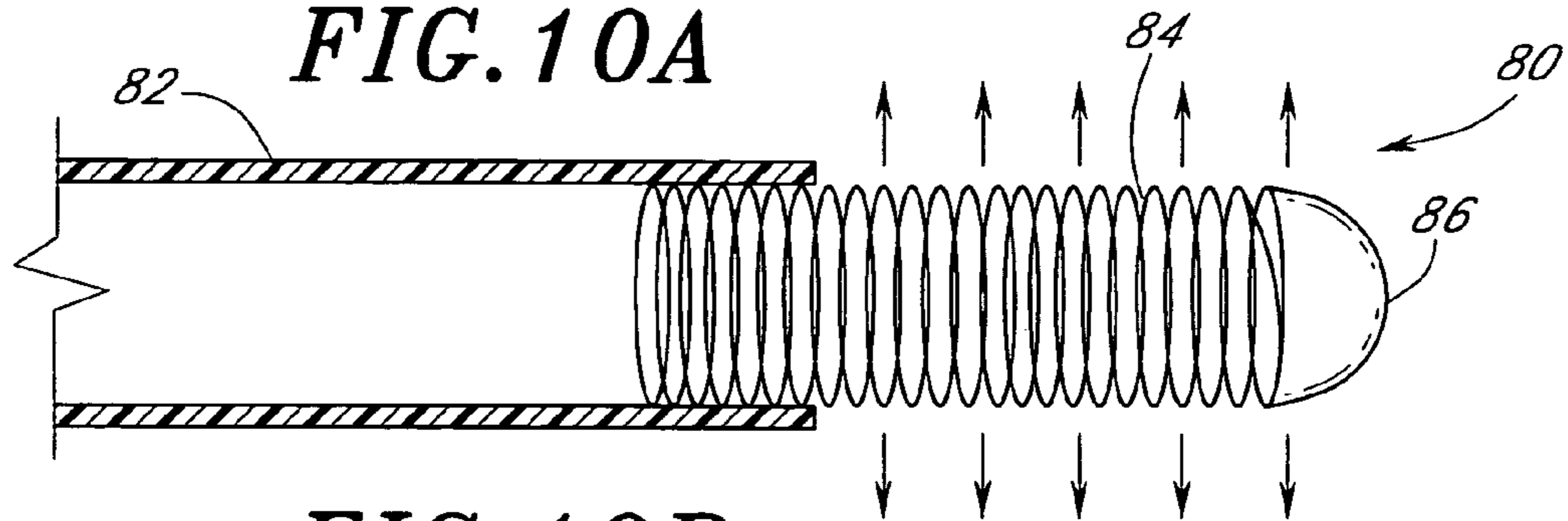

FIG. 10B

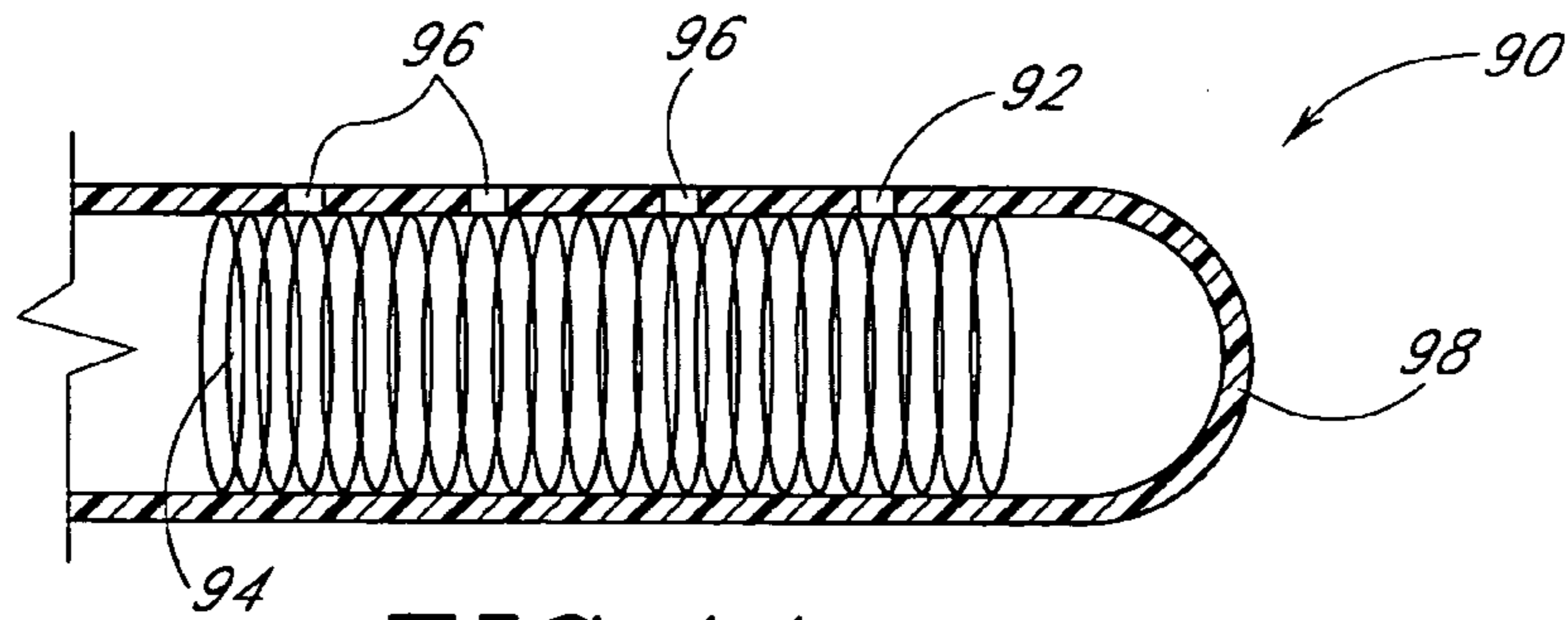

FIG. 11

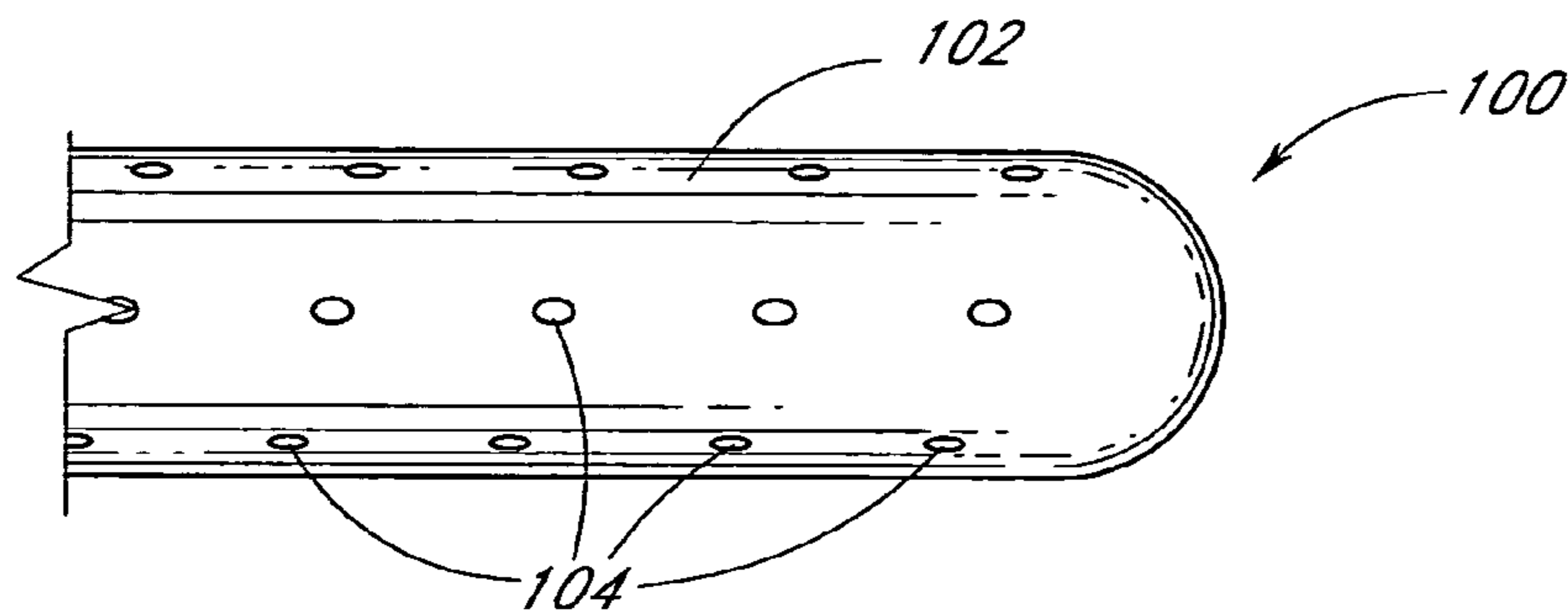

FIG. 12

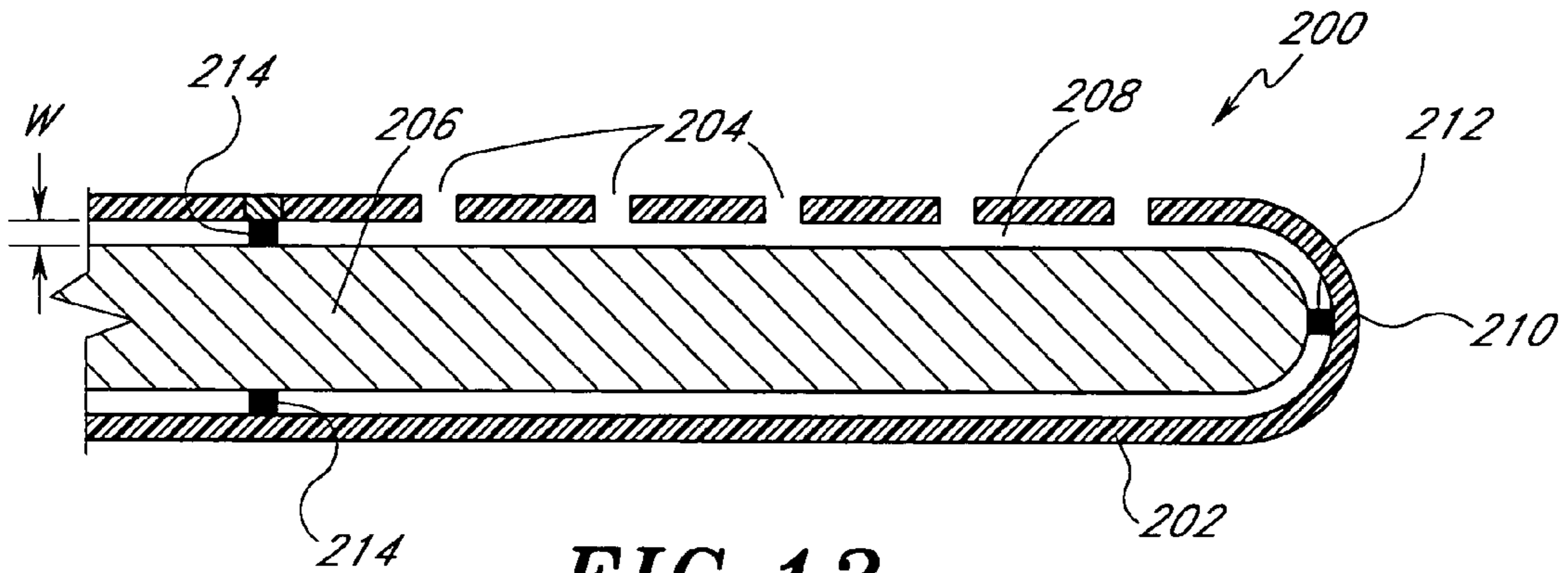

FIG. 13

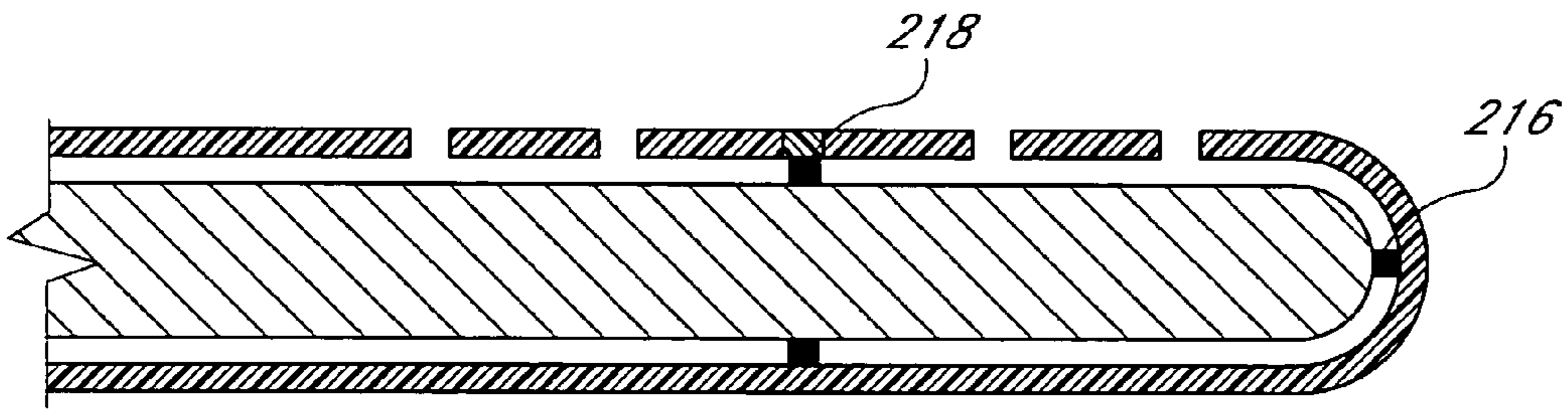

FIG. 14

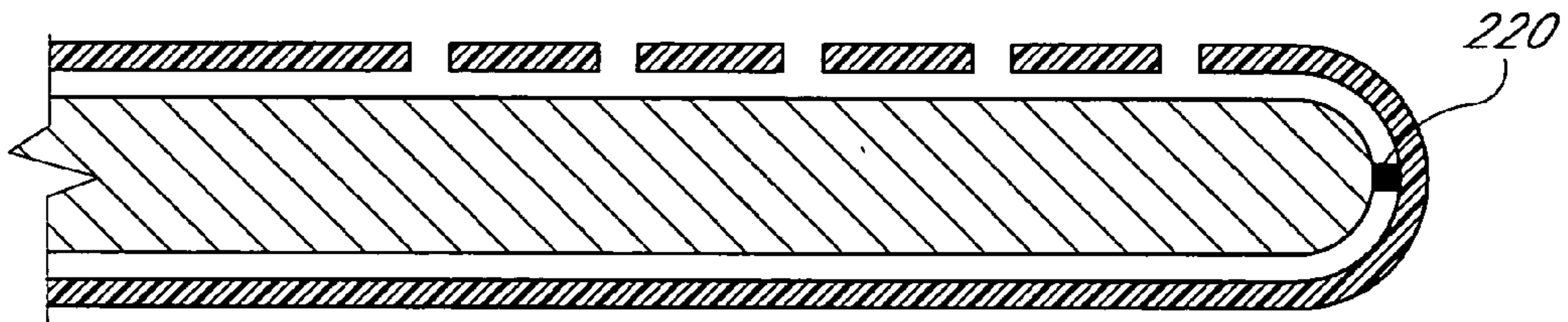

FIG. 15

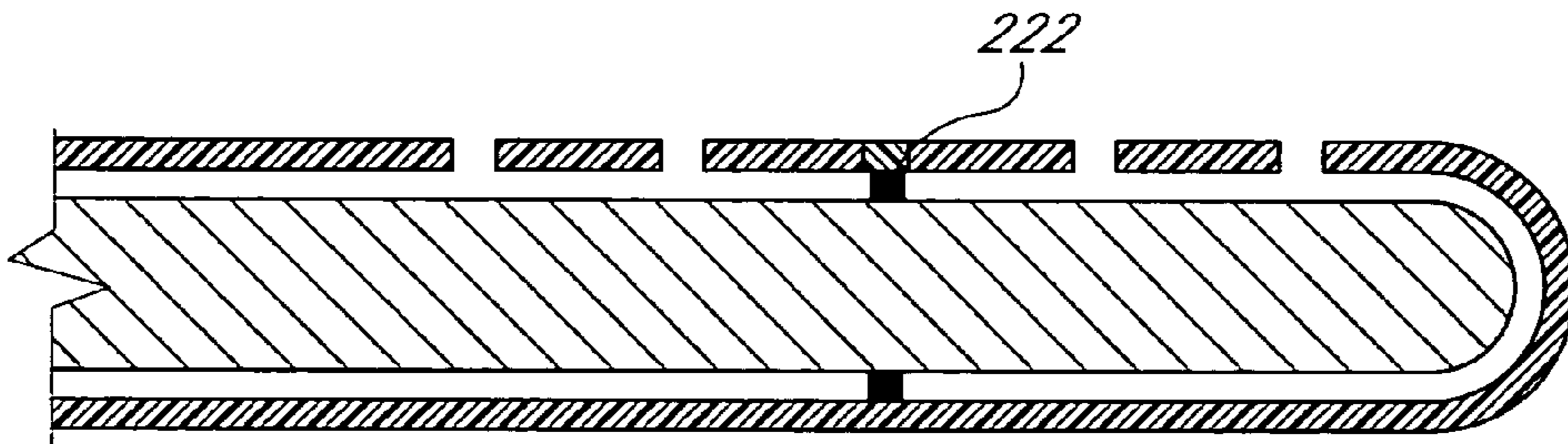

FIG. 16

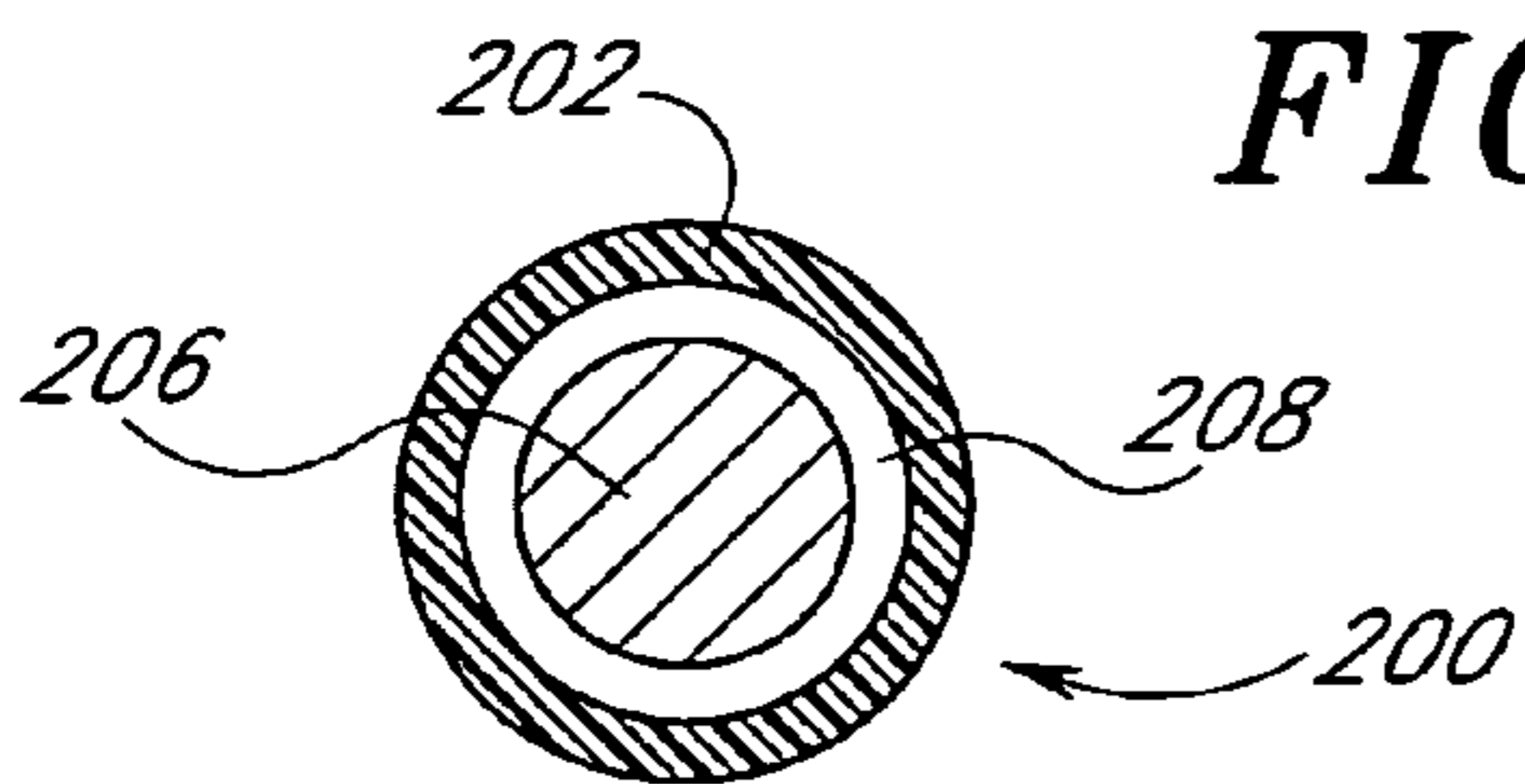

FIG. 17

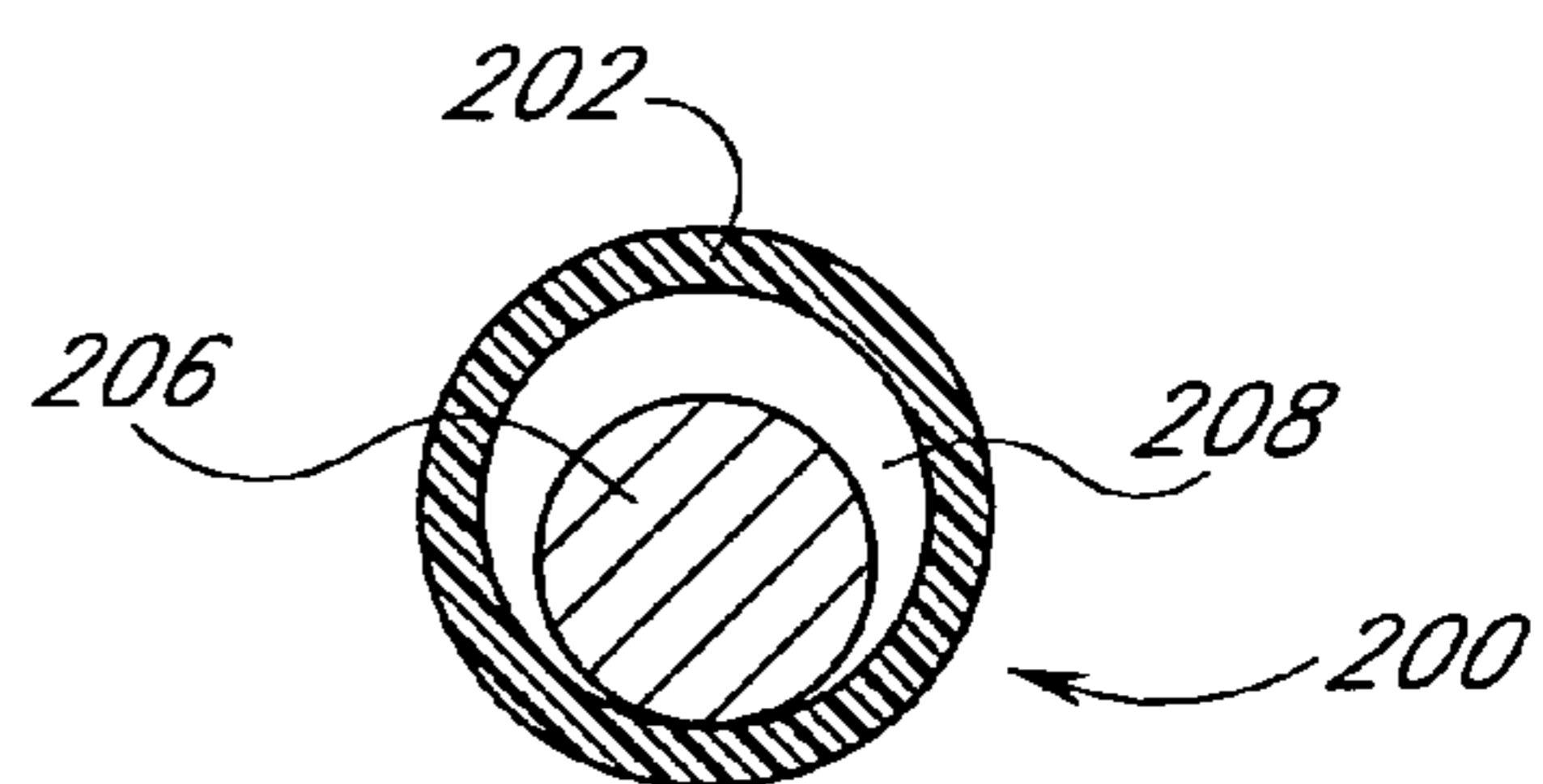

FIG. 18

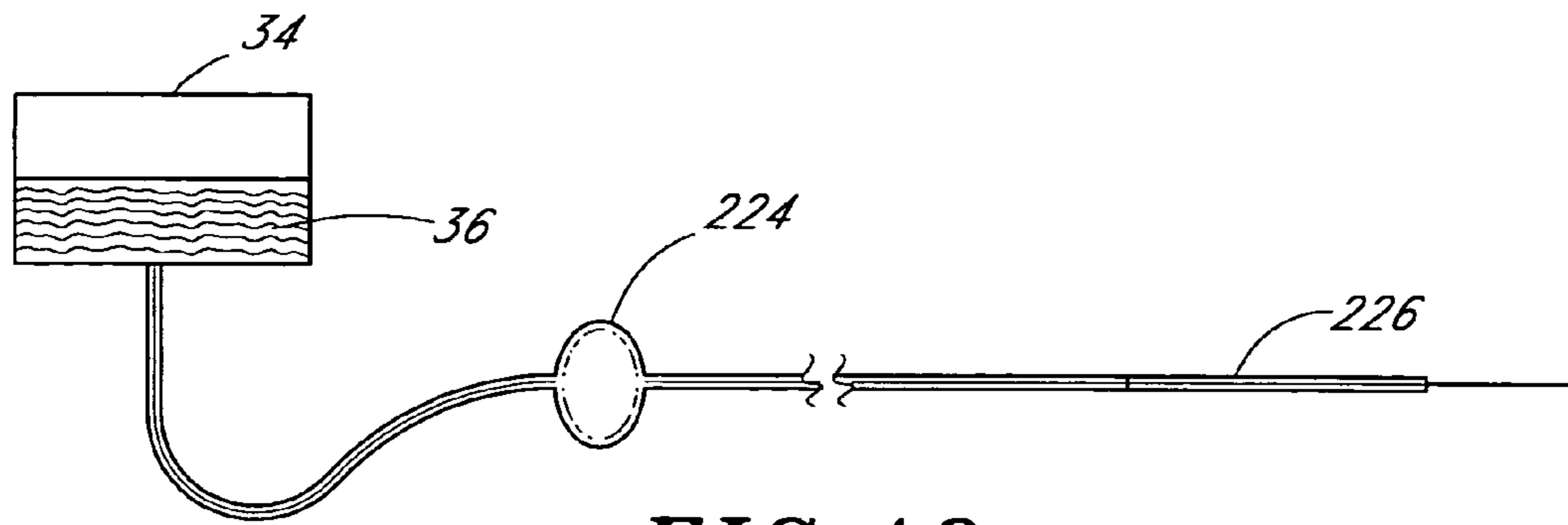

FIG. 19

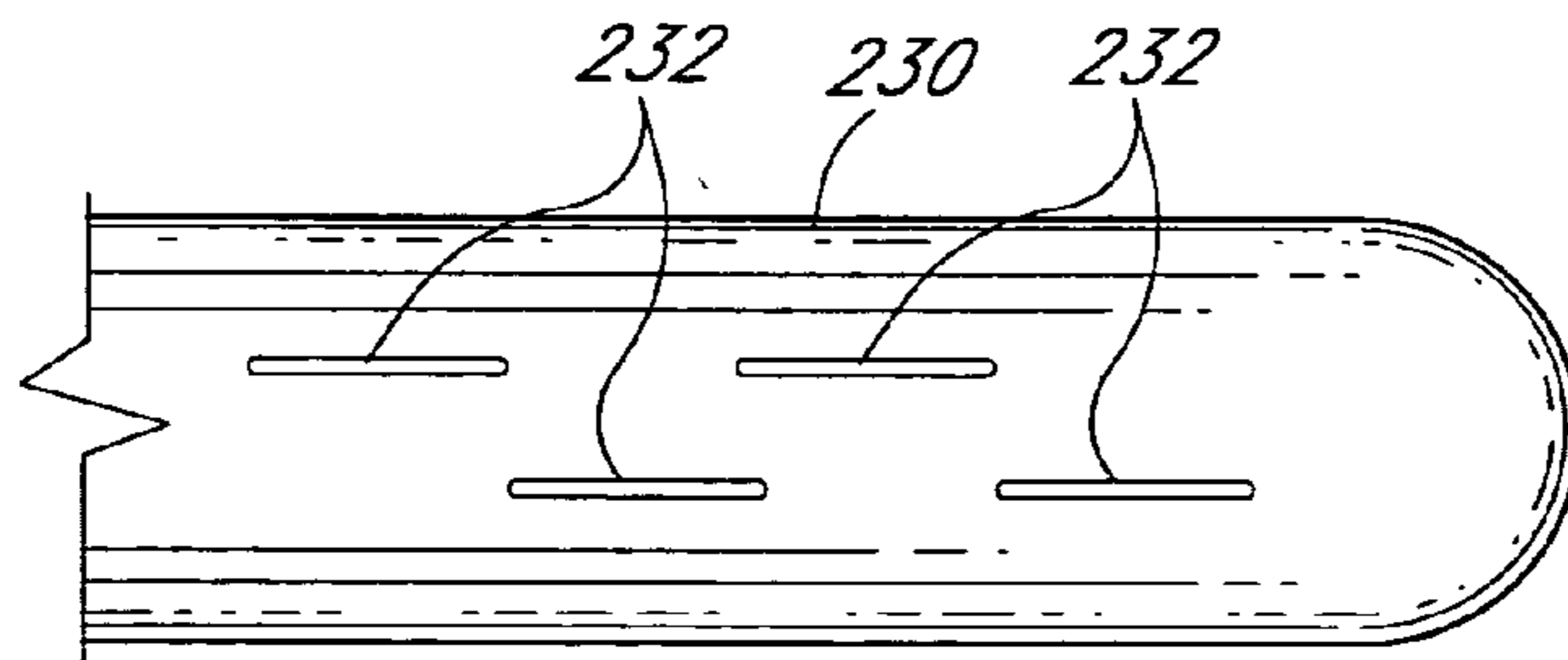

FIG. 20

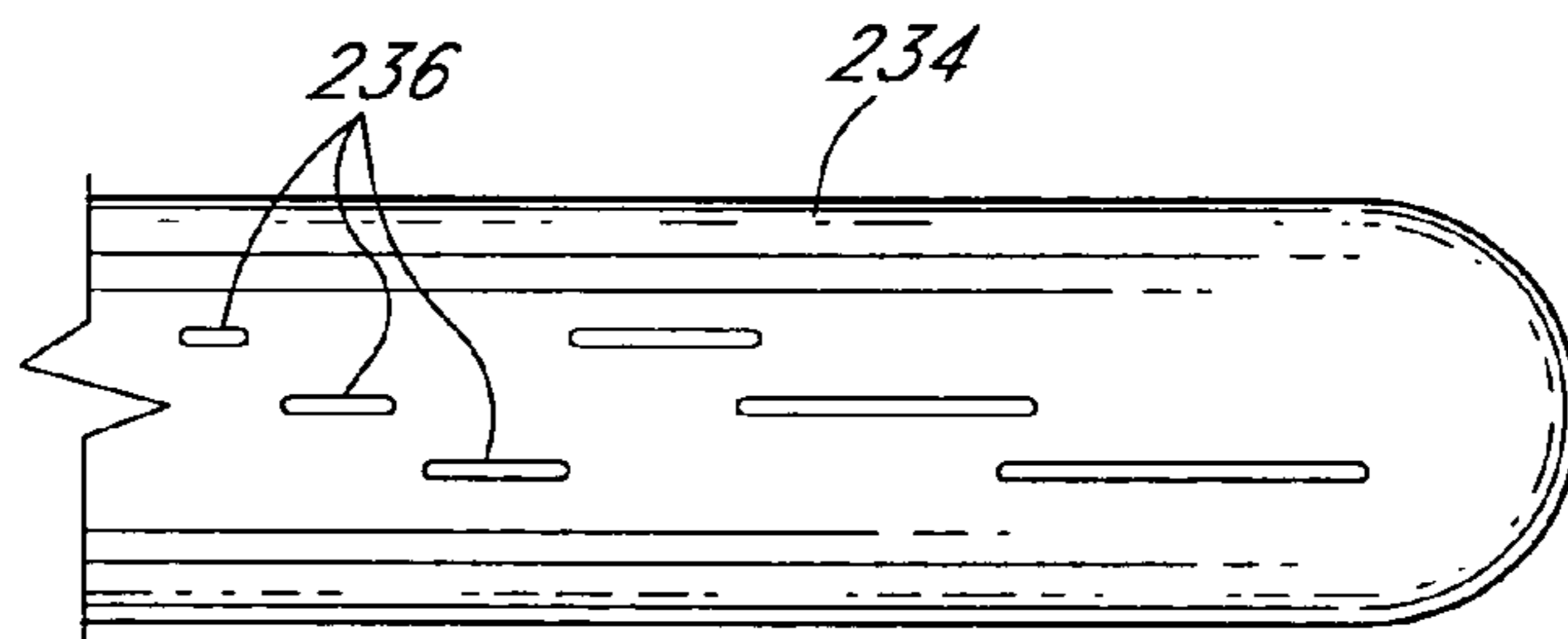

FIG. 21

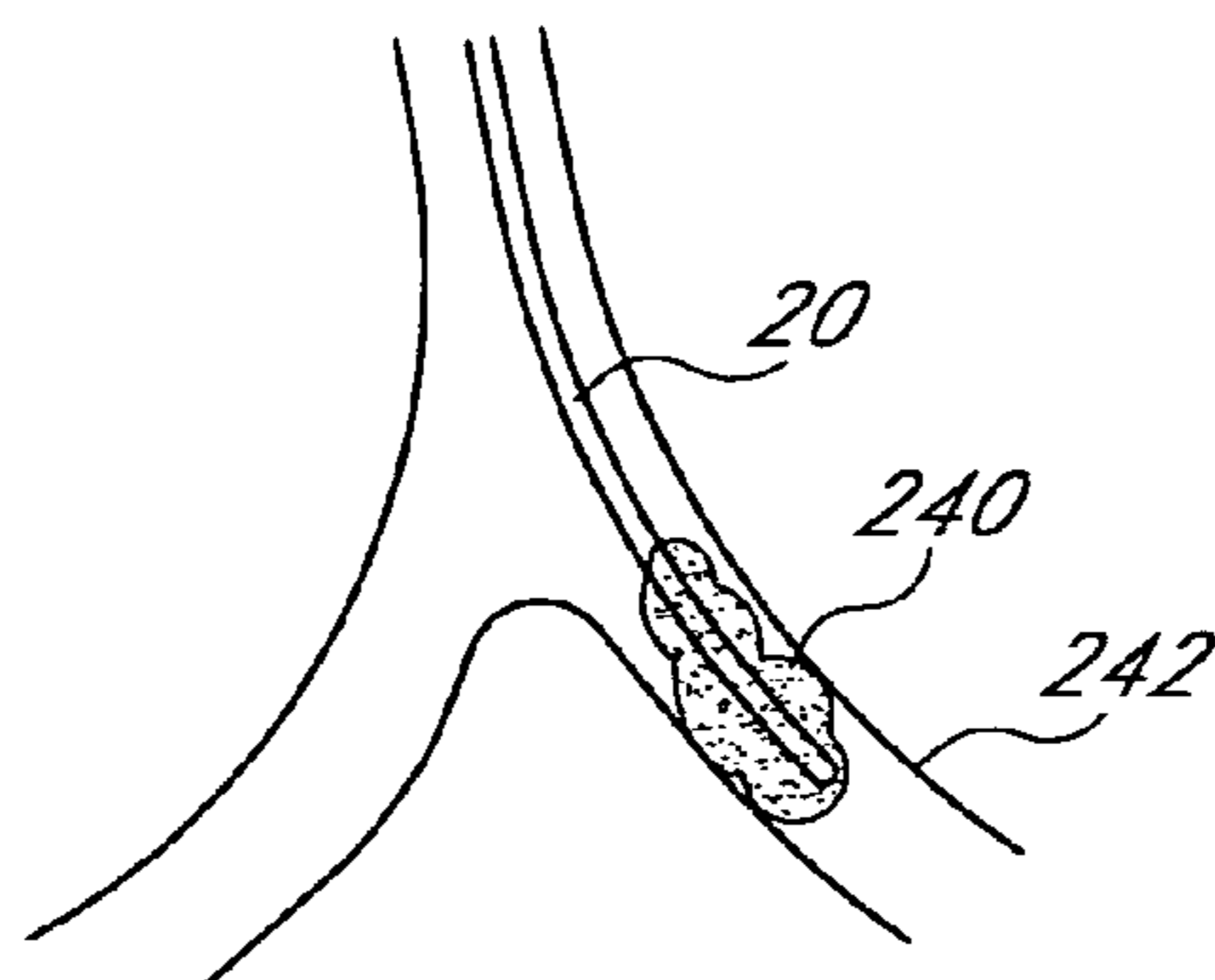
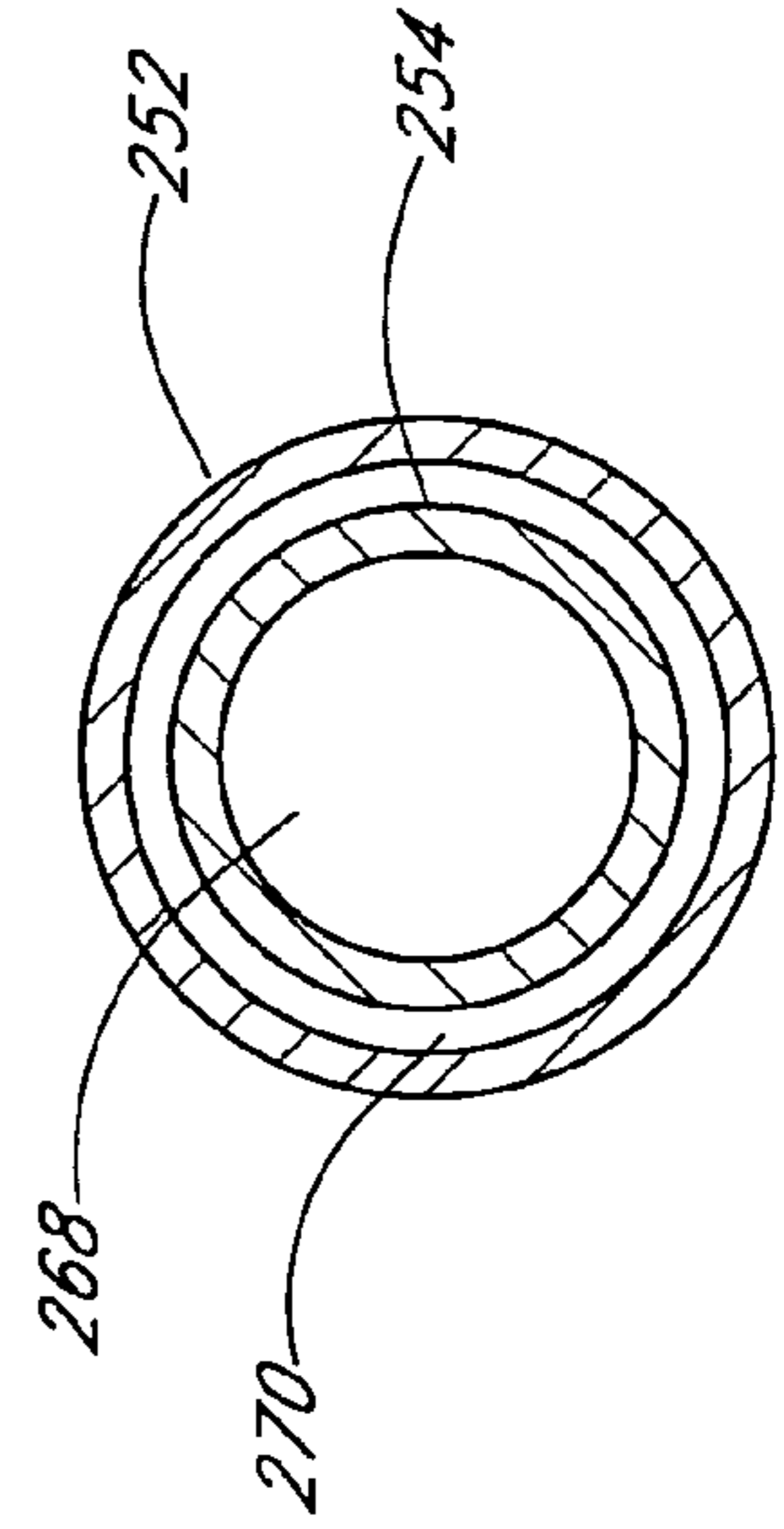
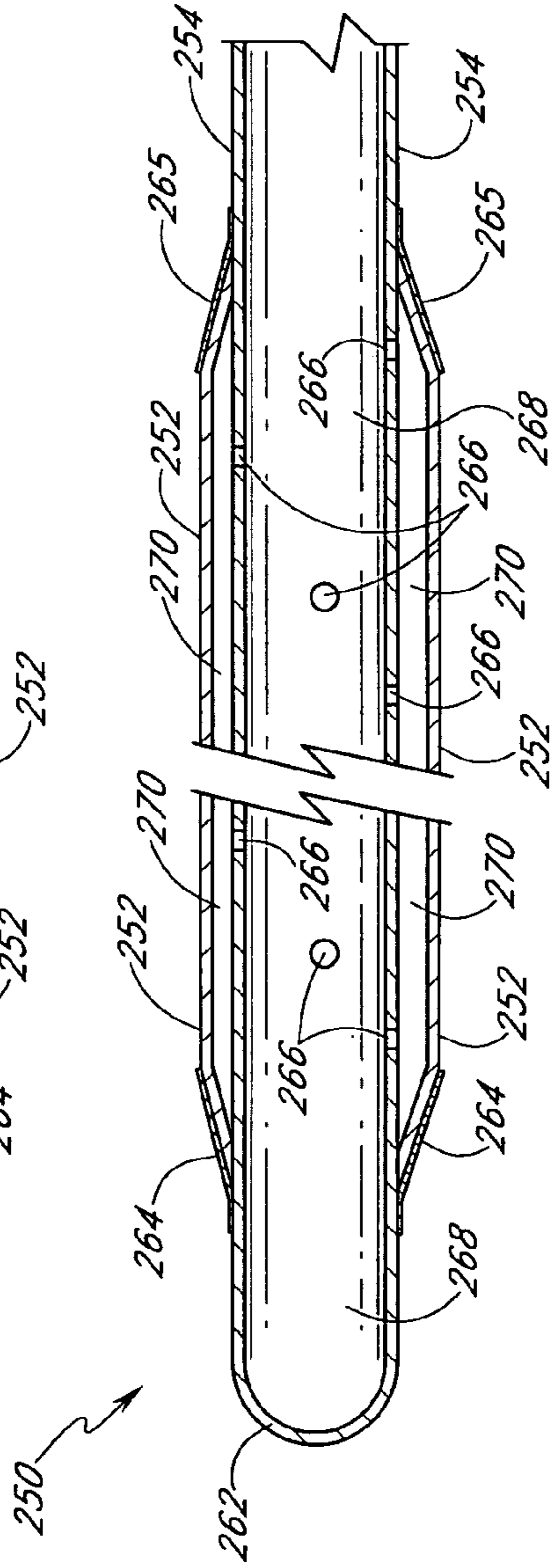
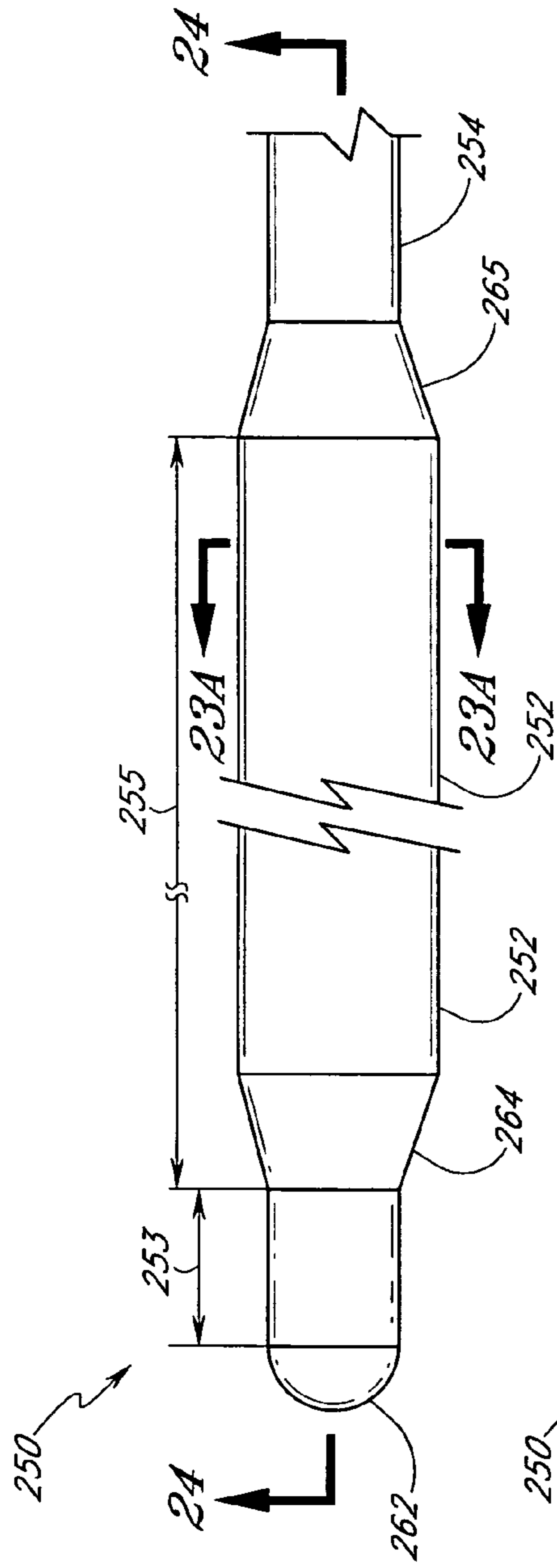

FIG. 22



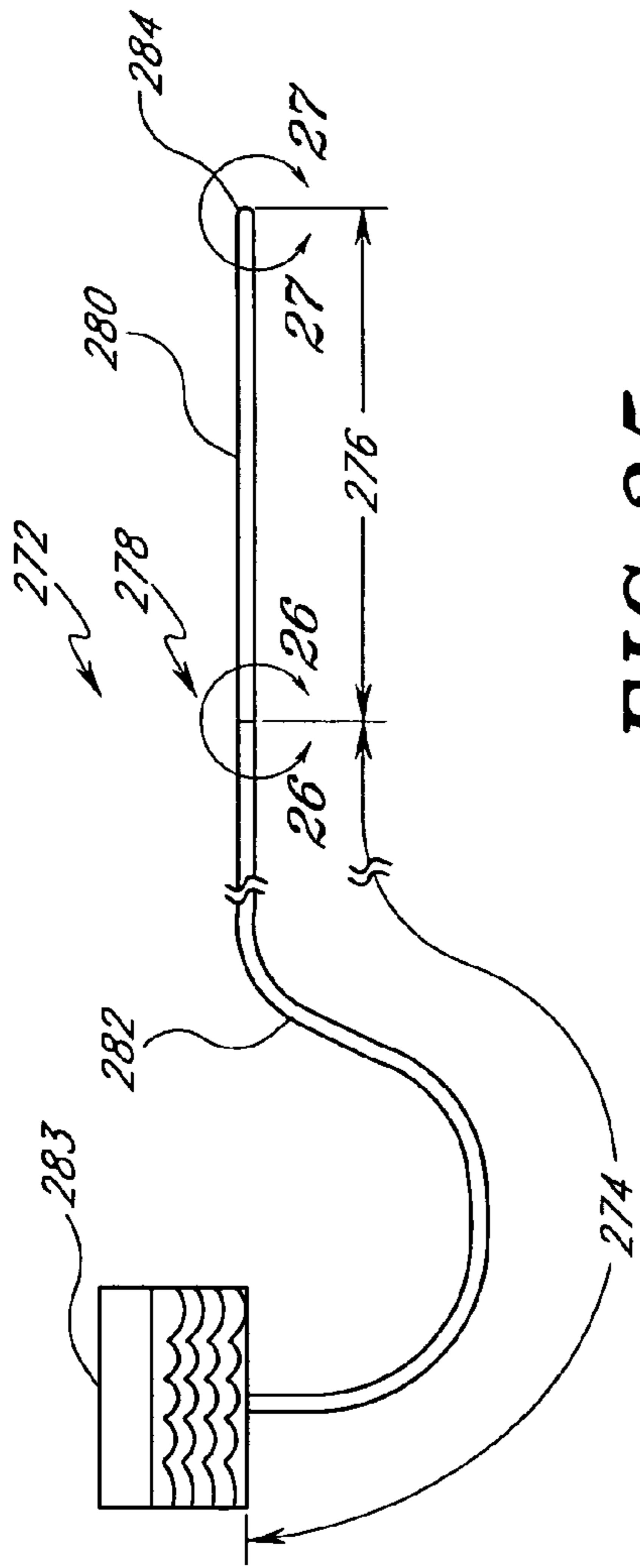

FIG. 25

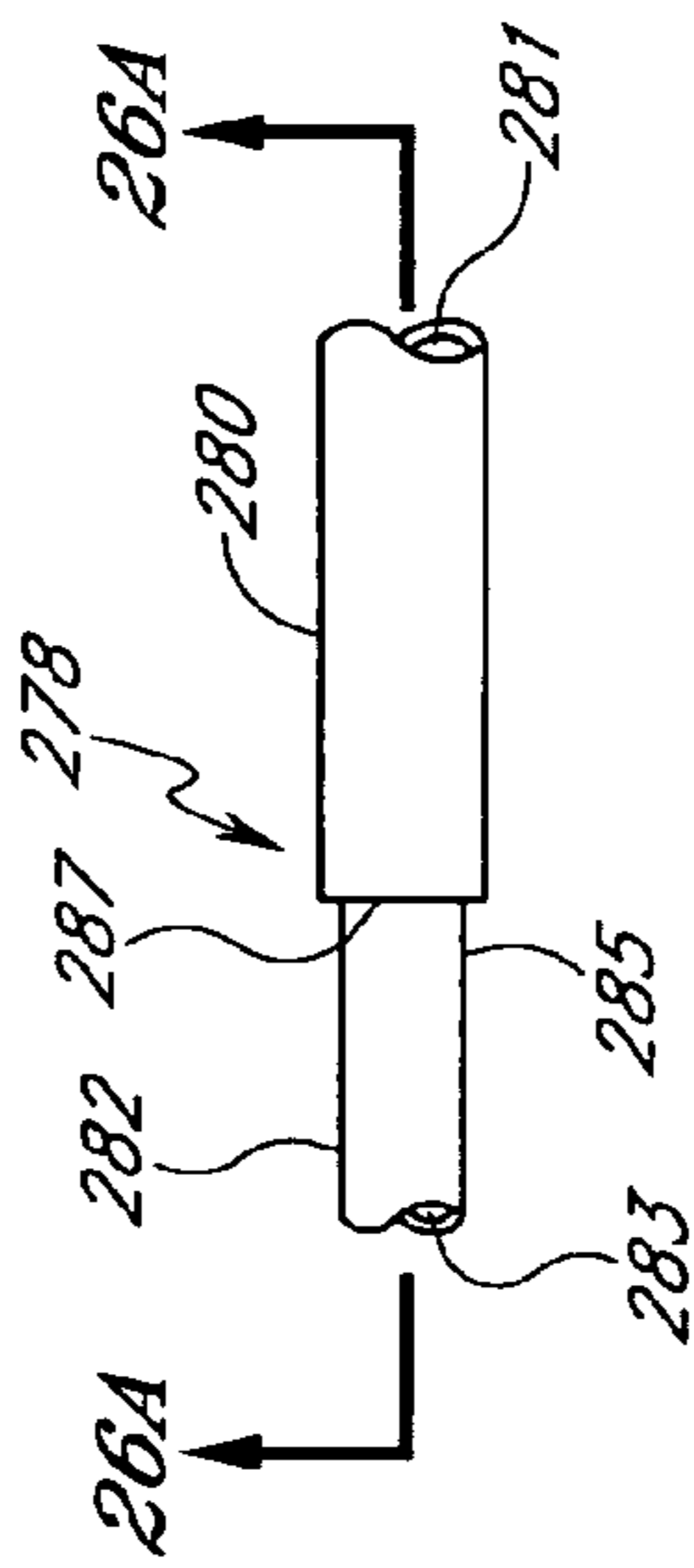

FIG. 26

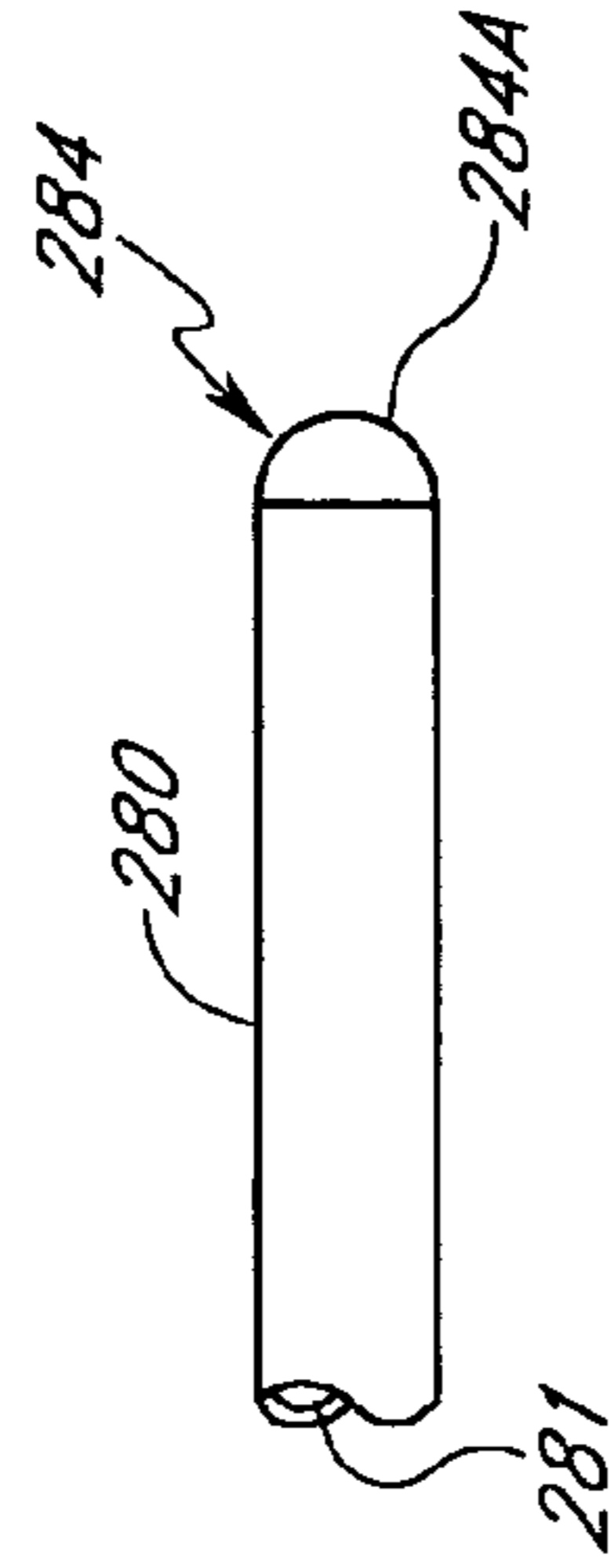

FIG. 27

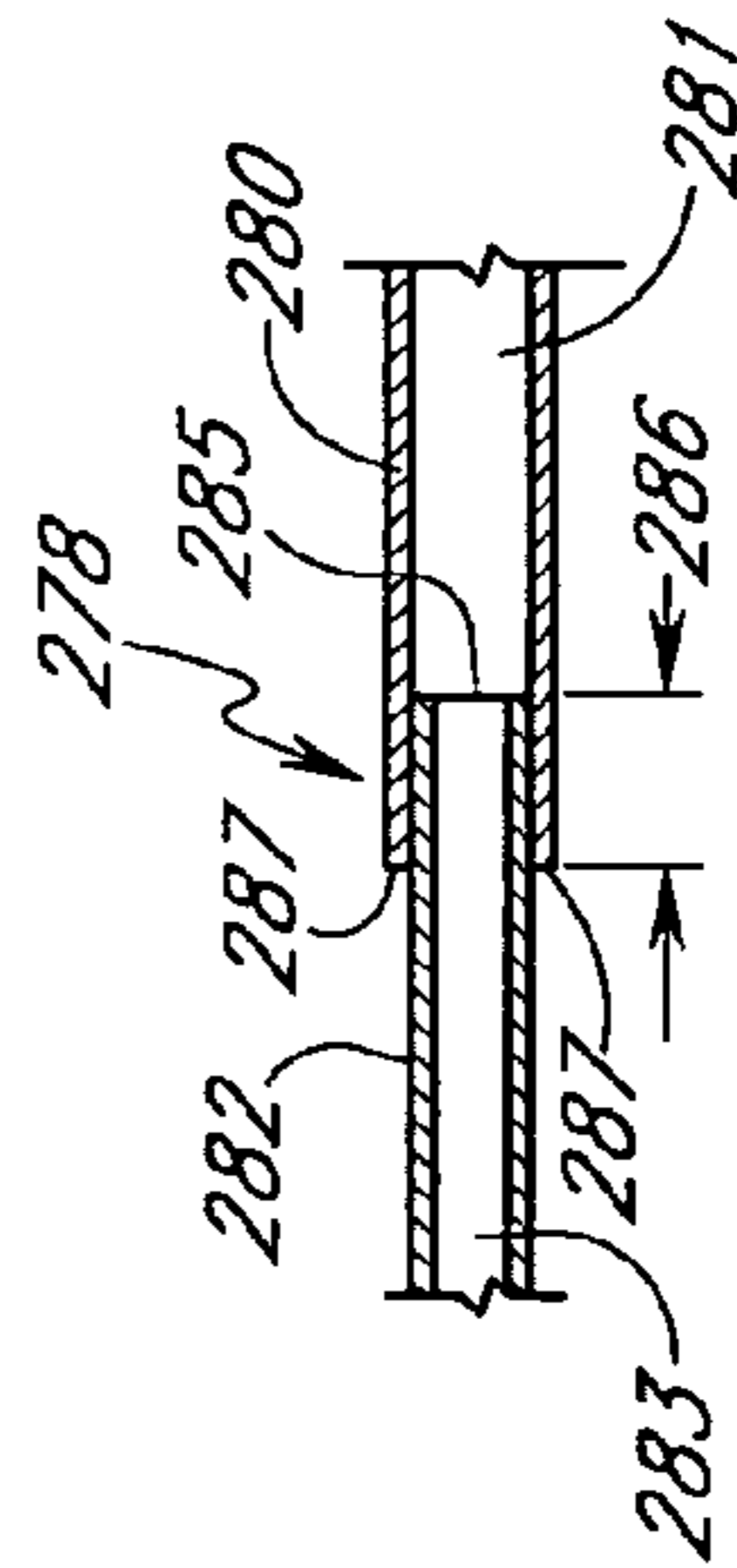

FIG. 26A

CATHETER FOR UNIFORM DELIVERY OF MEDICATION

RELATED APPLICATION

This application is a continuation-in-part of pending U.S. patent application Ser. No. 10/031,913, filed May 21, 2002, which is a U.S. National Phase of International Patent Application No. PCT/US00/19746, filed Jul. 19, 2000, which is a continuation-in-part U.S. patent application Ser. No. 09/363,228, filed Jul. 19, 1999, now U.S. Pat. No. 6,350,253, the entireties of which are hereby incorporated by reference.

BACKGROUND OF THE INVENTION

1. Field of the Invention

This invention generally relates to catheters and, in particular, to a catheter that delivers fluid medication uniformly across an infusion section of the catheter.

2. Description of the Related Art

Infusion catheters for delivery of fluid medication into anatomical systems, such as the human body, are well known in the art. Such catheters generally include a flexible hollow tube inserted into some region of the anatomy. The tube typically contains one or more axial lumens within which the fluid may flow. The proximal end of the catheter tube is connected to a fluid source from which fluid is introduced into the catheter tube. The fluid flows within one of the lumens under pressure supplied at the proximal end of the tube. For each lumen, there are commonly provided one or more exit holes along an infusion section near the distal end of the tube, for fluid to exit the tube. Such exit holes are created by piercing the side wall of the hollow tube.

In certain medical conditions, it is advantageous to deliver fluid medication to a plurality of sites within a wound area. For instance, some wounds which require pain medication may be in communication with many nerve endings, rather than a single nerve trunk. One example of such a wound is a surgical incision. As stated above, it is known to provide a plurality of exit holes through which the fluid medication exits the catheter tube. The exit holes may be provided at various axial and circumferential positions along the catheter tube in order to control the position of the medication delivery sites. An example of a catheter having this configuration is disclosed in U.S. Pat. No. 5,800,407 to Eldor. Also, in some cases it is desirable to deliver such medication under low pressure, so that the fluid is delivered at a relatively low rate. For example, some pain medications must be delivered slowly to avoid toxicity and other side effects. Furthermore, in many cases it is desirable to dispense fluid medication at a substantially uniform rate throughout the infusion section of the catheter, so that the medication is evenly distributed throughout the wound area.

Unfortunately, a limitation of prior art catheters with multiple exit holes, such as the catheter taught by Eldor, is that during low pressure delivery of fluid medication the fluid tends to exit only through the exit hole(s) nearest to the proximal end of the infusion section of the catheter tube. This is because fluids flowing through a tube more readily exit through the exit holes offering the least flow resistance. The longer the flow path followed by the fluid in the lumen, the higher the flow resistance and pressure drop experienced by the fluid. The most proximal holes offer the least flow resistance and pressure drop. Therefore, the fluid tends to exit the catheter tube primarily through these exit holes. As a result, the fluid medication is delivered only to a small region within the wound area. The tendency of the fluid to undesirably flow

only through the most proximal exit holes depends upon the hole size, the total number of exit holes, and the flow rate. As the hole size or number of holes increases, the fluid becomes more likely to exit only through the most proximal holes. Conversely, as the flow rate increases, the fluid becomes less likely to do so.

The tendency of the fluid to undesirably exit only through the most proximal holes of the catheter can in some cases be overcome by increasing the flow rate or pressure of the fluid, which causes the fluid to flow through more of the exit holes of the catheter. Indeed, if the flow rate or pressure is sufficiently high, the fluid will flow through all of the exit holes. However, sometimes it is medically desirable to deliver medication at a relatively slow rate, i.e., at a low pressure. Also, even in those cases in which high pressure fluid delivery is acceptable or desirable, prior art catheters do not provide for uniform fluid delivery along the infusion section of the catheter. Rather, the flow rate through the exit holes nearer to the proximal end of the infusion section tends to be greater than that through the exit holes nearer to the distal end. This is because the fluid passing through the more proximal holes experiences a lower flow resistance and pressure drop. In contrast, the fluid flowing through the more distal holes experiences greater flow resistance and pressure drop, and consequently exits at a lower flow rate. The further distal the hole, the lower the exit flow rate of the fluid. As a result, there is an uneven distribution of medication throughout the wound area.

In another known type of infusion catheter, several lumens are provided within a catheter tube. For each lumen, one exit hole is provided by piercing a hole within the wall of the tube. The exit holes are provided at different axial positions along the infusion section of the catheter tube. In this manner, fluid medication may be delivered to several positions within the wound area. While this configuration offers improved fluid distribution, it has some disadvantages. One disadvantage is that the fluid flow rates through the exit holes are not equal, since the more distal exit holes offer a greater flow resistance for the same reasons discussed above. Another disadvantage is that the number of lumens, and consequently the number of fluid exit holes, is limited by the small diameter of the catheter tube. As a result, fluid may be delivered only to a very limited number of positions within the wound area. Yet another disadvantage is that the proximal ends of the lumens must be attached to a complicated manifold which increases the cost of manufacturing the catheter.

An example of a catheter providing a more uniform dispensation of fluid medication throughout an infusion section of the catheter is illustrated by U.S. Pat. No. 5,425,723 to Wang. Wang discloses an infusion catheter including an outer tube, an inner tube concentrically enclosed within the outer tube, and a central lumen within the inner tube. The inner tube has a smaller diameter than the outer tube, so that an annular passageway is formed therebetween. The outer tube has a plurality of evenly spaced exit holes defining the infusion section of the catheter. In use, fluid flowing within the central lumen passes through strategically positioned side holes within the side walls of the inner tube. In particular, the spacing between adjacent side holes decreases along a length of the inner tube to induce more fluid to pass through the more distal side holes. The fluid then flows longitudinally through the annular passageway before exiting through the exit holes in the outer tube wall. In the annular passageway, the fluid can flow in a distal or proximal direction, depending on the location of the nearest exit hole in the outer tube. This configuration is provided to induce a more uniform exit flow rate of fluid from the catheter.

Unfortunately, the Wang catheter is only effective for relatively high pressure fluid delivery. When used for relatively low pressure fluid delivery, the catheter disclosed by Wang does not provide uniform dispensation of fluid. Instead, the fluid tends to exit through the side holes of the inner and outer tubes that are nearest to the proximal end of the infusion section of the catheter, since these holes offer the least flow resistance. Even for high pressure fluid delivery, there are several limitations of this design. One limitation is that the concentric tubes design is relatively complex and difficult to manufacture. Both tubes must be flexible enough to permit maneuverability through an anatomical system, yet the annular passageway must remain open so that fluid may flow uniformly therein. Another limitation is that the annular passageway may be disturbed if there is a bend in the infusion section of the tube. A bend in the catheter may deform the annular passageway or even cause the inner and outer tubes to come into contact. This can cause an uneven fluid pressure within a longitudinal cross-section of the annular passageway, resulting in non-uniform fluid delivery.

Thus, there is a need for an improved infusion catheter for delivering fluid medication uniformly along its infusion section in a relatively simple, easy to manufacture design which is effective for both high flow rate and low flow rate fluid delivery. Furthermore, it is recognized that a particular class of catheters, such as the Wang catheter, may provide uniform fluid delivery only at high fluid pressure or flow rates. However, there is a need for an infusion catheter belonging to this class that has a relatively simple, easy to manufacture design and can maintain uniform fluid delivery while bent or otherwise physically deformed.

SUMMARY OF THE INVENTION

Accordingly, it is a principle object and advantage of the present invention to overcome some or all of these limitations and to provide an improved catheter for delivering fluid medication to a wound area of an anatomical region.

A catheter is provided for uniform distribution of fluid medication within an anatomical region. One embodiment of the catheter is comprised of an elongated tube and an outer elongated tubular porous membrane which encloses a length of the elongated tube such that an annular space exists between tubular membrane and the elongated tube. The tubular membrane is comprised of a highly porous material, preferably having an average pore diameter ranging between about 0.1 microns and about 0.5 microns. One embodiment of the catheter has an average pore diameter which is particularly suited for filtration of bacteria. A plurality of fluid exit holes are provided within the portion of the elongated tube enclosed within the tubular membrane. In operation, fluid within the catheter flows through the all of the exit holes into the annular space. The tubular membrane ensures that the fluid is uniformly distributed within the anatomical region.

In accordance with one embodiment of the present invention a catheter is provided for the uniform delivery of fluid across an anatomical region, comprising an elongated tubular member made of a porous membrane. The membrane is sized to be inserted through a subcutaneous layer surrounding the anatomical region, such as a person's skin. The membrane is configured so that a fluid introduced under pressure into an open end of the tubular member will flow through side walls of the tubular member at a substantially uniform rate along a length of the tubular member. The present invention also provides a method of uniformly delivering fluid throughout an anatomical region, comprising the steps of inserting the

elongated tubular member into the anatomical region and introducing a fluid under pressure into an open end of the tubular member.

Another embodiment of the present invention provides a catheter and method for the uniform delivery of fluid throughout an anatomical region. The catheter comprises an elongated support and a porous membrane wrapped around the support. The support is configured so that one or more lumens are formed between the support and the membrane. Alternatively, the support may be a tubular member having a plurality of holes therein. The method comprises the steps of inserting the above-described catheter into the anatomical region and introducing a fluid under pressure into the proximal end of at least one of the lumens. Advantageously, the fluid passes through the membrane at a substantially uniform rate into the anatomical region. The present invention further provides a method of manufacturing this catheter comprising the steps of forming an elongated support and wrapping a porous membrane around the support so that one or more lumens are formed between the support and the membrane.

Another embodiment of the present invention provides a catheter and method for the uniform delivery of fluid throughout an anatomical region. The catheter comprises an elongated tube including a plurality of exit holes along a length thereof and a tubular porous membrane concentrically enclosed within the tube. The tube and membrane define a lumen. The method comprises the steps of inserting the above-mentioned catheter into the anatomical region and introducing a fluid under pressure into the proximal end of the lumen so that the fluid advantageously passes through the membrane and the exit holes at a substantially uniform rate into the anatomical region. The present invention further provides a method of manufacturing this catheter, comprising the steps of forming an elongated tube, providing a plurality of exit holes along a length of the tube, forming a tubular porous membrane, and concentrically enclosing the tubular porous membrane within the tube so that the tube and membrane define a lumen.

Yet another embodiment of the present invention provides a device and method for the uniform delivery of fluid throughout an anatomical region. The device is advantageously simple and easy to manufacture, comprising an elongated catheter having a plurality of exit holes along a length thereof. The exit holes may serve as the flow-restricting orifice. Alternatively, a flow-restricting orifice may be provided elsewhere within the catheter or proximal to the catheter. The exit holes may gradually increase in size along the length of the catheter, so that the largest exit hole is further distal than the smallest exit hole. Alternatively, the holes can be laser drilled and be of approximately the same size. Advantageously, a fluid flowing under pressure within the catheter will flow through substantially all of the exit holes at a substantially equal rate. The method comprises the steps of inserting the catheter into the anatomical region and introducing a fluid under pressure into the proximal end of the catheter. The fluid flows through the exit holes and enters the anatomical region, advantageously flowing through substantially all of the exit holes at a substantially equal rate. The present invention further provides a method of manufacturing this device, comprising the steps of forming an elongated catheter and providing a plurality of exit holes along a length of the catheter in a manner so that the exit holes gradually increase in size along the length of the catheter from the proximal end to the distal end thereof.

Yet another embodiment of the present invention provides a catheter and method for delivering fluid medication to an anatomical region. The catheter comprises a tube, a "weeping" tubular coil spring attached to a distal end of the tube, and

5

a stop closing a distal end of the spring. The tube and spring each define a portion of a central lumen. The spring has adjacent coils in contact with one another so that fluid within the spring and below a threshold dispensation pressure is prevented from exiting the lumen by flowing radially between the coils. The spring has the property of stretching when the fluid pressure is greater than or equal to the threshold dispensation pressure permitting the fluid to be dispensed from the lumen by flowing radially between the coils, i.e. “weeping” through the spring. Alternatively, the fluid may weep through imperfections in the spring coil. Advantageously, the fluid is dispensed substantially uniformly throughout the length and circumference of a portion of the spring. In use, fluid is introduced into an open proximal end of the tube, allowed to flow into the spring, and brought to a pressure greater than or equal to the threshold dispensation pressure so that the fluid weeps through the spring.

Yet another embodiment of the present invention provides a catheter and method for delivering fluid medication to an anatomical region. The catheter comprises a distally closed tube and a “weeping” tubular coil spring, as described above, enclosed within the tube. A plurality of exit holes are provided in side walls along a length of the tube, defining an infusion section of the tube. The spring is enclosed within the infusion section so that a lumen is defined within the tube and spring. In use, fluid is introduced into a proximal end of the tube, allowed to flow into the spring, and brought to a pressure greater than or equal to the threshold dispensation pressure of the spring so that the fluid is dispensed from the lumen by weeping through the spring and then flowing through the exit holes of the tube.

Yet another embodiment of the present invention provides a catheter comprising an elongated tube and a solid flexible member positioned within the tube. The tube has a closed distal end and a plurality of exit holes in side walls of the tube. The exit holes are provided along a length of the tube defining an infusion section of the catheter. The tube is sized to be inserted into an anatomical region. The member is positioned within the tube and is sized so that an annular space is formed between the tube and the member. The member is formed of a porous material. Advantageously, the catheter is configured so that a fluid introduced into a proximal end of the tube will flow through the exit holes at a substantially uniform rate throughout the infusion section.

In yet another embodiment, the present invention provides a catheter comprising an elongated tube having a plurality of exit slots in side walls of the tube. The slots are provided along a length of the tube defining an infusion section of the catheter. The exit slots are oriented generally parallel to the longitudinal axis of the tube. Advantageously, the tube is configured so that a fluid flowing therein will flow through substantially all of the exit slots at a substantially equal rate. In one optional aspect, the slots increase in length from the proximal to the distal ends of the infusion section.

In yet another embodiment, the present invention involves a catheter for delivering a fluid to an anatomical region. The catheter includes an elongate tubular catheter body defining a distally-closed lumen. A portion of the catheter body has a plurality of openings extending through a side wall of the catheter body thereby defining an infusion section of the catheter. A tubular sheath, constructed from a porous material, is positioned over the infusion section and extends at least a length of the infusion section. The tubular sheath and the catheter body are configured such that fluid within the lumen must pass through the tubular sheath to exit the catheter. A pore size of the porous material is less than about 0.5 microns.

6

Yet another embodiment of the invention involves a catheter for delivering a fluid to an anatomical region. The catheter includes an elongate tubular catheter body having a side wall, wherein an outer surface of the side wall defines a relatively uniform first diameter. The catheter body also includes a lumen. A distal portion of the catheter body permits fluid to pass from within the lumen to external of the catheter body, thereby defining an infusion section of the catheter. A tubular sheath, constructed from a porous material, has a side wall, a first end and a second end. The tubular sheath is positioned over the infusion section such that the infusion section is between the first end and the second end. An inner surface of the side wall of the tubular sheath defines a second diameter sized to create an interstitial space between the tubular sheath and the catheter body. The first end and the second end of the tubular sheath are bonded to the outer surface of the catheter body to substantially seal the interstitial space.

In yet another embodiment, the present invention involves a catheter for delivering a fluid to an anatomical region. The catheter includes an elongated, proximal tube defining a lumen. An elongated, distal tube, constructed from a bio-absorbable material, defines a lumen that communicates with the lumen of the proximal tube. At least a portion of the distal tube permits communication of the fluid from within the lumen to external of the distal tube, thereby defining an infusion section of the catheter. A proximal end portion of the distal tube and a distal end portion of the proximal tube overlap one another. The proximal end portion of the distal tube is bonded to the distal end portion of the proximal tube with a bio-compatible adhesive to create a substantially fluid-tight joint therebetween. A length of an overlapping portion of the proximal tube and the distal tube is at least about 0.02 inches and, more preferably, about 0.03 inches.

Yet another embodiment of the present invention involves a catheter for delivering a fluid to an anatomical region comprising an elongated, proximal tube defining a lumen. An elongated, distal tube has a closed end and is constructed from a bio-absorbable material. The distal tube defines a lumen, which communicates with the lumen of the proximal tube. At least a portion of the distal tube defines a porous side wall permitting fluid within the lumen to pass through the portion of the distal tube.

A further aspect of the present invention involves a method for delivering a fluid throughout an anatomical region of a patient. The method includes inserting an elongate, tubular member into an incision of the patient, wherein the tubular member has a proximal portion attached to a distal portion at a joint. The distal portion comprises a bio-absorbable material. At least a portion of a side wall of the distal portion defines a porous membrane adapted to permit fluid within the tubular member to pass through the side wall. The method further includes positioning the tubular member such that the joint is within the patient, closing the incision and introducing fluid into an open proximal end of the tubular member.

For purposes of summarizing the invention and the advantages achieved over the prior art, certain objects and advantages of the invention have been described herein above. Of course, it is to be understood that not necessarily all such objects or advantages may be achieved in accordance with any particular embodiment of the invention. Thus, for example, those skilled in the art will recognize that the invention may be embodied or carried out in a manner that achieves or optimizes one advantage or group of advantages as taught herein without necessarily achieving other objects or advantages as may be taught or suggested herein.

All of these embodiments are intended to be within the scope of the invention herein disclosed. These and other embodiments of the present invention will become readily apparent to those skilled in the art from the following detailed description of the preferred embodiments having reference to the attached figures, the invention not being limited to any particular preferred embodiment(s) disclosed.

BRIEF DESCRIPTION OF THE DRAWINGS

FIG. 1 is a schematic side view of a catheter having features and advantages in accordance with a first embodiment of the present invention.

FIG. 2 is a sectional view of the catheter of FIG. 1, taken along line 2-2 of FIG. 1.

FIG. 3 is a sectional view of the catheter of FIG. 1, taken along line 3-3 of FIG. 1.

FIG. 4 is a perspective view of the end portion and support beam of the catheter of FIG. 1, illustrating a cross-section taken along line 4-4 of FIG. 1.

FIG. 5 is a side view of a catheter having features and advantages in accordance with a second embodiment of the present invention.

FIG. 6 is a cross-sectional view of the infusion section of the catheter of FIG. 5 taken along line 6-6 of FIG. 5.

FIG. 7 is a cross-sectional view of a catheter having features and advantages in accordance with a third embodiment of the present invention.

FIG. 8 is a side view of a catheter having features and advantages in accordance with a fourth embodiment of the present invention.

FIG. 9 is a side view of a catheter having features and advantages in accordance with a fifth embodiment of the present invention.

FIG. 10A is a cross-section view of the catheter of FIG. 9, illustrating an unstretched state of the spring.

FIG. 10B is a cross-sectional view of the catheter of FIG. 9, illustrating a stretched state of the spring.

FIG. 11 is a cross-sectional view of a catheter having features and advantages in accordance with a sixth embodiment of the present invention.

FIG. 12 is a side view of a catheter having features and advantages in accordance with the sixth embodiment of the present invention.

FIG. 13 is a longitudinal cross-sectional view of a catheter having features and advantages in accordance with a seventh embodiment of the present invention.

FIGS. 14-16 are longitudinal cross-sectional views of catheters similar to that of FIG. 13, illustrating alternative attachments between the internal porous member and the tube.

FIG. 17 is a transverse cross-sectional view of a catheter according to FIGS. 13-16, wherein the internal porous member is concentric with the outer tube.

FIG. 18 is a transverse cross-sectional view of a catheter according to FIGS. 13-16, wherein the internal porous member is not concentric with the outer tube.

FIG. 19 is a schematic illustration of a catheter of the present invention used in conjunction with an air eliminating filter.

FIG. 20 is a side view of a catheter having features and advantages in accordance with an eighth embodiment of the present invention.

FIG. 21 is a side view of a catheter having features and advantages in accordance with a ninth embodiment of the present invention.

FIG. 22 is a schematic illustration of the use of a catheter of the present invention for treating a blood clot.

FIG. 23 is side elevation view of a catheter having features and advantages in accordance with a tenth embodiment of the present invention, which includes a tubular porous membrane, or sheath.

FIG. 23A is a cross-sectional view of the catheter of FIG. 23, taken along line 23A-23A.

FIG. 24 is a cross-sectional view of the catheter of FIG. 23, taken along line 24-24.

FIG. 25 is a schematic side view of a catheter having features and advantages in accordance with an eleventh embodiment of the present invention, wherein at least a portion of the catheter is constructed from a bio-absorbable material.

FIG. 26 is an enlarged side view of a junction between a non-porous section and a bio-absorbable section of the catheter of FIG. 25.

FIG. 26A is a cross-sectional view of the junction of FIG. 26, taken along line 26A-26A.

FIG. 27 is an enlarged side view of distal end of the catheter of FIG. 25.

DETAILED DESCRIPTION OF THE PREFERRED EMBODIMENT

FIGS. 1-4 illustrate an infusion catheter 20 according to one embodiment of the present invention. Catheter 20 preferably includes a flexible support 22 (FIGS. 2-4), a non-porous membrane 24, and a porous membrane 26. The membranes 24 and 26 are wrapped around the support 22 to form a plurality of axial lumens between the inner surfaces of the membranes 24 and 26 and the surface of the support 22, as described in greater detail below. The non-porous membrane 24 defines a non-infusing section 28 of the catheter 20, and preferably covers the support 22 from the proximal end thereof to a point 30, shown in FIG. 1. Similarly, the porous membrane 26 defines an infusion section 32 of catheter 20, and preferably covers the support 22 from the point 30 to the distal end of support 22. Alternatively, the catheter 20 may be configured without a non-porous membrane 24. In this configuration, the porous membrane 26 covers the entire length of the support 22, so that the entire length of the support 22 corresponds to the infusion section of the catheter 20. The infusion section can have any desired length. The proximal end of the catheter 20 may be connected to a fluid supply 34 containing a fluid 36 such as a liquid medication. The distal end of catheter 20 may include a cap 48 (FIG. 4) defining the endpoint of the axial lumens within the catheter 20.

In use, the catheter 20 is inserted into an anatomical system, such as a human body, to deliver fluid medication directly to a wound area within the anatomical system. In particular, the catheter 20 is designed to deliver medication throughout a generally linear segment of the wound area, corresponding to the infusion section 32 of the catheter 20. Thus, the catheter is preferably inserted so that the infusion section 32 is positioned within the wound area. By using well known methods, a physician or nurse may insert the catheter 20 with the aid of an axial guide wire 46 positioned within an axial guide wire lumen 44 of the catheter. Once the catheter is positioned as desired, the guide wire 46 is simply pulled back out through the proximal end of the catheter 20. Alternatively, the catheter 20 may be provided without a guide wire or a guide wire lumen.

FIGS. 2 and 3 illustrate a preferred configuration of the support 22. The surface of the support 22 includes interruptions such as a plurality of ribs 40 as shown in the figures. The interruptions are configured so that when the membranes 24 and 26 are wrapped around the support 22, the membranes

form a portion of the walls of a plurality of axial lumens 38 within which the fluid 36 may flow. In a preferred configuration, a plurality of ribs 40 extend radially from a common axial center portion 42 of the support 22. The ribs 40 also extend longitudinally along a length of the support 22, and preferably along the entire length thereof. In the non-infusing section 28, shown in FIG. 2, the non-porous membrane 24 is preferably tightly wrapped around the outer edges of the ribs 40. As a result, the axial lumens 38 are formed between the inner surface of the non-porous membrane 24 and the outer surface of support 22. Similarly, in the infusion section 32, shown in FIG. 3, the porous membrane 26 is preferably tightly wrapped around the outer edges of the ribs 40, so that the axial lumens 38 are formed between the inner surface of porous membrane 26 and the outer surface of support 22.

In an alternative embodiment of the catheter 20, the porous membrane 26 may be wrapped around the entire length of the support 20, thus replacing the non-porous membrane 24. In this embodiment, the entire length of the support 22 corresponds to the infusion section 32. According to another alternative embodiment, the support 22 may extend only within the infusion section 32, and a tube may be provided extending from the fluid supply 34 to the proximal end of the support 22. In this embodiment, the tube replaces the non-porous membrane 24 and the portion of the support 22 extending within the non-infusing section 28 of the preferred embodiment. In other words, the tube defines the non-infusing section 28.

In the preferred configuration, the number of ribs 40 equals the number of axial lumens 38. Although five ribs 40 and axial lumens 38 are shown in FIGS. 2 and 3, any suitable number of ribs 40 and lumens 38 may be provided, giving due consideration to the goals of providing a plurality of lumens within the catheter 20, maintaining flexibility, and, if desired, maintaining the fluid independence of the lumens. Herein, the terms "fluid independence," "fluid separation," and the like, when used to describe a plurality of axial lumens, simply mean that the lumens do not fluidly communicate with each other. The membranes 24 and 26 are preferably glued along the outer edges of the ribs 40, utilizing any suitable glue, such as a medical grade glue or epoxy. This prevents the membranes 24 and 26 from slipping, which might occur as the catheter is inserted or removed from the anatomy. More preferably, the membranes are glued along the entire length of the outer edges of each of the ribs 40. Alternatively, the membrane may be wrapped around the support and not secured to the support by a foreign substance. The membrane and support may also be secured to each other by other means known to those of skill in the art. This maintains the fluid independence of the lumens 38. If desired, an axial guide wire lumen 44 may be provided within the axial central portion 42 of the support 22. The guide wire lumen 44 is adapted to receive a guide wire 46 which may be used to aid in the insertion of the catheter 20 into the anatomy, as described above and as will be easily understood by those of skill in the art.

As shown in FIG. 4, the catheter 20 preferably includes an end portion or cap 48 secured to the distal end of support 22. End portion 48 may be formed integrally with the support 22 or may be adhesively bonded thereto. Preferably, the proximal end of end portion 48 is circular and has a diameter such that the outer surface of the proximal end of end portion 48 is aligned with the outer edges of the ribs 40 of the support 22, as shown. The porous membrane 26 is wrapped around the proximal end of the end portion 48. The membrane 26 is preferably glued to the end portion 48 so that fluid 36 within the lumens 38 is prevented from exiting the catheter 20 without passing through the walls of the membrane 26. End portion 48 blocks axial fluid flow through the distal end of cath-

eter 20. However, end portion 48 may optionally be formed from a porous material to permit some axial dispensation of fluid from the distal end of the catheter 20, if desired. The distal end of end portion 48 is preferably dome-shaped, as shown, to permit the catheter 20 to more easily be inserted into an anatomical region.

The support 22 can be formed from a variety of materials, giving due consideration to the goals of flexibility, lightweight, strength, smoothness, and non-reactivity to anatomical systems, i.e., safety. Suitable materials for the support 22 include nylon, polyamide, Teflon, and other materials known to those skilled in the art. The porous membrane 26 is preferably a sponge-like or foam-like material or a hollow fiber. The membrane 26 may be formed from a variety of suitable materials, giving due consideration to the goals of being flexible and non-reactive to anatomical systems. The membrane 26 preferably has a porosity resulting in substantially uniform dispensation of fluid along the surface area of the infusion section 32 of the catheter 20, and has an average pore size sufficiently small to limit the flow of bacteria through the membrane walls. Some suitable materials for the membrane 26 are polyethylene, polysulfone, polyethersulfone, polypropylene, polyvinylidene difluoride, polycarbonate, nylon, or high density polyethylene. These materials are advantageously biocompatible. The porous membrane 26 may filter out unwanted bacteria from the fluid medication as it passes through the membrane 26. It is known that the smallest bacteria cannot pass through a pore any smaller than 0.23 microns. Thus, the average pore size, or pore diameter, of the porous membrane 26 may be less than 0.23 microns to prevent bacteria from traversing the membrane 26. The average pore size, or pore diameter, of the membrane 26 is preferably within the range of about 0.1 to 1.2 microns, more preferably within the range of about 0.3 to 1 micron, and even more preferably about 0.8 microns.

As mentioned above, the proximal end of catheter 20 may be connected to a fluid supply 34. The catheter 20 may be configured so that each axial lumen 38 is fluidly independent. In other words, the lumens 38 would not fluidly communicate with one another. The catheter 20 may be connected to a single fluid supply 34, so that the fluid 36 flows within each of the lumens 38. Alternatively, the catheter 20 may be connected to a plurality of separate fluid supplies so that several different fluids may separately flow within the lumens 38. According to this configuration, each lumen 38 may be connected to a separate fluid supply so that the total number of different fluids that may be delivered to the anatomy is equal to the number of lumens 38. Alternatively, the fluid lumens need not be fluidly independent. For example, the membrane 26 may not be secured to the support 22 along the entire length of the support 22, thus permitting fluid 36 to migrate between lumens 38.

In operation, the catheter 20 delivers fluid directly to the area of the anatomy that is adjacent to the infusion section 32. The fluid 36 from the fluid source 34 is introduced into the axial lumens 38 at the proximal end of the catheter 20. The fluid 36 initially flows through the non-infusing section 28. When the fluid 36 first reaches the infusion section 32, it soaks into the porous membrane 26. As more fluid 36 enters the infusion section 32, it diffuses longitudinally within the walls of the membrane 26 until the entire membrane 26 and infusion section 32 are saturated with fluid. At this point the fluid 36 begins to pass through the membrane 26, thereby exiting the catheter 20 and entering the anatomy. Moreover, the fluid 36 advantageously passes through the entire surface area of the porous membrane 26 at a substantially uniform rate, due to the characteristics of the membrane 26. Thus, the

11

fluid is delivered at a substantially equal rate throughout a generally linear segment of the wound area of the anatomy. Furthermore, this advantage is obtained for both low and high pressure fluid delivery.

FIGS. 5 and 6 illustrate a catheter 50 according to an alternative embodiment of the present invention. According to this embodiment, the catheter 50 includes an elongated outer tube 52 and an inner elongated tubular porous membrane 54. The tubular membrane 54 is preferably concentrically enclosed within the outer tube 52. More preferably, the tube 52 tightly surrounds and supports the tubular membrane 54 so that a relatively tight fit is achieved between the inner dimensions of tube 52 and the outer dimensions of membrane 54. A plurality of fluid exit holes 56 are provided within the tube 52, preferably throughout the entire circumference thereof. The portion of tube 52 that includes the exit holes 56 defines the infusion section of catheter 50. The tubular membrane 54 need only be provided along the length of the infusion section, but could be longer. Optionally, axial exit holes may be provided within the distal tip 58 of the tube 52. Also, a guide wire and/or guide wire lumen may be provided to aid in the insertion of the catheter 50 into the anatomy, as will be understood by those skilled in the art.

The tube 52 may be formed from any of a variety of suitable materials, such as nylon, polyimide, Teflon and other materials known to those skilled in the art, giving due consideration to the goals of non-reactivity to anatomical systems, flexibility, light-weight, strength, smoothness, and safety. In a preferred configuration, the tube 52 is preferably a 20 gauge catheter tube, having inside and outside diameters of 0.019 inches and 0.031 inches, respectively. The exit holes 56 of tube 52 are preferably about 0.015 inches in diameter and provided at equally spaced axial positions along the tube 52. The holes 56 are preferably arranged so that every hole is angularly displaced about 120° relative, to the longitudinal axis of the tube 52, from the angular location of the previous hole. The axial separation between adjacent exit holes 56 is preferably within the range of about 0.125 to 0.25 inches, and more preferably about 3/16 inch. Also, the infusion section can have any desirable length. This configuration results in a thorough, uniform delivery of fluid throughout a generally linear segment of the wound area. Of course, the exit holes 56 may be provided in any of a variety of alternative arrangements.

The tubular porous membrane 54 is preferably a sponge-like or foam-like material or a hollow fiber. The tubular membrane 54 may have an average pore size, or pore diameter, less than 0.23 microns to filter bacteria. The pore diameter is preferably within the range of about 0.1 to 1.2 microns, more preferably within the range of about 0.3 to 1 micron, and even more preferably about 0.8 microns. The tubular membrane 54 may be formed from any of a variety of suitable materials, giving due consideration to the goals of non-reactivity to anatomical systems, maintaining flexibility, fitting within the size constraints of the tube 52, and having a porosity resulting in the substantially uniform dispensation of fluid through all of the exit holes 56 in tube 52. Some suitable materials for the membrane 54 are polyethylene, polysulfone, polyethersulfone, polypropylene, polyvinylidene difluoride, polycarbonate, nylon, or high density polyethylene. Preferable inside and outside diameters of the tubular membrane 54 are 0.010 inches and 0.018 inches, respectively. In the event that a guide wire 46 is provided, the guide wire may be a stainless steel wire about 0.005 inches in diameter. The tube 52 may be secured to the membrane 54 by epoxy or other means known to those skilled in the art. Alternatively, the membrane 54 may

12

contact the tube 52 with an interference fit and not use other materials to secure the membrane 54 in the tube 52.

In operation, the catheter 50 delivers fluid to the region of an anatomical system adjacent to the infusion section of catheter 50. As the fluid flows into the infusion section, it initially soaks into the tubular porous membrane 54. As more fluid enters the infusion section, the fluid diffuses longitudinally within the walls of the tubular member 54. Once the membrane 54 and the tubular space therein are saturated, the fluid passes through the membrane 54 and exits the catheter 50 by flowing through the exit holes 56 of the tube 52. Moreover, the fluid advantageously passes through the membrane substantially uniformly throughout the surface area of the membrane 54, resulting in a substantially uniform flow through substantially all of the exit holes 56. Thus, the fluid is delivered at a substantially equal rate throughout the wound area of the anatomy. Furthermore, this advantage is obtained for both low and high pressure fluid delivery.

FIG. 7 illustrates a catheter 70 according to another embodiment of the present invention. Catheter 70 includes a tube 72 having a plurality of exit holes 76 in side walls of the tube, and a tubular porous membrane 74 concentrically enclosing the tube 72. Catheter 70 operates in a similar manner to catheter 50 described above in connection with FIGS. 5 and 6. In use, fluid medication passes through the exit holes 76 and then begins to soak into the porous membrane 74. The fluid diffuses longitudinally within the walls of the membrane until the membrane is saturated. Thereafter, the fluid leaves the membrane walls and enters the anatomy. Advantageously, the fluid is dispensed to the anatomy at a substantially uniform rate throughout the surface area of the membrane 74. As in the previous embodiments, this advantage is obtained for both low and high pressure fluid delivery.

FIG. 8 illustrates a catheter 60 according to another embodiment of the present invention. Catheter 60 is better suited for relatively high flow rate delivery of fluid to a region within an anatomical system. Catheter 60 includes a tube 62 having a plurality of exit holes 64 of increasing size. In particular, the more distal exit holes are larger in diameter than the more proximal exit holes. The position of the exit holes 64 on the tube 62 defines the length of the infusion section of the catheter 60. The infusion section can have any desired length. The proximal end of catheter 60 is connected to a fluid supply, and a guide wire and/or guide wire lumen may also be provided for aiding in the insertion of catheter 60 into the anatomy.

As discussed above, for high or low pressure fluid delivery, exit holes nearer to the distal end of a catheter tube generally have increased flow resistance compared to exit holes nearer to the proximal end of the tube. Also, the fluid flowing through the more distal holes experiences a greater pressure drop. Consequently, there is generally a greater flow rate of fluid through the more proximal holes, resulting in non-uniform fluid delivery. In contrast, catheter 60 advantageously provides substantially uniform fluid delivery through substantially all of the exit holes 64, under relatively high flow rate conditions. This is because the larger size of the more distal holes compensates for their increased flow resistance and pressure drop. In other words, since the more distal holes are larger than the more proximal holes, there is a greater flow rate through the more distal holes than there would be if they were the same size as the more proximal holes. Advantageously, the holes 64 are provided in a gradually increasing size which results in substantially uniform fluid delivery. In addition, the exit holes 64 may be sized so that they combine to form a flow-restricting orifice, as described below in connection with the embodiment of FIG. 12.

As compared to prior art catheters, catheter **60** is advantageously simple and easy to manufacture. All that is required is to drill a plurality of exit holes **64** in the tube **62**. Furthermore, catheter **60** can sustain greater bending than prior art catheters while maintaining operability. In contrast to prior art catheters, such as the Wang catheter, if the tube **62** is bent somewhat, it will still deliver fluid relatively uniformly. This is because the tube **62** has a single lumen with a relatively large cross-section. When the tube **62** is somewhat bent, fluid flowing within the lumen is less likely to experience blockage and a consequent pressure change which might lead to non-uniform fluid dispensation.

The tube **62** of catheter **60** may be formed from any of a wide variety of materials, giving due consideration to the goals of non-reactivity to anatomical systems, flexibility, light-weight, strength, smoothness, and safety. Suitable materials include nylon, polyimide, Teflon, and other materials known to those skilled in the art. The infusion section can have any desired length but is preferably about 0.5 to 20 inches long, and more preferably about 10 inches long. The diameter of the exit holes **64** preferably ranges from about 0.0002 inches at the proximal end of the infusion section to about 0.01 inches at the distal end thereof. The largest, i.e., most distal, exit hole **64** is preferably about 0.25 inches from the distal end of the tube **62**. In the preferred configuration, the axial separation between adjacent holes **64** is within the range of about 0.125 to 0.25 inches, and more preferably about $\frac{3}{16}$ inch. Optionally, the holes **64** may be provided so that adjacent holes are angularly displaced by about 120° as in the embodiment of FIG. 5. Of course, if too many exit holes **64** are provided, the tube **62** may be undesirably weakened.

FIGS. 9, 10A, and 10B illustrate a catheter **80** according to another embodiment of the present invention. The catheter **80** comprises a tube **82**, a “weeping” tubular coil spring **84**, and a stop **86**. The proximal end of the spring **84** is attached to the distal end of the tube **82** so that the tube and spring each define a portion of a central lumen. A preferably dome-shaped stop **86** is attached to and closes the distal end of the spring **84**. The portion of the spring **84** that is distal to the tube **82** comprises the infusion section of the catheter **80**. In an unstretched state, shown in FIG. 10A, the spring **84** has adjacent coils in contact with one another so that fluid within the spring and below a threshold dispensation pressure is prevented from exiting the lumen by flowing radially between the coils. The spring **84** has the property of stretching longitudinally, as shown in FIG. 10B, when the fluid pressure is greater than or equal to the threshold dispensation pressure of the spring, thereby permitting the fluid to be dispensed from the lumen by “weeping,” i.e., leaking radially outward between the coils. Alternatively, the spring may stretch radially without elongating to permit fluid to weep through the coils of the spring. Further, the spring may stretch both longitudinally and radially to permit weeping, as will be understood by those of skill in the art. Advantageously, the fluid between the coils of the spring is dispensed substantially uniformly throughout the length and circumference of the portion of the spring that is distal to the tube **82**, i.e., the infusion section. The catheter **80** can be used for both high or low flow rate fluid delivery.

In use, the catheter **80** is inserted into an anatomical region so that the spring **84** is in a region to which fluid medication is desired to be delivered. The spring is initially in an unstretched state, as shown in FIG. 10A. The fluid is introduced into a proximal end of the tube **82** of the catheter **80** and flows into and through the spring **84** until it reaches the stop **86**. As fluid is continually introduced into the proximal end of the tube **82**, the fluid builds inside of the spring **84**. When the spring **84** is filled with fluid, the fluid pressure rises more

quickly. The fluid imparts a force directed radially outward onto the spring coils. As the pressure builds, the outward force becomes larger. Once the fluid pressure rises to the threshold dispensation pressure, the outward force causes the spring coils to separate slightly so that the spring stretches longitudinally, as shown in FIG. 10B. Alternatively, the coils may separate radially, as discussed above. The fluid then flows through the separated coils to be dispensed from the catheter **80**. Moreover, the dispensation is advantageously uniform throughout the infusion section of the catheter **80**. As fluid is continually introduced into the tube **82**, the spring **84** remains stretched to continually dispense fluid to the desired region within the anatomy. If the fluid introduction temporarily ceases, the fluid pressure within the spring **84** may fall below the threshold dispensation pressure. If so, the spring will compress so that the coils are once again adjacent and the fluid is no longer dispensed.

Several spring types will achieve the purposes of this invention. Suitable spring types are 316L or 402L, which can be readily purchased. In a preferred configuration, the spring **84** has about 200 coils per inch along its length. In this configuration, the spring can advantageously sustain a high degree of bending without leaking fluid from within, and only a severe bend will cause adjacent coils to separate. Thus, the spring **84** may be flexed considerably within an anatomical region without causing fluid to leak and therefore be dispensed to only one region within the anatomy. The spring **84** can have any desired length to define the length of the infusion section of the catheter **80**. The spring may be formed from a variety of materials, giving due consideration to the goals of strength, flexibility, and safety. A preferred material is stainless steel. In the preferred configuration, the inside and outside diameters of the spring are about 0.02 inches and 0.03 inches, respectively, and the spring wire has a diameter of about 0.005 inches. The proximal end of the spring **84** is preferably concentrically enclosed within the distal end of the tube **82**. The spring can be glued to the inside wall of the tube **82** using, for example, a U.V. adhesive, a potting material, or other bonding materials. Alternatively, the spring can be soldered within the tube **82** or be fitted with a proximal plug and tightly plugged into the tube **82**.

The tube **82** and stop **86** can be formed from any of a variety of materials, giving due consideration to the goals of flexibility, light-weight, strength, smoothness, and safety. Suitable materials include nylon, polyimide, Teflon, and other materials known to those skilled in the art.

FIG. 11 illustrates a catheter **90** according to another embodiment of the present invention. The catheter **90** comprises a distally closed tube **92** and a “weeping” tubular coil spring **94** concentrically enclosed within the tube **92** so that a lumen is defined within the tube and spring. A plurality of exit holes **96** are provided along a length of the tube **92**, in the side wall thereof. The length of the tube **92** including such exit holes **96** defines an infusion section of the catheter **90**. The exit holes **96** are preferably provided throughout the walls of the infusion section. The infusion section can have any desired length. In the preferred configuration, the axial spacing between adjacent holes **96** is within the range of about 0.125 to 0.25 inches, and more preferably about $\frac{3}{16}$ inch. Adjacent holes **96** are preferably angularly spaced apart by about 120° . The spring **94** is preferably enclosed within the infusion section of the catheter and configured similarly to the spring **84** of the embodiment of FIGS. 9, 10A and 10B. The spring **94** is preferably longer than the infusion portion and positioned so that all of the exit holes **96** are adjacent to the spring **94**. In this configuration, the fluid is prevented from exiting the lumen without flowing between the spring coils. A

15

stop is preferably attached to the tube to close the distal end thereof. Alternatively, the tube **92** may be formed with a closed distal end. The catheter **90** can be used for high or low flow rate fluid delivery.

In use, the catheter **90** is inserted into an anatomical region so that the infusion section is in a region to which fluid medication is desired to be delivered. The fluid is introduced into a proximal end of the tube **92** of the catheter **90** and flows through the spring **94** until it reaches the closed distal end of the tube **92**. As fluid is continually introduced into the proximal end of the tube **92**, the fluid builds inside of the spring **94**. Eventually, the spring **94** becomes filled with fluid, the fluid pressure rises, and the fluid weeps through the spring coils as described above in connection with the embodiment of FIGS. **9**, **10A**, and **10B**. Moreover, the fluid flows through the spring coils substantially uniformly throughout the length and circumference of the spring **94**. The fluid then exits the tube **92** by flowing through the exit holes **96** of the infusion section. The exit holes are preferably equal in size so that the fluid flows at a substantially equal rate through the exit holes, advantageously resulting in a generally uniform distribution of fluid throughout a desired region of the anatomy. As fluid is continually introduced into the catheter **90**, the spring **94** remains stretched to continually dispense fluid from the catheter. If the fluid introduction ceases temporarily, the fluid pressure within the spring **94** may fall below the threshold dispensation pressure. If so, the spring may compress so that the coils are once again adjacent and the fluid is no longer dispensed.

In the preferred configuration, the spring **94** and tube **92** are in contact along the entire length of the spring, so that the fluid weeping through the spring is forced to flow through the holes **96** of the infusion section. Preferably, one end of the spring **94** is attached to the inside walls of the tube **92**, permitting the other end of the spring to be displaced as the spring stretches. The spring can be glued to the tube **92** with, for example, a U.V. adhesive, potting material, or other bonding materials. Alternatively, an end of the spring can be soldered onto the inner walls of the tube **92**. The tube **92** can be formed from any suitable material. The inside walls of the tube **92** are preferably smooth so that the spring can more freely stretch and compress.

FIG. **12** illustrates a catheter **100** according to another embodiment of the present invention. The catheter **100** comprises a distally closed tube **102** having a plurality of exit holes **104** in side walls of the tube **102**. The portion of the tube **102** having exit holes **104** defines an infusion section of the catheter **100**. The exit holes **104** are sized to have a combined area of opening that is smaller than the area of any other flow-restricting cross-section or orifice of the catheter. Thus, the exit holes **104** are the flow-restrictor of the catheter **100**. In use, the catheter advantageously dispenses fluid through substantially all of the exit holes **104**. A fluid introduced into a proximal end of the tube **102** flows through the tube until it reaches the closed distal end thereof. At this point, the fluid builds within the infusion portion of the catheter. The fluid is substantially prevented from flowing through the holes **104**, due to their small size. Eventually, the infusion portion of the catheter becomes filled with fluid. As fluid is continually introduced into the proximal end of the tube **102**, the fluid pressure begins to build. At some point the pressure becomes sufficiently high to force the fluid through the exit holes **104**. Moreover, the fluid flows through substantially all of the exit holes **104**.

In this preferred configuration, the exit holes **104** are all equal in size so that the fluid is dispensed at a substantially equal rate through substantially all of the holes. The holes **104**

16

are preferably laser drilled to achieve a very small hole diameter. A preferred diameter of the exit holes **104** is about 0.0002 inches, or about 5 microns. Numerous exit holes **104** may be provided within the tube **102**. The holes are advantageously provided throughout the circumference of the infusion portion of the catheter **100**, to more uniformly deliver the fluid throughout an anatomical region. A preferred axial spacing between adjacent holes **104** is within the range of about 0.125 to 0.25 inches, and more preferably about $\frac{3}{16}$ inch. The catheter **100** can be used for high or low flow rate fluid delivery. The tube **102** can be formed from any of a variety of materials known to those skilled in the art and discussed previously.

FIG. **13** illustrates a catheter **200** according to another embodiment of the present invention. Catheter **200** includes a distally closed tube **202** having a plurality of exit holes **204** therein along an infusion section of the catheter, as in the above-described embodiments. The holes **204** are desirably provided throughout the circumference of the tube **202**. Enclosed within the tube **202** is an elongated member **206** formed of a porous material. Preferably, the member **206** is generally cylindrical in shape, and solid. Preferably, the member **206** is positioned within the tube **204** so that an annular space **208** is formed between the outer surface of the member **206** and the inner surface of the tube **202**. Preferably, the member **206** extends from the distal end **210** of the tube **202** rearwardly to a point proximal of the infusion section of the catheter. Alternatively, the member **206** may extend along only a portion of the infusion section. The member **206** is preferably generally concentric with the tube **202**, but non-concentric designs will achieve the advantages of the invention. Preferably, the member **206** is manufactured of a flexible material to assist with the placement of the catheter **200** in the body of a patient.

In operation, fluid medication flowing in the tube **202** saturates the porous member **206** and flows into the annular region **208**. Once the member **206** is saturated, the fluid in the member **206** flows into the region **208** and out of the catheter **200** through the exit holes **204**. Advantageously, since the fluid pressure is uniform throughout the annular region **208**, the fluid flows substantially uniformly through all of the holes **204**. There are several advantages of the annular region **208**. One advantage is that it tends to optimize the uniformity of flow through the exit holes **204**. Also, the member **206** may be formed from a porous material that tends to expand when saturated with liquid. If so, the member **206** preferably expands into the annular region **208** without pressing against the tube **202**. This limits the possibility of high pressure regions at the interior surface of the tube **202**, which could cause uneven exit flow of the medication within the wound site. Alternatively, the member **206** may expand and come into contact with the tube **202**, and still accomplish the goals of the present invention.

The member **206** is formed of a porous material having an average pore size preferably within the range of 0.1-50 microns, and more preferably about 0.45 microns. The radial width **W** of the annular region **208** is preferably within the range of 0 to about 0.005 microns, and more preferably about 0.003 microns. The member **206** can be formed of any of a variety of materials, giving due consideration to the goals of porosity, flexibility, strength, and durability. A preferred material is Mentek.

The member **206** can be secured within the tube **202** by the use of an adhesive. In one embodiment, as shown in FIG. **13**, the adhesive is applied at the distal end of the member **206** to form a bond **212** with the interior surface of the distal end of the tube **202**. Preferably, adhesive is applied at or near the proximal end of the infusion section of the catheter **200**.

Additionally, the adhesive can be applied to the circumference of the member **206** at any longitudinal position thereof, forming a ring-shaped bond with the interior surface of the tube **202**. For example, in the embodiment of FIG. **13**, a ring-shaped bond **214** is provided just proximal of the infusion section of the catheter **200**. Other configurations are possible. For example, FIG. **14** shows an embodiment in which the adhesive is applied to the distal end of the member **206** to form a bond **216**, and also at generally the center of the infusion section to form a ring-shaped bond **218**. FIG. **15** shows an embodiment in which the adhesive is applied only to the distal end of the member **206** to form a bond **220**. FIG. **16** shows an embodiment in which the adhesive is applied only to the center of the infusion section to form a ring-shaped bond **222**. Those of ordinary skill in the art will understand from the teachings herein that the adhesive may be applied in any of a variety of configurations. Thus, for example, adhesive at the distal end of the catheter (i.e., **212**, **216**, and **220** in FIGS. **13**, **14**, and **15**, respectively) is not required.

In the current best mode of the invention, preferably two bonds are incorporated—one at the most proximal hole and one at the most distal hole of the catheter. Each bond is formed with an adhesive as described below.

The ring-shaped bond **214** can be formed by pouring the adhesive in liquid form through one of the exit holes **204** when the member **206** is in the tube **202**. The adhesive, having a generally high viscosity, tends to flow about the circumference of the member **206**, rather than into the body of the member. The adhesive thus forms a ring-shaped bond with the tube **202**, as will be understood by those of skill in the art. Also, the adhesive plugs the exit hole **204** through which it is poured. Any of a variety of different types of adhesives will be acceptable, a preferred adhesive being Loctite.

As mentioned above, the member **206** is preferably concentric with the tube **202**. FIG. **17** shows a cross-section of a catheter **200** in which the member **206** is concentrically enclosed within the tube **202**. Alternatively, the member **206** may be positioned adjacent to the tube **202**, as shown in FIG. **18**. The configuration of FIG. **18** may be easier to manufacture than that of FIG. **17**, since the member **206** does not have to be centered within the tube **202**.

Those of ordinary skill in the art will understand from the teachings herein that the member **206** can be of any desired length and can extend along any desired length of the infusion section of the catheter **200**. For example, the member **206** does not have to extend to the distal end of the tube **202**. Further, the proximal end of the member **206** may be either distal or proximal to the proximal end of the infusion section.

When any of the catheters of the above embodiments is used, the catheter may initially have air inside of the catheter tube. For example, the catheter **200** shown in FIG. **13** may have air inside of the porous material of the member **206**. The introduction of liquid medication into the catheter forces the air to flow out of the exit holes. However, this may take several hours. If the catheter is inserted into a patient while air is inside, and liquid medication is introduced into the catheter, the patient's wound site may receive little or no medication until air is expelled from the catheter tube. Thus, it is preferred to run the liquid medication through the catheter prior to inserting the catheter into a patient, to ensure that the air is expelled from the catheter prior to use. Further, with reference to FIG. **19**, an air filter **224**, as known in the art, can be inserted into the catheter tubing proximal the infusion section **226** of the catheter **200**. The filter **224** prevents undesirable air from entering the infusion section **226** of the catheter **200**.

FIGS. **20** and **21** illustrate catheter tubes having elongated exit holes or slots. These catheter tubes may be used in place

of the catheter tubes shown and described above. FIG. **20** shows a tube **230** having exit holes or slots **232** that are elongated in the longitudinal direction of the tube **230**. The slots **232** are preferably provided throughout the circumference of the tube **230**, along the infusion section of the catheter. Compared to smaller exit holes, the elongated slots **232** tend to increase the flow rate of fluid exiting the catheter, by reducing the flow impedance experienced by the fluid. Preferably, the slots **232** may be oriented longitudinally on the catheter body so as not to compromise the structural integrity of the catheter **200**, as will be easily understood by those of skill in the art.

FIG. **21** shows a tube **234** having exit holes or slots **236** whose lengths increase along the length of the tube in the distal direction. In the illustrated embodiment, the slots nearer to the proximal end of the infusion section of the tube **234** are shorter in length than the slots nearer to the distal end of the infusion section. As in the embodiment of FIG. **8**, the catheter tube **234** advantageously provides substantially uniform fluid delivery through substantially all of the exit slots **236**, under relatively high flow rate conditions. This is because the larger size of the more distal slots compensates for their increased flow resistance and pressure drop. In other words, since the more distal slots are larger than the more proximal slots, there is a greater flow rate through the more distal slots than there would be if they were the same size as the more proximal slots. Advantageously, the slots **236** are provided in a gradually increasing length, which results in substantially uniform fluid delivery. Further, the elongated slots result in generally higher exit flow rates, as in the embodiment of FIG. **20**.

With regard to all of the above embodiments of catheters, an independent guide wire lumen may be provided within or adjacent to the lumen(s) disclosed, as will be understood by those skilled in the art.

The catheters of the present invention can be used in various medical applications. With reference to FIG. **22**, in one exemplary application a catheter **20** (reference numeral **20** is used to identify the catheter, but any of the above-described catheters can be used) is inserted into a blood clot **240** inside of a vein or artery **242**. Preferably, the infusion section of the catheter is within the blood clot **240**. Liquid medication is preferably introduced into the proximal end of the catheter tube. Advantageously, the medication exits the catheter **20**, preferably at a substantially uniform rate throughout the infusion section to dissolve the clot **240**.

FIGS. **23** and **24** illustrate another preferred embodiment of a catheter **250**. As shown in FIG. **23**, preferably, the catheter **250** is comprised of an elongated catheter body, or tube **254**, and an outer elongated tubular porous membrane, or tubular sheath **252**. The elongated tube **254** has a central lumen **268**, which is in fluid communication with a fluid supply, preferably similar to the fluid supply **34** of FIG. **1**.

Preferably, the tubular membrane **252** covers a length **255** of the elongated tube **254** and is positioned a distance **253** proximal of a distal end **262** of the elongated tube **254**. In one embodiment, the length **255** is about 2.40 inches and the distance **253** is about 0.10 inches. In another embodiment, the length **255** is about 2.50 inches. In still another embodiment, the length **255** is about 5.00 inches. In other embodiments, the length **255** and the distance **253** may be varied so that the catheter **250** generally conforms to the particular anatomy contemplated.

As shown in FIG. **23A**, desirably the tubular membrane **252** encloses a portion of the elongated tube **254** such that an annular, interstitial space **270** is created between an exterior surface of the tube **254** and an interior surface of the tubular

membrane **252**. In a preferred embodiment, the tube **254** is substantially concentric with the tubular membrane **252**. In a preferred arrangement, the space **270** has a radial dimension of less than about 0.007 inches. In another arrangement, the space **270** may have a radial dimension of between about 0.002 and 0.007 inches. However, in some arrangements, the space **270** may be minimal, or the inner surface of tubular membrane **252** may be in contact with the outer surface of the tube **254**.

A plurality of fluid exit holes **266** are provided within the portion of the tube **254** enclosed within the tubular membrane **252**. Preferably, the exit holes **266** are positioned throughout the entire circumference of the enclosed portion of the tube **254**. The portion of tube **254** that includes the exit holes **266** defines an infusion section of catheter **250**. Desirably the tubular membrane **252** is only provided along the length **255** of the infusion section. However, in an alternative arrangement, the tubular membrane could be longer than the infusion section. Also, in other embodiments, a guide wire and/or guide wire lumen may be provided to aid in the insertion of the catheter **250** into the anatomy, as will be understood by those skilled in the art.

The tube **254** may be formed from any of a variety of suitable materials, such as nylon, polyimide, ptfе and other materials known to those skilled in the art, giving due consideration to the goals of non-reactivity to anatomical systems, flexibility, lightweight, strength, smoothness, and safety. In a preferred configuration, the tube **254** is preferably a 20 gauge catheter tube, having inside and outside diameters of about 0.019 inches and about 0.031 inches, respectively.

The exit holes **266** of tube **254** are preferably about 0.015 inches in diameter and provided at equally spaced axial positions along the infusion section of the tube **254**. The holes **266** preferably are arranged so that every hole is angularly displaced about 120 degrees relative to the longitudinal axis of the tube **254**, from the angular location of the previous hole. The axial separation between adjacent exit holes **266** is preferably within the range of about 0.125 to 0.25 inches, and more preferably about $\frac{3}{16}$ inch. Of course, the exit holes **266** may be provided in any of a variety of alternative arrangements. Furthermore, the infusion section of the tube **254** may have any desirable length. However, preferably the infusion section remains enclosed within the tubular membrane **252** as discussed above. The embodiment illustrated in FIGS. **23** and **24** provides a thorough, uniform delivery of fluid throughout a generally linear segment of the wound area.

The tubular membrane **252** preferably is comprised of a highly porous material. In another embodiment, the tubular membrane **252** may be made of a sponge-like or foam-like material, or a hollow fiber. The tubular membrane **252** may have an average pore size, or pore diameter, of less than about 0.23 microns so as to filter bacteria. The pore diameter preferably is within the range of about 0.1 microns to about 0.5 microns, and more preferably within the range of about 0.2 to 0.45 microns. The tubular membrane **252** may be formed from any of a variety of suitable materials, giving due consideration to the goals of non-reactivity to anatomical systems, maintaining flexibility, fitting within the size constraints of the tubular membrane **252**, and having a porosity resulting in the substantially uniform dispensation of fluid through all of the pores in the tubular membrane **252**. Some suitable materials for the membrane **252** are polyethylene, polysulfone, polyethersulfone, polypropylene, polyvinylidene difluoride, polycarbonate, nylon, high density polyethylene or polytetrafluoroethylene. Preferably, the tubular

membrane **252** is a 19 gauge tube, having inside and outside diameters of about 0.038 inches and about 0.042 inches to 0.045 inches, respectively.

As shown in FIG. **24**, preferably, the tubular membrane **252** is secured to the tube **254** by distal and proximal tubular segments, or collars **264**, **265**. Preferably, the tubular segments **264**, **265** comprise shrink tubes that are affixed to the tube **254** and the ends of the tubular membrane **252**. The tubes **264**, **265** may also utilize an adhesive, such as Loctite, epoxy or other means known to those skilled in the art to assist in securing the tubular membrane **252** to the tube **254**. Alternatively, other suitable methods may be used to secure the membrane **252** to the tube **254**. For example, the membrane **252** may be secured to the tube **254** by thermal or chemical bonding, without the use of the tubular segments **264**, **265**.

In operation, the catheter **250** delivers fluid to the region of an anatomical system generally adjacent the tubular membrane **252** of the catheter **250**. As the fluid flows through the central lumen **268** into the infusion section, it initially flows through the exit holes **266** and into the space **270**. Fluid in the space **270** then soaks into the tubular porous membrane **252**. Once the walls of the tubular membrane **252** are saturated, the fluid passes through the tubular membrane **252** and exits the catheter **250**. Moreover, the fluid advantageously passes through the membrane substantially uniformly throughout the surface area of the tubular membrane **252**, resulting in a substantially uniform fluid output along the length **255** of the tubular membrane **252**. Thus, the fluid is delivered at a substantially equal rate throughout the wound area of the anatomy. Furthermore, this advantage is obtained for both low and high pressure fluid delivery.

FIGS. **25-27** illustrate another embodiment of an infusion catheter, referred to generally by the reference numeral **272**. Preferably, the catheter **272** comprises a non-porous tubular section, or tube **282**, which is connected to a distal bioabsorbable, porous tubular section **280**. The porous tubular section **280** has an interior lumen **281** and the non-porous tube **282** has an interior lumen **283**. The non-porous tube **282** defines a non-infusing section **274** of the catheter **272**, and preferably extends from a fluid supply **283** to a junction, or joint **278**, as shown in FIG. **25**. Similarly, the porous tubular section **280** defines an infusion section **276** of the catheter **272**, and preferably extends from the junction **278** to a distal end **284**. Preferably, the distal end **284** is defined by a tip **284a**, which defines a distal end of the lumen **281** within the porous tubular section **280**.

As shown in FIGS. **26-26A**, preferably the junction **278** is comprised of a distal end **285** of the tube **282** being inserted into a proximal end **287** of the lumen **281** within the tubular section **280**. Preferably, a suitable type of medical adhesive is applied between the overlapping surfaces of the tube **282** and the tubular section **280**, to hold the tubes **280**, **282** together. It is contemplated that the adhesive is of the biocompatible variety, such as medical "glue" that is used for closing wounds. As shown in FIG. **26A**, the proximal end **287** of the tubular section **280** overlaps the distal end **285** by a distance **286**. The distance **286** preferably is at least about 0.02 inches. More preferably, the distance **286** is at least about 0.03 inches, though in other embodiments the distance **286** may be varied to achieve a desirable level of joint strength. The, above-described overlap distances are preferred because they are capable of providing a secure joint between the tube **282** and the tubular section **280**. Preferably, however, the overlap distance does not exceed about 0.25 inches so that the overlap section does not inhibit the overall flexibility of the catheter **272**.

The tube **282** may be formed from any of a variety of suitable biocompatible materials, such as nylon, polyimide, ptfе and other materials known to those skilled in the art, giving due consideration to the goals of non-reactivity to anatomical systems, flexibility, light-weight, strength, smoothness, and safety. In one preferred embodiment, the tube **282** is comprised of a 20-gauge catheter tube, preferably having an outside diameter of no more than about 0.035 inches.

Preferably, the tubular section **280** has an outer diameter of about 0.042 inches and has an inner diameter sized so that the distal end **285** of the tube **282** fits snugly within the proximal end **287** of the lumen **281**, as shown in FIG. **26A**. In one preferred embodiment, the tubular section **280** is comprised of a highly porous material having an average pore size, or pore diameter, less than about 0.23 microns to filter bacteria. More preferably, the pore diameter is within the range of about 0.1 microns to about 0.5 microns, and still more preferably the pore diameter is within the range of about 0.2 to 0.45 microns.

As used herein, a porous material, or porous membrane, desirably refers to a material or member that is configured to permit a substance to pass therethrough with at least a small amount of resistance in the area through which the substance passes. A porous material or membrane, preferably, is comprised of a material which has an inherent property, or is manipulated to attain or enhance a property, that permits a liquid to pass therethrough in a torturous, or non-linear, route to slow the rate of passing of the substance through the material. Alternatively, the porous material or member may slow the diffusion rate of a substance by having a pore diameter sufficiently close in size to a size of a single molecule of the substance, or a unitary grouping of molecules, to inhibit the passing of a large number of molecules, or groups of molecules, through any one pore at one time. Typically, a porous material or membrane will achieve its desired regulation of the flow of a substance as a result of micro passages through the material itself, and not as a result of distinct passages created through the material or membrane by manipulative processes such as laser drilling, for example. The distinction between a porous material or membrane, as such, and a member having a plurality of manually-created holes therethrough will be readily appreciated by one of skill in the art.

In another embodiment, the tubular section **280** may be comprised of a non-porous material provided with a plurality of exit holes, as discussed herein. It is to be noted that these exit holes may be employed in the tubular section **280** in accordance with any of the embodiments discussed above. Moreover, the tubular section **280** can have any desirable length. In one embodiment, the tubular section **280** has a length of about 5 inches, and the tubular section **280** and the non-porous tube **282** have a combined length of about 20 inches. It will be appreciated that this configuration of the tubular section **280** provides uniform delivery of fluid along the length of the tubular section **280**, and thus is particularly useful for delivering fluids, such as medications to a length of wound areas, such as incisions and the like.

The material comprising the tubular section **280**, in addition to being porous, desirably is bio-absorbable, as mentioned briefly above. In one embodiment, the material comprising the tubular section **280** is dissolvable within the patient's body during a time period ranging between about 5 days to about 7 days from insertion. During this period of time, the patient's body processes the bio-absorbable material such that the strength of the junction **278** is reduced. This weakening of the junction **278** facilitates detachment of the non-porous tube **282** from the tubular section **280** and subse-

quent removal of the tube **282** from the wound site without disturbing the placement of the remaining portion (non-absorbed portion) of the porous tubular section **280** within the wound.

The catheter **272** is particularly suitable for use in conjunction with a pain management or intravenous system (i.e., an infusion pump). In operation, a physician or other practitioner positions the catheter **272** within a wound site on a patient's body. The tubular section **280** is inserted into the wound site to such an extent that, preferably, the entirety of the tubular section **280** and a portion of the distal end **285** of the tube **282** are enclosed within the patient's body. Preferably, between about 0.1 and 0.4 inches of the distal end of the non-bioabsorbable tube **282** is enclosed within the patient. More preferably, between about 0.1 and 0.5 inches of the distal end of the non-bioabsorbable tube **282** is enclosed within the patient. The tubular section **280** may be sutured to the surrounding tissue within the wound to "tack" the catheter **272** in position. This facilitates positioning the catheter **272** precisely within the wound site. Preferably, any sutures used to tack the catheter **272** into position are also constructed from a bio-absorbable material. As a result, both the tubular section **280** and the sutures will be absorbed by the body.

Once the catheter **272** is suitably attached to the patient, a proximal end of the tube **282** may be connected to an intravenous system or other fluid supply arrangement. The catheter **272** advantageously delivers fluid or other medication to the patient over the course of 5-7 days, or longer, depending on the nature of the particular wound site in question. During this time, the tubular section **280** is absorbed by the patient's body. Once the tubular section **280** is sufficiently absorbed, and the junction **278** is weakened, the non-porous tube **282** is pulled from the wound site. Because the junction **278** is weakened, pulling on the tube **282** detaches the distal end **285** of the tube **282** from the proximal end **287** of the tubular section **280**. Thus, when the tube **282** is removed, the tubular section **280** remains within the wound site and is absorbed by the patient's body. It will be appreciated that leaving the tubular section **280** within the wound site advantageously reduces the amount of trauma imparted to the surrounding tissue that would otherwise be caused by the use and removal of a conventional catheter or pain management system.

As will be easily understood by those of skill in the art, any of the catheter embodiments described herein may be used in a variety of applications including, but not limited to, peripheral nerve blocks, intrathecal infusions, epidural infusions, intravascular infusions, intraarterial infusions and intraarticular infusions, as well as in wound site pain management.

In addition, any of the catheters disclosed herein may be integral with a fluid line emanating from an infusion pump as opposed to being an independent catheter designed to be connected or secured to an infusion pump.

Although this invention has been disclosed in the context of certain preferred embodiments and examples, it will be understood by those skilled in the art that the present invention extends beyond the specifically disclosed embodiments to other alternative embodiments and/or uses of the invention and obvious modifications and equivalents thereof. Thus, it is intended that the scope of the present invention herein disclosed should not be limited by the particular disclosed embodiments described above, but should be determined only by a fair reading of the claims that follow.

What is claimed is:

1. A catheter for delivering a fluid to an anatomical region, comprising:
 - an elongate tubular catheter body having a uniform cross-sectional size and shape, said catheter body defining a

23

lumen, a distal end of said lumen being closed, a distal end of said catheter body having a plurality of openings extending through a side wall of said catheter body thereby defining an infusion section of said catheter that is limited to said distal end of said catheter body, said catheter body constructed from a first material;

a tubular sheath constructed from a second material different than said first material, wherein said second material is a porous material having an inherent property of permitting fluid flow through micro passages in said material, wherein said tubular sheath is a single layer positioned over said infusion section and having a first end permanently secured to said catheter body at a fixed location proximate a proximal end of said infusion section and a second end permanently secured to said catheter body at a fixed location proximate a distal end of said infusion section, said tubular sheath and said catheter body being configured such that fluid within said lumen exits said lumen through one of said plurality of openings, into an annular interstitial space between said catheter body and said tubular sheath having a radial dimension of about 0.002 inches to about 0.007 inches, and then passes only through said tubular sheath to exit said catheter;

wherein a pore size of said porous material is less than about 0.5 microns.

2. The catheter of claim 1, wherein said second end of said tubular sheath is bonded to said catheter body at a distance from a distal end of said catheter.

3. The catheter of claim 2, wherein said distance is approximately 0.1 inches.

4. The catheter of claim 1, wherein said tubular sheath has an outside diameter of less than or equal to about 0.045 inches.

5. The catheter of claim 1, wherein said tubular sheath has a length of between about 2 inches and 3 inches.

6. The catheter of claim 5, wherein said length of said tubular sheath is about 2.4 inches.

7. The catheter of claim 1, wherein said first end and said second end of said tubular sheath are thermally bonded to an outer surface of said catheter body.

8. The catheter of claim 1, wherein said first end and said second end of said tubular sheath are chemically bonded to an outer surface of said catheter body.

9. The catheter of claim 1, wherein each of said first end and said second end of said tubular sheath are bonded to an outer surface of said catheter body by a shrink tube member.

10. The catheter of claim 1, wherein said porous material comprises a hollow fiber material.

11. A catheter for delivering a fluid to an anatomical region, comprising:
 an elongate tubular catheter body having a side wall constructed from a first material, an outer surface of said side wall defining a substantially uniform first diameter, the catheter body comprising a lumen, a distal end of said catheter body permitting fluid to pass from within said lumen to external of said catheter body thereby defining an infusion section of said catheter that is limited to said distal end of said catheter body;

a tubular sheath constructed from a second material different than said first material, wherein said second material

24

is a porous material having an inherent property of permitting fluid flow through micro passages in said material, said tubular sheath having a single layer side wall, a first end and a second end, said tubular sheath being positioned over said infusion section such that said infusion section is between said first end and said second end and said tubular sheath does not extend substantially beyond said infusion section, an inner surface of said side wall of said tubular sheath defining a second diameter, said first and second diameters being configured to create an annular interstitial space between said tubular sheath and said catheter body having a radial dimension of about 0.002 inches to about 0.007, wherein said tubular sheath and said infusion section are substantially the same length;

a wherein said first end and said second end of said tubular sheath are secured to said outer surface of said catheter body to substantially seal said interstitial space such that fluid within said lumen must pass through said tubular sheath to exit said catheter;

wherein after passing through said catheter body, said fluid passes through said interstitial space and said tubular sheath without passing through any additional components of said catheter before exiting said catheter;

a first seal configured to create said substantial seal of said first end to said outer surface of said catheter body at a permanent fixed location proximate a proximal end of said infusion section; and

a second seal configured to create said substantial seal of said second end to said outer surface of said catheter body at a permanent fixed location proximate a distal end of said infusion section.

12. The catheter of claim 11, wherein said second end of said tubular sheath is secured to said catheter body at a distance from a distal end of said catheter.

13. The catheter of claim 12, wherein said distance is approximately 0.1 inches.

14. The catheter of claim 11, wherein said tubular sheath has an outside diameter of less than or equal to about 0.045 inches.

15. The catheter of claim 11, wherein said tubular sheath has a length of between about 2 inches and 3 inches.

16. The catheter of claim 15, wherein said length of said tubular sheath is about 2.4 inches.

17. The catheter of claim 11, wherein said first diameter is less than or equal to about 0.035 inches.

18. The catheter of claim 11, wherein said first end and said second end of said tubular sheath are thermally bonded to an outer surface of said catheter body.

19. The catheter of claim 11, wherein said first end and said second end of said tubular sheath are chemically bonded to an outer surface of said catheter body.

20. The catheter of claim 11, wherein each of said first end and said second end of said tubular sheath are bonded to an outer surface of said catheter body by a collar.

21. The catheter of claim 20, wherein said collar comprises a section of shrink tubing.

22. The catheter of claim 11, wherein said porous material comprises a hollow fiber material.

* * * * *