

US007503142B1

(12) **United States Patent**
Uhl

(10) **Patent No.:** **US 7,503,142 B1**
(45) **Date of Patent:** ***Mar. 17, 2009**

(54) **INSERTABLE PEST CATCHING DEVICE**

(76) Inventor: **Michael A. Uhl**, 5481 W. 2000 South,
Mendon, UT (US) 84325

(*) Notice: Subject to any disclaimer, the term of this
patent is extended or adjusted under 35
U.S.C. 154(b) by 0 days.

This patent is subject to a terminal dis-
claimer.

(21) Appl. No.: **11/688,204**

(22) Filed: **Mar. 19, 2007**

Related U.S. Application Data

(63) Continuation-in-part of application No. 11/111,626,
filed on Apr. 20, 2005, now Pat. No. 7,222,453.

(60) Provisional application No. 60/565,678, filed on Apr.
27, 2004.

(51) **Int. Cl.**
A01M 1/10 (2006.01)
A01M 1/12 (2006.01)
A01M 23/08 (2006.01)

(52) **U.S. Cl.** **43/122**; 43/65; 43/113;
222/81; 222/90; 141/331; 141/340

(58) **Field of Classification Search** 43/65,
43/66, 100, 102, 121, 122, 113; 222/80,
222/81, 89, 90, 460, 566; 30/2, 400, 407,
30/443; 141/331-334, 337, 338, 340-343
See application file for complete search history.

(56) **References Cited**

U.S. PATENT DOCUMENTS

149,918 A * 4/1874 Clough 43/65
209,666 A * 11/1878 Decou 141/340

218,175 A * 8/1879 Hollingshead 43/65
474,036 A * 5/1892 Wood 141/340
529,109 A * 11/1894 Burgess 43/121
549,305 A * 11/1895 Barnes 222/90
554,616 A * 2/1896 Cook 43/121

(Continued)

FOREIGN PATENT DOCUMENTS

CA 2067825 A * 10/1993

(Continued)

OTHER PUBLICATIONS

McNaughton, Inc., Wasp Trap, Unknown, One page internet adver-
tisement.*

(Continued)

Primary Examiner—Darren W Ark

(57) **ABSTRACT**

The insertable pest catching device is an invention that
because of its unique geometry and design provides for the
simple and cost effective catching of pests such as hornets and
yellow jackets. The device is principally intended for use in
combination with an empty plastic two-liter volume soda pop
bottle. In practice, an attractant such as a predetermined
amount of sugar water is placed into a capped plastic bottle
and the funnel shaped device is retentatively pressed into the
side of the bottle. The device in combination with the bottle
creates an attraction to pests. The pests are guided into the
bottle through the funnel and subsequently die within the
bottle. After a predetermined quantity of pests are trapped
within the bottle, the bottle, with the device still inserted may
be discarded as an entire assembly. Thus the disassembly,
mess, and washing common with prior art pest catching
devices are avoided. In certain embodiments, multiple
devices may be inserted into a single bottle.

25 Claims, 16 Drawing Sheets

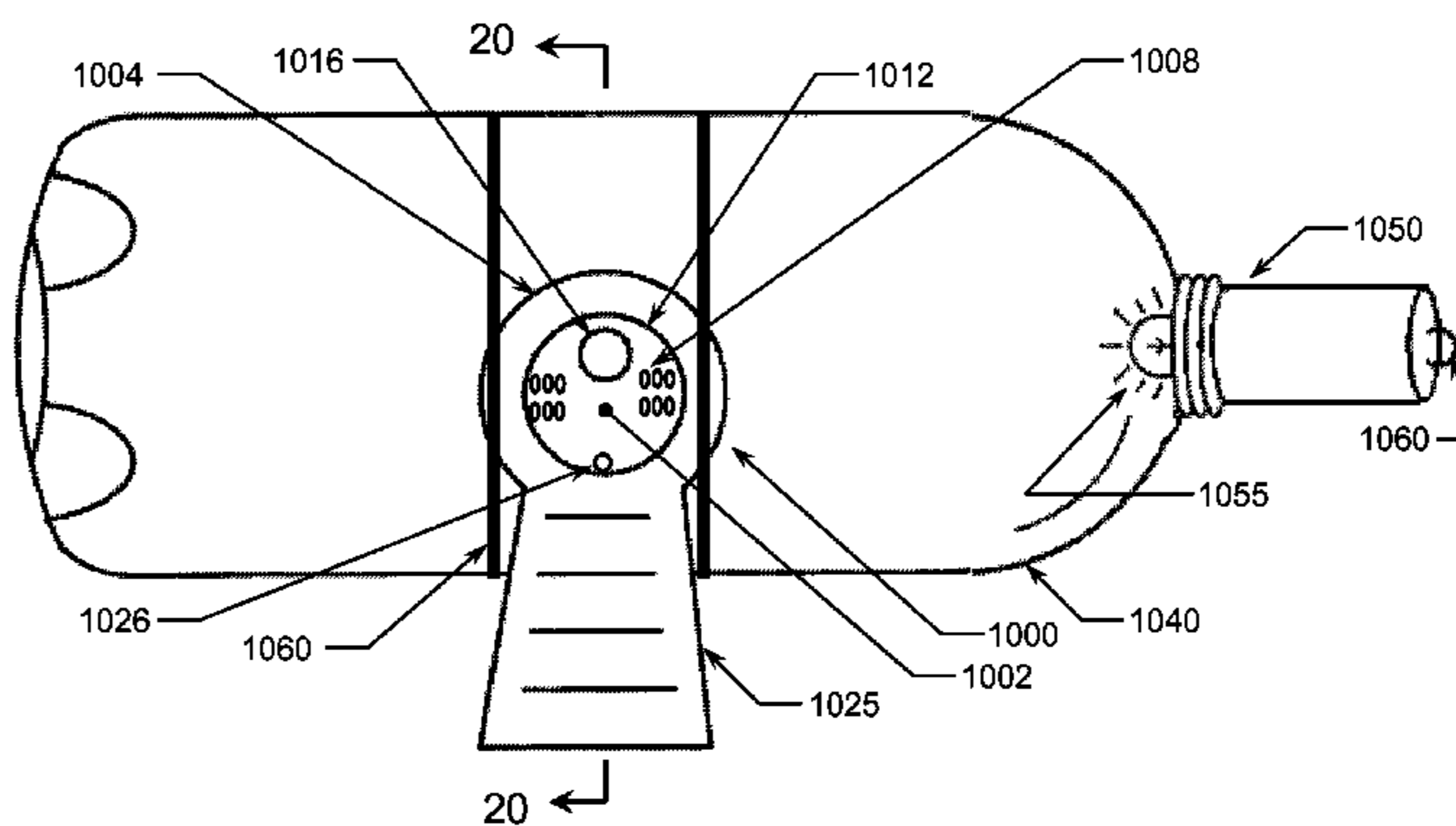
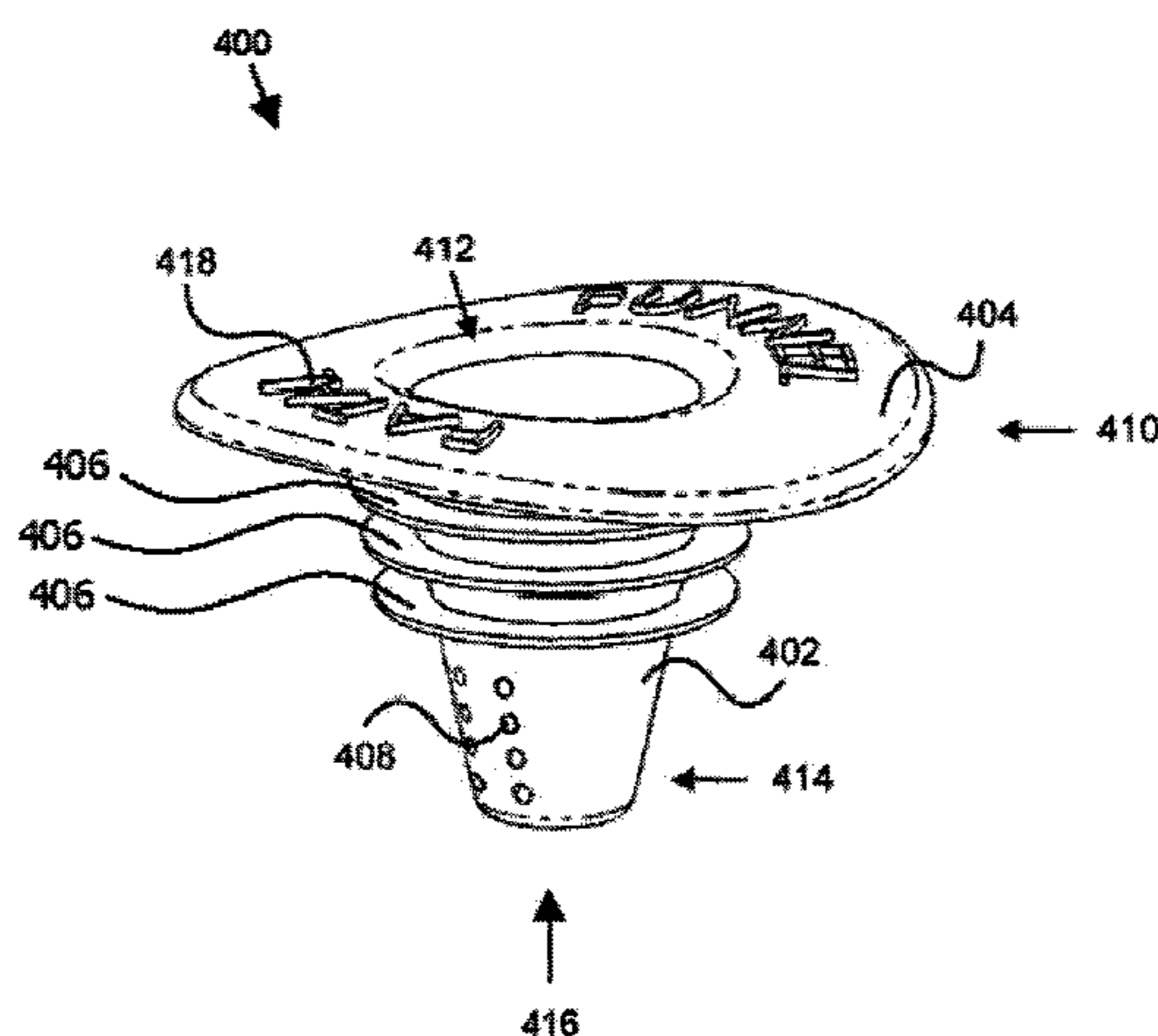

U.S. PATENT DOCUMENTS

590,032 A * 9/1897 Anderson 43/65
 720,990 A * 2/1903 Williams 43/113
 726,140 A * 4/1903 Campbell, Sr. 43/65
 766,083 A * 7/1904 Watts 222/90
 836,052 A * 11/1906 Pool 43/65
 858,157 A * 6/1907 Day 43/65
 869,556 A * 10/1907 Haas 43/113
 914,571 A * 3/1909 Heath et al. 43/65
 956,138 A * 4/1910 McAleer 43/65
 1,016,135 A * 1/1912 Foans 222/90
 1,139,717 A * 5/1915 Pipenhagen 43/121
 1,208,987 A * 12/1916 Lacht 43/121
 1,327,230 A * 1/1920 Fairbanks 43/121
 1,388,786 A * 8/1921 Albrecht et al. 43/65
 1,437,251 A * 11/1922 Kesling 43/113
 1,488,178 A * 3/1924 Floyd et al. 43/113
 1,499,222 A * 6/1924 Kiley 43/121
 1,505,651 A * 8/1924 Loeschen 43/113
 1,618,513 A * 2/1927 Coghill 43/66
 RE16,842 E * 1/1928 Hampton 141/332
 1,667,876 A * 5/1928 Steiner 43/113
 1,682,575 A * 8/1928 Leon et al. 43/107
 1,705,312 A * 3/1929 Rovano 141/340
 1,772,729 A * 8/1930 Pisani 43/107
 1,820,610 A * 8/1931 Eves 141/340
 1,867,252 A * 7/1932 Crigler 43/121
 1,911,076 A * 5/1933 Gandola 222/90
 1,946,509 A * 2/1934 Trammell 43/113
 1,979,337 A * 11/1934 Matthiessen, Jr. 222/90
 1,981,683 A * 11/1934 Wentzell 43/113
 2,000,193 A * 5/1935 Schroder 43/121
 2,007,449 A * 7/1935 Kernodle et al. 222/90
 2,052,445 A * 8/1936 Burns 222/90
 2,102,978 A * 12/1937 Slining 222/90
 2,118,366 A * 5/1938 Spielvogel 222/81
 2,158,502 A * 5/1939 Harrison 222/90
 2,162,623 A * 6/1939 Livingston 43/65
 2,361,321 A * 10/1944 Schleier 43/65
 2,421,589 A * 6/1947 Wiswell 222/89
 2,424,421 A * 7/1947 Temme 43/121
 2,569,833 A * 10/1951 Simpson, Sr. 43/65
 2,589,360 A * 3/1952 Ferguson 43/65
 2,606,327 A * 8/1952 Eckart et al. 141/331
 2,609,968 A * 9/1952 Ream 222/90
 2,666,553 A * 1/1954 Tammi 222/90
 2,671,576 A * 3/1954 Kuehn 222/90
 2,796,696 A * 6/1957 Kea 43/121
 2,898,698 A * 8/1959 Bair 43/113
 2,946,560 A * 7/1960 Ferm 141/331
 3,002,657 A * 10/1961 Liljemark 222/89
 3,196,577 A * 7/1965 Plunkett 43/113
 3,201,015 A * 8/1965 Wagaman 141/332
 3,201,893 A * 8/1965 Gesmar 43/113
 3,206,073 A * 9/1965 Scislowicz 222/80
 3,271,894 A * 9/1966 Manno et al. 43/65
 3,289,218 A * 12/1966 Mehilos 141/333
 3,320,692 A * 5/1967 Hellen 43/65
 3,343,724 A * 9/1967 Malpas 222/90
 3,460,715 A * 8/1969 Jones et al. 222/90
 3,771,578 A * 11/1973 Huff 141/340
 3,796,001 A * 3/1974 Jackson 43/113
 3,820,273 A * 6/1974 Novak 43/113
 3,821,861 A * 7/1974 Jalbert 43/65
 3,885,341 A * 5/1975 Kuchenbecker et al. 43/65
 3,902,652 A * 9/1975 Malcolm 222/81
 4,150,768 A * 4/1979 Maynard, Jr. 222/89
 4,208,828 A * 6/1980 Hall et al. 43/121
 4,212,129 A * 7/1980 Shumate 43/113
 4,218,842 A * 8/1980 Anderson 43/122
 4,476,647 A * 10/1984 Hall, Jr. 43/122
 4,531,245 A * 7/1985 Lowd et al. 141/337

4,551,941 A * 11/1985 Schneidmiller 43/121
 4,681,243 A * 7/1987 Takasugi 222/81
 4,706,410 A * 11/1987 Brieese 43/107
 4,794,724 A * 1/1989 Peters 43/122
 4,823,505 A * 4/1989 Jackson 43/124
 4,858,374 A * 8/1989 Clemons 43/122
 4,873,787 A * 10/1989 Schneidmiller 43/122
 4,881,662 A * 11/1989 Tallman 222/81
 4,899,485 A * 2/1990 Schneidmiller 43/122
 4,945,673 A * 8/1990 Lavelle 43/124
 5,058,312 A * 10/1991 Jackson 43/124
 5,081,788 A * 1/1992 Dowd et al. 43/113
 5,090,152 A * 2/1992 Ling 43/65
 5,095,185 A * 3/1992 Fuchs, Jr. 141/340
 5,209,010 A * 5/1993 Vickery 43/139
 5,226,254 A * 7/1993 MacMenigall 43/107
 5,228,233 A * 7/1993 Butler et al. 43/113
 5,274,949 A * 1/1994 Beaton 43/113
 5,301,456 A * 4/1994 Jobin et al. 43/113
 5,309,668 A * 5/1994 Barton 43/121
 5,309,669 A * 5/1994 Jackson 43/124
 D347,676 S 6/1994 VanWallendael D22/122
 5,323,556 A * 6/1994 Carle 43/113
 5,361,533 A * 11/1994 Pepper 43/124
 5,392,558 A * 2/1995 Blomquist 43/107
 5,400,923 A * 3/1995 Golias et al. 222/89
 5,406,743 A * 4/1995 McSherry et al. 43/122
 5,452,540 A 9/1995 Dowd et al. 43/107
 D371,418 S 7/1996 Rubel D22/122
 5,542,207 A * 8/1996 Morris, Sr. 43/132.1
 5,551,606 A * 9/1996 Rai et al. 222/460
 5,557,880 A * 9/1996 Schneidmiller 43/121
 5,568,790 A * 10/1996 Musgrave 43/65
 5,682,706 A 11/1997 Altenburg 43/122
 5,884,810 A * 3/1999 Vizcarra et al. 222/90
 6,095,433 A * 8/2000 Langdon 222/90
 6,112,452 A * 9/2000 Campbell 43/107
 6,134,826 A * 10/2000 Mah 43/113
 6,138,402 A * 10/2000 Wotton 43/122
 6,158,165 A * 12/2000 Wilson 43/66
 6,502,347 B1 * 1/2003 Carver, Sr. 43/113
 6,532,695 B1 * 3/2003 Alvarado 43/122
 6,546,667 B1 * 4/2003 Carter 43/107
 6,550,181 B1 * 4/2003 Ray 43/107
 6,609,329 B2 * 8/2003 McCallum 43/107
 6,626,327 B2 * 9/2003 Makino et al. 222/81
 6,637,149 B1 * 10/2003 Bauer 43/107
 6,739,363 B2 * 5/2004 Walter et al. 141/340
 6,754,988 B1 * 6/2004 Downey 43/107
 6,786,001 B1 * 9/2004 Piper et al. 43/113
 6,910,298 B2 * 6/2005 Schneidmiller 43/65
 6,925,749 B2 * 8/2005 Wong 43/121
 7,100,324 B2 * 9/2006 Lenker 43/107
 7,222,453 B2 * 5/2007 Uhl 43/122
 7,412,797 B1 * 8/2008 Hiscox 43/122
 2002/0011021 A1 1/2002 McCallum 43/122
 2002/0157301 A1 10/2002 Chrestman 43/122
 2003/0014904 A1 1/2003 Chrestman 43/122
 2003/0209575 A1 * 11/2003 Bremner et al. 222/566
 2005/0198892 A1 * 9/2005 Lin 43/66
 2006/0137240 A1 * 6/2006 Dismore 43/65

FOREIGN PATENT DOCUMENTS

DE 2901832 A1 * 7/1980
 FR 2298947 A * 10/1976
 FR 2386257 A * 12/1978
 GB 2052942 A * 2/1981
 GB 2283896 A * 5/1995
 GB 2396092 A * 6/2004
 JP 2001-103900 A * 4/2001
 JP 2001-169709 A * 6/2001
 JP 2001-269104 A * 10/2001

US 7,503,142 B1

Page 3

JP 2004-73144 A * 3/2004
JP 2004-97018 A * 4/2004
JP 2005-117970 A * 5/2005
JP 2005-143312 A * 6/2005
JP 2007-60928 A * 3/2007
KR 2003082677 A * 10/2003
KR 2004092310 A * 11/2004
WO WO-96/08964 A1 * 3/1996

WO WO-01/64032 A1 * 9/2001

OTHER PUBLICATIONS

Farnam Horse, Inc., Milk Jugg Trap, Unknown, One page internet advertisement.*

* cited by examiner

100

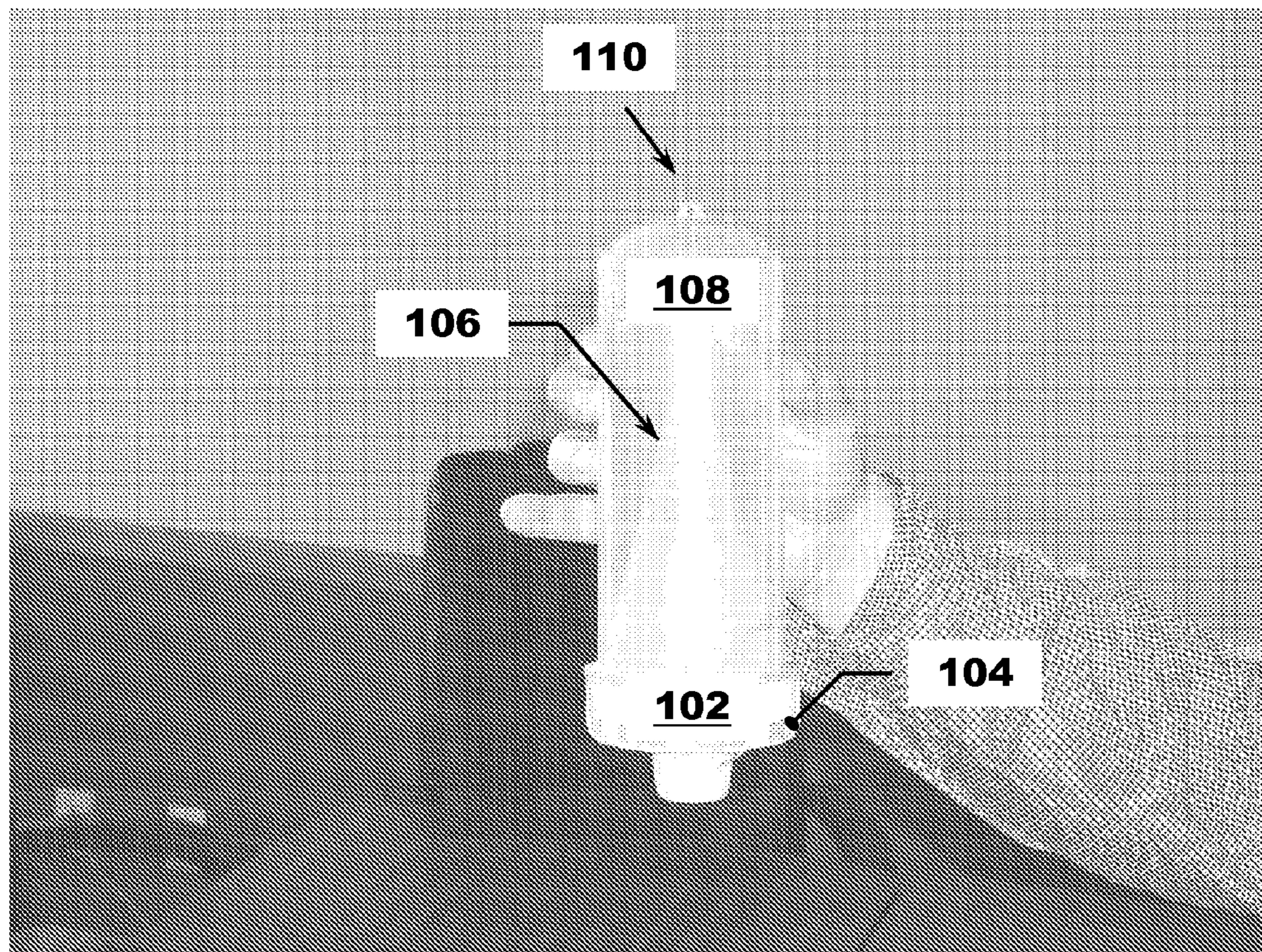

(Prior Art)
Fig. 1

200



(Prior Art)

Fig. 2

300

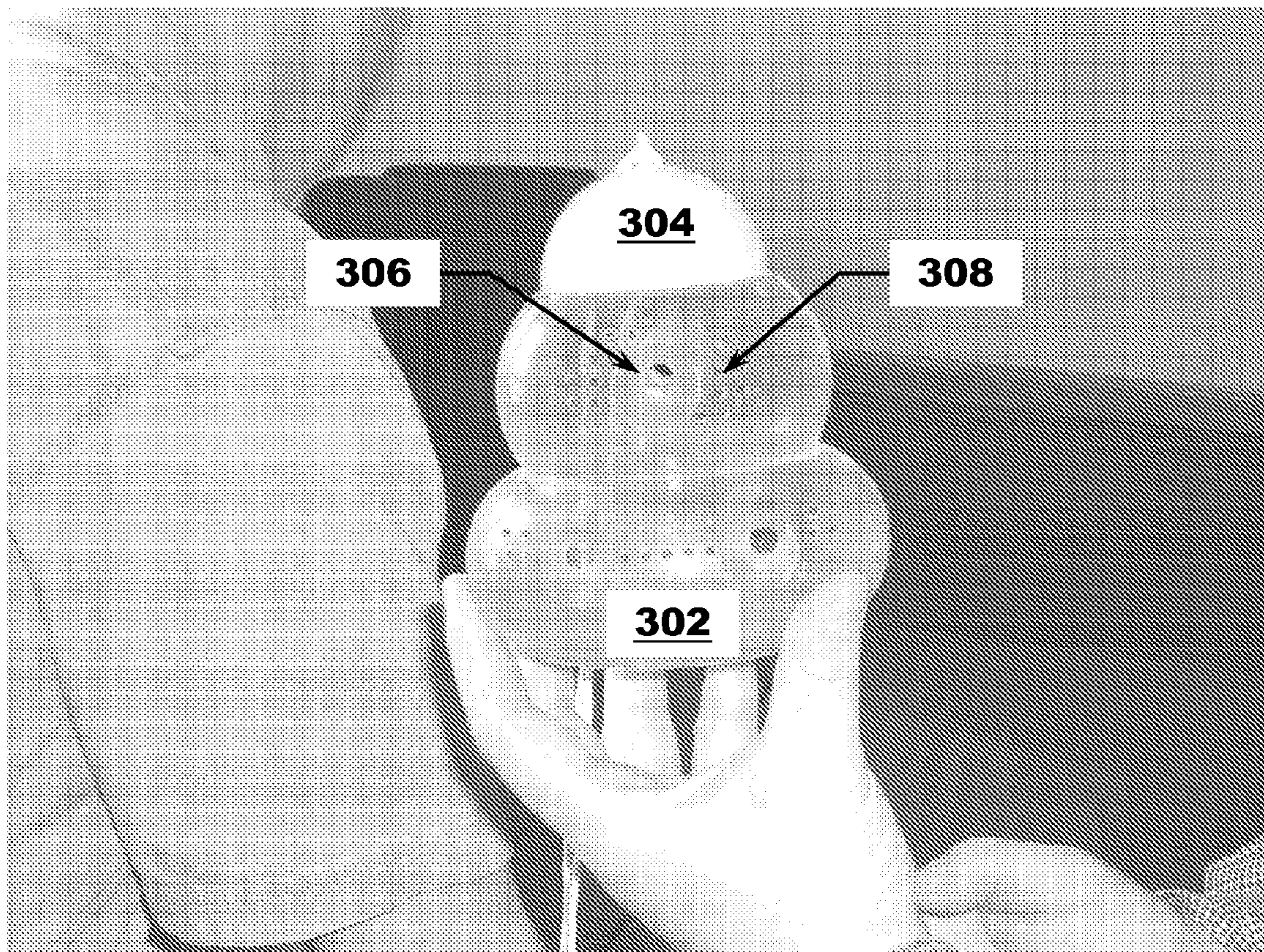

(Prior Art)

Fig. 3

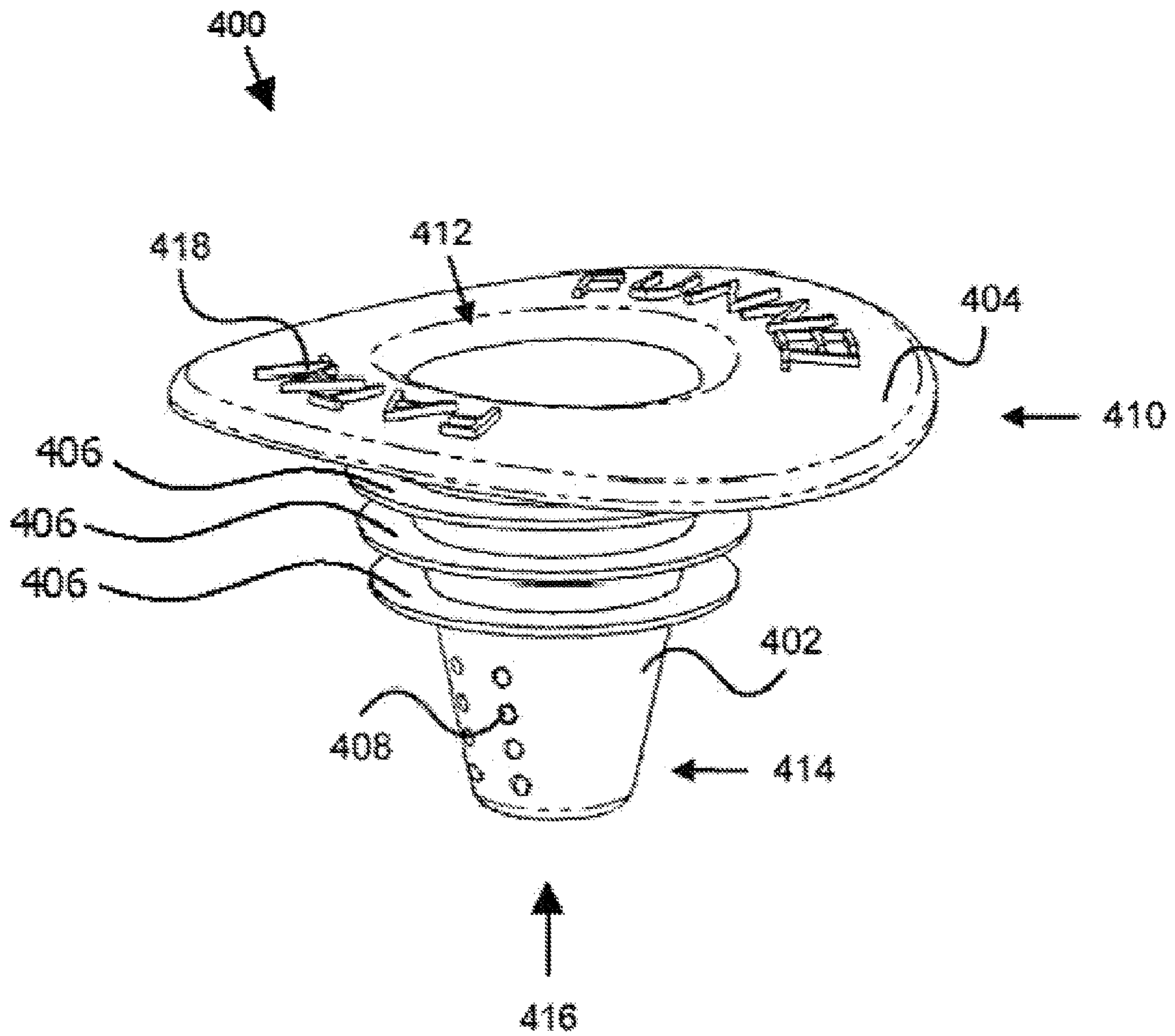

Fig. 4

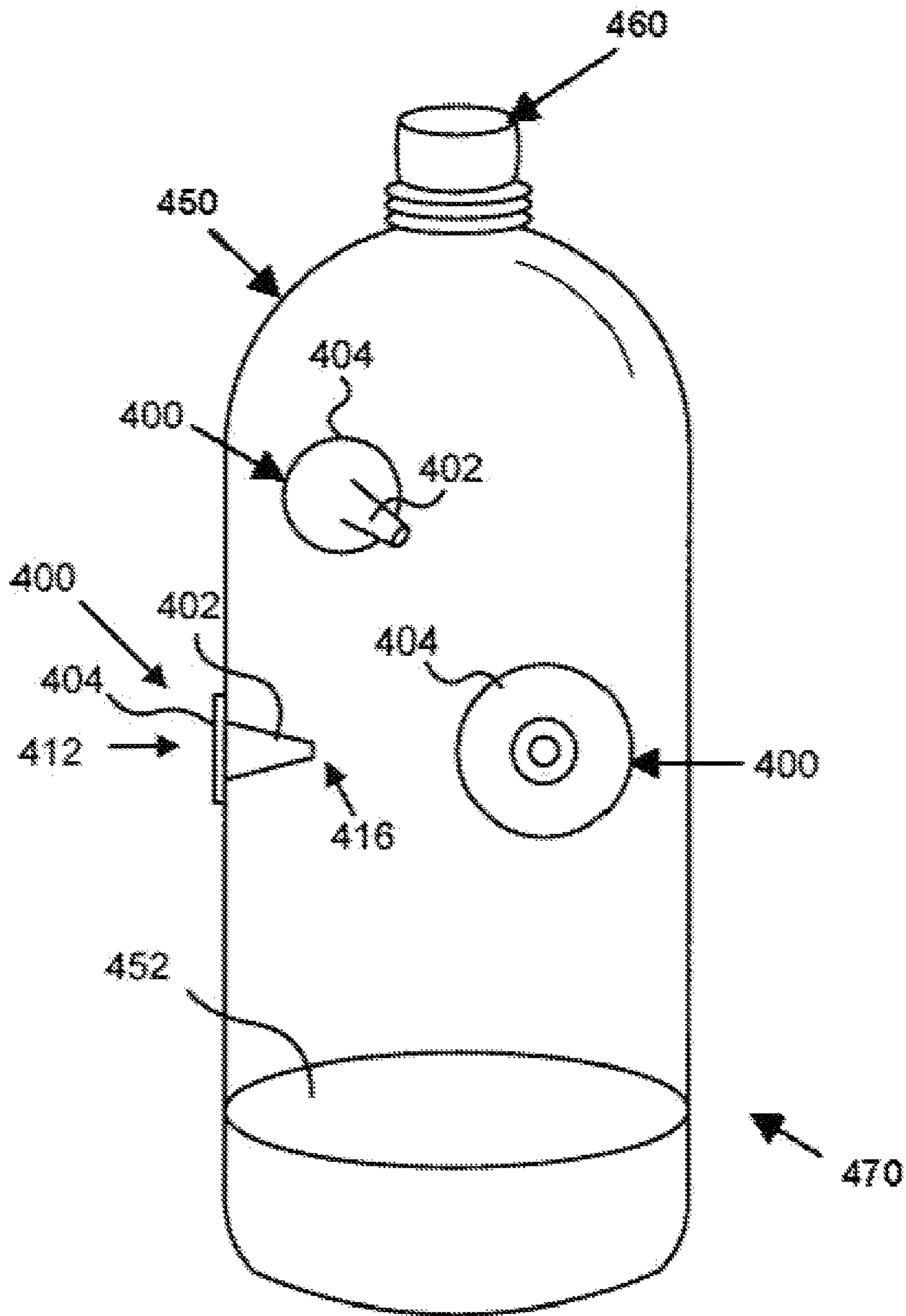

Fig. 5

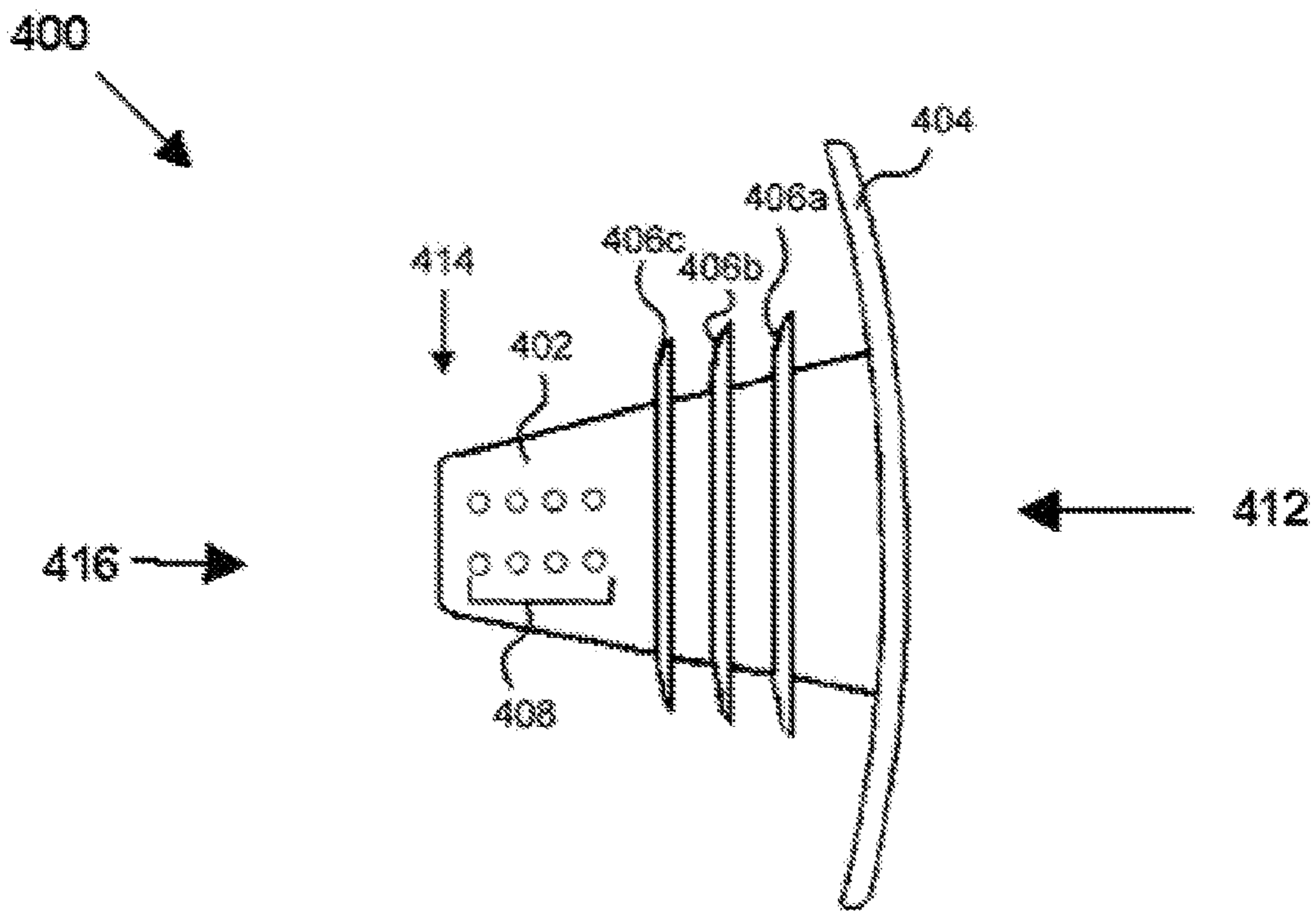

Fig 6

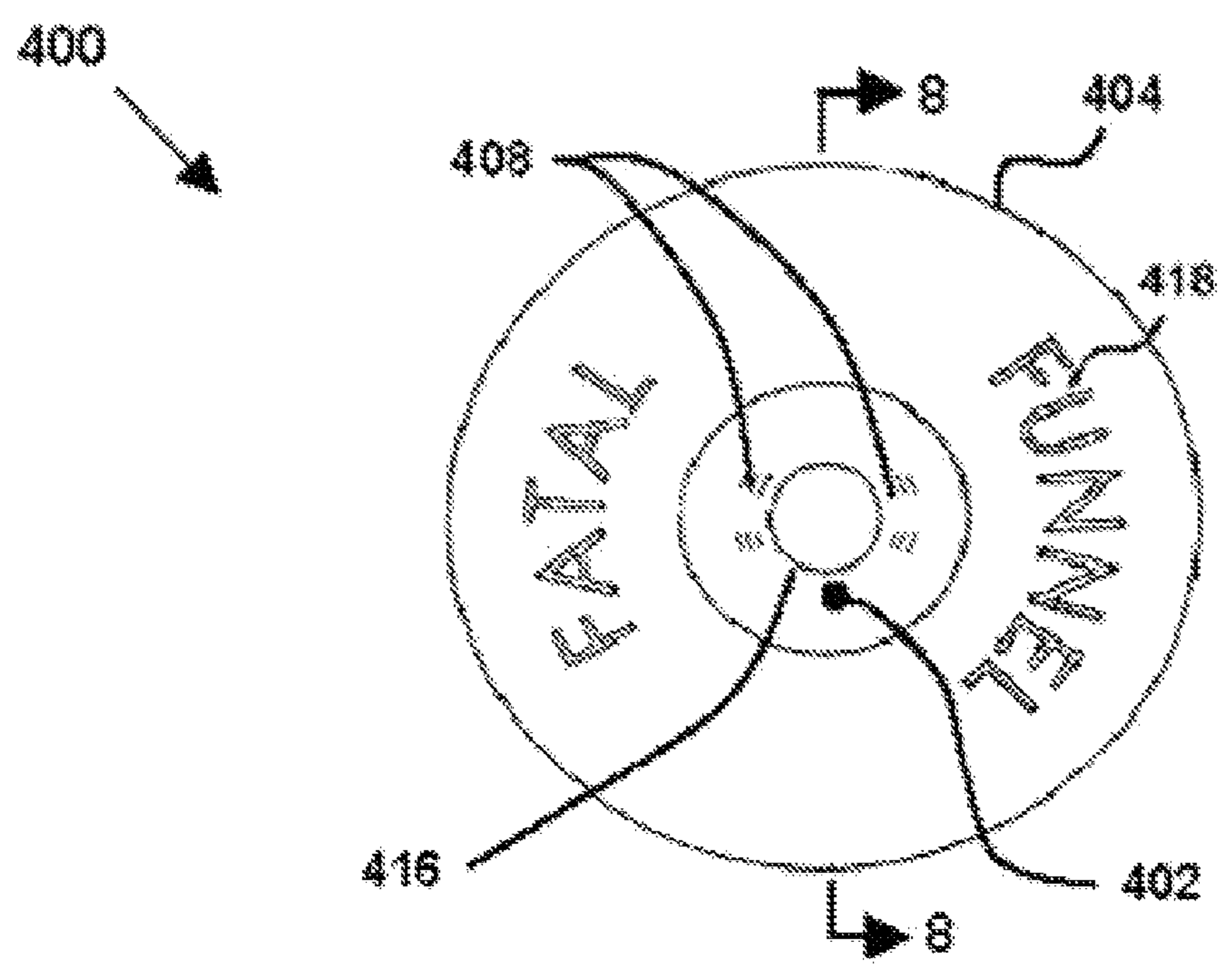

Fig. 7

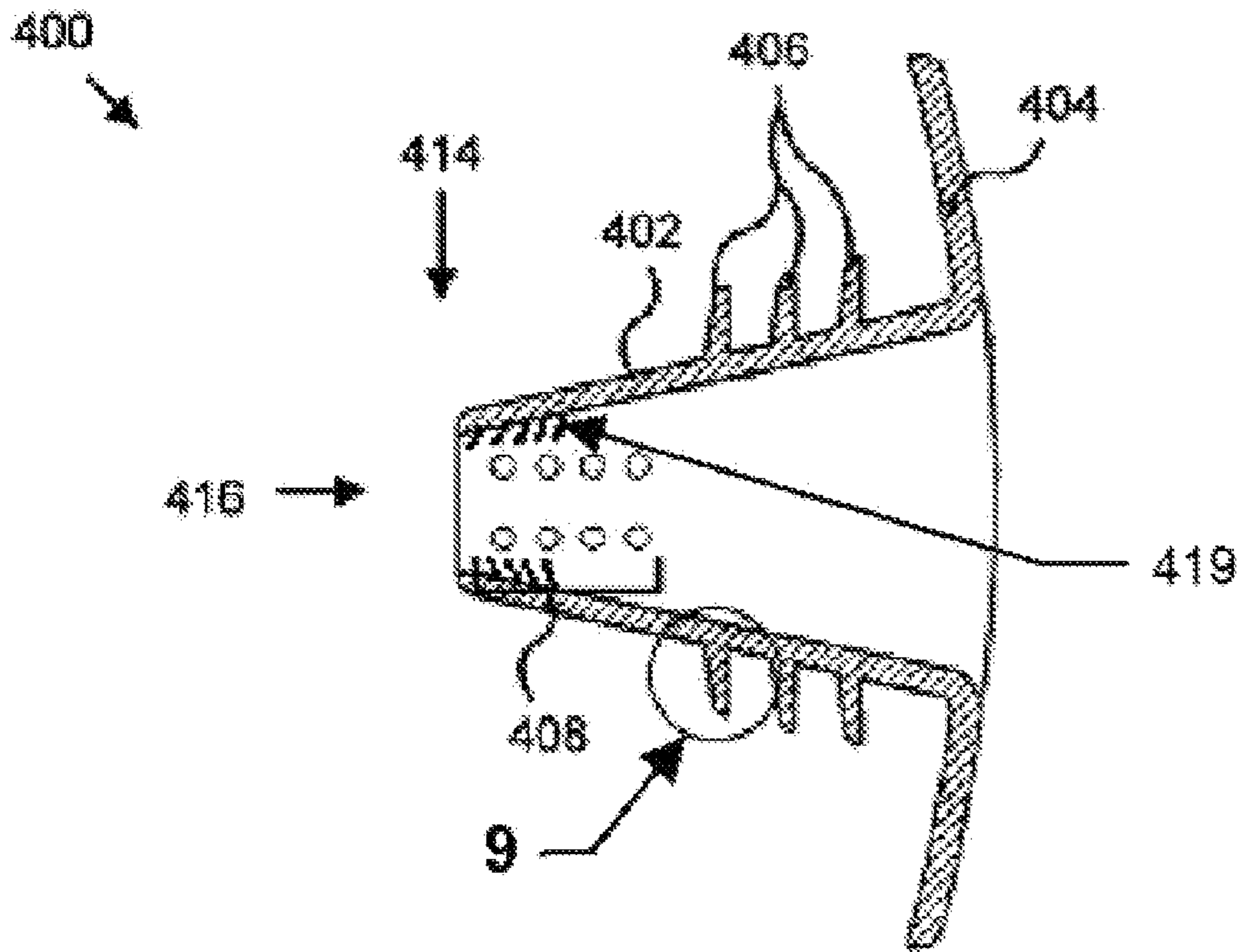

Fig 8

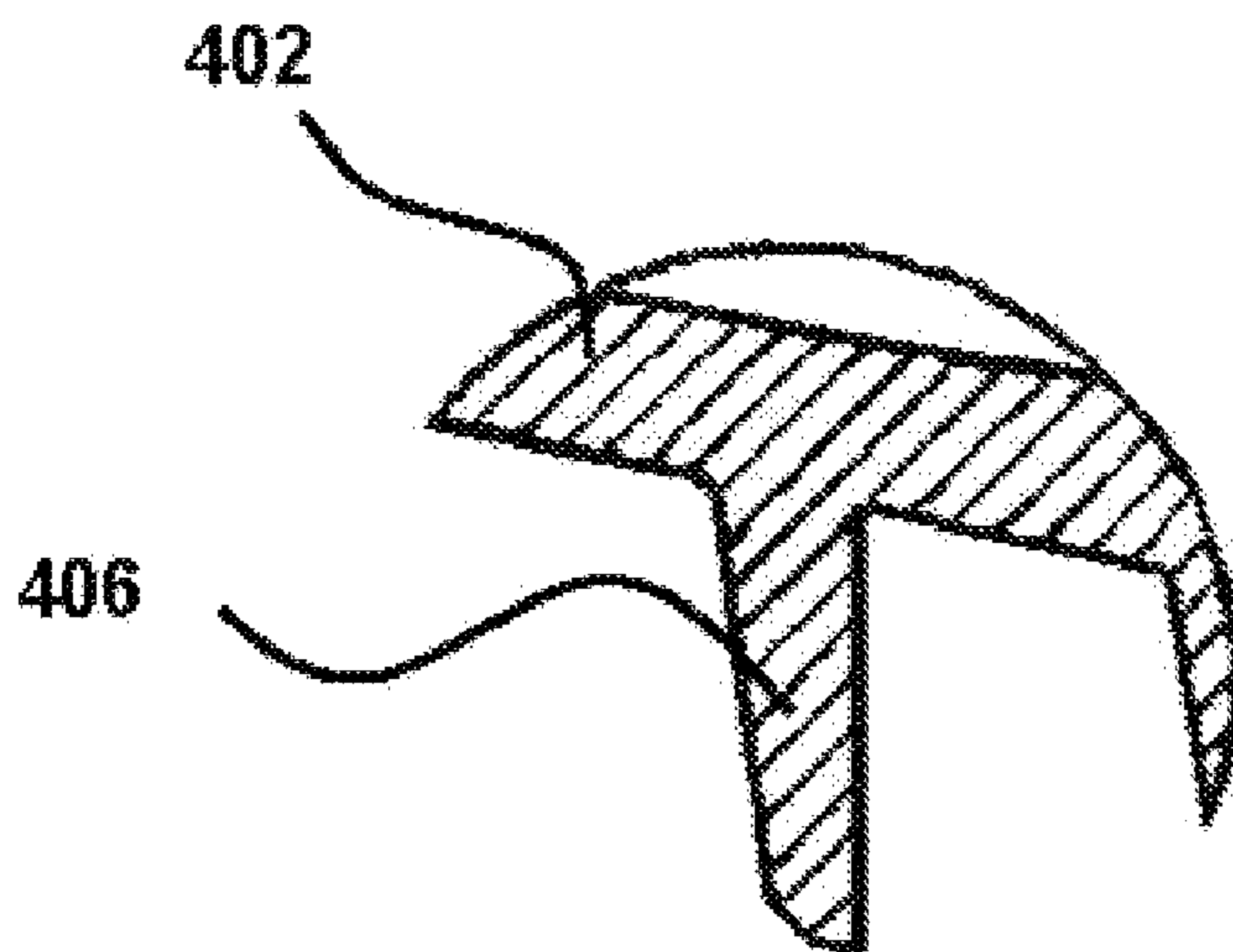

Fig 9

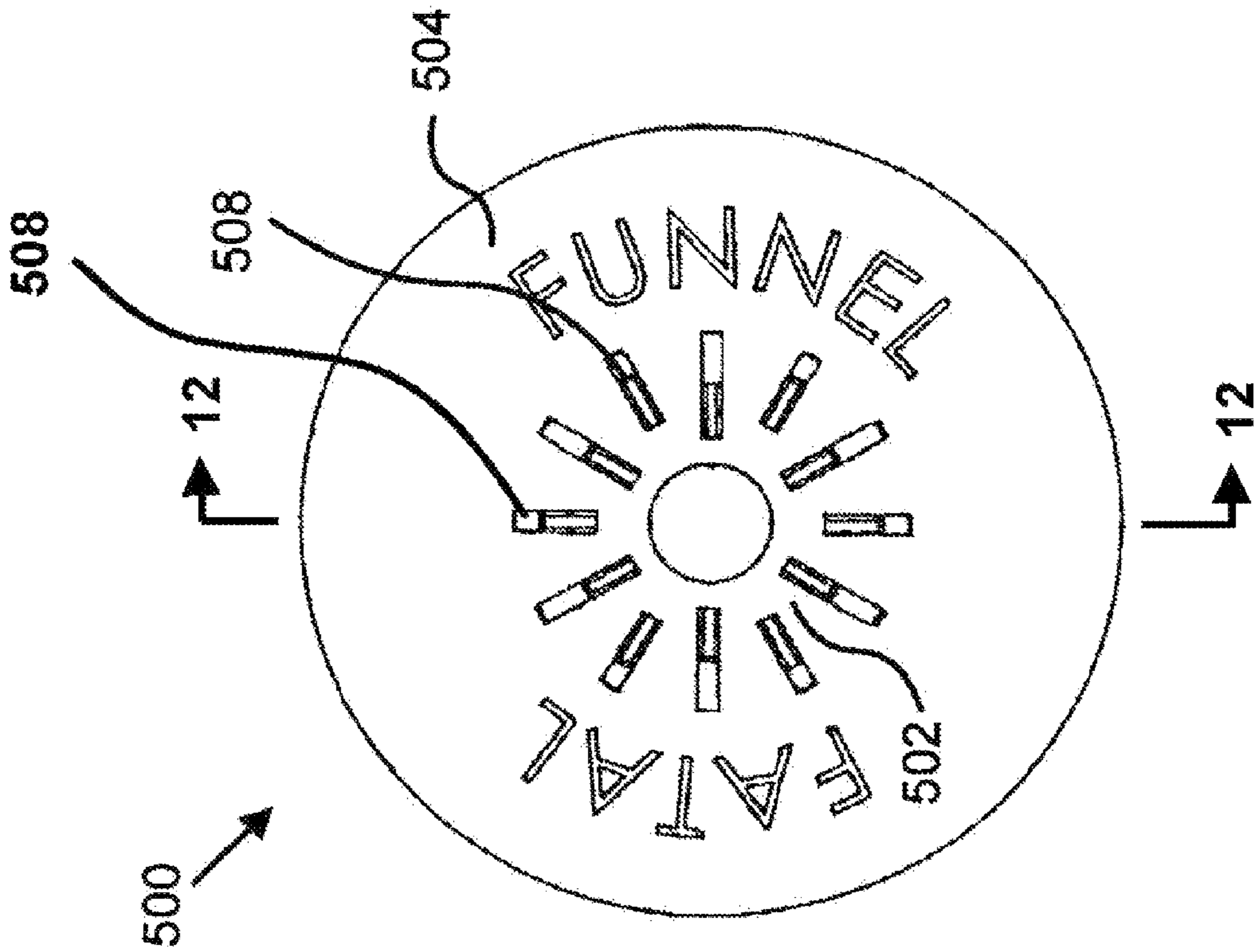

Fig 11

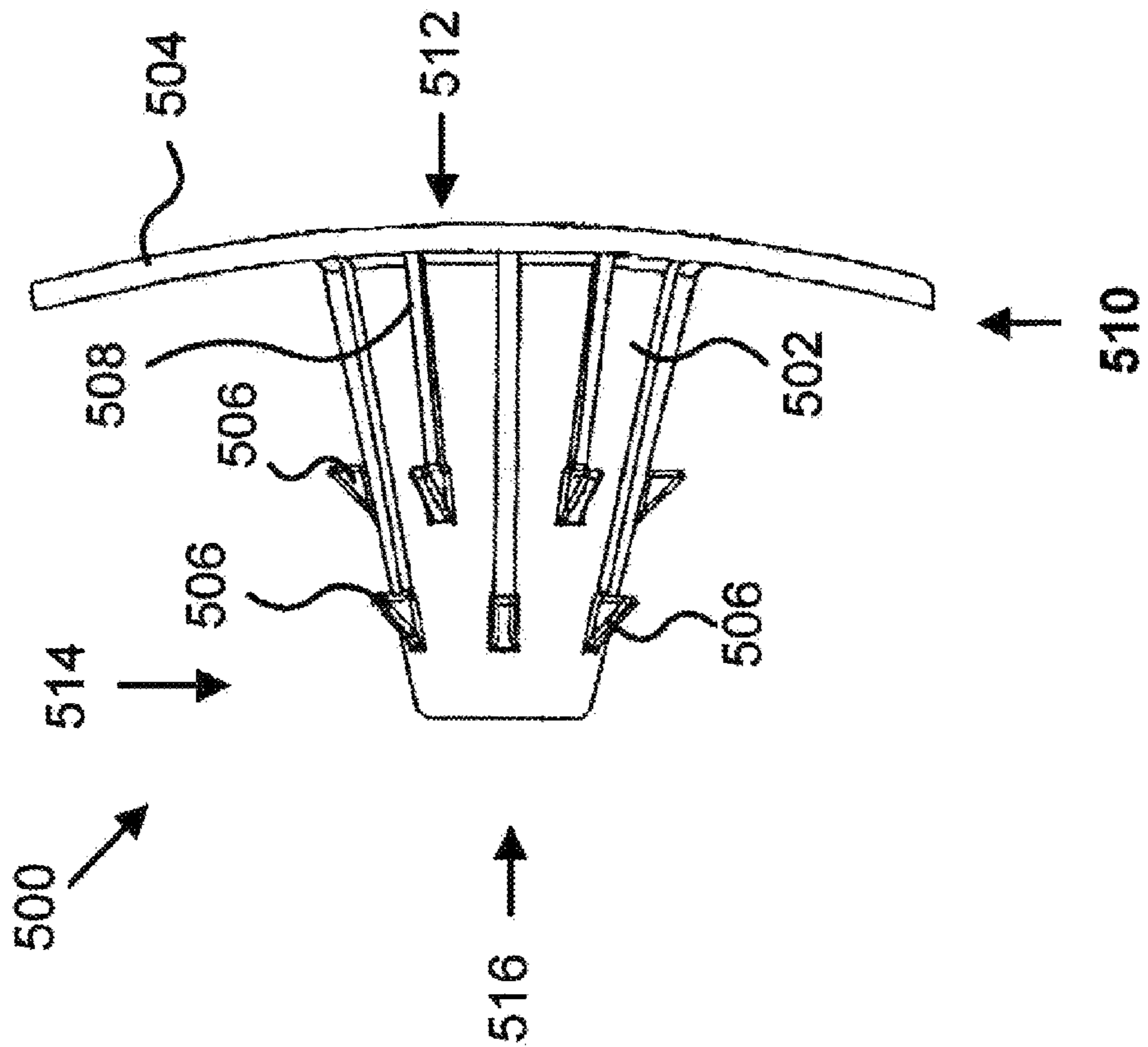

Fig 10

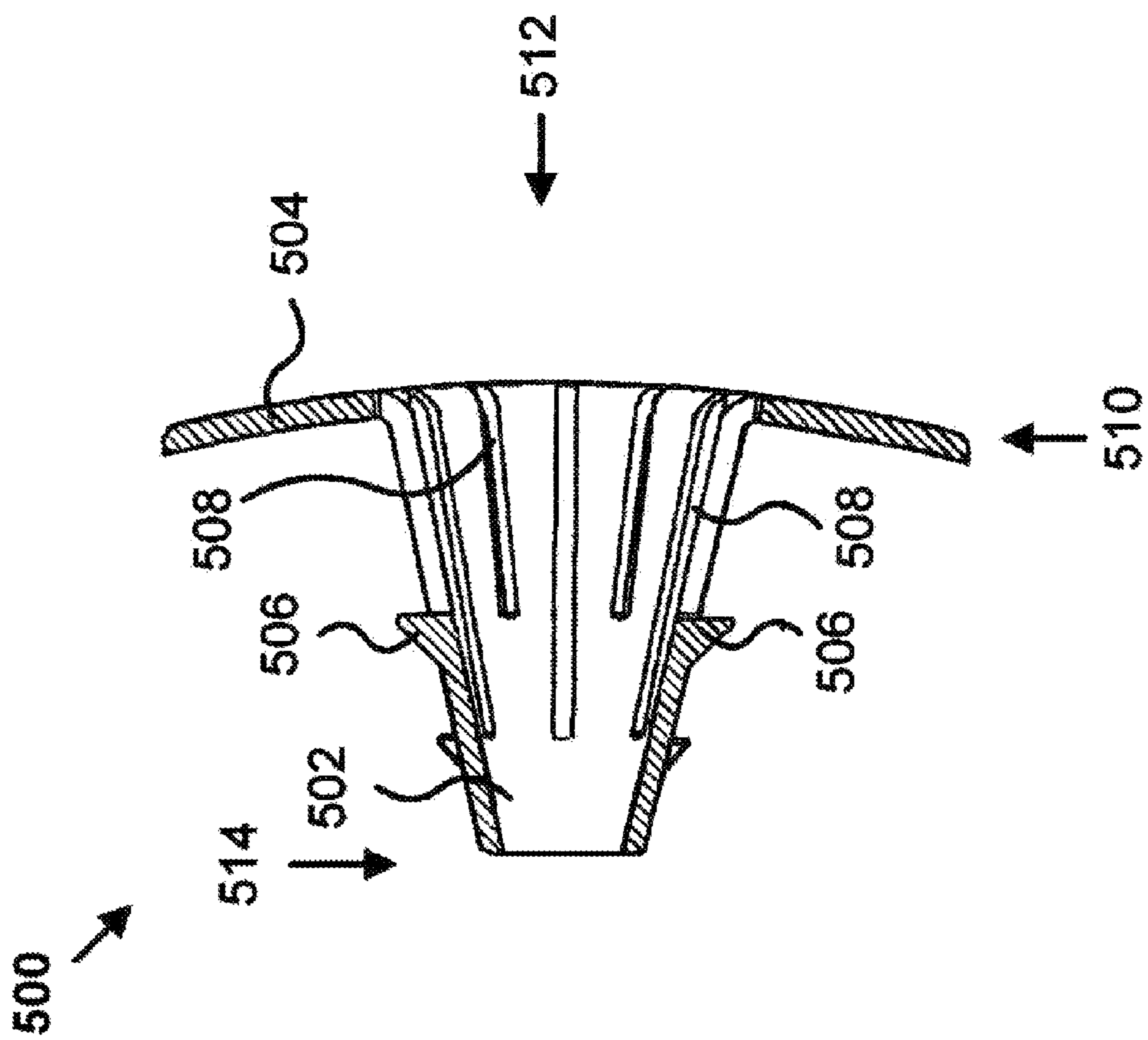

Fig 12

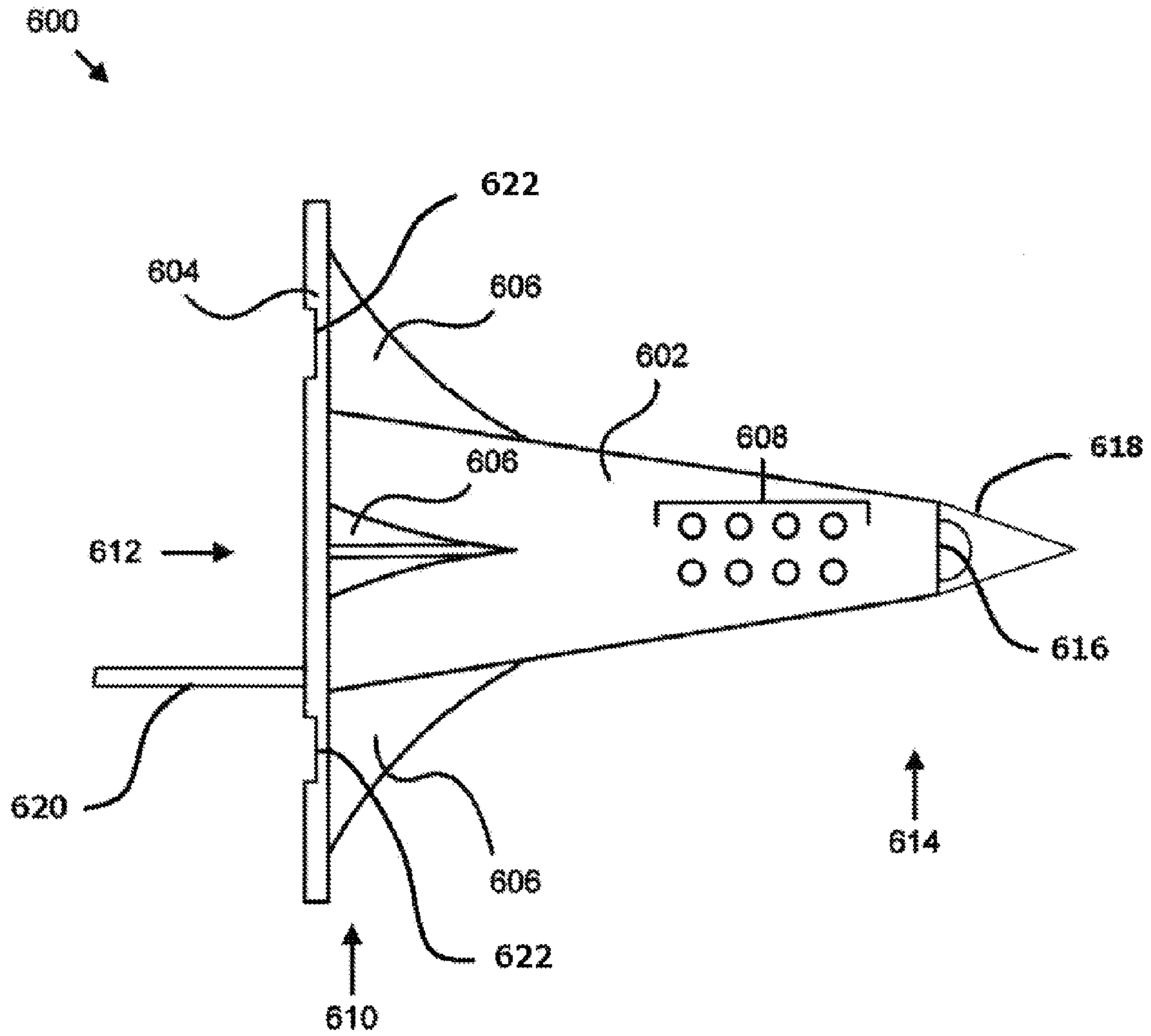

Fig 13

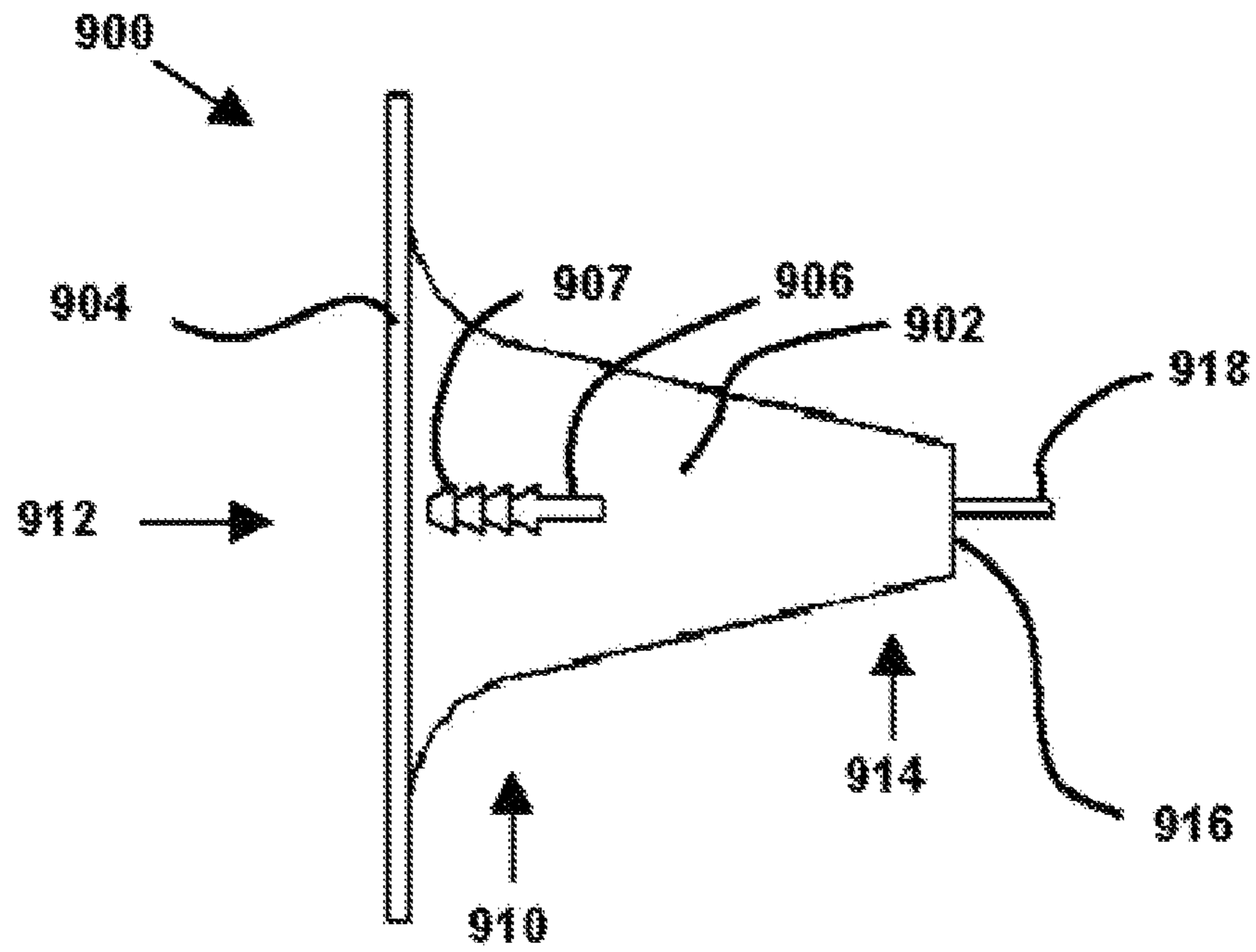

Fig 15

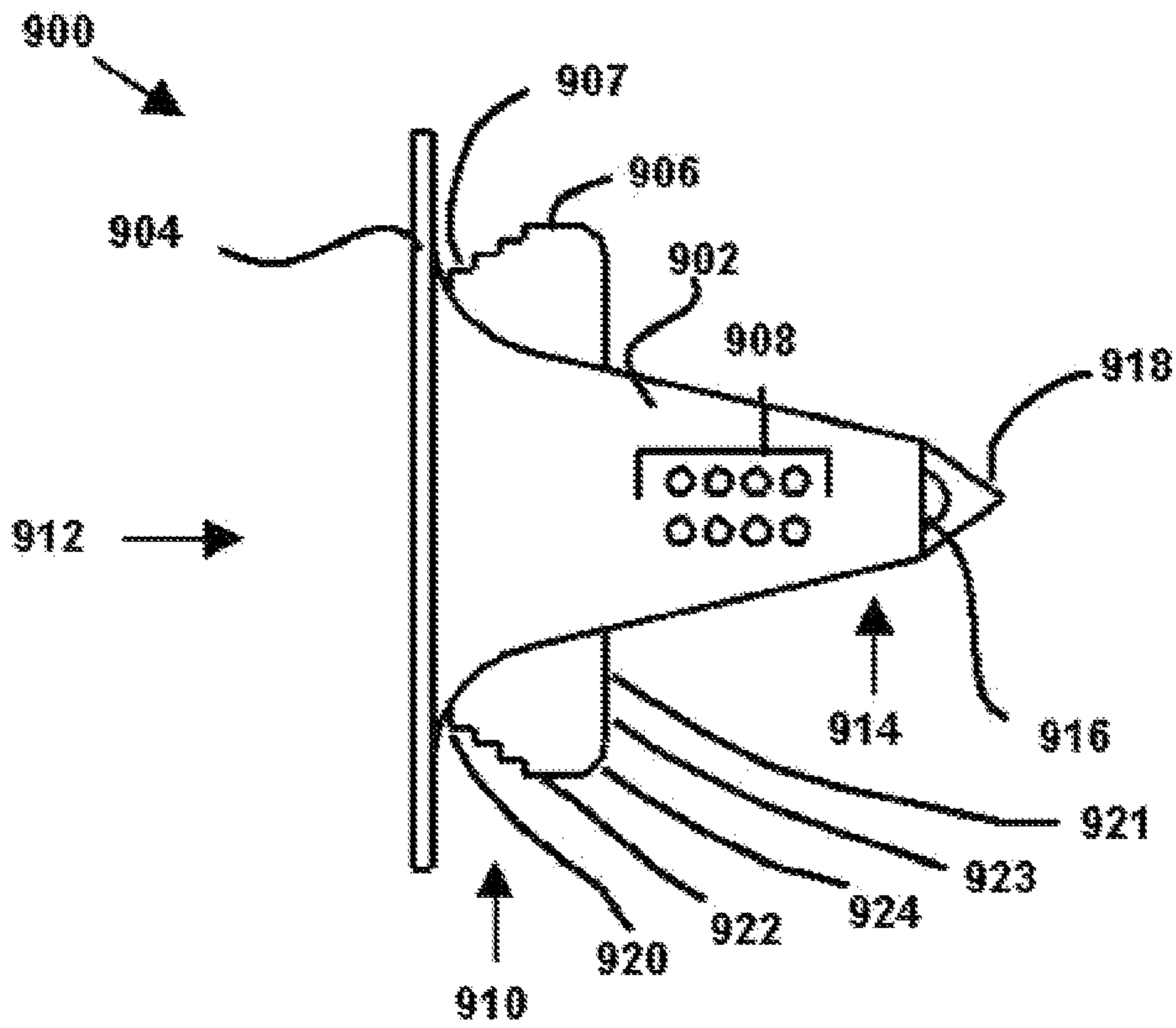

Fig 14

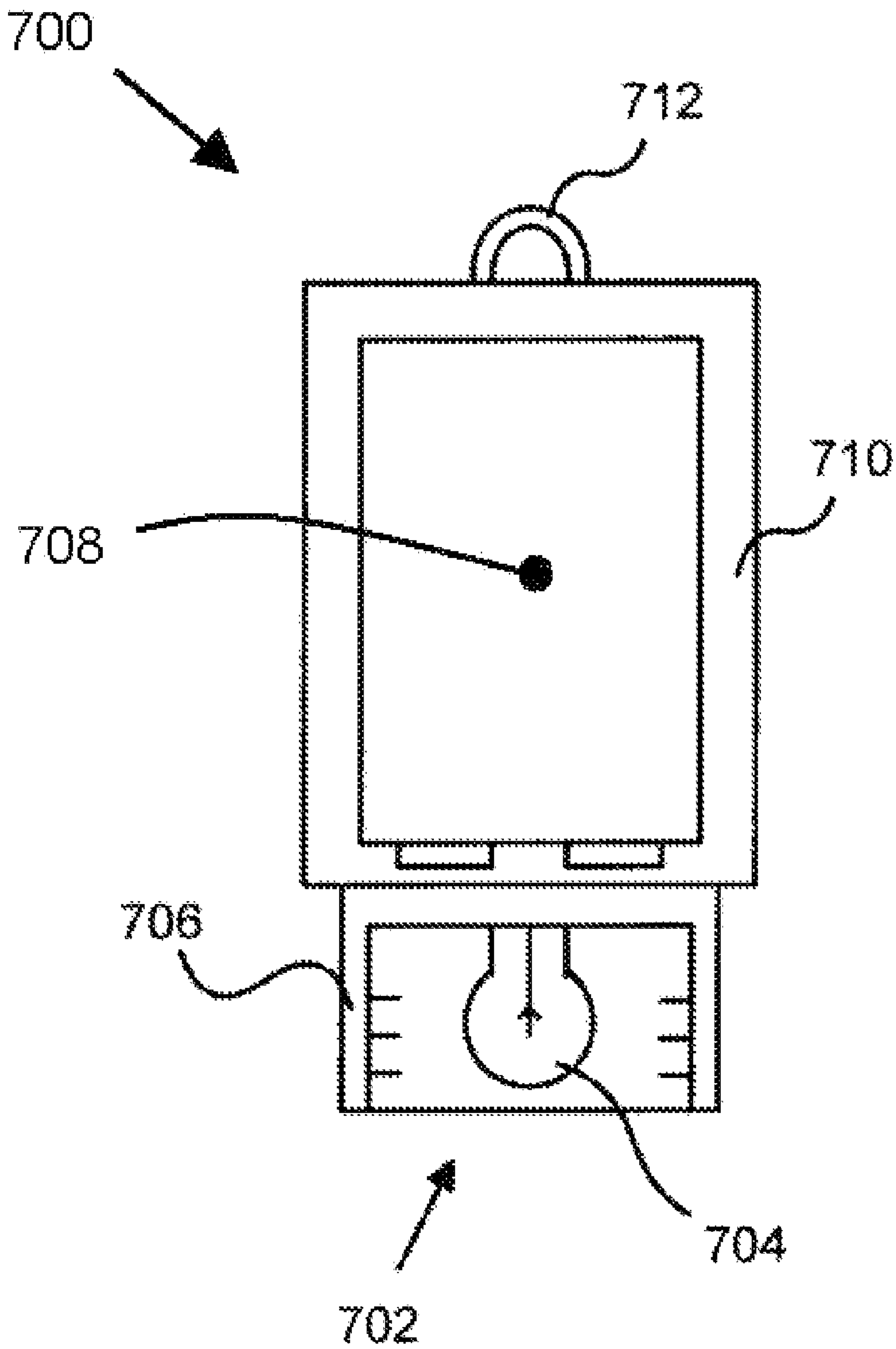

Fig 16

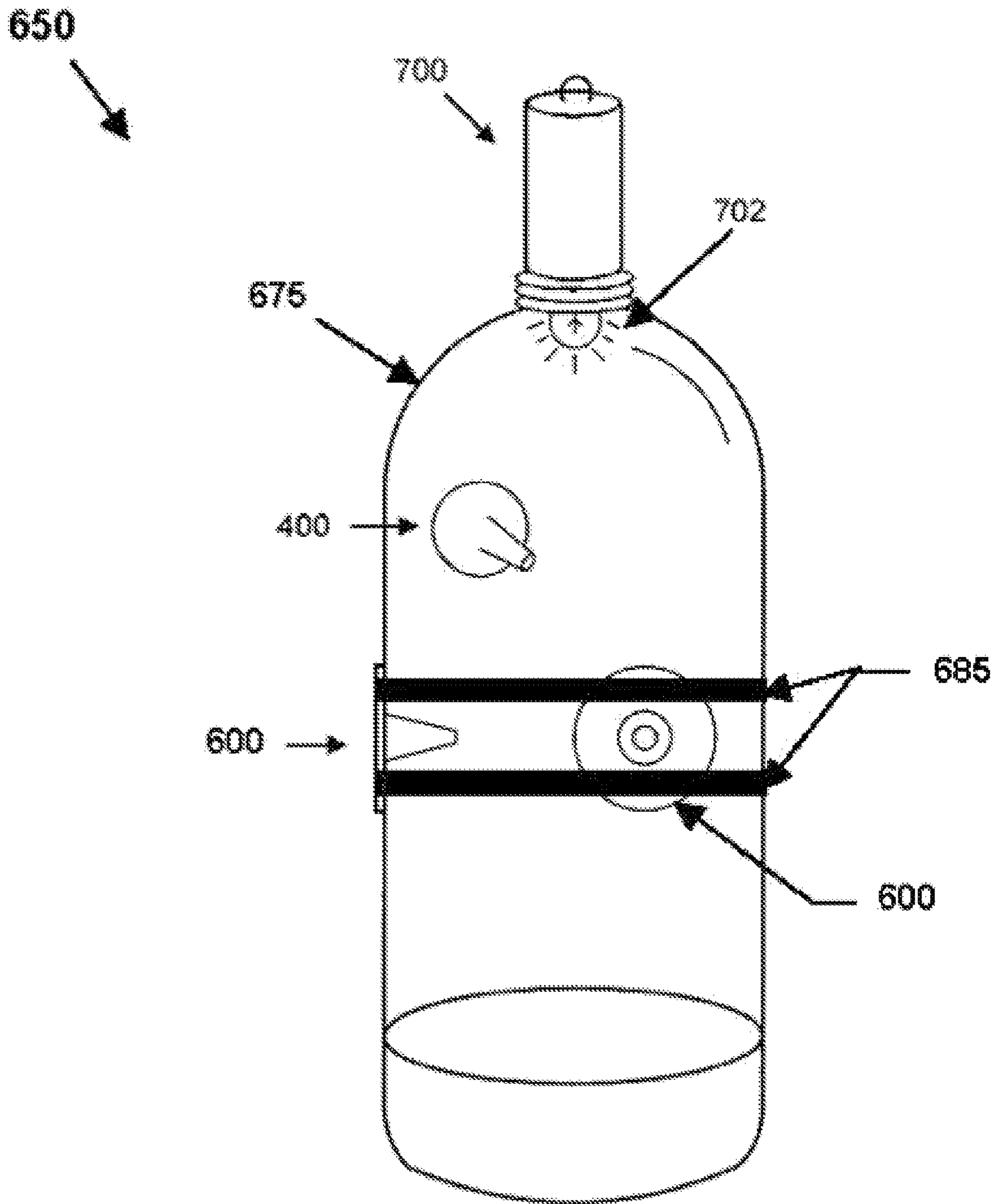

Fig. 17

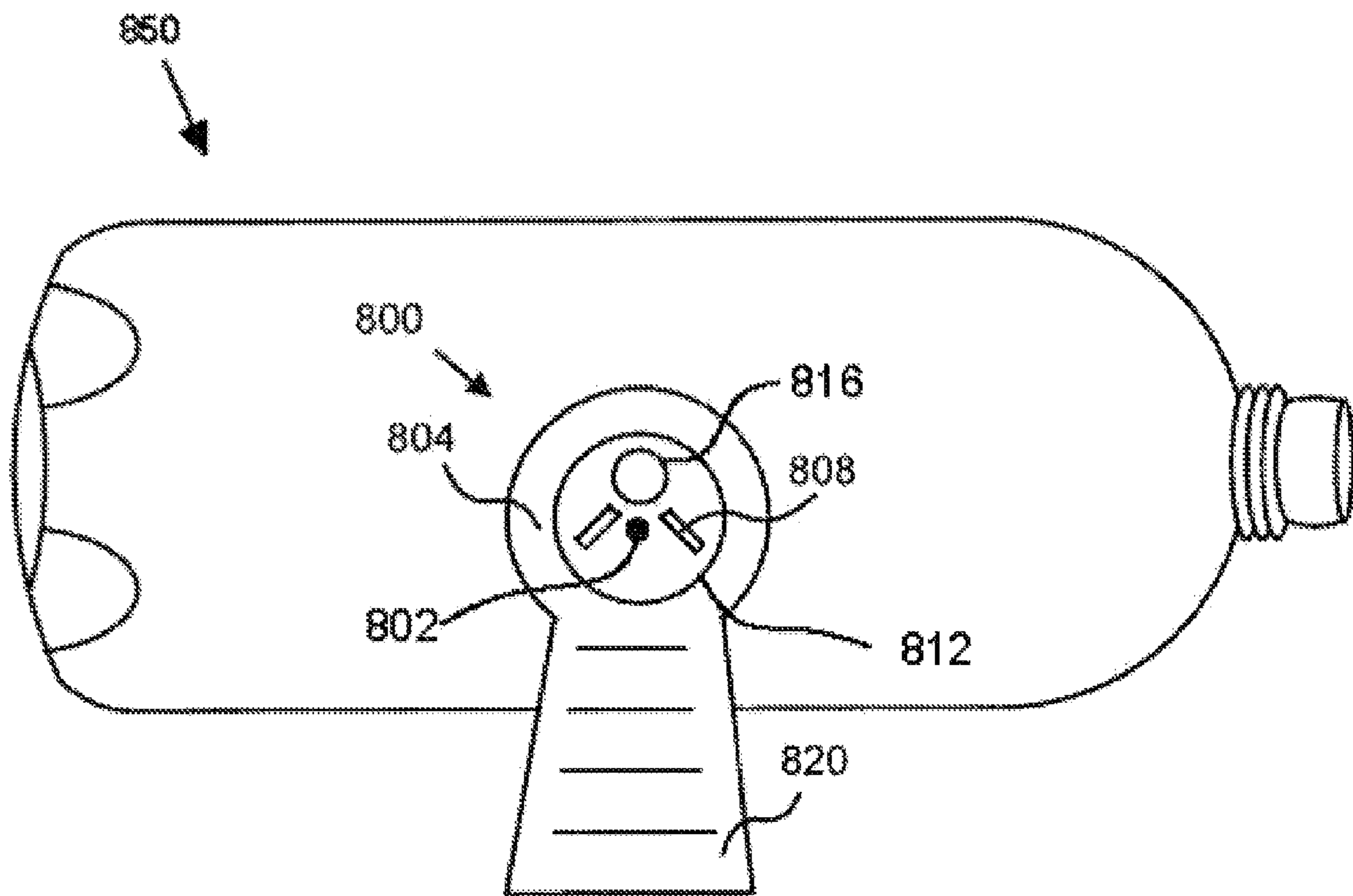

Fig 18

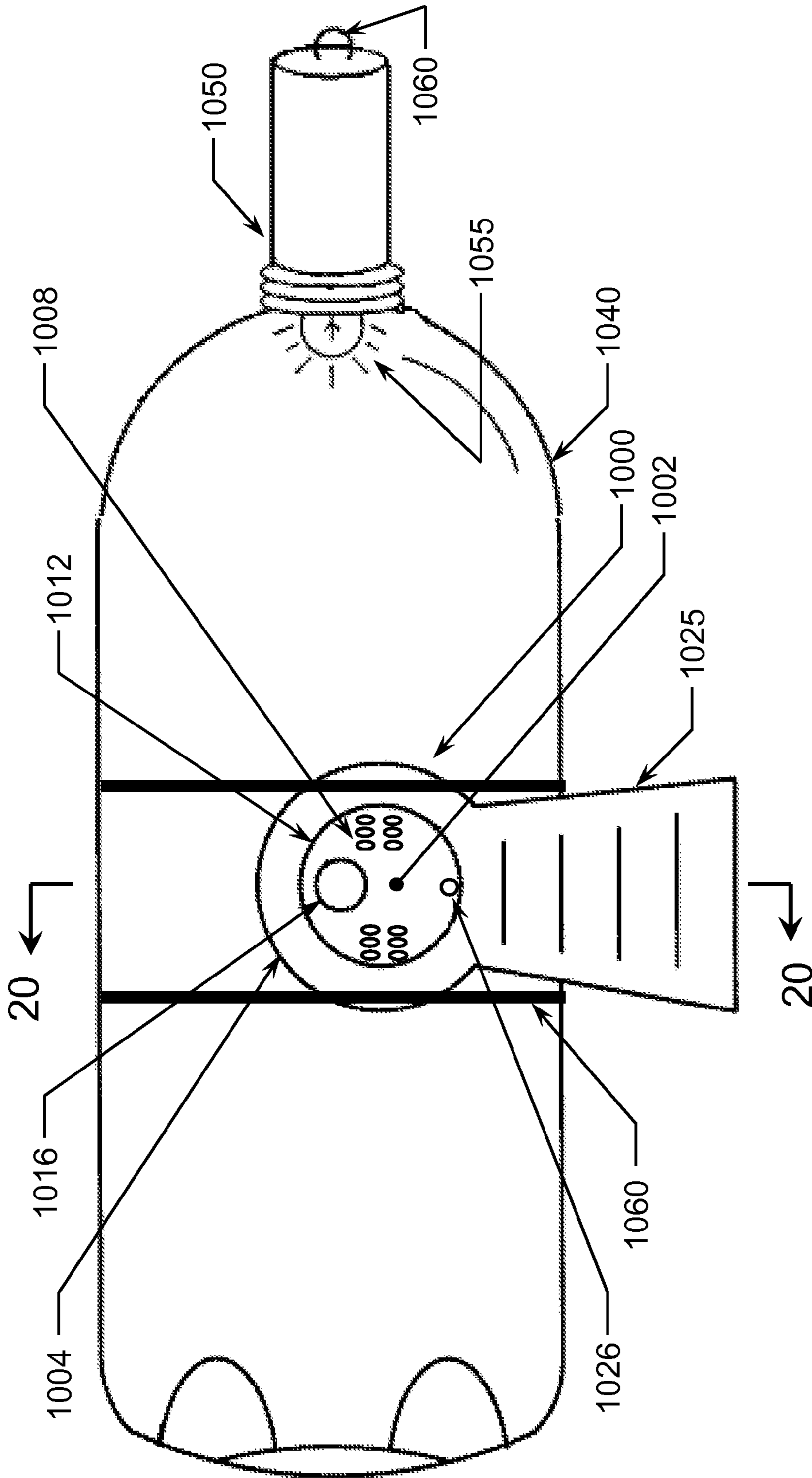

Fig 19

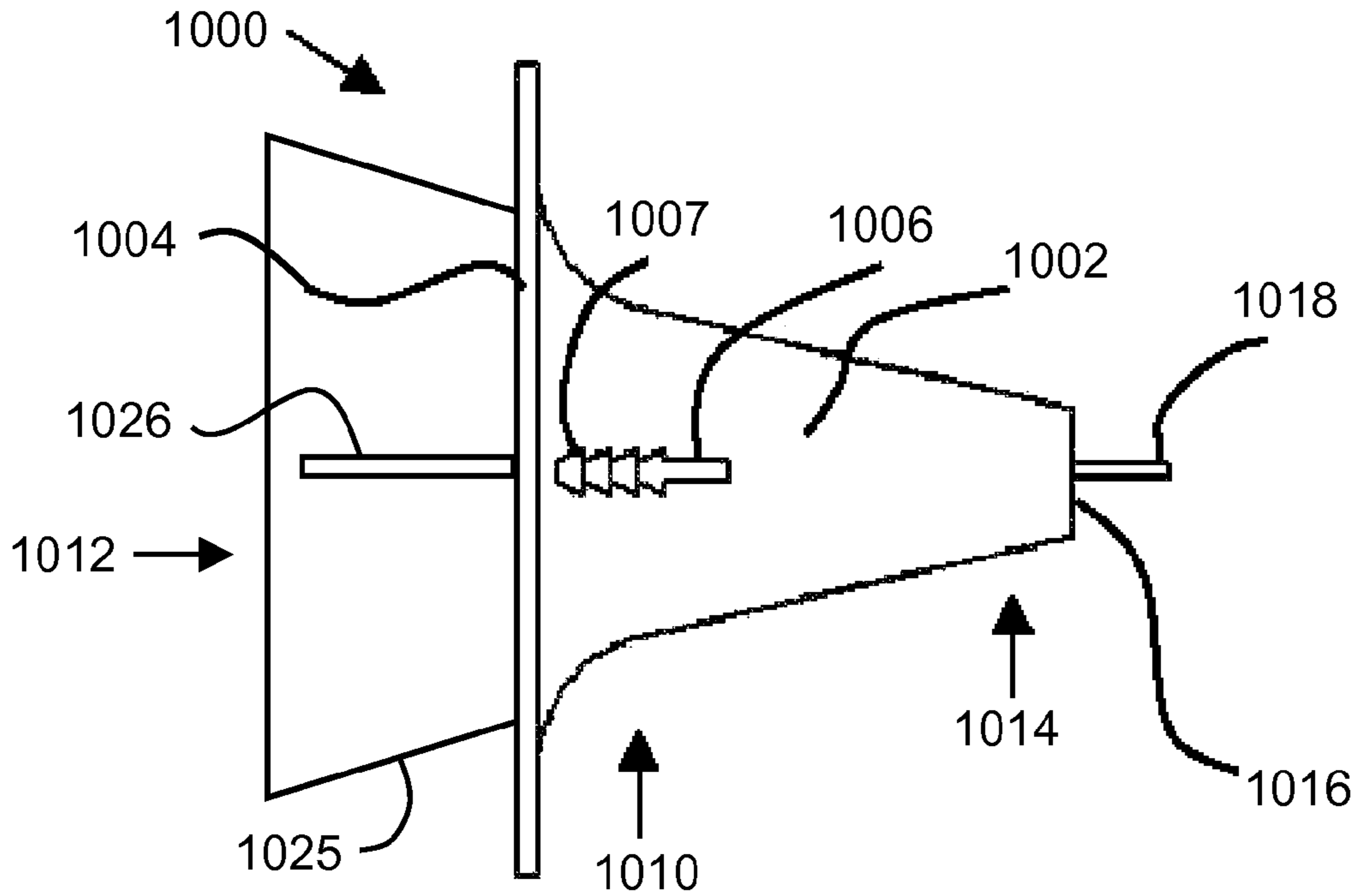

Fig 21

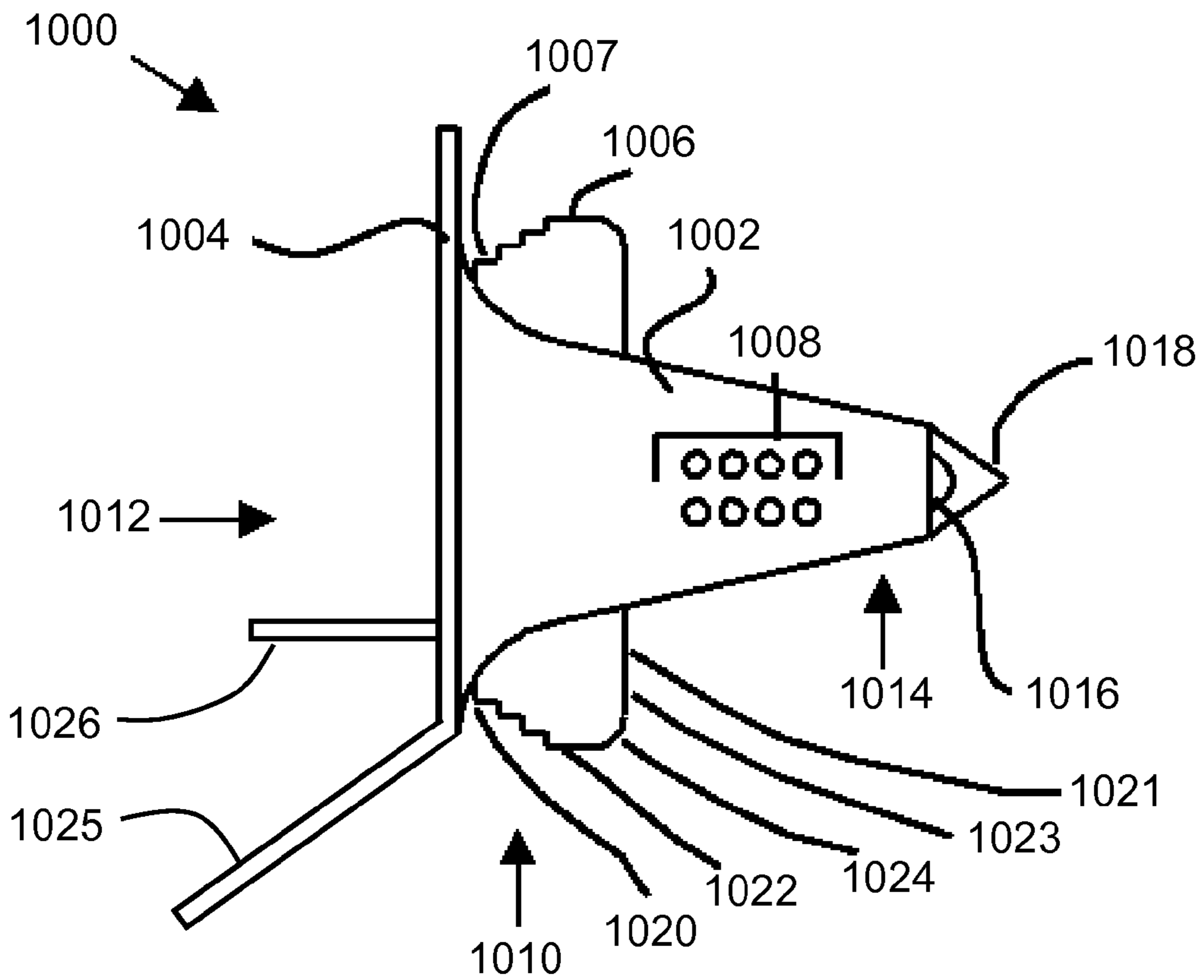

Fig 20

INSERTABLE PEST CATCHING DEVICE

This nonprovisional utility application is a continuation-in-part of application Ser. No. 11/111,626 filed Apr. 20, 2005 now U.S. Pat. No. 7,222,453 which was a nonprovisional utility application claiming priority to provisional application Ser. No. 60/565,678 filed Apr. 27, 2004, the specifications of which are incorporated herein by reference. The benefit of the filing date of these earlier filed applications is claimed under 35 U.S.C. § 119(e) and 35 U.S.C. § 120.

BACKGROUND OF THE INVENTION

1. Field of the Invention

This invention relates to devices used to catch pests and more particularly relates to devices that are inserted into a container in order to trap pests inside a container.

2. Description of the Related Art

Pests, such as insects, rodents, slugs, and the like, frequently inhabit greenhouses, gardens, pantries, kitchens, or almost any area designated for human use or enjoyment. To alleviate problems caused by pests, traps have been designed to capture the bothersome creatures. A common pest outdoors is the hornet or wasp. The flying, stinging insects have caused early termination of many outdoor activities and have frustrated numerous gardeners. Many traps have been specially designed to catch wasps.

FIG. 1 illustrates a typical wasp trap **100** known in the art. The trap **100** includes a base **102** with openings **104** for the wasps to enter. The trap **100** further comprises an inverted funnel **106** inside of a container **108**. The container **108** is connected to the base **102** and may include a device **110** for hanging the trap **100**. An attractant may be placed within the base **102** to lure wasps. One drawback to the trap **100** is, the trap **100** must be cleaned to be reused or must be completely discarded. The apparatus is also bulky and must be stored when not in use. Furthermore, this type of trap **100** is typically for home use and is not easily transportable because the trap **100** must be cleaned. Also, the trap **100** is intended to be hung and cannot rest on a flat surface because of the design of the base **102**.

FIG. 2 illustrates another example of a wasp trap **200** known in the art. The trap **200** includes an entrance device **202** and a bag **204**. The wasps enter through the entrance device **202** and are trapped in the bag **204**. In some cases, an attractant may fill the bottom of the bag **204** to lure the wasps. Because the trap **200** has a single entrance on top of the bag **204**, the number of wasps entering the trap may be limited. Unlike the wasp trap **100**, the trap **200** is disposable. However, the trap **200** must be repurchased, which causes unnecessary expense and hassle. In addition, the bag **204** may not be attractive to onlookers, especially when full of wasps. Furthermore, the bag **204**, lacking a solid shape, must also be hung to function as a wasp trap.

FIG. 3 is another wasp trap **300** known in the art. The wasp trap **300** comprises a base container **302** and a covering **304** with an eyelet and string to hang the trap **300**. The base container **302** includes a plurality of holes **306** for wasps to enter the trap **300**. The holes **306** have a tapered opening leading into the container **302**. Consequently, the wasps may crawl into the holes **306** easily, but cannot exit the holes **306**. In addition, the base container **302** includes smaller holes **308** to allow the aroma of an attractant to lure wasps to the trap **300**. Though the trap **300** has an attractive appearance, the trap **300** must also be cleaned for reuse and is bulky to store and transport, similar to trap **100**.

From the foregoing discussion, it should be apparent that a need exists for a compact, cost-effective device that effectively captures pests, and in particular, wasps. Beneficially, such a device would be reusable but not require excessive cleaning. In addition, the device may be adaptable and may be used in a variety of locations and containers.

SUMMARY OF THE INVENTION

The present invention has been developed in response to the present state of the art, and in particular, in response to the problems and needs in the art that have not yet been fully solved by currently available pest traps. Accordingly, the present invention has been developed to provide an insertable device to trap pests inside a container that overcomes many or all of the above-discussed shortcomings in the art.

The device is preferably configured to be inserted into a container. In one embodiment, the container may be a disposable two liter plastic bottle. Alternatively, the container may be a milk jug, cardboard box, or other disposable container. In a preferred embodiment, the device is inserted into an opening in the side of the container. As a result, a plurality of devices may be inserted into a single container. In select embodiments, the device may be configured to be inserted into permanent enclosures, such as eaves of a building, pipes, posts, walls, etc.

The insertable device preferably comprises a funnel with a first and second end. The first end may have a wider opening than the second end. The first end may further include a flange configured to engage a wall of the container. In certain embodiments, except for the opening created by the funnel itself, the flange may seal the opening into the container. Preferably, the flange blocks the opening so insects do not escape from the container. The device may also include one or more protruding members extending from the external surface of the funnel. The protruding members are preferably configured to secure the funnel to the container. In certain embodiments, the funnel may comprise apertures to allow the aroma of an attractant to permeate the inside of the funnel.

Reference throughout this specification to features, advantages, or similar language does not imply that all of the features and advantages that may be realized with the present invention should be or are in any single embodiment of the invention. Rather, language referring to the features and advantages is understood to mean that a specific feature, advantage, or characteristic described in connection with an embodiment is included in at least one embodiment of the present invention. Thus, discussion of the features and advantages, and similar language, throughout this specification may, but do not necessarily, refer to the same embodiment.

Furthermore, the described features, advantages, and characteristics of the invention may be combined in any suitable manner in one or more embodiments. One skilled in the relevant art will recognize that the invention can be practiced without one or more of the specific features or advantages of a particular embodiment. In other instances, additional features and advantages may be recognized in certain embodiments that may not be present in all embodiments of the invention.

These features and advantages of the present invention will become more fully apparent from the following description and appended claims, or may be learned by the practice of the invention as set forth hereinafter.

DESCRIPTION OF DRAWINGS

In order that the advantages of the invention will be readily understood, a more particular description of the invention

3

briefly described above will be rendered by reference to specific embodiments that are illustrated in the appended drawings. Understanding that these drawings depict only typical embodiments of the invention and are not therefore to be considered to be limiting of its scope, the invention will be described and explained with additional specificity and detail through the use of the accompanying drawings, in which:

FIG. 1 is a perspective view of one embodiment of a wasp trap known in the art;

FIG. 2 is a perspective view of another embodiment of a wasp trap known in the art;

FIG. 3 is a perspective view of yet another embodiment of a wasp trap known in the art;

FIG. 4 is a perspective view of one embodiment of an insertable device in accordance with the present invention with phantom lines representing tangencies of surfaces; the device is shown positioned such that the front face of the device is located at the top of the figure;

FIG. 5 is a perspective view of one embodiment of a two liter disposable bottle with a plurality of insertable devices of the present invention inserted into the side of the bottle, a portion of the bottle being shown as substantially transparent so as to reveal the insertable devices that are inserted on the far side of the figure;

FIG. 6 is an orthographic side view of one embodiment of an insertable device in accordance with the present invention;

FIG. 7 is an orthographic front view of one embodiment of an insertable device in accordance with the present invention;

FIG. 8 is a cross-sectional view of one embodiment of an insertable device in accordance with the present invention;

FIG. 9 is a close-up view of a protruding member shown in FIG. 8 in accordance with the present invention;

FIG. 10 is an orthographic side view of an alternative embodiment of an insertable device in accordance with the present invention;

FIG. 11 is a front orthographic view of the embodiment illustrated in FIG. 10;

FIG. 12 is a cross-sectional view of the embodiment illustrated in FIG. 10;

FIG. 13 is a side orthographic view of an alternative embodiment of an insertable device in accordance with the present invention;

FIG. 14 is a side orthographic view of an alternative embodiment of an insertable device in accordance with the present invention;

FIG. 15 is a top orthographic view of the alternative embodiment of an insertable device depicted in FIG. 14;

FIG. 16 is a cross-sectional side view of one embodiment of a lighted cap in accordance with the present invention—cross-hatching is not shown for clarity;

FIG. 17 is a perspective view of a disposable plastic bottle with multiple devices inserted in the side of the bottle, two of the devices are shown retained by a rubber band, and with a lighted cap in accordance with the present invention; a portion of the bottle being shown as substantially transparent so as to reveal the light and insertable devices and that are inserted on the far side of the figure;

FIG. 18 is a perspective view of one embodiment of an insertable device in accordance with the present invention inserted into a disposable plastic bottle.

FIG. 19 is a side view of an alternate embodiment of the insertable pest catching device shown inserted and retained in the wall of a disposable plastic bottle having a light emitting cap and an eyelet;

4

FIG. 20 is a sectional view of the embodiment shown in FIG. 19, with the viewing plane indicated in FIG. 20 by section arrows 20, and;

FIG. 21 is a top view of the embodiment shown in FIG. 19.

DETAILED DESCRIPTION OF THE INVENTION

Reference throughout this specification to “one embodiment,” “an embodiment,” or similar language means that a particular feature, structure, or characteristic described in connection with the embodiment is included in at least one embodiment of the present invention. Thus, appearances of the phrases “in one embodiment,” “in an embodiment,” and similar language throughout this specification may, but do not necessarily, all refer to the same embodiment.

Furthermore, the described features, structures, or characteristics of the invention may be combined in any suitable manner in one or more embodiments. In the following description, numerous specific details are included to provide a thorough understanding of embodiments of the invention. One skilled in the relevant art will recognize, however, that the invention can be practiced without one or more of the specific details, or with other methods, components, materials, and so forth. In other instances, well-known structures, materials, or operations are not shown or described in detail to avoid obscuring aspects of the invention.

FIG. 4 illustrates one embodiment of an insertable device 400 that inserts into a container. The device 400 includes a funnel 402, a flange 404, protruding members 406, and apertures 408. A first end 410 of the device 400 may comprise a wider opening 412, and a second end 414 of the device 400 may comprise a narrower opening 416. The insertable device 400 is preferably reusable and may be made from any suitable material, such as plastic, metal, wood, rubber, or the like.

Preferably, the second end 414 of the insertable device 400 is inserted into a hole in a container such that the narrow opening 416 opens into the interior of the container. Preferably, the container has a wall that is penetratable or deformable. For example, a container may comprise a disposable two liter plastic bottle, such as the type of container in which soda pop is sold. A user is preferably able to cut or create a hole or opening in the wall of the container. As a result, the user may insert the device 400 into the wall of the container. In one embodiment, the device 400 may include a blade or pointed member to create a hole or slit in a container.

Because the device 400 is inserted into the side of a container, one or more devices 400 may be inserted into a single container. Consequently, the user may customize a container according to the need for an insect trap. Preferably, the device 400 is removable from the container and may be reused. The container is preferably disposable and may be discarded after use. Also, the size of the device 400 is preferably compact enough to be transported and stored easily. In certain embodiments, the device 400 is stackable.

FIG. 5 illustrates one embodiment of a two liter plastic bottle 450 with a plurality of insertable devices 400 inserted into the side of the bottle 450. Bottle 450 further includes lid 460 sealingly and detachably attached to bottle 450. Bottle 450 having lid 460 attached to bottle 450 and at least one insertable device 400 inserted in a wall of bottle 450 comprises pest catching apparatus 470. Insects may enter the bottle 450 simultaneously through different insertable devices 400. To lure insects into the bottle 450, an attractant 452 may be placed in the bottom of the container 450. Known attractants include sugar water, food, manufactured attractants, and the like. The vapors of the attractant 452 preferably

5

escape through the insertable devices **400**. Multiple devices **400** permit a greater amount of attractant vapors to escape the container **450**.

The funnel **402** gradually tapers from a wider opening **412** to a narrower opening **416** such that pests may enter the device **400** from the wider opening **412** and then proceed through the funnel **402** to enter the bottle **450** from the narrower opening **416**. Preferably, the narrower opening **416** is sized relative to the type of pest being trapped, such that opening **416** is sufficiently large enough for the intended pest to enter into bottle **450** through opening **416**, but not so large that the intended pest may easily escape bottle **450** through opening **416**. Consequently, the pest is not easily able to exit the container **450** through the narrow opening **416**, since the creature typically tries to exit through the transparent walls of the container **450** or through the apertures **408** in the funnel **402**.

Referring back to FIG. **4**, the funnel **402** may further comprise a flange **404** attached at the first end **410** of the device **400**. The flange **404** is preferably configured to engage a wall of the container **450**. In one embodiment, the flange **404** is wide and circumscribes the opening **412** of the funnel **402**. In a further embodiment, the flange **404** may seal the portion of the opening in the wall of the container **450** defined by the open passage between the bottle wall and funnel **402** outer surface that would otherwise not be sealed. Alternatively, the flange **404** may simply block the opening of the container such that insects do not escape from the container **450**. Accordingly, the flange **404** may have various sizes, thicknesses, and profiles to accommodate different containers and openings. In one embodiment, the flange **404** is curved to further enhance the ability of the device **400** to close off gaps in the wall of the container **450**. The funnel first end **410** and second end **414** define a longitudinal axis of the funnel therebetween and the flange **404** is curved such that it forms a portion of a cylindrical wall (see FIG. **6**), and wherein an axis of the cylindrical wall portion is substantially perpendicular to the longitudinal axis of the funnel **402** and extends through the funnel **402**. Alternatively, the flange **404** may be flat. In a further embodiment, multiple flanges **404** may extend from the funnel **402**.

In one embodiment, the flange **404** may include one or more grooves (not shown) across the face. The grooves may be configured to receive a rubber band or strap. Consequently, a rubber band may be used to help secure the insertable device **400** to the container **450**. A rubber band, in one embodiment, is extended around the container **450** and is placed on top of a device **400** inserted into a container **450**. Preferably, one rubber band is placed in a groove of the flange **404** above the opening **412**, and another rubber band is placed in a groove below the opening **412**. The retracted rubber bands firmly retain the insertable device **400** in an opening in the wall of the container **450**. The grooves in the flange **404** preferably prevent the rubber bands from falling off of the device **400**.

In an alternative embodiment, an adhesive or fastener may be used to attach the insertable device **400** to a container **450**. For example, tape, double-sided tape, Velcro®, glue, or the like may be used to fasten the back surface of the flange **404** to the wall of a container **450**. In one embodiment, thick glue may be applied to the flange **404** to attach the device **400** to the container **450** such that the opening in the wall of the container **450** may be sealed. In certain instances, the insertable device **450** may be discarded with the container **450**. Alternatively, an adhesive may be reapplied to an insertable device **400**, and the device **400** may thus be reusable.

In certain embodiments, the face of the flange **404** may contain one or more recognizable symbols **418**. In one

6

embodiment, the symbol **418** may comprise words or a trademark. Alternatively or in addition, the symbol **418** may be a shape of a particular insect, such as a fly, wasp, bee, or the like. The symbol **418** may correspond to the type of insect the device **400** is designed to help capture. Alternatively, the symbol **418** may simply be a decorative design. In a further embodiment, the flange **404** may also be shaped to resemble a recognizable object. For example, the flange **404** may be shaped as flower petals.

As mentioned previously, the flange **404** preferably engages the wall of the container **450** to hold the device **400** in place. In addition, protruding members **406** may also be configured to secure the device **400** to the container **450**.

FIG. **6** further illustrates a side view of the insertable device **400**. The protruding members **406** in the depicted embodiment resemble additional flanges circumscribing the funnel **402**. The protruding members **406** may also engage the wall of the container **450**. How the flange **404** and the protruding members **406** engage the wall of the container **450** depend on the type of container **450** as well as the kind of opening in the container **450**.

For example, the device **400** may engage a circular hole in a container **450** differently than a slit in the wall of the container **450**. In the case of a circular hole, the wall of the container **450** may rest between the flange **404** and a first protruding member **406a**. Alternatively, a container wall that is slit may contact the flange **404** and slope to contact a third protruding member **406c**. Consequently, the flange **404** and protruding members **406** are preferably designed to function with a variety of openings and types of containers **450**.

The insertable device **400** may comprise one or more protruding members **406**. A plurality of protruding members **406** may be provided to allow the device **400** to be adaptable. However, in select embodiments, the insertable device **400** may not include protruding members **406**. As discussed previously, the insertable device **400** may be fastened to a container **450** with an adhesive or a fastener. Thus, the insertable device **400** may rely on the adhesive to secure the device **400** to the container **450**.

Also mentioned, the funnel **402** may additionally include apertures **408**. The apertures **408** preferably permit the odor of an attractant **452** within the container **450** to permeate the funnel **402**. In one embodiment, the apertures **408** are holes.

FIG. **7** illustrates a front view of one embodiment of an insertable device **400**. The symbols **418** are depicted on the surface of the flange **404**. Additionally, apertures **408** are shown from within the funnel **402**. In one embodiment, the apertures **408** are positioned near the second end of the insertable device **400**. Consequently, insects are lured toward the narrow opening **416** of the funnel **402**. Preferably, the apertures **408** are sized to correspond to a particular type of insect, so the insects cannot escape through the apertures **408**.

In one embodiment, a screen or net (not shown) may cover or replace the apertures **408** such that insects cannot crawl through the holes **408**. The screen may cover the apertures **408** from the inside of the funnel **402** or from the outside of the funnel **402**. Thus, the aroma of the attractant may escape the container **450** through the apertures **408** in the device **400**. In a further embodiment, a removable apparatus or covering with a screen may be adaptable to a particular device **400** to cover the apertures **408**. Consequently, the user may choose to apply a screen to the apertures **408** to capture smaller insects.

FIG. **8** is a cross-sectional view of one embodiment of an insertable device **400** further illustrating the apertures **408**. Also illustrated are the flange **404** and protruding members **406**. In the depicted embodiment, the flange **404** and protrud-

ing members **406** are made from the same material as the funnel **402** and have been molded at the time of manufacture. In an alternative embodiment, the flange **404** and/or protruding members **406** may be welded to the funnel **402**. Furthermore, the protruding members **404**, **406** may be attached with an adhesive or other form of fastener.

FIG. **9** illustrates in greater detail a protruding member **406**. The angle of the funnel **402** tapers toward the second end. The protruding members **406** may be located in a plane parallel to a face defined by the wide opening of the funnel **402**.

FIGS. **10-12** illustrate an alternative embodiment of an insertable device **500**. The device **500** comprises a funnel **502**, a flange **504**, protruding members **506**, and apertures **508**. The device **500** further includes a first end **510**, an opening **512**, a second end **514**, and a narrow opening **516**. In the depicted embodiment, the apertures **508** are slots that extend partially along the length of funnel **502**. Located near the second end **514** at one end of the slots **508** are protruding members **506**. The protruding members **506** may resemble barbs. In one embodiment, one or more protruding members **506** may include a sharpened edge or blade to cut an opening into a container **450**.

As discussed, the protruding members **506** preferably secure the insertable device **500** to a container. In one embodiment, the protruding members **506** are formed from the material removed from the slots **508** during manufacture. The slots **508** may encourage the insects to advance from the wider opening **512** to the narrower opening **516** and into the container.

The funnel **502** is preferably sized relative to the type or size of pest that is to be trapped. For example, the funnel **500** may be smaller to catch white flies, or larger to catch moths. In a contemplated embodiment, the funnel **502** may even be large enough to capture mice or other small rodents.

FIG. **13** illustrates yet another embodiment of an insertable device **600** in accordance with the present invention. The device **600** may include a funnel **602**, a flange **604**, protruding members **606**, and a screen **608**. The device **600** may further include a first end **610**, a larger opening **612**, a second end **614**, a narrow opening **616**, and a container piercing blade-like member **618**. In one embodiment, the protruding members **606** are positioned near the first end **610** and are attached to the flange **604**. The protruding members **606** may be sloped to engage the wall of a container when the device **600** is inserted into the container. Device **600** further includes an attractant support device **620**, for supporting meat or other attractants, protruding from device **600**. Flange **604** of device **600** further includes retention grooves **622** which provide for the mounting of device **600** to a container by placing an elastic band in a compressively retaining relationship to grooves **622** of device **600** and a container.

In one embodiment, the device **600** may include only two protruding members **606**. Accordingly, the protruding members **606** are configured to slide into a slit formed in the wall of a container such as the slit initiated by blade-like member **618**. The protruding members **606** consequently engage the wall of the container in the slit. As a result, the device **600** may be sufficiently secured to the container, while still permitting the device **600** to be easily removed.

As discussed, in certain embodiments, a screen **608** allows an attractant to escape the funnel **602**, while preventing small insects from crawling in and out of the slots. In the depicted embodiment, the screen **608** replaces the apertures to enhance dissemination of the attractant.

To help capture flying insects, a container with one or more insertable devices may be hung in an open area to attract the

insects. In one embodiment, a cap with an eyelet for hanging a container may be provided. The cap may further include a strap for hanging the container. In a contemplated embodiment, the cap may comprise a light source to attract insects.

FIG. **14** illustrates yet another embodiment of an insertable device **900** in accordance with the present invention. The device **900** may include a funnel **902**, a flange **904**, at least one protruding member **906** having at least one barb **907**, and a screen **908**. The device **900** may further include a first end **910**, a larger opening **912**, a second end **914**, a narrow opening **916**, and a container piercing blade-like member **918**. The at least one protruding member **906** extends in substantially a single plane which is parallel with a longitudinal axis of the insertable device **900**. The at least one protruding member **906** has a first end **920** which is located between the flange **904** and the at least one protruding member second end **921** along a longitudinal axis of the insertable device **900**. The at least one protruding member second end **921** is located between the at least one protruding member first end **920** and the funnel second end **914**. The at least one protruding member **906** having first **922** and second **923** edges and a corner **924** defined by an intersection of said first **922** and second **923** edges. The first edge **922** extending from the at least one protruding member first end **920** toward the corner **924**. The second edge **923** extending from the external surface of the funnel perpendicularly away from the longitudinal axis of the insertable device **900** to intersect the first edge **922** at the corner **924**, and the first edge **922** having the at least one barb **907** thereon which projects transversely from the substantially single plane in which at least one protruding member extends. Device **900** is adapted such that when device **900** is pressed against a container side wall, blade-like member **918** pierces a hole the container side wall. Device **900** is further adapted such that when device **900** is pressed into a container side wall hole, at least one barb **907** engages the container side wall to retain device **900** in an inserted position in the container.

As discussed, in certain embodiments, a screen **908** allows an attractant to escape the funnel **902**, while preventing small insects from crawling in and out of the slots. In the depicted embodiment, the screen **908** replaces the apertures to enhance dissemination of the attractant.

FIG. **16** illustrates one embodiment of a cap **700** with a light source **702** in accordance with the present invention. The cap **700** may be extended to include pertinent functioning components. A light bulb **704** may be located within a threaded cap **706**. Consequently, the light source **702** lights up the inside of a container, such as a two liter plastic bottle.

FIG. **17** illustrates insect catching apparatus **650** comprising a plastic bottle **675** with insertable devices **400** and **600** and a lighted cap **700**. Bottle **675** may be an empty two-liter volume soda pop bottle. When the cap **700** is screwed onto a bottle **675**, an activated light source **702** attracts insects to the bottle **675**. Such an embodiment may be useful to capture flies, fireflies, moths, mosquitoes, and the like. Enclosed areas, such as tents, greenhouses, storage areas, and the like, may especially benefit from a lighted insect trap. Further, FIG. **17** illustrates additional means of securing device **600** to bottle **675**. A first additional means of securing device **600** to bottle **675** is the placement of elastic band **685** in compressive retention relationship to grooves **622** of device **600**. A second additional means of securing device **600** to bottle **675** is by placing an adhesive between flange **604** and bottle **675** such that device **600** is adhered to bottle **675**.

Referring back to FIG. **16**, the light bulb **704** may be powered by a battery **708**, such as a nine-volt battery. As depicted, the cap **700** may be extended to house the battery

708. The housing **710** may resemble various shapes and may be made from plastic or other suitable material. The cap **700** may further include an eyelet **712** to hang the container if desired.

The light source **702** within the cap **700** may have various characteristics. In one embodiment, the light source **702** may have multiple modes, such as blinking, sustained, bright, photo switch, timed lighting, and the like. In addition, the light source **702** may be waterproof. In one embodiment, the light source **702** is a Light-Emitting Diode (LED) light powered by a battery **708**. In a further embodiment, the light source **702** may be embodied in an adaptable device that may be placed in various locations throughout the container, such as the bottom of the container or on the side of the container.

The present invention may be adaptable to function in multiple situations. For example, the insertable device may be used to capture crawling pests as well. A container, such as a bottle **450**, with an insertable device may be placed on the ground. In one embodiment, the trap may include a ramp to lead slugs, roaches and other crawling insects, and/or rodents into the trap.

FIG. **18** illustrates one embodiment of an insertable device **800** with a ramp **820**. The device **800** is inserted into a two liter plastic bottle **850**. The device **800** may include a funnel **802**, a flange **804**, protruding members (not shown), and apertures **808**. The device **800** may further include a first end having a wider opening **812** and a second end having a narrower opening **816**. Consequently, the device **800** may be inserted into the side of a container **850**. An attractant or bait may be placed within the container **850**. Crawling insects or rodents may then crawl up the ramp **820** to enter the funnel **802**. Once inside of the container **850**, the insects or rodents are not able to exit through the narrow opening **816** of funnel **802**.

In certain instances, narrow opening **816** of the second end may include a one-way flap or covering that functions as a swinging door. The flap may permit a creature to enter the container **850** through the funnel **802**, but preferably prevents passage out of the container **850**.

In yet another embodiment, the container may include a decorative covering (not shown) to hide the captured insects from view. Alternatively or in addition, the container may also be decorated to appeal to the user and/or to hide the insects. In certain embodiments, the insertable device may include additional apparatus to close the opening of the funnel. For example, a flat circular member may be pivotally attached to the flange such that the circular member may be rotated to block the wide opening. Apparatus to close the wide opening of the funnel may be useful when discarding a container full of insects if the user does not intend to reuse the insertable device.

FIGS. **19** through **21** illustrate yet another embodiment of an insertable device **1000** in accordance with the present invention. The device **1000** may include a funnel **1002**, a flange **1004**, at least one retention member **1006** having at least one barb **1007**, and a screen **1008**, with flange **1004** being connected to funnel **1002**, and at least one retention member **1006** being connected to funnel **1002** and flange **1004**, and screen **1008** being formed in funnel **1002**. The device **1000** may further include a first end **1010**, a larger opening **1012**, a second end **1014**, a narrow opening **1016**, and a container piercing blade-like member **1018**. The at least one retention member **1006** extends in substantially a single plane which is parallel with a longitudinal axis of the insertable device **1000**. The at least one retention member **1006** has a first end **1020** which is located between the flange **1004** and the at least one protruding member second end **1021** along a

longitudinal axis of the insertable device **1000**. The at least one retention member second end **1021** is located between the at least one retention member first end **1020** and the funnel second end **1014**. The at least one retention member **1006** having first **1022** and second **1023** edges and a corner **1024** defined by an intersection of said first **1022** and second **1023** edges. The first edge **1022** extending from the at least one retention member first end **1020** toward the corner **1024**. The second edge **1023** extending from the external surface of the funnel perpendicularly away from the longitudinal axis of the insertable device **1000** to intersect the first edge **1022** at the corner **1024**, and the first edge **1022** having the at least one barb **1007** thereon which projects transversely from the substantially single plane in which at least one protruding member extends. Device **1000** is adapted such that when device **1000** is pressed against a container side wall, blade-like member **1018** pierces a hole the container side wall. Device **1000** is further adapted such that when device **1000** is pressed into a container side wall hole, at least one barb **1007** engages the container side wall to retain device **1000** in an inserted position in the container. It is noted that device **1000** may optionally be provided without funnel **1002**, in which case, once a pest passes through opening **1012**, the pest enters a container inner cavity.

Device **1000** further includes apertures **1008** located in funnel **1002** to allow an attractant aroma to escape the funnel **1002**, while preventing small insects from crawling in and out of the apertures. Device **1000** further includes an attractant support **1026** extending from flange **1004** to provide support for a replaceable attractant such as a piece of raw meat or the like. It is also noted that flange **1004** of device **1000** is preferably substantially similar to flange **404** of device **400** as shown in FIGS. **6** through **8**, in that flange **1004** is curved to adapt to the external surface of a container surface such as the cylindrical surface of a two liter volume soda pop bottle. However, flange **1004** may alternately be substantially flat as shown in FIGS. **20** and **21**. Device **1000** also includes ramp **1025** connected to and extending from flange **1004**. When device **1000** is inserted into a container and placed on a surface such as the ground, ramp **1025** provides for crawling insect and like creature ingress into the container.

FIG. **19** illustrates the insertion of device **1000** into a two liter volume type plastic soda pop bottle **1040**. Device **1000** is retained to bottle **1040** by at least one retention member **1006** and at least one barb **1007**. Device **1000** is also secured to bottle **1040** by means of at least one rubber band **1060** or like elastomeric strap being placed in compressive retention relationship to flange **1004** and bottle **1040**. Device **1000** may be further secured to bottle **1040** by means of an adhesive being placed between flange **1004** and bottle **1040** so as to bond device **1000** to bottle **1040**. It is noted that bottle **1040** includes lighted cap **1050** having a light bulb **1055** and an eyelet **1060**. It is noted that lighted cap **1050** is substantially identical to cap **700**. It is also noted that bottle **1040** preferably includes an odor producing attractant contained within bottle **1040**.

The present invention may be embodied in other specific forms without departing from its spirit or essential characteristics. The described embodiments are to be considered in all respects only as illustrative and not restrictive. The scope of the invention is, therefore, indicated by the appended claims rather than by the foregoing description. All changes which come within the meaning and range of equivalency of the claims are to be embraced within their scope.

I claim:

1. An insertable pest trapping apparatus for inserting into a container in order to trap pests inside a container, said apparatus comprising:

a funnel having a first end and a second end which define a longitudinal axis of said funnel therebetween, said first end having a wide opening and said second end having a narrow opening;

a flange attached to said first end of said funnel, said flange being curved such that said flange forms a portion of a cylindrical wall, and wherein an axis of said cylindrical wall portion is substantially perpendicular to said axis of said funnel and extends through said funnel; and

at least one retention member extending from an external surface of said funnel, said at least one retention member being configured so as to secure said funnel to a container when said apparatus is at least partially inserted into a container wall.

2. The apparatus of claim **1**, wherein said apparatus further includes at least one member of the following group of members connected to said apparatus, said group of members comprising an attractant support member, a blade member, and a ramp member.

3. The apparatus of claim **2**, wherein said attractant support member includes an attractant supported on said attractant support member, and wherein said ramp member extends from said flange and wherein said ramp member facilitates ingress of a pest into said funnel, and wherein said blade member extends from said funnel second end, and wherein said blade member is adapted to pierce a plastic container wall when said blade member is pressed against the plastic container wall.

4. The apparatus of claim **2**, wherein said apparatus is combined with a container, and wherein said funnel is retentatively inserted into a wall of said container, and wherein said container is rested upon a support surface, and wherein said ramp member provides a bridge between said funnel and said support surface such that a pest may crawl from said support surface along said ramp member and into said funnel.

5. The apparatus of claim **2**, wherein said apparatus is combined with a container, and wherein said funnel is retentatively inserted into a wall of said container, and wherein said apparatus is further secured to said container by at least one of an elastomeric band and a layer of adhesive, and wherein said container defines a plastic bottle container, and wherein said container contains an odor generating attractant within said container, and wherein said container includes a light within said container, and wherein said container includes an eyelet from which said container may be suspended.

6. The apparatus of claim **1**, wherein said apparatus further includes at least one aperture in a surface of said funnel such that an attractant odor circulates through said funnel, when an odor generating attractant is in near proximity to said funnel.

7. The apparatus of claim **6**, wherein said at least one aperture defines a plurality of apertures, and wherein said plurality of apertures are of such a size that a pest is prevented from passing freely passing through one of said apertures.

8. The apparatus of claim **1**, wherein said at least one retention member includes at least one barb connected to said at least one retention member such that when said at least one retention member is at least partially pressed into the wall of the container, said at least one barb engages the wall of the container to secure said apparatus to the container.

9. The apparatus of claim **1**, wherein said apparatus is combined with a container, and wherein said funnel is retentatively inserted into a wall of said container.

10. An insertable pest trapping apparatus for inserting into a container in order to trap pests inside a container, said apparatus comprising:

a funnel having a first end and a second end which define a longitudinal axis of said funnel therebetween, said first end having a wide opening and said second end having a narrow opening;

a flange attached to said first end of said funnel, said flange being curved such that said flange forms a portion of a cylindrical wall, and wherein an axis of said cylindrical wall portion is substantially perpendicular to said axis of said funnel and extends through said funnel; and

at least one retention member extending from an external surface of said funnel, said at least one retention member being configured so as to secure said funnel to a container when said apparatus is at least partially inserted into a container wall; and wherein said apparatus includes at least one member of the following group of members connected to said apparatus, said group of members comprising an attractant support member, a blade member, and a ramp member.

11. The apparatus of claim **10**, wherein said attractant support member includes an attractant supported on said attractant support member, and wherein said ramp member extends from said flange and wherein said ramp member facilitates ingress of a pest into said funnel, and wherein said blade member extends from said funnel second end, and wherein said blade member is adapted to pierce a plastic container wall when said blade member is pressed against the plastic container wall.

12. The apparatus of claim **10**, wherein said apparatus further includes at least one aperture in a surface of said funnel such that an attractant odor circulates through said funnel, when an odor generating attractant is in near proximity to said funnel.

13. The apparatus of claim **12**, wherein said at least one aperture defines a plurality of apertures, and wherein said plurality of apertures are of such a size that a pest is prevented from passing freely passing through one of said apertures.

14. The apparatus of claim **10**, wherein said at least one retention member includes at least one barb connected to said at least one retention member such that when said at least one retention member is at least partially pressed into the wall of the container, said at least one barb engages the wall of the container to secure said apparatus to the container.

15. The apparatus of claim **10**, wherein said apparatus is combined with a container, and wherein said funnel is retentatively inserted into a wall of said container.

16. The apparatus of claim **10**, wherein said apparatus is combined with a container, and wherein said funnel is retentatively inserted into a wall of said container, and wherein said container is rested upon a support surface, and wherein said ramp member provides a bridge between said funnel and said support surface such that a pest may crawl from said support surface along said ramp member and into said funnel.

17. The apparatus of claim **10**, wherein said apparatus is combined with a container and wherein said funnel is retentatively inserted into a wall of said container, and wherein said apparatus is further secured to said container by at least one of an elastomeric band and a layer of adhesive, and wherein said container defines a plastic bottle container, and wherein said container contains an odor generating attractant within said container, and wherein said container includes a light within said container, and wherein said container includes an eyelet from which said container may be suspended.

13

18. An insertable pest trapping apparatus for inserting into a container to trap pests inside of a container, said apparatus comprising:

a substantially conical shaped hollow member having a first end and a second end which define a longitudinal axis of said substantially conical shaped hollow member therebetween, said first end having a first wide opening and said substantially conical shaped hollow member having a second narrow opening;

a flange attached to said first end of said substantially conical shaped hollow member, said flange being curved such that said flange forms a portion of a cylindrical wall, and wherein an axis of said cylindrical wall portion is substantially perpendicular to said axis of said substantially conical shaped hollow member and extends through said substantially conical shaped hollow member; and

at least one retention member extending from an external surface of said substantially conical shaped hollow member, said at least one retention member being configured so as to secure said apparatus to a container when said apparatus is at least partially inserted into a container wall.

19. The apparatus of claim 18, wherein said second narrow opening forms an opening at said second end of said substantially conical shaped hollow member.

20. An insertable pest trapping apparatus for inserting into a container in order to trap pests inside a container, said apparatus comprising:

a hollow member having a first end and a second end which define a longitudinal axis of said hollow member therebetween;

a flange attached to said first end of said hollow member, said flange being curved such that said flange forms a portion of a cylindrical wall, and wherein an axis of said cylindrical wall portion is substantially perpendicular to said axis of said hollow member and extends through said hollow member, said flange having at least one access hole formed within said flange;

at least one retention member extending from said flange, said at least one retention member being configured so as to secure said flange to a container when said apparatus is at least partially inserted into a container wall; and

a ramp extending from said flange, said ramp being configured such that when said apparatus is retentively inserted into a wall of a container and said container is rested upon a support surface, said ramp provides a bridge between said flange and said support surface such that a pest may crawl from said support surface along said ramp and into said access hole.

21. An insertable pest trapping apparatus for inserting into a container in order to trap pests inside a container, said apparatus comprising:

a funnel having a first end and a second end, said first end having a wide opening and said second end having a narrow opening;

a flange attached to said first end of said funnel, said flange being curved such that said flange forms a portion of a cylindrical wall, and wherein an axis of said cylindrical wall portion is substantially perpendicular to said axis of said funnel and extends through said funnel; and

14

at least one retention member extending from an external surface of said funnel, said at least one retention member being configured so as to secure said funnel to a container when said apparatus is at least partially inserted into a container wall; and wherein said apparatus is combined with a container, and wherein said apparatus is retentively inserted into a wall of said container.

22. The apparatus of claim 21, wherein said apparatus further includes at least one member of the following group of members connected to said apparatus, said group of members comprising an attractant support member, a blade member, and a ramp member.

23. The apparatus of claim 22, wherein said container is rested upon a support surface, and wherein said ramp member provides a bridge between said funnel and said support surface such that a pest may crawl from said support surface along said ramp member and into said funnel.

24. The apparatus of claim 21, wherein said apparatus is further secured to said container by at least one of an elastomeric band and a layer of adhesive, and wherein said container defines a plastic bottle container, and wherein said container contains an odor generating attractant within said container, and wherein said container includes a light emanating from within said container, and wherein said container includes an eyelet from which said container may be suspended.

25. An insertable pest trapping apparatus for inserting into a container in order to trap pests inside a container, said apparatus comprising:

a funnel having a first end and a second end which define a longitudinal axis of said funnel therebetween, said first end having a wide opening and said second end having a narrow opening;

a flange attached to said first end of said funnel, said flange being curved such that said flange forms a portion of a cylindrical wall, and wherein an axis of said cylindrical wall portion is substantially perpendicular to said axis of said funnel and extends through said funnel; and

at least one retention member extending from an external surface of said funnel, said at least one retention member being configured so as to secure said funnel to a container when said apparatus is at least partially inserted into a container wall; and wherein said apparatus includes at least one member of the following group of members connected to said apparatus, said group of members comprising an attractant support member, a blade member, and a ramp member, and wherein said apparatus is combined with a container, and wherein said apparatus is retentively inserted into a wall of said container, and wherein said container is rested upon a support surface, and wherein said ramp member provides a bridge between said funnel and said support surface such that a pest may crawl from said support surface along said ramp member and into said funnel, and wherein said apparatus is further secured to said container by at least one of an elastomeric band and a layer of adhesive, and wherein said container defines a plastic bottle container, and wherein said container contains an odor generating attractant within said container, and wherein said container includes a light within said container, and wherein said container includes an eyelet from which said container may be suspended.

UNITED STATES PATENT AND TRADEMARK OFFICE
CERTIFICATE OF CORRECTION

PATENT NO. : 7,503,142 B1
APPLICATION NO. : 11/688204
DATED : March 17, 2009
INVENTOR(S) : Michael A. Uhl

Page 1 of 1

It is certified that error appears in the above-identified patent and that said Letters Patent is hereby corrected as shown below:

On the title page, item [74] after the heading and words "Primary Examiner - Darren W Ark", the patent should include the following heading and name, "Attorney, Agent, or Firm - Michael R. Schramm".

Signed and Sealed this

Twenty-first Day of April, 2009



JOHN DOLL

Acting Director of the United States Patent and Trademark Office