

US007469085B1

(12) **United States Patent**
Vlasov

(10) **Patent No.:** **US 7,469,085 B1**
(45) **Date of Patent:** **Dec. 23, 2008**

(54) **METHOD AND APPARATUS FOR
MINIMIZING PROPAGATION LOSSES IN
WAVELENGTH SELECTIVE FILTERS**

(75) Inventor: **Yurii A. Vlasov**, Katonah, NY (US)

(73) Assignee: **International Business Machines
Corporation**, Armonk, NY (US)

(*) Notice: Subject to any disclaimer, the term of this patent is extended or adjusted under 35 U.S.C. 154(b) by 0 days.

(21) Appl. No.: **11/777,023**

(22) Filed: **Jul. 12, 2007**

(51) **Int. Cl.**
G02B 6/26 (2006.01)
G02B 6/42 (2006.01)

(52) **U.S. Cl.** **385/50; 385/15; 385/30**

(58) **Field of Classification Search** **385/14, 385/15, 27, 30, 50**

See application file for complete search history.

(56) **References Cited**

U.S. PATENT DOCUMENTS

5,446,573 A * 8/1995 Lomashevitch et al. 398/175
6,665,476 B2 * 12/2003 Braun et al. 385/50
6,818,468 B2 * 11/2004 Morse 438/49

6,947,642 B2 * 9/2005 Yamazaki 385/39
7,031,563 B2 * 4/2006 Block et al. 385/15
7,231,123 B2 * 6/2007 Sugita et al. 385/129
2005/0213873 A1 9/2005 Piede et al. 385/14
2008/0089367 A1 * 4/2008 Srinivasan et al. 372/19

OTHER PUBLICATIONS

Tishinin et al, "Vertical Resonant Couplers with Precise Coupling Efficiency Control Fabricated by Wafer Bonding," IEEE Photonics Technology Letters, vol. 11, No. 8, Aug. 1999.*

Tishinin, et al, "Vertical Resonant Couplers with Precise Coupling Efficiency Control Fabricated by Wafer Bonding," IEEE Photonics Technology Letters, vol. 11, No. 8, Aug. 1999.

* cited by examiner

Primary Examiner—Sung Pak

Assistant Examiner—Daniel Petkovsek

(57) **ABSTRACT**

The present invention is a method and an apparatus for minimizing losses in wavelength selective filters. In one embodiment, an apparatus includes a waveguide bus defined in a first crystalline layer of the apparatus, for receiving incoming light, a resonator defined in the first crystalline layer, and a coupling structure defined in a second polysilicon or amorphous silicon layer of the apparatus, for coupling a selected wavelength of the incoming light from the waveguide bus to the resonator.

2 Claims, 3 Drawing Sheets

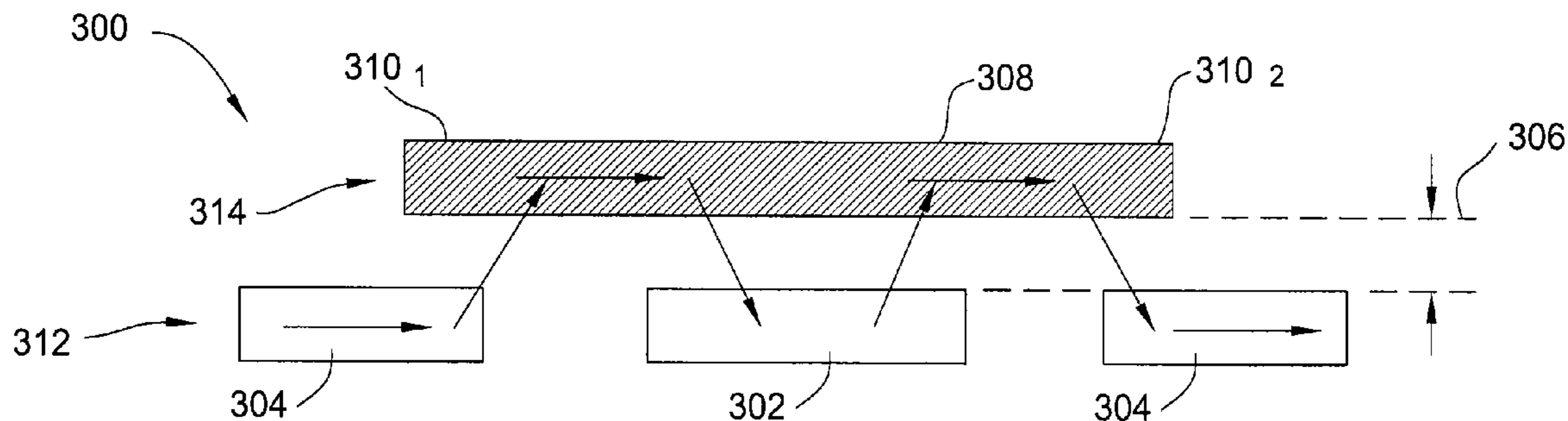

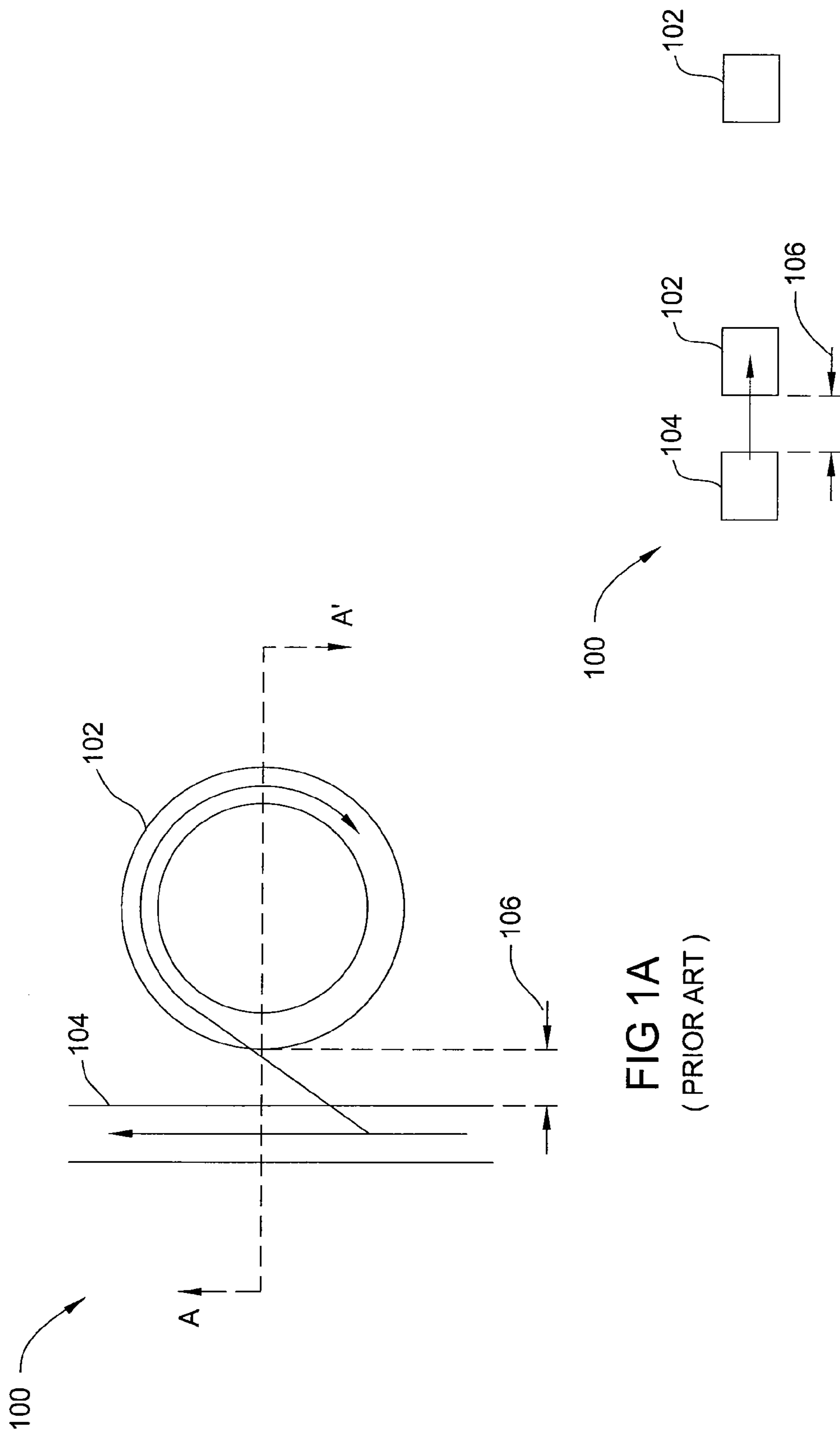

FIG 1A
(PRIOR ART)

FIG 1B

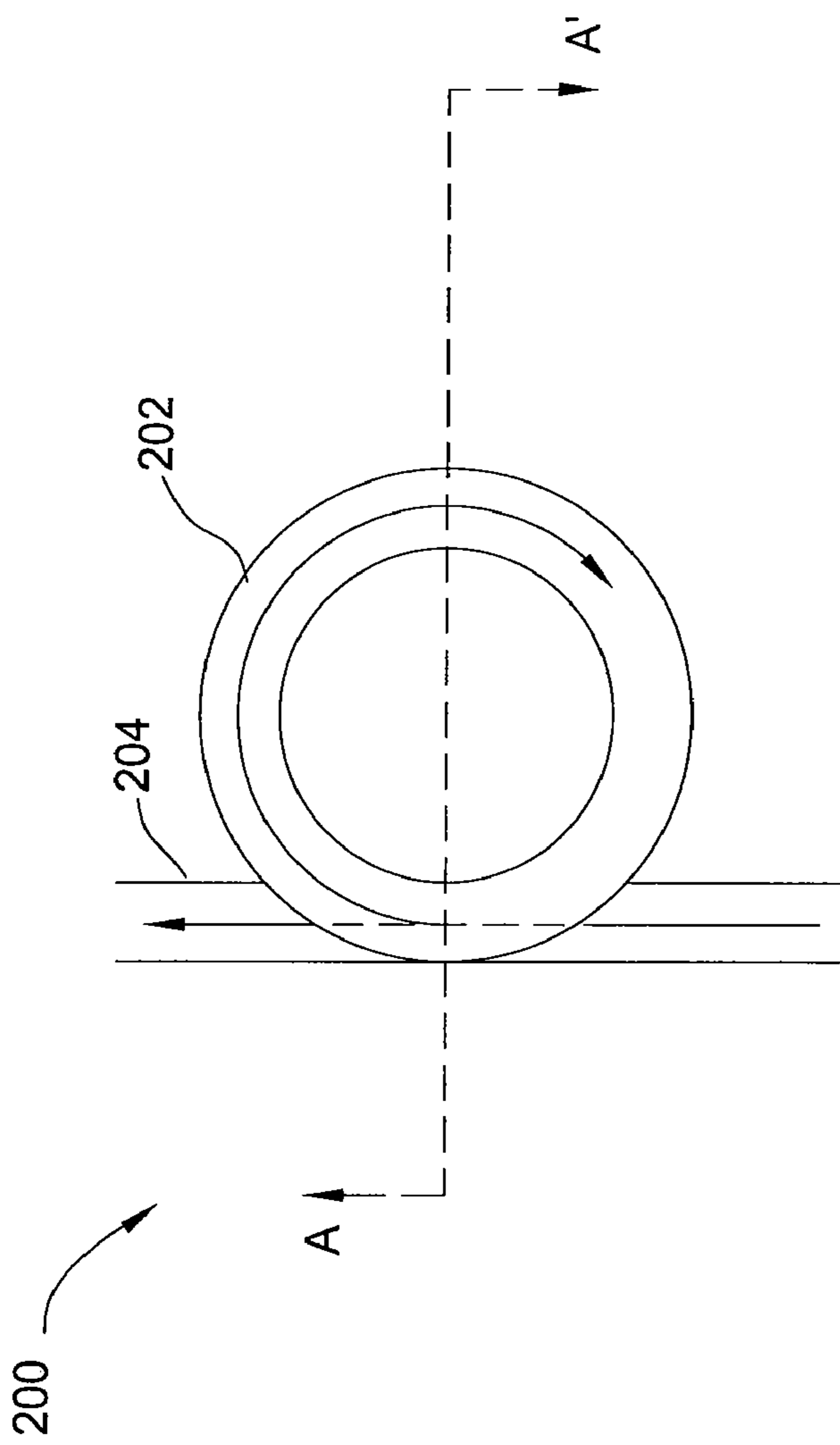

FIG 2A
(PRIOR ART)

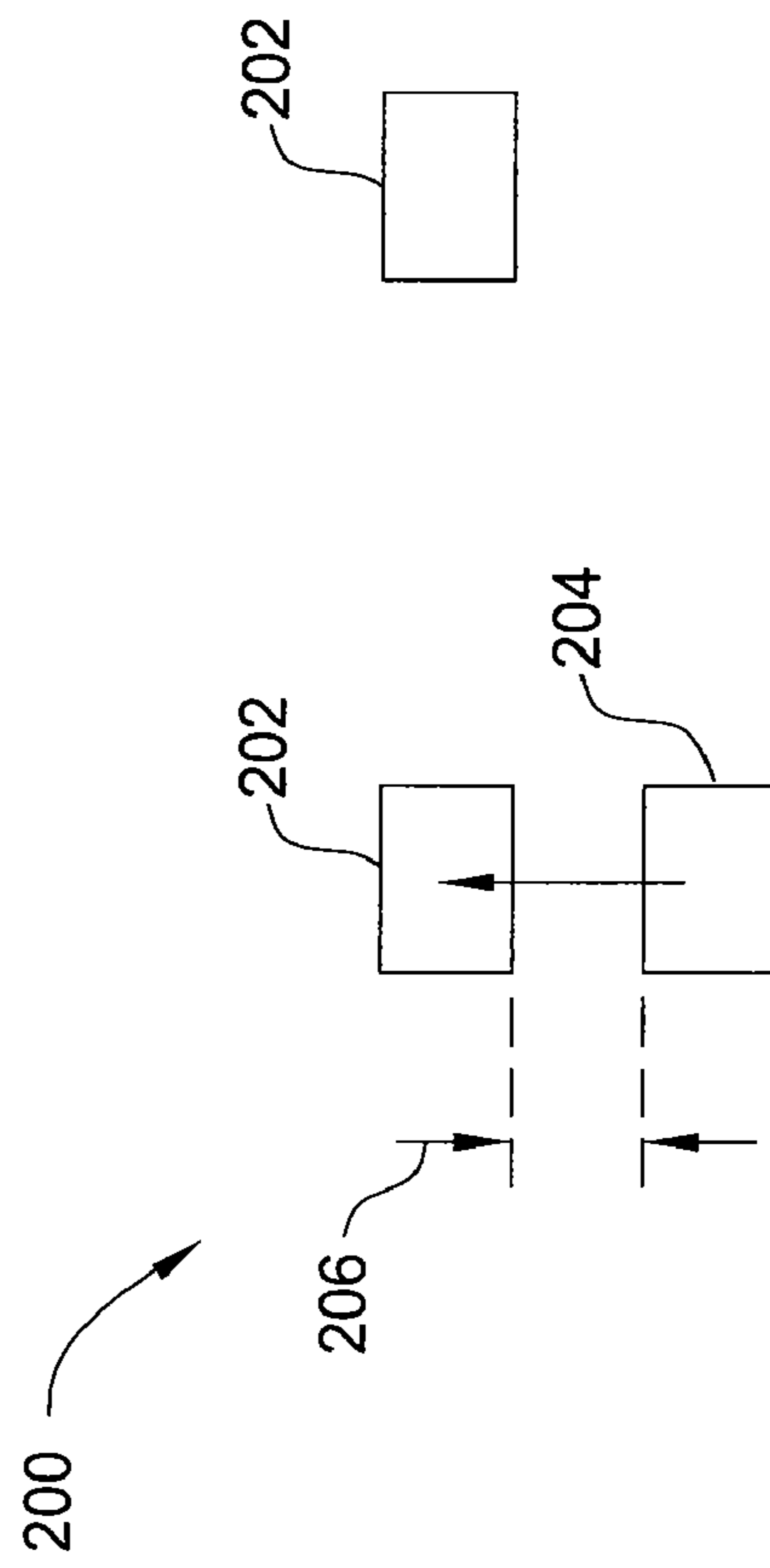
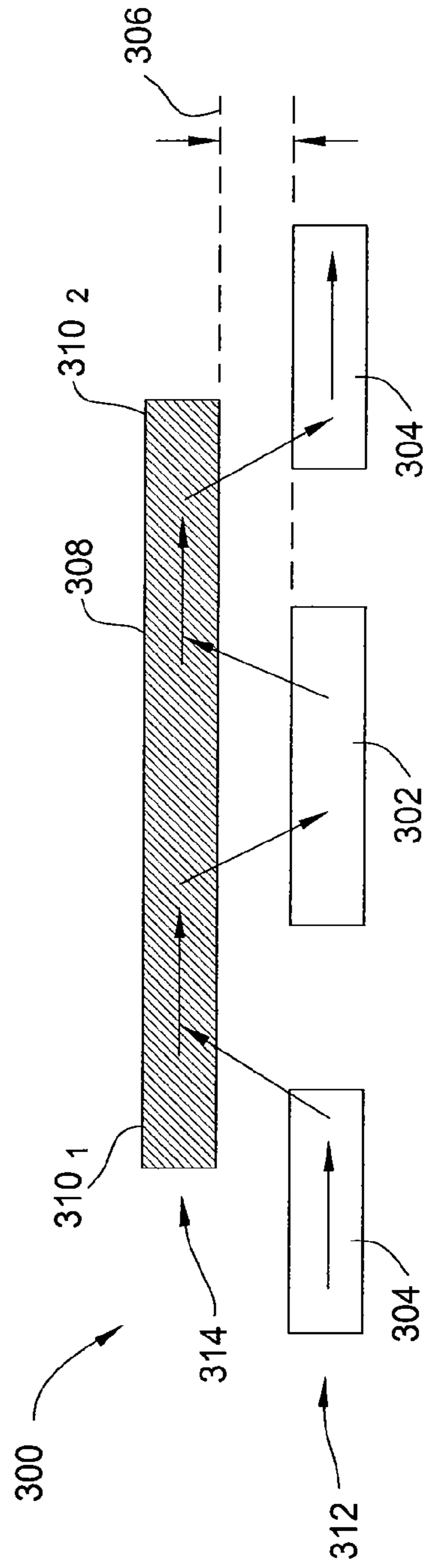
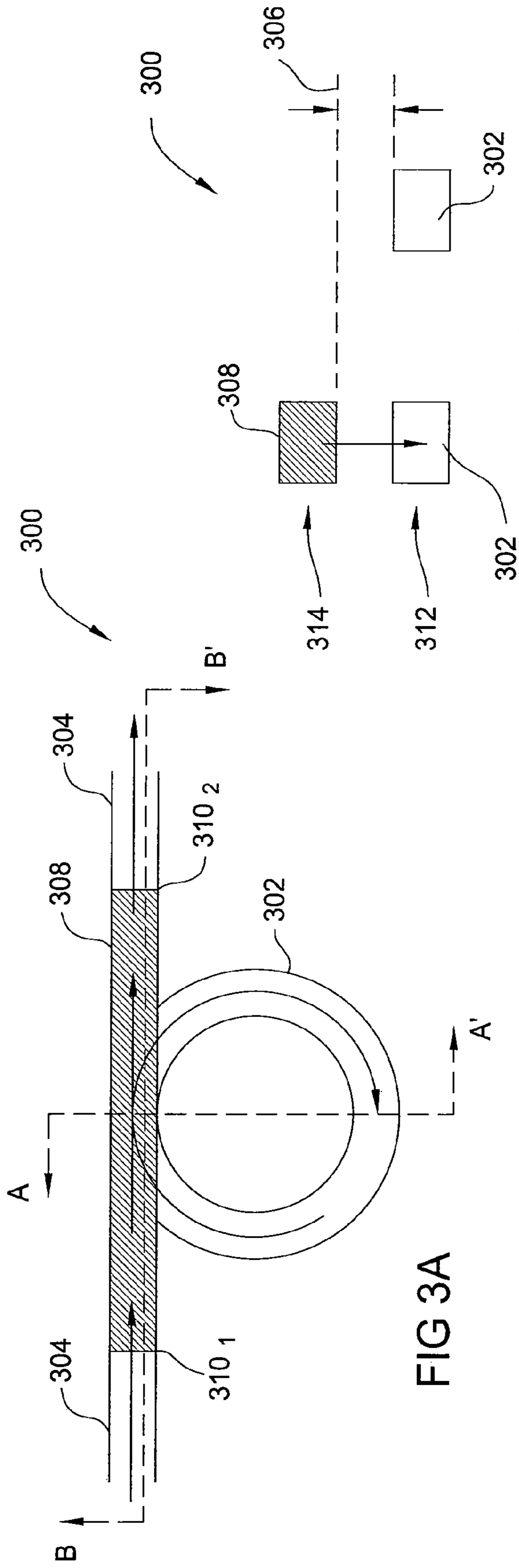

FIG 2B



1

**METHOD AND APPARATUS FOR
MINIMIZING PROPAGATION LOSSES IN
WAVELENGTH SELECTIVE FILTERS**

BACKGROUND

The invention relates generally to optics, and relates more particularly to optical interconnects.

FIG. 1A illustrates a top view of one example of a conventional wavelength selective filter **100** (e.g., such as those used for wavelength division multiplexing). FIG. 1B illustrates a cross sectional view of the filter **100** of FIG. 1A, taken along line A-A'. The filter **100** includes a ring resonator **102** side-coupled to an access straight waveguide (or waveguide bus) **104**. The ring resonator **102** is tuned to a wavelength channel of interest, such that the ring resonator **102** filters this channel from the bus **104**. For high refractive index contrast planar lightwave waveguides and circuits, the coupling gap **106** (i.e., the distance that separates the ring resonator **102** from the bus **104**) is typically on the order of a micrometer and controlled within a few nanometers of precision. Such control, however, is difficult to achieve by typical lithography methods.

FIG. 2A illustrates a top view of an alternative example of a conventional wavelength selective filter **200**. FIG. 2B illustrates a cross sectional view of the filter **200** of FIG. 2A, taken along line A-A'. Like the filter **100**, the filter **200** includes a ring resonator **202** coupled to a waveguide bus **204**. However, as illustrated in FIG. 2B, the ring resonator **202** is formed in a high refractive index waveguiding layer that is separate from the layer in which the bus **204** is formed. In this case, the coupling gap **206** is vertically disposed and can be precisely controlled by an amount of gap material grown, for example, by molecular-beam epitaxy (MBE).

For silicon on insulator (SOI)-based planar lightwave circuits based on strip silicon single-mode waveguides with sub-micron cross sections, the approach illustrated in FIGS. 1A and 1B results in a coupling gap on the order of 100 nanometers, which should be controlled with nanometer precision. This makes fabrication tolerances very difficult to maintain. Applying the alternative approach illustrated in FIGS. 2A and 2B would require the growth of an oxide or other low refractive index material on top of the SOI structure to form the coupling gap, followed by growth of an additional top silicon layer for the ring resonator. This is likely to result in a polycrystalline or amorphous silicon structure on top of the silicon layer, which can lead to significant propagation losses (e.g., approximately twenty dB/cm) due to scattering on the grain boundaries. Losses are increased proportionally to the photon lifetime (inverse of the ring resonator quality factor) if the ring resonator or other resonator structure is located on the top layer of the circuit.

Thus, there is a need for a method and an apparatus for minimizing propagation losses in wavelength selective filters.

SUMMARY OF THE INVENTION

The present invention is a method and an apparatus for minimizing losses in wavelength selective filters. In one embodiment, an apparatus includes a waveguide bus defined in a first crystalline layer of the apparatus, for receiving incoming light, a resonator defined in the first crystalline layer, and a coupling structure defined in a second polysilicon or amorphous silicon layer of the apparatus, for coupling a selected wavelength of the incoming light from the waveguide bus to the resonator.

2

BRIEF DESCRIPTION OF THE DRAWINGS

So that the manner in which the above recited embodiments of the invention are attained and can be understood in detail, a more particular description of the invention, briefly summarized above, may be obtained by reference to the embodiments thereof which are illustrated in the appended drawings. It is to be noted, however, that the appended drawings illustrate only typical embodiments of this invention and are therefore not to be considered limiting of its scope, for the invention may admit to other equally effective embodiments.

FIG. 1A illustrates a top view of one example of a conventional wavelength selective filter;

FIG. 1B illustrates a cross sectional view of the filter of FIG. 1A, taken along line A-A';

FIG. 2A illustrates a top view of an alternative example of a conventional wavelength selective filter;

FIG. 2B illustrates a cross sectional view of the filter of FIG. 2A, taken along line A-A';

FIG. 3A is a top view of one embodiment of a wavelength selective filter, according to the present invention;

FIG. 3B is a cross sectional view of the filter of FIG. 3A, taken along line A-A'; and

FIG. 3C is a cross sectional view of the filter of FIG. 3A taken along line B-B'.

To facilitate understanding, identical reference numerals have been used, where possible, to designate identical elements that are common to the figures.

DETAILED DESCRIPTION

In one embodiment, the present invention is a method and an apparatus for minimizing propagation losses in wavelength selective filters. Embodiments of the present invention vertically couple a waveguide bus to a resonator using a straight polysilicon waveguide section with lateral tapers, where the waveguide bus and the resonator are located on a common crystalline layer of an SOI wafer.

FIG. 3A is a top view of one embodiment of a wavelength selective filter **300**, according to the present invention. FIG. 3B is a cross sectional view of the filter **300** of FIG. 3A, taken along line A-A'. FIG. 3C is a cross sectional view of the filter **300** of FIG. 3A taken along line B-B'. Referring simultaneously to FIGS. 3A-3C, the filter **300** comprises a resonator (e.g., a ring resonator) **302**, a waveguide bus **304** and a coupling structure **308**.

The resonator **302** and the waveguide bus **304** are defined in a first, common crystalline layer **312** of the SOI wafer of the filter **300**. The coupling structure **308** is defined in a second layer **314** of the filter **300**, located in one embodiment above the first layer **312**. In one embodiment, the second layer comprises polysilicon or amorphous silicon. The coupling structure **308** comprises a substantially straight waveguide having lateral adiabatic tapers **310₁-310₂** (hereinafter collectively referred to as "tapers **310**") at each end. The tapers **310** are configured for coupling incoming light between the coupling structure **308** and the waveguide bus **304** or the resonator **302**.

Specifically, incoming light is received in the first layer **312** of the filter **300** by a first section of the waveguide bus **304**. As the light propagates through the waveguide bus **304**, it is coupled to the coupling structure **308** in the second layer **314** of the filter **300**, via a first taper **310₁**. The light then propagates through the coupling structure **308** until the light reaches the resonator **302**, where the selected wavelength is coupled to the resonator **302**. The remainder of the light (i.e., wavelengths other than the selected wavelength) continues to

3

propagate along the coupling structure **308** until the light reaches a second taper **310**, by which the remainder of the light is coupled back to the waveguide bus **304**.

The filter **300** is thereby configured to control the coupling gap **306** between the resonator **302** and the waveguide bus **304** by growth (e.g., of oxide or other low refractive index material). However, propagation losses in this case are minimized because the optical mode of incoming light propagates in the polysilicon or amorphous silicon top layer (i.e., second layer **314**) for only a very short relative distance, and no further substantial losses due to the resonator **302** occur.

Thus, the present invention represents a significant advancement in the field of optics. Embodiments of the present invention provide a coupling section (e.g., a straight poly-silicon waveguide section with lateral tapers) by which a waveguide bus is vertically coupled to a resonator. The gap between the bus and the resonator can be tightly controlled, while propagation losses are minimized.

While foregoing is directed to the preferred embodiment of the present invention, other and further embodiments of the invention may be devised without departing from the basic scope thereof, and the scope thereof is determined by the claims that follow.

The invention claimed is:

1. A method for filtering light of a selected wavelength from incoming light, comprising:

4

receiving the incoming light via a waveguide bus located in a first crystalline layer of a wavelength selective filter; coupling the light from the waveguide bus to a coupling structure located in a second layer of the wavelength selective filter; and

coupling light of the selected wavelength from the coupling structure to a resonator located in the first crystalline layer, wherein the coupling structure comprises:

at least one lateral, adiabatic taper for coupling the incoming light between the coupling structure and the waveguide bus or between the coupling structure and the resonator.

2. A method for filtering light of a selected wavelength from incoming light, comprising:

receiving the incoming light via a waveguide bus located in a first crystalline layer of a wavelength selective filter; coupling the light from the waveguide bus to a coupling structure located in a second layer of the wavelength selective filter;

coupling light of the selected wavelength from the coupling structure to a resonator located in the first crystalline layer, wherein a coupling gap is formed between the first crystalline layer and the second layer; and

controlling the coupling gap by oxide growth.

* * * * *