

U.S. PATENT DOCUMENTS

4,292,655 A 9/1981 Carasso et al.
 4,394,774 A 7/1983 Widergren et al.
 4,414,677 A * 11/1983 Ive et al. 375/366
 4,580,162 A 4/1986 Mori
 4,680,766 A 7/1987 Wilkinson
 4,827,339 A 5/1989 Wada et al.
 4,985,766 A 1/1991 Morrison et al.
 4,985,768 A 1/1991 Sugiyama
 5,117,427 A 5/1992 Miyake et al.
 5,121,205 A 6/1992 Ng et al.
 5,168,356 A 12/1992 Acampora et al.
 5,208,816 A 5/1993 Seshardi et al.
 5,218,622 A 6/1993 Fazel et al.
 5,220,325 A 6/1993 Ackland et al.
 5,228,028 A * 7/1993 Cucchi et al. 370/392
 5,247,357 A 9/1993 Israelsen
 5,260,783 A * 11/1993 Dixit 375/240.13
 5,285,497 A 2/1994 Thatcher, Jr.
 5,313,203 A 5/1994 Suu et al.
 5,321,440 A 6/1994 Yanagihara et al.
 5,355,379 A 10/1994 Hobson et al.
 5,379,116 A 1/1995 Wada et al.
 5,386,233 A 1/1995 Keith
 5,412,484 A 5/1995 Yoshikawa
 5,416,787 A 5/1995 Kodama et al.
 5,420,640 A 5/1995 Munich et al.
 5,440,345 A 8/1995 Shimoda
 5,442,390 A * 8/1995 Hooper et al. 725/90
 5,444,490 A 8/1995 de With et al.
 5,446,839 A 8/1995 Dea et al.
 5,452,006 A 9/1995 Auld
 5,533,021 A * 7/1996 Branstad et al. 370/396
 5,546,399 A * 8/1996 Shimoda 370/474
 5,561,791 A * 10/1996 Mendelson et al. 709/233
 5,566,192 A 10/1996 Moon
 5,568,140 A 10/1996 Imanishi et al.
 5,570,132 A 10/1996 De With et al.
 5,592,518 A 1/1997 Davis et al.
 5,612,979 A 3/1997 Takano
 5,627,845 A 5/1997 Asano et al.
 5,668,810 A 9/1997 Cannella, Jr.
 5,745,504 A 4/1998 Bang
 5,757,416 A 5/1998 Birch et al.
 5,767,912 A 6/1998 Bunting et al.
 5,835,144 A 11/1998 Matsumura et al.
 5,862,153 A 1/1999 Kikuchi et al.
 5,884,269 A 3/1999 Cellier et al.
 6,014,171 A 1/2000 Koyanagi et al.
 6,571,361 B1 5/2003 Kikuchi et al.
 6,823,484 B2 11/2004 Kikuchi et al.
 6,918,080 B2 7/2005 Kikuchi et al.
 7,051,247 B2 5/2006 Kikuchi et al.
 2005/0229078 A1 10/2005 Kikuchi et al.
 2006/0206786 A1 9/2006 Kikuchi et al.
 2007/0061679 A1 3/2007 Kikuchi et al.
 2007/0094575 A1 4/2007 Kikuchi et al.
 2007/0094576 A1 4/2007 Kikuchi et al.
 2007/0094577 A1 4/2007 Kikuchi et al.
 2007/0094578 A1 4/2007 Kikuchi et al.

FOREIGN PATENT DOCUMENTS

EP 0 651 584 A2 5/1995
 JP 3-198432 8/1991
 JP 3-250935 11/1991
 JP 6-343065 12/1994

JP 7-38857 2/1995
 JP 7-235879 9/1995
 JP 63-73786 4/1998

OTHER PUBLICATIONS

Chujoh et al., "Error tolerant very low bitrate video coding (2)—Duplicate transmission for important information and reversible code," Annual Meeting of IEICE (1996), p. 12.
 Notification of Reason for Rejection issued by the Japanese Patent Office, dated Apr. 27, 2004, for Japanese Patent Application No. 8-243883, and English-language translation thereof.
 International Search Report mailed Jun. 17, 1997.
 Verbiest, W. et al., "A Variable Bit Rate Video Codec for Asynchronous Transfer Mode Networks", IEE Journal on Selected Areas in Communications, vol. 7, No. 5, Jun. 1989, pp. 761-770.
 Bae J. et al., "Survey of Traffic Control Schemes and Protocols in ATM Networks", Proceedings of the IEEE, vol. 79, No. 2, Feb. 1991, pp. 170-189.
 Kinoshita, T. et al., "Variable-Bit-Rate HDTV CODEC with ATM-Cell-Loss Compensation", IEEE Transactions on Circuits and Systems for Video Technology, vol. 3, No. 3, Jun. 1993, pp. 230-237.
 Ghanbari M. et al., "Packing Coded Video Signals into ATM Cells", IEEE/ACM Transactions on Networking, vol. 1, No. 5, Oct. 1993, pp. 505-509.
 Lei, S., "Forward Error Correction Codes for MPEG2 over ATM", IEEE Transactions on Circuits and Systems for Video Technology, vol. 4, No. 2, Apr. 1994, pp. 200-203.
 Akiyama, T. et al., "MPEG2 Video Codec using Image Compression DSP", IEEE Transactions on Consumer Electronics, vol. 40, No. 3, Aug. 1994, pp. 466-472.
 Takishima Y. et al., "Reversible Variable Length Codes", IEEE Transactions on Communications, vol. 43, No. 2/3/4, Feb./Mar./Apr. 1995, pp. 158-162.
 Aign, S. et al., "Temporal & Spatial Error Concealment Techniques for Hierarchical MPEG-2 Video Codec", ICC '95, Jun. 1995, pp. 1778-1783.
 Hanna, C. et al., "Demultiplexer IC for MPEG2 Transport Streams", IEEE Transactions on Consumer Electronics, vol. 41, No. 3, Aug. 1995, pp. 699-706.
 Aign, S., "Error Concealment Enhancement by Using the Reliability Outputs of SOVA in MPEG-2 Video Decoder", ISSSE '95, Oct. 1995, pp. 59-62.
 European Search Report dated Mar. 5, 2008 for European Patent Application 06023632.0—1237.
 European Search Report dated Mar. 5, 2008 for European Patent Application 06023631.2—1237.
 European Search Report dated Mar. 5, 2008 for European Patent Application 06023617.1—1237.
 European Search Report dated Mar. 5, 2008 for European Patent Application 06023616.3—1237.
 European Search Report dated Mar. 5, 2008 for European Patent Application 06023621.3—1237.
 European Search Report dated Mar. 5, 2008 for European Patent Application 06023634.6—1237.
 European Search Report dated Mar. 5, 2008 for European Patent Application 06023620.5—1237.
 European Search Report dated Mar. 5, 2008 for European Patent Application 06023630.4—1237.
 European Search Report dated Mar. 5, 2008 for European Patent Application 06023633.8—1237.
 European Search Report dated Mar. 5, 2008 for European Patent Application 06023629.6—1237.
 Section 1: Systems-Introduction XP 002034584, pp. 1-57, 1992.
 Wai-Man Lam, "Self-Synchronizing Variable-Length Codes For Image Transmission", pp. III-477-III-480, Mar. 23, 1992.

* cited by examiner

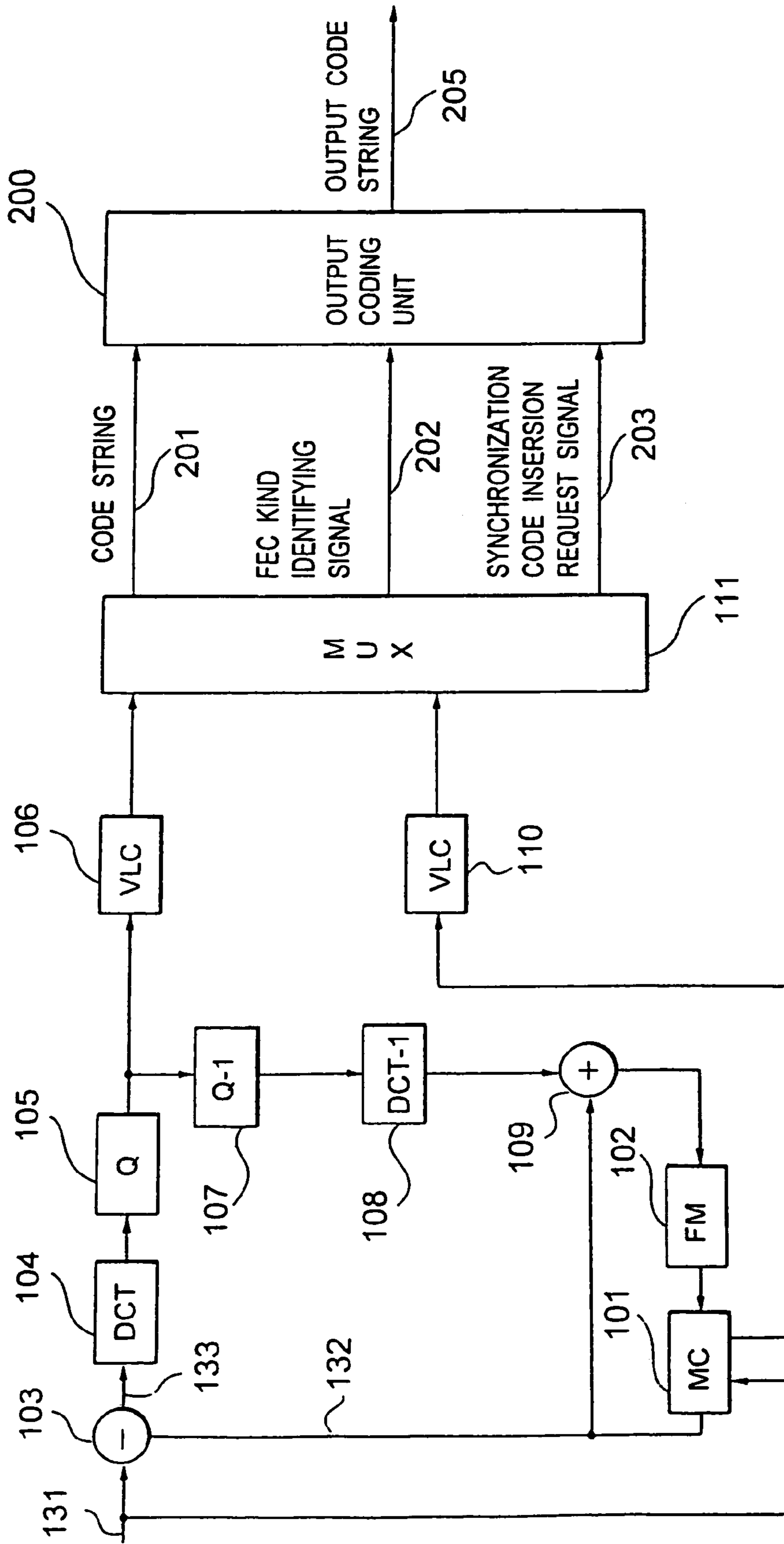

FIG. 1

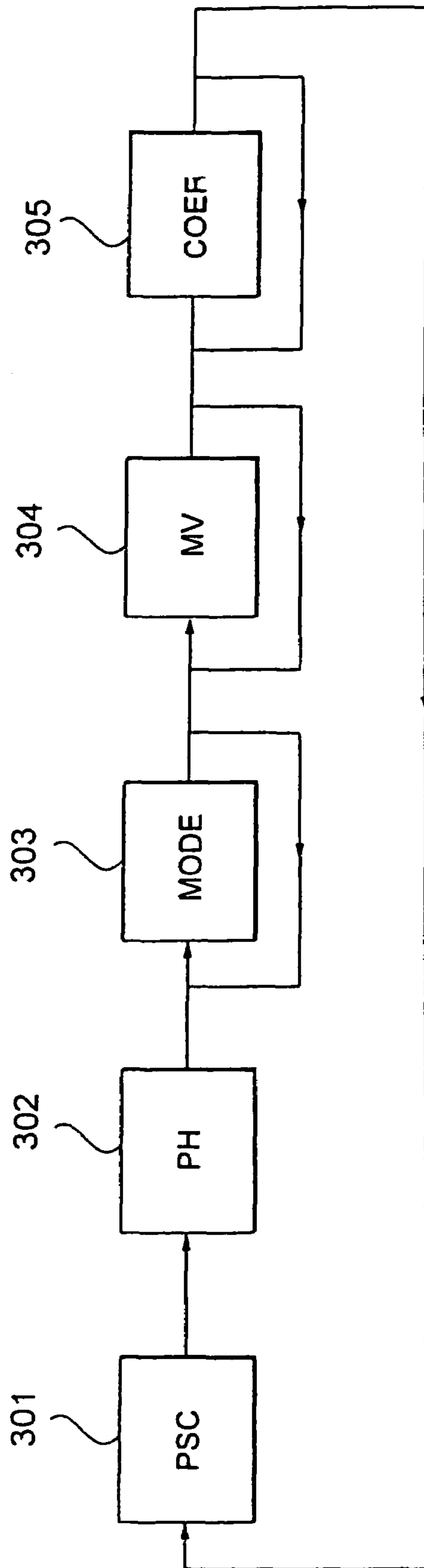

FIG. 2

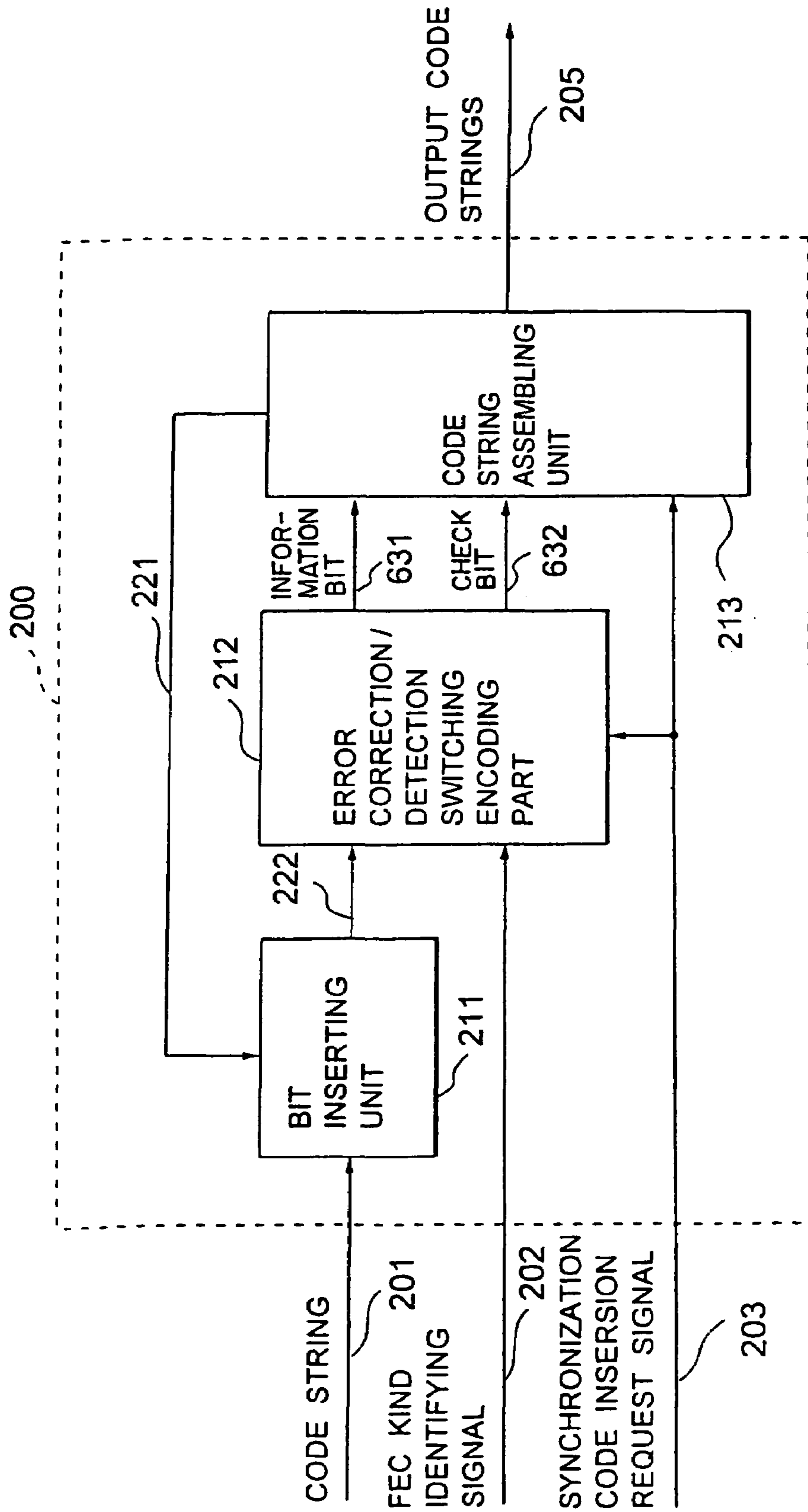

FIG. 3

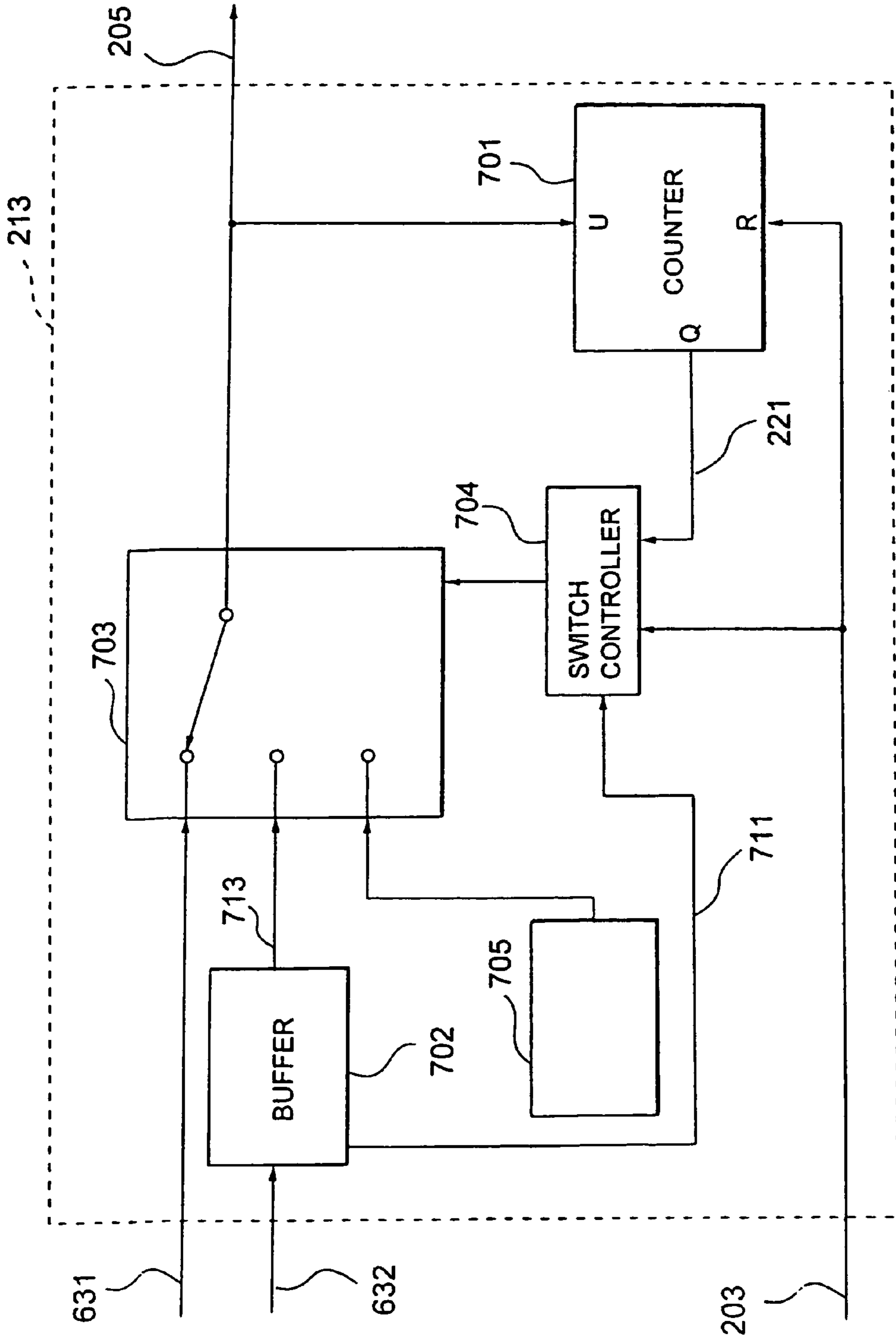

FIG. 7

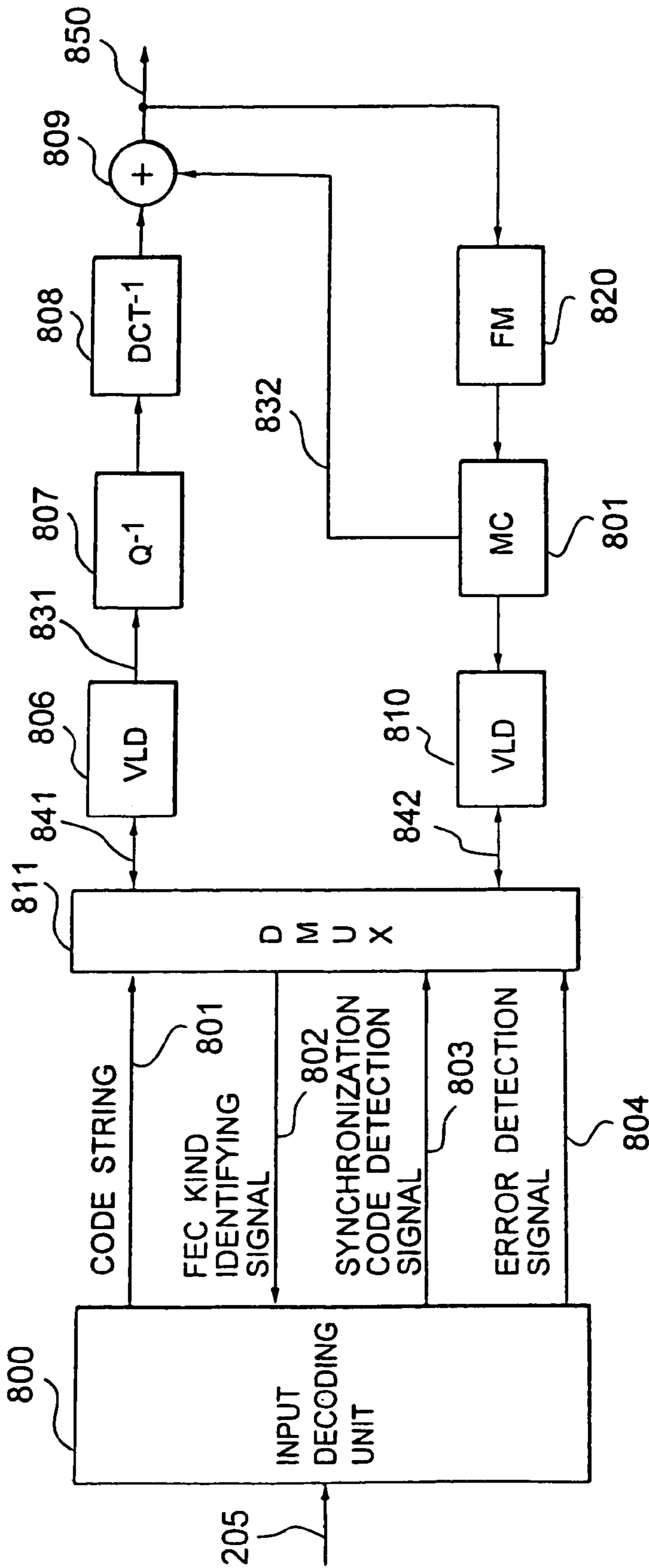

FIG. 8

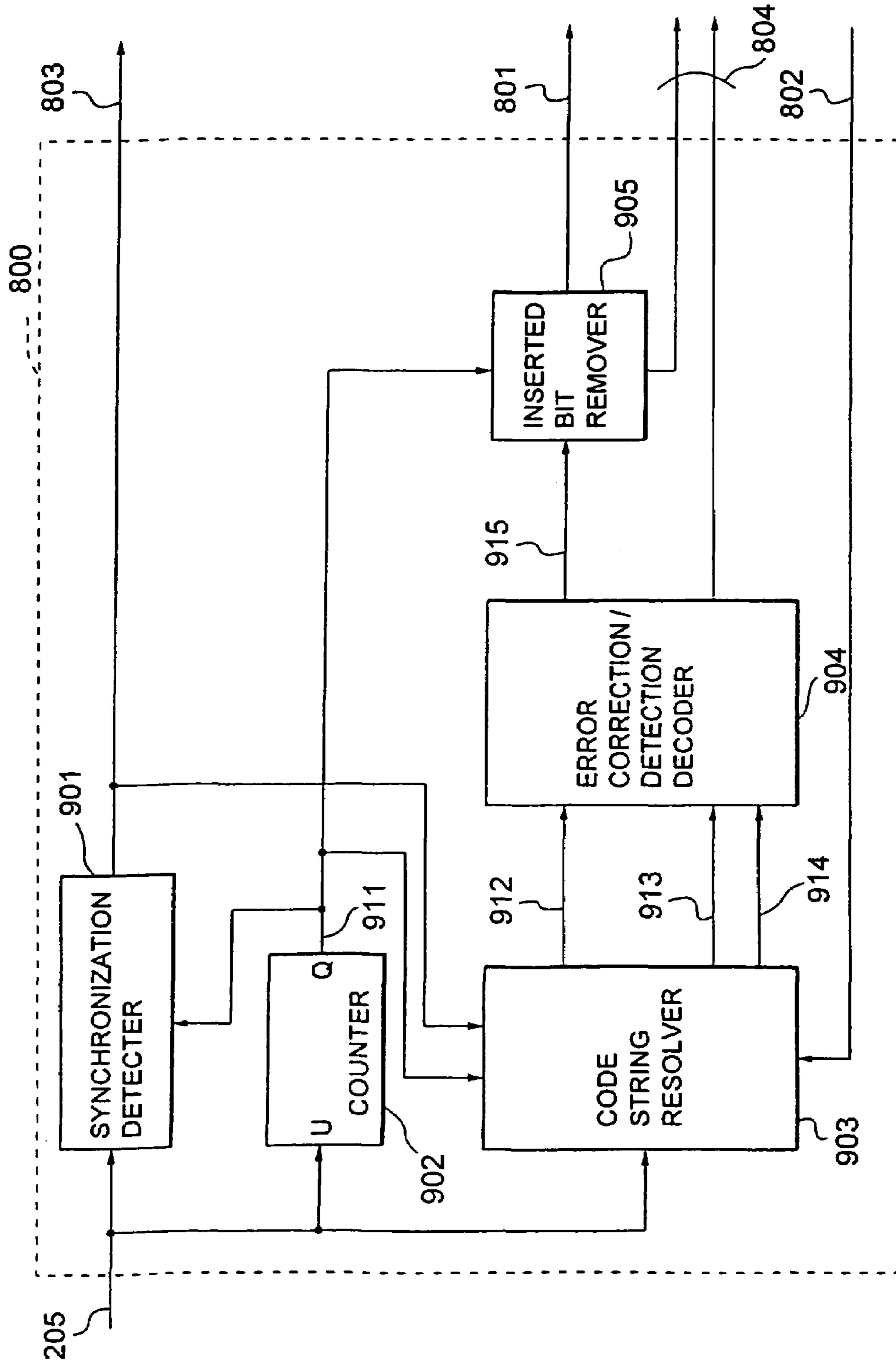

FIG. 9

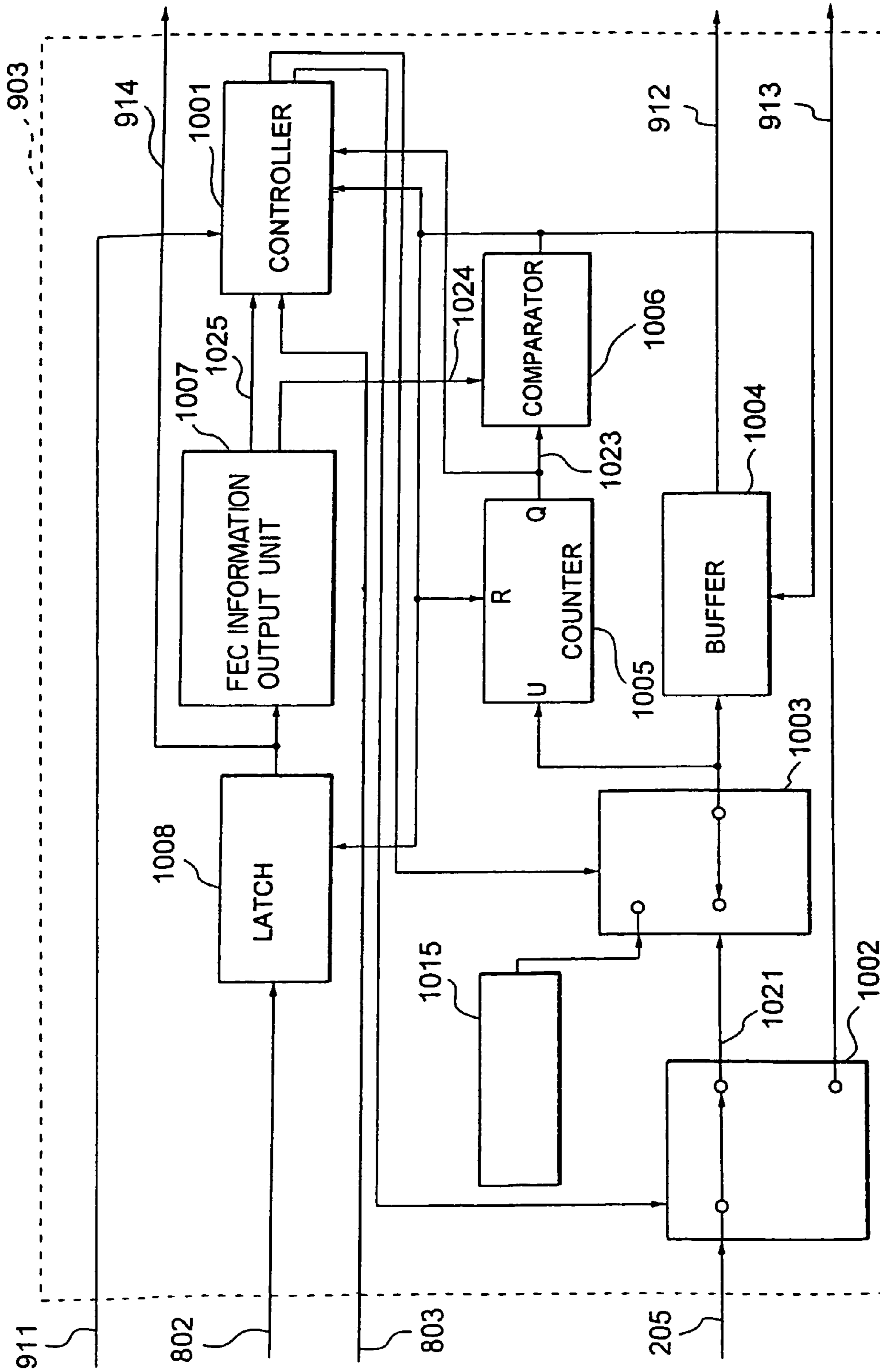

FIG. 10

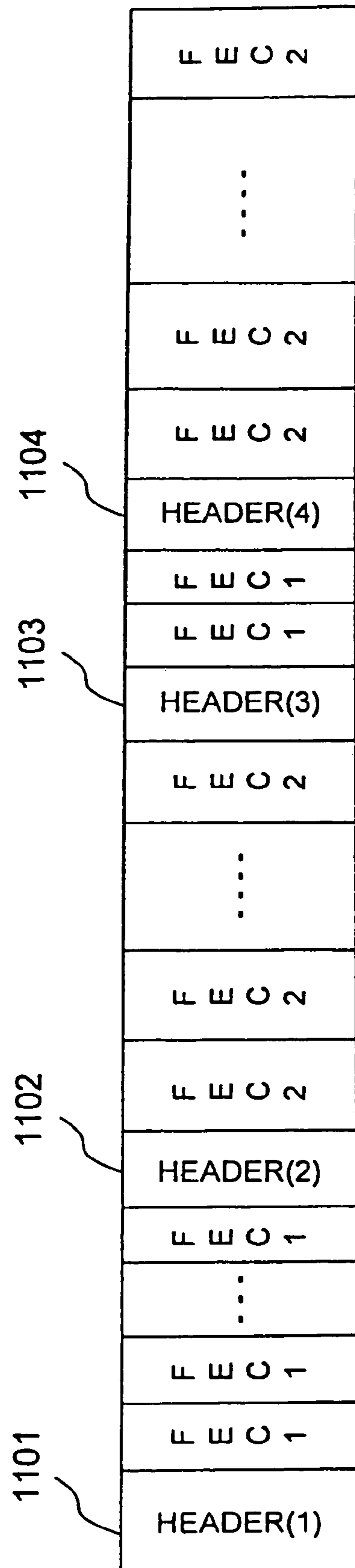
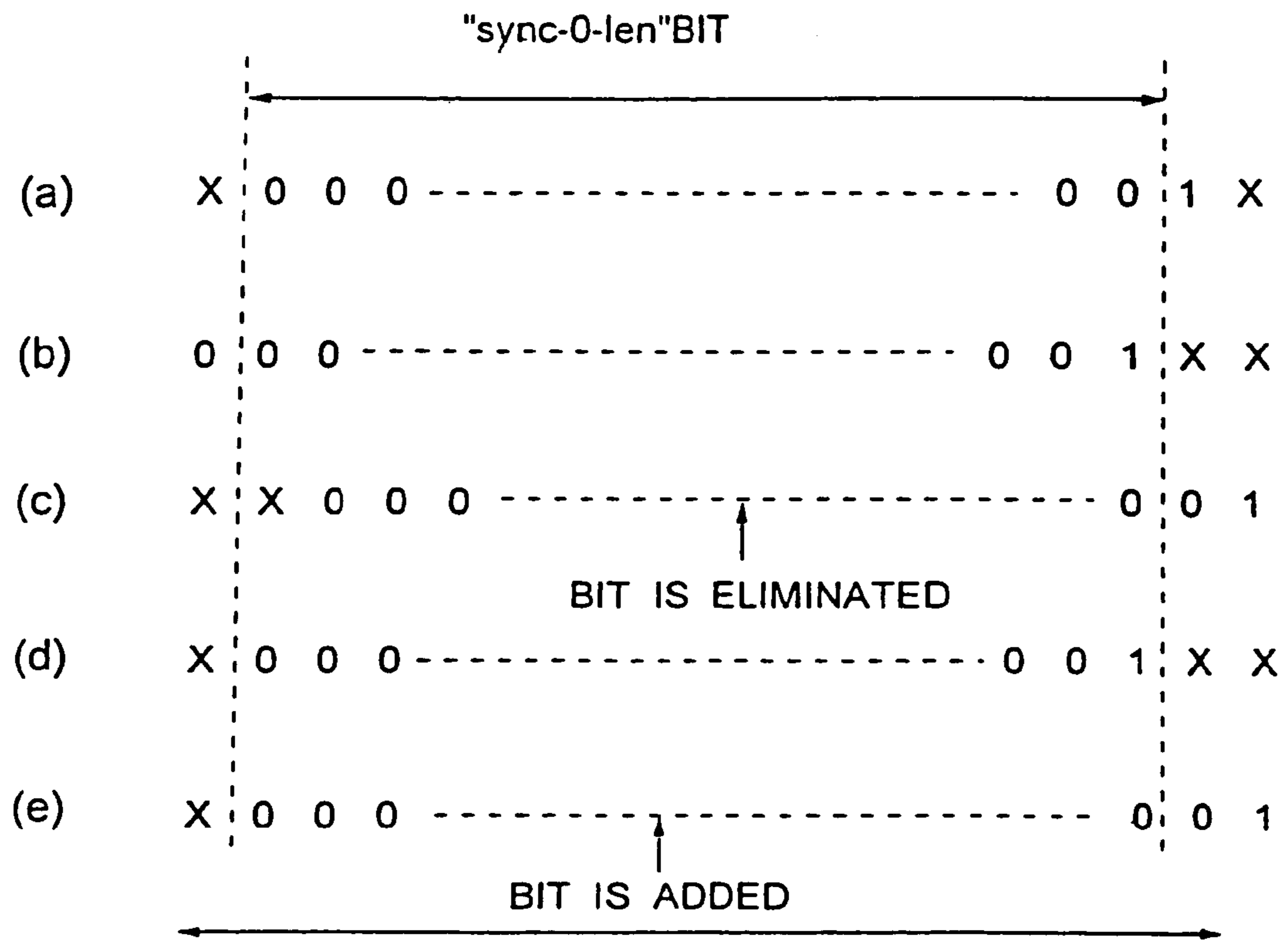

FIG. 11



SYNCHRONIZATION CODE DETECTION
 WINDOW OF "sync-0-len+2"BIT

FIG.12

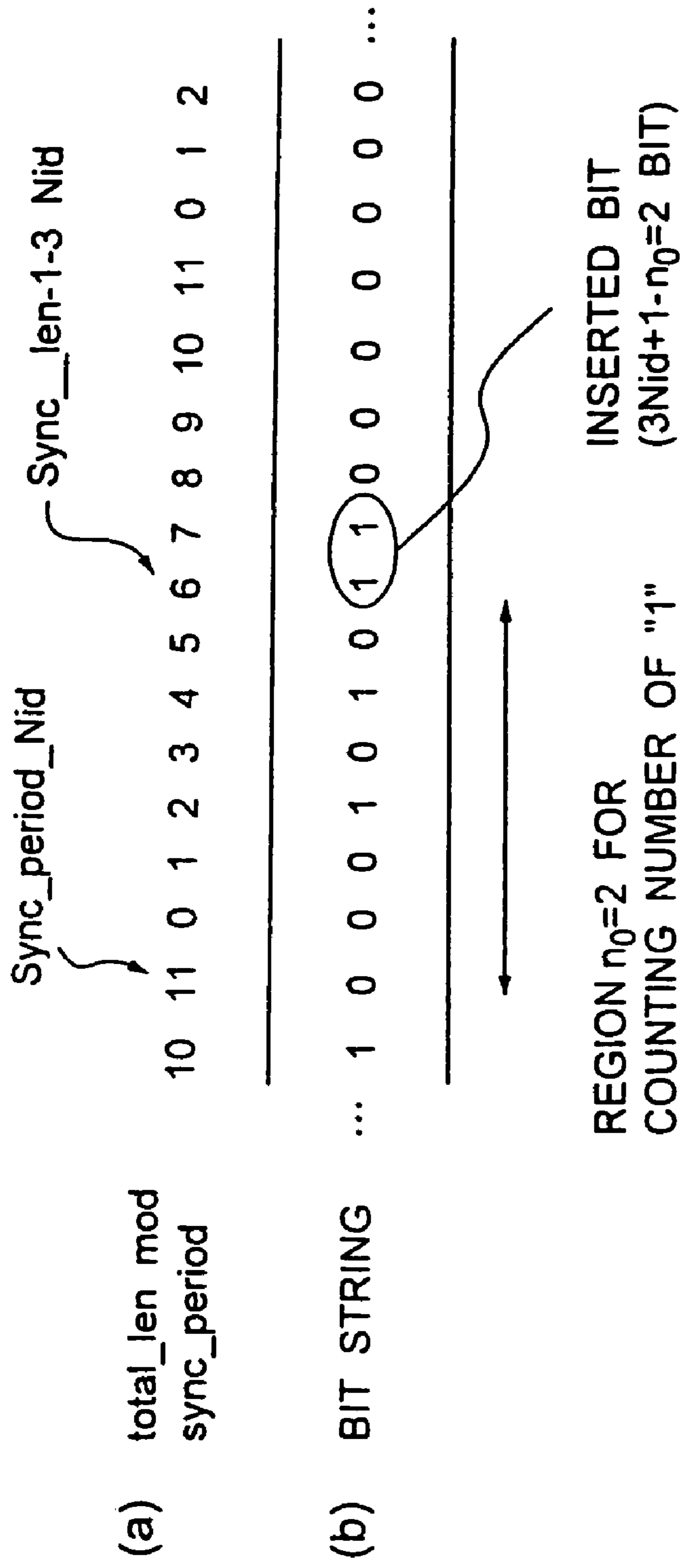

FIG. 13

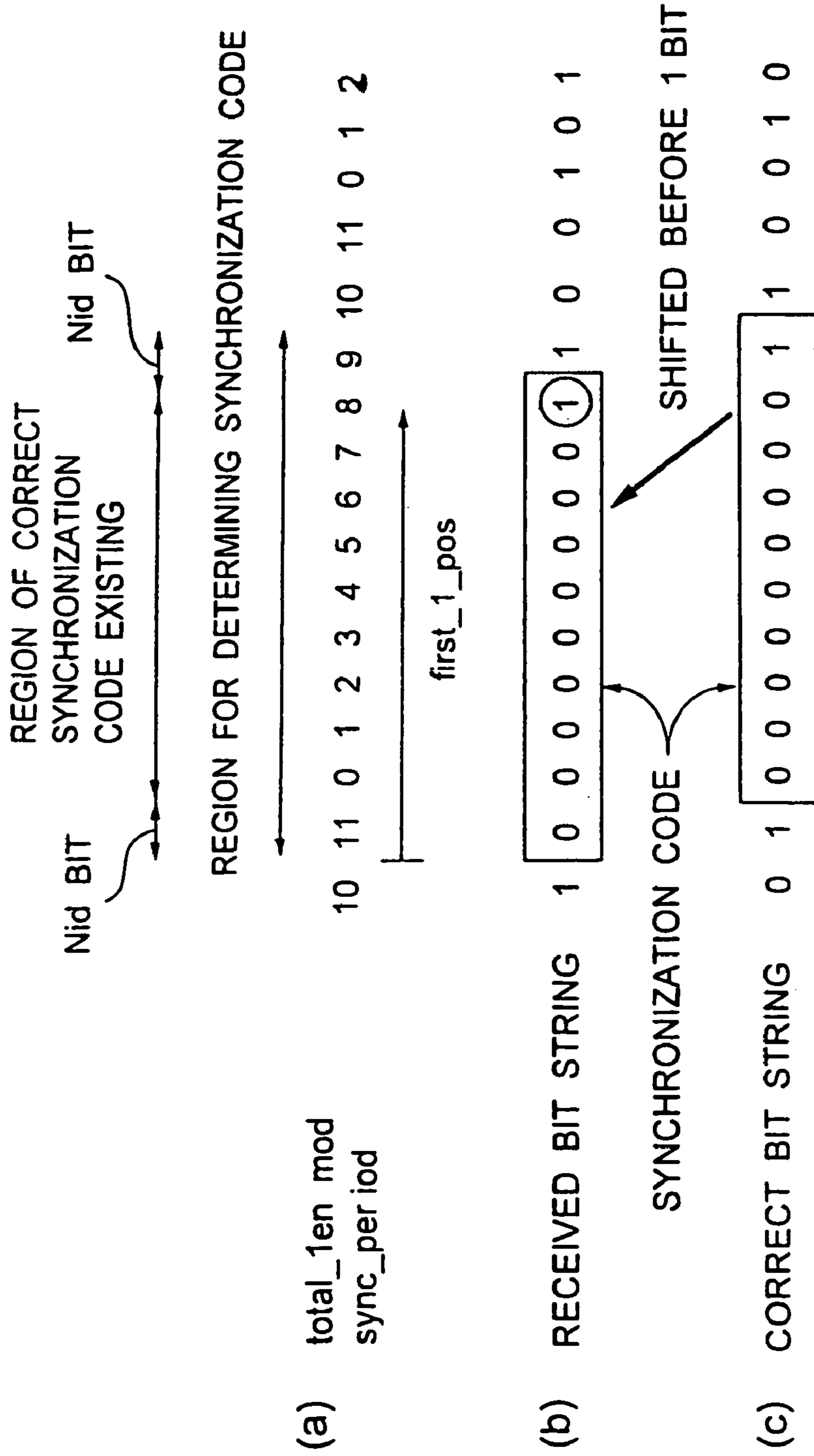

FIG. 14

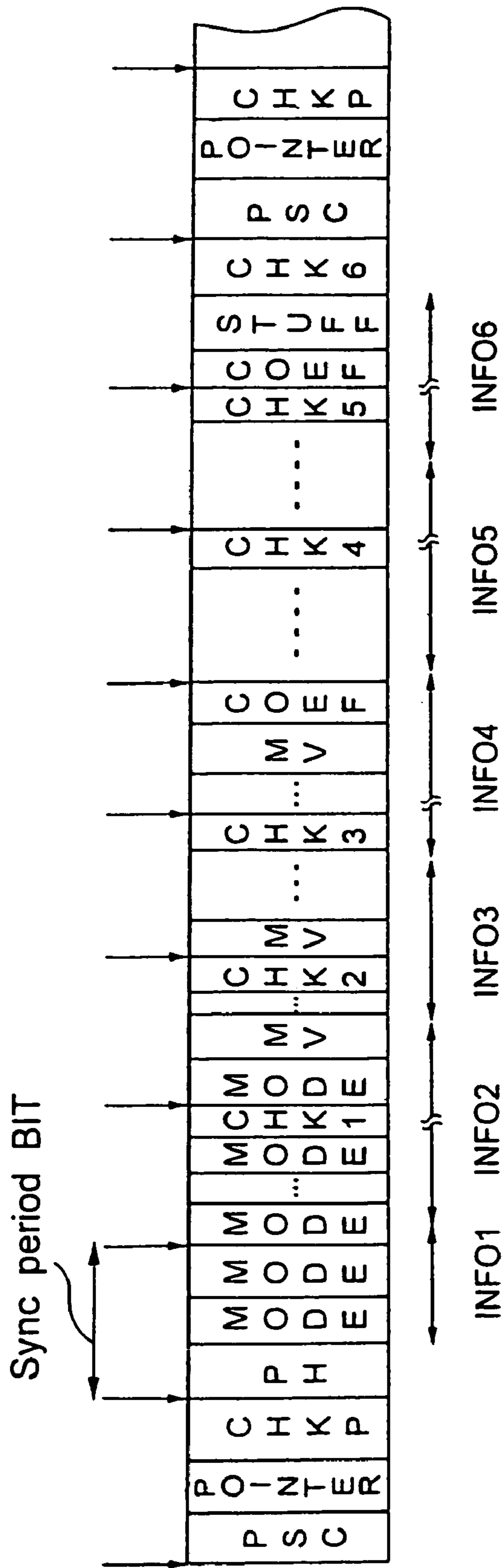

FIG. 15

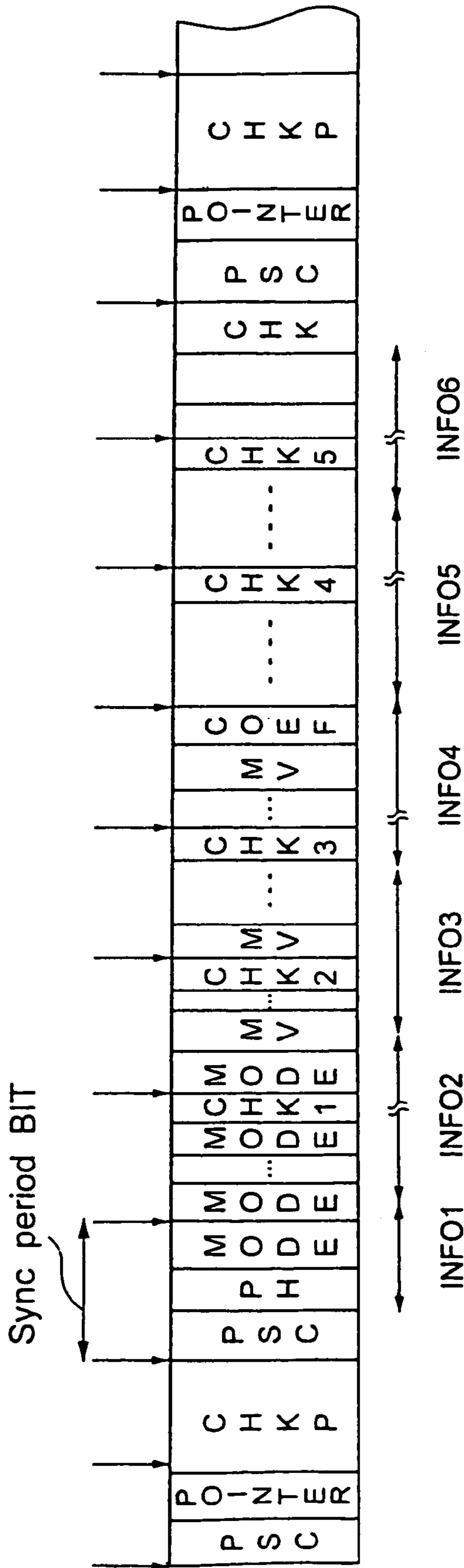

FIG. 16

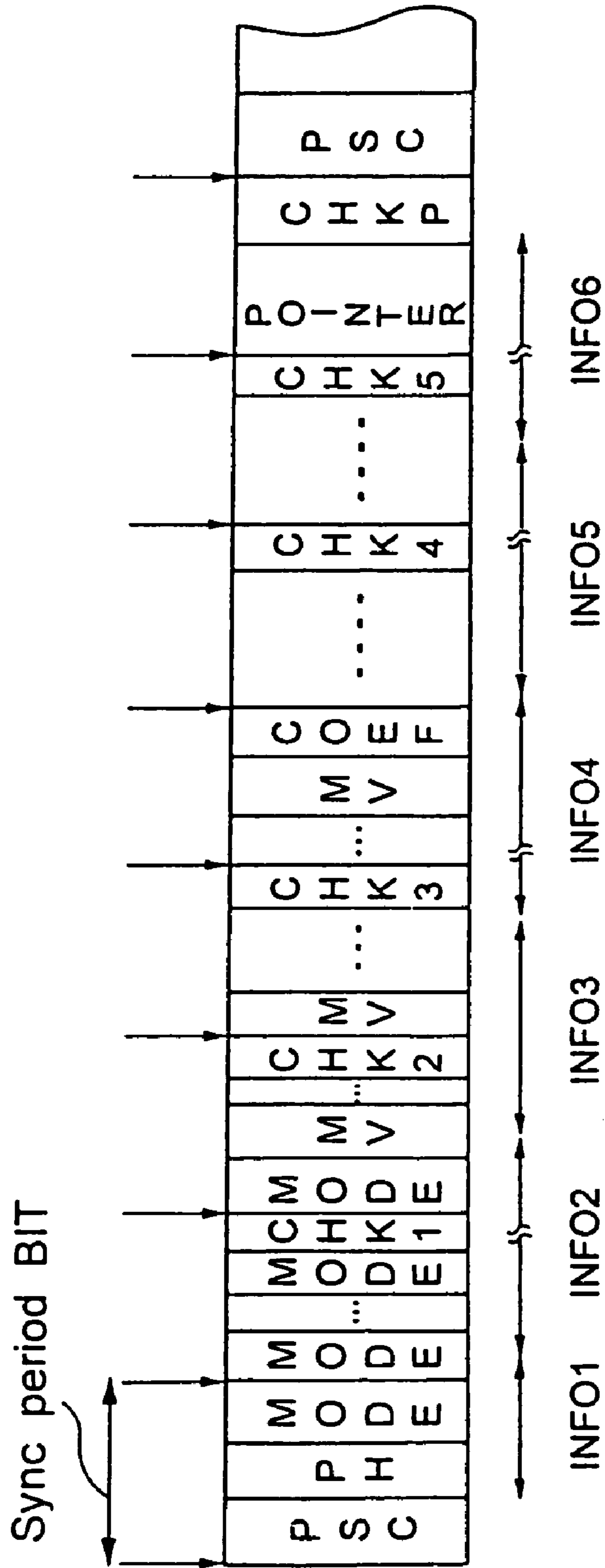

FIG. 17

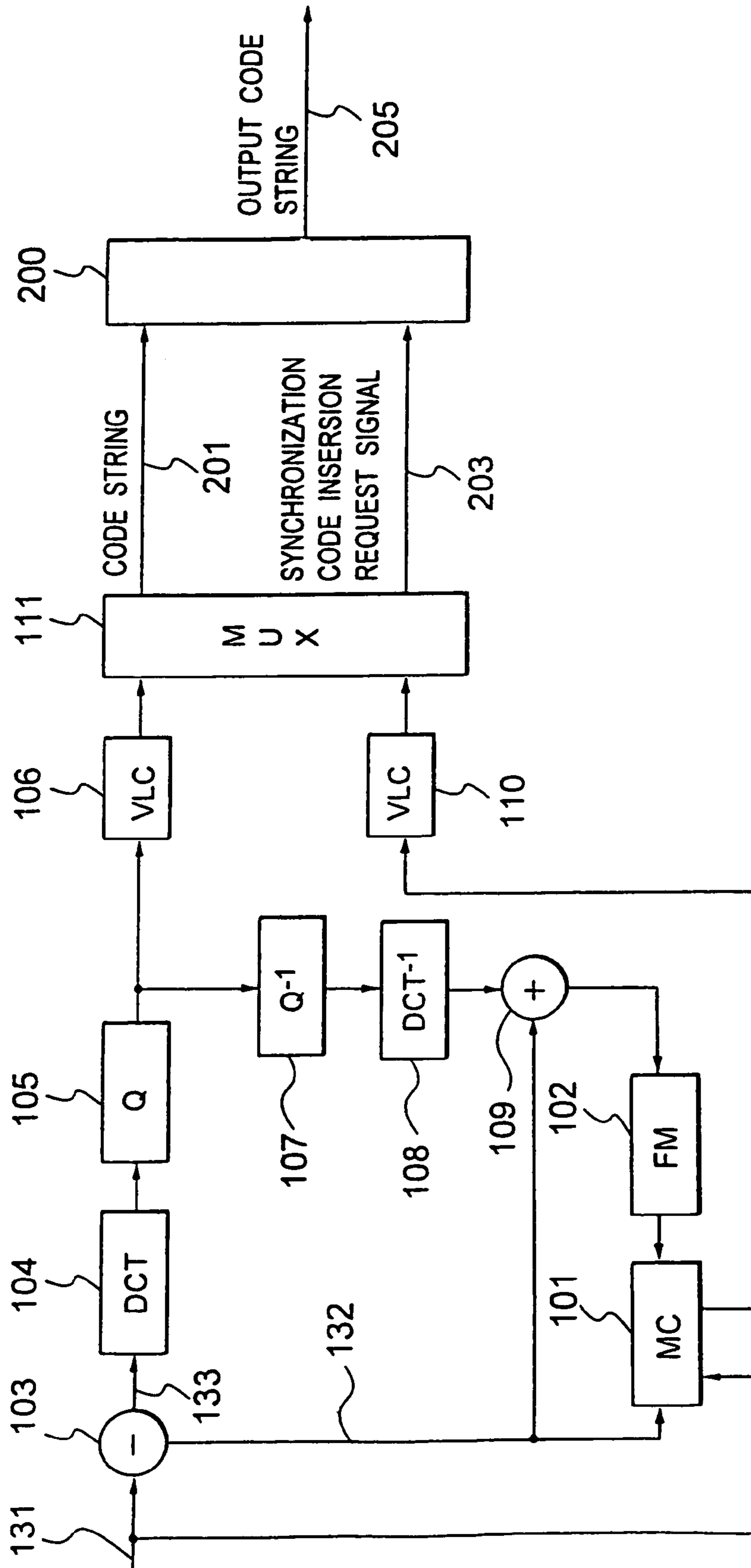

FIG. 18

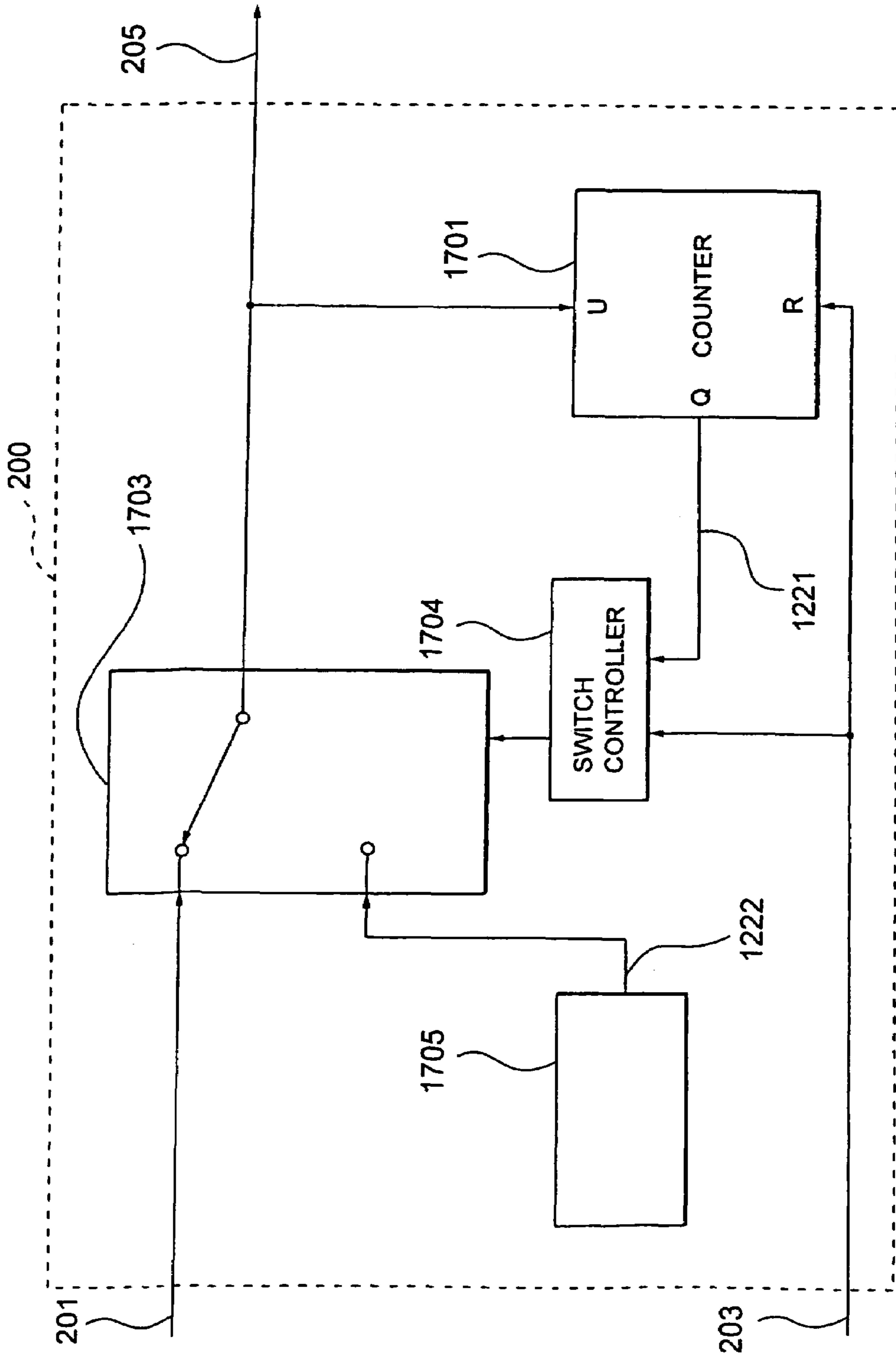

FIG. 19

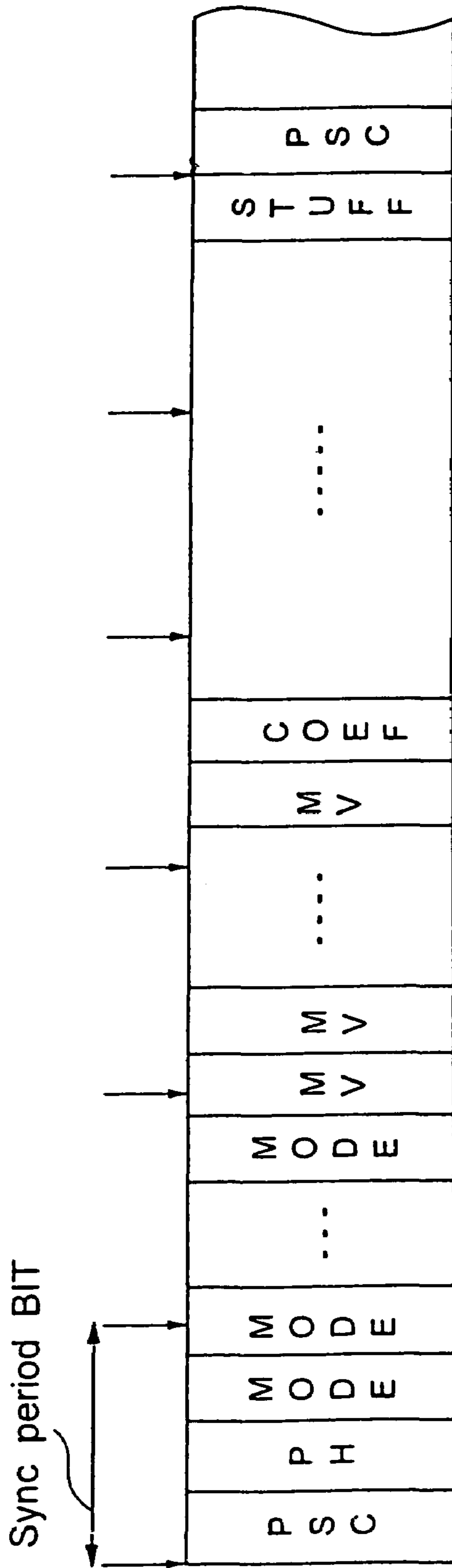

FIG. 20

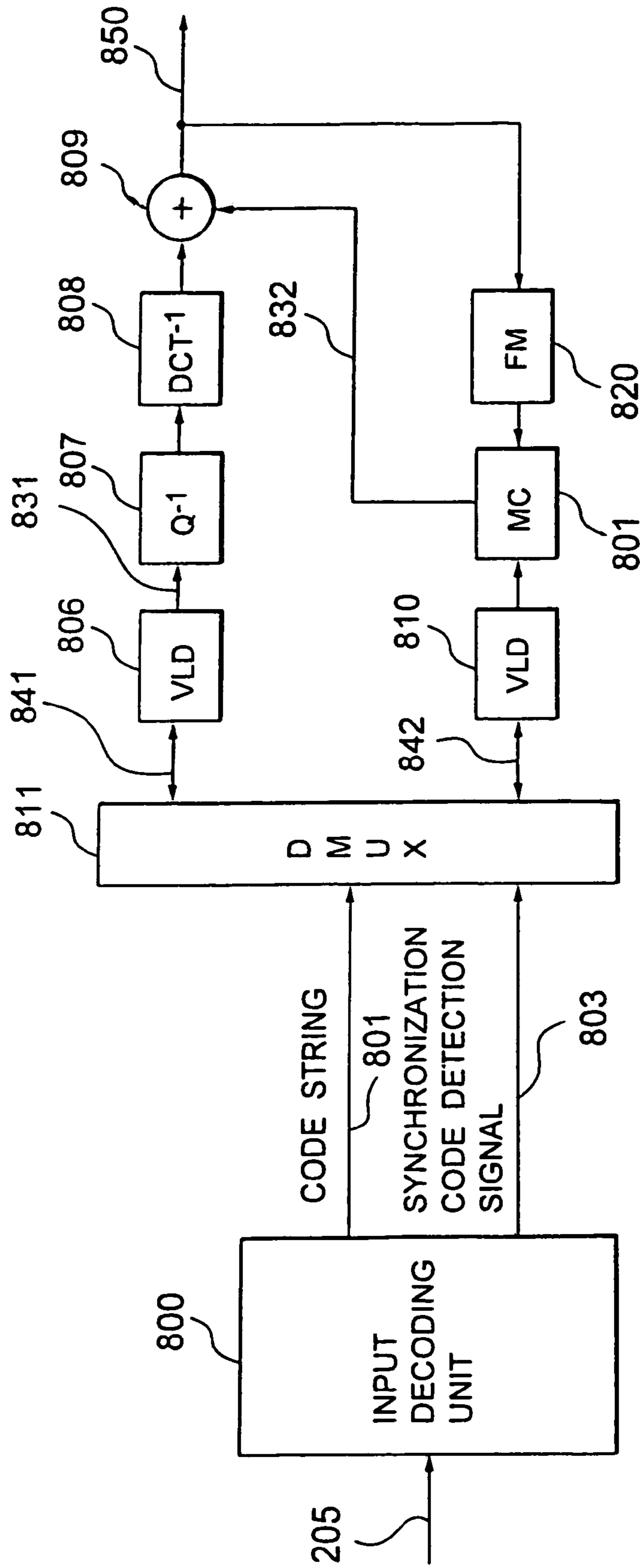

FIG. 21

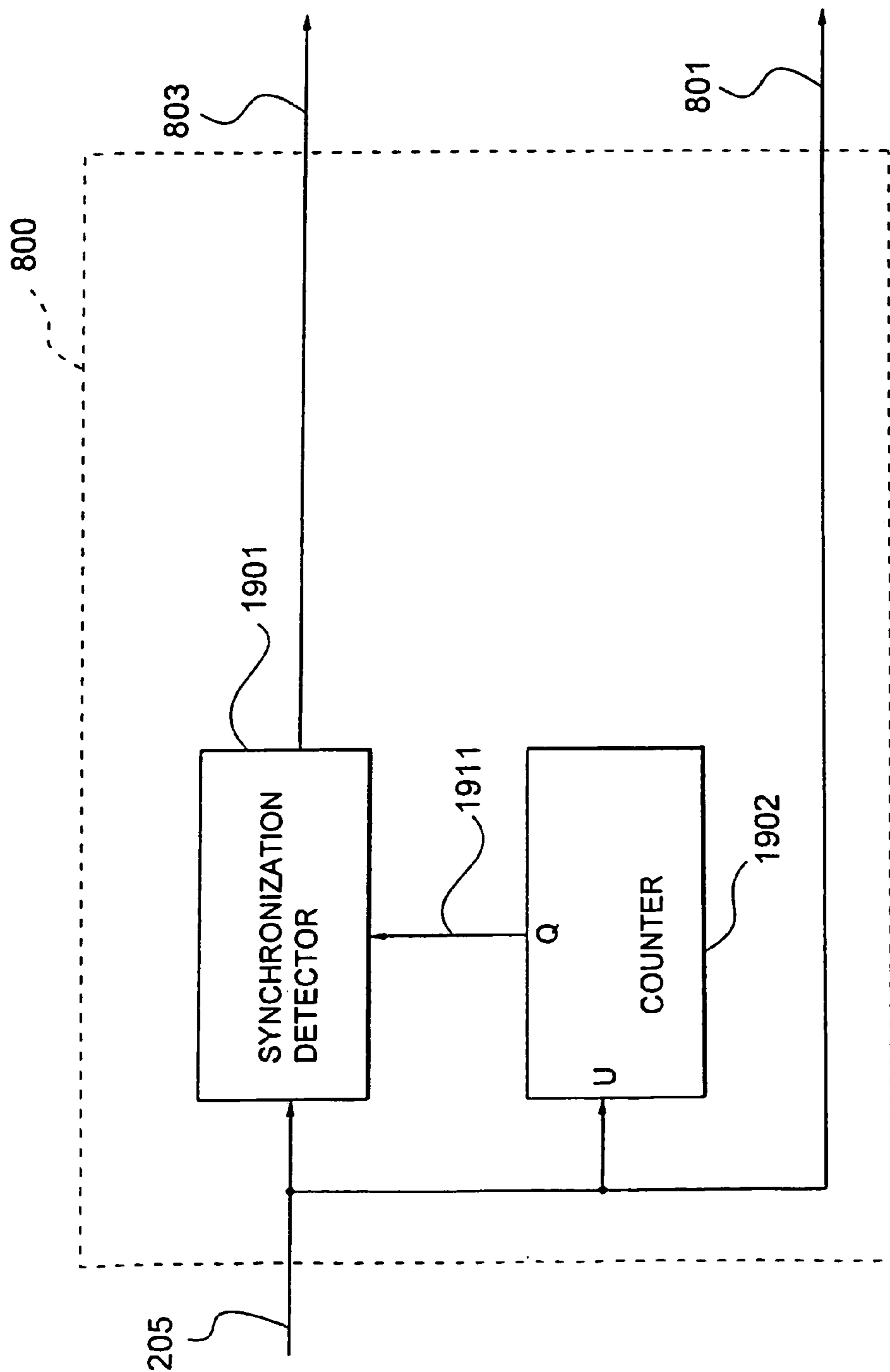

FIG. 22

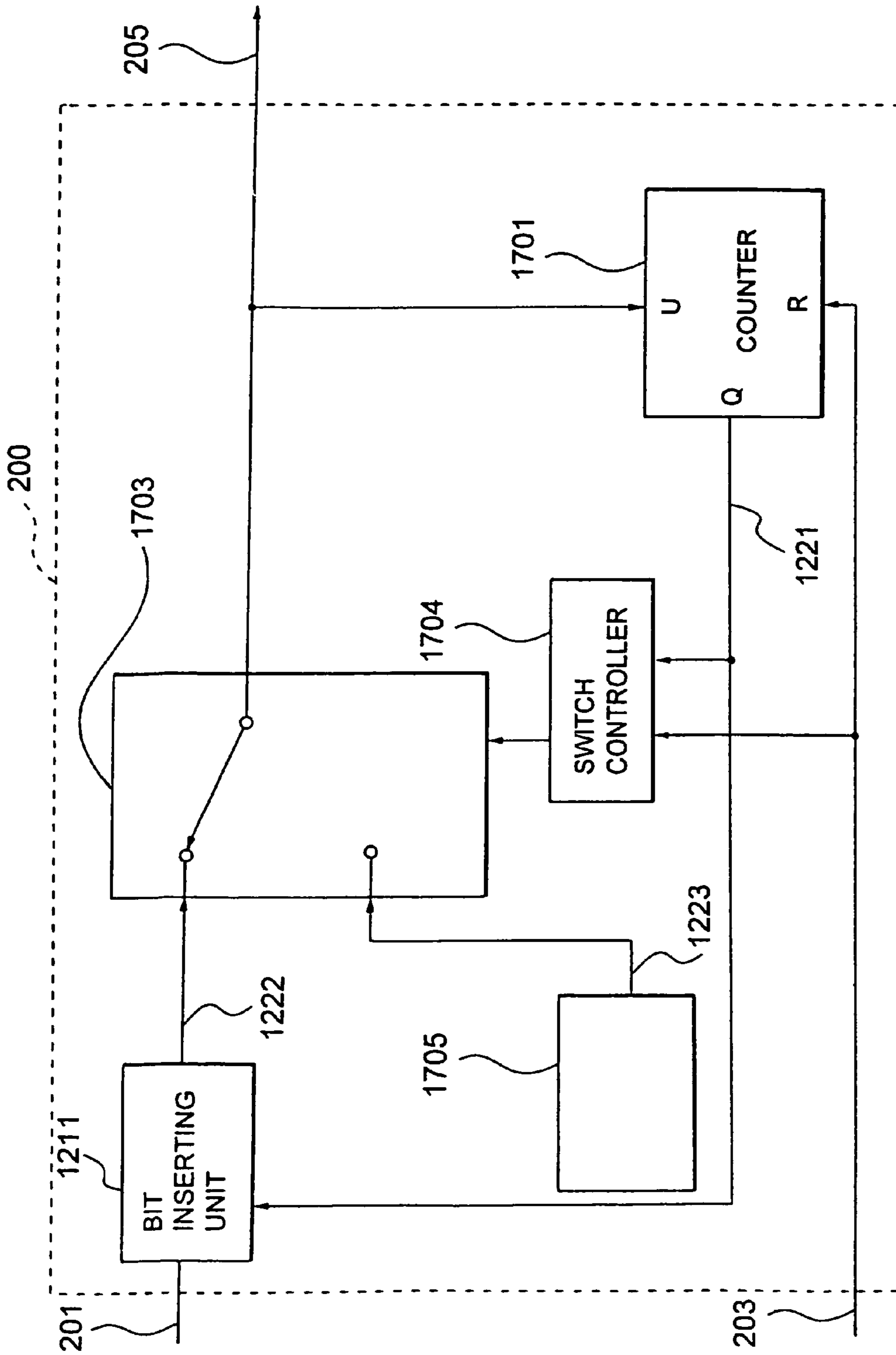

FIG. 23

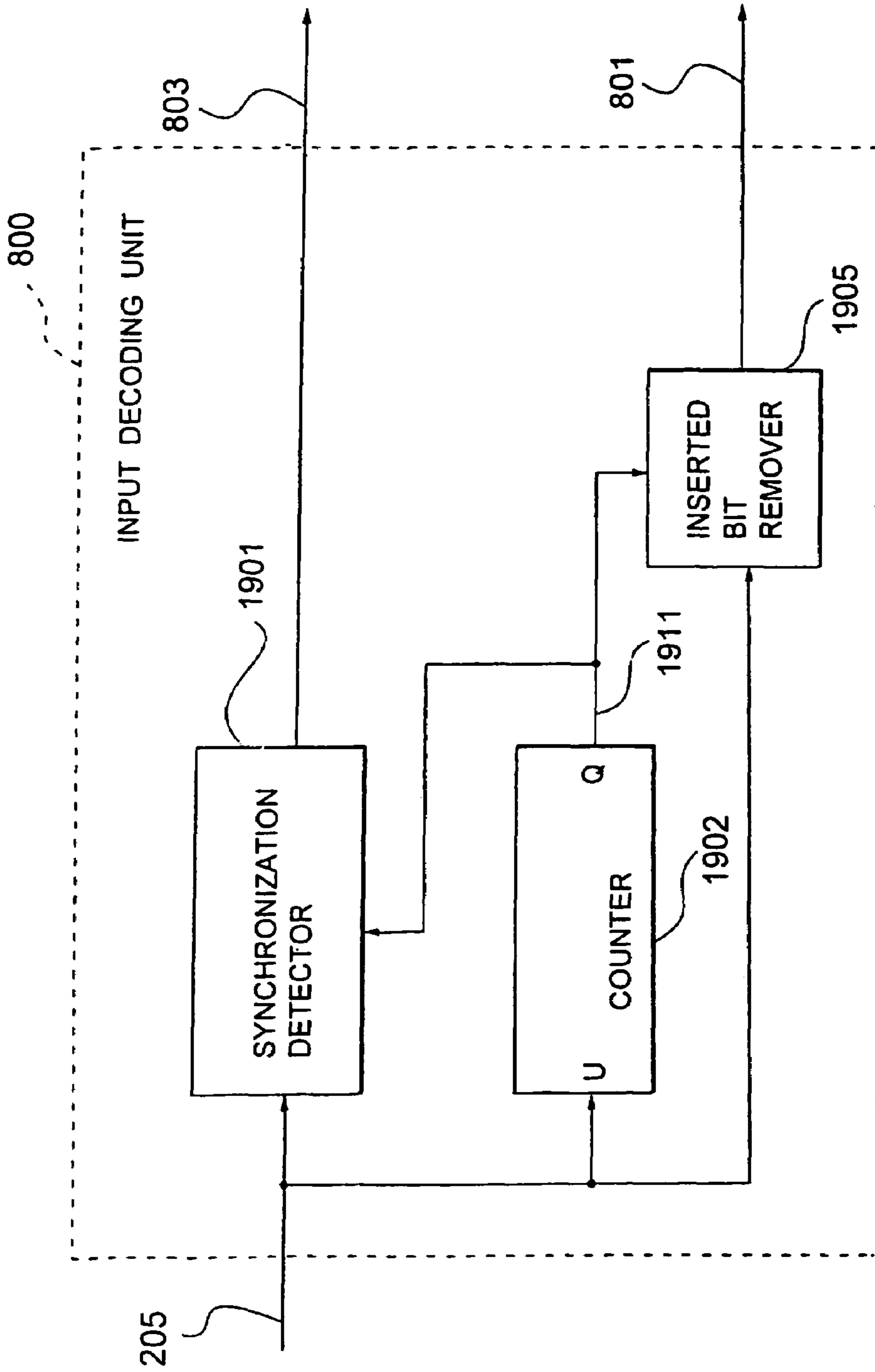
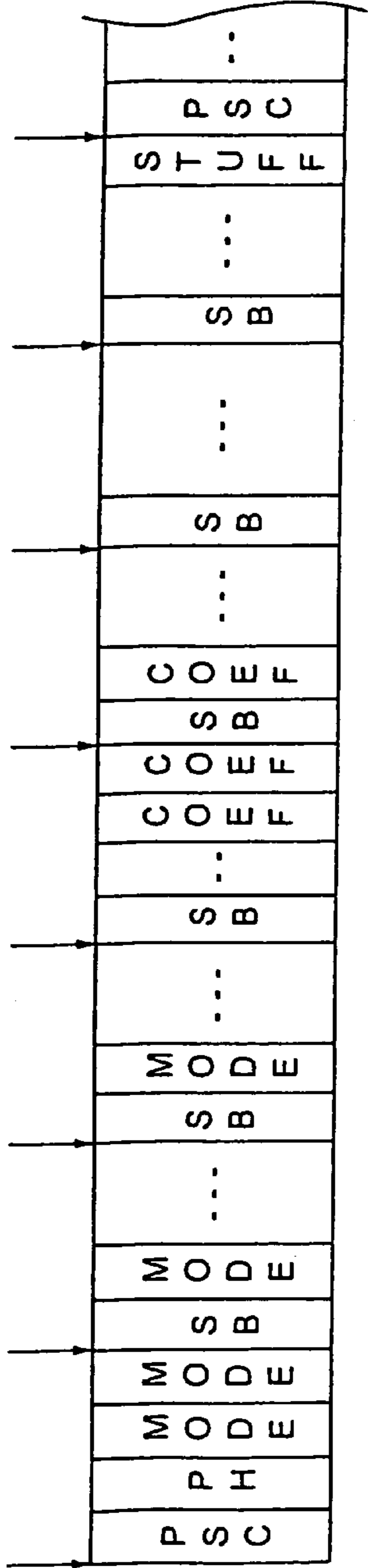
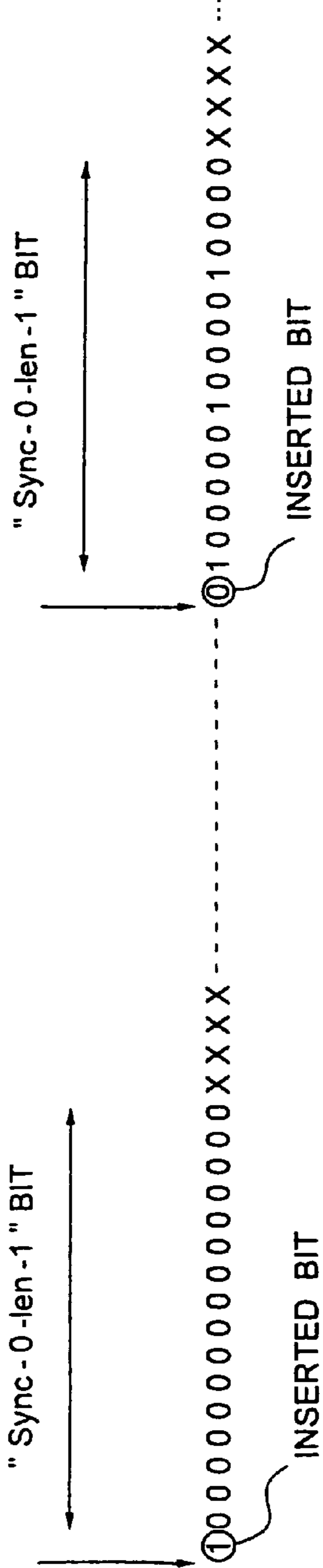

FIG. 24



(a)



(b)

FIG. 25

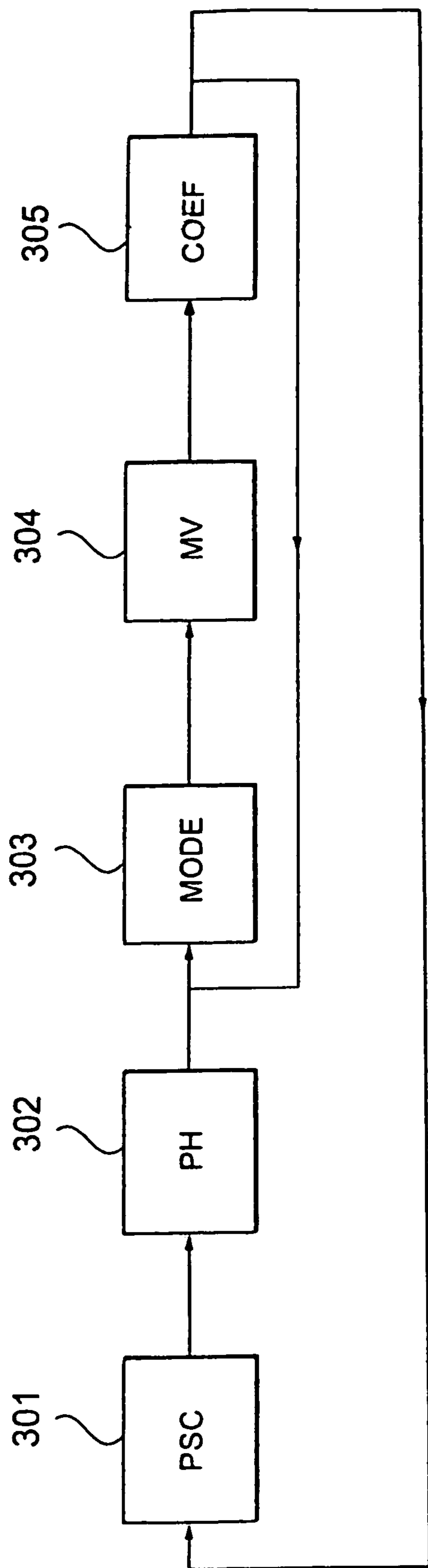

FIG. 26

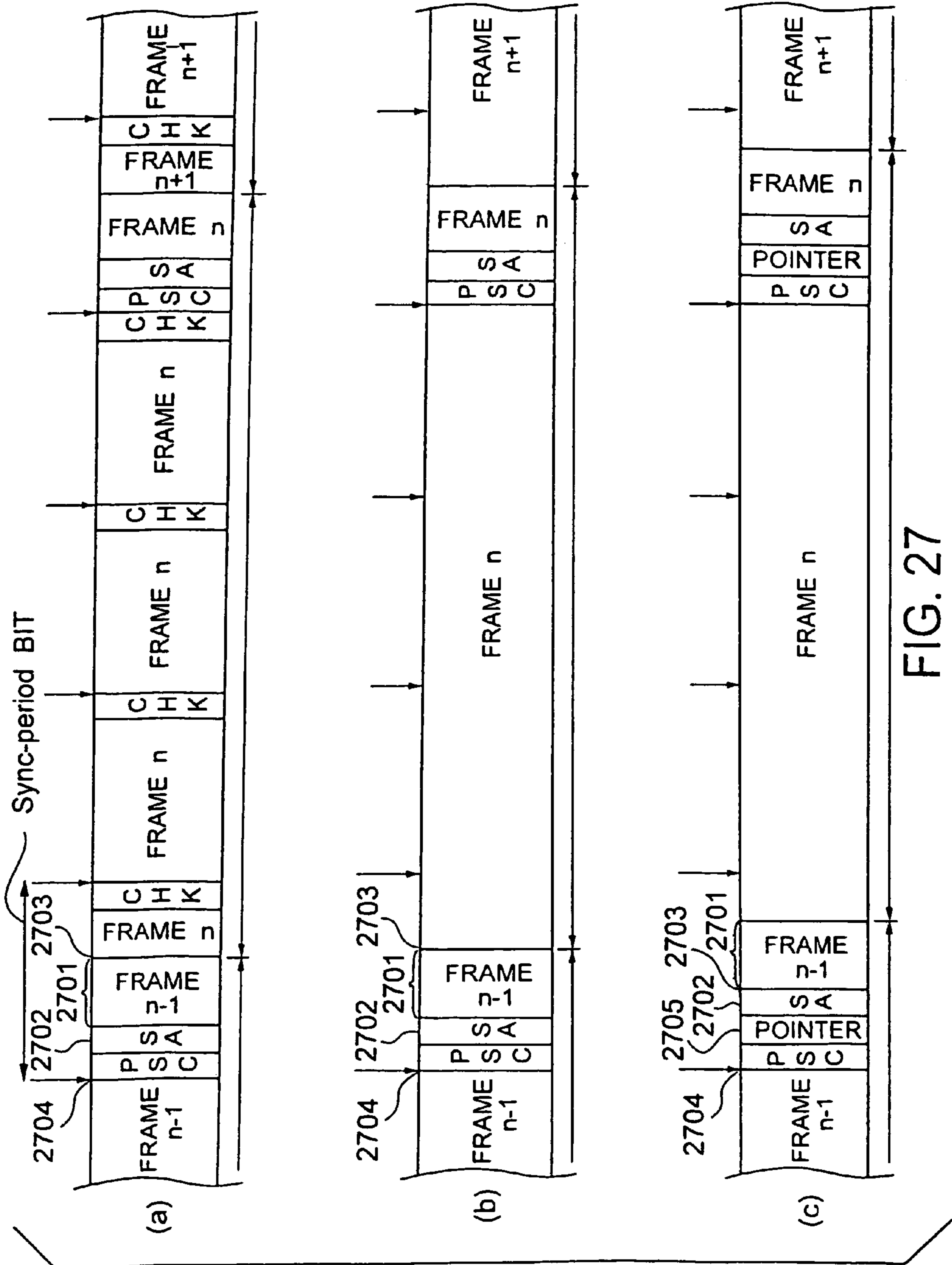

FIG. 27

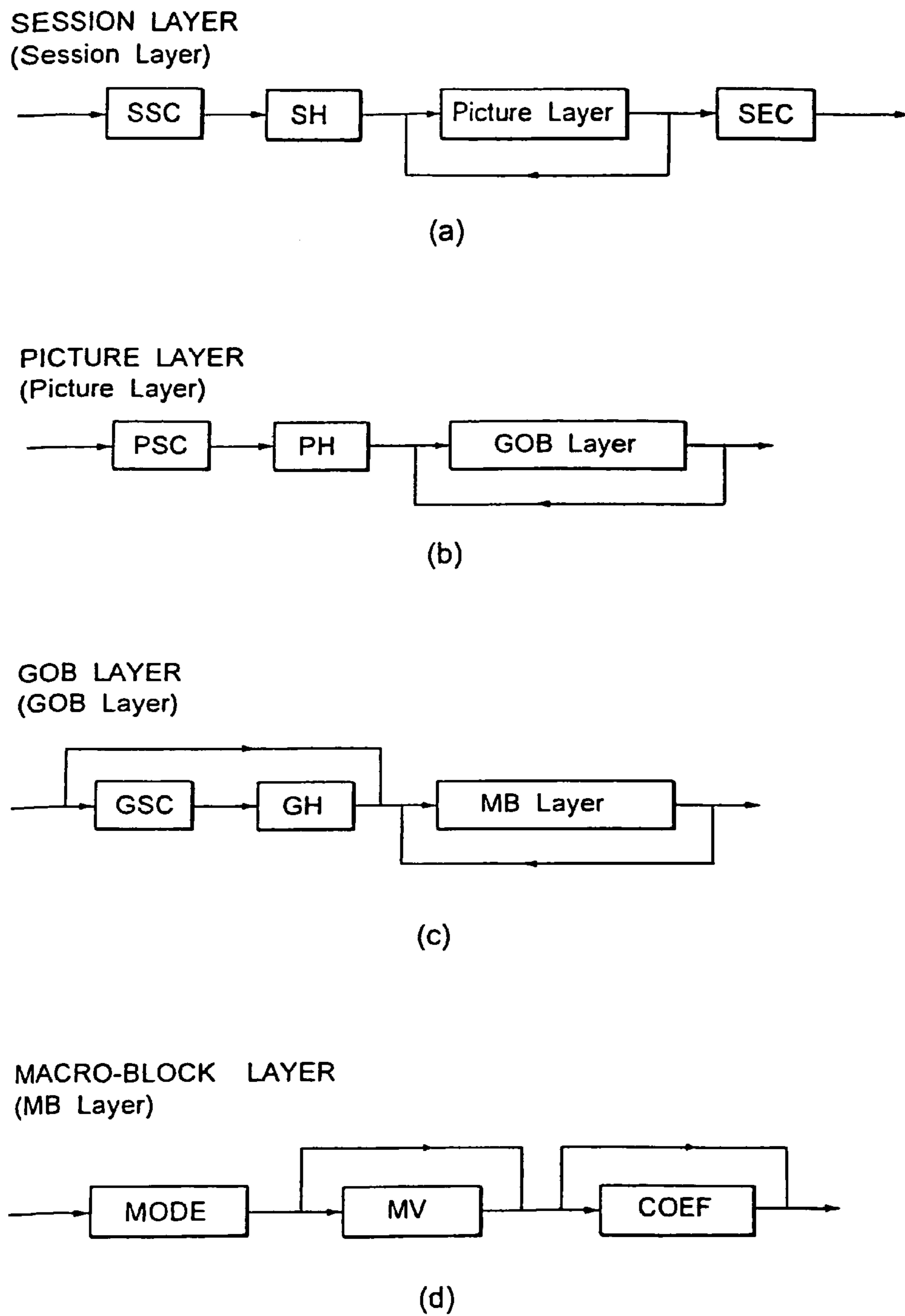

FIG.28

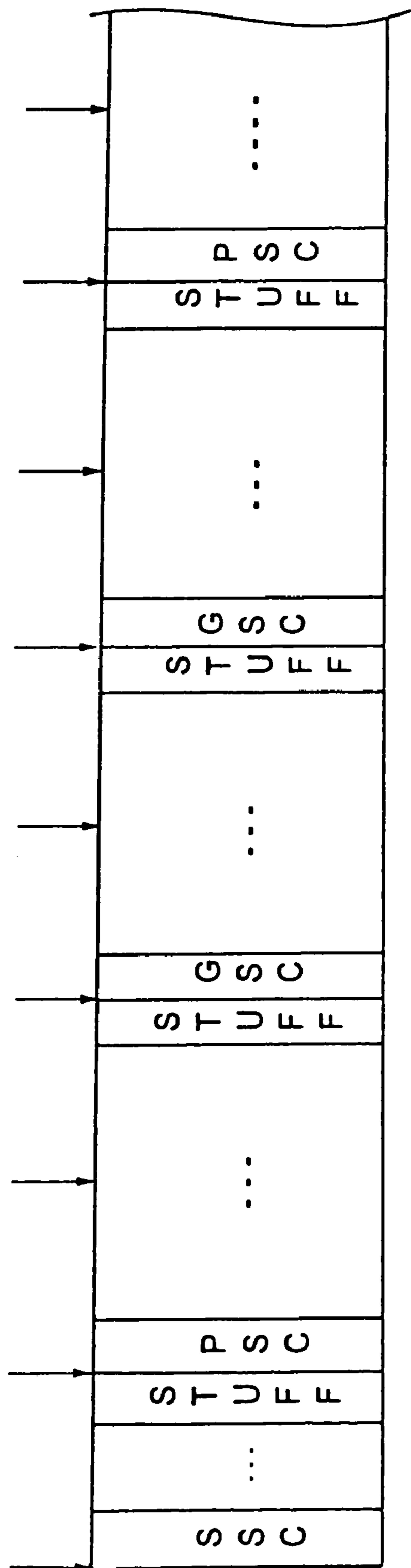

FIG. 29

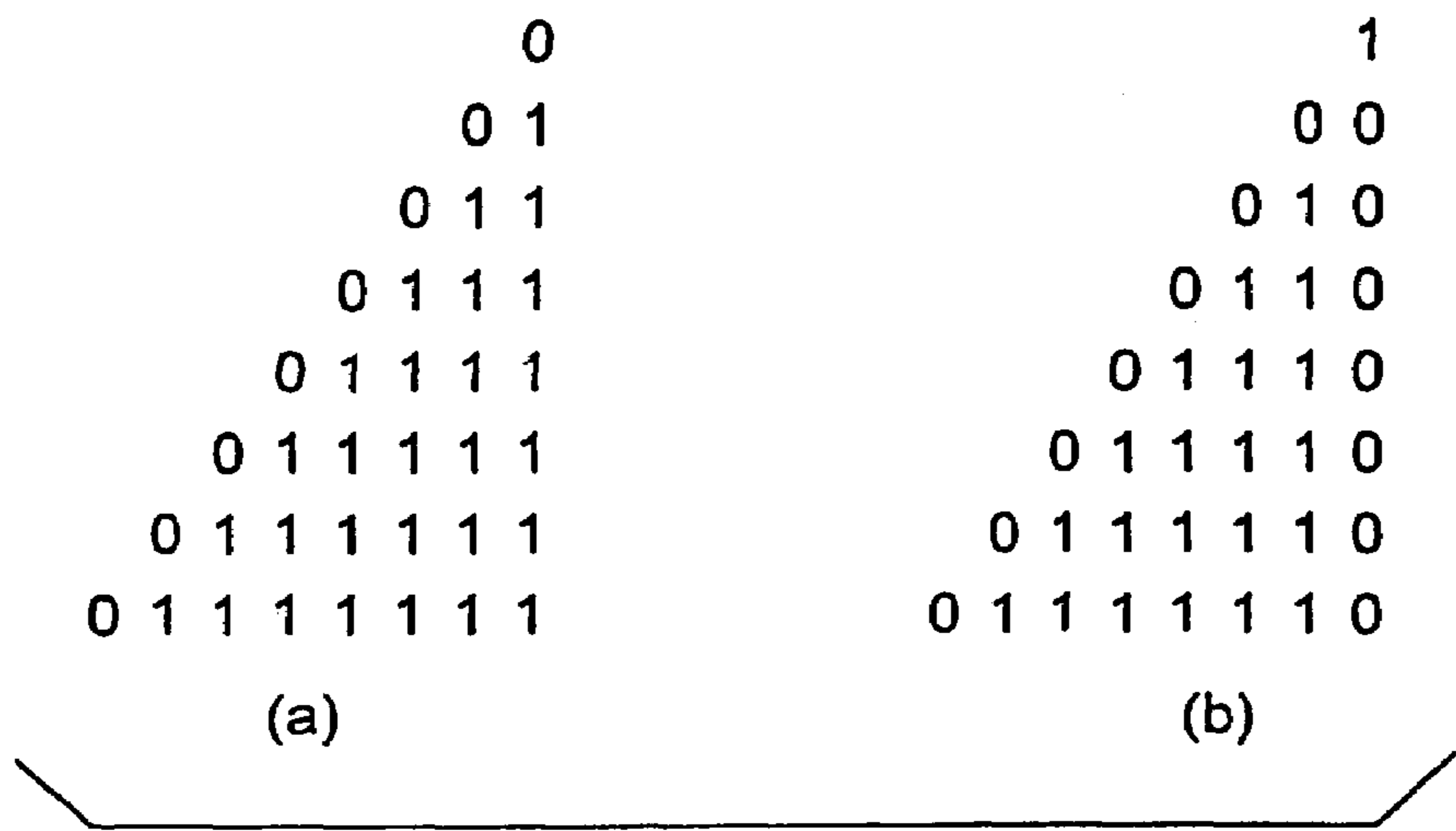

FIG.30

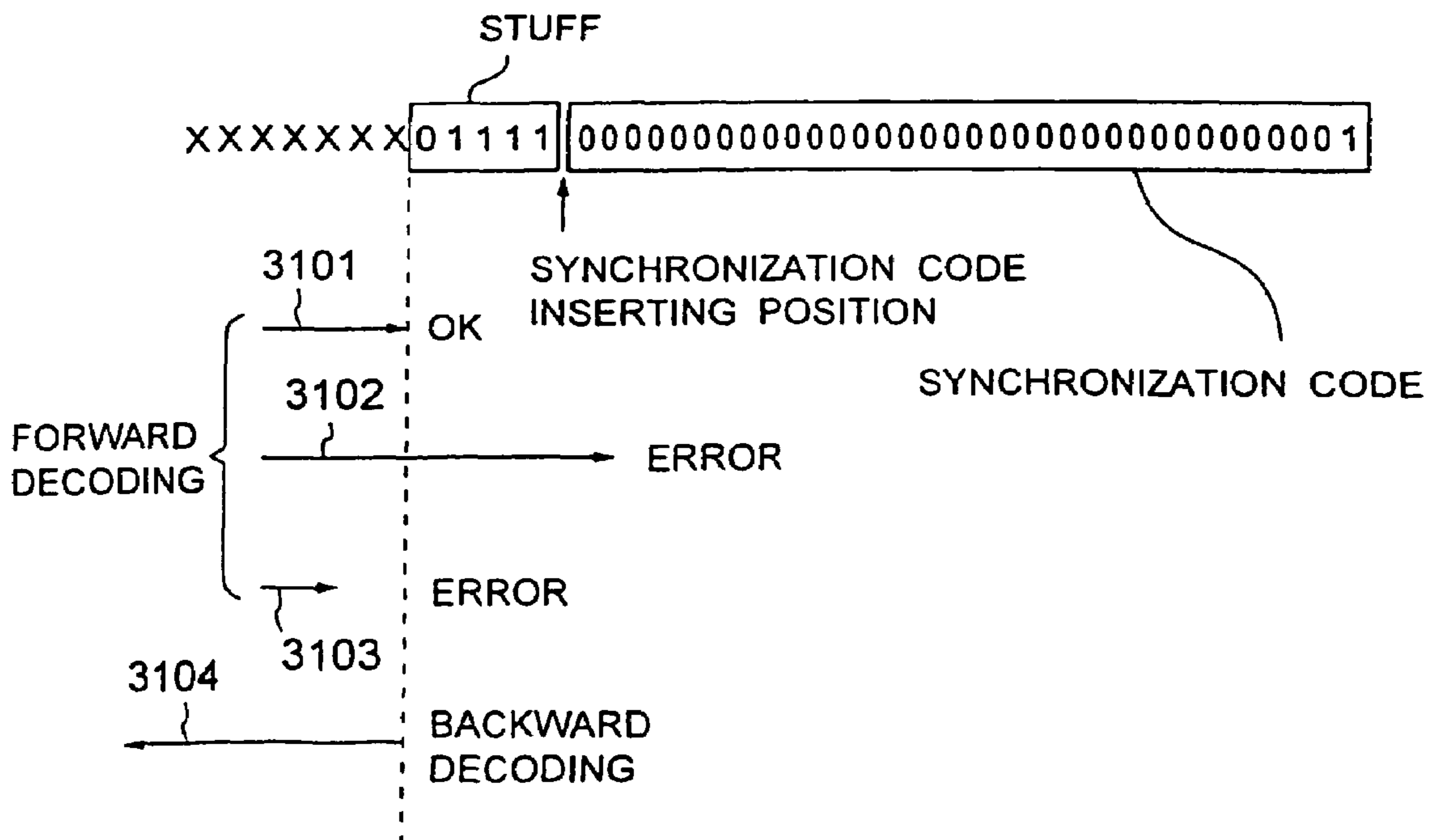

FIG.31

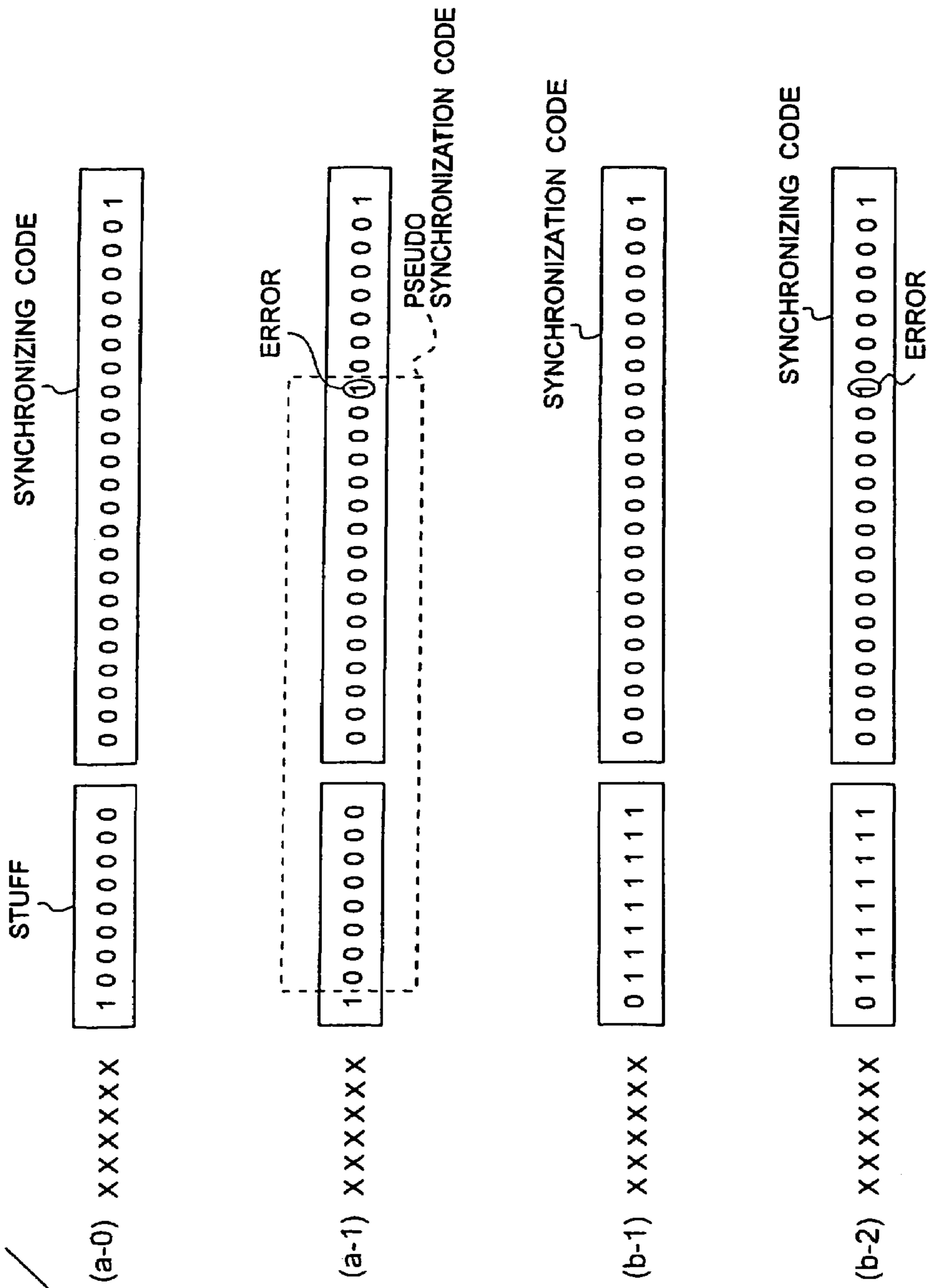

FIG. 32

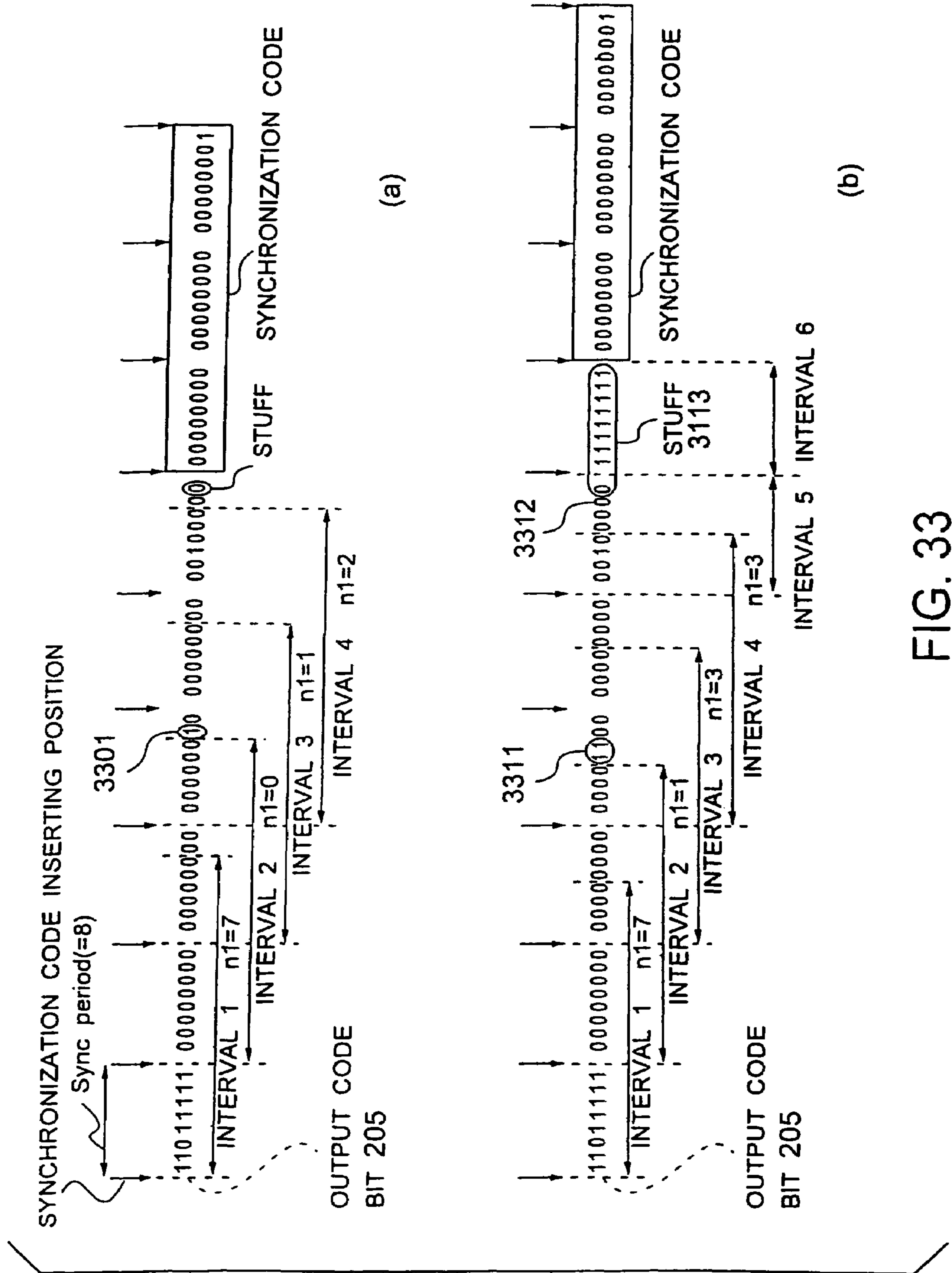
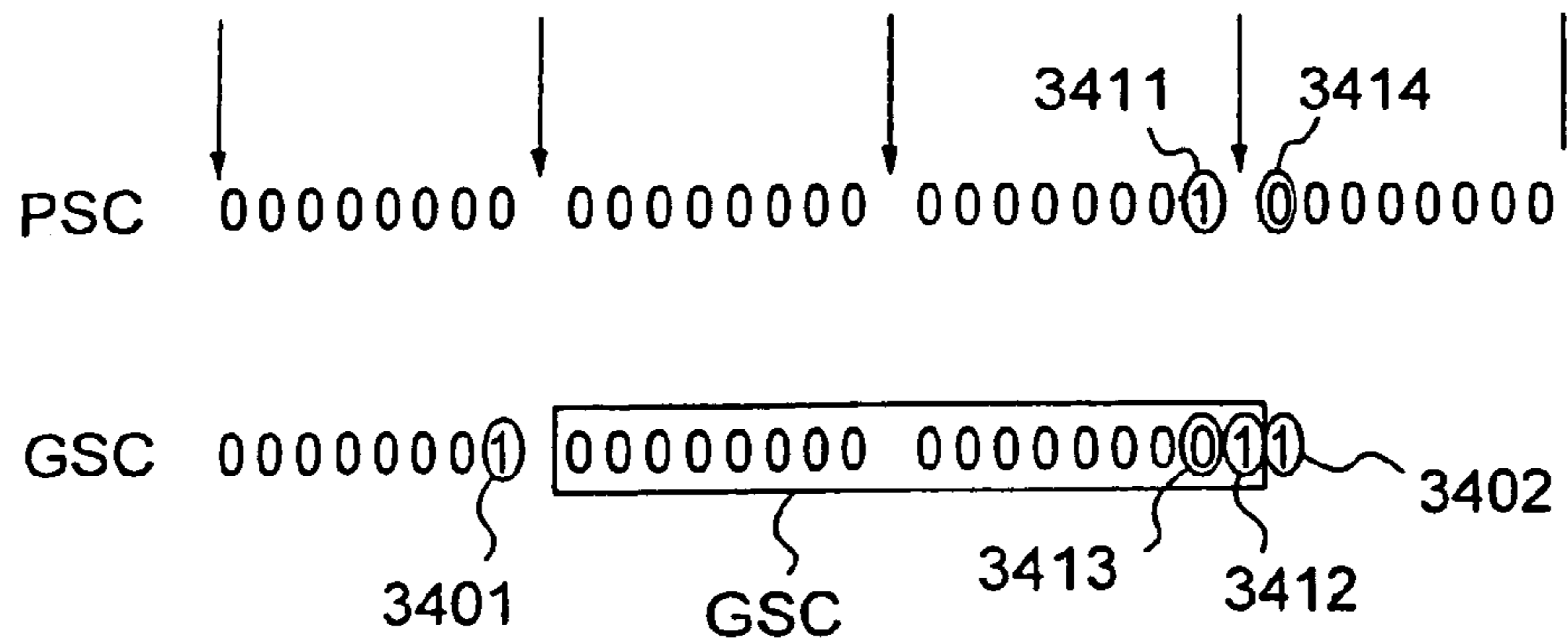

FIG. 33

SSC 00000000 00000000 00000001 00010101
SEC 00000000 00000000 00000001 00101010
PSC 00000000 00000000 00000001 00000000
GSC 00000000 00000000 1

(a)



(b)

FIG.34

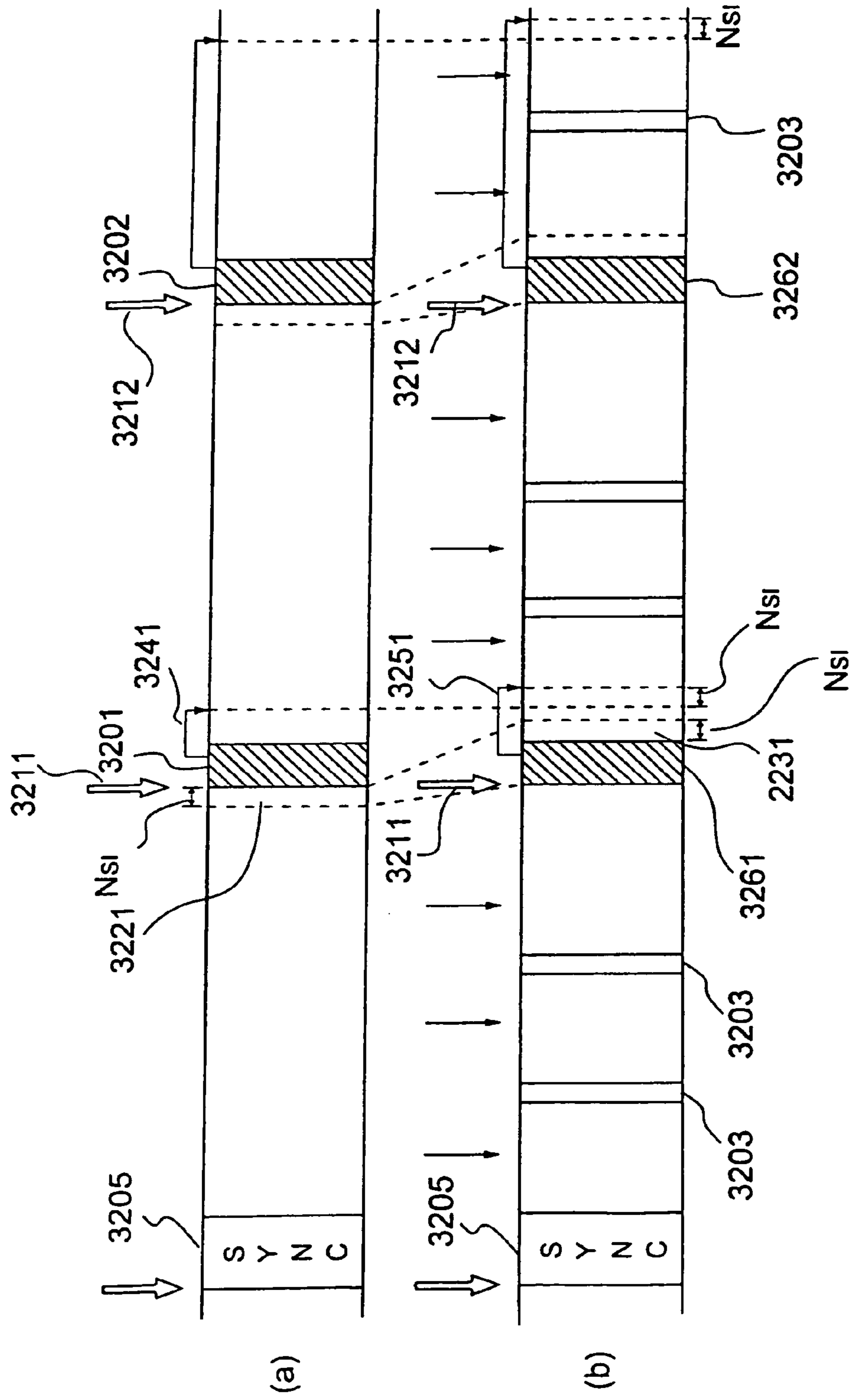

FIG. 35

CODING SYSTEM AND DECODING SYSTEM USING AN INPUT CODE STRING

This is a continuation of application Ser. No. 11/127,203, filed May 12, 2005, which is a continuation application of U.S. patent application Ser. No. 10/023,851, filed Dec. 21, 2001 (now U.S. Pat. No. 6,918,080, issued Jul. 12, 2005), which is a continuation application of U.S. patent application Ser. No. 09/142,871, filed Sep. 16, 1998 (now U.S. Pat. No. 6,571,361, issued May 27, 2003), which is a National Stage of International Application No. PCT/JP97/00864 under 35 U.S.C. 371, filed Mar. 18, 1997, which is a continuation-in-part of U.S. patent application Ser. No. 08/720,067, filed Sep. 27, 1996 (now U.S. Pat. No. 5,862,153, issued Jan. 19, 1999) all of which are incorporated herein by reference.

TECHNICAL FIELD

The present invention relates generally to a system for transmitting and/or storing information via a medium of a high error rate, such as a radio transmission line. More specifically, the invention relates to a coding and/or decoding system suited to carry out the error correction/detection coding of a compressed code string obtained by the high efficiency compression coding to transmit and/or store the compressed code string.

BACKGROUND ART

For example, in a system for carrying out the high-efficient compression coding of a picture and/or voice information so as to have a small information content to transmit the compression-coded picture and/or voice information via a radio transmission line, such as a radio visual telephone, a portable information terminal and a digital television broadcast system, it is important how to transmit the obtained code string with a high quality since the transmission line has a high error rate.

In a case where a code string is transmitted and/or stored via such a medium of a high error rate, an error correcting code, such as a Bose-Chaudhuri-Hocquenghem (BCH) code, a Recommended Standard (RS) code and a convolutional code, is often used as means for reducing the error rate. In addition, an error correcting code, such as a check sum and a cyclic redundancy check (CRC), is used as means for enabling the error correction on the receiving side. The aforementioned error correction and/or error detection adds excessive bits (redundancy) to the transmitted and/or stored information in accordance with a predetermined rule to examine whether the transmitted and/or stored code string obeys the rule during decoding, to carry out the error correction/detection on the basis of the results.

However, in such a method for coding a code string obtained by a high-efficiency compression coding into error correcting/detecting codes to transmit and/or store the codes, there is a disadvantage in that it is difficult to be combined with a synchronous recovering technique for recovering a step out caused by a code word error in the transmission line/medium. As a synchronous recovering technique, a method for inserting a uniformly decodable code called a synchronization code to resume the decoding immediately after the synchronization code is detected when a step out occurs is often used.

In order to make a uniformly decodable code word of the synchronization code, the code word must be combined with another code word so as not to form the same bit pattern as the synchronization code. However, in an error correction/de-

tection coding, it is generally difficult to form a code word so as to prevent a certain bit pattern from occurring. When the same bit pattern as the synchronization code occurs, a pseudo synchronization may be caused by the error detection of the synchronization code.

In order to avoid this problem, there is used a method for preventing the pseudo synchronization by determining whether the same bit pattern as the synchronization code exists in the code string after performing the error correction/detection coding, inserting a dummy bit into the bit pattern in accordance with a certain rule when the same bit pattern exists, and deleting the dummy bit in the same rule in a decoding system. However, in a case where the code string is transmitted and/or stored via a medium in which errors are easy to occur, errors may occur in the inserted bit, so that there is a problem in that a new step out or a new pseudo synchronization may occur.

In addition, in a case where the error correction/detection coding of a code string is carried out to insert a synchronization code, there is also a problem in that the coding efficiency is lowered since it is required to add many inserted bits to the code string in order to compensate an excess of information bits, for which the error detection and/or detection coding is to be carried out, at the end portion of a synchronization interval between the adjacent synchronization codes.

On the other hand, in order to enhance the error correcting/detecting capability, the redundancy of the transmitted and/or stored information may be enhanced. However, if the redundancy is enhanced, the number of bits required to transmit the same information is increased. Therefore, if the error correcting/detecting capability is enhanced, it is required to provide a transmission line of a higher transmission rate, or the number of bits of information to be stored is increased. In addition, if the transmission rate and the stored capacity are the same, the amount of information, which can be transmitted and/or stored, is decreased as the redundancy is enhanced. In a case where a picture and/or voice information is high-efficiently compression-coded to be transmitted and/or stored, in order to add the redundancy to improve the error resistance, the compression coding into a smaller amount of information must be carried out if the transmission and/or storage rate is the same, so that the picture quality and sound quality are lowered.

Therefore, as a method for providing a smaller redundancy and a high error resistance, there is a method called hierarchical coding. This is a method for enhancing the error resistance using the same means redundancy in comparison with when the same error correcting/detecting code is used, by classifying the high-efficiency compression-coded information in accordance with the magnitude of errors influencing the picture quality and the sound quality, using an error correcting/detecting code of a higher error correction/detection capacity while having a high redundancy, for information under a great influence of the error, and using an error correcting/detecting code of a less redundancy while having not so high error correction/detection capacity, for information which is not so greatly influenced by the error.

For example, in a coding system, which is formed by combining the motion-compensated prediction with the orthogonal transform and which is often used for the high-efficiency compression coding of a dynamic image, i.e., in a system for motion-compensation predicting an input dynamic image signal to orthogonal transform its prediction residue by a DCT (discrete cosine transform) or the like, the error correcting/detecting codes of a high error correcting/detecting capability are used for motion vector information, which greatly deteriorate the picture quality if an error occurs,

and for lower coefficients of the orthogonal transformation coefficients of the prediction residual signal, and the error correcting/detecting codes of a low error correcting/detecting capability are used for higher coefficients of the orthogonal transformation coefficients of the prediction residual signal, which are under a small influence of the error.

In order to achieve such a hierarchical coding, it is required to switch the error correcting/detecting codes of different error correcting/detecting capabilities in the middle of the output code string. As a method for switching the error correcting/detecting codes of different error correcting/detecting capabilities, there is a method for adding a header information representative of the kind of the error correcting/detecting codes to a code string. FIG. 11 shows an example of a code string, to which the header information is added to switch the error correcting/detecting codes. In this example, two kinds of error correcting/detecting codes FEC1 and FEC2 are switched. The headers 1101 to 1104 have a header information representative of the kind of the error correcting/detecting codes and the number of the code words. In a coding system, code words, which are error correction/detection coded, are arranged after the header information. In a decoding system, the header information is decoded, and the error correcting/detecting codes are decoded in accordance with the decoding of the header information.

However, in the method for switching the error correcting/detecting codes by adding such a header information, there is a problem in that the number of bits of the code string to be transmitted and/or stored by adding the header information is increased. In a case where the picture and/or voice information is high-efficiency compression coded to be transmitted and/or stored, if the number of bits is occupied by the header information, the number of bits used for the high-efficiency compression coding of the picture and/or voice information is decreased, so that the picture quality and sound quality are deteriorated.

As mentioned above, if the error correction/detection coding of the code string, in which the high-efficiency compression coding of dynamic image signals and so forth is performed, is carried out, an optional bit pattern is produced. Therefore, in a case where the error correction-/detection coding is combined with the synchronous recovering technique using a uniformly decodable synchronization code, there is a problem in that a pseudo synchronization is caused by the error detection of the synchronization code. Also in a case where the dummy bit is inserted to prevent the pseudo synchronization, there is a problem in that a new step out or a new pseudo synchronization is caused by the error of the inserted bit.

In addition, in a case where the error correction/detection coding of the code string is performed and the synchronization code is inserted, it is conventionally required to use many inserted bits to compensate an excess of information bits, for which the error detection and/or detection coding is to be carried out, at the end portion of a synchronization interval between the adjacent synchronization codes, so that there is a problem in that the coding efficiency is lowered.

Moreover, in a coding/decoding system for switching error correcting/detecting codes of different error correcting/detecting capabilities by adding a header information, the number of bits to be transmitted and/or stored by adding the header information is increased. Therefore, in a case where a picture and/or voice information is high-efficiency compression coded to be transmitted and/or stored, there is a problem in that the information content assigned to the picture and/or voice information is decreased to lower the picture quality and the sound quality.

DISCLOSURE OF INVENTION

It is therefore a principal object of the present invention to eliminate the aforementioned problems and to provide coding and decoding systems, which can prevent a pseudo synchronization and a step out due to the error detection of a synchronization code.

It is another object of the present invention to provide coding and decoding systems, which prevent a pseudo synchronization and a step out due to the error detection when an error correction/detection coding is combined with a synchronization recovering technique using a synchronization code.

It is further object of the present invention to provide coding and decoding systems, which can decrease the number of inserted bits used at the end portion in a synchronization interval to enhance the coding efficiency, when an error correction/detection coding is combined with a synchronization recovering technique using a synchronization code.

It is still further object of the present invention to provide coding and decoding systems which can decrease the number of bits of a code string, to which a header information representative of the kind of error correction/detection coding must be added and which is transmitted and/or stored, to improve the quality of information.

(1) A first coding system, according to the present invention, comprises: coding means for coding an input code string to an error correcting/detecting code comprising an information bit and a check bit; and code string assembling means for inserting a synchronization code into any one of a plurality of predetermined synchronization code inserting positions in an output code string, for arranging the information bit at an optional position in the output code string, and for arranging the check bit at a position other than the synchronization code inserting positions in the output code string to assemble the output code string.

A first decoding system, according to the present invention, comprises: synchronization code detecting means for detecting a synchronization code at a plurality of predetermined synchronization code inserting positions on the basis of a code string, which is coded to an error correcting/detecting code comprising an information bit and a check bit; code string resolving means for resolving the code string to extract the information bit of the error correcting/detecting code and the check bit of the error correcting/detecting code arranged at a position other than the synchronization code inserting positions; and decoding means for receiving the information bit and the check bit extracted by the code string resolving means to decode the error correcting/detecting code.

Thus, in the first coding/decoding system, the synchronization code exists only at the predetermined synchronization code inserting position in the output code string, and the check bit of the error correcting/detecting code exists at a position other than the synchronization code inserting position. Therefore, even if the same bit pattern as the synchronization code is contained in the check bit, there is no probability that it is erroneously detected that the same bit pattern as the synchronization code is a synchronization code. Accordingly, since it is not required to use a special error correcting/detecting code for preventing a particular bit pattern and to insert a bit for preventing a synchronization code after the error correction/detection coding, the degree of freedom for the used error correcting/detecting code can be increased. In addition, since there is no probability that a new synchronization detection error may occur due to the insertion of an error into an inserted bit, it is possible to improve the resistance to errors.

5

(2) In a second coding system according to the present invention, code string transforming means is added to the first coding system. The code string transforming means transforms an input code string other than synchronization codes arranged at a plurality of predetermined synchronization code inserting positions in an output code string so that a humming distance from the synchronization code is equal to or greater than a predetermined value. The code string transformed by the code string transforming means is inputted to coding means to be coded to an error correcting/detecting code comprising an information bit and a check bit.

In a second decoding system according to the present invention, code string transforming means is added to the first decoding system. The code string transforming means transforms a code string other than the synchronization code, which exists at a synchronization code inserting position and which is transformed so that a humming distance from the synchronization code in the code string decoded by the decoding means is equal to or greater than a predetermined value, into the original code string.

Thus, in the second coding/decoding system, the coding system carries out the transforming process so that the humming distance from the synchronization code with respect to a bit string arranged at the synchronization code inserting position is equal to or greater than a predetermined value, and the decoding system carries out the reverse transformation. Therefore, since the same bit pattern as the synchronization code is not contained in the bit string, it is possible to prevent the error detection of a synchronization code. In addition, if the transform is carried out so that the humming distances between the synchronization code and the other code strings are great, the synchronization code can be distinguished from the other code strings even if an error is mixed into the code strings, so that the probability of the error detection of the synchronization code due to errors can be decreased.

Since this transforming/inverse transforming process is carried out only at the synchronization code inserting position, the overhead is less than those in conventional methods for carrying out transforming/inverse transforming process over the whole code string. In addition, in the code string inputted to the coding system, it is not required to carry out the transforming process so as not to produce the same bit pattern as the synchronization code, and it is not required to use a special code string. In particular, in a case where a variable length coding system for switching and using different code word tables is used as an input of this coding system, if the code word table is prepared so as not to produce the same pattern as the synchronization code in the variable length coding system, there is a problem in that the coding efficiency is lowered. However, the second coding/decoding system can eliminate such a problem.

(3) A third coding system, according to the present invention, comprises: coding means for coding an input code string to an error correcting/detecting code; synchronization code inserting means for inserting a synchronization code into the code string; and determining means for determining the number of bits an information to be coded to an error correcting/detecting code immediately before the synchronization code in the code string, wherein the coding means causes the error correcting/detecting code immediately before the synchronization code, to be a degenerate code, which adaptively degenerates on the basis of the number of bits determined by the determining means.

A third decoding system, according to the present invention, comprises: decoding means for decoding a code string, which is coded to an error correcting/detecting code and into which a synchronization code is inserted; synchronization

6

code detecting means for detecting the synchronization code in the code string; and determining means for determining the number of bits of an information, which is coded to an error correcting/detecting code immediately before the synchronization code in the code string detected by the synchronization code detecting means, wherein the decoding means decodes by identifying whether the error correcting/detecting code immediately before the synchronization code is a degenerate code on the basis of the determined result of the determining means.

Thus, in the third coding/decoding system, since a degenerate code degenerated to the number of bits required to code the information bit remaining at the end portion of a synchronization interval is used as the error correcting-/detecting code immediately before the synchronization code, it is not required to use many inserted bits in order to compensate the remainder of the information bit at the end portion of the synchronization interval, so that the coding efficiency can be improved.

(4) A fourth coding system, according to the present invention, comprises: coding means for coding a code string containing kinds of input information to an error correcting/detecting code; and switching means for switching the kind of the error correcting/detecting code in accordance with the kinds of the input information in the code string.

A fourth decoding system, according to the present invention, comprises: decoding means for decoding a code string, which is coded to a different kind of error correcting-/detecting code in accordance of the kind of information, to generate the original information; and means for determining the kind of the error correcting/detecting code on the basis of the kind of information generated by the decoding means, to inform the decoding means.

Thus, in the fourth coding/decoding system, in a case where the coding/decoding is carried out by switching the error correcting/detecting-code in accordance with the kind of information, the coding system switches the error correcting/detecting code in accordance with the kind of information of the input code string, and the decoding system determines the kind of the error correcting-/detecting code on the basis of the decoded information to carry out the same switching as that of the coding system. Therefore, it is not required to use a header information representative of the kind of the error correcting/detecting code unlike conventional systems, so that it is possible to remove the overhead due to the header information.

(5) A fifth coding system, according to the present invention, comprises: code string transforming means for transforming an input code string other than synchronization codes, which are arranged at a plurality of predetermined synchronization code inserting positions in an output code string and in intervals of a predetermined number of bits before and after the predetermined synchronization code inserting positions in an output code string, so that a humming distance from the synchronization code is equal to or greater than a predetermined value; coding means for coding a code string transformed by the code string transforming means, to an error correcting-/detecting code comprising an information bit and a check bit; and code string assembling means for inserting a synchronization code into any one of a plurality of predetermined synchronization code inserting positions in the output code string, for arranging the information bit at an optional position in the output code string, and for arranging the check bit at a position other than the synchronization code inserting positions in the output code string to assemble the output code string.

A fifth decoding system, according to the present invention, comprises: synchronization code detecting means for detecting synchronization code at a predetermined synchronization code inserting position and in an interval of a predetermined number of bits before and after the predetermined synchronization code inserting position, on the basis of a code string, which is coded to an error correcting/detecting code comprising an information bit and a check bit and into which the synchronization code; code string resolving means for resolving the code string to extract the information bit of the error correcting-/detecting code and the check bit of the error correcting/detecting code arranged at a position other than the synchronization code inserting position; decoding means for receiving the information bit and the check bit extracted by the code string resolving means to decode the error correcting/detecting code; and code string transforming means for transforming a code string other than the synchronization code, which is transformed so that a humming distance from the synchronization code in the code string decoded by the decoding means is equal to or greater than a predetermined value and which exists at the synchronization code inserting position and in an interval of a predetermined number of bits before and after the synchronization code inserting position, into the original code string.

Thus, in the fifth coding/decoding system, the input code string is transformed in the synchronization code inserting interval as well as in the interval of the predetermined number of bits before and after the synchronization code inserting interval so that the humming distance is equal to or greater than the predetermined value, and the decoding system carries out the reverse transformation of the input code string, so that the same bit pattern as the synchronization code is not contained in this interval. Therefore, even if the transmission/storage of a bit string coded through a transmission line or a storage medium for causing a bit loss, in which a part of bits is lost, and a bit addition, in which an excess bit is added, is carried out, the synchronization code can be distinguished from the other code strings if the number of lost/added bits is equal to or less than a predetermined number of bits, so that the decoding system can correctly carry out the synchronization detection.

(6) A sixth coding system, according to the present invention, comprises: multiplexing means for multiplexing kinds of compressed codes, which are obtained by compression coding an input signal, to produce a multiplexed code string; and code string assembling means for inputting the multiplexed code string to assemble an output code string, wherein the code string assembling means inserts a synchronization code into any one of a plurality of periodically predetermined synchronization code inserting positions in the output code string.

In this case, in order to insert the synchronization code into any one of the plurality of periodically predetermined synchronization code inserting positions in the output code string, the code string assembling means inserts a stuffing bit into the output code string, or periodically determines the plurality of synchronization code inserting positions in the output code string and inserts an information (a pointer information) representative of the boundary of the multiplexed code string, to insert the synchronization code into any one of the plurality of synchronization code inserting positions. Thus, the synchronization code can be inserted only into any one of the plurality of periodically predetermined synchronization code inserting positions.

The stuffing bit is preferably a code, which can be uniformly decoded in a backward direction of the output code string. Thus, if the decoding system compares the decoding

end position of the code string immediately before the stuffing bit with the starting position of the stuffing bit, it is possible to easily detect an error in the input code string.

Moreover, the humming distances of the stuffing bit from the synchronization code and the part thereof are preferably equal to or greater than a predetermined value. Thus, there is an advantage in that the probability of the occurrence of a pseudo synchronization.

A sixth decoding system, according to the present invention, comprises: synchronization code detecting means for detecting a synchronization code in an output code string; demultiplexing means for demultiplexing on the basis of the position of the synchronization code detected by the synchronization code detecting means from the input code string, to produce a compressed code string; and decoding means for decoding the compressed code to output a reconstructed signal, wherein the synchronization code detecting means detects the synchronization code at a plurality of periodically predetermined synchronization code inserting positions in the input code string.

Thus, in the case of the sixth coding/decoding system, since the coding system inserts the synchronization code into the multiplexed code string, which is obtained by multiplexing kinds of compressed codes, only at the periodically predetermined synchronization code inserting positions, the decoding system may carry out the synchronization detection only at the synchronization code inserting positions, so that the number of synchronization code detecting processes can be decreased in comparison with conventional systems for inserting a synchronization code into a code string at an optional position. In addition, in accordance with the decrease of the number of the synchronization code detecting processes, it is possible to decrease the probability that a pseudo synchronization occurs because of the bit string inputted to the decoding system changed to the same bit pattern as the synchronization code due to bit error. Therefore, according to the present invention, it is possible to decrease the number of the occurrences of the pseudo synchronization, so that the processing quantity in the synchronization code detection can be decreased.

(7) In a seventh coding system according to the present invention, code string transforming means is added to the sixth coding system. The code string transforming means transforms a code string other than said synchronization code, which is arranged at said synchronization code inserting position in said output code string, so that a humming distance from said synchronization code is equal to or greater than a predetermined value.

A seventh decoding system, according to the present invention, further comprises: code string transforming means for transforming a code string other than the synchronization code, which is transformed so that a humming distance from the synchronization code is equal to or greater than a predetermined value at the synchronization code inserting position of the input code string, into the original code string.

Thus, in the seventh coding/decoding system, in addition to the construction of the sixth coding/decoding system, the bit insertion in view of the error of the synchronization code, i.e., the transformation of the humming distance of the bit string arranged at the synchronization code inserting position from the synchronization code, is carried out, so that the same bit pattern as the synchronization code is contained in the bit code string. Therefore, it is possible to ensure that the error detection of the synchronization code does not occur with respect to an error of a supposed number of bits or less, so that it is possible to decrease the probability of the error detection of the synchronization code.

Furthermore, in the present invention, the synchronization code is a code string, which is inserted into a code string for synchronization recovery and which can be uniformly decoded. For example, if a code string for inserting a synchronization code is a multiplexed code string, which is obtained by multiplexing a plurality of kinds of compressed codes obtained by compression coding an image signal inputted for each frame, the synchronization code is a code representative of a partition of a coding frame, partitions of the plurality of kinds of compressed codes, and other partitions.

As described above, according to the present invention, the following advantages can be obtained.

(1) According to the first coding/decoding system, the synchronization codes are inserted only into the synchronization code inserting positions arranged at regular intervals, and the check bits of the error correcting-/detecting code are shifted so as to exist at positions other than the synchronization code inserting positions. Therefore, even if the same bit pattern as the synchronization code occurs in the check bit, the same pattern as the synchronization code does not occur at the synchronization code inserting position, and, in theory, there is no probability that synchronization is detected.

In addition, if the bit insertion into a code string at the synchronization code inserting position is carried out so as not to produce a pseudo synchronization code, it is possible to eliminate the difficulty in forming a code word so as not to produce the same bit pattern as the synchronization bit.

(2) According to the second coding/decoding system, in addition to the construction of the first coding system, the bit insertion is carried out in view of the synchronization code, i.e., the transforming process is carried out so that the humming distance from the synchronization code is equal to or greater than the predetermined value with respect to the bit string arranged at the synchronization code inserting position, and the decoding system carries out the backward transformation, so that the bit code does not contain the same bit pattern as the synchronization code. Therefore, it is possible to ensure to prevent the error detection of the synchronization code from occurring due to the errors of the supposed number of bits or less, so that the probability of the error detection of the synchronization code is decreased. In addition, if such transformation is carried out, it is possible to distinguish the synchronization code from the other code strings even if an error is mixed into the code string, so that the probability of the error detection of the synchronization code due to errors can be decreased.

Moreover, since the error correction/detection coding is carried out after the code word is transformed by the bit insertion, the error protection is carried out for the inserted bit. Therefore, in comparison with conventional systems for carrying out the bit insertion after the error correction/detection coding, the probability that an error occurs in the inserted bit is decreased. In addition, since the bit insertion is carried out only into the synchronization code inserting position, the increase of the quantity of cods due to the bit insertion is smaller than that in conventional systems for carrying out the bit insertion over the whole code string, so that the coding efficiency is improved.

(3) According to the third coding/decoding system, since the error correcting/detecting code immediately before the synchronization code is a degenerate code, it is possible to decrease the number of inserted bits for compensating the remainder of the information bit at the portion immediately before the synchronization code, to improve the coding efficiency, in comparison with conventional coding systems.

(4) According to the fourth coding/decoding system, the coding system utilizes the multiplexing rule in the high-effi-

ciency compression coding system, such as image and voice, and switches the error correcting/detecting code in accordance with the kind of the information of an input code string, and the decoding system determines the kind of the error correcting/detecting code on the basis of the decoded information to carry out the same switching as that of the coding system. Therefore, it is not required to add the header information representative of the kind of the error correcting/detecting code, and it is possible to assign the number of bits to high efficiency compression coding, such as image and voice, so that it is possible to improve the information quality, such as picture quality and sound quality.

(5) According to fifth coding/decoding system, the coding system transforms an input code string so that a humming distance in a synchronization code inserting interval as well as a humming distance in an interval of a predetermined number of bits before and after the synchronization code inserting interval are equal to or greater than a predetermined value, and the decoding system carries out the inverse transformation of the input code string, so that it is possible to prevent the same bit pattern as the synchronization code from being contained in this interval. Therefore, even if a bit string coded through a transmission line and/or a storage medium, which may cause a bit loss for losing a part of bit is lost and a bit addition for adding an excess bit, is transmitted/stored, if the number of lost/added bits is equal to or less than a predetermined number of bits, it is possible to distinguish a synchronization code from other code strings, so that the decoding system can correctly carry out the synchronization detection.

(6) According to the sixth coding/decoding system, since the coding system inserts synchronization codes only into synchronization code inserting positions periodically predetermined in a multiplexed code string, which is obtained by multiplexing kinds of compressed codes, the decoding system may carry out the synchronization detection only at the synchronization code inserting positions, so that the number of the synchronization code detecting processes can be decreased in comparison with conventional systems for inserting synchronization codes into a code string at optional positions.

In addition, since the probability that a pseudo synchronization occurs by the variation of the bit string inputted to the decoding system into the same bit pattern as the synchronization code, is decreased in accordance with the decrease of the number of the synchronization code detecting processes, it is possible to prevent the pseudo synchronization according to the present invention, so that the processing quantity for the synchronization code detection decreases.

(7) According to the seventh coding/decoding system, in addition to the construction of the sixth coding/decoding system, the bit insertion in view of the error of the synchronization code, i.e., the transformation of the humming distance of the bit string at the synchronization code inserting position from the synchronization code is carried out, so that the same bit pattern as the synchronization code is not contained in the bit string. Therefore, it is ensured that the error detection of the synchronization code does not occur with respect to errors of the supposed number of bits, so that the probability of error detection of synchronization codes can be decreased.

BRIEF DESCRIPTION OF THE DRAWINGS

FIG. 1 is a block diagram of the first and second preferred embodiments of a dynamic image coding system according to the present invention.

11

FIG. 2 is a diagram illustrating a multiplexing rule in a multiplexer of the dynamic image coding system of FIG. 1.

FIG. 3 is a block diagram of an output coding unit of the dynamic image coding system of FIG. 1.

FIG. 4 is a diagram illustrating an example of an output code string of the dynamic image coding system of FIG. 1.

FIG. 5 is a diagram illustrating an example of a synchronization code.

FIG. 6 is a block diagram of an error correction/detection switching coding part in the output coding unit of FIG. 3.

FIG. 7 is a block diagram of a code string assembling unit of the output coding unit of FIG. 3.

FIG. 8 is a block diagram of the first and second preferred embodiments of a dynamic image decoding system according to the present invention.

FIG. 9 is a block diagram of an input decoding unit of the dynamic image decoding system of FIG. 8.

FIG. 10 is a block diagram of a code string resolver of the input decoding unit of FIG. 9.

FIG. 11 is a diagram illustrating an example of a code string obtained by a conventional error correction-/detection switching coding system.

FIG. 12 is a diagram illustrating an example of a synchronization code, in which an error is caused by the addition/loss of a bit(s) in a transmission line, for explaining the second preferred embodiment of the present invention.

FIG. 13 is a diagram explaining the operation of a bit inserting unit of FIG. 3 in the second preferred embodiment.

FIG. 14 is a diagram explaining the operations of a synchronization detector and an inserted bit removing unit of FIG. 9 in the second preferred embodiment.

FIG. 15 is a diagram illustrating an example of a code string, in which a synchronization protection is carried out using a frame length information in the first and second preferred embodiments.

FIG. 16 is diagram illustrating another example of a code string, in which a synchronization protection is carried out using a frame length information in the first and second preferred embodiments.

FIG. 17 is diagram illustrating further example of a code string, in which a synchronization protection is carried out using a frame length information in the first and second preferred embodiments.

FIG. 18 is a block diagram of the third and fourth preferred embodiments of a dynamic image coding system according to the present invention.

FIG. 19 is a block diagram of an output coding unit of the third preferred embodiment of a dynamic image coding system according to the present invention.

FIG. 20 is a diagram illustrating an example of an output code string of the third preferred embodiment of a dynamic image coding system according to the present invention.

FIG. 21 is a block diagram of the third and fourth preferred embodiments of a dynamic image decoding system according to the present invention.

FIG. 22 is a block diagram of an input decoding unit of the third preferred embodiment of a dynamic image decoding system according to the present invention.

FIG. 23 is a block diagram of an output coding unit of the fourth preferred embodiment of a dynamic image coding system according to the present invention.

FIG. 24 is a block diagram of an input decoding unit of the fourth preferred embodiment of a dynamic image decoding system according to the present invention.

FIG. 25 is a block diagram of an example of an output code string of the fourth preferred embodiment of a dynamic image coding system according to the present invention.

12

FIG. 26 is a diagram illustrating a multiplexing rule in a multiplexer of a dynamic image coding system.

FIG. 27 is a block diagram of examples of output code strings of the fifth preferred embodiment of a dynamic image coding system according to the present invention.

FIG. 28 is a diagram illustrating other examples of multiplexing rules in a multiplexer of a dynamic image coding system.

FIG. 29 is a diagram of an output code string, in which synchronization codes are processed when the multiplexing shown in FIG. 28 is carried out.

FIG. 30 is a code table for explaining examples of stuffing bits used for the present invention.

FIG. 31 is a diagram explaining a process in a decoding system when the stuffing bits of FIG. 30 are used.

FIG. 32 is a diagram explaining the characteristics of the stuffing bits of FIG. 30.

FIG. 33 is a diagram of examples of output code strings when a synchronization code inserting interval is shorter than a synchronization code.

FIG. 34 is a diagram of examples of the use of synchronization codes of different lengths.

FIG. 35 is a diagram of examples of output code strings of the sixth preferred embodiment of a dynamic image coding system according to the present invention.

BEST MODE FOR CARRYING OUT THE INVENTION

Referring now to the accompanying drawings, the preferred embodiments of the present invention will be described below.

FIRST PREFERRED EMBODIMENT

FIG. 1 is a block diagram of the first preferred embodiment of a dynamic image coding system, according to the present invention, wherein a coding system having an error correcting/detecting code switching function of the present invention is combined with a high-efficiency compression coding system which uses a motion-compensated adaptive prediction and a discrete cosine transform coding serving as a kind of an orthogonal transform coding. A coding system comprising the combination of a motion-compensated adaptive prediction and a discrete cosine coding is detailed in, e.g., Literature 1 "International Standard of Multimedia Coding" by Hiroshi Yasuda, Maruzen (June 1991). Therefore, only the operation of the coding system will be schematically described. In addition, it is assumed that information bits are separated from detection bits in an error correcting/detecting code similar to a BCH code.

In FIG. 1, with respect to an input dynamic image signal **131** serving as an object to be coded, which is inputted for each frame, a motion-compensated adaptive prediction is first carried out for each small region, such as a macro block. That is, in a motion-compensated adaptive predictor **101**, a motion vector between an input dynamic image signal **131** and an image signal, which is stored in a frame memory **102** and which has been encoded and/or locally decoded, is detected, and a prediction signal **132** is produced by the motion-compensated prediction on the basis of the motion vector. In this motion-compensated predictor **101**, a prediction mode suitable for coding is selected from the motion-compensated prediction coding and the intraframe coding (prediction signal=0), which directly encodes the input dynamic image signal **131**, to produce the corresponding prediction signal **132**.

13

The prediction signal **132** is inputted to a subtracter **103**, wherein the prediction signal **132** is subtracted from the input dynamic image signal **131** to output a prediction residual signal **133**. The prediction residual signal **133** is discrete-cosine-transformed (DCT) in a discrete cosine transformer **104** for each block having a predetermined size to produce a DCT coefficient. The DCT coefficient is quantized by means of a quantizer **105**. The DCT coefficient data quantized by the quantizer **105** are divided into two parts, one of which is variable-length-encoded by means of a first variable length encoder **106**, and the other of which is inverse-quantized by means of an inverse quantizer **107** to be inverse-discrete-cosine-transformed (inverse DCT) by means of an inverse discrete cosine transformer **108**. The output of the inverse discrete cosine transformer **108** is added to the prediction signal **132** in an adder **109** to produce a locally decoded signal. This locally decoded signal is stored in the frame memory **102**.

On the other hand, the information on the prediction mode and the motion vector, which have been determined by the motion-compensated adaptive predictor **101**, is variable-length-encoded by means of a second variable length encoder **110**. The variable length codes (compressed codes) outputted from the first and second variable length encoders **106** and **110** are multiplexed by means of a multiplexer **111** to be outputted as a multiplexed code string **201**.

The multiplexer **111** outputs the multiplexed code string **201**, a FEC kind identifying signal **202** representative of the kind of an error correcting/detecting code corresponding thereto, and a synchronization code insertion request signal for requesting to insert a synchronization code. The code string **202**, the FEC kind identifying signal **202** and the synchronization code insertion request signal **203** are inputted to an output coding unit **200** for switching and encoding the code string **202** to kinds of error correcting/detecting codes of different error correcting-/detecting capabilities, to produce a final output code string **205**. In this preferred embodiment, the output coding unit **200** corresponds to a coding system according to the present invention.

FIG. **2** is a diagram illustrating a multiplexing flow in the multiplexer **111**. The multiplexing is carried out for each coding frame. First, a synchronization code **301** is multiplexed. When the synchronization code **301** is multiplexed, the synchronization code insertion request signal **203** is outputted from the multiplexer **111**, and the coding system **200** has notice that the multiplexed code word is a synchronization code. Then, picture headers **203** representative of various coding modes of the coding frame are multiplexed to be the multiplexed code string **201**. Then, a prediction mode information **303** representative of a prediction mode in a motion-compensated adaptive predictor MC in each region is multiplexed, and a motion vector information **304** and a DCT coefficient **305** of a predictive residual signal (hereinafter referred to as a "residual DCT coefficient") are multiplexed. When the picture header **302**, the prediction mode information **303**, the motion vector information **304** and the residual DCT coefficient **305** are multiplexed, the FEC kind identifying signals **202** representative of the kind of error correcting-/detecting codes corresponding thereto are outputted.

The error correcting/detecting codes of high correcting-/detecting capabilities are used for the picture header **302**, the prediction mode information **303** and the motion vector information **304**, which greatly deteriorate the picture quality if an error is mixed. On the other hand, if an error is mixed into the residual DCT coefficient **305**, it is possible to prevent the picture quality from greatly deteriorating by detecting the error and setting the residue to be zero. Therefore, the error

14

correcting capacity is not required to be high, and only the error detection may be carried out.

FIG. **3** is a block diagram of an output coding unit of FIG. **1**. The output coding unit **200** comprises a bit inserting unit **211**, an error correction/detection switching encoder **212** and a code string assembling unit **213**. FIG. **4** shows an example of an output code string **205** produced by the output coding unit **200**. In FIG. **4**, PSC denotes a synchronization signal, PH denotes a picture header, MODE denotes a prediction mode information, MV denotes a motion vector, CHK denotes a check bit of an error correcting-/detecting code, DOEF is a residual DCT coefficient, and STUFF denotes a stuffing bit (an inserted bit). This output code string **205** has the following characteristics.

(1) The synchronization codes PSC are inserted into only synchronization code inserting positions indicated by arrows, which are arranged at regular intervals (every sync_period bits). The length of the sync_period is set to be greater than the length of the synchronization code PSC and the maximum length of the check bit CHK. The check bit CHK is shifted so as to be arranged immediately before the synchronization code inserting position.

(2) The error correcting/detecting code at the end part of a frame, i.e., a synchronization period between a synchronization code PSC and the next PSC, is a degenerate code for encoding only the finally remaining information bit, and the stuffing bits STUFF having the number of bits required to displace the check bit CHK (CHK6 in the example of FIG. **4**) are inserted.

(3) The FEC kind identifying signal representative of the kind and number of the error correcting/detecting codes does not exist in the output code string **205** of FIG. **4**.

In this output code string **205**, since the check bit CHK is displaced as described in (1), no check bit CHK enters the synchronization code inserting positions indicated by the arrows, so that there is no probability that a pseudo synchronization is produced by the check bit CHK. In addition, in a case where the error correction/detection coding of the end of the frame is carried out as described in (2), it has been required to insert many inserted bits (dummy bits) in the prior art. However, in this preferred embodiment, since the end of the frame has the degenerate code, the number of inserted bits may be small. Moreover, as described in (3), since the header information representative of the kind and number of the error correcting/detecting codes are contained in the output code string **205**, the amount of codes is not increased therefor.

Comparing the multiplexed code string **201** of FIG. **2** outputted from the multiplexer **111** with the output code string **205** of FIG. **4**, the construction and operation of the output coding unit **200** of FIG. **3** for producing such an output code string **205** will be described in detail below.

When the synchronization code **301** is multiplexed in the multiplexer **111**, the synchronization code insertion request signal **203** is outputted as described above. For example, as shown in FIG. **5**, the synchronization code **301** comprises "0"s of sync_0_len bits, a "1" of one bit, and a "xxxxx" of sync_nb_len bits representative of the kind of the synchronization code **301**. The output coding unit **200** outputs a synchronization code (PSC) serving as an output code string **205** from the code string assembling unit **213** when receiving the synchronization code **301** and the synchronization code insertion request signal **203** from the multiplexer **111**.

As shown in FIG. **4**, since the synchronization code **301** can be inserted only at the synchronization code inserting positions arranged at intervals of sync_period bits, when the end of the output code string **205** produced is not arranged at the synchronization code inserting position, a stuffing bit

STUFF is inserted so that the synchronization code **301** is arranged at the synchronization code inserting position as described later.

After the synchronization code **301** is outputted to the output code string **205**, the picture header **302**, the prediction mode information **303**, the motion vector information **304** and the residual DCT coefficient **305** are encoded as follows. The bit insertion into the multiplexed code string **201** outputted from the multiplexer **111** is carried out to prevent a pseudo synchronization from occurring in the bit inserting unit **211**. That is, if the same bit pattern as the code word of the synchronization code **301** exists in the output code string **201**, the bit insertion is carried out, if necessary, in order to prevent the synchronization code **301** from being not able to be uniformly decoded. For example, in a case where the synchronization code **301** is a code word having continuous "0"s of sync_0_len bits as shown in FIG. 5, if a "1" is inserted so that "0"s of the sync_0_len bits or more do not continue in code strings other than the synchronization code **301**, it is possible to prevent a pseudo synchronization from being produced.

As described above, since the synchronization codes **301** are inserted only at the synchronization code inserting positions, the bit inserting operations for preventing the pseudo synchronization from occurring may be carried out only at the synchronization code inserting positions. Therefore, a counted value **221** representative of the total number of bits of the output code strings **205** produced is outputted from the code string assembling unit **213**, and it is determined by the bit inserting unit **211** on the basis of the counted value **221** whether the bit insertion is required. Assuming that the counted value **221**, i.e., the total number of bits of the output code strings **205** produced, is total_len , the number of "1"s in the multiplexed code string **201** is counted in an interval wherein $0 < \text{total_len} \bmod \text{sync_period} \leq \text{sync_0_len}$. If no "1" exists in this interval, a "1" of one bit is inserted. A mod B denotes a remainder when A is divided by B.

In addition, in order to decrease the probability of the error detection of the synchronization code **301**, the bit insertion may be carried out as follows.

In order to detect the synchronization code **301** even if an error of n bits is mixed into the synchronization code **301**, it is required to determine that a code word having a hamming distance of n or less from a true synchronization code in an input decoding unit of a dynamic image decoding system as described later is a synchronization code. However, if such a determination is carried out while the code strings other than the synchronization code **301** are as they are, bit patterns having a hamming distance of n or less from the synchronization code may exist even in the code strings other than the synchronization code **301**. Therefore, if this is arranged at the synchronization code inserting position, it may be erroneously determined to be the synchronization code **301**.

Therefore, the bit insertion into the multiplexed code string **201** is carried out by means of the bit inserting unit **211**, so that the code strings other than the synchronization codes arranged at the synchronization code inserting positions in the multiplexed code string **201** are transformed so as to have a hamming distance of $2*n+1$ or more from the synchronization code **301**. Specifically, the number of "1"s (assumed to be n_0) is counted in an interval wherein $0 < \text{total_len} \bmod \text{sync_period} \leq \text{sync_0_len} - (2*N+1)$. If n_0 is equal to or less than $2*n+1$, "1"s of $2*n+1-n_0$ bits are inserted into the multiplexed code string **201**.

Thus, a code string **222**, in which the bit insertion is carried out by means of the bit inserting unit **211**, together with the FEC kind identifying signal **202** representative of the kind of

an error correcting/detecting code, is inputted to the error correcting/detecting code switching encoding part **212**.

FIG. 6 is a block diagram of an error correcting-/detecting code switching encoding part **212**. A latch circuit **603** is a circuit for latching a FEC kind identifying signal **202**. When the output of a synchronization code from the multiplexer **111** to the multiplexed code string **201** is completed to stop the output of the synchronization code insertion request signal **203**, the latch circuit **603** latches the FEC kind identifying signal **202** to supply a latched signal **623** to an error correction/detection encoder **604**.

An error correction/detection encoder **604** carries out the error correction/detection coding of a code string **222**, which is outputted from a bit inserting unit **211**, on the basis of the latched signal **623** to output an information bit **631** and a check bit **632**. In addition, when the error correction/detection coding of one block is completed, the error correction/detection encoder **604** outputs a latch indicating signal **625**, which indicates the latch of the next FEC kind identifying signal **202**, to the latch circuit **603**. The latch circuit **603** latches in accordance with the latch indicating signal **625** to supply the latched signal **623** to the error correction/detection encoding **604**.

The aforementioned operation is repeated in the output coding unit **200**, so that the error correction/detection coding of the bit-inserted code string **222** outputted from the bit inserting unit **211** is carried out while switching the error correcting/detecting code in the error correction/detection switching encoder **212** on the basis of the FEC kind identifying signal **202** outputted from the multiplexer **111**. Since the FEC kind identifying signal **202** is latched by the latch circuit **603** only at the time that the coding of the error correcting/detecting code of one block is completed, the same error correcting/detecting codes are applied before this switching point. For example, in a case where the picture header **302** uses an error correcting/detecting code FEC1 and the prediction mode information **303** uses an error correcting/detecting code FEC2, if the number of bits of the picture header **302** is smaller than the number of information bits of one block of the FEC1, the FEC1 is used as the error correcting/detecting code of the subsequent prediction mode information **303** until the number of bits of the picture header **302** reaches the number of information bits of the FEC1.

FIG. 7 is a block diagram of a code string assembling unit **213** of FIG. 3. The code string assembling unit **213** comprises a counter **701** for counting the number of bits of the output code string **205**, a buffer **702** for temporarily storing the check bit **632** and the number of bits thereof, a switch **703** for switching the output code string **205**, and a switch controller **704** for controlling the switch **703**.

The counter **701** is reset to be a value of a synchronization code length sync_len when the synchronization code insertion request signal **203** is inputted, and counts up sequentially from the next bit of the synchronization code until the next synchronization code is inputted. The switch **703** is operated so that the information bit **631** is outputted before the initial check bit **632** is inputted after the synchronization code is inputted. When the check bit **632** is inputted, it is stored in the buffer **702** and the number of bits thereof (the number of check bits) **711** is outputted from the buffer **702** to the switch controller **704**.

The switch controller **704** controls the switch **703** on the basis of the number **711** of check bits and the counted value **221** of the counter **701** so that the check bit is displaced in order to prevent the check bit **632** from being outputted to the synchronization code inserting position as described above. For example, assuming the counted value **221** is bit_count

and the number 711 of check bits is $check_len$, the information bit 631 is outputted when $bit_count \bmod sync_period < sync_period - check_len$, and a check bit 713 stored in the buffer 702 is outputted when $sync_period - check_len \leq total_bits \bmod sync_period < sync_period$. Thereafter, the aforementioned process is repeated while the information bit 631 and the check bit 632 are inputted.

As described above, since the output coding unit 200 uses a degenerate code as an error correcting/detecting code at the end portion of one frame and performs the bit insertion to displace the check bit, it performs operation different from usual operations of portions other than the end portion. That is, when the output of the multiplexed code string 201 of one frame is completed, the multiplexer 111 outputs a synchronization code insertion request signal 203 for the next frame. In response thereto, the error correcting/detecting code 604 in the error correction/detection switching encoding part 212 of FIG. 6 performs the error correction/detection coding using a degenerate code, assuming that a shortage of the information bits 631 of the error correcting/detecting code is a predetermined bit pattern outputted from an inserted bit generator 705. This bit pattern may be a bit pattern wherein all bits are "1"s or "0"s, or may be a specific repeated pattern such as "0101 . . .". This compensated inserted bits are not outputted to the information bit 631.

In the code string assembling unit 213 of FIG. 7, after the information bit 613 is outputted to the end, the switch 713 is switched from the bit generator 705 to the input, and the inserted bits are inserted so that the check bit 713 stored in the buffer 702 is arranged immediately before the next synchronization code. Assuming that the counted value 221 of the counter 701 is $total_len$ when the last information bit 631 of one frame is outputted and that the number of the finally outputted check bits 632 is $last_check_len$, the number of inserted bits $stuffing_len$ is $stuffing_len = sync_period - last_check_len - (total_len \bmod sync_period)$. Furthermore, in a case where no degenerate code is used, it is required to insert $(into_len - last_into_len)$ bits, which is a shortage of the last information bit $last_into_len$ from the usual information bit $into_len$, and to insert a shortage of bits for displacing the check bit. Therefore, it is required to insert more inserted bits than those in the use of the degenerate code, by $into_len - last_into_len + (into_len - last_into_len) \bmod sync_period$.

Thus, after the code string assembling unit 213 outputs the information bits 631 and the inserted bits to the output code string 205 via the switch 703, and it finally outputs the check bit 713 to the output code string 205.

The first preferred embodiment of a dynamic image decoding system, according to the present invention, will be described below.

FIG. 8 is a block diagram of a dynamic image decoding system corresponding to the dynamic image coding system of FIG. 1. The output code string 205 outputted from the dynamic image decoding system of FIG. 1 passes through a transmission/storage system to be inputted to an input decoding unit 800 as an input code string 205'. In this preferred embodiment, the input decoding unit 800 corresponds to a decoding system of the present invention.

The input decoding unit 800 switches error correcting/detecting codes on the basis of a FEC kind identifying signal 802 representative of the kind of an error correction/detecting code outputted from a downstream demultiplexer 811, to output a code string 801, which has been error correction/detection encoded, a synchronization code detection signal 803 and an error detection signal 804. The demultiplexer 811 receives the code string 801, the synchronization code detection signal 803 and the error detection signal 804 to separately

output a prediction residual signal 841 and a motion-compensated adaptive prediction information code 842.

The prediction residual signal 841 and the motion-compensated adaptive prediction information code 842 are inputted to first and second variable length decoders 806 and 810, respectively. For a residual DCT coefficient 831 decoded by the first variable length decoder 806, a series of processes are carried out, i.e., the inverse quantization's carried out by means of an inverse quantizer 807 and the inverse discrete cosine transform is carried out by means of an inverse DCT unit 808. Then, the processed residual DCT coefficient is added to a motion-compensated adaptive prediction signal 832, which is an output of the motion-compensated adaptive predictor 801, in an adder 809 to be outputted as a reconstructed image signal 850. The reconstructed image signal 850 is outputted to the outside of the system and recorded in a frame memory 820. The motion-compensated adaptive prediction information decoded by the second variable length decoder 10 is inputted to the motion-compensated adaptive predictor 801 to produce the motion-compensated adaptive prediction signal 832.

The aforementioned processes are processes for producing a dynamic image so as to correspond to the dynamic image coding system of FIG. 1. The processes of the inverse quantizer 807, the inverse DCT unit 808, the adder 809 and the frame memory 820 are basically the same as those the inverse quantizer 107, the inverse DCT unit 108, the adder 109 and the frame memory 102 although the realizing means may be different. In addition, the processes in the first and second variable length decoders 806 and 810, the demultiplexer 811 and the input decoding unit 800 are inverse processes to those in the variable length encoders 106 and 110, the multiplexer 111 and the output coding unit 200, except for the case that an error is mixed into the code string.

FIG. 9 is a block diagram of the input decoding unit 800. The input decoding unit 800 comprises a synchronization detector 901 for detecting a synchronization code in the input code string 205', a counter 902 for counting the number of bits of the input code string 205', a code string resolver 903 for resolving a code string into information bits 912 and check bits 913, an error correction/detection decoder 904, and an inserted bit remover 905.

The synchronization detector 901 detects synchronization codes only at the synchronization code inserting positions on the basis of the counted value 911 of the counter 902. For example, assuming that the interval between the adjacent synchronization code inserting positions is $sync_period$, the counted value 911 is bit_count , and the length of the synchronization code is $sync_len$, the synchronization detection is carried out only when $0 < bit_count \% sync_period \leq sync_len$.

Furthermore, the synchronization code may be detected in view of errors in the synchronization code.

In the bit inserting unit 211 of the output coding unit of FIG. 3, if the code string is transformed by inserting bits so as to have a humming distance of $2*n+1$ or more from the synchronization code in view of errors of n bits or less, even if it is determined that the code string having a humming distance of n or less from a true synchronization signal is a synchronization code, error synchronization detection does not occur when the error of n bits or less is mixed.

FIG. 10 is a block diagram of the code string resolver 903. The input code string 205' is switched into information bits 1021 and check bits 913 by means of a first switch 1002 controlled by a controller 1001 which will be described later. When the information bits 1021 are outputted from the first switch 1002, an information bit length of the information bits

1021 are transmitted to a buffer 1004 via a second switch 1003 to be stored therein. A counter 1005 counts the number of output bits from the second switch 1003. A comparator 1006 compares a counted value 1023 of the counter 1005 with an information bit length 1024 outputted from an error correcting/detecting code information output unit 1007. When both are the same, the counter 1005 is reset, the FEC kind identifying signal 802 representative of the kind of an error detecting/correcting code is latched by means of a latch circuit 1008, and the buffer 1004 outputs the information bit 904. The output 914 of the latch circuit 1008 is inputted to the error correcting/detecting code information output circuit 1007, and outputted to the error correction/detection decoder 904 shown in FIG. 9.

As described above, the check bits of the error correcting/detecting code are displaced to be arranged between the information bits of the error correcting/detecting code after the code string 205. The controller 1001 controls so that the displaced check bits are separated from the information bits. When the input of the information bits of the error correcting/detecting code of one block is completed, the counted value 1023 corresponds to the information bit length 1024 in the comparator 1006. In response thereto, the controller 1001 receives a check bit length 1025 from the error correction/detection information output unit 1007, and calculates the positions of the check bits arranged between the next information bits. When it is determined by the comparator 1006 that both correspond to each other, assuming that the counted value 911 of the number of input bits of the code string 205' is bit_count and the check bit length is check_len, the check bit starting position check_start is $check_start = (bit_count / sync_period + 1) * sync_period - check_len$, and the check bit end position check_end is $check_end = (bit_count / sync_period + 1) * sync_period$. The controller 1001 controls the switch 1002 so that the check bits 913 are outputted from the check_start to the check_end of the counted value 911.

Since the end of one frame is a degenerate code and the error correction/detection encoding thereof is carried out, it is specially processed. When reaching the end of one frame, a signal 803 representative of the detection of the next frame is outputted. In response to this signal 803, the controller 1001 calculates the positions of the check bits of the last error correcting/detecting code of the frame and the number of insufficient bits of the information bits. It is assumed that the counted value 911 of the number of bits of the code string 205' inputted when starting to input the last error correcting/detecting code of one frame is pre_last_count, the counted value 911 when the input of the code string 205' of one frame is completed is total_count, the counted value 911 during the process is bit_count, the check bit length of the last error correcting/detecting code of one frame is last_check_len, and the check bit length of the error correcting/detecting code immediately before of the last error correcting/detecting code is pre_last_check_len. First, the excess and deficiency of information bits due to the error correcting code being a degenerate code and due to the insertion of bits is calculated. Among the information bits of the last error correcting/detecting code of one frame, the number of bits contained in the output code string 205, last_info_len, is $last_info_len = total_count - last_check_len - pre_last_count - pre_last_check_len$. When last_info_len is shorter than the information length of the error correcting code info_len, it is determined that the error correcting code is a degenerate code. In addition, when the counted value 1023 is in the range of from last_info_len to info_len, the switch 1021 is switched to a bit pattern outputted from an inserted bit generator 1015, to make-up for the deficiency of information bits due to

degeneracy. The output bit pattern from the inserted bit generator 1015 generates the same bit pattern as that of the inserted bit generator 705 of FIG. 7 of the encoder.

On the other hand, when last_info_len is longer than info_len, it is determined that the error correcting code is the inserted bit part, so that the information bits 912 are not outputted for the portion wherein the counted value 1023 is equal to or greater than info_len. With respect to the check bits, the switch 1002 is controlled so as to output, as check bits, the output code string 205 when $total_count - check_len < bit_count \leq total_count$.

The error correction/detection decoder 904 receives the information bits 912 and the check bits 913, which are outputted from the code string resolver 903, and decode the error correcting/detecting code on the basis of the FEC kind identifying signal 914 representative of the kind of the error correcting/detecting code latched by the latch circuit 1008 of FIG. 10, to output an error corrected code string 915 and an error detection signal 804.

The error corrected code string 915 is inputted to the inputted bit remover 905. The inserted bit remover 905 removes the inserted bits for preventing the pseudo synchronization signal inserted by the bit inserting unit 211 of the output coding unit 200. As described above, since the bit insertion is carried out only at the synchronization inserting position, the synchronization inserting position is determined on the basis of the counted value 911 of the counter 902.

For example, when the synchronization code word is that shown in FIG. 5 and when the bit inserting unit 211 inserts bits into the portion "0000..." of the first sync_len bits of the synchronization code so that the humming distance from the synchronization code is greater than $2*n+1$, the number of "1"s (=n0) of "sync_0_len-(2*n+1)" bits from the synchronization code inserting position is counted. When the n0 is equal to or less than $2*n+1$, $2*n+1-n0$ bits are removed. However, since it is determined that the inserted bit is "1", when the bit determined as the inserted bit by the inserted bit removing unit 905 is "0", it is considered that an error is mixed in the synchronization code inserting interval. In this case, the error detection signal 804 is outputted.

Thus, the code string 801 decoded by the input decoding unit 800 is inverse multiplexed by means of the demultiplexer 811. This is operation for separating and outputting the multiplexed code word as shown in FIG. 2. This inverse multiplexer 811 works with the first and second variable length decoders 806 and 810.

First, when the synchronization code detection signal 803 is inputted from the output decoding system 800, the demultiplexer 811 returns to the initial state of the frame process. Then, the kind of the error correcting/detecting code to the picture header is outputted as the FEC kind identifying signal 802 representative of the kind of the error correcting/detecting code, and the code string 801 is inputted to decode the picture header 302, so that it is determined whether there is no error in the picture header. When there is no error, the kind of the error correcting/detecting code to the prediction mode information 303 is outputted as the FEC kind identifying signal 802, and the code string 801 is inputted to demultiplex the prediction mode information to output it to the second variable length decoder 810.

When all the prediction mode information is decoded, the second variable length decoder 810 outputs a signal representative thereof to the demultiplexer 811. In response thereto, the demultiplexer 811 outputs a FEC kind identifying signal representative of the kind of an error correcting/detecting code to the motion vector information 304, and starts the demultiplexing of the motion vector information 304. The

demultiplexed motion vector information is outputted to the second variable length decoder **810** to be decoded. When the decoding of all the motion vector information is completed, a signal representative thereof is outputted from the second variable length decoder **810** to the demultiplexer **811**. In response thereto, the demultiplexer **811** outputs a FEC kind identifying signal representative of the kind of an error correcting/detecting code to the residual DCT coefficient, and demultiplexes the residual DCT coefficient **305** which is outputted to the first variable length decoder **806**.

As described above, the kind of the error correcting-/detecting code is determined on the basis of the multiplexing rule which is defined in the demultiplexer **811** so as to be the same as that of the output coding unit **200**. Therefore, the output code string **205** is not required to contain the header information representative of the error correcting/detecting code and so forth.

In the error correction/detection decoder **904**, it may be detected by the error detection code that an error is mixed in the input code string **205'**. In addition, as described above, an error of the inserted bits may be detected by the inserted bit removing unit **905**. In these cases, the error detection code **804** is outputted from the input decoding unit **800**. Moreover, when a code word, which does not exist in the variable length code word table, is detected in the variable length decoding process, it is determined that an error is mixed. In addition, when it is determined that a part is against the multiplexing rule in the demultiplexing process in the demultiplexer **811**, it is determined that an error is mixed. In these cases, the input decoding unit **800** and the demultiplexer **811** carry out the following processes so as not to greatly deteriorate the reconstructed image.

(1) When an error is detected in the residual DCT coefficient, the residue of the corresponding part is set to be 0. When an intra coding mode is selected as a prediction mode, the reconstructed image signal in the corresponding region may be predicted on the basis of the reconstructed image signal in the reconstructed frame and the surrounding region.

(2) In a case where an error is detected in the prediction mode information and the motion vector, when the prediction mode information and the motion vector information in the region, in which the error is detected, can be presumed on the basis of the prediction mode information and the motion vector information in the surrounding region, the presumed information are used. When it is impossible, the reconstructed image signal in the corresponding region is predicted on the basis of the reconstructed image signal in the reconstructed frame and the surrounding region.

(3) When an error is detected in a picture header, if the picture header is used as it is, there is probability that the picture quality is very greatly deteriorated. Therefore, the reconstructed image of the last frame is used as the reconstructed image of the current frame.

In the aforementioned processes (1), (2) and (3), when the error has the influence on the subsequent codes to the next synchronization code because of the use of the variable length coding, the same processes are carried out for that portion.

While it has been described that the synchronization code detector **901** detects synchronization codes only at the synchronization code inserting positions (at intervals of sync_period bits), the loss of bits and/or the insertion of error bits may occur in a transmission/storage medium. In such a case, the synchronization codes may be detected at positions other than the synchronization code inserting positions, and it may be determined that the positions, at which the synchronization codes are detected, are synchronization code inserting positions.

SECOND PREFERRED EMBODIMENT

Referring to FIGS. **12** through **14**, the second preferred embodiment of the present invention will be described below.

In this preferred embodiment, a dynamic image coding system and a dynamic image decoding system can surely detect synchronization even if a code string is transmitted/stored in a transmission line/storage medium in which the number of bits is decreased due to the loss of a part of a bit string or the number of bits is increased due to the addition of excessive bits.

FIG. **12** is a block diagram showing the principle of a process for detecting synchronization when such addition/loss of bits occurs. It is assumed herein that the right synchronization code comprises "0"s of sync_0_len bits and a "1" of one bit as shown in FIG. **12(a)**. Furthermore, in FIG. **12**, "x" denotes a bit other than a synchronization code.

FIGS. **12(b)** through **12(e)** show how the synchronization code is changed by the addition/loss of bits. It is assumed herein that the number of added/lost bits (Nid) is one bit at the maximum. FIG. **12(b)** shows that one bit is eliminated from a bit string before a synchronization code, so that the whole synchronization code is shifted forwards by the one bit. FIG. **12(c)** shows that one bit is added to a bit string before a synchronization code, so that the whole synchronization code is shifted backward by the one bit. FIG. **12(d)** shows that a bit is eliminated from a synchronization code, so that the bits after the bit eliminating position indicated by the arrow are shifted forward by one bit. Moreover, FIG. **12(e)** shows that one bit is added to a synchronization code at the bit adding position indicated by the arrow, so that the bits after the bit adding position are shifted backwards by the one bit.

In order to correctly detect synchronization even if the addition/loss of bits occurs, it is required to determine that the bit strings shown in FIGS. **12(b)** through **12(e)** are synchronization codes. As can be seen from FIG. **12**, the number of "1"s contained in the interval of $\pm Nid$ bits at the right synchronization code inserting positions is sync_0_len-3*Nid bits at the maximum. Therefore, synchronization may be detected in the interval of $\pm Nid$ bits at the synchronization code inserting positions on the decoding side, and if the number of "1"s contained in this range is less than the aforementioned value, it may be determined to be a synchronization code. In addition, in the coding system, code strings are transformed so that bit patterns of FIGS. **12(b)** through **12(d)** do not occur.

Mainly with respect to the difference from the first preferred embodiment, such coding/decoding systems will be described below.

The whole construction of the second preferred embodiment of a dynamic image coding system, according to the present invention, is the same as that of the first preferred embodiment of a dynamic image coding system, except for the operation of the bit inserting unit **211** of FIG. **3**. FIG. **13** shows the operation of the bit inserting unit **211**. That is, in the bit inserting unit **211** in the first preferred embodiment, the bit inserting operation is carried out only at the synchronization code inserting interval. On the other hand, in the bit inserting unit **211** in the second preferred embodiment, the bit insertion is carried out in a synchronization code inserting interval of $\pm Nid$ bits in order to prevent the same bit pattern as the synchronization code from being produced even if the addition/loss of Nid bits occurs at the maximum.

Assuming that the counted value **221** in FIG. **3** is total_len and the interval between the adjacent synchronization code inserting positions is sync_period, the bit inserting unit **221** counts the number of "1"s (assumed to be=n0) in the region of

total_len mod sync_period=sync_0_len-1-3*Nid on the basis of total_len mod sync_period=sync_period-Nid (mod: excess operation), and inserts "1"s of "3*Nid+1-n0" if n0 is less than 3*Nid+1.

FIG. 13 shows an example of the operation of the bit inserting unit 211 when sync_period=12, sync_0_len=9, and Nid=1. In this example, since n0=2, "1"s of 3*Nid+1-n0=2 bits are inserted.

By such bit insertion, it is ensured that the number of "0"s of $\pm Nid$ bits in the synchronization code inserting interval is equal to or greater than 3*Nid bits, so that it is possible to uniformly identify synchronization codes.

On the other hand, the whole construction of the second preferred embodiment of a dynamic image decoding system, according to the present invention, is the same as that of the first preferred embodiment, except for the operations of the synchronization detector 901 and the inserted bit remover 905 in FIG. 9. FIG. 14 shows the operation of an inserted bit remover 905.

That is, the synchronization detector 901 detects synchronization codes in the range of $\pm Nid$ bits before and after the synchronization code inserting position, in order to detect synchronization even if the addition/loss of Nid bits occurs at the maximum.

First, it is determined whether synchronization codes exist at every synchronization code inserting position. That is, assuming that the counted value 911 of the counter 902 is bit count, the number of "0"s (assumed to be=ns0) in the range of bit_count mod sync_period=sync_0_len-1+Nid is counted on the basis of bit_count mod sync_period=sync_period-Nid. When n0 is below 3*Nid, it is determined that a synchronization code exists in this region.

FIG. 14 shows operation when sync_period=12, sync_0_len=9, and Nid=1. In this example, the number of "0"s is counted in the range that (bit_count mod sync_period) is from "1" to "8". In the example of FIG. 14, since ns0=2, it is determined that a synchronization code exists.

Then, it is determined what bits the code string is shifted by the addition/loss of bits in the synchronization code inserting interval, in which it is determined that a synchronization code exists. In the case of sync_0_len bits shown in FIG. 14, the shifted amount from the position of the last "1" is determined. Specifically, after searching a "1" which first appears from the (sync_0_len+1 bits) th from the head of the synchronization code determining region, it is derived which bit the searched "1" is from the head of this synchronization code determining region (assuming that this is first_1_position bit). On the basis of the derived results, the shifted amount is derived from "the number of shifted bits=first_1_pos-(sync_0_len+1+Nid)" (forward shift in the case of negative, and backward shift in the case of positive). In the example of FIG. 14, since first_1_pos=10, the number of shifted bits=10-(9+1+1)=-1, so that it is found that the code string is shifted forward by one bit.

Unlike the first preferred embodiment, in the inserted bit remover 905, the inserted bit removing process is carried out in the interval of $\pm Nid$ bits before and after the synchronization code inserting position. That is, on the basis of bit_count mod sync_period=sync_period-Nid, the number of "1"s (assumed to be=n0) is counted in the region of bit_count mod sync_period=sync_0_len-1-3*Nid. When the n0 is equal to or less than 3*Nid+1, the "1"s of 3*Nid+1-n0 bits are removed.

In the second preferred embodiment, if the region, in which the addition/loss of bits occurs in a transmission line or a storage medium, can be determined by some method, the synchronization detecting process, the bit inserting process

and the bit removing process, which consider the addition/loss of bits, may be carried out only in that region.

Furthermore, also in the dynamic image decoding system in the first preferred embodiment as described above, the synchronization detection corresponding to the addition-/loss of bits in a transmission line and/or a storage medium is carried out. Therefore, the synchronization detector 901 may detect synchronization in the synchronization code inserting interval, i.e., in the interval of $\pm Nid$ bits, similar to the second preferred embodiment. In this case, although a pseudo synchronization, which is erroneously determined to be a synchronization code while being a portion other than the synchronization code, may be produced, it is possible to inhibit the quality of a reproduced image from being deteriorated due to synchronization detection error in a transmission line and/or a storage medium which tends to cause the addition/loss of bits, so that the picture quality can be improved.

In addition, if the region, in which the addition/loss of bits occurs in a transmission line and/or a storage medium, can be determined by some process, that process may be carried out only in that region, and a usual synchronization detection may be carried out in other regions.

Moreover, in the first and second preferred embodiments as described above, the synchronization may further protected using information representative of the length of a frame (which will be hereinafter referred to as a "frame length information"). FIGS. 15, 16 and 17 show examples of code strings using a frame length information POINTER.

In the example of FIG. 15, a frame length information POINTER and a check bit CHKP of an error correcting/detecting code for protecting the frame length information POINTER are arranged immediately after a synchronization code PSC. The number of bits of the last frame, i.e., information representative of the number of bits from the synchronization code of the last frame to the synchronization code of the current frame, is stored in the frame length information POINTER.

The coding system counts the number of bits a code string of one frame to transform the counted number into a frame length POINTER, and carries out the error correction-/detection encoding to produce a check bit CHKP. Then, as shown in FIG. 15, the coding system produces a code string immediately after the synchronization code of the next frame.

On the other hand, after the decoding system detects synchronization codes by the same method as those in the first and second preferred embodiments, it takes the subsequent frame length information POINTER and the check bit CHKP out of the code string, and carries out the error correction/detection decoding to decode the frame length information POINTER. Then, the decoded frame length information POINTER is compared with a value derived by counting the number of bits from the last detected synchronization code to the current synchronization code (frame length counted value), to check whether there is no error detection of synchronization codes.

If the frame length counted value is different from the code length of the last frame indicated in the frame length information POINTER, there is probability that a synchronization code is erroneously detected, so that the erroneously detected synchronization code is detected again using the frame length information POINTER. That is, it is assumed that a synchronization code, which could not be detected, exists before the current synchronization code by the number of bits indicated by the frame length information POINTER. In this case, the interval between the last detected synchronization code and the current synchronization code is divided into two frames, i.e., the interval between the last synchronization

25

code and the position indicated by the frame length information POINTER, and the interval between the position and the current synchronization code, to carry out the decoding process.

However, if the number of bits indicated by the frame-length information POINTER is greater than the number of bits from the last detected synchronization code to the current synchronization code, it is assumed that the frame length information POINTER is erroneous, so that the aforementioned synchronization re-detecting process is not carried out.

If the numbers of bits of the frame length information POINTER and the check bit CHKP are great, the synchronization code PSC, the frame length information POINTER, and the check bit CHKP may extend in a plurality of synchronization intervals as shown in FIG. 16. In this case, the bit inserting process in the coding system and the bit removing process in the decoding system, which are performed in order to maintain a constant humming distance between a code string other than a synchronization code and the synchronization code, may not be carried out in an interval in which the frame length information POINTER and the check bit CHKP exist.

In the examples of FIGS. 15 and 16, in a case where the end half of a synchronization code PSC contains information representative of the kind of the synchronization code (the distinction between a frame synchronization code, a GOB synchronization code and so forth), the frame length information POINTER is not only protected, but the end half of the synchronization code PSC may be also protected by an error correcting code. Thus, since the kind of a synchronization code can be accurately detected in addition to the position of the synchronization code, the resistance to errors can be further improved.

In the example of FIG. 17, a frame length information POINTER and a check bit CHKP are arranged at the end of a frame (immediately before a synchronization code in the next frame). In this case, after the decoding system detects the synchronization code in the next frame, it takes out a frame length information POINTER and a check bit CHKP immediately before the detected synchronization code to carry out the error correction/detection decoding, to carry out the re-detection of the synchronization code by the same processes as those of FIGS. 15 and 16.

In the example of FIG. 15, since the synchronization codes exist only at the synchronization code inserting positions, the frame length information POINTER to be recorded may be a value derived by dividing the number of bits of the frame by a synchronization code inserting interval (=sync_period bits). Thus, the frame length can be indicated by a smaller number of bits.

In addition, in the first and second preferred embodiments, while there has been shown examples of a hierarchical coding for changing an error correcting/detecting code in accordance with the importance of the coded information, the same error correcting/detecting code may be used in the frame, or no error correcting/detecting code may be used. In such cases, it is possible to improve the capability to detect synchronization in comparison with conventional systems, by using the bit inserting process for maintaining a code string other than a synchronization code at a humming distance greater than a predetermined value from the synchronization code, and the synchronization code detecting process corresponding to the bit inserting process, as described in this preferred embodiment.

In addition, in the aforementioned preferred embodiments, while it has been shown that a dynamic image signal is high-efficiency compression encoded to be transmitted/stored, the

26

present invention may be applied to the transmission/storage of a static image, voice, data or the like. For example, when the high-efficiency compression coding of a static image signal is carried out using the orthogonal transform, the error correcting-/detecting code may be switched so as to more strongly carry out the error protection of a low component of a transform coefficient. In the method for modeling and encoding voice into a driving source and a vocal tract filter, the error correcting/detecting code may be switched so as to more strongly carry out the error protection of a pitch cycle, a vocal tract parameter and so forth.

THIRD PREFERRED EMBODIMENT

The third preferred embodiment of the present invention will be described below. In this preferred embodiment, the error correcting/detecting code is not used. At this point, this preferred embodiment is different from the first and second preferred embodiments.

FIG. 18 is a block diagram of a dynamic image coding system in this preferred embodiment. Using the same reference numbers as those in FIG. 1 for the parts corresponding to those in FIG. 1, the different points from the first preferred embodiment will be mainly described. In this preferred embodiment, the construction and operation of an output coding unit 200 are different. In addition, although the basic operation of a multiplexer 111 is the same as the multiplexer 111 of FIG. 1, the multiplexer 111 in this preferred embodiment outputs only a multiplexed code string 201 and a synchronization code insertion request signal 203 since the error correcting-/detecting code is not used.

FIG. 19 is a block diagram of the output coding unit 200 of FIG. 18. The output coding unit 200 comprises a counter 1701 for counting the number of bits of an output code string 205, a switch 1703 for switching the output code string 205, a switch controller 1704 for controlling the switch 1703, and a stuffing bit generator 1705 for generating stuffing bits.

FIG. 20 shows an example of an output code string 205 generated by the output coding unit 200 of FIG. 19. The same signs as those in FIG. 4 are used for code words corresponding to those of the output code string of FIG. 4. Similar to FIG. 4, each of synchronization codes PSC is inserted only at any one of synchronization code inserting positions, which are arranged periodically, i.e., at regular intervals (sync_period bits) and which are indicated by arrows. FIG. 20 does not contain the check bit CHK for the error correcting/detecting code. At this point, FIG. 20 is different from FIG. 4. A stuffing bit STUFF is inserted into the end part of one frame of the output code string 205 so that a synchronization code PSC is inserted at the synchronization code inserting position. The number of bits of the stuffing bit STUFF is equal to or less than sync_period.

The construction and operation of the output coding unit 200 of FIG. 19 for producing such an output code string 205 will be described in detail below.

The counter 1701 is set to be "1" when a synchronization code insertion request signal 203 is inputted from a multiplexer 111 thereto and an initial bit of a synchronization code 301 is inputted thereto as a multiplexed code string 201, and it is set to be a synchronization code length sync_len when all the bits of the synchronization code 301 are inputted thereto. Thereafter, the counter 1701 counts up sequentially from the next bit of the synchronization code 301 until a bit immediately before the next synchronization code is outputted.

When bits from the initial bit of the synchronization code to the bit before the next synchronization code are inputted as a multiplexed code string 201, The switch controller 1704 con-

trols the switch 1703 so as to switch the switch 1703 to the multiplexed code string 201 to output the multiplexed code string 201 as an output code string 205.

Then, at the last part of one frame, the bit insertion (bit stuffing) is carried out so that the next synchronization code is inserted at the synchronization code inserting position. The multiplexer 111 output a synchronization code insertion request signal 203 for the next frame when the output of the multiplexed code string 201 of one frame is completed. In response thereto, the switch controller 1704 switches the switch 1703 to the stuffing bit generator 1705 to output a stuffing bit 1223 as an output code string 205. The stuffing bit 1223 may have all the bits of "1" or "0", or a specific pattern such as "0101 . . .".

This preferred embodiment of a dynamic image decoding system, according to the present invention, will be described below.

FIG. 21 is a block diagram of a dynamic image decoding system corresponding to the dynamic image coding system of FIG. 18. Using the same reference numbers as those in FIG. 8 for parts corresponding to those in FIG. 8, the different points from the first preferred embodiment will be mainly described. In this preferred embodiment, the construction and operation of an input coding system 800 are different from those in the first preferred embodiment. In addition, signals inputted from the input decoding unit 800 to a demultiplexer 811 are only a code string 801 and a synchronization code detection signal 803, and no signal is inputted from the demultiplexer 811 to the input decoding unit 800.

FIG. 22 is a block diagram of the input decoding unit 800. The input decoding unit 800 comprises a synchronization detector 1901 for detecting a synchronization code in an input code string 205', and a counter 1902 for counting the number of bits of the input code string 205'.

The counter 1902 is reset to be "0" at the initial stage of decoding, and counts up a counted value 1911 for each "1" every time one bit of the input code string 205' is inputted.

The synchronization detector 1901 detects synchronization codes only at the synchronization code inserting positions on the basis of the counted value 1911 of the counter 1902. For example, assuming that the synchronization code inserting interval is sync_period, the counted value 1911 is bit_count, and the length of the synchronization code is sync_len, the synchronization detection is carried out only when $0 < \text{bit_count} \bmod \text{sync_period} \leq \text{sync_len}$, wherein $A \bmod B$ denotes a remainder when A is divided by B. The synchronization detector 1901 outputs a synchronization code detection signal 803 when a synchronization code is detected.

The code string 801 from the input decoding unit is inputted to the multiplexer 811 while the input code string 205' is outputted as it is. Thereafter, similar to the dynamic image decoding system of FIG. 21, the demultiplexing and decoding processes are carried out.

In a case where the last stuffing bit STUFF of the frame is a predetermined bit pattern, it is determined whether the stuffing bit STUFF corresponds to a predetermined pattern in the demultiplexer 811. When it does not correspond thereto, it is determined that there is an error in the input code string 205', so that the process for preventing the picture quality from being greatly deteriorated, which has been described with respect to the dynamic image coding system in the first preferred embodiment, may be carried out.

The fourth preferred embodiment of the present invention will be described below.

In this preferred embodiment, the whole construction of a dynamic image coding system is the same as that of the dynamic image coding system of FIG. 18, and the operation of an output coding unit is different from that in the third preferred embodiment.

FIG. 23 is a block diagram of an output coding unit 200 in FIG. 18. Using the same reference numbers for parts corresponding to those of the output coding unit of FIG. 19, the difference from the output coding unit of FIG. 19 is that a bit inserting unit 1211 for carrying out the bit stuffing process for preventing a pseudo synchronization code is added.

In the bit inserting unit 1211, the bit insertion for preventing a pseudo synchronization for occurring is carried out for the multiplexed code string 201. Since it is not possible to uniformly decode a synchronization code if the same bit pattern as the synchronization code is contained in the output code string 205, the bit insertion is carried out in order to prevent this. For example, as shown in FIG. 5, when the synchronization code comprises "0"s of sync_0_len bits, a "1" of one bit and "xxxxx" of sync_nb_len bits representative of the kind of the synchronization code, it is possible to prevent a pseudo synchronization from occurring if a "1" is inserted so that "0"s of sync_0_len bits or more are not continuously arranged in the code string other than the synchronization code.

The synchronization code is inserted only into the synchronization code inserting system. Therefore, the bit inserting operation for preventing the pseudo synchronization from occurring may be carried out only at the synchronization code inserting positions. Thus, it is determined whether it is required to carry out the bit insertion on the basis of a counted value 1221 representative of the total number of bits of an output code string 205. Assuming that the counted value 1221 is total_len, the number of "1"s in the multiplexed code string 201 is counted in an interval of $0 < \text{total_len} \bmod \text{sync_period} \leq \text{sync_0_len}$. If no "1" exists in this interval, a "1" of one bit is inserted. Herein, $A \bmod B$ denotes a remainder when A is divided by B.

In addition, in order to decrease the probability of the error detection of a synchronization code due to error, the bit insertion may be carried out as follows.

In order to detect a synchronization codes even if an error of n bits is mixed into the synchronization code, it is required to determine that a code word having a hamming distance of n or less from a true synchronization code in an input decoding unit of a dynamic image decoding system as described later is a synchronization code. However, if such a determination is carried out while the code strings other than the synchronization code are as they are, bit pattern having a hamming distance of n or less from the synchronization code may exist even in the code strings other than the synchronization code. If this is arranged at the synchronization code inserting position, it may be erroneously determined to be the synchronization code.

Therefore, the following bit insertion into a multiplexed code string 201 is carried out by means of a bit inserting unit 211, so that the code strings other than the synchronization codes arranged at the synchronization code inserting positions in the multiplexed code string 201 are transformed so as to have a hamming distance of $2 \times n + 1$ or more from the synchronization code. Specifically, the number of "1"s (assumed to be n0) is counted in an interval in which $0 < \text{total_len}$

$\text{mod } \text{sync_period} \leq \text{sync_0_len} - (2 \times N + 1)$. If n_0 is less than $2 \times n + 1$, "1"s of $2 \times n + 1 - n_0$ bits are inserted into the multiplexed code string **201**.

With respect to a code string **1222**, in which the bit insertion has been thus carried out, the bit insertion (STUFF in FIG. **20**) is carried out in the last interval of the frame similar to the output coding unit of FIG. **19**, to be outputted as an output code string **205**.

This preferred embodiment of a dynamic image decoding system, according to the present invention, will be described below. The whole construction of this dynamic image decoding system is the same as that of the dynamic image decoding system of FIG. **21**, and the operation of an input coding system **800** thereof is different from that in the third preferred embodiment.

FIG. **24** is a block diagram of an input decoding unit **800**. Using the same reference numbers for parts corresponding to those of an input decoding unit of FIG. **22**, the difference between this preferred embodiment and the third preferred embodiment will be mainly described. In this preferred embodiment, a bit removing unit **1905** is added.

An input code string **205'** is inputted to an inserted bit remover **1905**, and a process for removing inserted bits is carried out in order to prevent a pseudo synchronization code inserted by a bit inserting unit **1211** of the output coding unit of FIG. **23**. As described above, since the bit insertion is carried out only at the synchronization code inserting positions, the synchronization code inserting positions are determined on the basis of a counted value **1911** of a counter **1902**.

For example, assuming that the synchronization code is a code word shown in FIG. **5** and when the bit inserting unit **1211** carries out the bit insertion into the initial portion "0000 . . ." of the synchronization code so that the humming distance from the synchronization code is greater than $2 \times n + 1$, the number of "1"s of $\text{sync_0_len} - (2 \times n + 1)$ bits from the synchronization code inserting position is counted. When the n_0 is less than $2 \times n + 1$, $2 \times n + 1 - n_0$ bits are removed.

Since it is determined that the inserted bit is "1", when the bit determined to be the inserted bit is "0", it is considered that an error is mixed in the synchronization code inserting interval. In this case, an error detection signal (not shown) may be outputted to a demultiplexer **811**, and the same process as that in the first preferred embodiment may be carried out so as to prevent a reproduced image from being greatly deteriorated.

The bit inserting process by the bit inserting unit **1211** of FIG. **23** may be carried out so that the inserted bits of a predetermined number of bits are inserted into all the synchronization code inserting intervals other than the synchronization code. FIG. **25** shows an example of an output code string **205** when such a bit inserting process is carried out. In the drawing, SB denotes an inserted bit.

For example, as shown in FIG. **5**, when a synchronization code comprises "0"s of sync_0_len bits, a "1" of one bit and "xxxx" of sync_nb_len bits representative of the kind of the synchronization code, an inserted bit SB of one bit is inserted at a predetermined position of an interval of sync_0_len bits from the head of the synchronization code inserting interval.

The inserted bit SB may be always "1". In addition, in accordance with a bit pattern in an interval of sync_0_len bits from the head of the synchronization code inserting interval, the inserted bit SB may be suitably determined so that the number of "1"s in the interval is equal to or greater than 1.

Moreover, the inserted bit SB may be an odd parity in an interval of sync_0_len bits from the head of the synchronization code inserting interval, to prevent the same bit pattern as the synchronization code from occurring and to detect an error mixed into this bit pattern.

FIG. **25(b)** shows an example of an output code string, in which such a bit inserting process is carried out. In this example, an inserted bit SB of 1 bit is inserted into the initial portion from the synchronization code inserting position. This inserted bit SB is determined so that the number of "1"s in an interval of the inserted bit SB and $\text{sync_0_len} - 1$ bits from the next bit is always an odd number. For example, in the left example of FIG. **25(b)**, the inserted bit SB is "1". In addition, in the right example of FIG. **25(b)**, since the inserted bit SB is "1" even if all the bits are "0" in the interval of $\text{sync_0_len} - 1$ bits from the next bit to the inserted bit SB, "1"s of 1 bit or more always exist in the synchronization code inserting interval, so that the same bit pattern as the synchronization code is not produced. In addition, since the inserted bit SB serves as a parity check, it is possible to detect a bit error mixed into this interval.

In addition, the inserted bit SB may be an odd parity check bit for all the bits before the next synchronization code inserting position. However, in order to prevent the same bit pattern as the synchronization code from occurring only when all of $\text{sync_0_len} - 1$ bits from the next bit to the inserted bit SB are "0", the inserted bit SB is always set to be "1". Thus, it is possible to carry out the error detection by the parity check of all bits.

In order to decrease the probability of the error detection of a synchronization code due to error, it is desired to insert more bits. For example, in order to correctly detect synchronization even if an error of n bits is mixed, "1"s of $2 \times n + 1$ bits are inserted into a predetermined position in this interval.

In this preferred embodiment, the operation of the bit removing unit **1905** of FIG. **24** is different so as to correspond to the operation of the aforementioned bit inserting unit **1211**. That is, the bit removing unit **1905** removes the inserted bit SB at a predetermined position, at which the bit insertion has been carried out by the bit inserting unit **1211**.

In a case where the inserted bit SB is always "1", it is determined that a bit error exists when a bit at the bit inserting position in the input code string **205'** is "0", so that an error detection signal (not shown) may be outputted to the inverse multiplexer **811** so as to prevent a reproduced image from being greatly deteriorated.

In the first through fourth preferred embodiments, while the prediction mode information **303**, the motion vector information **304** and the residual DCT coefficient **305** have been multiplexed in the multiplexer **111** for each coding frame as shown in FIG. **2**, the prediction mode information **303**, the motion vector information **304** and the residual DCT coefficient **305** may be multiplexed for each coding region (e.g., a macro block, GOB) as shown in FIG. **26**. In this case, the picture header **302** and the other information may have different error correcting/detecting code, or the same error correcting/detecting code. Alternatively, an error correcting/detecting code may be used for only the picture header or for a part of a code string of a predetermined number of bits of each frame, or no error correcting/detecting code may be used.

In addition, the multiplexing may not be carried out only for each frame (picture), but it may be also carried out for each part of a frame or for each layer of a plurality of frames, so that a synchronization code may be inserted for each of these multiplexing units (layer unit).

FIG. **28** shows examples of such multiplexing. In the examples of FIG. **28**, the multiplexing processes are carried out for each of four layers, i.e., each macro block layer of a plurality of coding blocks, each GOB layer of a plurality of macro blocks, each picture (frame) layer, and each session layer of a plurality of pictures. Among these layers, the session, picture and GOB layers use their synchronization sig-

31

nals (SSC, SEC, PSC and GSC in the drawing), respectively. Different codes are used for the SSC, SEC, PSC and GSC so that it is possible to identify which layer the synchronization code is detected. When the synchronization code shown in FIG. 5 is used, these synchronization codes may be distinguished by the portion of sync_nb_len bits representative of the kind of the synchronization code.

Also when such multiplexing is carried out, the same processes as those for the frame synchronization code in the preceding preferred embodiments may be carried out for a part or all of the synchronization codes of the session, picture or GOB. FIG. 29 shows an example of an output code string, in which such a process is carried out. As shown in FIG. 29, stuffing bits STUFF are inserted before the PSC and the GSC, and the SSC, PSC and GSC are inserted at the synchronization code inserting positions indicated by arrows in the drawing. Therefore, similar to the afore-mentioned preferred embodiment which shows the frame synchronization code PSC, the detection accuracy of each synchronization code can be improved.

The same length information as the frame length information POINTER of FIGS. 15, 16 and 17 may be added to each synchronization code of the session, picture and GOB. In a case where the frame length information POINTER is protected by the error correcting/detecting code as shown in FIGS. 15 and 16, if the error correcting/detecting code is not used only for the frame length information POINTER, but it is also used for a portion of sync_nb_len bits representative of the kind of a synchronization code, it is possible to improve the probability that the kind of the synchronization code, in addition to the position thereof can be correctly detected. In addition, a part or all of the header information (SH, PH and GF in the drawing) of the session, picture and GOB may be protected using the error correcting/detecting code, so that it is possible to improve the error resistance of each header information.

In a case where the stuffing process for preventing a pseudo synchronization code is carried out as this preferred embodiment, the following process may be carried out so that the synchronization code inserting interval sync_period is equal to or less than the length of the synchronization code.

First, the process in the output coding unit of the dynamic image coding system will be described. It is assumed herein that the synchronization code is a code word comprising "0"s of sync_0_len bits and a "1" of 1 bit as shown in FIG. 5. In the output coding unit of FIG. 23, assuming that the counted value 1221 representative of the number of bits outputted from the bit inserting unit 1211 is total_len, when a remainder of division of total_len by the synchronization code inserting interval sync_period is equal to a remainder of division of a value, which is derived by subtracting 1 from the number of bits sync_0_len of the initial "0" of the synchronization code, by sync_period, i.e., when

$$\frac{\text{total_len mod sync_period}=(\text{sync_0_len}-1) \text{ mod sync_period}}{\text{sync_period}} \quad (1)$$

the number of "1"s (assumed to be n1) in the output bits before (sync_0_len-1) bits from the output bit at that time is counted, and a "1" of 1 bit is inserted if no "1" exists (i.e., if n1=0).

FIG. 33(a) shows an example of an output code string, for which such a process has been carried out. In the drawing, each of downward arrows indicates a synchronization code inserting position, and a synchronization code comprises "0"s of 23 bits (i.e., sync_0_len=23), and a "1" of 1 bit. In the shown example, a synchronization code inserting interval

32

sync_period is 8, which is shorter than the length of the synchronization code (=24 bits).

In the drawing, intervals 1 through 4 denote intervals for counting the aforementioned n1. In each interval, the number of "1"s n1 is sequentially counted. If n1=0, a stuffing bit is inserted into the next bit of the interval. Since n1>0 in interval 1, it is not required to insert the stuffing bit. Since n1=0 in interval 2, a stuffing bit 3301 of 1 bit is inserted into the next interval. In interval 3, n1=1 due to the inserted stuffing bit 3301, so that it is not required to insert a stuffing bit.

If such a bit stuffing process is carried out, the same bit pattern as a synchronization code does not exist at a portion other than the synchronization code in an output code string, so that no pseudo synchronization occurs.

On the other hand, in order to decrease the probability that a synchronization code is erroneously detected due to transmission line error, a bit insertion may be carried out as follows.

Even if an error of n bits enters a synchronization codes the synchronization code can be correctly detected by carrying out a bit inserting process so that a humming distance between a portion other than the synchronization code and the synchronization code in an output code string in a bit insertion 1211 is equal to or greater than 2×n+1.

In this process, when a remainder derived by dividing a counted value 1221 total_len representative of the total number of bits of the output code string 205 of FIG. 23 by a synchronization code inserting interval sync_period is coincident with a remainder derived by dividing a value, which is derived by subtracting 2×n+1 from the initial number of bits of "0"s of a synchronization code, by sync_period, i.e., when

$$\frac{\text{total_len mod sync_period}=(\text{sync_0_len}-(2 \times n+1)) \text{ mod sync_period}}{\text{mod sync_period}} \quad (2)$$

the number of "1"s (assumed to be n1) in output bits of (sync_0_len-(2×n+1)) bits from the output bit at that time. If the number of "1"s is less than (2×n+1) bits, i.e., if n1<2×n+1, "1"s of (2×n+1-n1) bits are inserted.

As shown in FIG. 5, when a synchronization code starting from "0"s of a plurality of bits is used, if the number of "1"s in a bit string immediately before the synchronization code is insufficient, a synchronization error detection may occur at that portion. In order to prevent this, a bit insertion (STUFF in FIG. 20) in the last interval of a frame may be outputted so that the number of bits of "1"s in an interval of sync_period bits from the synchronization code to the synchronization code inserting position immediately before the synchronization code is equal to or greater than 2×n+1 bits.

In order to do this, a STUFF always containing "1"s of 2×n+1 bits may be used, or the STUFF may be determined in accordance with an output code string. That is, the STUFF may be determined so that the number of bits of "1"s of sync_period bits immediately before the synchronization code in the output code string containing the STUFF is equal to or greater than 2×n+1 bits.

FIG. 33(b) shows an example of an output code string, for which such process has been carried out. In the drawing, intervals 1 through 4 denote intervals for counting the aforementioned n1. In each interval, the number of "1"s n1 is sequentially counted. If n1<2×n+1, a stuffing bit is inserted into the next bit of that interval. Since n=1 in interval 2, stuffing bits 3311 of (2×n+1)-1=2 bits are inserted into the next interval. In interval 3 n1=3 due to the inserted stuffing bits 3311, so that it is not required to insert stuffing bits.

Moreover, in order to prevent a synchronization code error detection immediately before a synchronization code, a

STUFF is determined as follows. It is assumed that a bit immediately before the STUFF is **3311**. Since the number of “1”s in an interval (interval 5) of sync_period bits from a synchronization code inserting position immediately before the bit **3312** to a synchronization code inserting position immediately after the bit **3312** is only 1 bit, a synchronization error detection may occur in this portion if the synchronization code has a plurality of “0” continuously arranged as shown in FIG. 5. Therefore, the position, at which the synchronization code is inserted, is shifted to the next synchronization code inserting position, and a STUFF **3313** containing many “1”s is outputted. Thus, since “1”s of $2 \times n + 1$ or more are contained in an interval (interval 6) of sync_period bits immediately before the synchronization code, it is possible to prevent the synchronization error detection.

If such a bit stuffing process is carried out, the humming distance from the synchronization code can be $2 \times n + 1$ or more at a portion other than the synchronization code in the output code string, so that the probability of the synchronization error detection can be decreased.

Processes in an output decoding system of a dynamic image decoding system will be described below. In the bit remover **1905** of FIG. 24, assuming that the counted value **1905** representative of the number of bits of an input code string is total_len, and when the total_len meets the conditions in which it is 1, the number of “1”s (assumed to be n1) in input bits of (sync_0_len-1) bits from the input bit at that time is counted. If no “1” exists, i.e., if $n1 = 0$, 1 bit is removed.

In order to detect a synchronization code even if an error of n bits is mixed into the synchronization code, in a case where a bit inserting process is carried out by the bit inserting unit **1211** so that the humming distance between a portion other than the synchronization code and the synchronization code in an output code string is equal to or greater than $2 \times n + 1$, the following process may be carried out. When the total_len reaches a value meeting formula (2), the number of “1”s (assumed to be n1) of (sync_0_len - ($2 \times n + 1$)) bits from the input bit at that time in the output bits is counted. When the number of “1”s is less than ($2 \times n + 1$), i.e., when $n1 < (2 \times n + 1)$, ($2 \times n + 1 - n1$) bits are removed.

In the output coding unit and the input decoding unit, if the aforementioned processes are carried out so that the synchronization code inserting interval sync_period has a smaller number of bits than the length of the synchronization code, the number of bits of the stuffing bits STUFF can be decreased, so that the coding efficiency can be improved. In particular, when a synchronization code is long, or when many synchronization codes are inserted, the degree of the enhanced coding efficiency due to the decrease of the number of bits of the stuffing bits STUFF is great. For example, in a system for dividing a screen into one or a plurality of macro blocks or macro block lines to insert synchronization codes into each unit, such as a GOB/slice in a dynamic image coding, many dynamic image patterns are inserted, so that the degree of the coding efficiency due to the decrease of the number of bits of the STUFF is increased.

In addition, when a structure having a plurality of layers is multiplexed as shown in FIG. 28, synchronization codes having different lengths in accordance with layers may be used.

FIG. 34(a) shows examples of such synchronization codes. Among four kinds of synchronization codes, each of SSC, SEC and PSC has 32 bits, which comprises “0”s of 23 bits, a “1” of 1 bit and 8 bits representative of the kind of the synchronization code. On the other hand, a synchronization code GSC of a GOB layer is a synchronization code of 17 bits, which comprises “0”s of 16 bits and a “1” of 1 bit, and is a shorter code word than other synchronization codes.

The reason why only the GSC is such a shorter code word is as follows. The GOB is a coded unit, which comprises one or a plurality of macro blocks (MB) and which is formed by dividing a screen into small regions, so that there are generally more synchronization codes of the GOB layer than other synchronization codes. Therefore, if the synchronization code length is decreased, the code amount of the output code string can be decreased. In addition, it is possible to output more GSCs if the code amount is the same, and it is possible to divide the screen into small GOB regions for encoding, so that the quality of a reproduced image can be improved when a transmission line error occurs.

A process for preventing a pseudo synchronization as described in the fourth preferred embodiment, i.e., a bit stuffing process for preventing the same bit pattern as a synchronization code from being produced in a code string other than the synchronization code, may be carried out. If a bit stuffing process for decreasing the probability of error detection of a synchronization code due to a transmission line error, e.g., a bit stuffing process for preventing the same bit pattern as a shortest synchronization code (GSC in the example of FIG. 34(a)) from being produced in a bit string, for which it is ensured only that the same bit pattern as a long bit length of synchronization code (SSC, SEC, PSC in the example of FIG. 34(a)) is not produced, is carried out, it is possible to prevent the same bit patterns as all the synchronization codes from being produced. This process may be carried out for the code strings of all the layers, or for code strings of lower layers (GOB layer, macro block layer in the shown example) than a layer using the shortest code, or for code strings of layers (picture layer, GOB layer, macro block layer) below a layer immediately above that layer. Alternatively, this process may be carried out only for code strings of a predetermined layer.

In order to easily identify synchronization codes of different lengths even if a transmission line error occurs, the process of a synchronization code or before and after the synchronization code may be carried out as follows.

(i) In a case where a synchronization code comprising a plurality of bits of “0”s and the subsequent “1” is used, the relative positions of a long code word and a short code word from the synchronization code inserting position of the “1” may be different. In the example of FIG. 34(b), the “1” **3211** of the PSC and the “1” **3412** of the GSC are arranged at different position, and all of bits (**3413** to **3411**, **3414** to **3412**) are arranged at the same positions in other synchronization codes are “0”. Thus, since the humming distance of the synchronization code and a partial code string thereof is increased, it is possible to easily identify different synchronization codes even if a transmission line error occurs.

(ii) A stuffing bit may be inserted before a short synchronization code. For example, if a stuffing bit **3401** comprising one or a plurality of “1”s is inserted before a short GSC, the humming distance between the OSC and a partial code string of another synchronization code can be increased.

(iii) A stuffing bit may be inserted after a short synchronization code. For example, a bit insertion **3402** may be carried out after a GSC so as to increase the humming distance from a portion identifying the kind of a synchronization code in long synchronization codes.

FIFTH PREFERRED EMBODIMENT

The fifth preferred embodiment of the present invention will be described below.

In this preferred embodiment, the whole constructions of a dynamic image coding system and a dynamic image decoding system are the same as those in the first preferred embodi-

ment, except for the processes carried out at the head and end portions of a synchronization interval by an output coding unit **200** and an input decoding unit **800**.

FIGS. **27(a)**, **27(b)** and **27(c)** are examples of an output code string **205** of a dynamic image coding system in this preferred embodiment. In this output code string **205**, a part **2701** of a code string of the last frame (frame $n-1$) is arranged after a synchronization code PSC, and a pointer information **2702** (SA) representative of a boundary **2703** (a start point of a code string of the current frame) between the code string **2701** and the current frame (n frame), i.e., the boundary between multiplexed code strings, is arranged, so that the stuffing bit (STUFF in FIG. **4**) does not exist at the last of one frame. At this point, this output code string **205** is different from the output code string of FIG. **4**.

In the output coding unit **200** of the dynamic image coding system, the number of bits `resid_bit` of the residual code strings of the frame is checked at each synchronization code inserting position. When the sum of the `resid_bit` and the numbers of bits of a synchronization code, PSC and a pointer information SA is less than synchronization code inserting interval `sync_period` bits, the synchronization code PSC is outputted before the residual code strings of the frame are outputted to the output code string **205**. Then, the pointer information SA (representative of the `resid_bit` in this case) is outputted, and then, the residual code strings **2701** are outputted. Thereafter, the code strings of the next frame are outputted.

In the input coding system **800** of the dynamic image decoding system, a synchronization code is detected at each of synchronization code inserting positions. When the synchronization code is detected, it is determined that the pointer information SA and the residual information of the frame are arranged after the detected synchronization code, and the subsequent process is carried out.

For example, the boundary between a frame $n-1$ and a frame n in FIG. **27** will be described. After the decoding process immediately before **2704** the synchronization code PSC is completed, a synchronization code is detected in the subsequent synchronization code inserting interval. When the synchronization code is detected, the pointer information **2702** is decoded, and it is derived which bits the code strings of the frame $n-1$ have. On the basis of this, the bits of the number of bits indicated by the pointer information are taken out of the code string immediately after the pointer information (to **2703** in FIG. **27**), and the code string **801** is outputted so that these are arranged after **2704**.

In this preferred embodiment, the error correction-/detection coding of a part or all of the output code strings may be carried out as shown in FIG. **27(a)**. In this case, all the kinds of the error correcting/detecting codes may be the same or different.

In addition, as shown in FIG. **27(b)**, the error correction/detection coding may not be carried out.

Moreover, as shown in FIG. **27(c)**, the frame length information POINTER representative of the number of bits of code strings of one frame as shown in FIGS. **15** and **16** may be inserted. In this case, the frame length information POINTER may be representative of the number of bits from the synchronization code PSC of the frame to a synchronization code PSC of the next frame.

In a case where the error correction/detection coding is carried out as shown in FIG. **27(a)**, the pointer information SA, the residual code strings **2701** of the frame $n-1$, and the code-strings of the frame n after **2703** are combined to be one information bit, and the error correction/detection coding of the combined information bit is carried out.

The pointer information SA may be information, for which the error correction/detection coding has been carried out. In this case, the synchronization code PSC (or a part thereof), the frame length information POINTER and the pointer information may be combined to carry out the error correction/detection coding.

Examples of stuffing bits STUFF will be described below.

FIGS. **30(a)** and **30(b)** shows examples of code tables of stuffing bits STUFF as examples of the aforementioned stuffing bits STUFF. Both of FIGS. **30(a)** and **30(b)** are characterized in that the decoding can be uniformly carried out in the backward direction to an output code string, so that the starting position of the stuffing bits STUFF can be uniformly identified. Therefore, an error mixed into a code string can be detected by comparing the decoding end position of a code string immediately before the stuffing bit STUFF with the starting position of the stuffing bit STUFF, and the starting point of the backward decoding can be identified when a coding system for decoding in a backward direction from a synchronization code is used.

Moreover, in the stuffing bits STUFF shown in the code tables of FIGS. **30(a)** and **30(b)**, the first bit is always "0", so that the error detection can be carried out by a simplified decoding as described later.

FIG. **31** shows an example of a decoding process of a code string, which contains the stuffing bits STUFF shown in the code tables of FIGS. **30(a)** and **30(b)**. Although FIG. **31** shows an example of the stuffing bit immediately before the synchronization code inserting position, the same process can be carried out by inserting a stuffing bit immediately before another optional synchronization code inserting position. In FIG. **31**, arrows **3101** through **3103** denote examples of decoding end positions of a code string (indicated by "xxx . . .") immediately before the stuffing bit STUFF when the decoding is carried out in a forward direction, and the right end of each of the arrows indicates the decoding end position. When no error is mixed into a code string and the decoding is normally carried out, the decoding end position of a code string immediately before the stuffing bit STUFF is coincident with the starting position of the stuffing bit STUFF as shown by the arrow **3101**.

On the other hand, when an error is mixed into a code string, the decoding end position of a code string immediately before the stuffing bit STUFF is shifted from the starting position of the stuffing bit STUFF as shown by the arrows **3102** and **3103**. In such a case, it is determined that an error exists in the code string.

In the decoding system, when the decoding of a code string immediately before the stuffing bit STUFF is completed, the stuffing bit STUFF before the next synchronization code inserting position is read, and it is determined whether the read stuffing bit STUFF is coincident with the codes in the code table shown in FIGS. **30(a)** and **30(b)**. If the stuffing bit STUFF is not coincident with any codes, it is determined that an error exist.

When it is determined whether the stuffing bit STUFF is coincident with the code table, a small bit error may be allowable. Thus, it is possible to decrease the error detection of an error when an error is mixed into the stuffing bit STUFF itself.

The code table of FIG. **30(a)** always starts from "0" and has the subsequent bits of "1"s. Therefore, in order to carry out the error detection, it may be determined only whether the next bit to the decoding end position of the code string immediately before the stuffing bit STUFF is "0", or the error detection may be carried out only by the first "0" and the subsequent some "1"s. Thus, although the error detection-

accuracy is slightly lowered, the throughput required to decoding can be decreased. Thus, in a case where a code table starting from a specific bit pattern, in which all the stuffing bits STUFF comprise a specific bit or a plurality of bits, is used, the decoding process can be simplified.

Moreover, the stuffing bits STUFF shown in the code tables of FIG. 30(a) and 30(b) contain a lot of bits of "1", and the humming distances from the synchronization code containing a lot of "0"s and a part thereof are great as shown in FIG. 5, so that there is an advantage in that the probability that a pseudo synchronization occurs is low. Specifically, in the code table of FIG. 30(a), all of only the first bits of the stuffing bits STUFF are "0", and all of the other bits are "0", so that the humming distance between the synchronization codes, all of which are "0", and a part thereof is (the length of the stuffing bit STUFF is -1). In addition, in the code table of FIG. 30(b), only the first and last bits of the stuffing bits STUFF are "0", and all the other bits are "1", so that the humming distances from the synchronization code and a part thereof are (the length of the stuffing bit STUFF is -2). Thus, if the humming distances between the stuffing bit STUFF, and the synchronization code and a part thereof are selected so as to be greater than a predetermined value, e.g., (the length of the stuffing bit STUFF -2), so that it is difficult to produce a pseudo synchronization code even if an error is mixed into a code string.

Referring to FIG. 32, this effect will be described. FIGS. 32(a-0) and 32(b-0) show examples of code strings when usual stuffing bits (all the bits are "0") and time stuffing bits STUFF shown in the code table of FIG. 30(a) are used, and FIGS. 32(a-1) and 32(b-1) show examples when an error of 1 bit is mixed in FIGS. 32(a-0) and 32(b-0), respectively. As can be seen from FIG. 32(a-1), if only an error of 1 bit is mixed into the usual stuffing bits wherein all the bits are "0", the same bit pattern as the synchronization code is produced as shown by the broken line in FIG. 32(a-1), so that a pseudo synchronization occurs. On the other hand, the stuffing bit STUFF representative of the code table of FIG. 30(b) is not the same pattern as the synchronization code even if an error is mixed as shown in FIG. 32(b-2), so that no pseudo synchronization occurs.

Thus, the stuffing bit in this preferred embodiment has advantages in that it is possible to easily detect an error of a code string, and it is difficult to produce a pseudo synchronization code even if an error is mixed into a code string, so that it is possible to provide a strong error resistance.

In addition, the stuffing bit in this preferred embodiment can uniformly decode in the backward direction, and identify the starting position thereof, i.e., the end position of a code string immediately before the stuffing bit STUFF. Therefore, after the coding, by which an information code string can be decoded in both of forward and backward directions, is carried out, the code string immediately before the STUFF can be decoded in the backward direction as shown by the arrow 3104 in FIG. 31.

In the aforementioned preferred embodiment, the stuffing bit STUFF may be determined as follows.

(1) In a case where a synchronization code contains "0"s of sync_0_len bits as shown in FIG. 5, if all the bits of the stuffing bits STUFF or at least at the synchronization code inserting positions are set to be "1", the humming distances between the portions of "0" of the synchronization code and the stuffing bits STUFF can be increased. Therefore, it is possible to decrease the probability that an error is mixed into the stuffing bits STUFF to produce a pseudo synchronization.

(2) The stuffing bit STUFF may be a code word representative of the length thereof. In the decoding system, the length of the STUFF from the point, at which the decoding of a code

string other than the stuffing bit STUFF is completed, is determined, and the decoding of the STUFF is decoded to decode the length information of the STUFF. In this case, if both are coincident with each other, it can be determined that an error is mixed into the code string.

In addition, the length of the code string of the stuffing bits STUFF may be indicated by binary numbers. For example, if the STUFFs are 5 bits, "5" may be indicated by binary numbers so as to be "00101". Alternatively, a value derived by taking a complement of "1" or "2" from a value indicated by binary numbers may be used as a code word of the stuffing bits STUFF. Thus, the number of bits of "0"s in the STUFFs is decreased, so that it is possible to inhibit a pseudo synchronization from occurring similar to the aforementioned (1).

(3) In a case where the coding is carried out using a code word which can be decoded in both of forward and backward directions, it is required to decode the stuffing bits STUFFs in the backward direction from the end point of the frame in the decoding system, to find the starting point (the boundary point between the STUFF and another code word). In such a case, the STUFFs may be determined so as to be a code word, which starts from "0"(s) of 1 bit or a plurality of bits and has the residuals of "1"s, such as "01111111". Thus, if the STUFFs are decoded in the backward direction to seek the position of "0", it can be uniformly determined that the sought position is the starting point of the STUFFs. In addition, in this example, the bits other than the initial portion of the stuffing bits STUFFs are "1", so that it is possible to decrease the probability that a pseudo synchronization occurs similar to the aforementioned (1).

(4) The stuffing bit STUFF may be a check bit, a parity check bit or the like for an error correcting/detecting code of a part or all of bits of an output code string. Thus, the error correction/detection of a bit error mixed into an output code string can be carried out.

As described in the above examples, stuffing bits STUFFs are produced in accordance with a predetermined rule, and the stuffing bits STUFFs in an input code string are checked with the producing rule in a decoding system. If it is determined that the stuffing bits STUFFs are against the producing rule, it can be determined that an error is mixed into the input code string. Thus, if a process for preventing a reproduced image from being greatly deteriorated is carried out in a dynamic image decoding system, it is possible to improve the quality of a reproduced image when an error is mixed into the input code string.

Moreover, in the aforementioned preferred embodiment, the synchronization code inserting interval sync_period may be determined as follows.

(1) In a case where an error correcting/detecting code is used, a synchronization code inserting interval sync_period may be greater than the minimum number of bits required to carry out the synchronization detection by means of a decoding system, i.e., the sum of the length of a synchronization code and the maximum value of a check bit for an error correcting/detecting code. Since the mean value of the numbers of bits of the last stuffing bits STUFFs of a frame is $\text{sync_period}/2$, if the sync_period has the minimum bits, by which the synchronization detection can be carried out, it is possible to decrease the number of bits of the stuffing bits STUFFs to improve the coding efficiency.

(2) In a case where no error correcting/detecting code is used, a synchronization code inserting interval sync_period may be greater than the minimum number of bits required to carry out the synchronization detection by means of a decoding system, i.e., the length of a synchronization code. Since the mean value of the numbers of bits of the last stuffing bits

39

STUFFs of a frame is $\text{sync_period}/2$, if the sync_period has the minimum bits, by which the synchronization detection can be carried out, it is possible to decrease the number of bits of the stuffing bits STUFFs to improve the coding efficiency.

(3) In a case where a frame length information POINTER is used as shown in FIGS. 15, 16, 17 and 27, a synchronization code inserting interval sync_period may be shorter than the length of a synchronization code. Thus, it is possible to decrease the number of bits of the stuffing bits STUFFs to improve the coding efficiency.

(4) In a case where the transmission/storage is carried out by dividing into packets or cells at intervals determined in a transmission line or a storage medium, a synchronization code inserting interval sync_period may be matched with the interval of the packets or cells, or a divisor thereof. Thus, since the head of the packets or cells is always arranged at the synchronization code inserting position, it is possible to detect a synchronization code even if a packet or cell is produced due to packet loss or cell loss.

(5) The synchronization code inserting interval sync_period is preferably shorter than the required minimum number of bits of a frame. Thus, it is possible to decrease the number of bits of the stuffing bits STUFFs to improve the coding efficiency.

SIXTH PREFERRED EMBODIMENT

The sixth preferred embodiment of the present invention will be described.

FIG. 35 shows examples of output code strings of a dynamic image coding system in this preferred embodiment. In these output code strings, in order to decrease the probability of the error detection of a synchronization code due to errors, the bit inserting process as described in the aforementioned preferred embodiments is carried out. In addition, information, such as header information, is arranged at predetermined positions, or at predetermined positions based on a synchronization code.

FIG. 35(a) is a code string before a bit inserting process is carried out, and FIG. 35(b) is a code string after a bit inserting process is carried out. In the drawings, each of the portions 3201, 3202, 3261 and 3262 shown by the slanting lines shows information arranged at the predetermined position (the predetermined position based on a synchronization code), and each of void arrows 3211 and 3212 indicates the position, into which the information is inserted. The information 3261 and information 3262 of the code string in FIG. 35(b) corresponds to the information 3201 and information 3202 of the code string in FIG. 35(a), respectively. In some cases, when the code string (a) is transformed to the code string (b), these information may be transformed (i.e., the transformation from information 3201 to information 3261 and the transformation from information 3202 to information 3262).

In FIG. 35(b), 3203 denotes a bit inserted by the bit inserting process. Since the bit string subsequently to the inserted bit is shifted backward by the bit inserting process, a part of a code string immediately before the information to be inserted at a predetermined position is shifted so that the information is inserted at the predetermined position. For example, assuming that the total of the numbers of inserted bits from the synchronization code 3205 immediately before the information 3201 is $Ns1$, $Ns1$ bits indicated by sign 3221 in FIG. 35(a) immediately before the information 3201 may be shifted to the portion of sign 3231 in FIG. 35(b) immediately after the information 3201.

If information such as a pointer representative of a specific position in a code string is contained in information 3201

40

and/or 3202, this may be transformed. Specifically, for example, if information representative of the position indicated by arrow 3241 is contained in information 3201, the information representative of the position in information 3261 is transformed so as to indicate the position representative of arrow 3251 after the position by the number $Ns1$ of the inserted bits.

The invention claimed is:

1. A decoding method, comprising:

decoding an input code string, the input code string having a synchronization code inserted at one of a plurality of predetermined periodic synchronization code inserting positions and having a stuffing code capable of being uniquely decoded in a backward direction; and

comparing a decoding end position of a code string positioned immediately before the stuffing code with a start position of the stuffing code to detect an error in the input code string, the decoding end position of a code string being identified by decoding the code string in a forward direction, and the start position of the stuffing code being identified by decoding the stuffing code in the backward direction.

2. A decoding method, comprising:

detecting a synchronization code at a plurality of predetermined periodic synchronization code inserting positions in an input code string, the input code string having a multiplexed code string obtained by multiplexing a plurality of variable length code strings and having a stuffing code capable of being uniquely decoded in a backward direction, each of the plurality of variable length code strings being generated by compressing and coding an image signal;

demultiplexing the multiplexed code string in the input code string based on a position of the detected synchronization code to generate the variable length code; decoding the generated variable length code to output a reproduced image signal; and

detecting an error in the input code string by decoding the input code string and comparing a decoding end position of a code string positioned immediately before the stuffing code with a start position of the stuffing code, the decoding end position of a code string being identified by decoding the code string in a forward direction, and the start position of the stuffing code being identified by decoding the stuffing code in the backward direction.

3. A decoder, comprising:

a decoding unit configured to decode an input code string, the input code string having a synchronization code inserted at one of a plurality of predetermined periodic synchronization code inserting positions and having a stuffing code capable of being uniquely decoded in a backward direction; and

an error detector configured to detect an error in the input code string by comparing a decoding end position of a code string positioned immediately before the stuffing code with a start position of the stuffing code, the decoding end position of a code string being identified by decoding the code string in a forward direction, and the start position of the stuffing code being identified by decoding the stuffing code in the backward direction.

4. The decoder according to claim 3,

wherein the stuffing code is inserted immediately before one of the plurality of synchronization code inserting positions.

41

5. The decoder according to claim 3,
 wherein the stuffing code has a Hamming distance between
 the synchronization code and a portion of the synchroni-
 zation code, the Hamming distance being a predeter-
 mined value or more. 5

6. A decoder, comprising:
 a synchronization code decoding unit configured to detect
 a synchronization code at a plurality of predetermined
 periodic synchronization code inserting positions in an
 input code string, the input code string having a multi- 10
 plexed code string obtained by multiplexing a plurality
 of variable length code strings and having a stuffing code
 capable of being uniquely decoded in a backward direc-
 tion, each of the plurality of variable length code strings 15
 being generated by compressing and coding an image
 signal;
 a demultiplexer configured to demultiplex the multiplexed
 code string in the input code string based on a position of
 the detected synchronization code to generate the vari-
 able length code; 20
 a variable length decoding unit configured to decode the
 generated variable length code to output a reproduced
 image signal;
 an input code string decoding unit configured to decode the
 input code string; and 25
 an error detector configured to detect an error in the input
 code string by comparing a decoding end position of a
 code string positioned immediately before the stuffing
 code with a start position of the stuffing code, the decod-
 ing end position of a code string being identified by 30
 decoding the code string in a forward direction, and the
 start position of the stuffing code being identified by
 decoding the stuffing code in the backward direction.

7. The decoder according to claim 6,
 wherein the multiplexed code string is generated by mul- 35
 tiplexing the variable length codes in units that are each
 a frame of the image signal; and
 the demultiplexer demultiplexes the multiplexed code
 string in units that are each a frame.

42

8. The decoder according to claim 6,
 wherein the multiplexed code string is generated by mul-
 tiplexing the variable length codes in units that are each
 a partial area in a frame of the image signal; and
 the demultiplexer demultiplexes the multiplexed code
 string in units that are each a partial area in the frame.

9. The decoder according to claim 6,
 wherein the multiplexed code string is generated by mul-
 tiplexing the variable length codes in units that are each
 a frame of the image signal;
 the synchronization code detector detects the synchroniza-
 tion code at the synchronization code inserting position
 positioned immediately before or after an end portion in
 each multiplexed unit multiplexed in units that are each
 a frame of the multiplexed code string; and
 the demultiplexer demultiplexes the multiplexed code
 string in units that are each a frame.

10. The decoder according to claim 6,
 wherein the multiplexed code string is generated by mul-
 tiplexing the variable length codes in units that are each
 a partial area in a frame of the image signal;
 the synchronization code detector detects the synchroniza-
 tion code at the synchronization code inserting position
 positioned immediately before or after an end portion in
 each multiplexed unit multiplexed in units that are each
 a partial area in the frame of the multiplexed code string;
 and
 the demultiplexer demultiplexes the multiplexed code
 string in units that are each a partial area in the frame.

11. The decoder according to claim 6, further comprising:
 a code string converter configured to deconvert a code
 string, when it is not the synchronization code and is
 positioned in the synchronization code inserting posi-
 tion in the output string and is converted to set a Ham-
 ming distance from the synchronization code to be a
 predetermined value or more, into an original code
 string.

* * * * *