



US007420201B2

(12) **United States Patent**
Langdo et al.

(10) **Patent No.:** **US 7,420,201 B2**
(45) **Date of Patent:** **Sep. 2, 2008**

(54) **STRAINED-SEMICONDUCTOR-ON-INSULATOR DEVICE STRUCTURES WITH ELEVATED SOURCE/DRAIN REGIONS**

(58) **Field of Classification Search** 257/E29.295, 257/E29.297, E29.298, E29.2, 18, 190, 192
See application file for complete search history.

(75) Inventors: **Thomas A. Langdo**, Cambridge, MA (US); **Matthew T. Currie**, Brookline, MA (US); **Richard Hammond**, HARRISEAHEAD (GB); **Anthony J. Lochtefeld**, Somerville, MA (US); **Eugene A. Fitzgerald**, Windham, NH (US)

(56) **References Cited**

U.S. PATENT DOCUMENTS

4,010,045	A	3/1977	Ruehrwein	
4,282,543	A *	8/1981	Ihara et al.	428/428
4,329,706	A *	5/1982	Crowder et al.	257/313
4,370,510	A	1/1983	Stirn	
4,522,662	A	6/1985	Bradbury et al.	

(Continued)

FOREIGN PATENT DOCUMENTS

DE	41 01 167	7/1992
EP	0390661	10/1990
EP	0 514 018	11/1992
EP	0 587 520	3/1994
EP	0 683 522	11/1995

(Continued)

OTHER PUBLICATIONS

"2 Bit/Cell EEPROM Cell Using Band to Band Tunneling for Data Read-Out," IBM Technical Disclosure Bulletin, vol. 35, No. 4B (Sep. 1992) pp. 136-140.

(Continued)

Primary Examiner—Thomas L Dickey
(74) *Attorney, Agent, or Firm*—Goodwin Procter LLP

(57) **ABSTRACT**

The benefits of strained semiconductors are combined with silicon-on-insulator approaches to substrate and device fabrication.

(73) Assignee: **AmberWave Systems Corporation**, Salem, NH (US)

(*) Notice: Subject to any disclaimer, the term of this patent is extended or adjusted under 35 U.S.C. 154(b) by 0 days.

(21) Appl. No.: **11/125,507**

(22) Filed: **May 10, 2005**

(65) **Prior Publication Data**

US 2005/0218453 A1 Oct. 6, 2005

Related U.S. Application Data

(63) Continuation of application No. 10/456,103, filed on Jun. 6, 2003, now Pat. No. 6,995,430.

(60) Provisional application No. 60/416,000, filed on Oct. 4, 2002, provisional application No. 60/404,058, filed on Aug. 15, 2002, provisional application No. 60/386,968, filed on Jun. 7, 2002.

(51) **Int. Cl.**
H01L 21/336 (2006.01)

(52) **U.S. Cl.** **257/18; 257/192; 257/E29.295**

25 Claims, 23 Drawing Sheets

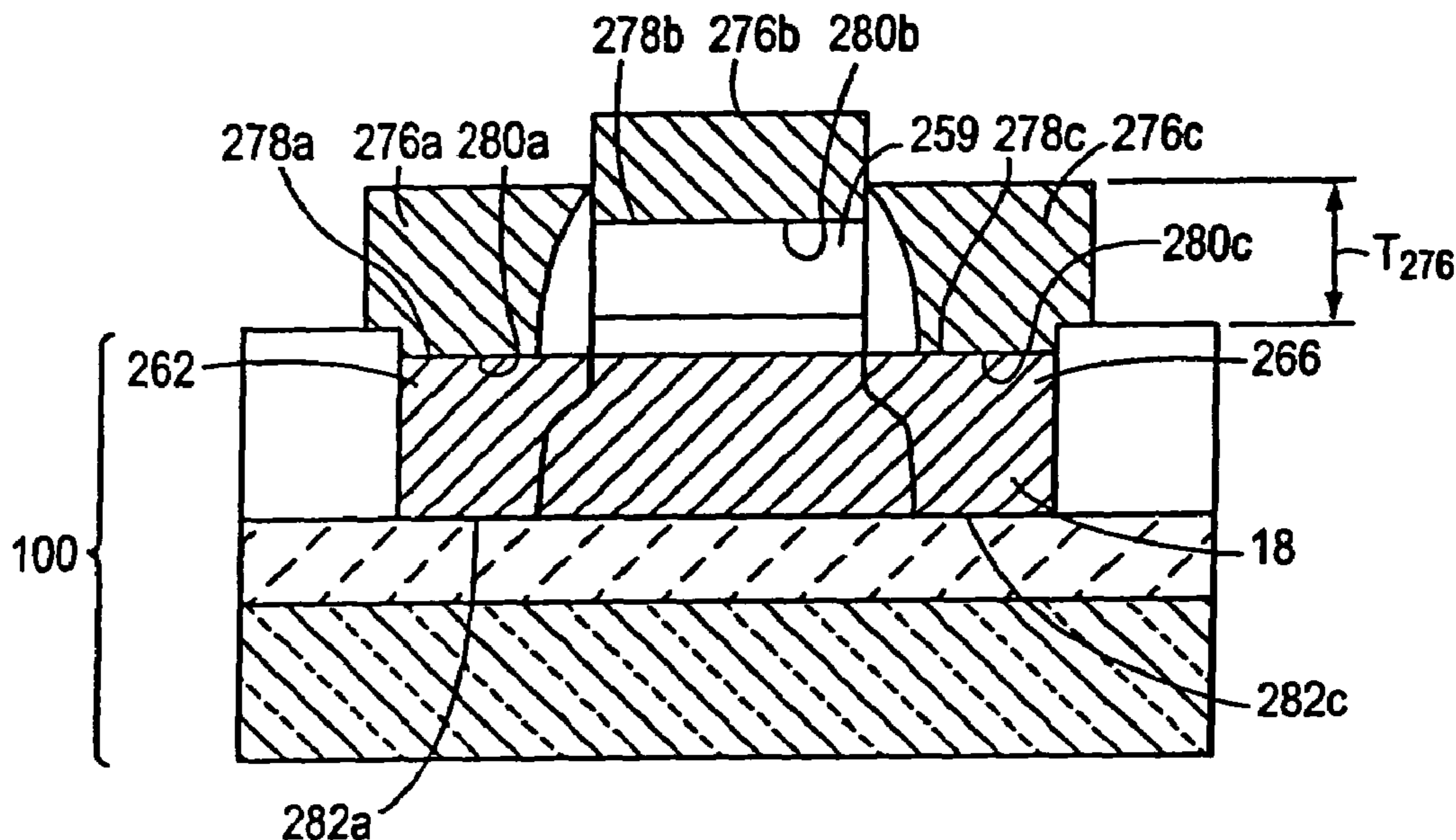

US 7,420,201 B2

U.S. PATENT DOCUMENTS				
		5,698,869	A	12/1997 Yoshimi et al.
		5,705,421	A	1/1998 Matsushita et al.
4,570,328	A * 2/1986 Price et al. 438/586	5,710,450	A	1/1998 Chau et al.
4,649,859	A 3/1987 Wanlass	5,714,413	A	2/1998 Brigham et al.
4,704,302	A 11/1987 Bruel et al.	5,714,777	A	2/1998 Ismail et al.
4,710,788	A 12/1987 Dämbkes et al.	5,728,623	A	3/1998 Mori
4,749,441	A 6/1988 Christenson et al.	5,739,567	A	4/1998 Wong
4,786,615	A 11/1988 Liaw et al.	5,759,898	A	6/1998 Ek et al.
4,833,513	A * 5/1989 Sasaki 257/342	5,777,347	A	7/1998 Bartelink
4,851,078	A 7/1989 Short et al.	5,786,612	A	7/1998 Otani et al.
4,857,986	A 8/1989 Kinugawa et al.	5,786,614	A	7/1998 Chuang et al.
4,963,506	A 10/1990 Liaw et al.	5,792,679	A	8/1998 Nakato
4,987,462	A 1/1991 Kim et al.	5,808,344	A	9/1998 Ismail et al.
4,990,979	A 2/1991 Otto	5,821,577	A	10/1998 Crabbé et al.
4,997,776	A 3/1991 Harame et al.	5,847,419	A	12/1998 Imai et al.
5,013,681	A 5/1991 Godbey et al.	5,855,693	A	1/1999 Murari et al.
5,034,348	A 7/1991 Hartswick et al.	5,863,830	A	1/1999 Bruel et al.
5,089,872	A 2/1992 Ozturk et al.	5,876,796	A	3/1999 Regolini et al.
5,091,767	A 2/1992 Bean et al.	5,877,070	A	3/1999 Goesele et al.
5,108,946	A 4/1992 Zdebel et al.	5,882,987	A	3/1999 Srikrishnan
5,155,571	A 10/1992 Wang et al.	5,891,769	A	4/1999 Hong et al.
5,166,084	A 11/1992 Pfiester	5,906,708	A	5/1999 Robinson et al.
5,177,583	A 1/1993 Endo et al.	5,912,479	A	6/1999 Mori et al.
5,202,284	A 4/1993 Kamins et al.	5,923,046	A	7/1999 Tezuka et al.
5,207,864	A 5/1993 Bhat et al.	5,930,632	A	7/1999 Gardner et al.
5,208,182	A 5/1993 Narayan et al.	5,943,560	A	8/1999 Chang et al.
5,212,110	A 5/1993 Pfiester et al.	5,951,757	A *	9/1999 Dubbelday et al. 117/102
5,212,112	A 5/1993 Lynch	5,963,817	A	10/1999 Chu et al.
5,221,413	A 6/1993 Brasen et al.	5,966,622	A	10/1999 Levine et al.
5,225,703	A 7/1993 Nakatani	5,976,939	A	11/1999 Thompson et al.
5,240,876	A 8/1993 Gaul et al.	5,993,677	A	11/1999 Biasse et al.
5,241,197	A 8/1993 Murakami et al.	5,998,807	A *	12/1999 Lustig et al. 257/66
5,242,847	A 9/1993 Ozturk et al.	6,013,134	A	1/2000 Chu et al.
5,243,207	A 9/1993 Plumton et al.	6,013,553	A	1/2000 Wallace et al.
5,250,445	A 10/1993 Bean et al.	6,013,563	A	1/2000 Henley et al.
5,285,086	A 2/1994 Fitzgerald	6,020,252	A	2/2000 Aspar et al.
5,291,439	A 3/1994 Kauffmann et al.	6,030,887	A	2/2000 Desai et al.
5,294,564	A 3/1994 Karapiperis et al.	6,030,889	A	2/2000 Aulicino et al.
5,298,452	A 3/1994 Meyerson	6,033,974	A	3/2000 Henley et al.
5,304,834	A 4/1994 Lynch	6,033,995	A	3/2000 Muller
5,310,451	A 5/1994 Tejwani et al.	6,058,044	A	5/2000 Sugiura et al.
5,316,958	A 5/1994 Meyerson	6,059,895	A	5/2000 Chu et al.
5,346,848	A 9/1994 Grupen-Shemansky et al.	6,074,919	A	6/2000 Gardner et al.
5,374,564	A 12/1994 Bruel	6,096,590	A	8/2000 Chan et al.
5,399,522	A 3/1995 Ogori	6,103,559	A	8/2000 Gardner et al.
5,405,802	A 4/1995 Yamagata et al.	6,103,597	A	8/2000 Aspar et al.
5,413,679	A 5/1995 Godbey	6,103,599	A	8/2000 Henley et al.
5,424,243	A 6/1995 Takasaki	6,107,653	A	8/2000 Fitzgerald
5,426,069	A 6/1995 Selvakumar et al.	6,111,267	A	8/2000 Fischer et al.
5,426,316	A 6/1995 Mohammad	6,117,750	A	9/2000 Bensahel et al.
5,439,843	A 8/1995 Sakaguchi et al.	6,130,453	A	10/2000 Mei et al.
5,442,205	A 8/1995 Brasen et al.	6,133,799	A	10/2000 Favors, Jr. et al.
5,461,243	A 10/1995 Ek et al.	6,140,687	A	10/2000 Shimomura et al.
5,461,250	A 10/1995 Burghartz et al.	6,143,636	A	11/2000 Forbes et al.
5,462,883	A 10/1995 Dennard et al.	6,153,495	A	11/2000 Kub et al.
5,476,813	A 12/1995 Naruse	6,154,475	A	11/2000 Soref et al.
5,479,033	A 12/1995 Baca et al.	6,159,852	A	12/2000 Nuttall et al.
5,484,664	A 1/1996 Kitahara et al.	6,160,303	A	12/2000 Fattaruso
5,523,243	A 6/1996 Mohammad	6,162,688	A	12/2000 Gardner et al.
5,523,592	A 6/1996 Nakagawa et al.	6,162,705	A	12/2000 Henley et al.
5,534,713	A 7/1996 Ismail et al.	6,166,411	A	12/2000 Buynoski
5,536,361	A 7/1996 Kondo et al.	6,184,111	B1	2/2001 Henley et al.
5,540,785	A 7/1996 Dennard et al.	6,190,998	B1	2/2001 Bruel et al.
5,548,128	A 8/1996 Soref et al.	6,191,007	B1	2/2001 Matsui et al.
5,571,373	A 11/1996 Krishna et al.	6,191,432	B1	2/2001 Sugiyama et al.
5,572,043	A 11/1996 Shimizu et al.	6,194,722	B1	2/2001 Howe et al.
5,596,527	A 1/1997 Tomioka et al.	6,204,529	B1	3/2001 Lung et al.
5,607,876	A 3/1997 Biegelsen et al.	6,207,977	B1	3/2001 Augusto
5,617,351	A 4/1997 Bertin et al.	6,210,988	B1	4/2001 Howe et al.
5,630,905	A 5/1997 Lynch et al.	6,218,677	B1	4/2001 Broekaert
5,633,202	A 5/1997 Brigham et al.	6,225,192	B1	5/2001 Aspar et al.
5,659,187	A 8/1997 Legoues et al.	6,228,694	B1	5/2001 Doyle et al.
5,683,934	A 11/1997 Candelaria	6,232,138	B1	5/2001 Fitzgerald et al.

US 7,420,201 B2

6,235,567 B1	5/2001	Huang	6,583,015 B2	6/2003	Fitzgerald et al.
6,235,568 B1	5/2001	Murthy et al.	6,583,437 B2	6/2003	Mizuno et al.
6,242,324 B1	6/2001	Kub et al.	6,591,321 B1	7/2003	Arimilli et al.
6,242,327 B1	6/2001	Yokoyama et al.	6,593,191 B2	7/2003	Fitzgerald
6,249,022 B1	6/2001	Lin et al.	6,593,625 B2	7/2003	Christiansen et al.
6,251,751 B1	6/2001	Chu et al.	6,593,641 B1	7/2003	Fitzgerald
6,251,755 B1	6/2001	Furukawa et al.	6,596,610 B1	7/2003	Kuwabara et al.
6,251,780 B1	6/2001	Sohn et al.	6,597,016 B1	7/2003	Yuki et al.
6,261,929 B1	7/2001	Gehrke et al.	6,602,613 B1	8/2003	Fitzgerald
6,266,278 B1	7/2001	Harari et al.	6,603,156 B2	8/2003	Rim
6,271,551 B1	8/2001	Schmitz et al.	6,605,498 B1	8/2003	Murthy et al.
6,271,726 B1	8/2001	Fransis et al.	6,607,948 B1	8/2003	Sugiyama et al.
6,281,532 B1	8/2001	Doyle et al.	6,621,131 B2	9/2003	Murthy et al.
6,290,804 B1	9/2001	Henley et al.	6,624,047 B1	9/2003	Sakaguchi et al.
6,291,321 B1	9/2001	Fitzgerald	6,624,478 B2	9/2003	Anderson et al.
6,303,468 B1	10/2001	Aspar et al.	6,632,724 B2	10/2003	Henley et al.
6,313,016 B1	11/2001	Kibbel et al.	6,635,909 B2	10/2003	Clark et al.
6,316,301 B1	11/2001	Kant	6,645,831 B1	11/2003	Shaheen et al.
6,319,799 B1 *	11/2001	Ouyang et al. 438/528	6,646,322 B2	11/2003	Fitzgerald
6,323,108 B1	11/2001	Kub et al.	6,649,480 B2	11/2003	Fitzgerald et al.
6,326,281 B1	12/2001	Violette et al.	6,649,492 B2	11/2003	Chu et al.
6,326,664 B1	12/2001	Chau et al.	6,656,271 B2	12/2003	Yonchara et al.
6,326,667 B1	12/2001	Sugiyama et al.	6,657,223 B1	12/2003	Wang et al.
6,329,063 B2	12/2001	Lo et al.	6,664,169 B1	12/2003	Iwasaki et al.
6,335,546 B1	1/2002	Tsuda et al.	6,674,150 B2	1/2004	Takagi et al.
6,339,232 B1	1/2002	Takagi	6,677,183 B2	1/2004	Sakaguchi et al.
6,342,421 B1	1/2002	Mitani et al.	6,677,192 B1	1/2004	Fitzgerald
6,344,375 B1	2/2002	Orita et al.	6,680,240 B1	1/2004	Maszara
6,344,417 B1	2/2002	Usenko	6,680,260 B2	1/2004	Akiyama et al.
6,346,459 B1	2/2002	Usenko et al.	6,682,965 B1	1/2004	Noguchi et al.
6,350,311 B1	2/2002	Chin et al.	6,686,617 B2	2/2004	Agnello et al.
6,350,993 B1	2/2002	Chu et al.	6,689,211 B1	2/2004	Wu et al.
6,352,909 B1	3/2002	Usenko	6,690,043 B1	2/2004	Usuda et al.
6,355,493 B1	3/2002	Usenko	6,699,765 B1	3/2004	Shideler et al.
6,368,733 B1	4/2002	Nishinaga	6,703,144 B2	3/2004	Fitzgerald
6,368,927 B1	4/2002	Lee et al.	6,703,271 B2	3/2004	Yeo et al.
6,368,938 B1	4/2002	Usenko	6,703,648 B1	3/2004	Xiang et al.
6,369,438 B1	4/2002	Sugiyama et al.	6,703,688 B1	3/2004	Fitzgerald
6,372,356 B1	4/2002	Thornton et al.	6,706,614 B1	3/2004	An et al.
6,372,593 B1	4/2002	Hattori et al.	6,706,618 B2	3/2004	Takisawa et al.
6,372,609 B1	4/2002	Aga et al.	6,707,106 B1	3/2004	Wristers et al.
6,376,318 B1	4/2002	Lee et al.	6,709,903 B2	3/2004	Christiansen et al.
6,387,829 B1	5/2002	Usenko et al.	6,709,909 B2	3/2004	Mizuno et al.
6,391,740 B1	5/2002	Cheung et al.	6,709,929 B2	3/2004	Zhang et al.
6,391,798 B1	5/2002	DeFelice et al.	6,713,326 B2	3/2004	Cheng et al.
6,399,970 B2	6/2002	Kubo et al.	6,723,661 B2	4/2004	Fitzgerald
6,403,975 B1	6/2002	Brunner et al.	6,724,008 B2	4/2004	Fitzgerald
6,407,406 B1	6/2002	Tezuka	6,724,019 B2	4/2004	Oda et al.
6,410,371 B1	6/2002	Yu et al.	6,730,551 B2	5/2004	Lee et al.
6,425,951 B1	7/2002	Chu et al.	6,737,670 B2	5/2004	Cheng et al.
6,429,061 B1	8/2002	Rim	6,743,651 B2	6/2004	Chu et al.
6,429,098 B1	8/2002	Bensahel et al.	6,743,684 B2	6/2004	Liu
6,444,578 B1	9/2002	Cabral, Jr. et al.	6,750,130 B1	6/2004	Fitzgerald
6,445,016 B1	9/2002	An et al.	6,764,908 B1	7/2004	Kadosh et al.
6,448,152 B1	9/2002	Henley et al.	6,787,864 B2	9/2004	Paton et al.
6,455,397 B1	9/2002	Belford	6,790,747 B2	9/2004	Henley et al.
6,455,894 B1	9/2002	Matsumoto et al.	6,797,571 B2	9/2004	Nagaoka et al.
6,458,672 B1	10/2002	Henley et al.	6,812,086 B2	11/2004	Murthy et al.
6,475,072 B1	11/2002	Canaperi et al.	6,818,537 B2	11/2004	Cheong et al.
6,489,639 B1	12/2002	Hoke et al.	6,818,938 B1	11/2004	Naem et al.
6,492,216 B1	12/2002	Yeo et al.	6,825,086 B2	11/2004	Lee et al.
6,500,694 B1	12/2002	Enquist	6,828,632 B2	12/2004	Bhattacharyya
6,514,836 B2	2/2003	Belford	6,830,976 B2	12/2004	Fitzgerald
6,515,335 B1	2/2003	Christiansen et al.	6,855,649 B2	2/2005	Christiansen et al.
6,521,041 B2	2/2003	Wu et al.	6,855,990 B2	2/2005	Yeo et al.
6,521,508 B1	2/2003	Cheong et al.	6,861,318 B2	3/2005	Murthy et al.
6,524,935 B1	2/2003	Canaperi et al.	6,876,010 B1	4/2005	Fitzgerald
6,534,380 B1	3/2003	Yamauchi et al.	6,876,053 B1	4/2005	Ma et al.
6,534,381 B2	3/2003	Cheung et al.	6,881,360 B2	4/2005	Stange et al.
6,537,370 B1	3/2003	Hernandez et al.	6,881,630 B2	4/2005	Song et al.
6,555,839 B2	4/2003	Fitzgerald	6,881,632 B2	4/2005	Fitzgerald et al.
6,563,152 B2	5/2003	Roberds et al.	6,885,084 B2	4/2005	Murthy et al.
6,573,126 B2	6/2003	Cheng et al.	6,887,762 B1	5/2005	Murthy et al.

US 7,420,201 B2

6,887,773 B2	5/2005	Gunn, III et al.	2004/0005740 A1	1/2004	Lochtefeld et al.
6,900,103 B2	5/2005	Fitzgerald	2004/0007715 A1	1/2004	Webb et al.
6,909,186 B2	6/2005	Chu	2004/0007724 A1	1/2004	Murthy et al.
6,929,992 B1	8/2005	Djomehri et al.	2004/0009649 A1	1/2004	Kub et al.
6,933,518 B2	8/2005	Braithwaite et al.	2004/0012037 A1	1/2004	Venkatesan et al.
6,936,509 B2	8/2005	Coolbaugh et al.	2004/0012075 A1	1/2004	Bedell et al.
6,940,089 B2	9/2005	Cheng et al.	2004/0014276 A1	1/2004	Murthy et al.
6,946,371 B2	9/2005	Langdo et al.	2004/0014304 A1	1/2004	Bhattacharyya
6,953,972 B2	10/2005	Yeo et al.	2004/0018699 A1	1/2004	Boyd et al.
6,974,733 B2	12/2005	Boyanov et al.	2004/0029323 A1*	2/2004	Shimizu et al. 438/142
6,982,433 B2	1/2006	Hoffman et al.	2004/0031979 A1	2/2004	Lochtefeld
6,982,474 B2	1/2006	Currie et al.	2004/0031990 A1	2/2004	Jin et al.
6,992,355 B2	1/2006	Mouli	2004/0041174 A1	3/2004	Okihara
6,995,430 B2	2/2006	Langdo et al.	2004/0041210 A1	3/2004	Mouli
7,033,905 B2	4/2006	Ghyselen et al.	2004/0048091 A1	3/2004	Sato et al.
7,091,095 B2	8/2006	Chu	2004/0048454 A1	3/2004	Sakaguchi
7,091,520 B2	8/2006	Nakajima et al.	2004/0051140 A1	3/2004	Bhattacharyya
7,227,176 B2	6/2007	Wu et al.	2004/0053477 A1	3/2004	Ghyselen et al.
2001/0001724 A1	5/2001	Kwork et al.	2004/0061191 A1	4/2004	Paton et al.
2001/0003269 A1	6/2001	Wu et al.	2004/0070035 A1	4/2004	Murthy et al.
2001/0003364 A1	6/2001	Sugawara et al.	2004/0075148 A1	4/2004	Kumagai et al.
2001/0007789 A1	7/2001	Aspar et al.	2004/0075149 A1	4/2004	Fitzgerald et al.
2002/0043660 A1	4/2002	Yamazaki et al.	2004/0084735 A1	5/2004	Murthy et al.
2002/0052084 A1	5/2002	Fitzgerald	2004/0110378 A1	6/2004	Ghyselen et al.
2002/0063292 A1	5/2002	Armstrong et al.	2004/0119101 A1	6/2004	Schrom et al.
2002/0072130 A1	6/2002	Cheng et al.	2004/0121564 A1	6/2004	Gogoi
2002/0084000 A1	7/2002	Fitzgerald	2004/0142545 A1	7/2004	Ngo et al.
2002/0096717 A1	7/2002	Chu et al.	2004/0173790 A1	9/2004	Yeo et al.
2002/0100942 A1	8/2002	Fitzgerald et al.	2004/0173815 A1	9/2004	Yeo et al.
2002/0123167 A1	9/2002	Fitzgerald et al.	2004/0175893 A1	9/2004	Vatus et al.
2002/0123182 A1	9/2002	Rabkin et al.	2004/0217430 A1	11/2004	Chu
2002/0123183 A1	9/2002	Fitzgerald	2004/0219726 A1	11/2004	Fitzgerald
2002/0123197 A1	9/2002	Fitzgerald et al.	2004/0253774 A1	12/2004	Boyanov et al.
2002/0125471 A1	9/2002	Fitzgerald et al.	2004/0253776 A1	12/2004	Hoffmann et al.
2002/0125497 A1	9/2002	Fitzgerald	2004/0262631 A1	12/2004	Fitzgerald
2002/0140031 A1*	10/2002	Rim 257/347	2004/0262683 A1	12/2004	Bohr et al.
2002/0142524 A1	10/2002	En et al.	2005/0009263 A1	1/2005	Yeo et al.
2002/0167048 A1	11/2002	Tweet et al.	2005/0009288 A1	1/2005	Fitzgerald
2002/0168864 A1	11/2002	Cheng et al.	2005/0156169 A1	7/2005	Chu
2002/0190284 A1	12/2002	Murthy et al.	2005/0156180 A1	7/2005	Zhang et al.
2003/0003679 A1	1/2003	Doyle et al.	2005/0161711 A1	7/2005	Chu
2003/0013305 A1	1/2003	Sugii et al.	2005/0167652 A1	8/2005	Hoffmann et al.
2003/0013323 A1	1/2003	Hammond et al.	2005/0250298 A1	11/2005	Bauer
2003/0025131 A1	2/2003	Lee et al.	2005/0277272 A1	12/2005	Singh et al.
2003/0027381 A1	2/2003	Buynoski et al.	2005/0280026 A1	12/2005	Isaacson et al.
2003/0034529 A1	2/2003	Fitzgerald et al.	2005/0280098 A1	12/2005	Shin et al.
2003/0057439 A1	3/2003	Fitzgerald	2006/0003510 A1	1/2006	Kammler et al.
2003/0077867 A1	4/2003	Fitzgerald	2006/0008958 A1	1/2006	Yeo et al.
2003/0080361 A1	5/2003	Murthy et al.	2006/0009001 A1	1/2006	Huang et al.
2003/0089901 A1	5/2003	Fitzgerald	2006/0057825 A1	3/2006	Bude et al.
2003/0102498 A1	6/2003	Braithwaite et al.			
2003/0113971 A1	6/2003	Nagaoka et al.			
2003/0119280 A1	6/2003	Lee et al.			
2003/0127646 A1	7/2003	Christiansen et al.	EP	0 828 296	3/1998
2003/0139000 A1	7/2003	Bedell et al.	EP	0 829 908	3/1998
2003/0141548 A1*	7/2003	Anderson et al. 257/353	EP	0 838 858	4/1998
2003/0157787 A1	8/2003	Murthy et al.	EP	1 020 900	7/2000
2003/0160300 A1	8/2003	Takenaka et al.	EP	1 174 928	1/2002
2003/0162348 A1	8/2003	Yeo et al.	FR	2 701 599	9/1993
2003/0178681 A1	9/2003	Clark et al.	FR	2 701 599	8/1994
2003/0189229 A1	10/2003	Mouli	GB	2 342 777	4/2000
2003/0199126 A1	10/2003	Chu et al.	JP	61-141116	6/1986
2003/0201458 A1	10/2003	Clark et al.	JP	2-210816	8/1990
2003/0203600 A1	10/2003	Chu et al.	JP	3-036717	2/1991
2003/0207127 A1	11/2003	Murthy et al.	JP	4-74415	3/1992
2003/0215990 A1	11/2003	Fitzgerald et al.	JP	4-307974	10/1992
2003/0218189 A1	11/2003	Christiansen et al.	JP	5-166724	7/1993
2003/0219957 A1	11/2003	Kuwabara et al.	JP	6-177046	6/1994
2003/0227029 A1	12/2003	Lochtefeld et al.	JP	6-244112	9/1994
2003/0227036 A1	12/2003	Sugiyama et al.	JP	06-252046	9/1994
2003/0227057 A1	12/2003	Lochtefeld et al.	JP	7-094420	4/1995
2003/0230778 A1	12/2003	Park et al.	JP	7-94420	4/1995
2003/0232467 A1	12/2003	Anderson et al.	JP	7-106446	4/1995

FOREIGN PATENT DOCUMENTS

JP	7-240372	9/1995
JP	9-219524	8/1997
JP	10-270685	10/1998
JP	11-233744	8/1999
JP	2000-021783	1/2000
JP	2000-31491	1/2000
JP	2001319935	5/2000
JP	2002-076334	3/2002
JP	2002-164520	6/2002
JP	2002-324765	8/2002
JP	2002-289533	10/2002
WO	WO 98/59365	12/1998
WO	WO 99/53539	10/1999
WO	WO 00/48239	8/2000
WO	WO 00/54338	9/2000
WO	WO 01/22482	3/2001
WO	WO 01/54202	7/2001
WO	WO 01/93338	12/2001
WO	WO 01/99169 A2	12/2001
WO	WO 02/13262	2/2002
WO	WO 02/15244 A2	2/2002
WO	WO 02/27783 A1	4/2002
WO	WO0243151 A *	5/2002
WO	WO 02/47168	6/2002
WO	WO 02/071488	9/2002
WO	WO 02/071491	9/2002
WO	WO 02/071495 A1	9/2002
WO	WO 02/082514 A1	10/2002
WO	WO 2004/006311 A2	1/2004
WO	WO 2004/006326 A1	1/2004
WO	WO 2004/006327 A2	1/2004
WO	WO 2004/019403 A2	3/2004
WO	WO 2004/019404 A2	3/2004

OTHER PUBLICATIONS

Armstrong et al., "Design of Si/SiGe Heterojunction Complementary Metal-Oxide-Semiconductor Transistors," *IEDM Technical Digest* (1995) pp. 761-764.

Armstrong, "Technology for SiGe Heterostructure-Based CMOS Devices", PH.D Thesis, Massachusetts Institute of Technology (1999) pp. 1-154.

Augusto et al., "Proposal for a New Process Flow for the Fabrication of Silicon-Based Complementary MOD-MOSFETs without Ion Implantation," *Thin Solid Films*, vol. 294, No. 1-2 (1997) pp. 254-258.

Barradas et al., "RBS analysis of MBE-grown SiGe/(001) Si heterostructures with thin, high Ge content SiGe channels for HMOS transistors," *Modern Physics Letters B* (2001) (abstract).

Batterman, "Hillocks, Pits, and Etch Rate in Germanium Crystals," *Journal of Applied Physics*, vol. 28, No. 11 (Nov. 1957), pp. 1236-1241.

Bohg, "Ethylene Diamine-Pyrocatechol-Water Mixture Shows Etching Anomaly in Boron-Doped Silicon," *Journal of the Electrochemical Society*, vol. 118, No. 2 (Feb. 1971), pp. 401-402.

Borenstein et al., "A New Ultra-Hard Etch-Stop Layer for High Precision Micromachining," *Proceedings of the 1999 12th IEEE International Conference on Micro Electro Mechanical Systems (MEMS)* (Jan. 17-21, 1999) pp. 205-210.

Bouillon et al., "Search for the optimal channel architecture for 0.18/0.12 μm bulk CMOS Experimental study," *IEEE* (1996) pp. 21.2.1-21.2.4.

Brunner et al., "Molecular beam epitaxy growth and thermal stability of $\text{Si}_{1-x}\text{Ge}_x$ layers on extremely thin silicon-on-insulator substrates," *Thin Solid Films*, vol. 321 (1998), pp. 245-250.

Bufler et al., "Hole transport in strained $\text{Si}_{1-x}\text{Ge}_x$ alloys on Si-yGe substrates," *Journal of Applied Physics*, vol. 84, No. 10 (Nov. 15, 1998) pp. 5597-5602.

Burghartz et al., "Microwave Inductors and Capacitors in Standard Multilevel Interconnect Silicon Technology," *IEEE Transactions on Microwave Theory and Techniques*, vol. 44, No. 1 (Jan. 1996) pp. 100-104.

Canaperi et al., "Preparation of a relaxed Si-Ge layer on an insulator in fabricating high-speed semiconductor devices with strained epitaxial films," International Business Machines Corporation, USA (2002) (abstract).

Carlin et al., "High Efficiency GaAs-on-Si Solar Cells with High Voc Using Graded GeSi Buffers," *IEEE* (2000) pp. 1006-1011.

Chang et al., "Selective Etching of SiGe/Si Heterostructures," *Journal of the Electrochemical Society*, No. 1 (Jan. 1991) pp. 202-204.

Chen et al., "The Band Model and the Etching Mechanism of Silicon in Aqueous KOH," *Journal of the Electrochemical Society*, vol. 142, No. 1 (Jan. 1995), pp. 170-176.

Cheng et al., "Electron Mobility Enhancement in Strained-Si n-MOSFETs Fabricated on SiGe-on-Insulator (SGOI) Substrates," *IEEE Electron Device Letters*, vol. 22, No. 7 (Jul. 2001) pp. 321-323.

Cheng et al., "Relaxed Silicon-Germanium on Insulator Substrate by Layer Transfer," *Journal of Electronic Materials*, vol. 30, No. 12 (2001) pp. L37-L39.

Cullis et al., "Growth ripples upon strained SiGe epitaxial layers on Si and misfit dislocation interactions," *Journal of Vacuum Science and Technology A*, vol. 12, No. 4 (Jul./Aug. 1994) pp. 1924-1931.

Currie et al., "Controlling Threading Dislocation in Ge on Si Using Graded SiGe Layers and Chemical-Mechanical Polishing," vol. 72 No. 14 (Apr. 6, 1998) pp. 1718-1720.

Currie et al., "Carrier mobilities and process stability of strained Si N- and p-MOSFETs on SiGe virtual substrates," *J. Vac. Sci. Technol. B.*, vol. 19, No. 6 (Nov./Dec. 2001) pp. 2268-2279.

Desmond et al., "The Effects of Process-Induced Defects on the Chemical Selectivity of Highly Doped Boron Etch Stops in Silicon," *Journal of the Electrochemical Society*, vol. 141, No. 1 (Jan. 1994), pp. 178-184.

Eaglesham et al., "Dislocation-Free Stanski-Krastanow Growth of Ge on Si(100)," *Physical Review Letters*, vol. 64, No. 16 (Apr. 16, 1990) pp. 1943-1946.

Ehman et al., "Morphology of Etch Pits on Germanium Studied by Optical and Scanning Electron Microscopy," *Journal of Applied Physics*, vol. 41, No. 7 (Jun. 1970), pp. 2824-2827.

Examination Report for European Patent Application No. 98 931 529.6-2203, dated Jan. 10, 2002, 4 pages.

Examination Report for European Patent Application No. 98 931 529.6-2203, dated May 9, 2003, 5 pages.

Examination Report for European Patent Application No. 01 973 651.1-1528, dated Mar. 22, 2004, 3 pages.

Examination Report for European Patent Application No. 01 989 893.1-1235, dated Aug. 16, 2004, 5 pages.

Examination Report for European Patent Application No. 01 973 651.1-1528, dated Nov. 12, 2004, 9 pages.

Examination Report for European Patent Application No. 02 709 406.9-2203, dated May 11, 2004, 3 pages.

Examination Report for European Patent Application No. 02 709 406.9-2203, dated Mar. 24, 2005, 5 pages.

Feijóo et al., "Etch Stop Barriers in Silicon Produced by Ion Implantation of Electrically Non-Active Species," *Journal of the Electrochemical Society*, vol. 139, No. 8 (Aug. 1992), pp. 2309-2313.

Feijóo et al., "Epitaxial Si-Ge Etch Stop Layers with Ethylene Diamine Pyrocatechol for Bonded and Etchback Silicon-on-Insulator," *Journal of Electronic Materials*, vol. 23, No. 6 (Jun. 1994) pp. 493-496.

Finne et al., "A Water-Amine-Complexing Agent System for Etching Silicon," *Journal of the Electrochemical Society*, vol. 114, No. 9 (Sep. 1967), pp. 965-970.

Fischetti et al., "Band structure, deformation potentials, and carrier mobility in strained Si, Ge, and SiGe alloys," *J. Appl. Phys.*, vol. 80, No. 4 (Aug. 15, 1996) pp. 2234-2252.

Fischetti, "Long-range Coulomb interactions in small Si devices. Part II. Effective electron mobility in thin-oxide structures," *Journal of Applied Physics*, vol. 89, No. 2 (Jan. 15, 2001) pp. 1232-1250.

Fitzgerald et al., "Dislocation dynamics in relaxed graded composition semiconductors," *Materials Science and Engineering B67* (1999) pp. 53-61.

Fitzgerald et al., "Dislocations in Relaxed SiGe/Si Heterostructures," *Physica Status Solidi A*, Applied Research, Berlin, DE, vol. 171, Nr. 1, pp. 227-238, Jan. 16, 1999.

- Fitzgerald, "GeSi/Si Nanostructures," *Annual Review of Materials Science*, vol. 25 (1995), pp. 417-454.
- Fitzgerald et al., "Relaxed $\text{Ge}_x\text{Si}_{1-x}$ structures for III-V integration with Si and high mobility two-dimensional electron gases in Si," AT&T Bell Laboratories, Murray Hill, NJ 07974 (1992) *American Vacuum Society*, pp. 1807-1819.
- Fitzgerald et al., "Totally Relaxed $\text{Ge}_x\text{Si}_{1-x}$ Layers with Low Threading Dislocation Densities Grown on Si Substrates," *Applied Physics Letters*, vol. 59, No. 7 (Aug. 12, 1991) pp. 811-813.
- Frank, "Orientation-Dependent Dissolution of Germanium," *Journal of Applied Physics*, vol. 31, No. 11 (Nov. 1960), pp. 1996-1999.
- Fukatsu, "SiGe-based semiconductor-on-insulator substrate created by low-energy separation-by-implanted-oxygen," *Applied Physics Letters*, vol. 72, No. 26 (Jun. 29, 1998), pp. 3485-3487.
- Gannavaram, et al., "Low Temperature ($\leq 800^\circ\text{C}$) Recessed Junction Selective Silicon-Germanium Source/Drain Technology for sub-70 nm CMOS," *IEEE International Electron Device Meeting Technical Digest*, (2000), pp. 437-440.
- Garone et al., "Silicon vapor phase epitaxial growth catalysis by the presence of germane," *Applied Physics Letters*, vol. 56, No. 13 (Mar. 26, 1990) pp. 1275-1277.
- Ge et al., "Process-Strained Si (PSS) CMOS Technology Featuring 3D Strain Engineering," *IEEE International Electron Devices Meeting Technical Digest*, (2003) pp. 73-76.
- Ghandi et al., "Chemical Etching of Germanium," *Journal of the Electrochemical Society*, vol. 135, No. 8 (Aug. 1988), pp. 2053-2054.
- Ghani et al., "A 90nm High Volume Manufacturing Logic Technology Featuring Novel 45nm Gate Length Strained Silicon CMOS Transistors," *IEEE International Electron Devices Meeting Technical Digest*, (2003), 978-980.
- Godbey et al., (1990) "Fabrication of Bond and Etch-Back Silicon Insulator Using a Strained $\text{Si}_{0.7}\text{Ge}_{0.3}$ Layer as an Etch Stop," *Journal of the Electrical Society*, vol. 137, No. 10 (Oct. 1990) pp. 3219-3223.
- Godbey et al., "A $\text{Si}_{0.7}\text{Ge}_{0.3}$ strained-layer etch stop for the generation of thin layer undoped silicon," *Applied Physics Letters*, vol. 56, No. 4 (Jan. 22, 1990), pp. 373-375.
- Gray and Meyer, "Phase-Locked Loops," *Analysis and Design of Analog Integrated Circuits* (1984) pp. 605-632.
- Grillot et al., "Acceptor diffusion and segregation in $(\text{Al}_x\text{Ga}_{1-x})_{0.5}\text{In}_{0.5}\text{P}$ heterostructures," *Journal of Applied Physics*, vol. 91, No. 8 (2002), pp. 4891-4899.
- Grützmacher et al., "Ge segregation in SiGe/Si heterostructures and its dependence on deposition technique and growth atmosphere," *Applied Physics Letters*, vol. 63, No. 18 (Nov. 1, 1993) pp. 2531-2533.
- Hackbarth et al., "Alternatives to thick MBE-grown relaxed SiGe buffers," *Thin Solid Films*, vol. 369, No. 1-2 (Jul. 2000) pp. 148-151.
- Hackbarth et al., "Strain relieved SiGe buffers for Si-based heterostructure field-effect transistors," *Journal of Crystal Growth*, vol. 201/202 (1999) pp. 734-738.
- Halsall et al., "Electron diffraction and Raman studies of the effect of substrate misorientation on ordering in the AlGaInP system," *Journal of Applied Physics*, vol. 85, No. 1 (1999), pp. 199-202.
- Hamada et al., "A New Aspect of Mechanical Stress Effects in Scaled MOS Devices," *IEEE Transactions on Electron Devices*, vol. 38, No. 4 (Apr. 1991), pp. 895-900.
- Herzog et al., "SiGe-based FETs: buffer issues and device results," *Thin Solid Films*, vol. 380 (2000) pp. 36-41.
- Herzog et al., "X-Ray Investigation of Boron- and Germanium-Doped Silicon Epitaxial Layers," *Journal of the Electrochemical Society*, vol. 131, No. 12 (Dec. 1984), pp. 2969-2974.
- Höck et al., "Carrier mobilities in modulation doped $\text{Si}_{1-x}\text{Ge}_x$ heterostructures with respect to FET applications," *Thin Solid Films*, vol. 336 (1998) pp. 141-144.
- Höck et al., "High hole mobility in $\text{Si}_{0.17}\text{Ge}_{0.83}$ channel metal-oxide-semiconductor field-effect transistors grown by plasma-enhanced chemical vapor deposition," *Applied Physics Letters*, vol. 76, No. 26 (Jun. 26, 2000) pp. 3920-3922.
- Hock et al., "High performance 0.25 μm p-type Ge/SiGe MODFETs," *Electronics Letters*, vol. 34, No. 19 (Sep. 17, 1998) pp. 1888-1889.
- Holmes, "The Orientation Dependence of Etching Effects on Germanium Crystals," *Acta Metallurgica*, vol. 7, No. 4 (Apr. 1959), pp. 283-290.
- Hsu et al., "Surface morphology of related $\text{Ge}_x\text{Si}_{1-x}$ films," *Appl. Phys. Lett.*, vol. 61, No. 11 (1992), pp. 1293-1295.
- Huang et al., (2001) "Carrier Mobility enhancement in strained Si-on-insulator fabricated by wafer bonding," *2001 Symposium on VLSI Technology, Digest of Technical Papers*, pp. 57-58.
- Huang et al., "Isolation Process Dependence of Channel Mobility in Thin-Film SOI Devices," *IEEE Electron Device Letters*, vol. 17, No. 6 (Jun. 1996), pp. 291-293.
- Huang et al., "LOCOS-Induced Stress Effects on Thin-Film SOI Devices," *IEEE Transactions on Electron Devices*, vol. 44, No. 4 (Apr. 1997), pp. 646-650.
- Huang, et al., "Reduction of Source/Drain Series Resistance and Its Impact on Device Performance for PMOS Transistors with Raised $\text{Si}_{1-x}\text{Ge}_x$ Source/Drain," *IEEE Electron Device Letters*, vol. 21, No. 9, (Sep. 2000) pp. 448-450.
- Huang et al., "The Impact of Scaling Down to Deep Submicron on CMOS RF Circuits," *IEEE Journal of Solid-State Circuits*, vol. 33, No. 7, Jul. 1998, pp. 1023-1036.
- Hunt et al., "Highly Selective Etch Stop by Stress Compensation for Thin-Film BESOI," *1990 IEEE/SOI Technology Conference*, (Oct. 2-4, 1990), pp. 145-146.
- IBM Technical Disclosure Bulletin, vol. 32, No. 8A, Jan. 1990, "Optimal Growth Technique and Structure for Strain Relaxation of Si-Ge Layers on Si Substrates," pp. 330-331.
- Iida et al., "Thermal behavior of residual strain in silicon-on-insulator bonded wafer and effects on electron mobility," *Solid-State Electronics*, vol. 43 (1999), pp. 1117-1120.
- International Search Report for Patent Application No. PCT/US 98/13076, dated Oct. 27, 1998, 2 pages.
- International Search Report for Related International Application No. PCT/US/18007, Jan. 5, 2004.
- Ishikawa et al., "SiGe-on-insulator substrate using SiGe alloy grown Si(001)," *Applied Physics Letters*, vol. 75, No. 7 (Aug. 16, 1999) pp. 983-985.
- Ismail et al., "Modulation-doped n-type Si/SiGe with inverted interface," *Appl. Phys. Lett.*, vol. 65, No. 10 (Sep. 5, 1994) pp. 1248-1250.
- Ismail, "Si/SiGe High-Speed Field-Effect Transistors," *Electron Devices Meeting, Washington, D.C.* (Dec. 10, 1995) pp. 20.1.1-20.1.4.
- Ito et al., "Mechanical Stress Effect on Etch-Stop Nitride and its Impact on Deep Submicron Transistor Design," *IEEE International Electron Devices Meeting Technical Digest*, (2000), pp. 247-250.
- Jaccodine, "Use of Modified Free Energy Theorems to Predict Equilibrium Growing and Etching Shapes," *Journal of Applied Physics*, vol. 33, No. 8 (Aug. 1962), pp. 2643-2647.
- Kearney et al., "The effect of alloy scattering on the mobility of holes in a $\text{Si}_{1-x}\text{Ge}_x$ quantum well," *Semicond. Sci Technol.*, vol. 13 (1998) pp. 174-180.
- Kern, "Chemical Etching of Silicon, Germanium, Gallium, Arsenide, and Gallium Phosphide," *RCA Review*, vol. 39 (Jun. 1978), pp. 278-308.
- Kim et al., "A Fully Integrated 1.9-GHz CMOS Low-Noise Amplifier," *IEEE Microwave and Guided Wave Letters*, vol. 8, No. 8 (Aug. 1998) pp. 293-295.
- Klauk et al., "Thermal stability of undoped strained Si channel SiGe heterostructures," *Applied Physics Letter*, No. 68, Apr. 1, 1996. pp. 1975-1977.
- Koester et al., "Extremely High Transconductance Ge/Si_{0.4}Ge_{0.6} p-MODFET's Grown by UHV-CVD," *IEEE Electron Device Letters*, vol. 21, No. 3 (Mar. 2000) pp. 110-112.
- König et al., "p-Type Ge-Channel MODFET's with High Transconductance Grown on Si Substrates," *IEEE Electron Device Letters*, vol. 14, No. 4 (Apr. 1993) pp. 205-207.
- König et al., "SiGe HBTs and HFETs," *Solid-State Electronics*, vol. 38, No. 9 (1995) pp. 1595-1602.
- Kunznetsov et al., "Technology for high-performance n-channel SiGe modulation-doped field-effect transistors," *J. Vac. Sci. Technol.*, B 13(6) (Nov./Dec. 1995) pp. 2892-2896.

- Lang et al., "Bulk Micromachining of Ge for IR Gratings," *Journal of Micromechanics and Microengineering*, vol. 6, No. 1 (Mar. 1996), pp. 46-48.
- Langdo et al., (2002) "Preparation of Novel SiGe-free Strained Si on Insulator Substrates" *IEEE International SOI Conference*, pp. 211-212 (XP002263057).
- Larson, "Integrated Circuit Technology Options for RFIC's—Present Status and Future Directions," *IEEE Journal of Solid-State Circuits*, vol. 33, No. 3, Mar. 1998, pp. 387-399.
- Leancu et al., "Anisotropic Etching of Germanium," *Sensors and Actuators*, A46-47 (1996), pp. 35-37.
- Lee et al., "CMOS RF Integrated Circuits at 5 GHz and Beyond," *Proceedings of the IEEE*, vol. 88, No. 10 (Oct. 2000) pp. 1560-1571.
- Lee et al., "Strained Ge channel p-type metal-oxide-semiconductor field-effect transistors grown on Si_{1-x}Ge_x/Si virtual substrates," *Applied Physics Letters*, vol. 79, No. 20 (Nov. 12, 2001) pp. 3344-3346.
- Lee et al., "Strained Ge channel p-type MOSFETs fabricated on Si_{1-x}Ge_x/Si virtual substrates," *Mat. Res. Soc. Symp. Proc.*, vol. 686 (2002) pp. A1.9.1-A1.9.5.
- LeGoues et al., "Relaxation of SiGe thin films grown on Si/SiO₂ substrates," *Applied Physics Letters*, vol. 75, No. 11 (Jun. 1, 1994), pp. 7240-7246.
- Lehmann et al., "Implanted Carbon: An Effective Etch-Stop in Silicon," *Journal of the Electrochemical Society*, vol. 138, No. 5 (May 1991), pp. 3-4.
- Leitz et al., "Channel Engineering of SiGe-Based Heterostructures for High Mobility MOSFETs," *Mat. Res. Soc. Symp. Proc.*, vol. 686 (2002) pp. A3.10.1-A3.10.6.
- Leitz et al., "Dislocation glide and blocking kinetics in compositionally graded SiGe/Si," *Journal of Applied Physics*, vol. 90, No. 6 (Sep. 15, 2001) pp. 2730-2736.
- Leitz et al., "Hole mobility enhancements in strained Si/Si_{1-y}Ge_y p-type metal-oxide-semiconductor field-effect transistors grown on relaxed Si_{1-x}Ge_x (x<y) virtual substrates," *Applied Physics Letters*, vol. 79, No. 25 (Dec. 17, 2001) pp. 4246-4248.
- Li et al., "Design of high speed Si/SiGe heterojunction complementary metal-oxide-semiconductor field effect transistors with reduced short-channel effects," *J. Vac. Sci. Technol.*, vol. 20 No. 3 (May/Jun. 2002) pp. 1030-1033.
- Lochtefeld et al., "Investigating the Relationship Between Electron Mobility and Velocity in Deeply Scaled NMOS via Mechanical Stress," *IEEE Electron Device Letters*, vol. 22, No. 12 (2001), pp. 591-593.
- Lu et al., "High Performance 0.1 μm Gate-Length P-Type SiGe MODFET's and MOS-MODFET's," *IEEE Transactions on Electron Devices*, vol. 47, No. 8 (Aug. 2000) pp. 1645-1652.
- König et al., "Design Rules for n-Type SiGe Hetero FETs," *Solid State Electronics*, vol. 41, No. 10 (1997), pp. 1541-1547.
- Kummer et al., "Low energy enhanced chemical vapor deposition," *Materials Science and Engineering B89* (2002) pp. 288-295.
- Maiti et al., "Strained-Si heterostructure field effect transistors," *Semicond. Sci. Technol.*, vol. 13 (1998) pp. 1225-1246.
- Maszara, "Silicon-On-Insulator by Wafer Bonding: A Review," *Journal of the Electrochemical Society*, No. 1 (Jan. 1991) pp. 341-347.
- Meyerson et al., "Cooperative Growth Phenomena in Silicon/Germanium Low-Temperature Epitaxy," *Applied Physics Letters*, vol. 53, No. 25 (Dec. 19, 1988) pp. 2555-2557.
- Mizuno et al., "Advanced SOI-MOSFETs with Strained-Si Channel for High Speed CMOS-Electron/Hole Mobility Enhancement," 2000 Symposium on VLSI Technology, Digest of Technical Papers, Honolulu, (Jun. 13-15), IEEE New York, NY, pp. 210-211.
- Mizuno et al., "Electron and Hole Mobility Enhancement in Strained-Si MOSFET's on SiGe-on-Insulator Substrates Fabricated by SIMOX Technology," *IEEE Electron Device Letters*, vol. 21, No. 5 (May 2000) pp. 230-232.
- Mizuno et al., "High Performance Strained-Si p-MOSFETs on SiGe-on-Insulator Substrates Fabricated by SIMOX Technology," *IEEE IEDM Technical Digest* (1999) pp. 934-936.
- Narozny et al., "Si/SiGe Heterojunction Bipolar Transistor with Graded GAP SiGe Base Made by Molecular Beam Epitaxy," *IEEE IEDM* (1988), pp. 562-565.
- Nayak et al., "High-Mobility Strained-Si PMOSFET's"; *IEEE Transactions on Electron Devices*, vol. 43, No. 10 (Oct. 1996) pp. 1709-1716.
- Notice of Preliminary Rejection for Korean Patent Application No. 10-1999-7012279, dated Feb. 21, 2002, 2 pages (English translation attached).
- Notice of Final Rejection for Korean Patent Application No. 10-1999-7012279, dated Feb. 25, 2003 2 pages (English translation attached).
- O'Neill et al., "SiGe Virtual substrate N-channel heterojunction MOSFETs," *Semicond. Sci. Technol.*, vol. 14 (1999) pp. 784-789.
- Ootsuka et al., "A Highly Dense, High-Performance 130nm node CMOS Technology for Large Scale System-on-a-Chip Applications," *IEEE International Electron Devices Meeting Technical Digest*, (2000), pp. 575-578.
- Ota, Y. et al., "Application of heterojunction FET to power amplifier for cellular telephone," *Electronics Letters*, vol. 30, No. 11 (May 26, 1994) pp. 906-907.
- Ota et al., "Novel Locally Strained Channel Technique for High Performance 55nm CMOS," *IEEE International Electron Devices Meeting Technical Digest*, (2002), pp. 27-30.
- Öztürk, et al., "Advanced Si_{1-x}Ge_x Source/Drain and Contact Technologies for Sub-70 nm CMOS," *IEEE International Electron Device Meeting Technical Digest*, (2002), pp. 375-378.
- Öztürk, et al., "Low Resistivity Nickel Germanosilicide Contacts to Ultra-Shallow Si_{1-x}Ge_x Source/Drain Junctions for Nanoscale CMOS," *IEEE International Electron Device Meeting Technical Digest* (2003), pp. 497-500.
- Öztürk, et al., "Selective Silicon-Germanium Source/Drain Technology for Nanoscale CMOS," *Mat. Res. Soc. Symp. Proc.*, vol. 717, (2002), pp. C4.1.1-C4.1.12.
- Öztürk, et al., "Ultra-Shallow Source/Drain Junctions for Nanoscale CMOS Using Selective Silicon-Germanium Technology," *Extended Abstracts of International Workshop on Junction Technology*, (2001), pp. 77-82.
- Palik et al., "Ellipsometric Study of the Etch-Stop Mechanism in Heavily Doped Silicon," *Journal of the Electrochemical Society*, vol. 132, No. 1 (Jan. 1985), pp. 135-141.
- Palik et al. "Study of Bias-Dependent Etching of Si in Aqueous KOH," *Journal of the Electrochemical Society*, vol. 134, No. 2 (Feb. 1987), pp. 404-409.
- Palik et al., "Study of the Etch-Stop Mechanism in Silicon," *Journal of the Electrochemical Society*, vol. 129, No. 9 (Sep. 1982), pp. 2051-2059.
- Papananos, "Low Noise Amplifiers in MOS Technologies," and "Low Noise Tuned-LC Oscillator," *Radio-Frequency Microelectronic Circuits for Telecommunication Applications* (1999) pp. 115-117, 188-193.
- Parker et al., "SiGe heterostructure CMOS circuits and applications," *Solid State Electronics*, vol. 43 (1999) pp. 1497-1506.
- Petersen, "Silicon as a Mechanical Material," *Proceedings of the IEEE*, vol. 70, No. 5 (May 1982), pp. 420-457.
- Powell et al., "New approach to the growth of low dislocation relaxed SiGe material," *Applied Physics Letters*, vol. 64, No. 14 (Apr. 4, 1994), pp. 1865-1858.
- Rai-Choudhury et al., "Doping of Epitaxial Silicon," *Journal of Crystal Growth*, vol. 7 (1970), pp. 361-367.
- Raley et al., "(100) Silicon Etch-Rate Dependence on Boron Concentration in Ethylenediamine-Pyrocatechol-Water Solutions," *Journal of the Electrochemical Society*, vol. 131, No. 1 (Jan. 1984), pp. 161-170.
- Ransom et al., "Gate-Self-Aligned n-channel and p-channel Germanium MOSFET's," *IEEE Transactions on Electron Devices*, vol. 38, No. 12 (Dec. 1991) pp. 2695.
- Reinking et al., "Fabrication of high-mobility Ge p-channel MOSFETs on Si substrates," *Electronics Letters*, vol. 35, No. 6 (Mar. 18, 1999) pp. 503-504.
- Rim et al., "Enhanced Hole Mobilities in Surface-channel Strained-Si p-MOSFETs"; *IEDM*, 1995, pp. 517-520.
- Rim, "Application of Silicon-Based Heterostructures to Enhanced Mobility Metal-Oxide-Semiconductor Field-Effect Transistors", PH.D. Thesis, Stanford University (1999) pp. 1-184.

- Robbins et al., "A model for heterogeneous growth of $\text{Si}_{1-x}\text{Ge}_x$ films for hydrides," *Journal of Applied Physics*, vol. 69, No. 6 (Mar. 15, 1991) pp. 3729-3732.
- Rosenblad et al., "Strain relaxation of graded SiGe buffers grown at very high rates," *Materials Science and Engineering B*, Elsevier Sequoia, Lausanne, CH, vol. 71, Nr. 1-3, p. 20-23, Feb. 2000.
- Sadek et al., "Design of Si/SiGe Heterojunction Complementary Metal-Oxide-Semiconductor Transistors," *IEEE Trans. Electron Devices* (Aug. 1996) pp. 1224-1232.
- Sakaguchi et al., "ELTRAN® by Splitting Porous Si Layers," Proc. 195th Int. SOI Symposium, vol. 99-3, *Electrochemical Society* (1999) pp. 117-121.
- Schäffler, "High-Mobility Si and Ge Structures," *Semiconductor Science and Technology*, vol. 12 (1997) pp. 1515-1549.
- Seidel et al., "Anisotropic Etching of Crystalline Silicon in Alkaline Solutions," *Journal of the Electrochemical Society*, vol. 137, No. 11 (Nov. 1990), pp. 3626-3632.
- Senna et al., "Gallium Doping for Silicon Etch Stop in KOH," *Transducers on Solid-State Sensors and Actuators and Eurosensors IX*, Stockholm, Sweden, Jun. 25-29, 1995, pp. 194-195.
- Shang et al., "The Development of an Anisotropic Si Etch Process Selective to $\text{Ge}_x\text{Si}_{1-x}$ Underlayers," *Journal of the Electrochemical Society*, vol. 141, No. 2 (Feb. 1994), pp. 507-510.
- Shimizu et al., "Local Mechanical-Stress Control (LMC): A New Technique for CMOS-Performance Enhancement," *IEEE International Electron Devices Meeting Technical Digest*, (2001), pp. 433-436.
- Soderbarg, "Fabrication of BESOI-Materials Using Implanted Nitrogen as an Effective Etch Stop Barrier," *1989 IEEE SOS/SOI Technology Conference*, (Oct. 3-5, 1989), pp. 64.
- Sugimoto et al., "A 2V, 500 MHz and 3V, 920 MHz Low-Power Current-Mode 0.6 μm CMOS VCO Circuit," *IEICE Trans. Electron.*, vol. E82-C, No. 7 (Jul. 1999) pp. 1327-1329.
- Sundaram et al., "Electrochemical etching of Silicon by Hydrazine," *Journal of the Electrochemical Society*, vol. 140, No. 6 (Jun. 1993), pp. 1592-1597.
- Sze, "Physics of Semiconductor Devices," (1991).
- Takagi et al., "On the Universality of Inversion Layer Mobility in Si MOSFET's: Part I-Effects of Substrate Impurity Concentration," *IEEE Transactions on Electron Devices*, vol. 41, No. 12 (Dec. 1994), pp. 2357-2362.
- Ternent et al., "Metal Gate Strained Silicon MOSFETs for Microwave Integrated Circuits," *IEEE* (Oct. 2000) pp. 38-43.
- Thompson et al., "A Logic Nanotechnology Featuring Strained-Silicon," *IEEE Electron Device Letters*, vol. 25, No. 4 (Apr. 2004), pp. 191-193.
- Thompson et al., "A 90 nm Logic Technology Featuring 50nm Strained-Silicon Channel Transistors, 7 layers of Cu Interconnects, Low k ILD, and 1um² SRAM Cell," *IEEE International Electron Devices Meeting Technical Digest*, (2002), pp. 61-64.
- Ting et al., "Monolithic Integration of III-V Materials and Devices on Silicon," Part of the SPIE Conference on Silicon-Based Optoelectronics, San Jose, CA, (Jan. 1999), pp. 19-28.
- Tiwari et al., "Hole Mobility Improvement in Silicon-on-Insulator and Bulk Silicon Transistors Using Local Strain," *IEEE International Electron Devices Meeting Technical Digest*, (1997), pp. 939-941.
- Tsang et al., "Measurements of alloy composition and strain in thin $\text{Ge}_x\text{Si}_{1-x}$ layers," *J. Appl. Phys.*, vol. 75 No. 12 (Jun. 15, 1994) pp. 8098-8108.
- Tweet et al., "Factors determining the composition of strained GeSi layers grown with disilane and germane," *Applied Physics Letters*, vol. 65, No. 20 (Nov. 14, 1994) pp. 2579-2581.
- Uchino, et al., "A Raised Source/Drain Technology Using In-situ P-doped SiGe and B-doped Si for 0.1- μm CMOS ULSIs," *IEEE International Electron Device Meeting Technical Digest*, (1997), pp. 479-482.
- Usami et al., "Spectroscopic study of Si-based quantum wells with neighboring confinement structure," *Semicon. Sci. Technol.* (1997) (abstract).
- Vol'fson et al., "Fundamental Absorption Edge of Silicon Heavily Doped with Donor or Acceptor Impurities," *Soviet Physics Semiconductors*, vol. 1, No. 3 (Sep. 1967), pp. 327-332.
- Welser et al., "Electron Mobility Enhancement in Strained-Si N-Type Metal-Oxide-Semiconductor Field-Effect Transistors," *IEEE Electron Device Letters*, vol. 15, No. 3 (Mar. 1994) pp. 100-102.
- Welser et al., "Evidence of Real-Space Hot-Electron Transfer in High Mobility, Strained-Si Multilayer MOSFETs," *IEEE IDEM Technical Digest* (1993) pp. 545-548.
- Welser et al., "NMOS and PMOS Transistors Fabricated in Strained Silicon/Relaxed Silicon-Germanium Structures," *IEEE IDEM Technical Digest* (1992) pp. 1000-1002.
- Welser, "The Application of Strained Silicon/Relaxed Silicon Germanium Heterostructures to Metal-Oxide-Semiconductor Field-Effect Transistors," PH.D. Thesis, Stanford University (1994) pp. 1-205.
- Wolf et al., "Silicon Processing for the VLSI Era," *Process Technology* (1986) pp. 384-386.
- Wu, "Novel Etch-Stop Materials for Silicon Micromachining," Thesis Submitted to the Massachusetts Institute of Technology Department of Materials Science and Engineering on May 9, 1997, pp. 1-62.
- Xie et al., "Semiconductor Surface Roughness: Dependence on Sign and Magnitude of Bulk Strain," *The Physical Review Letters*, vol. 73, No. 22 (Nov. 28, 1994) pp. 3006-3009.
- Xie et al., "Very high mobility two-dimensional hole gas in Si/Ge_xSi_{1-x}/Ge structures grown by molecular beam epitaxy," *Appl. Phys. Lett.*, vol. 63, No. 16 (Oct. 18, 1993) pp. 2263-2264.
- Xie, "SiGe Field effect transistors," *Materials Science and Engineering*, vol. 25 (1999) pp. 89-121.
- Yamagata et al., "Bonding, Splitting and Thinning by Porous Si in ELTRAN®; SOI-Epi Wafer™," *Mat. Res. Soc. Symp. Proc.*, vol. 681E (2001) pp. 18.2.1-18.2.10.
- Yeo et al., "Nanoscale Ultra-Thin-Body Silicon-on-Insulator P-MOSFET with a SiGe/Si Heterostructure Channel," *IEEE Electron Device Letters*, vol. 21, No. 4 (Apr. 2000) pp. 161-163.
- Yi et al., "Si_{1-x}Ge_x/Si Multiple Quantum Well Wires Fabricated Using Selective Etching," *Materials Research Society Symposium Proceedings*, vol. 379 (1995), pp. 91-96.
- Zhang et al., "Demonstration of a GaAs-Based Compliant Substrate Using Wafer Bonding and Substrate Removal Techniques," *Electronic Materials and Processing Research Laboratory, Department of Electrical Engineering, University Park, PA 16802* (1998) pp. 25-28.
- Aldrich et al., "Stability of C54 Titanium Germanosilicide on a Silicon-Germanium Alloy Substrate," *Journal of Applied Physics*, vol. 77, No. 10 (1995) 5107-5114.
- Antoniadis et al., "SOI Devices and Technology," SOI devices and technology, Neuilly sur Seine, France, (1999), pp. 81-87.
- Aoyama et al., "Facet formation mechanism of silicon selective epitaxial layer by Si ultrahigh vacuum chemical vapor deposition," *Journal of Crystal Growth*, 136 (1994), pp. 349-354.
- Arst et al., "Surface planarity and microstructure of low temperature silicon SEG and ELO," *Journal of Materials Research*, vol. 6, No. 4 (Apr. 1991), pp. 784-791.
- Aubry-Fortuna et al., "Phase Formation and Strain Relaxation During Thermal Reaction of Zr and Ti with Strained Si_{1-x-y}Ge_xC_y Epilayers," *Journal of Applied Physics*, vol. 88, Iss. 3 (2000), 1418-1423.
- Augendre, "Elevated Source/Drain by Sacrificial Selective Epitaxy for High Performance Deep Submicron CMOS: Process Window versus Complexity," *IEEE Transactions on Electron Devices*, vol. 47, No. 7 (Jul. 2000), pp. 1484-1491.
- Bruel et al., "SMART CUT: A Promising New SOI Material Technology," *Proceedings of the 1995 IEEE International SOI Conference* (Oct. 1995), pp. 178-179.
- Bruel, "Silicon on Insulator Material Technology," *Electronic Letters*, vol. 31, No. 14 (Jul. 6, 1995), pp. 1201-1202.
- Cao et al., "0.18- μm Fully Depleted Silicon-on-Insulator MOSFET's," *IEEE Electron Device Letters*, vol. 18, No. 6 (Jun. 1997), pp. 251-253.
- Chieh et al., "Low-Resistance Bandgap-Engineered W/Si_{1-x}Ge_x/Si Contacts," *IEEE Electron Device Letters*, vol. 17, No. 7 (Jul. 1996) pp. 360-362.
- Choi et al., "30nm ultra-thin body SOI MOSFET with selectively deposited Ge raised S/D," 58th Device Research Conference (2000) pp. 23-24.

- Choi et al., "Nanoscale Ultrathin Body PMOSFETs With Raised Selective Germanium Source/Drain," *IEEE Electron Device Letters*, vol. 22, No. 9 (Sep. 2001), pp. 447-448.
- Detavernier et al., "CoSi₂ Nucleation in the Presence of Ge," *Thin Solid Films*, vol. 384, No. 2 (2001), pp. 243-250.
- Drowley et al., "Model for facet and sidewall defect formation during selective epitaxial growth of (001) silicon," *Applied Physics Letters*, 52 (7) (Feb. 15, 1988), pp. 546-548.
- Eaglesham et al., "Growth Morphology and the Equilibrium Shape: The Role of "Surfactants" in the Ge/Si Island Formation," *Physical Review Letters*, vol. 70, No. 7 (Feb. 15, 1993), pp. 966-969.
- Eberhart et al., "Ni/Ag Metallization for SiGe HBTs using a Ni Silicide Contact," *Semiconductor Science and Technology* vol. 16, No. 9, (2001) pp. L47-L49.
- Freiman et al., "Kinetics of Processes in the Ti-Si_{1-x}Ge_x Systems," *Applied Physics Letters* vol. 69, No. 25 (1996) pp. 3821-3823.
- Freiman et al., "Titanium Metallization of Si/Ge Alloys and Superlattices," *Thin Solid Films* vol. 294, No. 1-2 (1997) pp. 217-219.
- Gallas et al., "Influence of doping on facet formation at the SiO₂/Si interface," *Surface Science*, 440 (1999), pp. 41-48.
- Glück et al., "CoSi₂ and TiSi₂ for Si/SiGe heterodevices," *Thin Solid Films*, vol. 270 (1995) pp. 549-554.
- Goulding, "The selective epitaxial growth of silicon," *Materials Science and Engineering*, B17 (1993), pp. 47-67.
- Greve et al., "Growth Rate of Doped and Undoped Silicon by Ultra-High Vacuum Chemical Vapor Deposition," *Journal of the Electrochemical Society*, vol. 138, No. 6 (Jun. 1991), pp. 1744-1748.
- Hsiao et al., "Advanced Technologies for Optimized Sub-Quarter-Micrometer SOI CMOS Devices," *IEEE Transactions on Electron Devices*, vol. 45, No. 5 (1998) pp. 1092-1098.
- Huang et al., "Electrical and Compositional Properties of Co-Silicided Shallow P+-n Junction Using Si-Capped/Boron-Doped Si_{1-x}Ge_x Layer Deposited by UHVCME," *Journal of the Electrochemical Society*, vol. 148, No. 3 (2001) pp. G126-C131.
- Huang et al., "High-quality strain-relaxed SiGe alloy grown on implanted silicon-on-insulator substrate," *Applied Physics Letters*, vol. 76, No. 19 (May 8, 2000), pp. 2680-2682.
- Huang, et al., "Study on Ge/Si Ration Silidation, and Strain Relaxation of High Temperature Sputtered Co/Si_{1-x}Ge_x Structures," *Journal of Applied Physics*, vol. 88, No. 4 (2000) pp. 1831-1837.
- Ilderem et al., "Very low pressure chemical vapor deposition process for selective titanium silicide films," *Appl. Phys. Lett.*, vol. 53, No. 8 (Aug. 22, 1988) pp. 687-689.
- Ishikawa et al., "Creation of Si-Ge-based SIMOX structures by low energy oxygen implantation," *Proceedings of the 1997 IEEE International SOI Conference* (Oct. 1997), pp. 16-17.
- Ishitani et al., "Facet Formation in Selective Silicon Epitaxial Growth," *Japanese Journal of Applied Physics*, vol. 24, No. 10 (Oct. 1985), pp. 1267-1269.
- Jang et al., "Phosphorus doping of epitaxial Si and Si_{1-x}Ge_x at very low pressure," *Applied Physics Letters*, 63 (12) (Sep. 20, 1993), pp. 1675-1677.
- Jastrzebski, "SOI by CVD: Epitaxial Lateral Overgrowth (ELO) Process—Review," *Journal of Crystal Growth*, 63 (1983), pp. 493-526.
- Jungemann et al., "Full-Band Monte Carlo Simulation of a 0.12 μm-Si-PMOSFET with and without a Strained SiGe-Channel," *IEEE Electron Devices Meeting*, 1998, pp. 897-900.
- Kamins et al., "Kinetics of selective epitaxial deposition of Si_{1-x}Ge_x," *Applied Physics Letters*, 61 (6) (Aug. 10, 1992), pp. 669-671.
- Kandel et al., "Surfactant Mediated Crystal Growth of Semiconductors," *Physical Review Letters*, vol. 75, No. 14 (Oct. 2, 1995), pp. 2742-2745.
- King et al., "A Polycrystalline Si_{1-x}Ge_x-Gate CMOS Technology," *IEEE*, Volume, No., 1990, pp. 253-256.
- King, "Silicon-Germanium: from Microelectronics to Micromechanics," *Presentation to the Thin Film Users Group Meeting*, AVS Northern California Chapter, Apr. 17, 2002.
- Kitajima et al., "Lattice Defect in Selective Epitaxial Silicon and Laterally Overgrown Regions on SiO₂," *Journal of Crystal Growth*, 98 (1989), pp. 264-276.
- Ku et al., "High Performance PMOSFETS With Ni(Si_{1-x}Ge_x)/Poly-Si_{0.8}Ge_{0.2} Gate," *IEEE- 2000 Symposium on BLSI Technology Digest of Technical Papers*, pp. 114-115 (2000).
- Kurosawa et al., "A New Bird's Beak Free Field Isolation Technology for VLSI Devices," *IEDM Technical Digest*, Washington, D.C., Dec. 7-9, 1981, pp. 384-387.
- Lai, J.B. et al., "Effects of Composition on the Formation Temperatures and Electrical Resistivities of C54 Titanium Germanosilicide in Ti-Si_{1-x}Ge_x Systems," *Journal of Applied Physics*, vol. 86, No. 3 (1999) pp. 1340-1345.
- Langdo, "Selective SiGe Nanostructures," *PH.D. Thesis*, Massachusetts Institute of Technology, 2001.
- Li et al., "Modeling of facet growth on patterned Si substrate in gas source MBE," *Journal of Crystal Growth*, 157 (1995), pp. 185-189.
- Lochtefeld, "Toward the End of the MOSFET Roadmap: Investigating Fundamental Transport Limits and Device Architecture Alternatives," *PH.D. Thesis*, Massachusetts Institute of Technology, 2001.
- Lynch, "Self-Aligned Contact Schemes for Source-Drains in Submicron Devices," *IEDM Technical Digest* (1987) pp. 354-357.
- Maillard-Schaller et al., "Role of the substrate strain in the sheet resistance stability of NiSi deposited on Si(100)," *Journal of Applied Physics*, vol. 85, No. 7 (Apr. 1, 1999) pp. 3614-3618.
- Maiti et al., "Strained-Si Heterostructure Field Effect Transistors," *Semicond. Sci. Technol.*, vol. 13, pp. 1225-1246 (1998).
- Mercier et al., "Selective TiSi₂ Deposition with no Silicon Substrate Consumption by Rapid Thermal Processing in a LPCVD Reactor," *Journal of Electronic Materials*, vol. 19, No. 3 (1990) pp. 253-258.
- Meyer, "Elevated Source/Drain Structures," *The ASM Epitaxy Newsletter of Continuous Improvement*, (Spring 1998) pp. 1-3.
- Meyerson et al., "Phosphorus-Doped Polycrystalline Silicon via LPCVD," *Journal of the Electrochemical Society*, vol. 131, No. 10 (Oct. 1984), pp. 2366-2368.
- Miyano et al., "Facet-Free Si Selective Epitaxial Growth Adaptable to Elevated Source/Drain MOSFETs with Narrow Shallow Trench Isolation," *Japanese Journal of Applied Physics*. vol. 38, Part 1, No. 4B (Apr. 1999), pp. 2419-2423.
- Moon et al., "Application of interferometric broadband imaging alignment on an experimental x-ray stepper," *Journal of Vacuum Science and Technology*, B 16(6) (Nov./Dec. 1998), pp. 3631-3636.
- Okada et al., "Epitaxial Growth of Heavily B-Doped SiGe Films and Interfacial Reaction of Ti/B-Doped SiGe Bilayer Structure using Rapid Thermal Processing," *Thin Solid Films*, vol. 369, No. 1-2 (2000) pp. 130-133.
- Osburn et al., "Low parasitic resistance contacts for scaled ULSI devices," *Thin Solid Films*, 332 (1998), pp. 428-436.
- Öztürk et al., "Rapid Thermal Chemical Vapor Deposition of Germanium and Germanium/Silicon Alloys on Silicon: New Applications in the Fabrication of MOS Transistors," *Mat. Res. Soc. Symp. Proc.*, vol. 224 (1991) pp. 223-234.
- Pfiester et al., "A Self-Aligned Elevated Source/Drain MOSFET," *IEEE Electron Device Letters*, vol. 11, No. 9 (Sep. 1990), pp. 365-367.
- Ponomarev et al., "High-Performance Deep SubMicron CMOS Technologies with Polycrystalline-SiGe Gates," *IEEE Transactions on Electron Devices*, vol. 47, No. 4, Apr. 2000, pp. 848-855.
- Qin, et al., "Structure and Thermal Stability of Ni/Si_{1-x}Ge_x Contacts for VLSI Applications vol. 36, No. 21 (Oct. 2000) pp. 1819-1821.
- Raaijmakers et al., "Enabling technologies for forming and contacting shallow junctions in Si: HF-vapor cleaning and selective epitaxial growth of Si and SiGe," *Journal of Vacuum Science and Technology*, B 17(5) (Sep./Oct. 1999), pp. 2311-2320.
- Ren et al., "A Novel Implantation Free Raised Source/Drain MOSFET Process Using Selective Rapid Thermal Chemical Vapor Deposition of In-Situ Boron Doped Si_xGe_{1-x}," *Mat. Res. Soc. Symp. Proc.*, vol. 303 (1993) pp. 37-41.
- Reynolds et al., "Selective titanium disilicide by low-pressure chemical vapor deposition," *J. Appl. Phys.*, vol. 65, No. 8 (Apr. 15, 1989) pp. 3212-3218.
- Rim et al., "Fabrication and Analysis of Deep Submicron Strained-Si N-MOSFET's", *IEEE Transactions on Electron Devices*, vol. 47, No. 7, Jul. 2000, pp. 1406-1415.

- Rodder et al., "Raised Source/Drain MOSFET with Dual Sidewall Spacers," *IEEE Electron Device Letters*, vol. 12, No. 3 (Mar. 1991), pp. 89-91.
- Samavedam et al., "Elevated source drain devices using silicon selective epitaxial growth," *Journal of Vacuum Science and Technology, B* 18(3) (May/Jun. 2000), pp. 1244-1250.
- Savina et al., "Faceting of a growing crystal surface by surface diffusion," *Physical Review, E* 67, 021606 (2003), pp. 1-16.
- Sedgwick et al., "Growth of Facet-Free Selective Epitaxy at Low Temperature and Atmospheric Pressure," *Journal of the Electrochemical Society*, vol. 138, No. 10 (Oct. 1991), pp. 3042-3047.
- Shibata et al., "High Performance Half-Micron PMOSFETs with 0.1UM Shallow P+N Junction Utilizing Selective Silicon Growth and Rapid Thermal Annealing," *IEDM Technical Digest* (1987) pp. 590-593.
- Sidek et al., "Reduction of parasitic bipolar transistor action and punchthrough susceptibility in MOSFETs using Si/Si_{1-x}Ge_x sources and drains," *Electronics Letters*, vol. 32, No. 3 (Feb. 1, 1996), pp. 269-270.
- Sun et al., "A Comparative Study of n+/p Junction Formation for Deep Submicron Elevated Source/Drain Metal Oxide Semiconductor Field Effect Transistors," *Journal of the Electrochemical Society*, vol. 144, No. 10 (Oct. 1997), pp. 3659-3664.
- Sun et al., "The Effect of the Elevated Source/Drain Doping Profile on Performance and Reliability of Deep Submicron MOSFET's," *IEEE Transactions on Electron Devices*, vol. 44, No. 9 (Sep. 1997), pp. 1491-1498.
- Sun et al., "Impact of Epi Facets on Deep Submicron Elevated Source/Drain MOSFET Characteristics," *IEEE Transactions on Electron Devices*, vol. 45, No. 6 (Jun. 1998), pp. 1377-1380.
- Tromp et al., "Local Dimer Exchange in Surfactant-Mediated Epitaxial Growth," *Physical Review Letters*, vol. 68, No. 7 (Feb. 17, 1992), pp. 954-957.
- Uchino et al., "MOSFETs with Ultrashallow Junction and Minimum Drain Area Formed by Using Solid-Phase Diffusion from SiGe," *IEEE Transactions on Electron Devices*, vol. 48, No. 7 (Jul. 2001) pp. 1406-1411.
- Uhrberg et al., "Electronic and atomic structure of arsenic terminated Si(100)," *Journal of Vacuum Science and Technology, A* 4 (3) (May/Jun. 1986), pp. 1259-1264.
- Violette et al., "Facet-Free Selective Silicon Epitaxy by Reduced-Pressure Chemical Vapor Deposition: Process Evaluation and Impact on Shallow Trench Isolation," *Journal of the Electrochemical Society*, 146 (5) (1999), pp. 1895-1902.
- Wong et al., "Elevated Source/Drain MOSFET," *IEDM Technical Digest*, 28 (1984), pp. 634-637.
- Xiang et al., "Interfacial mass transport and facet evolution in selective epitaxial growth of Si by gas source molecular beam epitaxy," *Journal of Vacuum Science and Technology, B* 14(3) (May/Jun. 1996), pp. 2381-2386.
- Yasuda et al., "Interfacial Reactions of Ti / and Zr / Si_{1-x}Ge_x / Si Contacts with Rapid Thermal Annealing," *Thin Solid Films*, Volume/No. 373, 2000, pp. 73-78.
- Yew, "Growth and Characterization of Low Temperature Silicon Selective Epitaxy," PH.D. Thesis, MIT, 1990, pp. 1-210.
- Yu et al., "Doping reaction of PH₃ and B₂H₆ with Si(100)," *Journal of Applied Physics*, 59 (12) (Jun. 15, 1986), pp. 4032-4037.
- Abstreiter et al., "Silicon/Germanium Strained Layer Superlattices," *Journal of Crystal Growth*, 95:431-438 (1989).
- Ahlgren et al., "A SiGe HBT BICMOS Technology for Mixed-Signal RF Applications," 1977 *IEEE Bipolar/BiCMOS Circuits and Tech. Meeting* 195.
- Ahn et al., "Film Stress-Related Vacancy Supersaturation in Silicon Under Low-Pressure Chemical Vapor Deposited Silicon Nitride Films," 64 *J. App. Physics* 4914 (1988).
- AmberWave Systems Corporation's Second Supplemental Responses to Intel's Third Set of Interrogatories, U.S.D.C., District of Delaware, C.A. No. 05-301-KAJ (Jul. 12, 2006).
- Antonelli et al., "Pressure and Strain Effects on Diffusion," 163 *Materials Res. Soc'y Symp. Proc.* 523 (1989).
- Auberton-Hervé et al., "SMART CUT®: The Basic Fabrication Process for UNIBONOD® SOI Wafers," *IEICE Transactions on Electronics*, E80-C(3):358-363 (1997).
- Augendre et al., "Elevated Source/Drain by Sacrificial Selective Epitaxy for High Performance Deep Submicron CMOS: Process Window Versus Complexity," 47 *IEEE Transactions on Electron Devices* 1484 (2000).
- Badenes et al., *A High Performance 0.18 um CMOS Technology Designed for Manufacturability*, 1997 *Proc. 27th European Solid-State Device Res. Conf.* 404.
- Badenes et al., Optimization of Critical Parameters in a Low Cost, High Performance Deep Submicron CMOS Technology, 1999 *Proc. 29th European Solid-State Device Res. Conf.* 628.
- Borland, *Novel Device Structures by Selective Epitaxial Growth (SEG)*, 1987 *Int'l Electron Devices Meeting Tech. Dig.* 12.
- Borland et al., Low Temperature Low Pressure Silicon Epitaxial Growth and Its Application to Advanced Dielectric Isolation Technology, 1986 *Extended Abstracts 18th Int'l Conf. on Solid State Devices and Materials* 53 (1986).
- Carns et al., Hole Mobility Measurements in Heavily Doped Si_{1-x}Ge_x Strained Layers, 41 *IEEE Transactions on Electron Devices* 1273 (1994).
- C. Carter et al., Residual Defects Following Rapid Thermal Annealing of Shallow Boron and Boron Fluoride Implants into Preamorphized Silicon, 44 *Applied Physics Letters* 459 (1984).
- Chau et al., "Advanced CMOS Transistors in the Nanotechnology Era for High-Performance, Low-Power Logic Applications," pp. 26-30 (2004).
- Cowern et al., *Diffusion in Strained Si(Ge)*, 72 *Physical Review Letters* 2585 (1994).
- Cressler, SiGe HBT Technology: A New Contender for Si-Based RF and Microwave Circuit Applications, 46 *IEEE Transactions on Microwave Theory and Tech.* 572 (1998).
- Daembkes et al., *The n-Channel SiGe/Si Modulation-Doped Field-Effect Transistor*, 33 *IEEE Transactions on Electron Devices* 633 (1986).
- Eichinger et al., "Characterization of MBE Growth SiGe Superlattices with SIMS and RBS," *Proceedings of the First International Symposium on Silicon Molecular Beam Epitaxy*, 85(7):367-375 (1985).
- Endo et al., *Novel Device Isolation Technology with Selective Epitaxial Growth*, 1982 *Int'l Electron Devices Meeting Tech. Dig.* 241.
- Endo et al., *Scaled CMOS Technology Using SEG Isolation and Buried Well Process*, 33 *IEEE Transactions on Electron Devices* 1659 (1986).
- Fahey et al., *Point Defects and Dopant Diffusion in Silicon*, 61 *Reviews of Modern Physics* 289 (1989).
- Fair, Boron Diffusion in Silicon-Concentration and Orientation Dependence, Background Effects and Profile Estimation, 122 *J. Electrochemical Soc'y* 800 (1975).
- Fair, "Concentration Profiles of Diffused Dopants in Silicon," *in Impurity Doping Processes in Silicon*, Chapt. 7, pp. 318-442 (1981).
- Fair, "Quantified Conditions for Emitter-Misfit Dislocation Formation in Silicon," *J. of the Electrochemical Soc'y*, 125(6):923-926 (1978).
- Fathy et al., "Formation of epitaxial layers of Ge on Si substrates by Ge implantation and oxidation," *Applied Physics Letters*, 51(17):1337-1339 (1987).
- Fitch, Selectivity Mechanisms in Low Pressure Selective Epitaxial Silicon Growth, 141 *J. Electrochemical Soc'y* 1046 (1994).
- Fuller et al., Diffusion of Donor and Acceptor Elements in Silicon, 27 *J. Applied Physics* 544 (1956).
- Gaworzewski et al., Electrical Properties of Lightly Doped p-Type Silicon-Germanium Single Crystals, 83 *J. Applied Physics* 5258 (1998).
- Ghani et al., "Effect of oxygen on minority-carrier lifetime and recombination currents in Si_{1-x}Ge_x heterostructure devices," *Applied Physics Letters*, 58(12):1317-1319 (1991).
- Gibbons et al., "Limited reaction processing: Silicon epitaxy," *Applied Physics Letters*, 47(7):721-723 (1985).
- Godbey et al., "A Si_{0.7}Ge_{0.3} Strained Layer Etch Stop for the Generation of Bond and Etch Back SOI," *SOS/SOI Tech. Conf. Proc.*, pp. 143-144 (1989).
- Goo et al., *Scalability of Strained-Si nMOSFETs Down to 25 nm Gate Length*, 24 *IEEE Electron Device Letters* 351 (2003).

- Gronet et al., "Growth of GeSi/Si strained-layer superlattices using limited reaction processing," 61 *J. Applied Physics* 6, pp. 2407-2409 (1987).
- Gwoziecki et al., *Suitability of Elevated Source/Drain for Deep Submicron CMOS*, 1999 Proc. 29th European Solid-State Device Res. Conf. 384.
- Haramé et al., *A High Performance Epitaxial SiGe-Base ECL BiCMOS Technology*, 1992 Int'l Electron Devices Meeting Tech. Dig. 19.
- Hobart et al., "Ultra-cut: A Simple Technique for the Fabrication of SOI Substrates with Ultra-Thin (<5 nm) Silicon Films," Proceedings 1998 IEEE International SOI Conference, pp. 145-146 (1998).
- Holländer et al., "Reduction of Dislocation Density of MBE-Grown Si_{1-x}Ge_x Layers on (100) Si by Rapid Thermal Annealing," *Thin Solid Films*, 183:157-164 (1989).
- Hopkins et al., *Enhanced Diffusion in Boron Implanted Silicon*, 132 *Journal of the Electrochemical Society* 2035 (1985).
- Hu et al., "Channel and Source/Drain Engineering in High-Performance Sub-0.1 um NMOSFETs Using X-Ray Lithography," 1994 *Symp. On VLSI Technology, Digest of Technical Papers* 17.
- Huang et al., "SiGe-on-insulator prepared by wafer bonding and layer transfer for high-performance field-effect transistors," *Applied Physics Letters*, 78(9):1267-1269 (2001).
- Huang et al., N-Channel MOS Transistors Below 0.5 um with Ultra-Shallow Channels Formed by Low Temperature Selective Silicon Epitaxy, 387 *Materials Res. Soc'y Symp. Proc.* 347 (1995).
- Hull et al., "Structural Studies of GeSi/Si Heterostructures," Proceedings of the First International Symposium on Silicon Molecular Beam Epitaxy, 85(7):376-384 (1985).
- Intel's Responses and Objections to AmberWave's Second Set of Interrogatories, U.S.D.C., District of Delaware, C.A. No. 05-301-KAJ, Feb. 3, 2006.
- Intel's Responses and Objections to AmberWave's Second Set of Requests for Production, U.S.D.C., District of Delaware, C.A. No. 05-301-KAJ, Feb. 3, 2006.
- Intel's Amended and Supplemented Responses and Objections to AmberWave's Second Set of Interrogatories, U.S.D.C., District of Delaware, C.A. No. 05-301-KAJ, Aug. 7, 2006.
- International Search Report for Int'l Application No. PCT/US01/46322, mailed Jan. 22, 2003 (4 pages).
- International Search Report for International Patent Application No. PCT/US02/03688, dated May 7, 2002 (4 pages).
- International Search Report for International Patent Application No. PCT/US03/19528, dated Sep. 16, 2003 (4 pages).
- Ishitani et al., "Local Loading Effect in Selective Silicon Epitaxy," 23 *Japanese Journal of Applied Physics* L391 (1984).
- Ismail et al., "Extremely high electron mobility in Si/SiGe modulation-doped heterostructures," *Applied Physics Letters*, 66(9):1077-1079 (1995).
- Ismail et al., "Gated Hall effect measurements in high-mobility n-type Si/SiGe modulation-doped heterostructures," *Applied Physics Letters*, 66(7):842-844 (1995).
- Ismail et al., "Identification of a Mobility-Limiting Scattering Mechanism in Modulation-Doped Si/SiGe Heterostructures," *Physical Review Letters*, 73(25):3447-3452 (1994).
- Jain et al., Theoretical Calculations of the Fermi Level and of Other Parameters in Phosphorus Doped Silicon at Diffusion Temperatures, 21 *IEEE Transactions on Electron Devices* 155 (1974).
- Kato, The Annealing Time and Temperature Dependence of Electrical Dopant Activation in High-Dose BF₂ Ion Implanted Silicon, 141 *Journal of the Electrochemical Society* 3158 (1994).
- Kasper, "Growth and Properties of Si/SiGe Superlattices," *Surface Science*, 174:630-639 (1986).
- Kim et al., Properties of c-Axis-Oriented Freestanding GaN Substrates Prepared on Fused Silica Glass by Hydride Vapor Phase Epitaxy, 33 *Journal of the Korean Physical Society* L1 (1998).
- King et al., Si/Si_{1-x}Ge_x Heterojunction Bipolar Transistors Produced by Limited Reaction Processing, 10 *IEEE Electron Device Letters* 52 (1989).
- Kitajima et al., *Crystalline Defects in Selectively Epitaxial Silicon Layers*, 22 *Japanese Journal of Applied Physics* L783 (1983).
- Ku et al., "High Performance pMOSFETs with Ni(SixGe1-x)/Poly-Si0.8Ge0.2 Gate," 2000 Symposium on VLSI Technology, Dig. of Tech. Papers, pp. 114-115.
- Kubota, M. et al., "New SOI CMOS Process with Selective Oxidation," 1986 IEEE IEDM Tech. Dig. pp. 814-816.
- Kuo, et al., Effects of Strain on Boron Diffusion in Si and Si_{1-x}Ge_x, 66 *Applied Physics Letters* 580 (1995).
- Lee et al., *High Quality Thin Epitaxial Silicon Layers Deposited Selectively by Rapid Thermal Processing*, 1989 Proc. Second Int'l Symp' on Ultra Large Scale Integration Sci. Tech. 233.
- Loechelt et al., "Measurement and Modeling of Boron Diffusion in Si and Strained Si_{1-x}Ge_x Epitaxial Layers During Rapid Thermal Annealing," 74 *J. Applied Physics* 5520 (1993).
- Lunnon et al., "Furnace and Rapid Thermal Annealing of P⁺/n Junctions in BF₂⁺-Implanted Silicon," 132 *Journal of the Electrochemical Society* 2473 (1985).
- Maleville et al., "Physical Phenomena Involved Involved in the Smart-Cut® Process," *Electrochemical Society Proceedings*, 96(3):34-46 (1996).
- Maseeh et al., *Plastic Deformation of Highly Doped Silicon*, A21-A23 *Sensors & Actuators* 861 (1990).
- Mazuré Facet Engineered Elevated Source/Drain by Selective Si Epitaxy for 0.35 Micron MOSFETS, 1992 *Int'l Electron Devices Meeting Tech. Dig.* 853.
- Mehregany et al., *Anisotropic Etching of Silicon in Hydrazine*, 13 *Sensors and Actuators* 375 (1988).
- Meyerson, "Low-Temperature Silicon Epitaxy by Ultrahigh Vacuum/Chemical Vapor Deposition," 48 *Applied Physics Letters* 797 (1986).
- Mieno et al., "Selective Doped Polysilicon Growth," *Journal of the Electrochemical Society* 11, 2862-2867 (1987).
- Z.H. Ming et al., "Microscopic Structure of Interfaces in Si_{1-x}Ge_x/Si Heterostructures and Superlattices Studied by X-ray Scattering and Fluorescence Yield," 47 *Physical Review B*, No. 24, pp. 373-381 (1993).
- Z.H. Ming et al., "Interfacial Roughness Scaling and Strain in Lattice Mismatched Si_{0.4}Ge_{0.6} Thin Films on Si," 67 *Applied Physics Letters* 5, pp. 629-631 (1995).
- Mirabedini et al., Submicrometre Elevated Source and Drain MOSFET Technology Using E-Beam Evaporated Silicon, 33 *Electronics Letters* 1183 (1997).
- Mistry et al., "Delaying Forever: Uniaxial Strained Silicon Transistors in a 90nm CMOS Technology," Symposium on VLSI Technology Digest of of Technical Papers, pp. 50-51 (2004).
- Miyauchi et al., "Low-Temperature (850° C.) Silicon Selective Epitaxial Growth on HF-Treated Si (100) Substrates Using SiH₄-HCl-H₂ Systems," 138 *Journal of the Electrochemical Society* 3480 (1991).
- Mizuo et al., "Anomalous Diffusion of B and P in Si Directly Masked with Si₃N₄," *Japanese Journal of Applied Physics* 281 (1982).
- Monroe et al., "Comparison of mobility-limiting mechanisms in high-mobility Si_{1-x}Ge_x heterostructures," *Journal of Vac. Sci. Technol. B*, 11(4):1731-1737 (1993).
- Moriya et al., "Boron Diffusion in Strained Si_{1-x}Ge_x Epitaxial Layers," 71 *Physical Review Letters* 883 (1993).
- Moriya et al., "Doping and Electrical Characteristics of In Situ Heavily B-Doped Si_{1-x}Ge_x Films Epitaxially Grown Using Ultraclean LPCVD," 343-344 *Thin Solid Films* 541 (1999).
- Moslehi et al., *Single-Wafer Integrated Semiconductor Device Processing*, 39 *IEEE Transactions on Electron Devices* 4 (1992).
- Murota et al., "CVD Si_{1-x}Ge_x Epitaxial Growth and Its Doping Control," 27 *Journal of the Japanese Ass'n for Crystal Growth* 171 (2000).
- Nakahara et al., Ultra-Shallow In-Situ-Doped Raised Source/Drain Structure for Sub-Tenth Micron CMOS, 1996 *Symp. on VLSI Tech., Dig. Tech. Papers* 174.
- Nishi et al., "Handbook of Semiconductor Manufacturing Technology," Marcel Dekker AG, New York, NY, pp. 1-22 (2000).
- Noble et al., "Reduction in misfit dislocation density by the selective growth of Si_{1-x}Ge_x/Si in small areas," *Applied Physics Letters*, 56(1):51-53 (1990).

- Noda et al., "Doping and Electrical Characteristics of In-Situ Heavily B-Doped $\text{Si}_{1-x-y}\text{Ge}_x\text{C}_y$ Films Epitaxially Grown Using Ultraclean LPCVD," 380 *Thin Solid Films* 57 (2000).
- Noh et al., "Contact Resistivity Between Tungsten and Impurity (P and B)-doped $\text{Si}_{1-x-y}\text{Ge}_x\text{C}_y$ Epitaxial Layer," *Applied Surface Sci.* 679 (2003).
- O'Neill et al., "Deep Submicron CMOS Based on Silicon Germanium Technology," 43 *IEEE Transactions on Electron Devices* 6, pp. 911-918 (1996).
- Park et al., Analysis of Ion-Implanted Amorphous and Polycrystalline Silicon Films as Diffusion Sources for Ultrashallow Junctions, 70 *J. Applied Physics* 1397 (1991).
- Patton et al., Silicon-Germanium-Base Heterojunction Bipolar Transistors by Molecular Beam Epitaxy, 9 *IEEE Electron Device Letters* 165 (1988).
- Pfiester et al., Anomalous Co-Diffusion Effects of Germanium on Group III and V Dopants in Silicon, 52 *Applied Physics Letters* 471 (1988).
- Powell, "Activation of Shallow, High-Dose BF_2^{30} Implants into Silicon by Rapid Thermal Processing," 56 *J. Applied Physics* 2837 (1984).
- Prinz et al., "The Effects of Base Dopant Outdiffusion and Undoped $\text{Si}_{1-x}\text{Ge}_x$ Junction Spacer Layers in $\text{Si}/\text{Si}_{1-x}\text{Ge}_x/\text{Si}$ Heterojunction Bipolar Transistors," 12 *IEEE Electron Device Letters* 42 (1991).
- Prinz et al., "The Effect of Base-Emitter Spacers and Strain Dependent Densities of States in $\text{Si}/\text{Si}_{1-x}\text{Ge}_x/\text{Si}$ Heterojunction Bipolar Transistors," 1989 *Int'l Electron Devices Meeting Tech. Dig.* 639.
- Rim et al., Characteristics and Device Design of Sub-100 nm Strained Si N- and PMOSFETs, 2002 *Symp. on VLSI Tech., Digest Tech. Papers* 98.
- Rim et al., Low Field Mobility Characteristics of Sub-100 nm Unstrained and Strained Si MOSFETs, 2002 *Int'l Electron Devices Meeting Tech. Dig.* 43.
- Rim et al., *Strained Si NMOSFETs for High Performance CMOS Technology*, 2001 *Symp. on VLSI Tech., Digest Tech. Papers* 59.
- Rodrigues et al., "Strain Compensation by Heavy Boron Doping in $\text{Si}_{1-x}\text{Ge}_x$ Layers Grown by Solid Phase Epitaxy," 12 *J. Materials Res.* 1698 (1997).
- Ryssel et al., High Concentration Effects of Ion Implanted Boron in Silicon, 22 *Applied Physics* 35 (1980).
- Schäffler, "Letter to the Editor, High-electron-mobility Si/SiGe heterostructures: influence of the relaxed SiGe buffer layer," *Semicond. Sci. Technol.*, 7:260-266 (1992).
- Schumann et al., *Impact of Elevated Source/Drain on the Reverse Short Channel Effect*, 1999 Proc. 29th European Solid-State Device Res. Conf. 572.
- Shifren et al., "Drive current enhancement in p-type metal-oxide-semiconductor field-effect transistors under shear uniaxial stress," *Applied Physics Letters*, 85(25):6188-6190 (2004).
- Simard-Normandin, "Electrical Characteristics and Contact Resistance of B^+ - and BF_2^+ - Implanted Silicon Diodes with Furnace and Rapid Thermal Annealing," 32 *IEEE Transactions on Electron Devices* 1354 (1985).
- Solmi et al., High-Concentration Boron Diffusion in Silicon: Simulation of the Precipitation Phenomena, 68 *J. Applied Physics* 3250 (1990).
- Song et al., Facet Formation in Selectively Overgrown Silicon by Reduced Pressure Chemical Vapor Deposition, 1998 *Dig. Papers Microprocesses and Nanotechnology '98* 240.
- Stach et al., *Anomalous Boron Diffusion in Silicon from Planar Boron Nitride Sources*, 121 *Journal of the Electrochemical Society* 722 (1974).
- Stivers et al., *Growth Condition Dependence of SEG Planarity and Electrical Characteristics*, 1987 Proc. Tenth Int'l Conf. on Chemical Vapor Deposition 389.
- Subbanna et al., "How SiGe Evolved into a Manufacturable Semiconductor Production Process," *IEEE International Solid-State Circuits Conference*, pp. 56, 67, 446 (1999).
- N. Sugii et al., "Role of $\text{Si}(1-x)\text{Ge}(x)$ buffer layer on mobility enhancement in a strained-Si n-channel metal-oxide-semiconductor field-effect transistor," 75 *Applied Physics Letters* 19, pp. 2948-2950 (1999).
- Sugiyama et al., "Formation of strained-silicon layer on thin relaxed- $\text{SiGe}/\text{SiO}_2/\text{Si}$ structure using SIMOX technology," *Thin Solid Films*, 369:199-202 (2000).
- Sun et al., "Elevated n⁺/p Junctions by Implant into CoSi_2 Formed on Selective Epitaxy for Deep Submicron MOSFET's," 45 *IEEE Transactions on Electron Devices* 1946 (1998).
- Sun et al., Parasitic Resistance Considerations of Using Elevated Source/Drain Technology for Deep Submicron Metal Oxide Semiconductor Field Effect Transistors, 145 *Journal of the Electrochemical Society* 2131 (1998).
- Taraschi et al., "Relaxed SiGe -on-insulator fabricated via wafer bonding and etch back," *Journal of Vac. Sci. Technol. B*, 20(2):725-727 (2002).
- Taraschi et al., "Strained-Si-on-Insulator (SSOI) and SiGe -on-Insulator (SGOI): Fabrication Obstacles and Solutions," *Mat. Res. Soc. Symp. Proc.*, 745:105-110 (2003).
- Taraschi et al., "Relaxed SiGe on Insulator Fabricated via Wafer Bonding and Layer Transfer: Etch-Back and Smart-Cut Alternatives," *Electrochemical Society Proceedings*, 2001(3):27-32 (2001).
- van Dort et al., Influence of High Substrate Doping Levels on the Threshold Voltage and the Mobility of Deep-Submicrometer MOSFET's, 39 *IEEE Transactions on Electron Devices* 932 (1992).
- van Meer et al., High Performance Raised Gate/Source/Drain Transistors for Sub-0.15 μm CMOS Technologies, 1999 Proc. 29th European Solid-State Device Res. Conf. 388.
- van Oostrum et al., Characterization of Epitaxial Layers by the Depth Dependence of Boron Diffusivity, 61 *Applied Physics Letters* 1513 (1992).
- Vossen et al., *Thin Films Processes II*, Academic Press, San Diego, CA, pp. 370-442 (1991).
- Waite et al., *A Novel Deep Submicron Elevated Source/Drain MOSFET*, pp. 148-151.
- Walker et al., Shallow Boron Junctions and Preamorphization for Deep Submicron Silicon Technology, 73 *J. Applied Physics* 4048 (1993).
- Wang, Identification and Measurement of Scaling-Dependent Parasitic Capacitances of Small-Geometry MOSFET's, 43 *IEEE Transactions on Electron Devices* 965 (1996).
- Weldon et al., Raised Source-Drains Using Selective Silicon Deposition for Sub-Half Micron CMOS Devices, 94-2 *Extended Abstracts Fall Meeting Electrochemical Soc'y* 756 (1994).
- Wolfe et al., "Silicon Processing for the VLSI ERA, vol. 1; Process Technology," Marcel Dekker AG, New York, NY, pp. 1-22 (2000).
- Wong, *Beyond the Conventional Transistor*, 46 *IBM J. Res. & Dev.* 133 (2002).
- Yamakawa et al., Drivability Improvement on Deep-Submicron MOSFET's by Elevation of Source/Drain Regions, 20 *IEEE Electron Device Letters* 366 (1999).
- Examination Report for European Patent Application No. 01 973 651.1, dated Sep. 7, 2005 (4 pages).
- Czaja, "Conditions for the Generation of Slip by Diffusion of Phosphorus into Silicon, 37 *J. App. Physics* 3441" (1966).
- Miyake et al., "Transient Enhanced Diffusion of Ion-Implanted Boron in Si During Rapid Thermal Annealing," 63 *J. App. Physics* 1754 (1988).
- Soderbarg, "Fabrication of BESOI-Materials Using Implanted Nitrogen as an Effective Etch Stop Barrier," 1989 *IEEE SOS/SOI Technology Conference*, pp. 64.
- Suzuki et al., "Effects of Si-Ge Buffer Layer for Low-temperature Si Epitaxial Growth on Si Substrate by RF Plasma Chemical Vapor Deposition," 54 *J. App. Physics* 1466 (1983).
- Tanno et al., "Selective Silicon Epitaxy Using Reduced Pressure Technique," 21 *Japanese J. App. Physics* L564 (1982).
- Tsai et al., "Recrystallization of Implanted Amorphous Silicon Layers. I. Electrical Properties of Silicon Implanted with BF_2^+ or $\text{Si}^+ + \text{B}^{+a}$," 50 *J. App. Physics* 183 (1979).
- Yeo et al., "Nanoscale Ultra-Thin-Body Silicon-on-Insulator P-MOSFET with a SiGe/Si Heterostructure Channel," 21 *IEEE Device Letters* 4, pp. 161-163 (2000).

Aoki et al., "Optimum Crystallographic Orientation of Submicron CMOS Devices," 1985 IEDM 577-580.

Bowling, "Single-Wafer Processing and Real-Time Process Control for Semiconductor Integrated Circuit Manufacturing," 1994 Int'l Symp. on Semiconductor Manufacturing, pp. 31-33.

Chau, "A 50 nm Depleted-Substrate CMOS Transistor (DST)," 2001 IEDM 621-624.

Request for *Ex Parte* Reexamination of U.S. Patent No. 7,122,449, Oct. 17, 2006.

Saddow et al., "Lateral Epitaxial Overgrowth and Pendeo Epitaxy of 3C-SiC on Si Substrates," 1999 Int'l Conf. on SiC and Related Materials.

Partial International Search Report for Internation Patent Application No. PCT/US2006/035814, Feb. 7, 2007 (7 pages).

Andrieu et al., "Co-integrated Dual Strained Channels on Fully Depleted sSDOI CMOSFETs with HfO₂/TiN Gate Stack down to 15 nm Gate Length," 2005 IEEE Int'l SOI Conf. Proc., pp. 223-224.

Al-Bayati et al., "Exploring the limits of pre-amorphization implants on controlling channeling and diffusion of low energy B implants and ultra shallow junction formation," 2000 Conf. on Ion Implantation Technology, pp. 54-57.

Thean et al., "Performance of super-critical strained-si directly on insulator (SC-SSOI) CMOS based on high-performance PD-SOI technology," 2005 Symp. on VLSI Tech., Dig. Tech. Papers, pp. 134-135.

AmberWave Systems Corporation's Responses to Intel's Second Set of Requests for Production, U.S.D.C., District of Delaware, C.A. No. 05-301-KAJ, (Feb. 3, 2006).

AmberWave Systems Corporation's Responses to Intel's Third Set of Interrogatories, U.S.D.C., District of Delaware, C.A. No. 05-301-KAJ (condolidated), (Feb. 3, 2006).

AmberWave Systems Corporation's First Supplemental Responses to Intel's Third Set of Interrogatories, U.S.D.C., District of Delaware, C.A. No. 05-301-KAJ (consolidated), (Mar. 27, 2006).

AmberWave Systems Corporation's Responses to Intel's Third Set of Requests for Production, U.S.D.C., District of Delaware, C.A. No. 05-301-KAJ (consolidated), (Feb. 10, 2006).

AmberWave Systems Corporation's Responses to Intel's Fourth Set of Interrogatories, U.S.D.C., District of Delaware, C.A. No. 05-301-KAJ (consolidated), (Feb. 27, 2006).

AmberWave Systems Corporation's Respoonses to Intel's Fifth Set of Requests for Production, U.S.D.C., District of Delaware, C.A. No. 05-301-KAJ (consolidated), (Jun. 30, 2006).

AmberWave Systems Corporation's Responses to Intel's Fifth Set of Interrogatories, U.S.D.C., District of Delaware, C.A. No. 05-301-KAJ (consolidated), (Jun. 19, 2006).

Intel's Responses and Objections to AmberWave's Fourth Set of Requests for Production, U.S.D.C., District of Delaware, C.A. No. 05-301-KAJ (consolidated), Aug. 17, 2006.

Ghandhi, "VLSI Fabrication Principles: Silicon and Gallium Arsenide," Chapter 6, pp. 368-450 (John Wiley & Sons, Inc. 1994).

Habermehl, 83 J. Applied Physics 9, p. 4672 (1998).

Lee et al., 147 J. Electrochemical Society 4, p. 1481 (2000).

Loboda et al., 11 J. Mater. Research 2, p. 391 (1996).

Muller et al., "Semiconductor Electronics," *in* Device Electronics for Integrated Circuits, 2nd ed., New York, NY, pp. 1-10 (Wiley & Sons 1977).

Sekimoto et al., 21 J. Vac. Sci. Technol. 4, pp. 1017 (1982).

Steege et al., "Silicide Induced Pattern Density & Orientation Dependent Transconductance in MOS Transistors," 1999 IEDM, pp. 497-500.

Wolf and Tauber, Silicon Processing for the VLSI Era vol 1: Process Technology, 2nd Ed., 2000, pp. 203, Table 6-3.

* cited by examiner

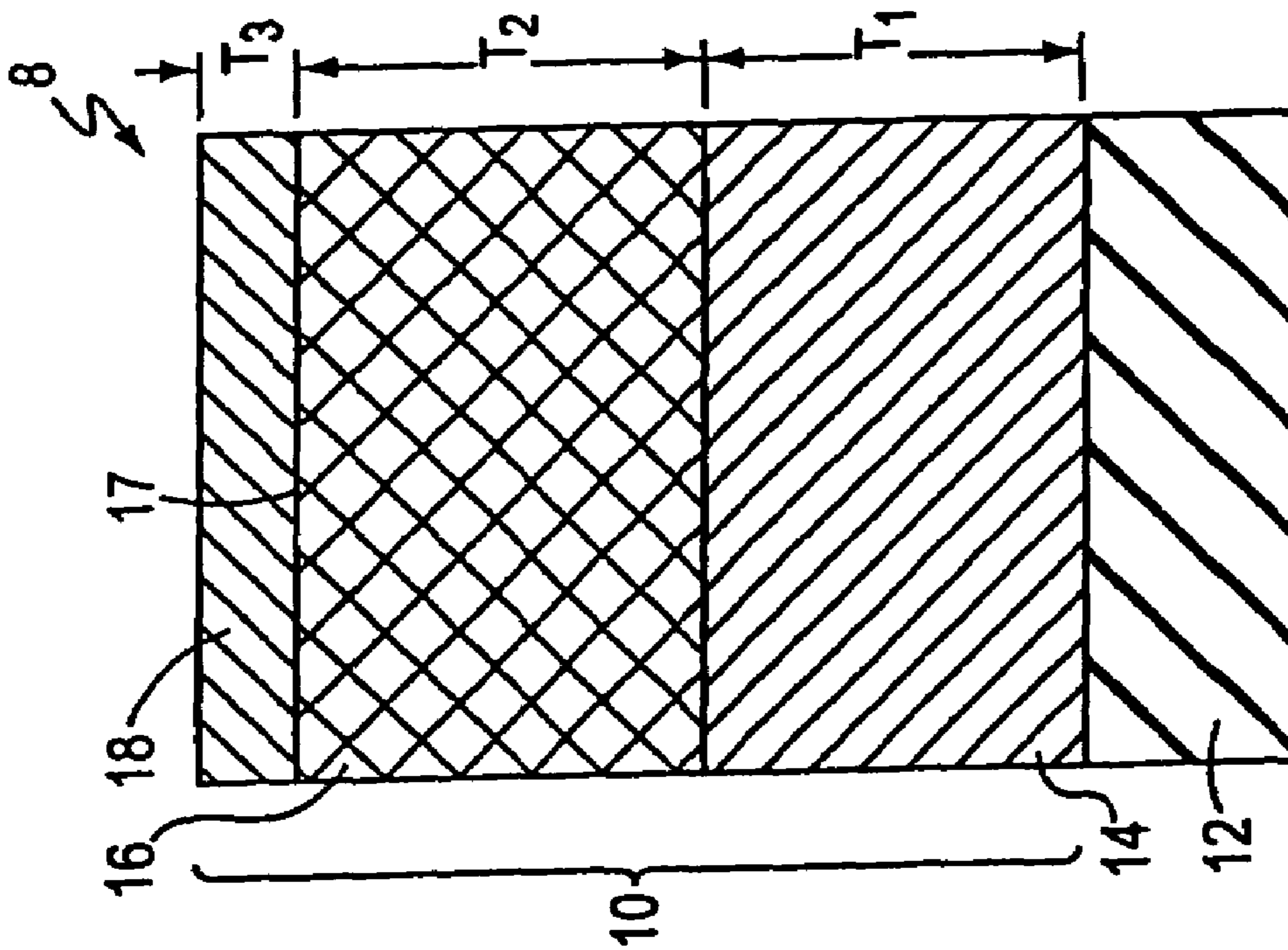

FIG. 1A

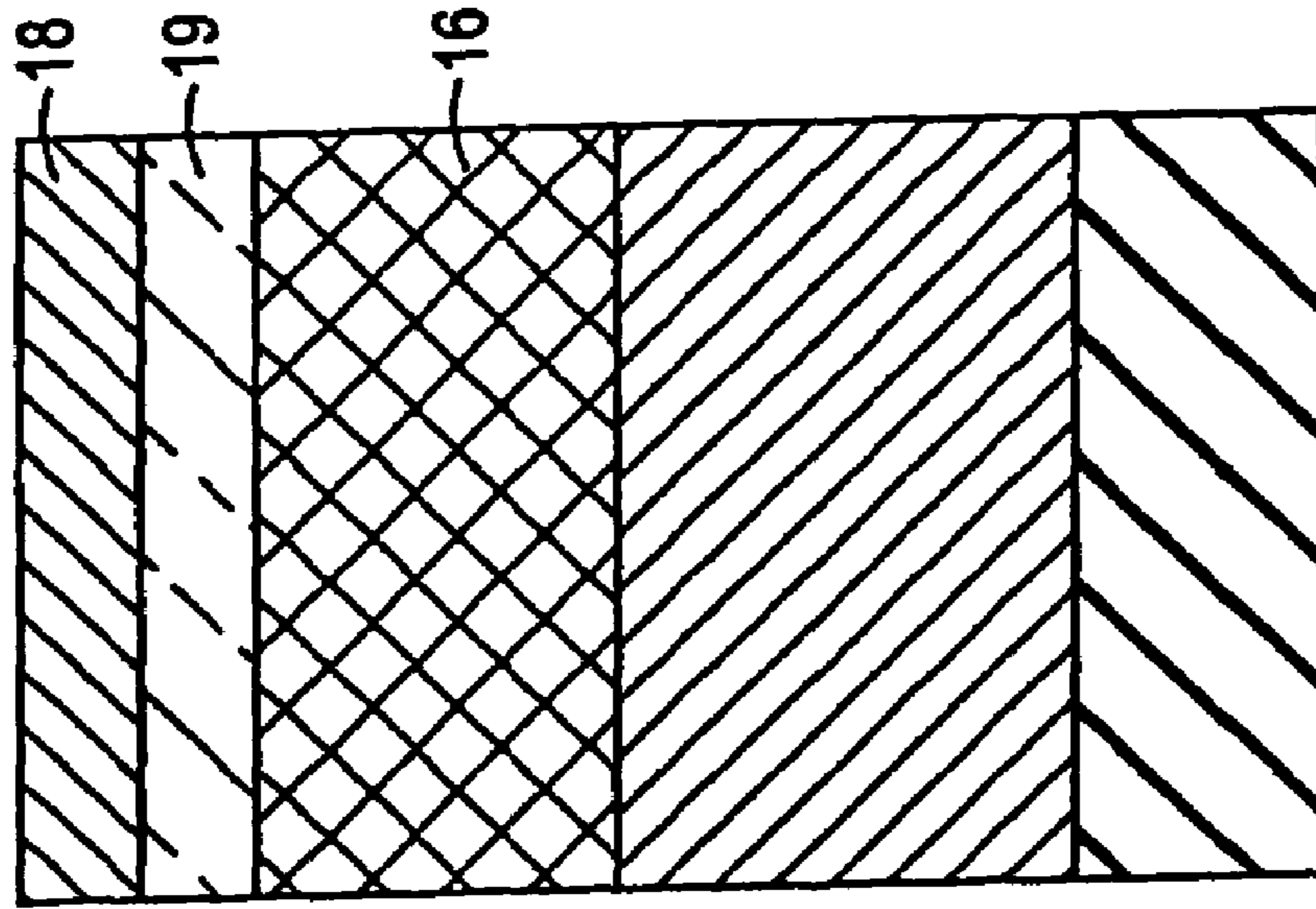

FIG. 1B

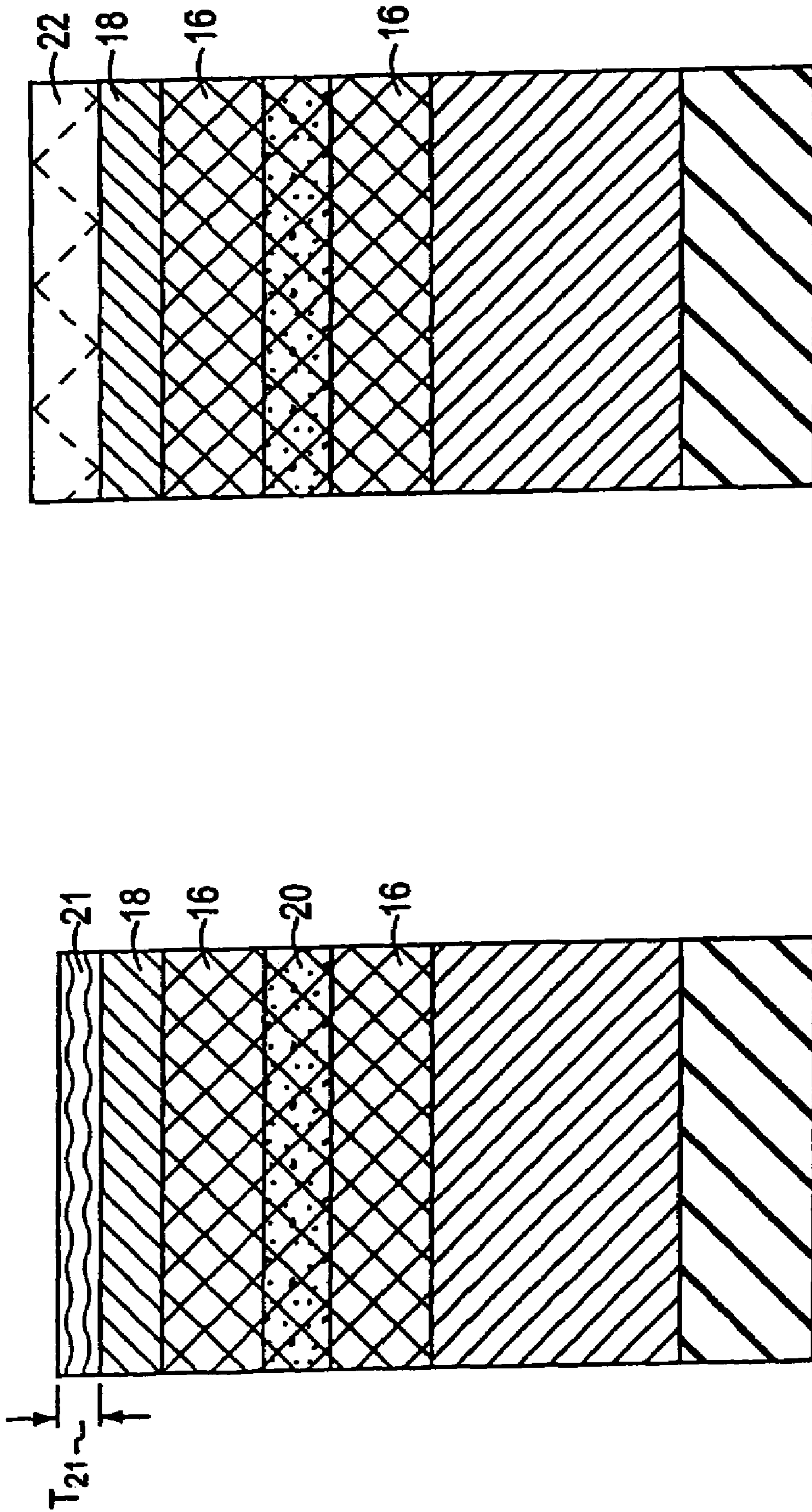

FIG. 2A

FIG. 2B

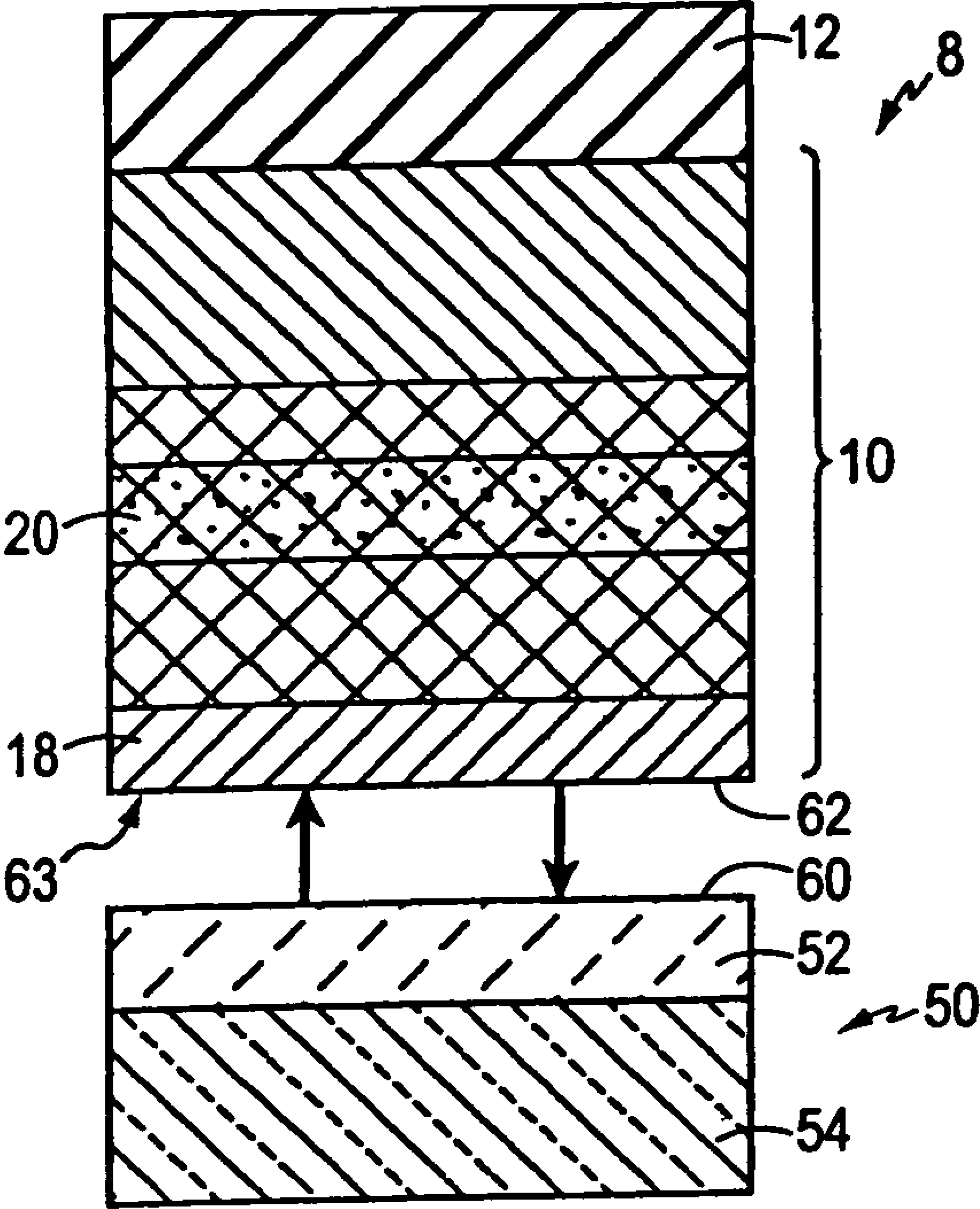

FIG. 3

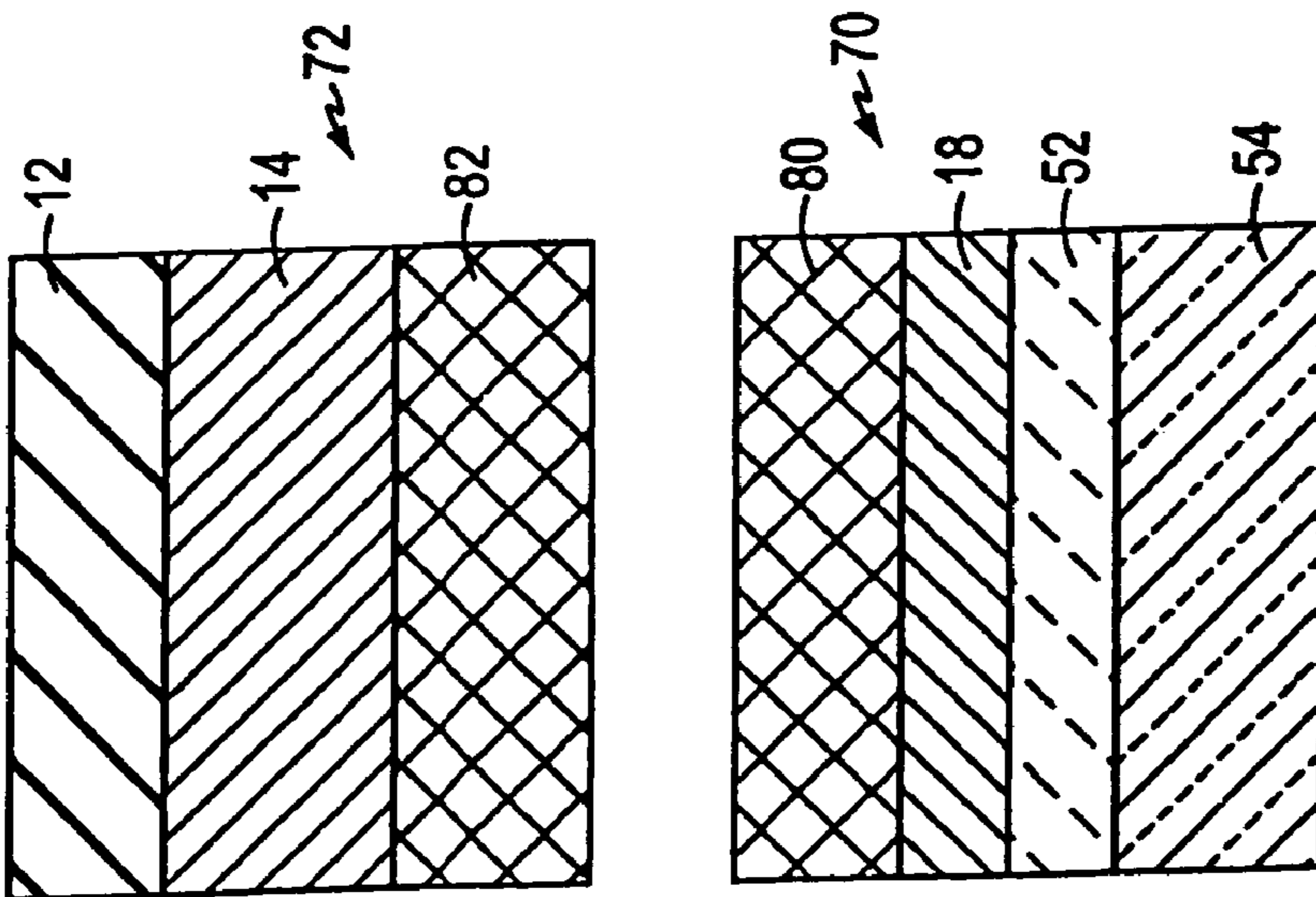

FIG. 4

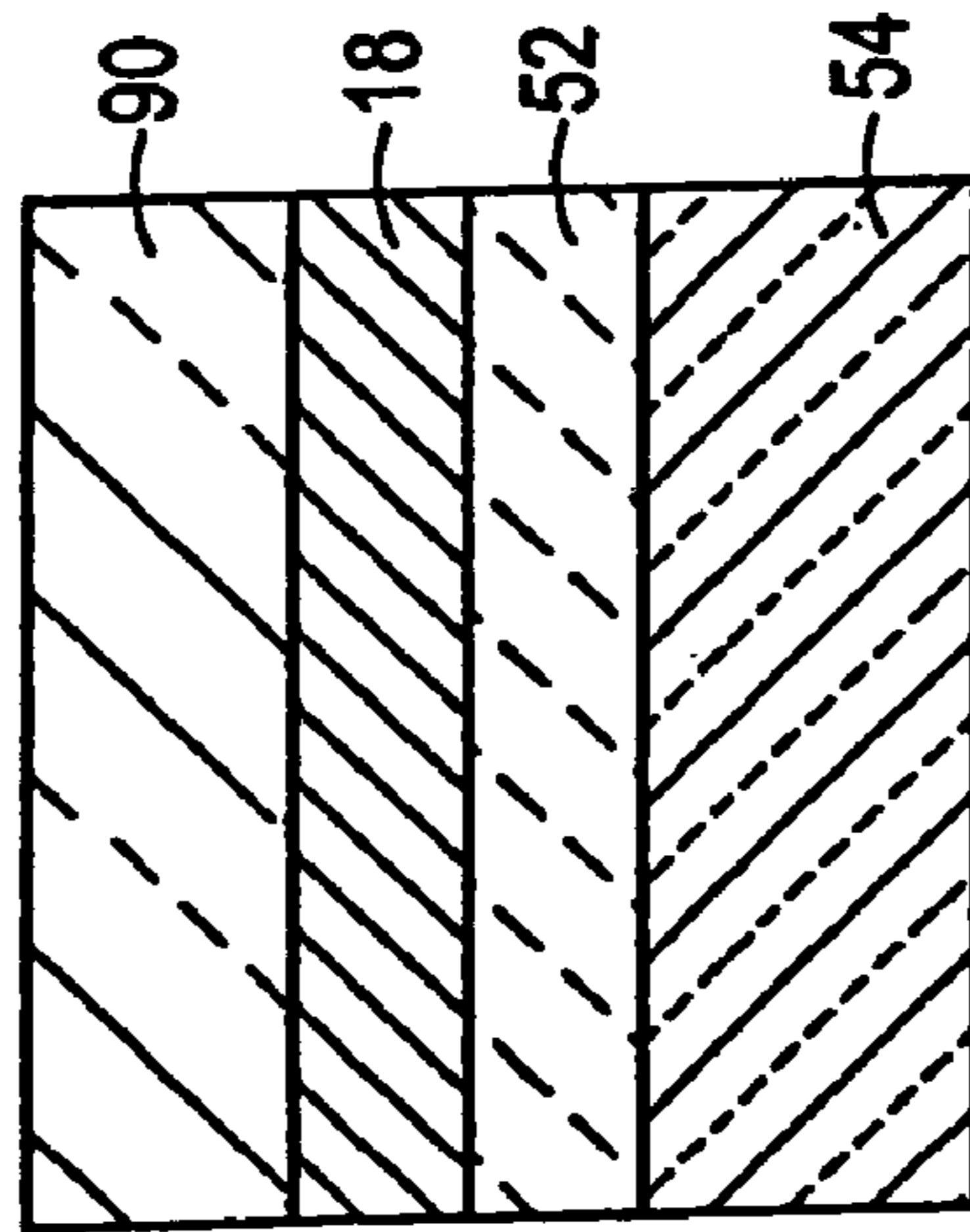

FIG. 5

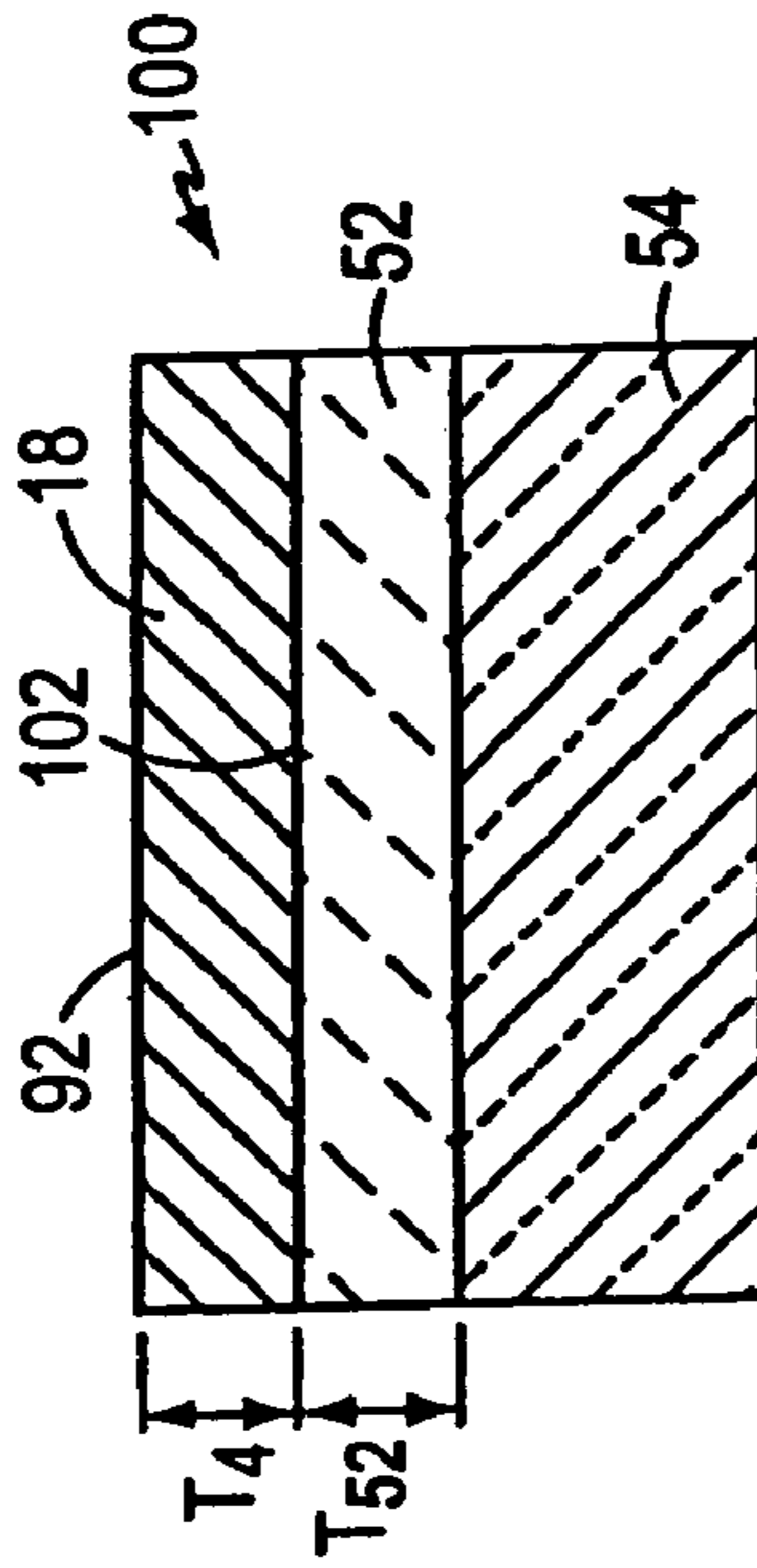

FIG. 6

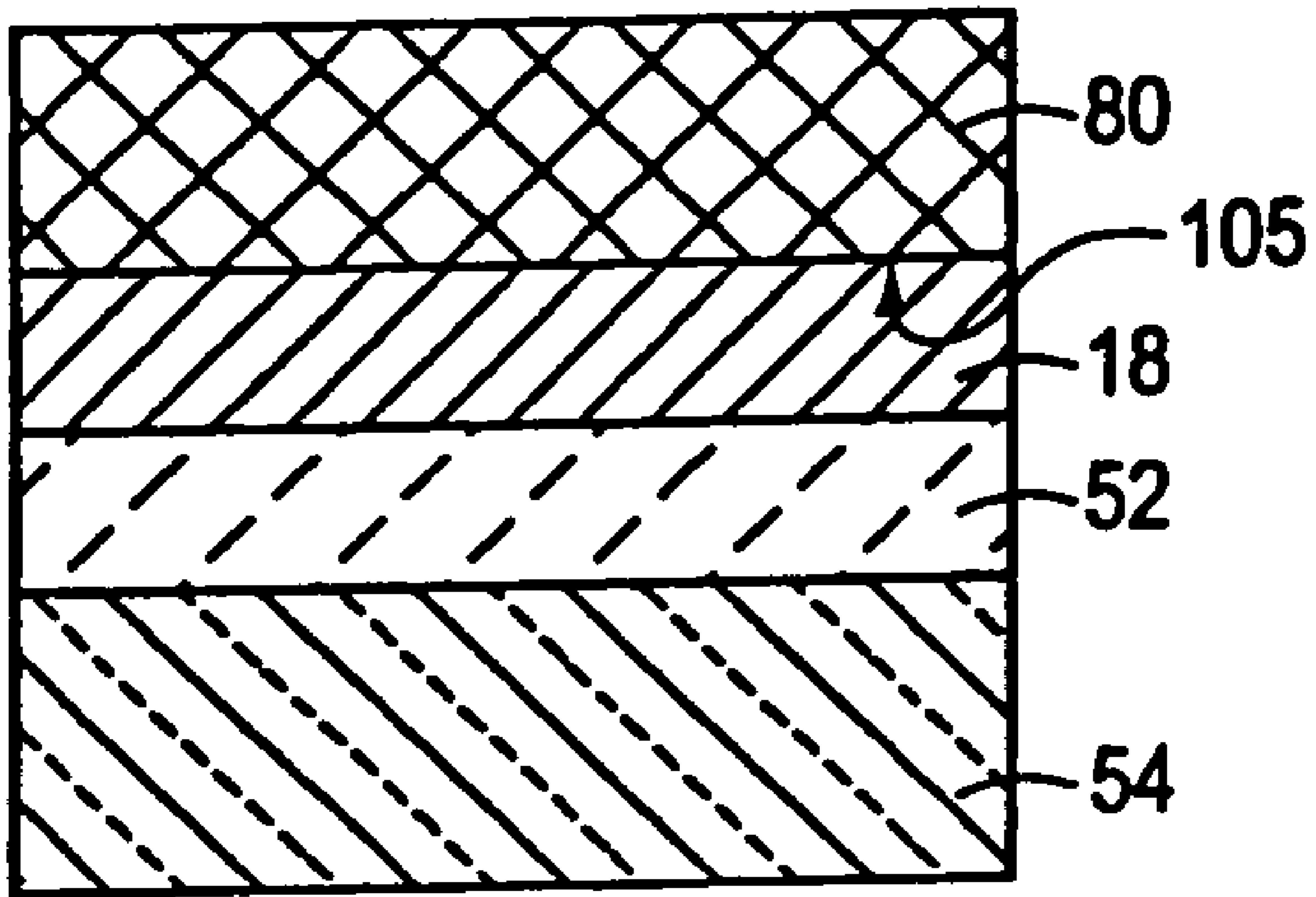

FIG. 7

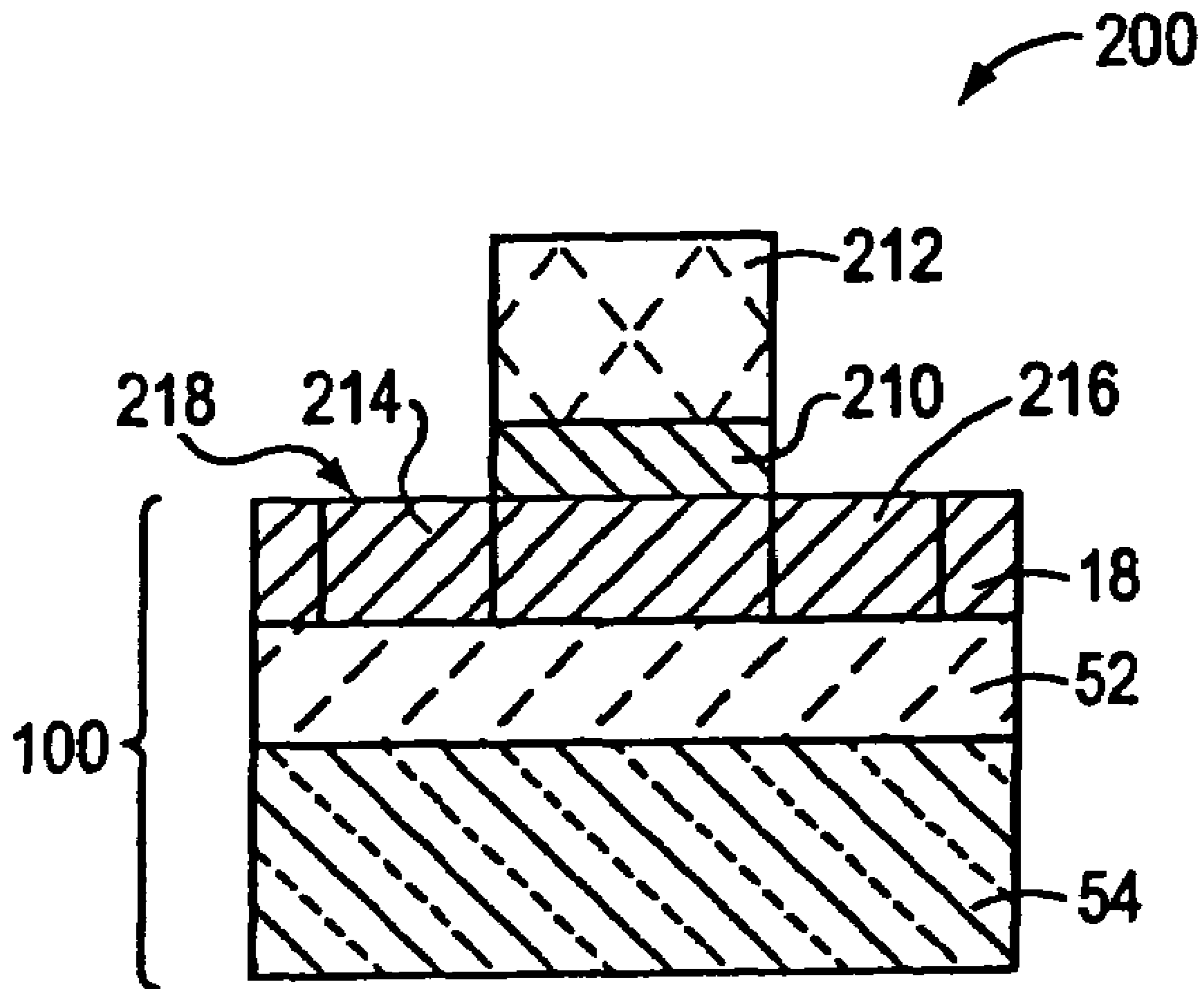

FIG. 8A

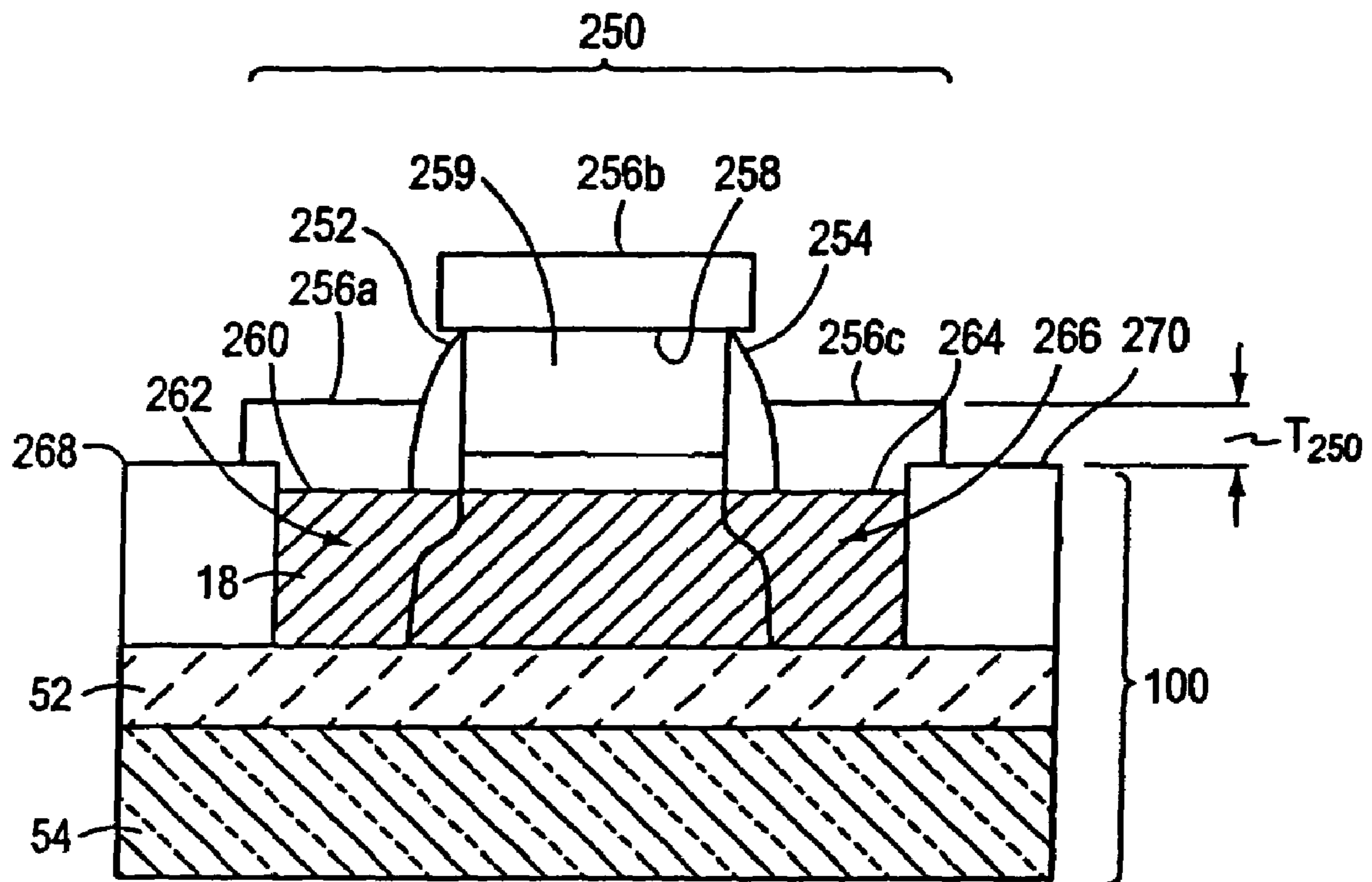

FIG. 8B

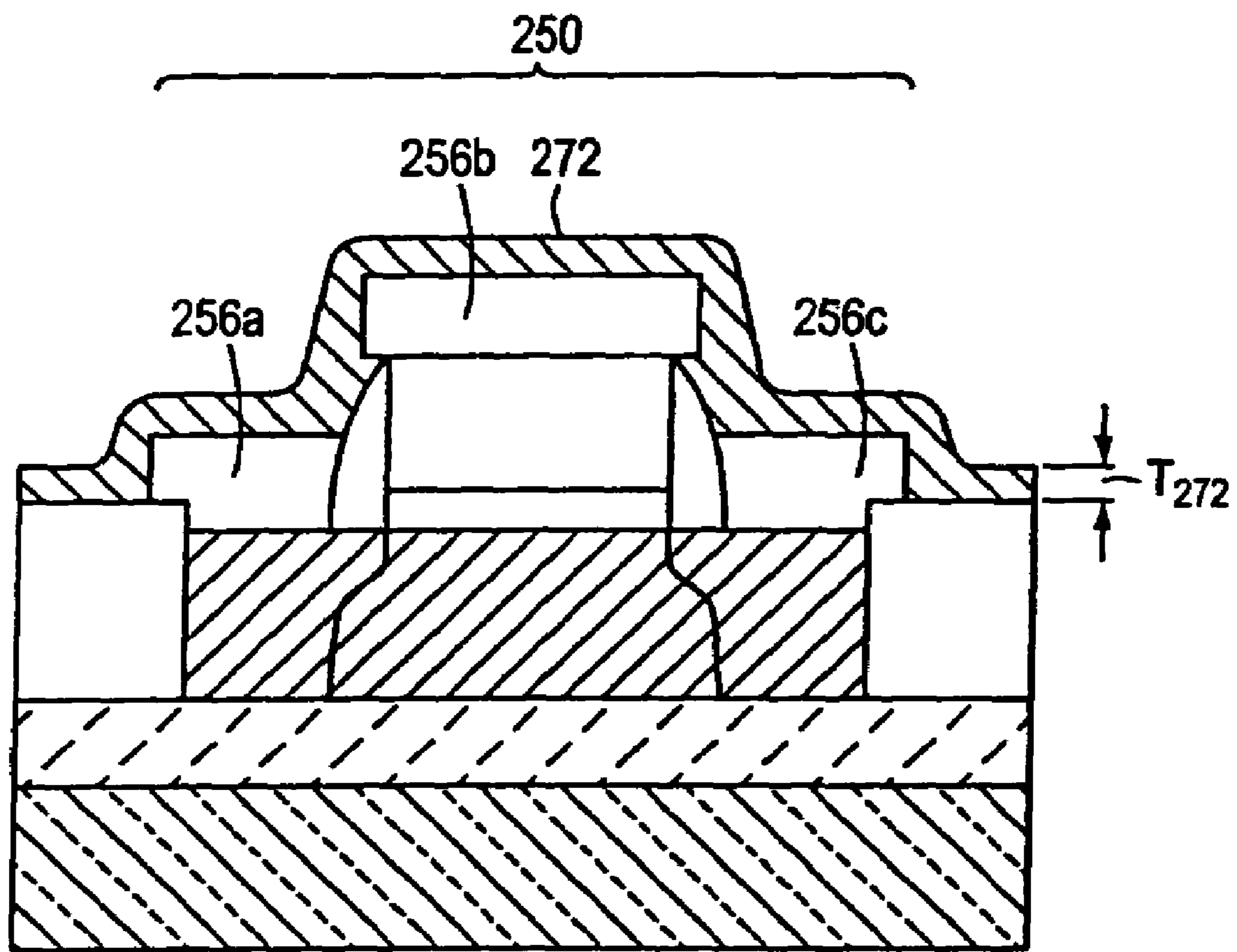

FIG. 8C

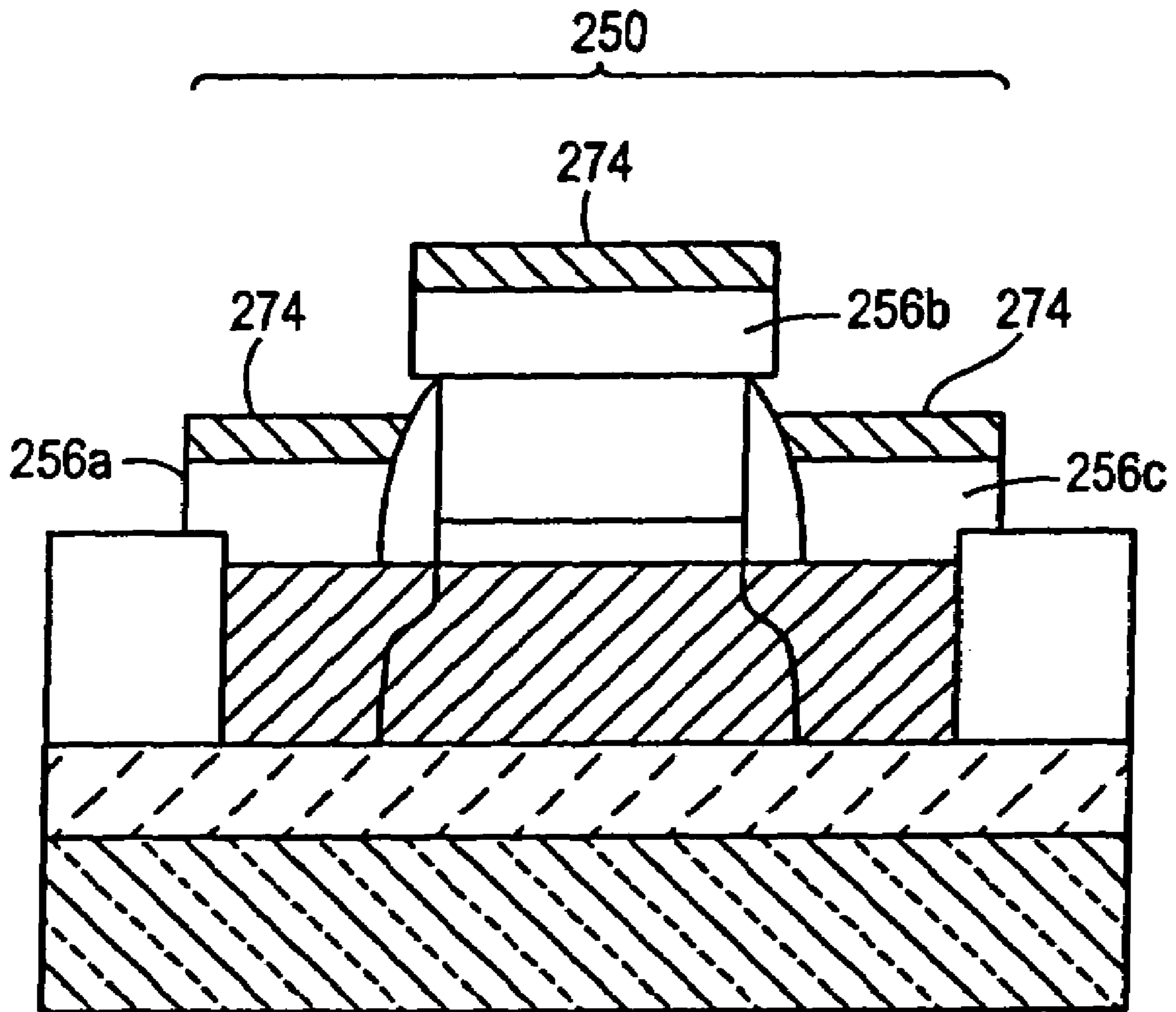

FIG. 8D

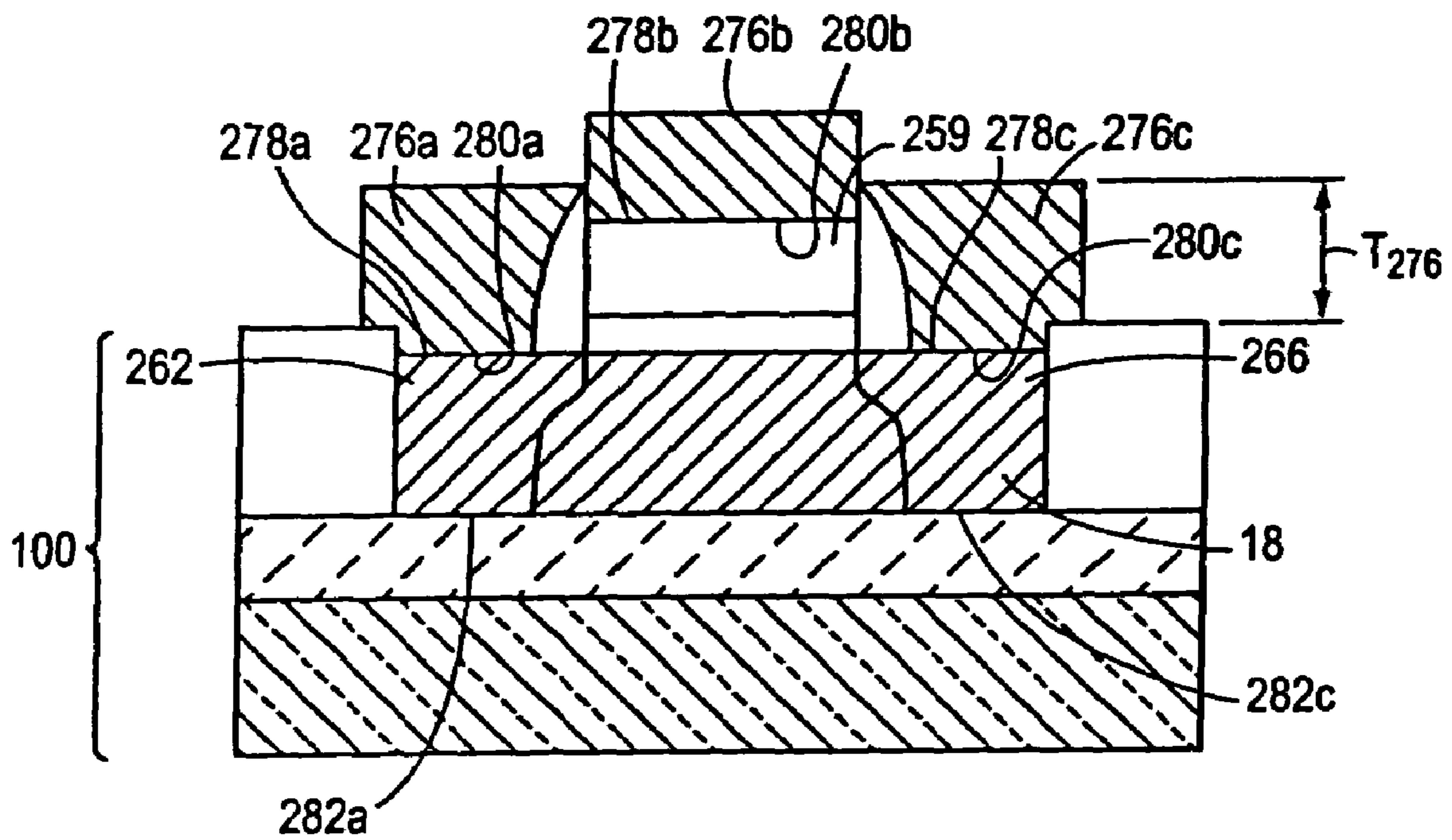

FIG. 8E

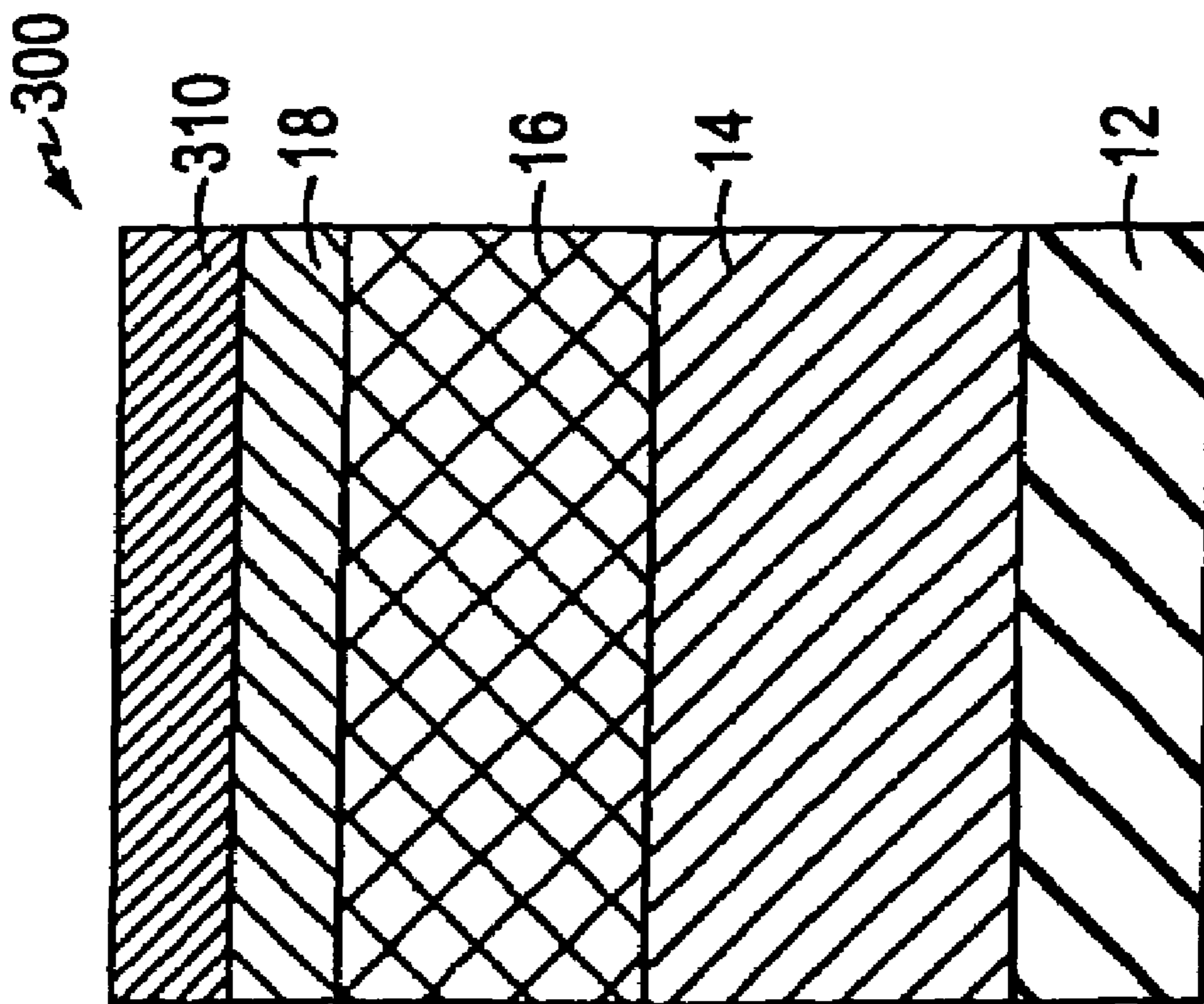

FIG. 9

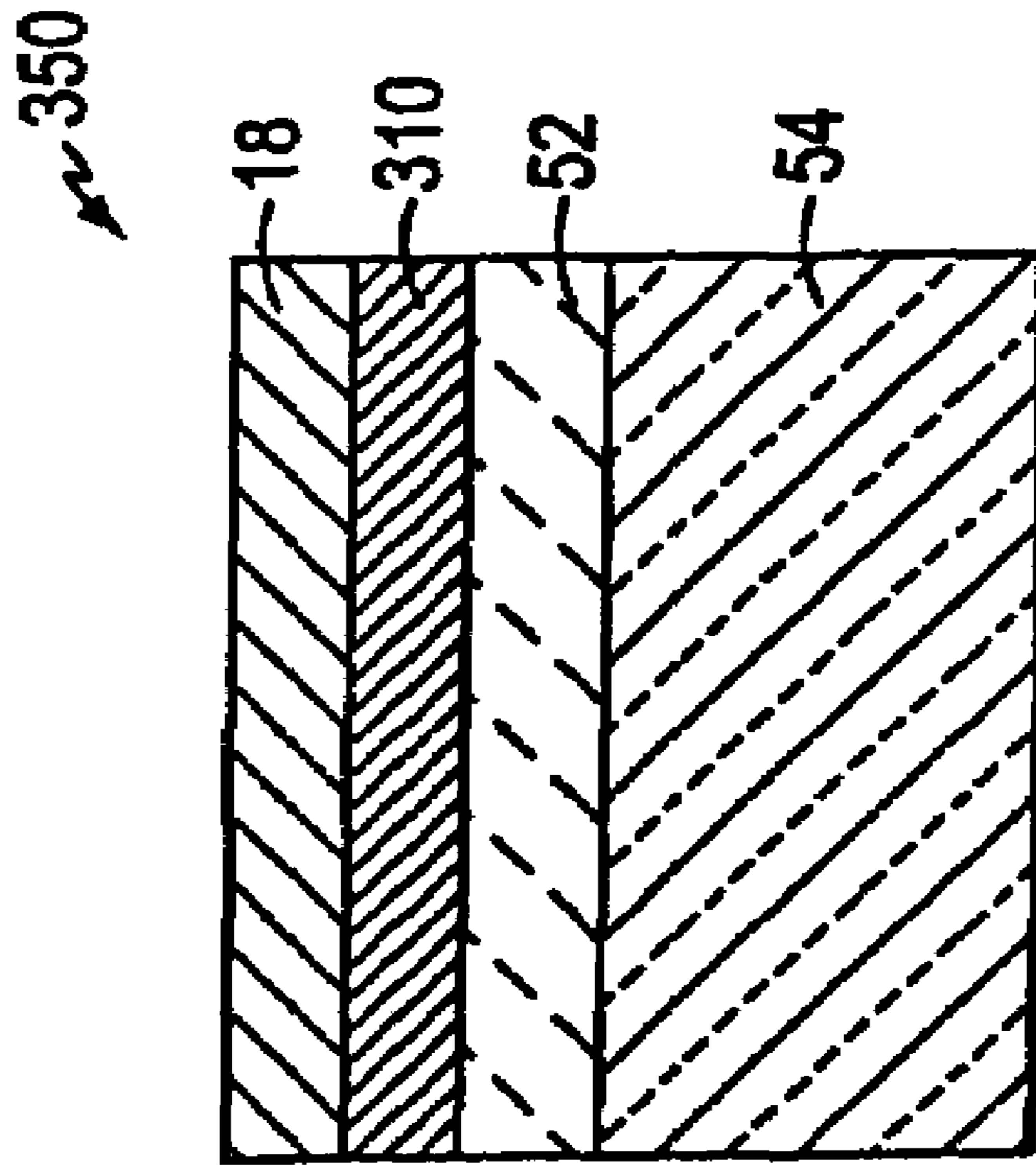

FIG. 10

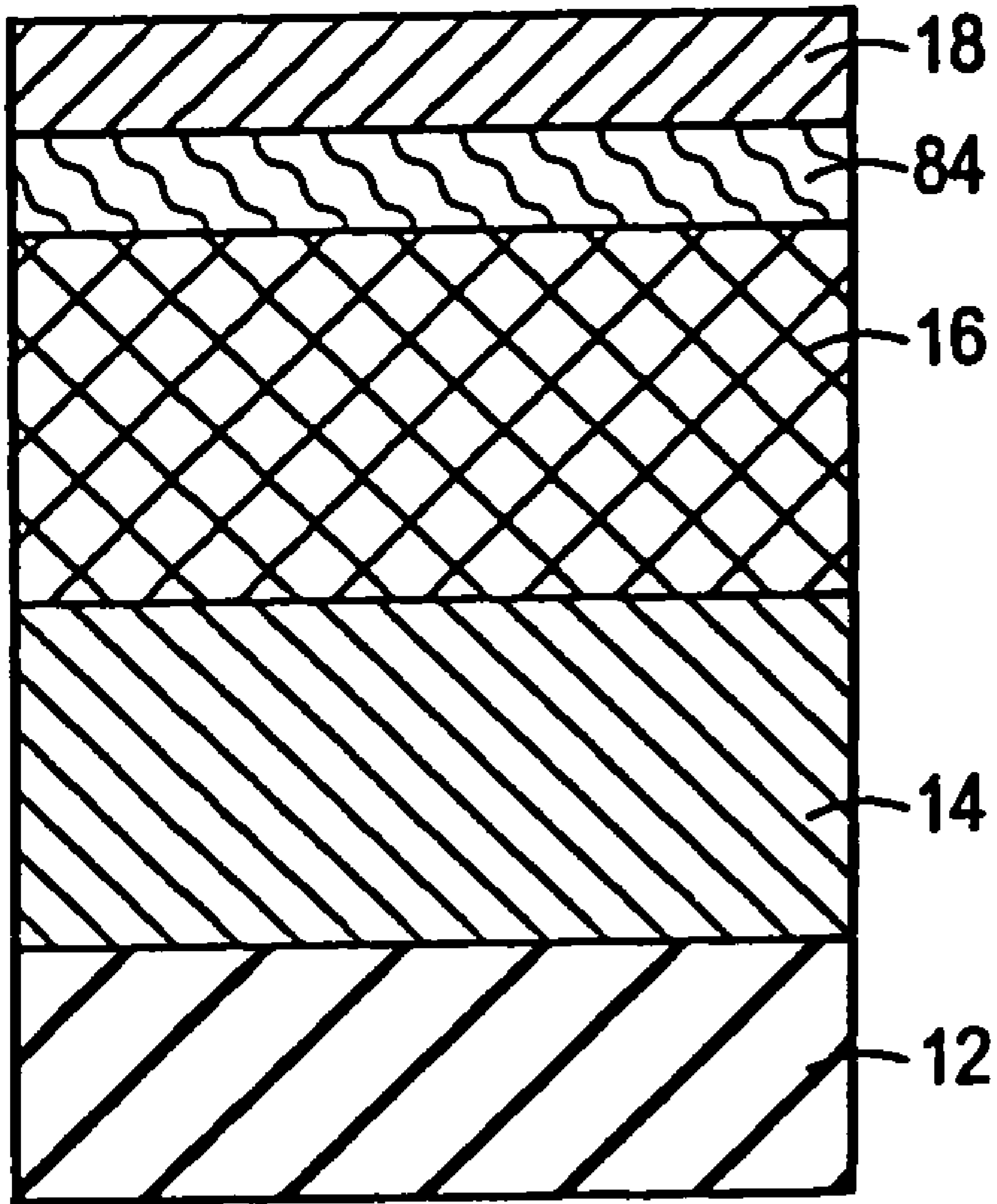

FIG. 11

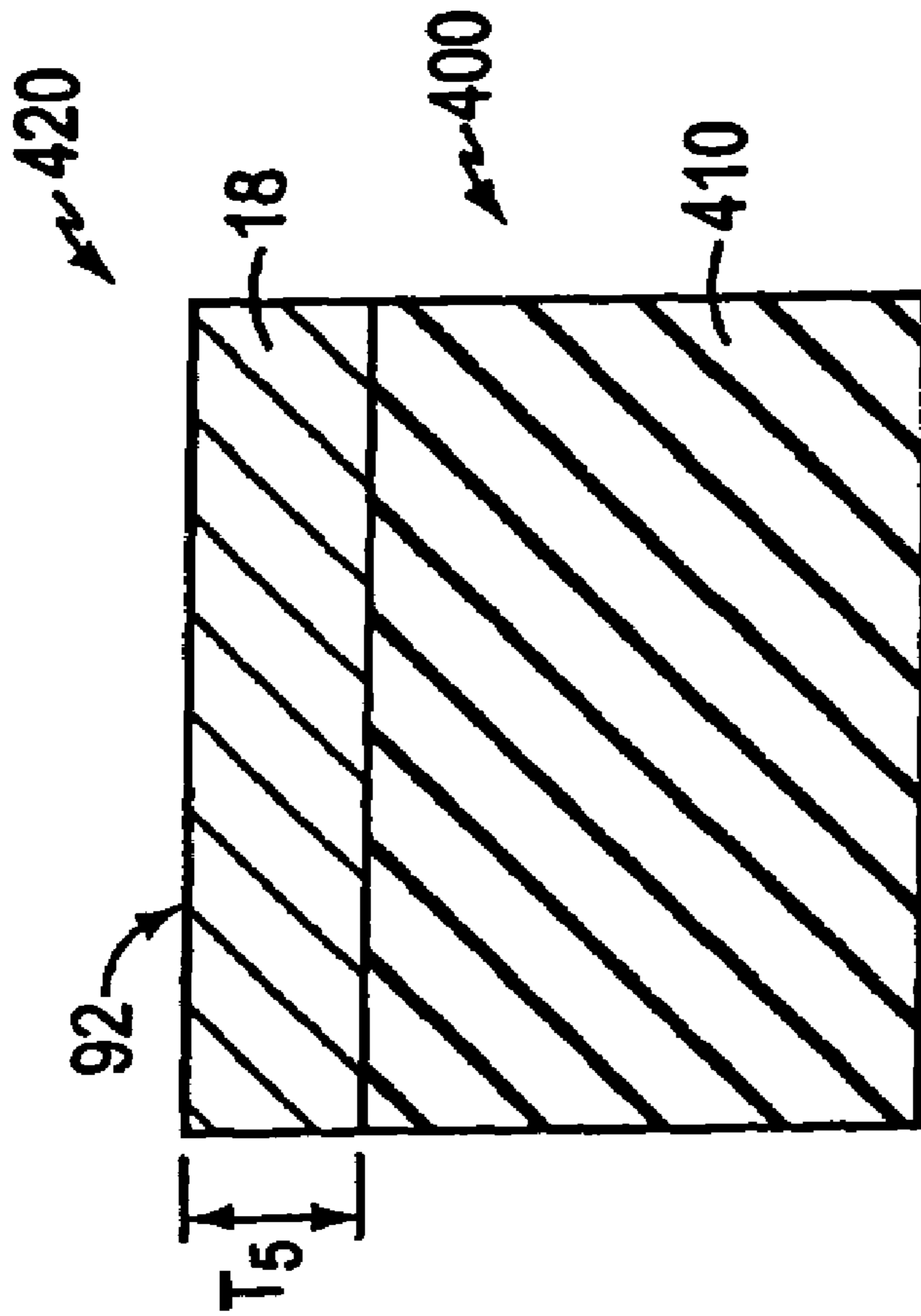

FIG. 12

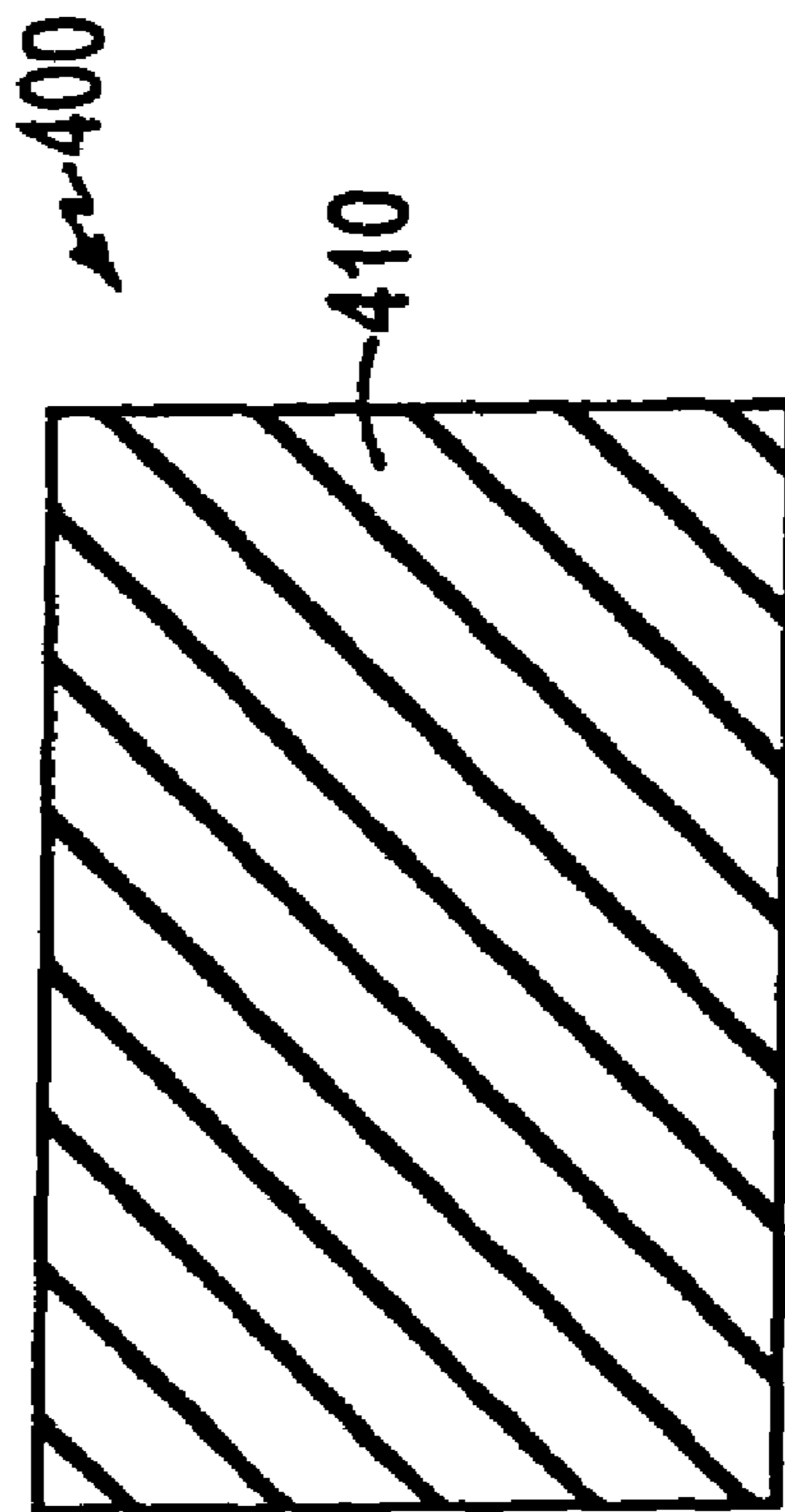

FIG. 13

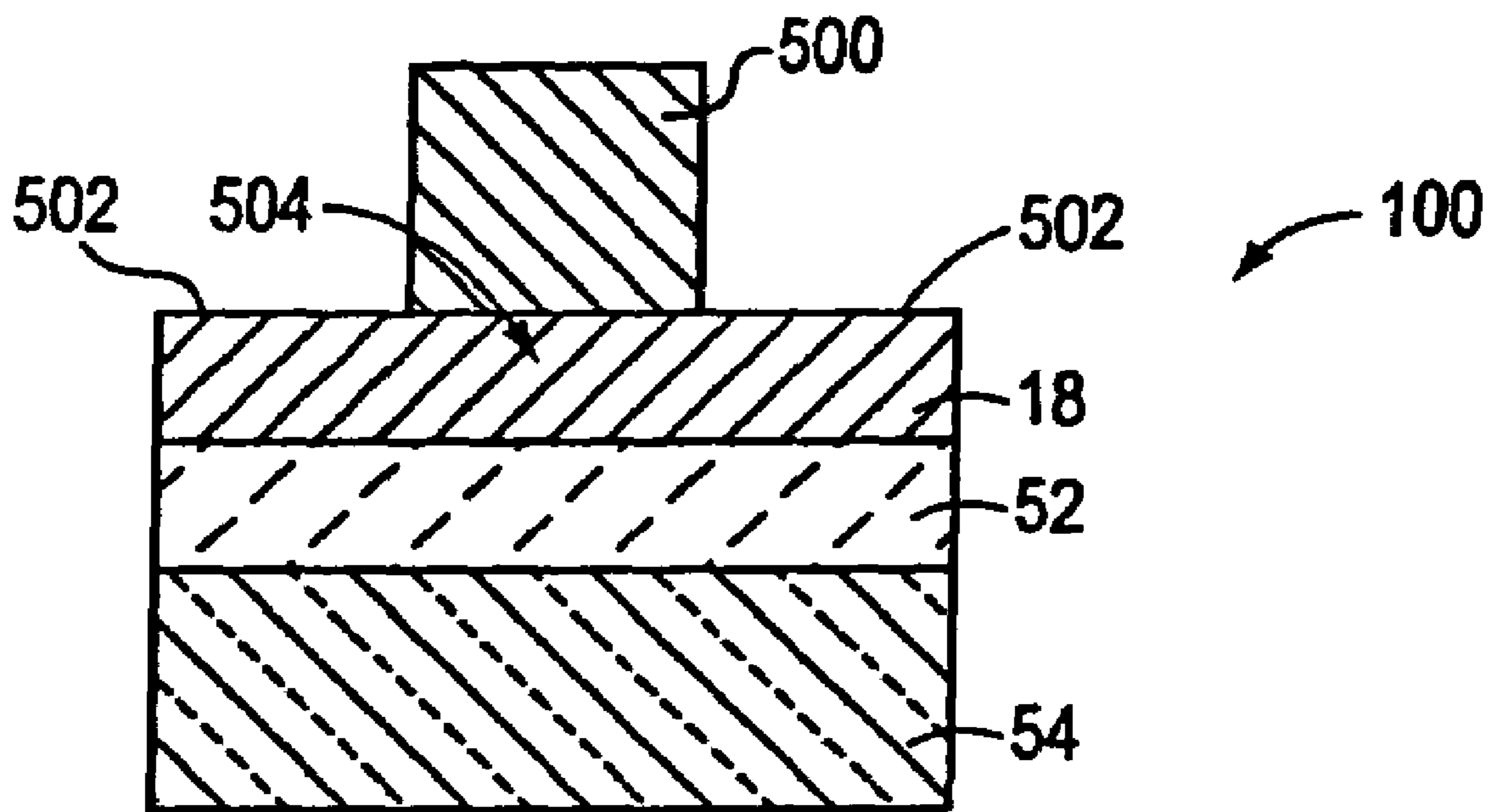

FIG. 14

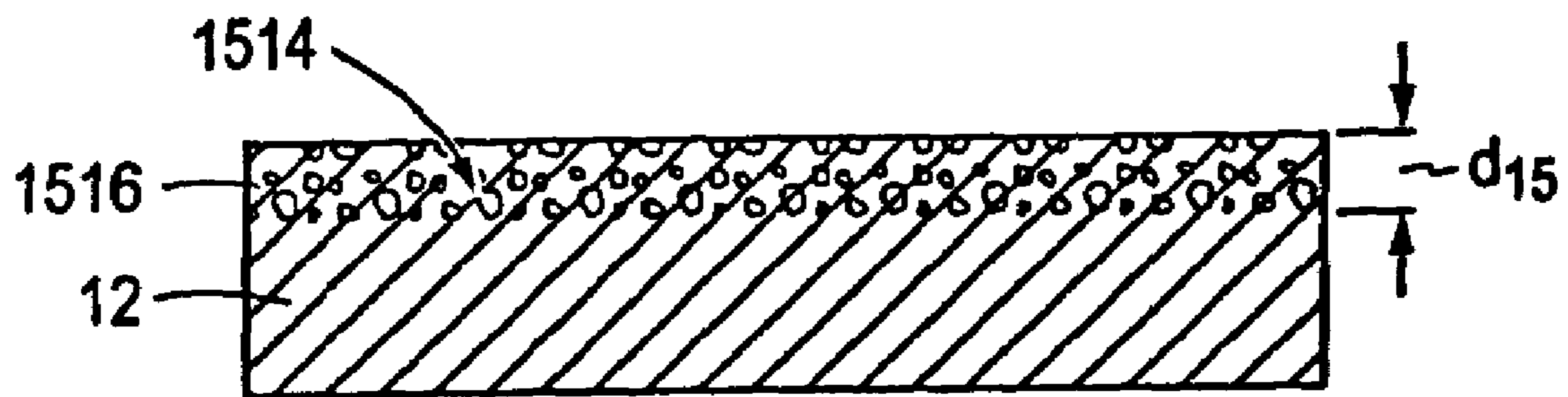

FIG. 15A

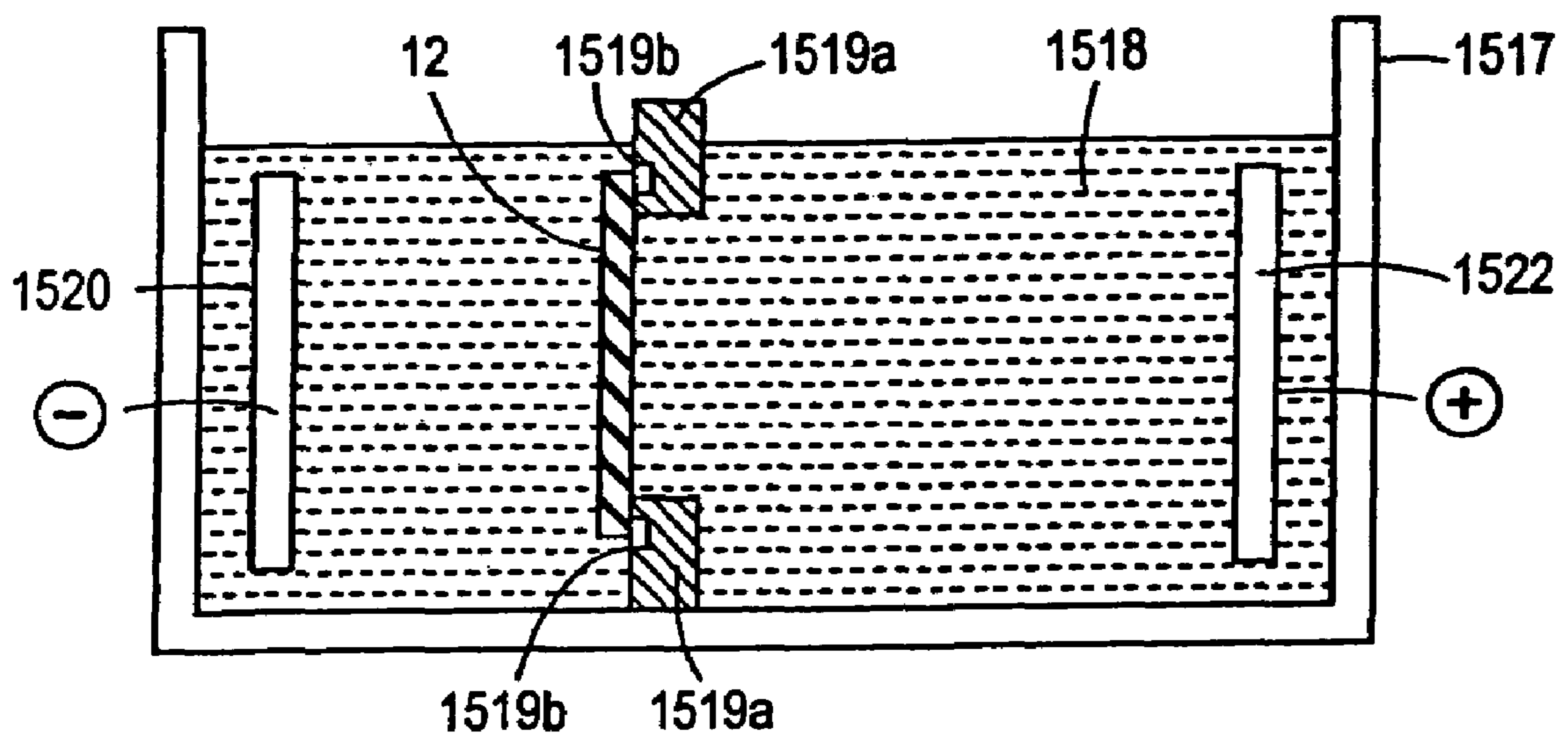

FIG. 15B

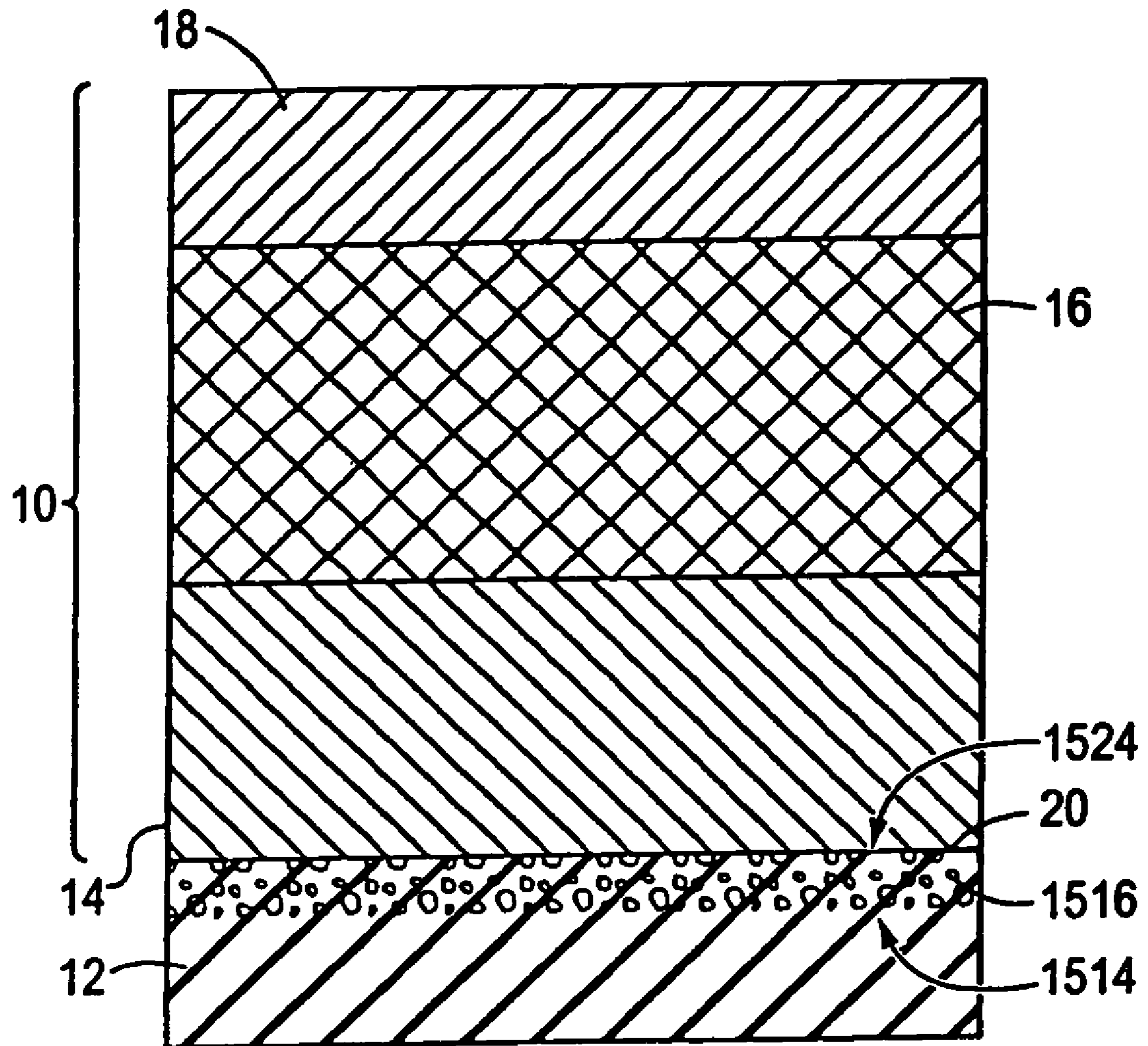

FIG. 15C

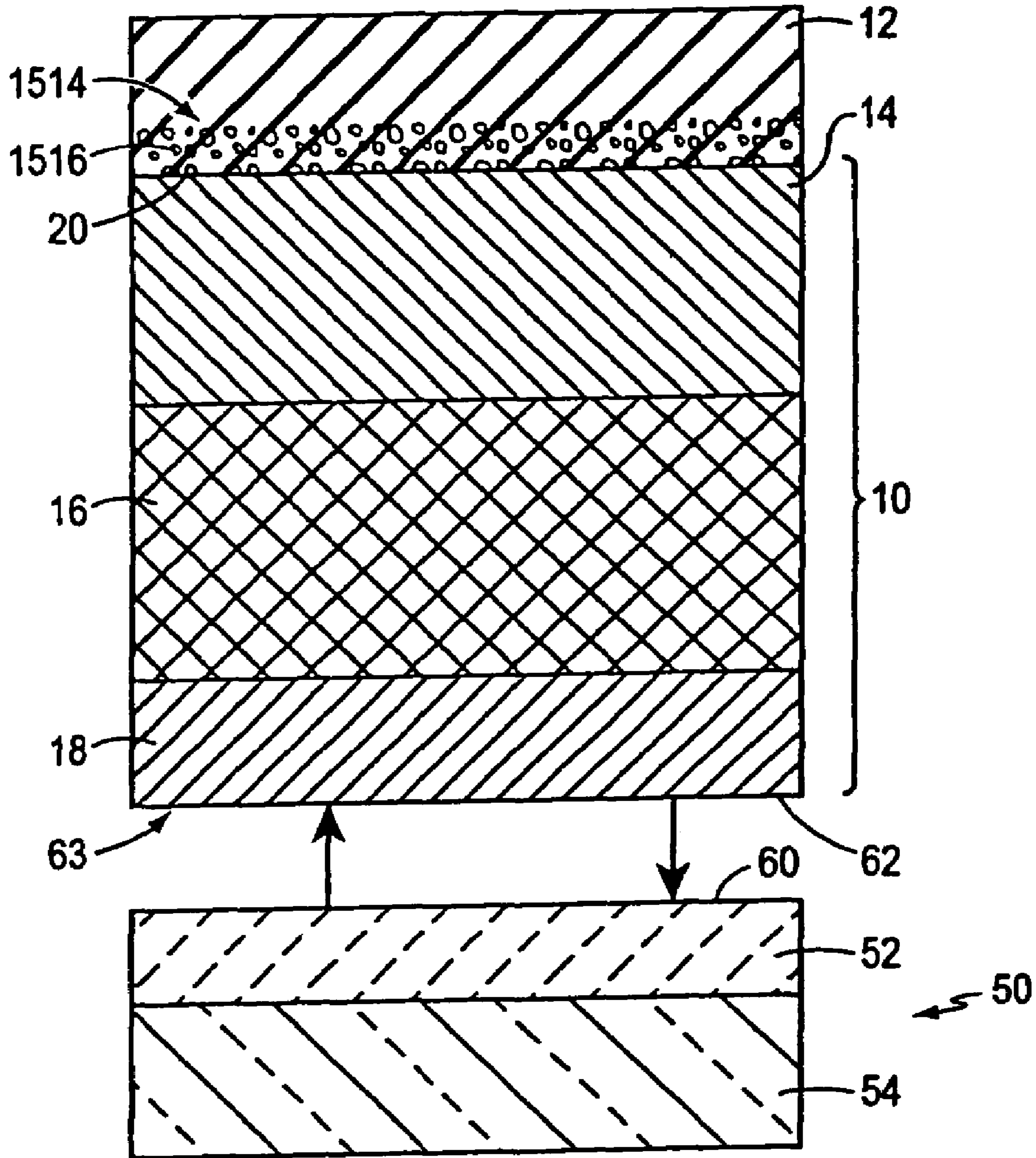

FIG. 15D

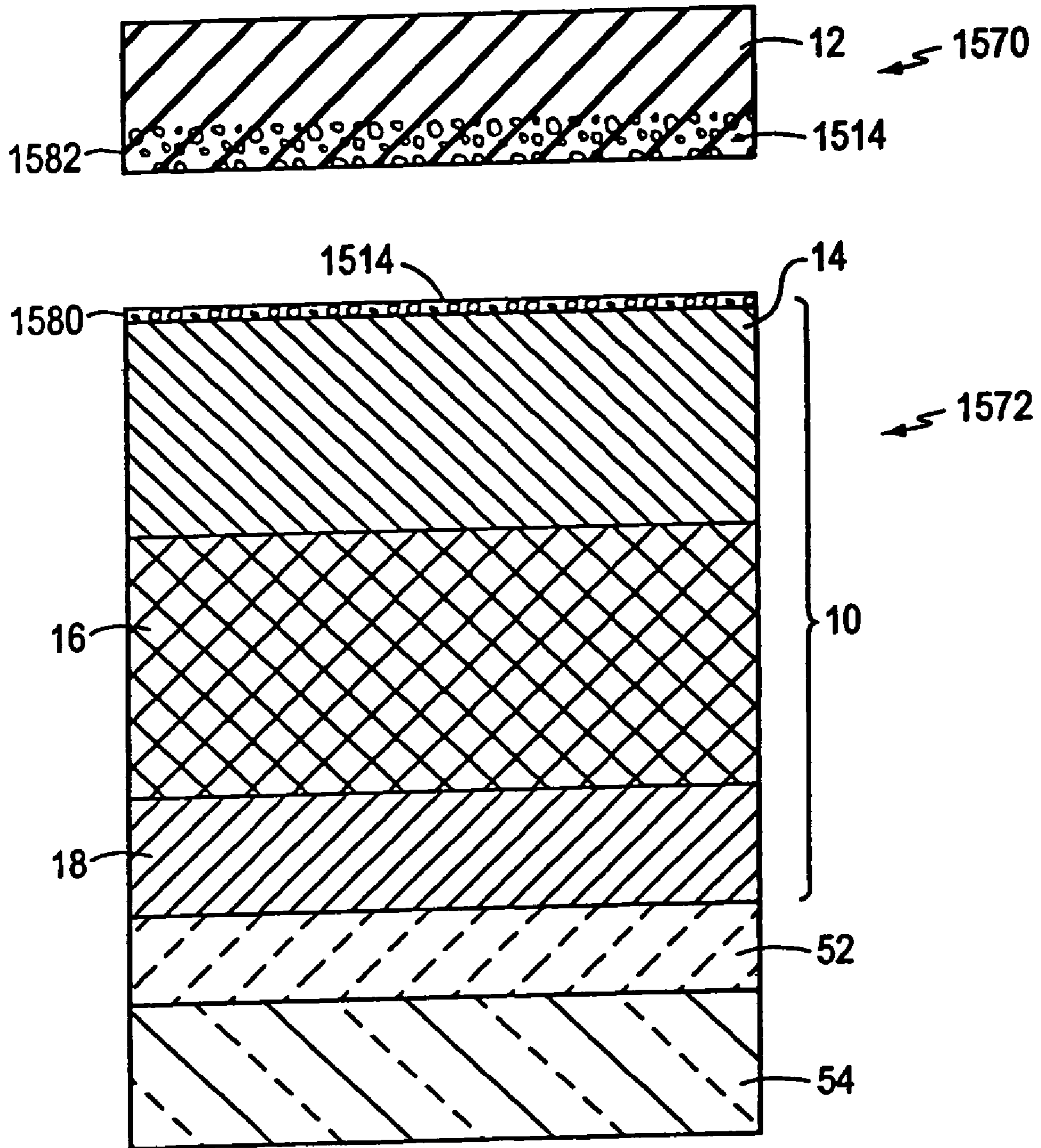

FIG. 15E

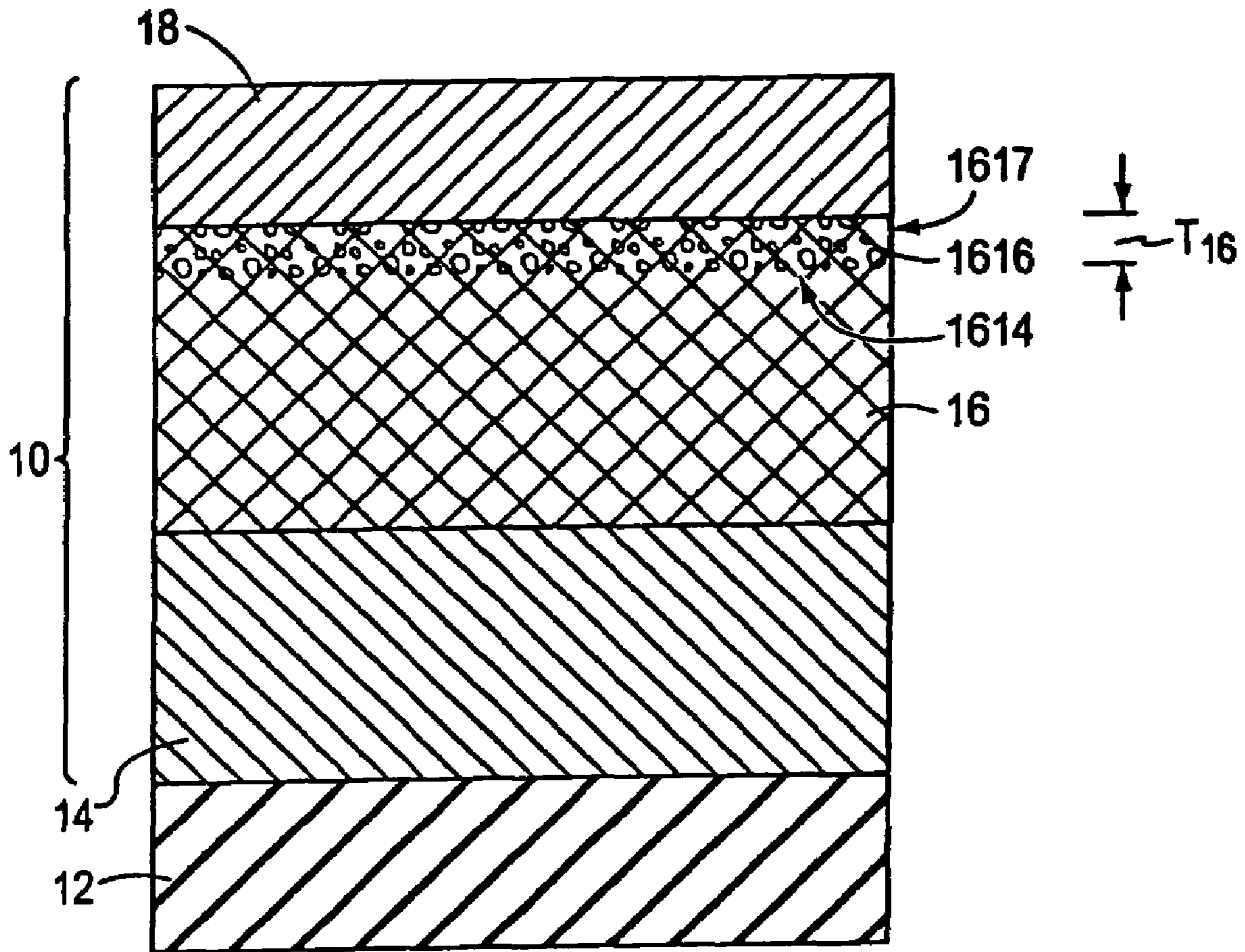

FIG. 16A

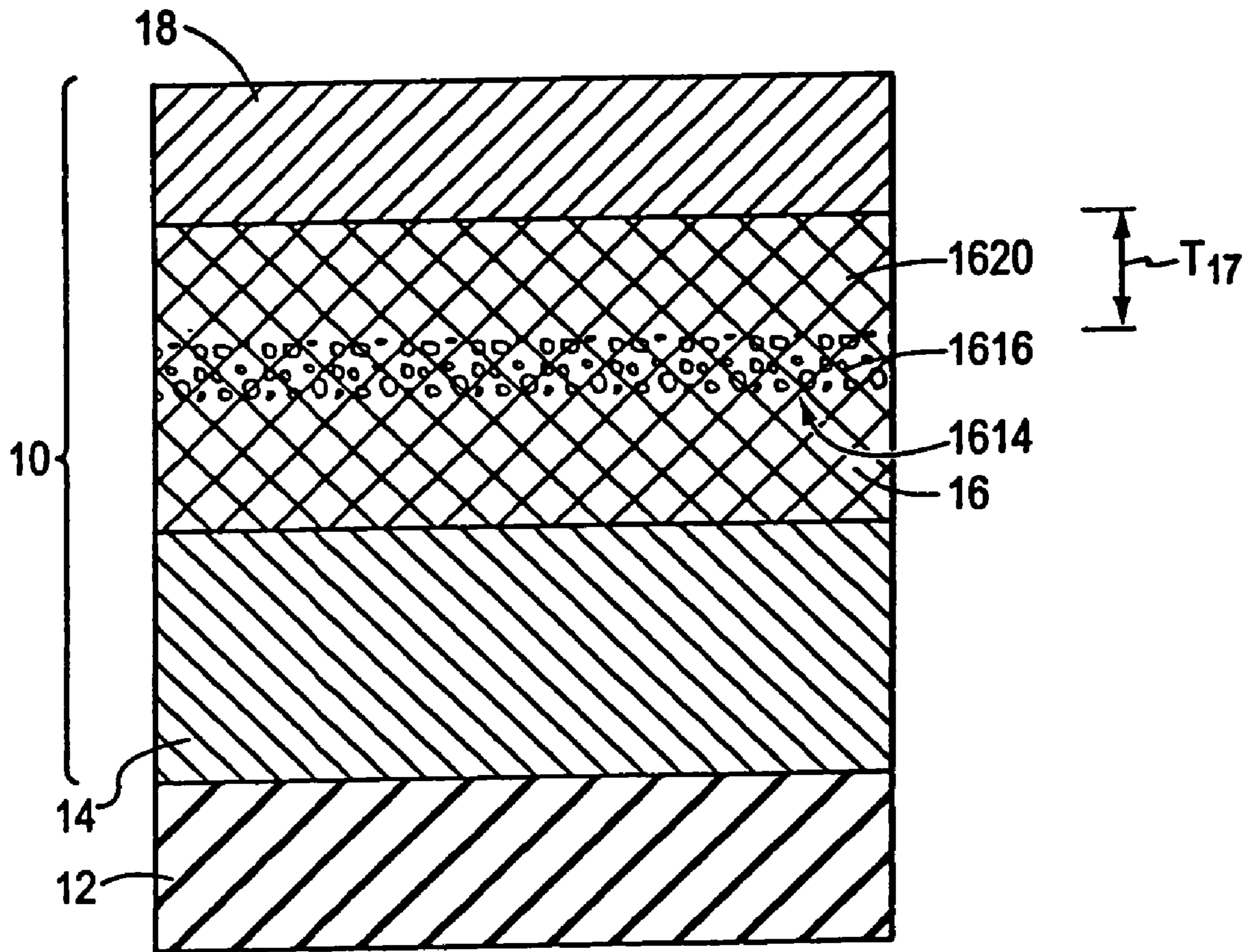

FIG. 16B

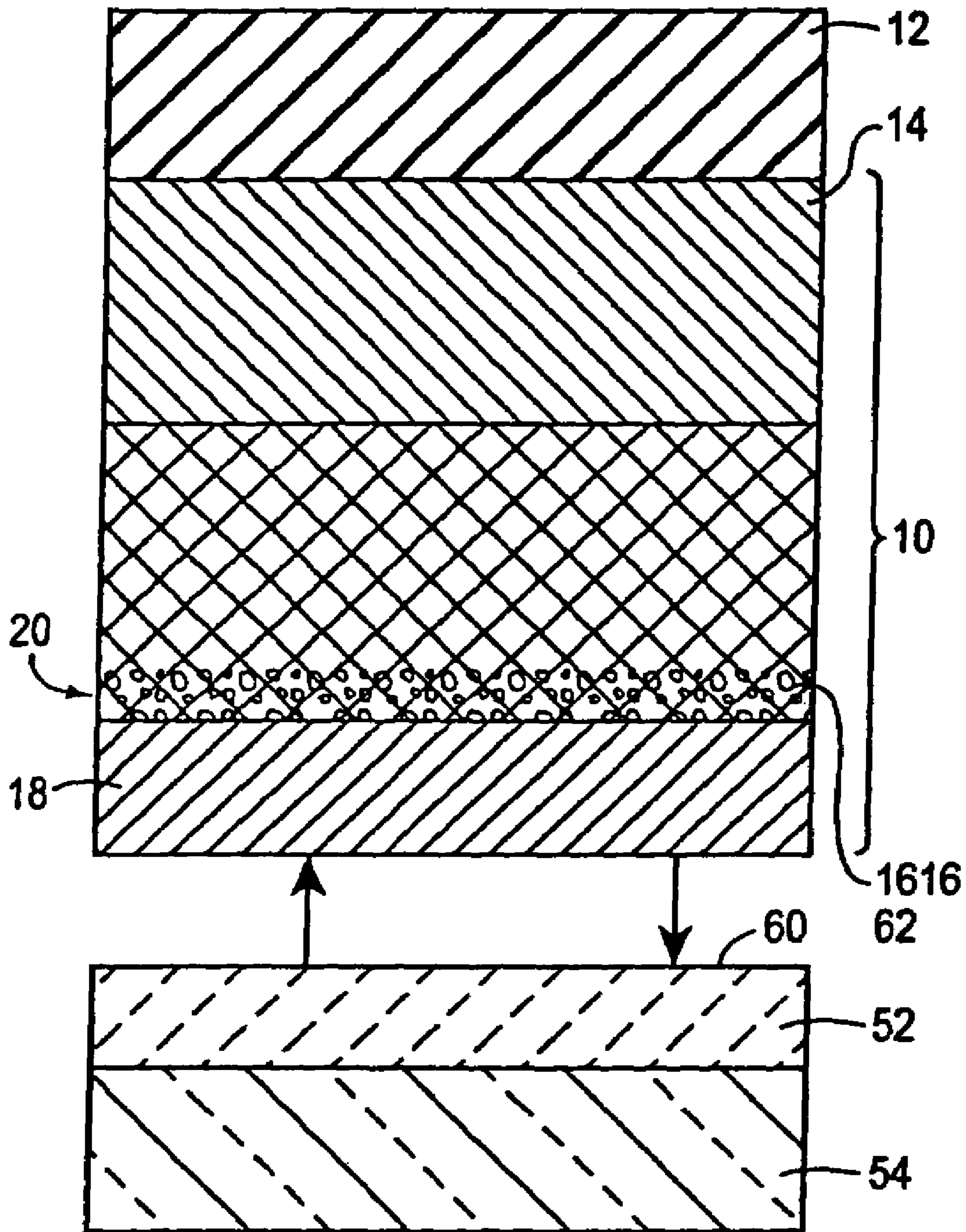

FIG. 16C

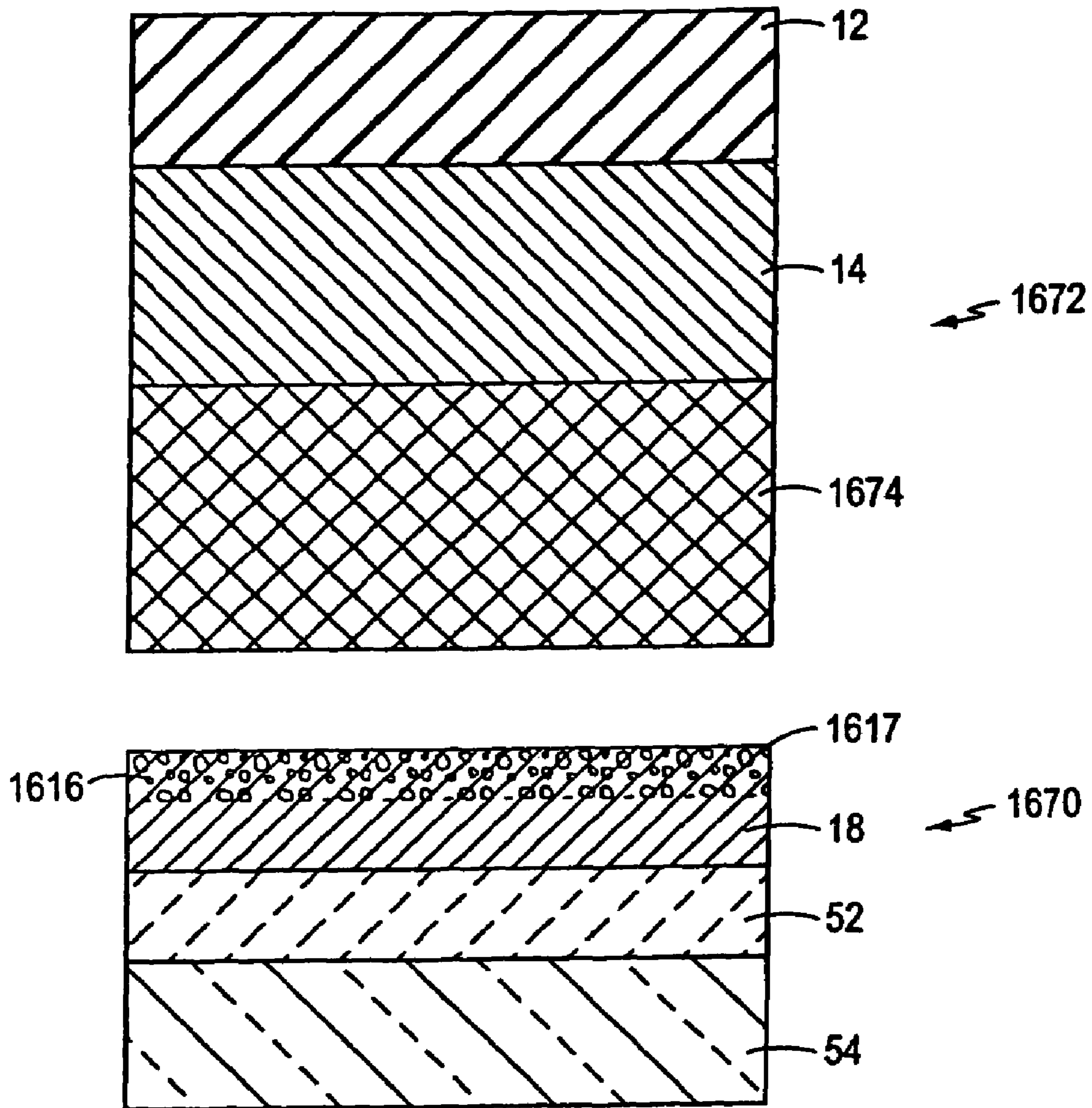

FIG. 16D

1

STRAINED-SEMICONDUCTOR-ON-INSULATOR DEVICE STRUCTURES WITH ELEVATED SOURCE/DRAIN REGIONS

RELATED APPLICATIONS

This application is a continuation application of U.S. Ser. No. 10/456,103, filed Jun. 6, 2003, which claims the benefit of U.S. Provisional Application 60/386,968 filed Jun. 7, 2002, U.S. Provisional Application 60/404,058 filed Aug. 15, 2002, and U.S. Provisional Application 60/416,000 filed Oct. 4, 2002; the entire disclosures of this nonprovisional utility patent application and these three provisional applications are hereby incorporated by reference.

FIELD OF THE INVENTION

This invention relates to devices and structures comprising strained semiconductor layers and insulator layers.

BACKGROUND

Strained silicon-on-insulator structures for semiconductor devices combine the benefits of two advanced approaches to performance enhancement: silicon-on-insulator (SOI) technology and strained silicon (Si) technology. The strained silicon-on-insulator configuration offers various advantages associated with the insulating substrate, such as reduced parasitic capacitances and improved isolation. Strained Si provides improved carrier mobilities. Devices such as strained Si metal-oxide-semiconductor field-effect transistors (MOSFETs) combine enhanced carrier mobilities with the advantages of insulating substrates.

Strained-silicon-on-insulator substrates are typically fabricated as follows. First, a relaxed silicon-germanium (SiGe) layer is formed on an insulator by one of several techniques such as separation by implantation of oxygen (SIMOX), wafer bonding and etch back; wafer bonding and hydrogen exfoliation layer transfer; or recrystallization of amorphous material. Then, a strained Si layer is epitaxially grown to form a strained-silicon-on-insulator structure, with strained Si disposed over SiGe. The relaxed-SiGe-on-insulator layer serves as the template for inducing strain in the Si layer. This induced strain is typically greater than 10^{-3} .

This structure has limitations. It is not conducive to the production of fully-depleted strained-semiconductor-on-insulator devices in which the layer over the insulating material must be thin enough [<300 angstroms (\AA)] to allow for full depletion of the layer during device operation. Fully depleted transistors may be the favored version of SOI for MOSFET technologies beyond the 90 nm technology node. The relaxed SiGe layer adds to the total thickness of this layer and thus makes it difficult to achieve the thicknesses required for fully depleted silicon-on-insulator device fabrication. The relaxed SiGe layer is not required if a strained Si layer can be produced directly on the insulating material. Thus, there is a need for a method to produce strained silicon—or other semiconductor—layers directly on insulating substrates.

SUMMARY

The present invention includes a strained-semiconductor-on-insulator (SSOI) substrate structure and methods for fabricating the substrate structure. MOSFETs fabricated on this substrate will have the benefits of SOI MOSFETs as well as the benefits of strained Si mobility enhancement. By eliminating the SiGe relaxed layer traditionally found beneath the

2

strained Si layer, the use of SSOI technology is simplified. For example, issues such as the diffusion of Ge into the strained Si layer during high temperature processes are avoided.

This approach enables the fabrication of well-controlled, epitaxially-defined, thin strained semiconductor layers directly on an insulator layer. Tensile strain levels of $\sim 10^{-3}$ or greater are possible in these structures, and are not diminished after thermal anneal cycles. In some embodiments, the strain-inducing relaxed layer is not present in the final structure, eliminating some of the key problems inherent to current strained Si-on-insulator solutions. This fabrication process is suitable for the production of enhanced-mobility substrates applicable to partially or fully depleted SSOI technology.

In an aspect, the invention features a structure including a substrate having a dielectric layer disposed thereon; and a first strained semiconductor layer disposed in contact with the dielectric layer, the semiconductor layer including approximately 100% germanium.

One or more of the following features may be included. The strained semiconductor layer may be compressively strained. The strained semiconductor layer may include a thin layer and the thin layer is disposed in contact with the dielectric layer. The thin layer may include silicon.

In another aspect, the invention features a substrate having a dielectric layer disposed thereon, a strained semiconductor layer disposed in contact with the dielectric layer, and a transistor. The transistor includes a source region and a drain region disposed in a portion of the strained semiconductor layer, and a gate disposed above the strained semiconductor layer and between the source and drain regions, the gate including a material selected from the group consisting of a doped semiconductor, a metal, and a metallic compound.

One or more of the following features may be included. The doped semiconductor may include polycrystalline silicon and/or polycrystalline silicon-germanium. The metal may include titanium, tungsten, molybdenum, tantalum, nickel, and/or iridium. The metal compound may include titanium nitride, titanium silicon nitride, tungsten nitride, tantalum nitride, tantalum silicide, nickel silicide, and/or iridium oxide. A contact layer may be disposed over at least a portion of the strained semiconductor layer, with a bottommost boundary of the contact layer being disposed above a bottommost boundary of the strained semiconductor layer. The contact layer may share an interface with the semiconductor layer.

In another aspect, the invention features a structure including a substrate having a dielectric layer disposed thereon, the dielectric layer having a melting point greater than about 1700°C ., and a strained semiconductor layer disposed in contact with the dielectric layer.

The following features may be included. The dielectric layer may include aluminum oxide, magnesium oxide, and/or silicon nitride.

In another aspect, the invention features a structure including a substrate having a dielectric layer disposed thereon; and a strained semiconductor layer disposed in contact with the dielectric layer. The strained semiconductor layer includes approximately 100% silicon and has a misfit dislocation density of less than about 10^5 cm^2 . In another aspect, the invention features a structure including a substrate having a dielectric layer disposed thereon, and a strained semiconductor layer disposed in contact with the dielectric layer. The strained semiconductor layer includes approximately 100% silicon and has a threading dislocation density selected from the range of about 10 dislocations/ cm^2 to about 10^7 dislocations/ cm^2 .

3

In another aspect, the invention features a structure including a substrate having a dielectric layer disposed thereon and a strained semiconductor layer disposed in contact with the dielectric layer. The semiconductor layer includes approximately 100% silicon and has a surface roughness selected from the range of approximately 0.01 nm to approximately 1 nm.

In another aspect, the invention features a substrate having a dielectric layer disposed thereon, and a strained semiconductor layer disposed in contact with the dielectric layer. The strained semiconductor layer includes approximately 100% silicon and has a thickness uniformity across the substrate of better than approximately $\pm 110\%$.

In another aspect, the invention features a structure including a substrate having a dielectric layer disposed thereon, and a strained semiconductor layer disposed in contact with the dielectric layer. The strained semiconductor layer includes approximately 100% silicon and has a thickness of less than approximately 200 Å.

In another aspect, the invention features a structure including a substrate having a dielectric layer disposed thereon, and a strained semiconductor layer disposed in contact with the dielectric layer. The semiconductor layer includes approximately 100% silicon and has a surface germanium concentration of less than approximately 1×10^{12} atoms/cm².

In another aspect, the invention features a structure including a substrate having a dielectric layer disposed thereon, and a strained semiconductor layer disposed in contact with the dielectric layer. An interface between the strained semiconductor layer and the dielectric layer has a density of bonding voids of less than 0.3 voids/cm².

In another aspect, the invention features a method for forming a structure, the method including providing a first substrate comprising a porous layer defining a cleave plane and having a first strained semiconductor layer formed thereon. The first strained semiconductor layer is bonded to an insulator layer disposed on a second substrate, and removing the first substrate from the first strained semiconductor layer by cleaving at the cleave plane, the strained semiconductor layer remaining bonded to the insulator layer.

In another aspect, the invention features a method for forming a structure, the method including forming a first relaxed layer over a first substrate, the first relaxed layer including a porous layer defining a cleave plane. A strained semiconductor layer is formed over the first relaxed layer. The first strained semiconductor layer is bonded to an insulator layer disposed on a second substrate. The first substrate is removed from the strained semiconductor layer by cleaving at the cleave plane, the strained semiconductor layer remaining bonded to the insulator layer.

One or more of the following features may be included. The porous layer may be disposed at a top portion of the first relaxed layer. A second relaxed layer may be formed over the first relaxed layer, with the strained semiconductor layer being formed over the second relaxed layer. The first relaxed layer may be planarized, e.g., by chemical-mechanical polishing, prior to forming the second relaxed layer. At least a portion of the porous layer may remain disposed on the first strained semiconductor layer after cleaving. The portion of the porous layer may be removed from the strained semiconductor layer after cleaving. The portion of the porous layer may be removed by cleaning with a wet chemical solution that may include, e.g., hydrogen peroxide and/or hydrofluoric acid. Removing the portion of the porous layer may include oxidation.

4

BRIEF DESCRIPTION OF DRAWINGS

FIGS. 1A, 1B, 2A, 2B, and 3-6 are schematic cross-sectional views of substrates illustrating a method for fabricating an SSOI substrate;

FIG. 7 is a schematic cross-sectional view illustrating an alternative method for fabricating the SSOI substrate illustrated in FIG. 6;

FIG. 8 is a schematic cross-sectional view of a transistor formed on the SSOI substrate illustrated in FIG. 6;

FIGS. 9-10 are schematic cross-sectional views of substrate(s) illustrating a method for fabricating an alternative SSOI substrate;

FIG. 11 is a schematic cross-sectional view of a substrate having several layers formed thereon;

FIGS. 12-13 are schematic cross-sectional views of substrates illustrating a method for fabricating an alternative strained semiconductor substrate;

FIG. 14 is a schematic cross-sectional view of the SSOI substrate illustrated in FIG. 6 after additional processing; and

FIGS. 15A-16D are schematic cross-sectional views of substrates illustrating alternative methods for fabricating an SSOI substrate.

Like-referenced features represent common features in corresponding drawings.

DETAILED DESCRIPTION

An SSOI structure may be formed by wafer bonding followed by cleaving. FIGS. 1A-2B illustrate formation of a suitable strained layer on a wafer for bonding, as further described below.

Referring to FIG. 1A, an epitaxial wafer 8 has a plurality of layers 10 disposed over a substrate 12. Substrate 12 may be formed of a semiconductor, such as Si, Ge, or SiGe. The plurality of layers 10 includes a graded buffer layer 14, which may be formed of $\text{Si}_{1-y}\text{Ge}_y$, with a maximum Ge content of, e.g., 10-80% (i.e., $y=0.1-0.8$) and a thickness T_1 of, for example, 1-8 micrometers (μm).

A relaxed layer 16 is disposed over graded buffer layer 14. Relaxed layer 16 may be formed of uniform $\text{Si}_{1-x}\text{Ge}_x$ having a Ge content of, for example, 10-80% (i.e., $x=0.1-0.8$), and a thickness T_2 of, for example, 0.2-2 μm . In some embodiments, $\text{Si}_{1-x}\text{Ge}_x$ may include $\text{Si}_{0.70}\text{Ge}_{0.30}$ and T_2 may be approximately 1.5 μm . Relaxed layer 16 may be fully relaxed, as determined by triple axis X-ray diffraction, and may have a threading dislocation density of $<1 \times 10^6$ dislocations/cm², as determined by etch pit density (EPD) analysis. Because threading dislocations are linear defects disposed within a volume of crystalline material, threading dislocation density may be measured as either the number of dislocations intersecting a unit area within a unit volume or the line length of dislocation per unit volume. Threading dislocation density therefore, may, be expressed in either units of dislocations/cm² or cm/cm³. Relaxed layer 16 may have a surface particle density of, e.g., less than about 0.3 particles/cm². Further, relaxed layer 16 produced in accordance with the present invention may have a localized light-scattering defect level of less than about 0.3 defects/cm² for particle defects having a size (diameter) greater than 0.13 microns, a defect level of about 0.2 defects/cm² for particle defects having a size greater than 0.16 microns, a defect level of about 0.1 defects/cm² for particle defects having a size greater than 0.2 microns, and a defect level of about 0.03 defects/cm² for defects having a size greater than 1 micron. Process optimization may enable reduction of the localized light-scattering defect levels to about 0.09 defects/cm² for particle defects having a size

greater than 0.09 microns and to 0.05 defects/cm² for particle defects having a size greater than 0.12 microns.

Substrate **12**, graded layer **14**, and relaxed layer **16** may be formed from various materials systems, including various combinations of group II, group III, group IV, group V, and group VI elements. For example, each of substrate **12**, graded layer **14**, and relaxed layer **16** may include a III-V compound. Substrate **12** may include gallium arsenide (GaAs), graded layer **14** and relaxed layer **16** may include indium gallium arsenide (InGaAs) or aluminum gallium arsenide (AlGaAs). These examples are merely illustrative, and many other material systems are suitable.

A strained semiconductor layer **18** is disposed over relaxed layer **16**. Strained layer **18** may include a semiconductor such as at least one of a group II, a group III, a group IV, a group V, and a group VI element. Strained semiconductor layer **18** may include, for example, Si, Ge, SiGe, GaAs, indium phosphide (InP), and/or zinc selenide (ZnSe). In some embodiments, strained semiconductor layer **18** may include approximately 100% Ge, and may be compressively strained. Strained semiconductor layer **18** comprising 100% Ge may be formed over, e.g., relaxed layer **16** containing uniform Si_{1-x}Ge_x having a Ge content of, for example, 50-80% (i.e., x=0.5-0.8), preferably 70% (x=0.7). Strained layer **18** has a thickness T₃ of, for example, 50-1000 Å. In an embodiment, T₃ may be approximately 200-500 Å.

Strained layer **18** may be formed by epitaxy, such as by atmospheric-pressure CVD (APCVD), low- (or reduced-) pressure CVD (LPCVD), ultra-high-vacuum CVD (UH-VCVD), by molecular beam epitaxy (MBE), or by atomic layer deposition (ALD). Strained layer **18** containing Si may be formed by CVD with precursors such as silane, disilane, or trisilane. Strained layer **18** containing Ge may be formed by CVD with precursors such as germane or digermane. The epitaxial growth system may be a single-wafer or multiple-wafer batch reactor. The growth system may also utilize a low-energy plasma to enhance layer growth kinetics. Strained layer **18** may be formed at a relatively low temperature, e.g., less than 700° C., to facilitate the definition of an abrupt interface **17** between strained layer **18** and relaxed layer **16**. This abrupt interface **17** may enhance the subsequent separation of strained layer **18** from relaxed layer **16**, as discussed below with reference to FIGS. **4** and **5**. Abrupt interface **17** is characterized by the transition of Si or Ge content (in this example) proceeding in at least 1 decade (order of magnitude in atomic concentration) per nanometer of depth into the sample. In an embodiment, this abruptness may be better than 2 decades per nanometer.

In an embodiment in which strained layer **18** contains substantially 100% Si, strained layer **18** may be formed in a dedicated chamber of a deposition tool that is not exposed to Ge source gases, thereby avoiding cross-contamination and improving the quality of the interface between strained layer **18** and relaxed layer **16**. Furthermore, strained layer **18** may be formed from an isotopically pure silicon precursor(s). Isotopically pure Si has better thermal conductivity than conventional Si. Higher thermal conductivity may help dissipate heat from devices subsequently formed on strained layer **18**, thereby maintaining the enhanced carrier mobilities provided by strained layer **18**.

After formation, strained layer **18** has an initial misfit dislocation density, of, for example, 0-10⁵ cm/cm². In an embodiment, strained layer **18** has an initial misfit dislocation density of approximately 0 cm/cm². Because misfit dislocations are linear defects generally lying within a plane between two crystals within an area, they may be measured in terms of total line length per unit area. Misfit dislocation density,

therefore, may be expressed in units of dislocations/cm or cm/cm². In one embodiment, strained layer **18** is tensilely strained, e.g., Si formed over SiGe. In another embodiment, strained layer **18** is compressively strained, e.g., Ge formed over SiGe.

Strained layer **18** may have a surface particle density of, e.g., less than about 0.3 particles/cm². As used herein, "surface particle density" includes not only surface particles but also light-scattering defects, and crystal-originated pits (COPs), and other defects incorporated into strained layer **18**. Further, strained layer **18** produced in accordance with the present invention may have a localized light-scattering defect level of less than about 0.3 defects/cm² for particle defects having a size (diameter) greater than 0.13 microns, a defect level of about 0.2 defects/cm² for particle defects having a size greater than 0.16 microns, a defect level of about 0.1 defects/cm² for particle defects having a size greater than 0.2 microns, and a defect level of about 0.03 defects/cm² for defects having a size greater than 1 micron. Process optimization may enable reduction of the localized light-scattering defect levels to about 0.09 defects/cm² for particle defects having a size greater than 0.09 microns and to 0.05 defects/cm² for particle defects having a size greater than 0.12 microns. These surface particles may be incorporated in strained layer **18** during the formation of strained layer **18**, or they may result from the propagation of surface defects from an underlying layer, such as relaxed layer **16**.

In alternative embodiments, graded layer **14** may be absent from the structure. Relaxed layer **16** may be formed in various ways, and the invention is not limited to embodiments having graded layer **14**. In other embodiments, strained layer **18** may be formed directly on substrate **12**. In this case, the strain in layer **18** may be induced by lattice mismatch between layer **18** and substrate **12**, induced mechanically, e.g., by the deposition of overlayers, such as Si₃N₄, or induced by thermal mismatch between layer **18** and a subsequently grown layer, such as a SiGe layer. In some embodiments, a uniform semiconductor layer (not shown), having a thickness of approximately 0.5 μm and comprising the same semiconductor material as substrate **12**, is disposed between graded buffer layer **14** and substrate **12**. This uniform semiconductor layer may be grown to improve the material quality of layers subsequently grown on substrate **12**, such as graded buffer layer **14**, by providing a clean, contaminant-free surface for epitaxial growth. In certain embodiments, relaxed layer **16** may be planarized prior to growth of strained layer **18** to eliminate the crosshatched surface roughness induced by graded buffer layer **14**. (See, e.g., M. T. Currie, et al., *Appl. Phys. Lett.*, 72 (14) p. 1718 (1998), incorporated herein by reference.) The planarization may be performed by a method such as chemical mechanical polishing (CMP), and may improve the quality of a subsequent bonding process (see below) because it minimizes the wafer surface roughness and increases wafer flatness, thus providing a greater surface area for bonding.

Referring to FIG. **1B**, after planarization of relaxed layer **16**, a relaxed semiconductor regrowth layer **19** including a semiconductor such as SiGe may be grown on relaxed layer **16**, thus improving the quality of subsequent strained layer **18** growth by ensuring a clean surface for the growth of strained layer **18**. Growing on this clean surface may be preferable to growing strained material, e.g., silicon, on a surface that is possibly contaminated by oxygen and carbon from the planarization process. The conditions for epitaxy of the relaxed semiconductor regrowth layer **19** on the planarized relaxed layer **16** should be chosen such that surface roughness of the resulting structure, including layers formed over regrowth layer **19**, is minimized to ensure a surface suitable for subse-

quent high quality bonding. High quality bonding may be defined as the existence of a bond between two wafers that is substantially free of bubbles or voids at the interface. Measures that may help ensure a smooth surface for strained layer **18** growth, thereby facilitating bonding, include substantially matching a lattice of the semiconductor regrowth layer **19** to that of the underlying relaxed layer **16**, by keeping the regrowth thickness below approximately 1 μm , and/or by keeping the growth temperature below approximately 850° C. for at least a portion of the semiconductor layer **19** growth. It may also be advantageous for relaxed layer **16** to be substantially free of particles or areas with high threading dislocation densities (i.e., threading dislocation pile-ups) which could induce non-planarity in the regrowth and decrease the quality of the subsequent bond.

Referring to FIG. 2A, in an embodiment, hydrogen ions are implanted into relaxed layer **16** to define a cleave plane **20**. This implantation is similar to the SMARTCUT process that has been demonstrated in silicon by, e.g., SOITEC, based in Grenoble, France. Implantation parameters may include implantation of hydrogen (H_2^+) to a dose of 2.5×10^{16} ions/ cm^2 at an energy of, e.g., 50-100 keV. For example, H_2^+ may be implanted at an energy of 75 keV and a dose of 4×10^{16} ions/ cm^2 through strained layer **18** into relaxed layer **16**. In alternative embodiments, it may be favorable to implant at energies less than 50 keV to decrease the depth of cleave plane **20** and decrease the amount of material subsequently removed during the cleaving process (see discussion below with reference to FIG. 4). In an alternative embodiment, other implanted species may be used, such as H^+ or He^+ , with the dose and energy being adjusted accordingly. The implantation may also be performed prior to the formation of strained layer **18**. Then, the subsequent growth of strained layer **18** is preferably performed at a temperature low enough to prevent premature cleaving along cleave plane **20**, i.e., prior to the wafer bonding process. This cleaving temperature is a complex function of the implanted species, implanted dose, and implanted material. Typically, premature cleaving may be avoided by maintaining a growth temperature below approximately 500° C.

In some embodiments, such as when strained layer **18** comprises nearly 100% Ge, a thin layer **21** of another material, such as Si, may be formed over strained layer **18** prior to bonding (see discussion with respect to FIG. 3). This thin layer **21** may be formed to enhance subsequent bonding of strained layer **18** to an insulator, such as an oxide. Thin layer **21** may have a thickness T_{21} of, for example, 0.5-5 nm.

In some embodiments, strained layer **18** may be planarized by, e.g., CMP, to improve the quality of the subsequent bond. Strained layer **18** may have a low surface roughness, e.g., less than 0.5 nm root mean square (RMS). Referring to FIG. 2B, in some embodiments, a dielectric layer **22** may be formed over strained layer **18** prior to ion implantation into relaxed layer **16** to improve the quality of the subsequent bond. Dielectric layer **22** may be, e.g., silicon dioxide (SiO_2) deposited by, for example, LPCVD or by high density plasma (HDP). An LPCVD deposited SiO_2 layer may be subjected to a densification step at elevated temperature. Suitable conditions for this densification step may be, for example, a 10 minute anneal at 800° C. in a nitrogen ambient. Alternatively, dielectric layer **22** may include low-temperature oxide (LTO), which may be subsequently densified at elevated temperature in nitrogen or oxygen ambients. Suitable conditions for this densification step can be a 10 minute anneal at 800° C. in an oxygen ambient. Dielectric layer **22** may be planarized by, e.g., CMP to improve the quality of the subsequent bond. In an alternative embodiment, it may be advantageous for

dielectric layer **22** to be formed from thermally grown SiO_2 in order to provide a high quality semiconductor/dielectric interface in the final structure. In an embodiment, strained layer **18** comprises approximately 100% Ge and dielectric layer **22** comprises, for example, germanium dioxide (GeO_2); germanium oxynitride (GeON); a high-k insulator having a higher dielectric constant than that of SiO_2 such as hafnium oxide (HfO_2) or hafnium silicate (HfSiON , HfSiO_4); or a multilayer structure including GeO_2 and SiO_2 . Ge has an oxidation behavior different from that of Si, and the deposition methods may be altered accordingly.

Referring to FIG. 3, epitaxial wafer **8** is bonded to a handle wafer **50**. Either handle wafer **50**, epitaxial wafer **8**, or both have a top dielectric layer (see, e.g., dielectric layer **22** in FIG. 2B) to facilitate the bonding process and to serve as an insulator layer in the final substrate structure. Handle wafer **50** may have a dielectric layer **52** disposed over a semiconductor substrate **54**. Dielectric layer **52** may include, for example, SiO_2 . In an embodiment, dielectric layer **52** includes a material having a melting point (T_m) higher than a T_m of pure SiO_2 , i.e., higher than 1700° C. Examples of such materials are silicon nitride (Si_3N_4), aluminum oxide, magnesium oxide, etc. Using dielectric layer **52** with a high T_m helps prevent possible relaxation of the transferred strained semiconductor layer **18** that may occur during subsequent processing, due to softening of the underlying dielectric layer **52** at temperatures typically used during device fabrication (approximately 1000-1200° C.). In other embodiments, handle wafer **50** may include a combination of a bulk semiconductor material and a dielectric layer, such as a silicon on insulator substrate. Semiconductor substrate **54** includes a semiconductor material such as, for example, Si, Ge, or SiGe.

Handle wafer **50** and epitaxial wafer **8** are cleaned by a wet chemical cleaning procedure to facilitate bonding, such as by a hydrophilic surface preparation process to assist the bonding of a semiconductor material, e.g., strained layer **18**, to a dielectric material, e.g., dielectric layer **52**. For example, a suitable prebonding surface preparation cleaning procedure could include a modified megasonic RCA SC1 clean containing ammonium hydroxide, hydrogen peroxide, and water ($\text{NH}_4\text{OH}:\text{H}_2\text{O}_2:\text{H}_2\text{O}$) at a ratio of 1:4:20 at 60° C. for 10 minutes, followed by a deionized (DI) water rinse and spin dry. The wafer bonding energy should be strong enough to sustain the subsequent layer transfer (see FIG. 4). In some embodiments, top surfaces **60**, **62** of handle wafer **50** and epitaxial wafer **8**, including a top surface **63** of strained semiconductor layer **18**, may be subjected to a plasma activation, either before, after, or instead of a wet clean, to increase the bond strength. The plasma environment may include at least one of the following species: oxygen, ammonia, argon, nitrogen, diborane, and phosphine. After an appropriate cleaning step, handle wafer **50** and epitaxial wafer **8** are bonded together by bringing top surfaces **60**, **62** in contact with each other at room temperature. The bond strength may be greater than 1000 mJ/ m^2 , achieved at a low temperature, such as less than 600° C.

Referring to FIG. 4 as well as to FIG. 3, a split is induced at cleave plane **20** by annealing handle wafer **50** and epitaxial wafer **8** after they are bonded together. This split may be induced by an anneal at 300-700° C., e.g., 550° C., inducing hydrogen exfoliation layer transfer (i.e., along cleave plane **20**) and resulting in the formation of two separate wafers **70**, **72**. One of these wafers (**70**) has a first portion **80** of relaxed layer **16** (see FIG. 1A) disposed over strained layer **18**. Strained layer **18** is in contact with dielectric layer **52** on semiconductor substrate **54**. The other of these wafers (**72**) includes substrate **12**, graded layer **14**, and a remaining por-

tion **82** of relaxed layer **16**. In some embodiments, wafer splitting may be induced by mechanical force in addition to or instead of annealing. If necessary, wafer **70** with strained layer **18** may be annealed further at 600-900° C., e.g., at a temperature greater than 800° C., to strengthen the bond between the strained layer **18** and dielectric layer **52**. In some embodiments, this anneal is limited to an upper temperature of about 900° C. to avoid the destruction of a strained Si/relaxed SiGe heterojunction by diffusion. Wafer **72** may be planarized, and used as starting substrate **8** for growth of another strained layer **18**. In this manner, wafer **72** may be “recycled” and the process illustrated in FIGS. 1A-5 may be repeated. An alternative “recycling” method may include providing relaxed layer **16** that is several microns thick and repeating the process illustrated in FIGS. 1A-5, starting with the formation of strained layer **18**. Because the formation of this thick relaxed layer **16** may lead to bowing of substrate **12**, a layer including, e.g., oxide or nitride, may be formed on the backside of substrate **12** to counteract the bowing. Alternatively substrate **12** may be pre-bowed when cut and polished, in anticipation of the bow being removed by the formation of thick relaxed layer **16**.

Referring to FIG. 4 as well as to FIG. 5, relaxed layer portion **80** is removed from strained layer **18**. In an embodiment, removal of relaxed layer portion **80**, containing, e.g., SiGe, includes oxidizing the relaxed layer portion **80** by wet (steam) oxidation. For example, at temperatures below approximately 800° C., such as temperatures between 600-750° C., wet oxidation will oxidize SiGe much more rapidly than Si, such that the oxidation front will effectively stop when it reaches the strained layer **18**, in embodiments in which strained layer **18** includes Si. The difference between wet oxidation rates of SiGe and Si may be even greater at lower temperatures, such as approximately 400° C.-600° C. Good oxidation selectivity is provided by this difference in oxidation rates, i.e., SiGe may be efficiently removed at low temperatures with oxidation stopping when strained layer **18** is reached. This wet oxidation results in the transformation of SiGe to a thermal insulator **90**, e.g., $\text{Si}_x\text{Ge}_y\text{O}_z$. The thermal insulator **90** resulting from this oxidation is removed in a selective wet or dry etch, e.g., wet hydrofluoric acid. In some embodiments, it may be more economical to oxidize and strip several times, instead of just once.

In certain embodiments, wet oxidation may not completely remove the relaxed layer portion **80**. Here, a localized rejection of Ge may occur during oxidation, resulting in the presence of a residual Ge-rich SiGe region at the oxidation front, on the order of, for example, several nanometers in lateral extent. A surface clean may be performed to remove this residual Ge. For example, the residual Ge may be removed by a dry oxidation at, e.g., 600° C., after the wet oxidation and strip described above. Another wet clean may be performed in conjunction with—or instead of—the dry oxidation. Examples of possible wet etches for removing residual Ge include a Piranha etch, i.e., a wet etch that is a mixture of sulfuric acid and hydrogen peroxide ($\text{H}_2\text{SO}_4:\text{H}_2\text{O}_2$) at a ratio of, for example, 3:1. An HF dip may be performed after the Piranha etch. Alternatively, an RCA SC1 clean may be used to remove the residual Ge. The process of Piranha or RCA SC1 etching and HF removal of resulting oxide may be repeated more than once. In an embodiment, relaxed layer portion including, e.g., SiGe, is removed by etching and annealing under a hydrochloric acid (HCl) ambient.

In the case of a strained Si layer, the surface Ge concentration of the final strained Si surface is preferably less than about 1×10^{12} atoms/cm² when measured by a technique such as total reflection x-ray fluorescence (TXRF) or the combi-

nation of vapor phase decomposition (VPD) with a spectroscopy technique such as graphite furnace atomic absorption spectroscopy (GFAAS) or inductively-coupled plasma mass spectroscopy (ICP-MS). In some embodiments, after cleaving, a planarization step or a wet oxidation step may be performed to remove a portion of the damaged relaxed layer portion **80** as well as to increase the smoothness of its surface. A smoother surface may improve the uniformity of subsequent complete removal of a remainder of relaxed layer portion **80** by, e.g., wet chemical etching. After removal of relaxed layer portion **80**, strained layer **18** may be planarized. Planarization of strained layer **18** may be performed by, e.g., CMP; an anneal at a temperature greater than, for example, 800° C., in a hydrogen (H_2) or hydrochloric acid (HCl) containing ambient; or cluster ion beam smoothing.

Referring to FIG. 6, a SSOI substrate **100** has strained layer **18** disposed over an insulator, such as dielectric layer **52** formed on semiconductor substrate **54**. Strained layer **18** has a thickness T_4 selected from a range of, for example, 50-1000 Å, with a thickness uniformity of better than approximately $\pm 5\%$ and a surface roughness of less than approximately 20 Å. Dielectric layer **52** has a thickness T_{52} selected from a range of, for example, 500-3000 Å. In an embodiment, strained layer **18** includes approximately 100% Si or 100% Ge having one or more of the following material characteristics: misfit dislocation density of, e.g., $0-10^5$ cm/cm²; a threading dislocation density of about 10^1-10^7 dislocations/cm²; a surface roughness of approximately 0.01-1 nm RMS; and a thickness uniformity across SSOI substrate **100** of better than approximately $\pm 10\%$ of a mean desired thickness; and a thickness T_4 of less than approximately 200 Å. In an embodiment, SSOI substrate **100** has a thickness uniformity of better than approximately $\pm 5\%$ of a mean desired thickness.

In an embodiment, dielectric layer **52** has a T_m greater than that of SiO_2 . During subsequent processing, e.g., MOSFET formation, SSOI substrate **100** may be subjected to high temperatures, i.e., up to 1100° C. High temperatures may result in the relaxation of strained layer **18** at an interface between strained layer **18** and dielectric layer **52**. The use of dielectric layer with a T_m greater than 1700° C. may help keep strained layer **18** from relaxing at the interface between strained layer **18** and dielectric layer **52** when SSOI substrate is subjected to high temperatures.

In an embodiment, the misfit dislocation density of strained layer **18** may be lower than its initial dislocation density. The initial dislocation density may be lowered by, for example, performing an etch of a top surface **92** of strained layer **18**. This etch may be a wet etch, such as a standard microelectronics clean step such as an RCA SC1, i.e., hydrogen peroxide, ammonium hydroxide, and water ($\text{H}_2\text{O}_2+\text{NH}_4\text{OH}+\text{H}_2\text{O}$), which at, e.g., 80° C. may remove silicon.

The presence of surface particles on strained layer **18**, as described above with reference to FIG. 1A, may result in the formation of bonding voids at an interface **102** between strained layer **18** and dielectric layer **52**. These bonding voids may have a density equivalent to the density of surface particles formed on strained layer **18**, e.g., less than about 0.3 voids/cm².

In some embodiments, strained semiconductor layer **18** includes Si and is substantially free of Ge; further, any other layer disposed in contact with strained semiconductor layer **18** prior to device processing, e.g., dielectric layer **52**, is also substantially free of Ge.

Referring to FIG. 7, in an alternative embodiment, relaxed layer portion **80** may be removed by a selective wet etch that stops at the strained layer **18** to obtain SSOI substrate **100** (see FIG. 6). In embodiments in which relaxed layer portion **80**

contains SiGe, a suitable selective SiGe wet etch may be a solution containing nitric acid (HNO₃) and dilute HF at a ratio of 3:1 or a solution containing H₂O₂, HF, and acetic acid (CH₃COOH) at a ratio of 2:1:3. Alternatively, relaxed layer portion **80** may be removed by a dry etch that stops at strained layer **18**. In some embodiments, relaxed layer portion **80** may be removed completely or in part by a chemical-mechanical polishing step or by mechanical grinding.

Strained semiconductor-on-insulator substrate **100** may be further processed by CMOS SOI MOSFET fabrication methods. For example, referring to FIG. **8A**, a transistor **200** may be formed on SSOI substrate **100**. Forming transistor **200** includes forming a gate dielectric layer **210** above strained layer **18** by, for example, growing an SiO₂ layer by thermal oxidation. Alternatively, gate dielectric layer **210** may include a high-k material with a dielectric constant higher than that of SiO₂, such as HfO₂, HfSiON, or HfSiO₄. In some embodiments, gate dielectric layer **210** may be a stacked structure, e.g., a thin SiO₂ layer capped with a high-k material. A gate **212** is formed over gate dielectric layer **210**. Gate **212** may be formed of a conductive material, such as doped semiconductor, e.g., polycrystalline Si or polycrystalline SiGe; a metal, e.g., titanium (Ti), tungsten (W), molybdenum (Mo), tantalum (Ta), nickel (Ni), or iridium (Ir); or metal compounds, e.g., titanium nitride (TiN), titanium silicon nitride (TiSiN), tungsten nitride (WN), tantalum nitride (TaN), tantalum silicide (TaSi), nickel silicide (NiSi), or iridium oxide (IrO₂), that provide an appropriate workfunction. A source region **214** and a drain region **216** are formed in a portion **218** of strained semiconductor layer **18**, proximate gate dielectric layer **210**. Source and drain regions **214**, **216** may be formed by, e.g., ion implantation of either n-type or p-type dopants.

In some embodiments, strained semiconductor layer **18** may be compressively strained when, for example, layer **18** includes strained Ge. Compressively strained layers may be prone to undulation when subjected to large temperature changes. The risk of such undulation may be reduced by reducing the thermal budget of a process for fabricating devices, such as transistor **200**. The thermal budget may be reduced by, for example, using atomic layer deposition (ALD) to deposit gate dielectric layer **210**. Furthermore, a maximum temperature for forming gate **212** may be limited to, e.g., 600° C. by, for example, the use of materials comprising metal or metal compounds, rather than polysilicon or other gate materials that may require higher formation and/or dopant activation temperatures.

Referring to FIG. **8B**, a transistor **250** formed on SSOI substrate **100** may have an elevated source region and an elevated drain region proximate a first and a second sidewall spacer **252**, **254**. These elevated regions may be formed as follows. A semiconductor layer **256a-256c** is formed selectively on exposed silicon surfaces, i.e., on top surface **258** of a gate **259** containing silicon, a top surface **260** of a source **262** defined in strained layer **18**, and top surface **264** of a drain **266** defined in strained layer **18**. In an embodiment, semiconductor layer **256a-256c** is an epitaxial layer, such as epitaxial silicon, epitaxial germanium, or epitaxial silicon-germanium. No semiconductor layer is formed on non-silicon features, such as sidewall spacers **252**, **254** and dielectric isolation regions **268**, **270**. Semiconductor layer **256a-256c** has a thickness T₂₅₆ of, for example, approximately 100-500 Å.

Semiconductor layer **256a-256c** has a low resistivity of, e.g., 0.001 ohm-cm, that facilitates the formation of low-resistance contacts. To achieve this low resistivity, semiconductor layer **256a-256c** is, for example, epitaxial silicon doped with, for example, arsenic to a concentration of 1×10²⁰ atoms/cm³. Semiconductor layer **256a-256c** may be doped in

situ, during deposition. In alternative embodiments, semiconductor layer **256a-256c** may be doped after deposition by ion implantation or by gas-, plasma- or solid-source diffusion. In some embodiments, the doping of semiconductor layer **256a-256c** and the formation of source **262** and drain **266** are performed simultaneously. Portions of semiconductor layer **256a**, **256c** disposed over source **262** and drain **266** may have top surfaces substantially free of facets. In an embodiment, portions of source **262**, drain **266**, and/or gate **259** may be etched away to define recess prior to deposition of semiconductor layer **256a-256c**, and semiconductor layer **256a-256c** may then be deposited in the recesses thus formed.

Referring to FIG. **8C**, a metal layer **272** is formed over transistor **250**. Metal layer **272** is formed by, for example, sputter deposition. Metal layer **272** has a thickness T₂₇₂ of, e.g., 50-200 Å and includes a metal such as cobalt, titanium, tungsten, nickel, or platinum. The metal is selected to react with semiconductor layer **256a-256c** to form a low-resistance metal-semiconductor alloy when exposed to heat, as described below. The metal is also selected such that the metal-semiconductor alloy remains stable at temperatures typically required to complete transistor **250** fabrication, e.g., 400-700° C.

Referring also to FIG. **8D**, subsequent to deposition of metal layer **272**, a first rapid thermal anneal is performed, e.g., at 550° C. for 60 seconds. This heating step initiates a reaction between metal layer **272** and semiconductor layers **256a-256c**, forming a high resistivity phase of a metal-semiconductor alloy, e.g., cobalt silicide. (CoSi). Portions of metal layer **272** are removed by a wet etch, such as sulfuric acid and hydrogen peroxide. In an alternative embodiment, the wet etch may be ammonium hydroxide, peroxide, and water. This wet etch removes portions of metal layer **272** disposed over dielectric material, such as over first and second sidewall spacers **252**, **254** and isolation regions **268**, **270**. Portions **274** of metal layer **272** disposed over semiconductor layer **256a-256c** that have reacted to form the metal-semiconductor alloy remain in place after the anneal and wet etch.

Referring to FIG. **8E**, SSOI substrate **100**, including transistor **250**, is subjected to a second heat treatment. For example, in an embodiment in which metal layer **272** includes cobalt, SSOI substrate **100** undergoes a rapid thermal anneal at 800° C. for 60 seconds in a nitrogen ambient. This heating step initiates a reaction in the metal-semiconductor alloy layer which substantially lowers its resistivity, to form a substantially homogeneous contact layer **276a-276c**. Contact layer **276a-276c** includes a metal-semiconductor alloy, e.g., a metal silicide such as a low resistivity phase of cobalt silicide (CoSi₂). Contact layer **276a-276c** has a thickness T₂₇₆ of, for example, 400 Å. Contact layer **276a-276c** has a low sheet resistance, e.g., less than about 10 Ω/□, and enables a good quality contact to be made to source **262** and drain **266**, as well as to gate **259**.

In some embodiments, during formation, contact layer **276a-276c** may consume substantially all of semiconductor layer **256a-256c**. A bottommost boundary **278a** of contact layer **276a**, therefore, shares an interface **280a** with strained layer **18** in source **262**, and a bottommost boundary **278c** of contact layer **276c**, therefore, shares an interface **280c** with strained layer **18** in drain **266**. A bottommost boundary **278b** of contact layer **276b** shares an interface **280b** with gate **259**.

In other embodiments, contact layer portions **276a**, **276c**, disposed over source **262** and drain **266**, may extend into strained layer **18**. Interfaces **280a**, **280c** between contact layer **276a**, **276c** and strained layer **18** are then disposed within source **262** and drain **266**, respectively, above bottommost boundaries **282a**, **282c** of strained layer **18**. Interfaces **280a**,

13

280c have a low contact resistivity, e.g., less than approximately $5 \times 10^{-7} \Omega\text{-cm}^2$. In certain other embodiments, during formation, contact layer 276a-276c may not consume all of semiconductor layer 256a-256c (see FIG. 8D). A bottommost boundary 278a of contact layer 276a, therefore, shares an interface with semiconductor layer 256a over source 262, and a bottommost boundary 278c of contact layer 276c, therefore, shares an interface with semiconductor layer 256c over drain 266.

Because strained layer 18 includes a strained material, carrier mobilities in strained layer 18 are enhanced, facilitating lower sheet resistances. This strain also results in a reduced energy bandgap, thereby lowering the contact resistivity between the metal-semiconductor alloy and the strained layer.

In alternative embodiments, an SSOI structure may include, instead of a single strained layer, a plurality of semiconductor layers disposed on an insulator layer. For example, referring to FIG. 9, epitaxial wafer 300 includes strained layer 18, relaxed layer 16, graded layer 14, and substrate 12. In addition, a semiconductor layer 310 is disposed over strained layer 18. Strained layer 18 may be tensilely strained and semiconductor layer 310 may be compressively strained. In an alternative embodiment, strained layer 18 may be compressively strained and semiconductor layer 310 may be tensilely strained. Strain may be induced by lattice mismatch with respect to an adjacent layer, as described above, or mechanically. For example, strain may be induced by the deposition of overlayers, such as Si_3N_4 . In another embodiment, semiconductor layer 310 is relaxed. Semiconductor layer 310 includes a semiconductor material, such as at least one of a group II, a group III, a group IV, a group V, and a group VI element. Epitaxial wafer 300 is processed in a manner analogous to the processing of epitaxial wafer 8, as described with reference to FIGS. 1-7.

Referring also to FIG. 10, processing of epitaxial wafer 300 results in the formation of SSOI substrate 350, having strained layer 18 disposed over semiconductor layer 310. Semiconductor layer 310 is bonded to dielectric layer 52, disposed over substrate 54. As noted above with reference to FIG. 9, strained layer 18 may be tensilely strained and semiconductor layer 310 may be compressively strained. Alternatively, strained layer 18 may be compressively strained and semiconductor layer 310 may be tensilely strained. In some embodiments, semiconductor layer 310 may be relaxed.

Referring to FIG. 11, in some embodiments, a thin strained layer 84 may be grown between strained layer 18 and relaxed layer 16 to act as an etch stop during etching, such as wet etching. In an embodiment in which strained layer 18 includes Si and relaxed layer 16 includes $\text{Si}_{1-y}\text{Ge}_y$, thin strained layer 84 may include $\text{Si}_{1-x}\text{Ge}_x$, with a higher Ge content (x) than the Ge content (y) of relaxed layer 16, and hence be compressively strained. For example, if the composition of the relaxed layer 16 is 20% Ge ($\text{Si}_{0.80}\text{Ge}_{0.20}$), thin strained layer 84 may contain 40% Ge ($\text{Si}_{0.60}\text{Ge}_{0.40}$) to provide a more robust etch stop. In other embodiments, a second strained layer, such as thin strained layer 84 with higher Ge content than relaxed layer 16, may act as a preferential cleave plane in the hydrogen exfoliation/cleaving procedure described above.

In an alternative embodiment, thin strained layer 84 may contain $\text{Si}_{1-x}\text{Ge}_x$ with lower Ge content than relaxed layer 16. In this embodiment, thin strained layer 84 may act as a diffusion barrier during the wet oxidation process. For example, if the composition of relaxed layer 16 is 20% Ge ($\text{Si}_{0.80}\text{Ge}_{0.20}$), thin strained layer 84 may contain 10% Ge ($\text{Si}_{0.90}\text{Ge}_{0.10}$) to provide a barrier to Ge diffusion from the

14

higher Ge content relaxed layer 16 during the oxidation process. In another embodiment, thin strained layer 84 may be replaced with a thin graded $\text{Si}_{1-z}\text{Ge}_z$ layer in which the Ge composition (z) of the graded layer is decreased from relaxed layer 16 to the strained layer 18.

Referring again to FIG. 7, in some embodiments, a small amount, e.g., approximately 20-100 Å, of strained layer 18 may be removed at an interface 105 between strained layer 18 and relaxed layer portion 80. This may be achieved by overetching after relaxed layer portion 80 is removed. Alternatively, this removal of strained layer 18 may be performed by a standard microelectronics clean step such as an RCA SC1, i.e., hydrogen peroxide, ammonium hydroxide, and water ($\text{H}_2\text{O}_2 + \text{NH}_4\text{OH} + \text{H}_2\text{O}$), which at, e.g., 80° C. may remove silicon. This silicon removal may remove any misfit dislocations that formed at the original strained layer 18/relaxed layer 80 interface 105 if strained layer 18 was grown above the critical thickness. The critical thickness may be defined as the thickness of strained layer 18 beyond which it becomes energetically favorable for the strain in the layer to partially relax via the introduction of misfit dislocations at interface 105 between strained layer 18 and relaxed layer 16. Thus, the method illustrated in FIGS. 1-7 provides a technique for obtaining strained layers above a critical thickness without misfit dislocations that may compromise the performance of deeply scaled MOSFET devices.

Referring to FIG. 12, in some embodiments, handle wafer 50 may have a structure other than a dielectric layer 52 disposed over a semiconductor substrate 54. For example, a bulk relaxed substrate 400 may comprise a bulk material 410 such as a semiconductor material, e.g., bulk silicon. Alternatively, bulk material 410 may be a bulk dielectric material, such as Al_2O_3 (e.g., alumina or sapphire) or SiO_2 (e.g., quartz). Epitaxial wafer 8 may then be bonded to handle wafer 400 (as described above with reference to FIGS. 1-6), with strained layer 18 being bonded to the bulk material 410 comprising handle wafer 400. In embodiments in which bulk material 410 is a semiconductor, to facilitate this semiconductor-semiconductor bond, a hydrophobic clean may be performed, such as an HF dip after an RCA SC1 clean.

Referring to FIG. 13, after bonding and further processing (as described above), a strained-semiconductor-on-semiconductor (SSOS) substrate 420 is formed, having strained layer 18 disposed in contact with relaxed substrate 400. The strain of strained layer 18 is not induced by underlying relaxed substrate 400, and is independent of any lattice mismatch between strained layer 18 and relaxed substrate 400. In an embodiment, strained layer 18 and relaxed substrate 400 include the same semiconductor material, e.g., silicon. Relaxed substrate 400 may have a lattice constant equal to a lattice constant of strained layer 18 in the absence of strain. Strained layer 18 may have a strain greater than approximately 1×10^{-3} . Strained layer 18 may have been formed by epitaxy, and may have a thickness T_5 of between approximately 20 Å-1000 Å, with a thickness uniformity of better than approximately $\pm 10\%$. In an embodiment, strained layer 18 may have a thickness uniformity of better than approximately $\pm 5\%$. Surface 92 of strained layer 18 may have a surface roughness of less than 20 Å.

Referring to FIG. 14, in an embodiment, after fabrication of the SSOI structure 100 including semiconductor substrate 54 and dielectric layer 52, it may be favorable to selectively relax the strain in at least a portion of strained layer 18. This could be accomplished by introducing a plurality of ions by, e.g., ion implantation after a photolithography step in which at least a portion of the structure is masked by, for example, a photoresist feature 500. Ion implantation parameters may be,

15

for example, an implant of Si ions at a dose of 1×10^{15} - 1×10^{17} ions/cm², at an energy of 5-75 keV. After ion implantation, a relaxed portion **502** of strained layer **18** is relaxed, while a strained portion **504** of strained layer **18** remains strained.

Referring to FIGS. **15A-15E**, SSOI structure **100** (see FIG. **6**) may be formed by the use of a porous semiconductor substrate. Referring to FIG. **15A**, substrate **12** may be formed of a semiconductor, such as Si, Ge, or SiGe. A plurality of pores **1514**, i.e., microvoids, are formed to define a porous layer **1516** in a portion of substrate **12**. Pores **1514** may have a median diameter of 5-10 nm and a pitch of 10-50 nm. Porous layer **1516** may have a porosity of 10-50% and may extend a depth of d_{15} into substrate **12** of approximately 1-5 μm .

Referring to FIG. **15B**, pores **1514** may be formed by, for example, submerging substrate **12** into a vessel **1517** containing an electrolyte **1518**, such as hydrofluoric acid (HF), possibly mixed with ethanol, with a cathode **1520** and an anode **1522** disposed in the electrolyte **1518**. A back surface chucking holder **1519a** with a vacuum pad **1519b** may hold substrate **12** while it is submerged in vessel **1517**. A current may be generated between cathode **1520** and anode **1522**, through substrate **12**, resulting in the electrochemical etching of substrate **12**, thereby forming pores **1514** at a top surface **1524** of substrate **12**. In an embodiment, prior to the formation of pores **1514**, substrate **12** may be planarized, e.g., by CMP.

Referring to FIG. **15C**, after the formation of pores **1514**, a plurality of layers **10** may be formed over porous top surface **1524** of substrate **12**, as described with reference to FIG. **1A**. Layers **10** may include, for example, graded buffer layer **14**, relaxed layer **16**, and strained layer **18**. Pores **1514** define cleave plane **20** in porous layer **1516** of substrate **12**.

Referring to FIG. **15D**, substrate **12** with layers **10** is bonded to handle wafer **50**, including semiconductor substrate **54** and dielectric layer **52**, as described with reference to FIG. **3**. Prior to bonding, a dielectric layer may be formed on a top surface of layers **10** to facilitate the bonding process and to serve as an insulator layer in the final substrate structure.

Referring to FIG. **15E** as well as to FIG. **15D**, a split is induced at cleave plane **20** by, for example, cleaving porous layer **1516** by a water or an air jet. The split results in the formation of two separate wafers **1570**, **1572**. One of these wafers (**1572**) has graded layer **14** and relaxed layer **16** (see FIG. **15C**) disposed over strained layer **18**, with a first portion **1580** of substrate **12** disposed over graded layer **14**. First portion **1580** of substrate **12** may be just trace amounts of material surrounding pores **1514**. Strained layer **18** is in contact with dielectric layer **52** on semiconductor substrate **54**. The other of these wafers (**1570**) includes a second portion **1582** of substrate **12**, including the bulk of substrate **12** with perhaps trace amounts of material surrounding pores **1514**.

Referring to FIG. **6** as well as to FIG. **15E**, first portion **1580** of substrate **12** is removed from graded layer **14** by a wet chemical cleaning process utilizing, for example a mixture of hydrogen peroxide (H_2O_2) and HF. Graded layer **14** and relaxed layer **16** are removed in any one of the methods described for the removal of relaxed layer portion **80** with reference to FIGS. **4** and **5**. Removal of graded and relaxed layers **14**, **16** results in the formation of SSOI substrate **100**.

Referring to FIG. **16A**, SSOI substrate **100** (see FIG. **6**) may also be formed by the use of porous intermediate layers. For example, plurality of layers **10** may be formed over substrate **12**, layers **10** including graded layer **14**, relaxed layer **16**, and strained layer **18** (see FIG. **1A**). Prior to the formation of strained layer **18**, a plurality of pores **1614** may be formed in a top portion of relaxed layer **16**, thereby defining a porous layer **1616** in a top portion **1617** of relaxed layer **16**. Pores

16

1614 may be formed by the methods described above with reference to the formation of pores **1514** in FIG. **15B**. Porous layer **1616** may have a thickness T_{16} of, e.g., 1-5 μm . Strained layer **18** may then be formed directly over porous layer **1616**. Pores **1614** define cleave plane **20** in porous layer **1616**.

Referring to FIG. **16B**, in an alternative embodiment, after the formation of porous layer **1616** in a portion of relaxed layer **16**, a second relaxed layer **1620** may be formed over relaxed layer **16** including porous layer **1616**. Second relaxed layer **1620** may include the same material from which relaxed layer **16** is formed, e.g., uniform $\text{Si}_{1-x}\text{Ge}_x$, having a Ge content of, for example, 10-80% (i.e., $x=0.1-0.8$) and having a thickness T_{17} of, e.g., 5-100 nm. In some embodiments, $\text{Si}_{1-x}\text{Ge}_x$ may include $\text{Si}_{0.70}\text{Ge}_{0.30}$ and T_{17} may be approximately 50 nm. Second relaxed layer **1620** may be fully relaxed, as determined by triple axis X-ray diffraction, and may have a threading dislocation density of $<1 \times 10^6/\text{cm}^2$, as determined by etch pit density (EPD) analysis. Strained layer **18** may be formed over second relaxed layer **1620**. Pores **1614** define cleave plane **20** in porous layer **1616**.

Referring to FIG. **16C**, substrate **12** with layers **10** is bonded to handle wafer **50**, including semiconductor substrate **54** and dielectric layer **52**, as described with reference to FIG. **3**.

Referring to FIG. **16D** as well as to FIG. **16C**, a split is induced at cleave plane **20** by, for example, cleaving porous layer **1616** by a water or an air jet. The split results in the formation of two separate wafers **1670**, **1672**. One of these wafers (**1670**) has top portion **1617** of relaxed layer **16** (see FIG. **16A**) disposed over strained layer **18**. Strained layer **18** is in contact with dielectric layer **52** on semiconductor substrate **54**. The other of these wafers (**1672**) includes the substrate **12**, graded layer **14**, and a bottom portion **1674** of relaxed layer **16**.

Referring to FIG. **6** as well as to FIG. **16D**, top portion **1617** of relaxed layer **16** is removed in any one of the methods described for the removal of relaxed layer portion **80** with reference to FIGS. **4** and **5**. Removal of top portion **1617** of relaxed layer **16** results in the formation of SSOI substrate **100**.

The bonding of strained silicon layer **18** to dielectric layer **52** has been experimentally demonstrated. For example, strained layer **18** having a thickness of 54 nanometers (nm) along with ~ 350 nm of $\text{Si}_{0.70}\text{Ge}_{0.30}$ have been transferred by hydrogen exfoliation to Si handle wafer **50** having dielectric layer **52** formed from thermal SiO_2 with a thickness of approximately 100 nm. The implant conditions were a dose of 4×10^{16} ions/cm³ of H_2^+ at 75 keV. The anneal procedure was 1 hour at 550° C. to split the SiGe layer, followed by a 1 hour, 800° C. strengthening anneal. The integrity of strained Si layer **18** and good bonding to dielectric layer **52** after layer transfer and anneal were confirmed with cross-sectional transmission electron microscopy (XTEM). An SSOI structure **100** was characterized by XTEM and analyzed via Raman spectroscopy to determine the strain level of the transferred strained Si layer **18**. An XTEM image of the transferred intermediate SiGe/strained Si/ SiO_2 structure showed transfer of the 54 nm strained Si layer **18** and ~ 350 nm of the $\text{Si}_{0.70}\text{Ge}_{0.30}$ relaxed layer **16**. Strained Si layer **18** had a good integrity and bonded well to SiO_2 **54** layer after the annealing process.

XTEM micrographs confirmed the complete removal of relaxed SiGe layer **16** after oxidation and HF etching. The final structure includes strained Si layer **18** having a thickness of 49 nm on dielectric layer **52** including SiO_2 and having a thickness of 100 nm.

Raman spectroscopy data enabled a comparison of the bonded and cleaved structure before and after SiGe layer **16** removal. Based on peak positions the composition of the relaxed SiGe layer and strain in the Si layer may be calculated. See, for example, J. C. Tsang, et al., J. Appl. Phys. 75 (12) p. 8098 (1994), incorporated herein by reference. The fabricated SSOI structure **100** had a clear strained Si peak visible at ~511/cm. Thus, the SSOI structure **100** maintained greater than 1% tensile strain in the absence of the relaxed SiGe layer **16**. In addition, the absence of Ge-Ge, Si—Ge, and Si-Si relaxed SiGe Raman peaks in the SSOI structure confirmed the complete removal of SiGe layer **16**.

In addition, the thermal stability of the strained Si layer was evaluated after a 3 minute 1000° C. rapid thermal anneal (RTA) to simulate an aggregate thermal budget of a CMOS process. A Raman spectroscopy comparison was made of SSOI structure **100** as processed and after the RTA step. A scan of the as-bonded and cleaved sample prior to SiGe layer removal was used for comparison. Throughout the SSOI structure **100** fabrication process and subsequent anneal, the strained Si peak was visible and the peak position did not shift. Thus, the strain in SSOI structure **100** was stable and was not diminished by thermal processing. Furthermore, bubbles or flaking of the strained Si surface **18** were not observed by Nomarski optical microscopy after the RTA, indicating good mechanical stability of SSOI structure **100**.

The invention may be embodied in other specific forms without departing from the spirit or essential characteristics thereof. The foregoing embodiments are therefore to be considered in all respects illustrative rather than limiting on the invention described herein. Scope of the invention is thus indicated by the appended claims rather than by the foregoing description, and all changes which come within the meaning and range of equivalency of the claims are intended to be embraced therein.

What is claimed is:

1. A structure comprising:
 - a semiconductor substrate having a dielectric layer disposed thereon and in contact therewith;
 - a strained semiconductor layer disposed in contact with the dielectric layer, such that the dielectric layer is disposed between the strained semiconductor layer and the substrate; and
 - a transistor including
 - a gate disposed above the strained semiconductor layer, the gate comprising at least one of a doped semiconductor, a metal, or a metallic compound,
 - a source region disposed proximate the gate and above the dielectric layer,
 - a drain region disposed proximate the gate and above the dielectric layer, and
 - a contact layer portion comprising a metal-semiconductor alloy disposed over a second semiconductor layer comprising germanium, the contact layer portion being disposed over at least one of the source and the drain regions.
2. The structure of claim 1, wherein the gate comprises a doped semiconductor comprising at least one of polycrystalline silicon or polycrystalline silicon-germanium.
3. The structure of claim 1, wherein the gate consists essentially of a metal comprising at least one of titanium, tungsten, molybdenum, tantalum, nickel, or iridium.
4. The structure of claim 1, wherein the gate consists essentially of a metal compound comprising at least one of titanium

nitride, titanium silicon nitride, tungsten nitride, tantalum nitride, tantalum silicide, nickel silicide, or iridium oxide.

5. The structure of claim 1, wherein a bottommost boundary of the contact layer portion is disposed above a bottommost boundary of the second semiconductor layer.

6. The structure of claim 1, further comprising:

- an overlayer disposed above the strained semiconductor layer,
- wherein the overlayer induces at least a portion of the strain in the strained semiconductor layer.

7. The structure of claim 6, wherein the overlayer comprises silicon nitride.

8. The structure of claim 1, wherein the strained semiconductor layer comprises a first semiconducting material, the second semiconductor layer comprises a second semiconducting material, and the second semiconducting material is different from the first semiconducting material.

9. The structure of claim 1, wherein the second semiconductor layer is disposed over and in contact with the strained semiconductor layer.

10. The structure of claim 1, further comprising a gate dielectric layer disposed beneath the gate and disposed over and in contact with the strained semiconductor layer.

11. The structure of claim 1, wherein the second semiconductor layer comprises an epitaxial layer.

12. The structure of claim 1, wherein the second semiconductor layer comprises SiGe.

13. The structure of claim 1, wherein a composition of the strained semiconductor layer is approximately constant through a thickness of the strained semiconductor layer.

14. A structure comprising:

- a semiconductor substrate having a dielectric layer disposed thereon and in contact therewith;
- a strained semiconductor layer disposed in contact with the dielectric layer, such that the dielectric layer is disposed between the strained semiconductor layer and the substrate; and

a transistor including

- a gate disposed above the strained semiconductor layer, the gate comprising a material selected from the group consisting of a doped semiconductor, a metal, and a metallic compound,
- a source region disposed proximate the gate and above the dielectric layer,
- a drain region disposed proximate the gate and above the dielectric layer, and
- a contact layer portion disposed over at least one of the source and the drain regions,

wherein the contact layer portion comprises a metal-semiconductor alloy comprising germanium, the at least one of the source and drain regions comprises a first semiconducting material composition, the metal-semiconductor alloy comprises a second semiconducting material composition, and the first semiconducting material composition is different from the second semiconducting material composition.

15. The structure of claim 14, further comprising an overlayer disposed above the strained semiconductor layer that induces at least a portion of the strain in the strained semiconductor layer.

16. The structure of claim 15, wherein the overlayer comprises silicon nitride.

17. The structure of claim 14, wherein the doped semiconductor comprises a material selected from the group consisting of polycrystalline silicon and polycrystalline silicon-germanium.

19

18. The structure of claim 14, wherein the metal comprises a material selected from the group consisting of titanium, tungsten, molybdenum, tantalum, nickel, and iridium.

19. The structure of claim 14, wherein the metal compound comprises a material selected from the group consisting of titanium nitride, titanium silicon nitride, tungsten nitride, tantalum nitride, tantalum silicide, nickel silicide, and iridium oxide.

20. The structure of claim 14, wherein the first semiconducting material composition comprises germanium and the second semiconducting material composition comprises silicon.

21. The structure of claim 14, further comprising a gate dielectric layer disposed beneath the gate and disposed over and in contact with the strained semiconductor layer.

22. The structure of claim 14, wherein the contact layer portion is disposed over and in contact with the strained semiconductor layer.

23. A structure comprising:

a semiconductor substrate having a dielectric layer disposed thereon and in contact therewith;

a strained semiconductor layer disposed in contact with the dielectric layer, such that the dielectric layer is disposed between the strained semiconductor layer and the substrate; and

a transistor including

a gate disposed above the strained semiconductor layer, the gate comprising at least one of a doped semiconductor, a metal, or a metallic compound,

a source region disposed proximate the gate and above the dielectric layer,

a drain region disposed proximate the gate and above the dielectric layer, and

a contact layer portion comprising a metal-semiconductor alloy disposed over a second semiconductor layer, the contact layer portion being disposed over at least one of the source and the drain regions,

wherein at least one of the source and drain regions includes a recess, and a portion of the second semiconductor layer is deposited within the recess.

24. A structure comprising:

a semiconductor substrate having a dielectric layer disposed thereon and in contact therewith;

a strained semiconductor layer disposed in contact with the dielectric layer, such that the dielectric layer is disposed between the strained semiconductor layer and the substrate; and

20

a transistor including

a gate disposed above the strained semiconductor layer, the gate comprising a material selected from the group consisting of a doped semiconductor, a metal, and a metallic compound,

a source region disposed proximate the gate and above the dielectric layer,

a drain region disposed proximate the gate and above the dielectric layer, and

a contact layer portion comprising a metal-semiconductor alloy disposed over at least one of the source and the drain regions,

wherein the at least one of the source and drain regions comprises a first semiconducting material composition comprising silicon, the metal-semiconductor alloy comprises a second semiconducting material composition comprising germanium, and the first semiconducting material composition is different from the second semiconducting material composition.

25. A structure comprising:

a semiconductor substrate having a dielectric layer disposed thereon and in contact therewith;

a strained semiconductor layer disposed in contact with the dielectric layer, such that the dielectric layer is disposed between the strained semiconductor layer and the substrate; and

a transistor including

a gate disposed above the strained semiconductor layer, the gate comprising at least one of a doped semiconductor, a metal, or a metallic compound,

a source region disposed proximate the gate and above the dielectric layer,

a drain region disposed proximate the gate and above the dielectric layer,

a contact layer portion comprising a metal-semiconductor alloy disposed over a second semiconductor layer, the contact layer portion being disposed over at least one of the source and the drain regions, and

a gate dielectric layer disposed beneath the gate and disposed over and in contact with the strained semiconductor layer,

wherein a distance between an interface between the gate dielectric layer and the strained semiconductor layer and an interface between the substrate and the dielectric layer is less than a distance between an interface between the contact layer portion and the second semiconductor layer and an interface between the substrate and the dielectric layer.

* * * * *