



US007418432B2

(12) **United States Patent**
Calise et al.

(10) **Patent No.:** **US 7,418,432 B2**
(45) **Date of Patent:** ***Aug. 26, 2008**

(54) **ADAPTIVE CONTROL SYSTEM HAVING DIRECT OUTPUT FEEDBACK AND RELATED APPARATUSES AND METHODS**

(75) Inventors: **Anthony J. Calise**, Atlanta, GA (US);
Naira Hovakimyan, Smyrna, GA (US);
Moshe Idan, Haifa (IL)

(73) Assignee: **Georgia Tech Research Corporation**,
Atlanta, GA (US)

(*) Notice: Subject to any disclaimer, the term of this patent is extended or adjusted under 35 U.S.C. 154(b) by 0 days.

This patent is subject to a terminal disclaimer.

(21) Appl. No.: **11/105,826**

(22) Filed: **Apr. 12, 2005**

(65) **Prior Publication Data**

US 2005/0182499 A1 Aug. 18, 2005

Related U.S. Application Data

(63) Continuation of application No. 09/865,659, filed on May 25, 2001, now Pat. No. 6,904,422.

(60) Provisional application No. 60/208,101, filed on May 27, 2000.

(51) **Int. Cl.**

G05B 13/02 (2006.01)

G06E 1/00 (2006.01)

G06E 3/00 (2006.01)

G06F 15/18 (2006.01)

G06G 7/00 (2006.01)

(52) **U.S. Cl.** **706/23**

(58) **Field of Classification Search** **706/28**,
706/22-23, **14-15**; **700/29**, **36**, **37**, **45**, **48**

See application file for complete search history.

(56) **References Cited**

U.S. PATENT DOCUMENTS

5,038,269 A *	8/1991	Grimble et al.	700/52
5,049,796 A	9/1991	Seraji	
5,121,467 A	6/1992	Skeirik	
5,142,612 A	8/1992	Skeirik	
5,159,990 A *	11/1992	Abe et al.	180/197
5,167,009 A	11/1992	Skeirik	

(Continued)

OTHER PUBLICATIONS

Model reference adaptive control of abstract nonlinear distributed parameter systems Demetriou, M.A.; Rosen, I.G.; Reich, S.; American Control Conference, 1994 vol. 3, Jun. 29-Jul. 1, 1994 pp. 3400-3401 vol. 3.*

(Continued)

Primary Examiner—Michael B Holmes

(74) *Attorney, Agent, or Firm*—Patents and Licensing LLC; Daniel W. Juffernbruch

(57) **ABSTRACT**

An adaptive control system (ACS) uses direct output feedback to control a plant. The ACS uses direct adaptive output feedback control developed for highly uncertain nonlinear systems, that does not rely on state estimation. The approach is also applicable to systems of unknown, but bounded dimension, whose output has known, but otherwise arbitrary relative degree. This includes systems with both parameter uncertainty and unmodeled dynamics. The result is achieved by extending the universal function approximation property of linearly parameterized neural networks to model unknown system dynamics from input/output data. The network weight adaptation rule is derived from Lyapunov stability analysis, and guarantees that the adapted weight errors and the tracking error are bounded.

20 Claims, 10 Drawing Sheets

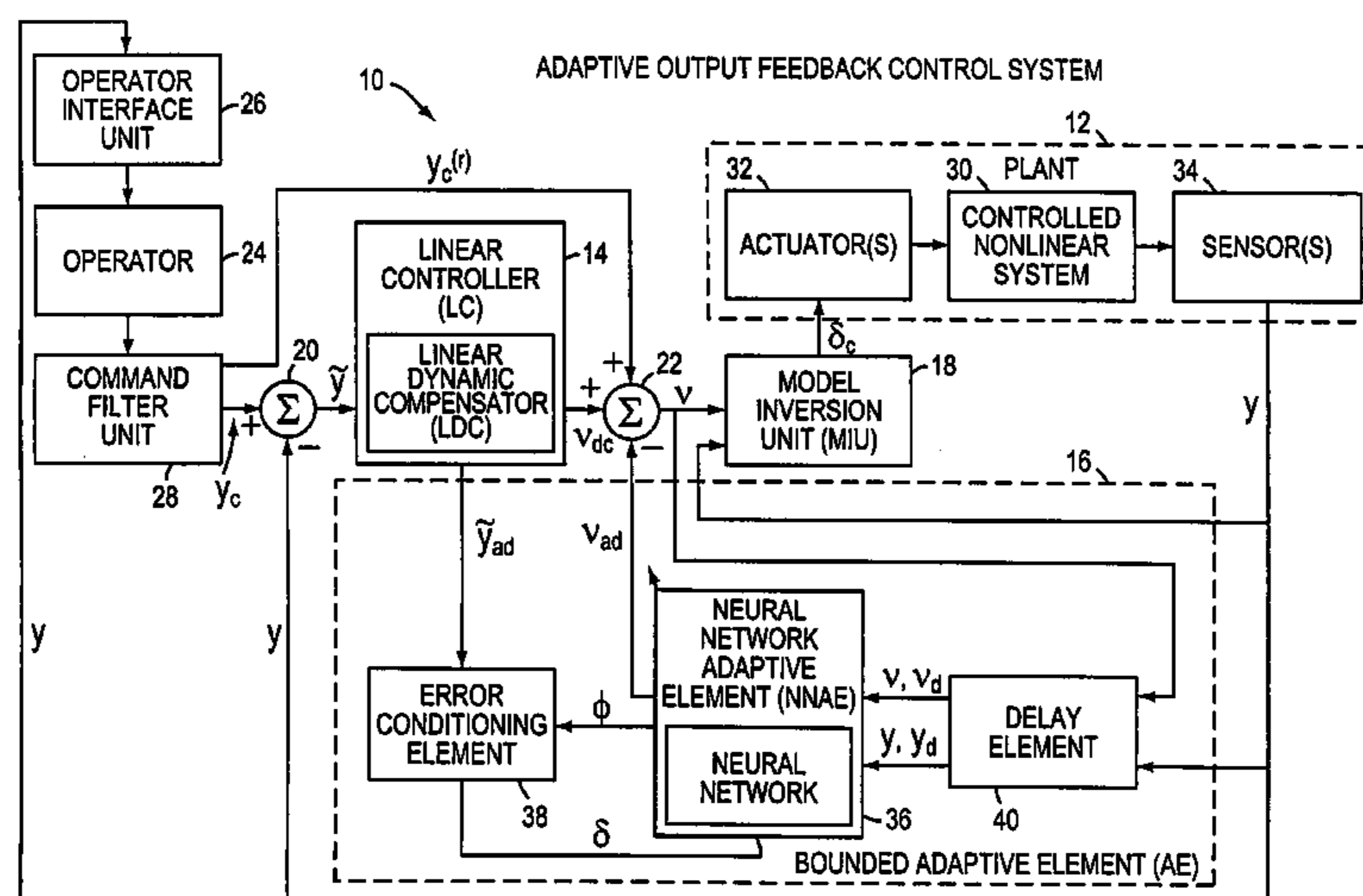

U.S. PATENT DOCUMENTS

5,197,114	A	3/1993	Skeirik	
5,224,203	A	6/1993	Skeirik	
5,249,117	A *	9/1993	Greenough et al.	700/30
5,268,834	A *	12/1993	Sanner et al.	700/31
5,311,421	A *	5/1994	Nomura et al.	700/37
5,367,612	A	11/1994	Bozich et al.	
5,426,720	A	6/1995	Bozich et al.	
5,469,087	A *	11/1995	Eatwell	327/40
5,493,631	A *	2/1996	Huang et al.	706/23
5,558,076	A *	9/1996	Maki et al.	123/687
5,586,221	A *	12/1996	Isik et al.	706/23
5,680,513	A	10/1997	Hyland et al.	
5,719,480	A *	2/1998	Bock et al.	318/568.11
5,796,920	A	8/1998	Hyland	
5,796,922	A *	8/1998	Smith	706/23
5,943,660	A	8/1999	Yesildirek et al.	
5,959,861	A	9/1999	Kaneko	
6,055,524	A *	4/2000	Cheng	706/23
6,064,997	A	5/2000	Jagannathan et al.	
6,085,183	A	7/2000	Horn et al.	
6,092,919	A *	7/2000	Calise et al.	700/45
6,094,601	A *	7/2000	Popovich	700/28
6,169,981	B1 *	1/2001	Werbos	706/23
6,201,872	B1 *	3/2001	Hersh et al.	381/71.5
6,241,435	B1 *	6/2001	Huang et al.	409/141
6,332,105	B1 *	12/2001	Calise et al.	701/3
6,351,740	B1	2/2002	Rabinowitz	
6,503,649	B1 *	1/2003	Czajkowski et al.	429/23
6,532,454	B1	3/2003	Werbos	
6,581,048	B1 *	6/2003	Werbos	706/23
6,611,823	B1 *	8/2003	Selmic et al.	706/14
6,618,631	B1 *	9/2003	Johnson et al.	700/28
6,618,646	B1 *	9/2003	Dyer	700/279
6,757,570	B1 *	6/2004	Calise et al.	700/45
6,780,322	B1 *	8/2004	Bissler et al.	210/637
6,883,373	B2 *	4/2005	Dyer	73/462
6,904,422	B2 *	6/2005	Calise et al.	706/23
7,155,973	B2 *	1/2007	Dyer	73/462
7,177,710	B2 *	2/2007	Calise et al.	700/28
7,218,973	B2 *	5/2007	Johnson et al.	700/28
7,261,962	B1 *	8/2007	Czajkowski et al.	429/23
7,277,764	B2 *	10/2007	Hovakimyan et al.	700/28

OTHER PUBLICATIONS

Robust stabilization and robust performing using model reference control and modeling error compensation Sun, J.; Olbrot, A.W.; Polis, M.P.; Automatic Control, IEEE Transactions on vol. 39, Issue 3, Mar. 1994 pp. 630-635.*

A new implementation for simplified adaptive control Su, W.; Sobel, K.M.; Intelligent Control, 1990. Proceedings., 5th IEEE International Symposium on Sep. 5-7, 1990 pp. 748-753 vol. 2.*

Adaptive output feedback control for MIMO plants with unknown orders Mizumoto, I.; Takahashi, M.; Iwai, Z.; Decision and Control, 1996., Proceedings of the 35th IEEE vol. 1, Dec. 11-13, 1996 pp. 829-836 vol. 1.*

The minimal time detection algorithm of changes in control parameters and its application to flight systems Sungwan Kim; Decision and Control, 1994., Proceedings of the 33rd IEEE Conference on vol. 4, Dec. 14-16, 1994 pp. 3318-3323 vol. 4 Digital Object Identifier 10.1109/CDC.1994.411648.*

Chen et al. "Adaptive Control of a Class of Nonlinear Systems Using Neural Networks," Proceedings of the 34th Conference On Decision And Control, Dec. 1995.

McFarland et al., "Robustness Analysis for a Neural Network Based Adaptive Control Scheme," Proceedings of the American Control Conference, Jun. 1995.

Calise et al., "Design of Optimal Feedback Compensations in Two-Time Scale Systems," IEEE Transactions on Automatic Control, Apr. 1990.

Moerder et al., "Near-Optimal Output Feedback Regulation of III-Conditioned Linear Systems," IEEE Transactions on Automatic Control, May 1988.

Rysdyk et al., "Robust Adaptive Linear Flight Control Applications Using Neural Networks," Proceedings of the American Control Conference, Jun. 1999.

McFarland et al., "Robust Adaptive Control Using Single-Hidden-Layer Feedforward Neural Networks," Proceedings of the American Control Conference, Jun. 1999.

Calise et al., "An SPR Approach For Adaptive Output Feedback Control With Neural Networks," Proceedings of the 40th IEEE Conference on Decision And Control, Dec. 2001.

Brdys et al., "Recurrent Networks For Nonlinear Adaptive Control," IEE Proceedings-Control Theory And Applications, Mar. 1998.

Widrow et al., "Adaptive Inverse Control Based on Linear and Non-linear Adaptive Filtering," Proceedings of the International Workshop on Neural Networks For Identification, Control, Robotics and Signal/Image Processing, Aug. 1996.

Chen et al., "Adaptive Control of a Class of Nonlinear-Discrete-Time Systems Using Neural Networks," IEEE Transactions on Automatic Control, May 1995.

Hussain et al., "Nonlinear Control With Linearised Models and Neural Networks," 4th International Conference on Artificial Neural Networks, Jun. 1995.

Hovakimyan et al., "Dynamic Neural Networks for Output Feedback Control," Proceedings of the 38th Conference on Decision and Control, Dec. 1999.

Yamada et al., "Remarks on an Adaptive Type Self-Tuning Controller Using Neural Networks," 1991 International Conference on Industrial Electronics, Control and Instrumentation, 1991.

PCT Written Opinion, PCT/US01/17201 (PCT application related to present application) IPEA/EPO mailed Jul. 19, 2002.

PCT International Search Report, PCT/US01/17201 (PCT application related to present application), ISA/EPO Authorized Officer: Mustafa Corapci, mailed Jul. 18, 2002.

Tezcan & Basar, "Disturbance Attenuating Adaptive Controllers for Parametric Strict Feedback Nonlinear Systems with Output Measurements," Transactions of the ASME, vol. 121, pp. 48-57 (Mar. 1999).

Zhang & Peng, "Stable Neural Controller Design for Unknown Non-linear Systems Using Backstepping," Proceedings of the American Control Conf., pp. 1067-1071 (Jun. 1999).

Anthony J. Calise, et al., Adaptive output feedback control of non-linear systems using neural networks, Automatica, Mar. 7, 2001, pp. 1201-1211, Automatica 37 (2001), School of Aerospace Engineering, Georgia Institute of Technology, Atlanta, GA, USA.

Young H. Kim, et al., A Dynamic Recurrent Neural-network-based Adaptive Observer for a Class of Nonlinear Systems, Feb. 18, 1997, pp. 1539-1543, Automatica, vol. 33, No. 8, The University of Texas at Arlington, Fort Worth, Texas & The University of New Mexico, Albuquerque, NM, USA.

F.L. Lewis, Nonlinear Networks Structures for Feedback Control, Asian Journal of Control, Dec. 1999, pp. 205-228, vol. 1, No. 4.

Moshe Idan, et al., A Hierarchical Approach to Adaptive Control for Improved Flight Safety, Copyright 2001, pp. 1-11, American Institute of Aeronautics, Reston VA.

Anthony J. Calise, et al., Development of a Reconfigurable Flight Control Law for the X-36 Tailless Fighter Aircraft, AIAA 2000-3940 Copyright 2000, pp. 1-9, American Institute of Aeronautics and Astronautics, Reston, VA.

Manu Sharma, et al., Neural Networks Augmentation of Existing Linear Controllers, AIAA 2001-4163, Copyright 2001, pp. 1-9, American Institute of Aeronautics and Astronautics, Reston, VA.

Naira Hovakimyan, et al. Adaptive Output Feedback Control of a Class of Nonlinear Systems Using Neural Networks, Apr. 23, 2001, pp. 1-21, School of Aerospace Engineering, Georgia Institute of Technology, Atlanta, GA.

Ken-Ichi Funahashi, On the Approximate Realization of Continuous Mappings by Neural Networks, Sep. 14, 1988, pp. 183-192, vol. 2, Neural Networks, USA.

G. Cybenko, Approximation by Superpositions of a Sigmoidal Function, Mathematics of Control, Signals, and Systems, Feb. 17, 1989, pp. 303-315, vol. 2, Springer-Verlag New York Inc., USA.

Robert M. Sanner, et al., Gaussian Networks for Direct Adaptive Control, Nov. 1992, pp. 837-863, vol. 3, No. 6, IEEE Transactions on Neural Networks.

Sridhar Seshagiri, et al., Output Feedback Control of Nonlinear Systems Using RBF Neural Networks, Jan. 2000, pp. 69-79, vol. II, No. 1, IEEE Transactions on Neural Networks.

Jin Young Choi, et al., Observer-based Backstepping Control Using On-line Approximation, Proceedings of the American Control Conference, Chicago, Illinois, Jun. 2000, pp. 3646-3650.

Kurt Hornik, Multilayer Feedforward Networks are Universal Approximators, Neural Networks, Copyright 1989, pp. 359-366, vol. 2, USA.

J. Horn: "Feedback-Linearization using Neural Process Models" Proceedings of the 9th International Conference on Artificial Neural Networks, vol. 1, Sep. 7, 1999, pp. 37-42, XP001059447 UK, p. 37, right-hand column, line 1—p. 38, right-hand column, line 3.

Y. Zhang et al.: "Stable Neural Controller Design for Unknown Nonlinear Systems Using Backstepping" Proceedings of the 1999 American Control Conference, vol. 2, Jun. 2, 1999, pp. 1067-1071, XP010344848, USA, p. 1067, left-hand column, line 60—p. 1068, right-hand column, line 37.

K. Hassibi: "Implementation of Feedback Linearizable Controllers" Proceedings of the Spie, vol. 1709, 1992, pp. 541-547, XP001059643 USA, p. 541, line 45—p. 542, line 32.

I. Egemen et al.: "Disturbance Attenuating Adaptive Controllers for Parameteric Strict Feedback Nonlinear Systems with Output Measurements" Transactions of the Asme, vol. 121, No. 1, Mar. 1999, pp. 48-57, XP001059617 USA, p. 49, left-hand column, line—p. 50, left-hand column, line 57.

Podsiadlo P. et al.: "Output Feedback Adaptive Control of Non-Affine MIMO Systems" Motion Control Proceedings, 1993, Asia-Pacific Workshop on Advances in Singapore Jul. 15-16, 1993, New York, NY, USA, IEEE, Jul. 15, 1993, pp. 159-164, XP010113424, ISBN: 0-7803-1223-6 the whole document.

Patent Cooperation Treaty, Invitation to Pay Additional Fees with Annex to Form PCT/ISA/206 Communication Relating to the Results of the Partial International Search, Feb. 15, 2002, International Application No. PCT/US01/17201, filed May 25, 2001 by applicant Georgia Tech Research Corporation.

* cited by examiner

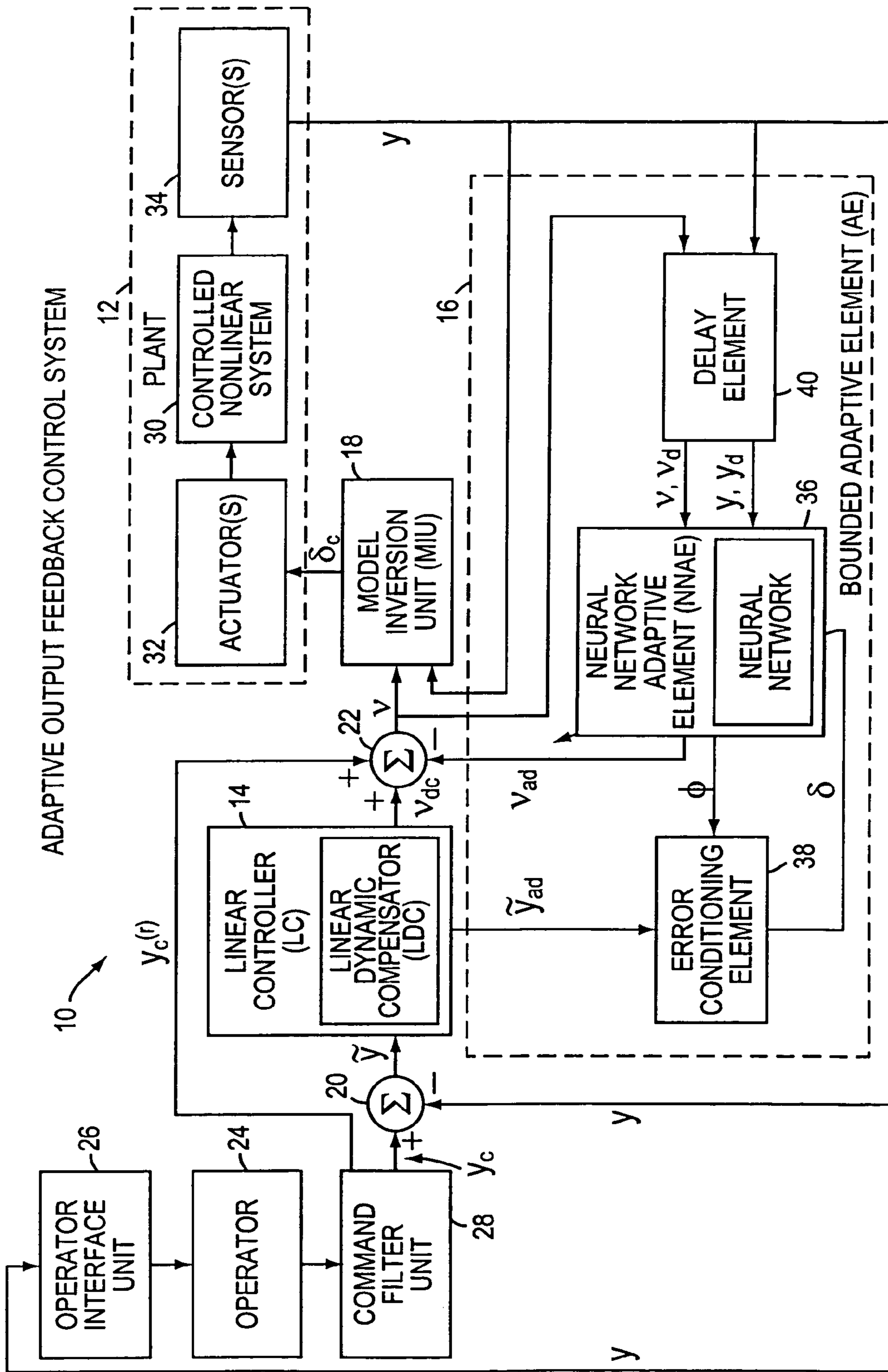

FIG. 1

TRACKING ERROR SIGNAL ANALYSIS

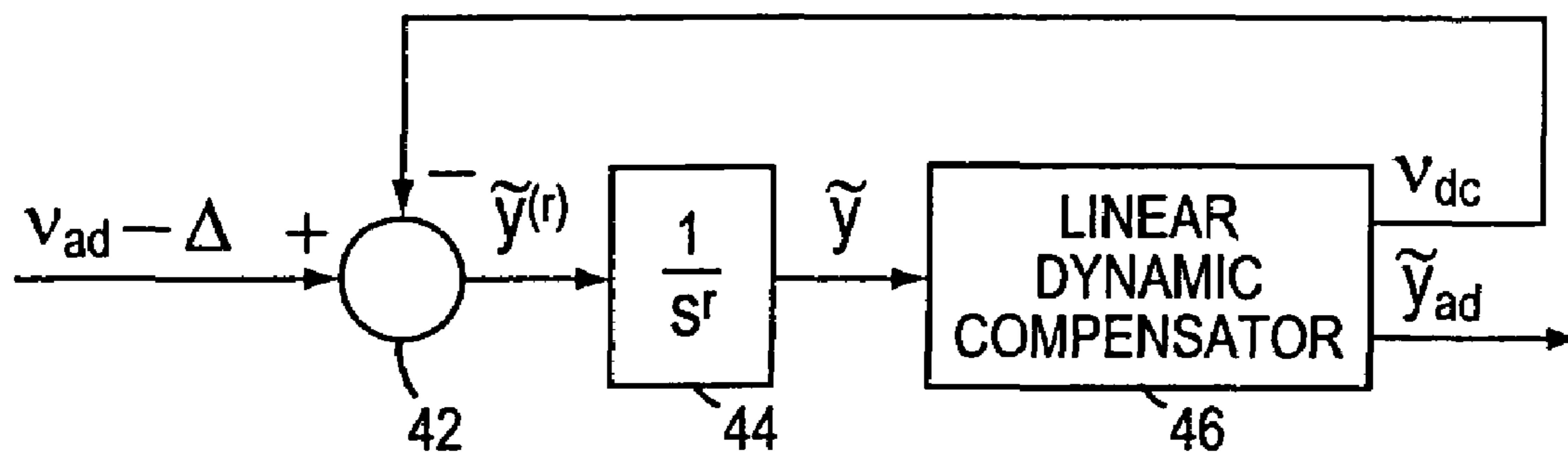

FIG. 2

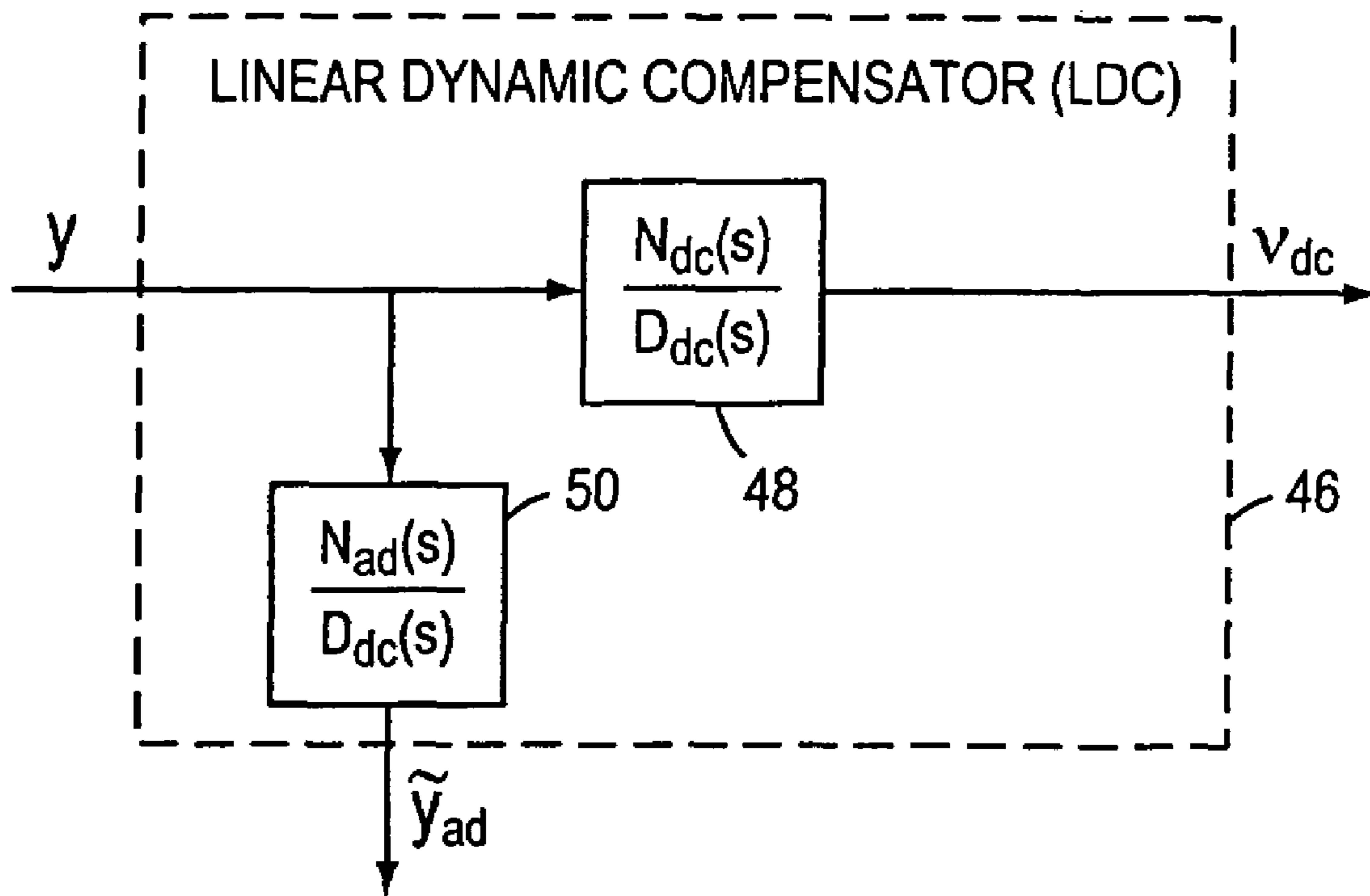

FIG. 3

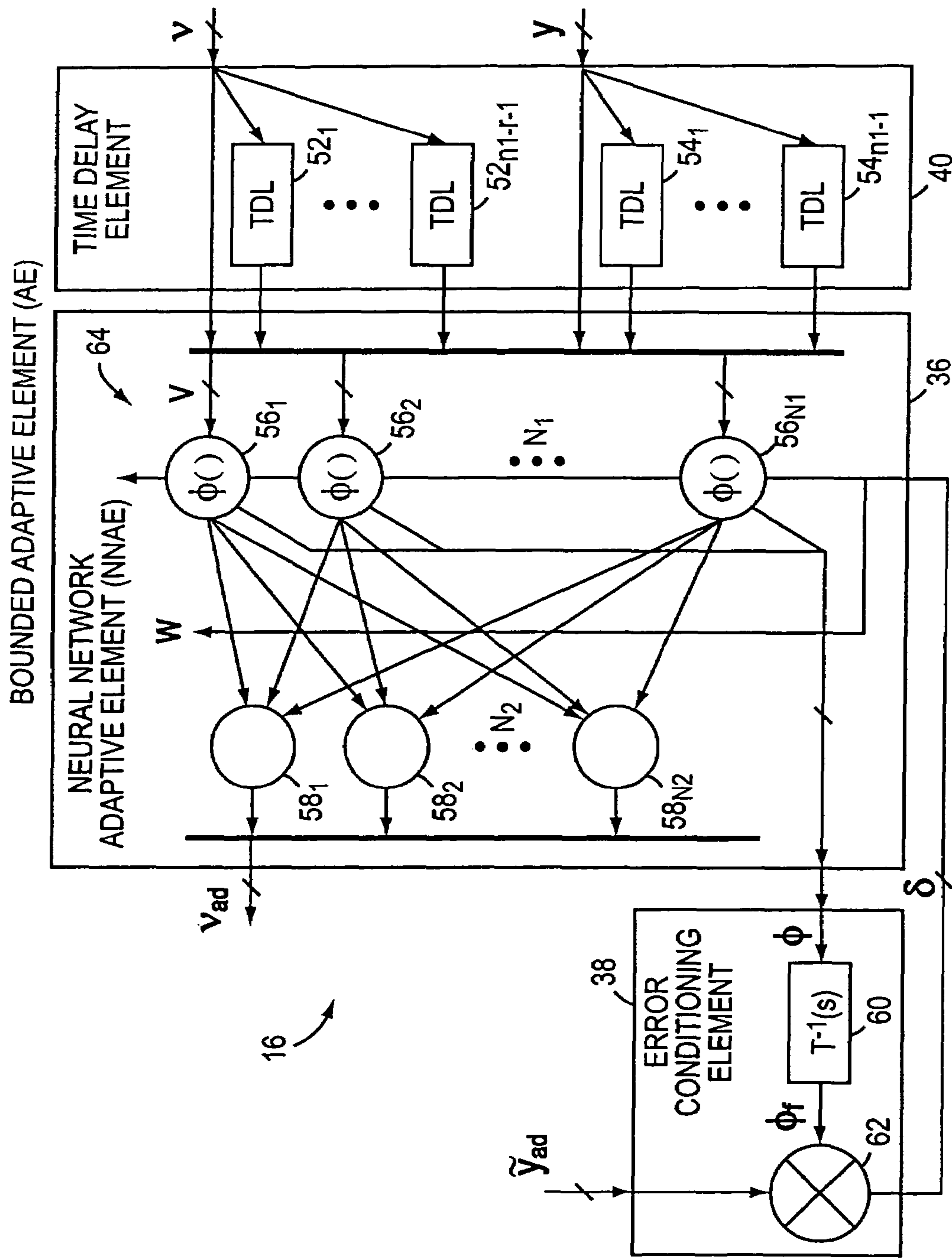

FIG. 4

PROCESSOR-BASED ADAPTIVE CONTROL SYSTEM
USING DIRECT OUTPUT FEEDBACK

10

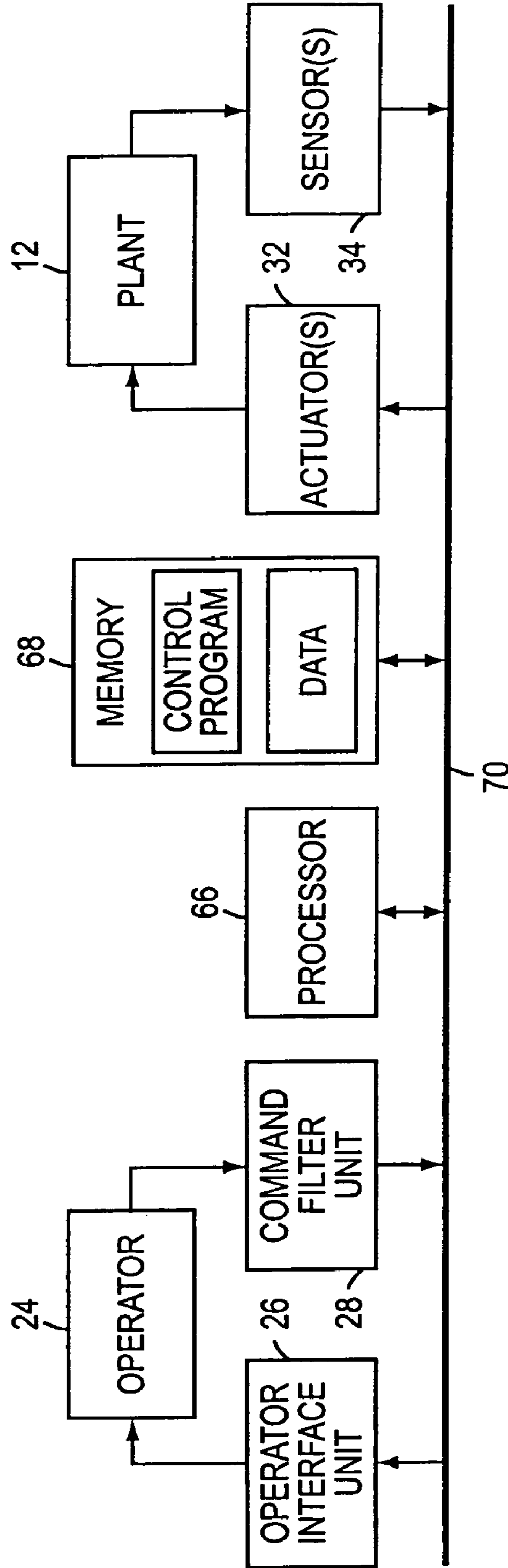

FIG. 5

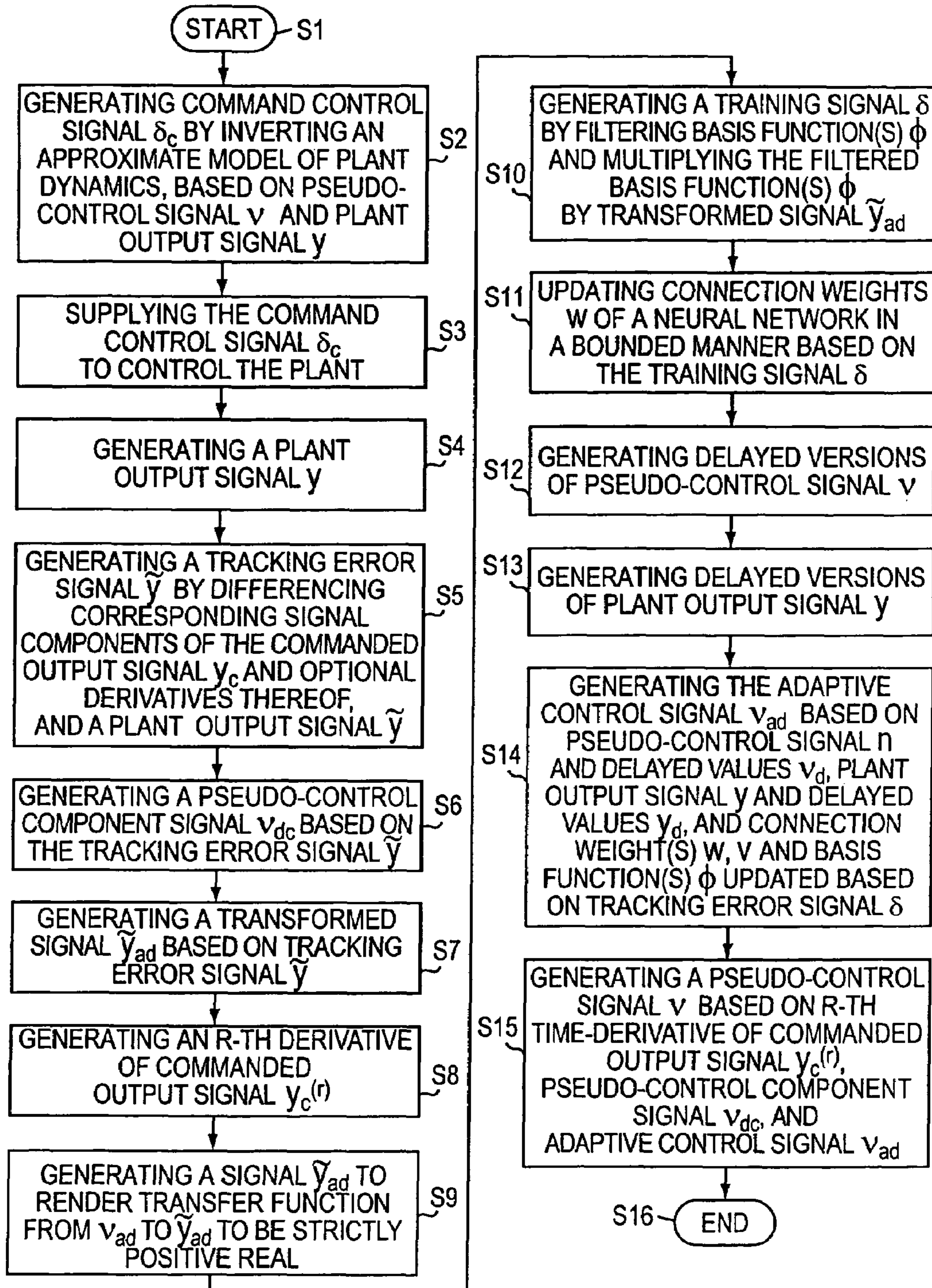
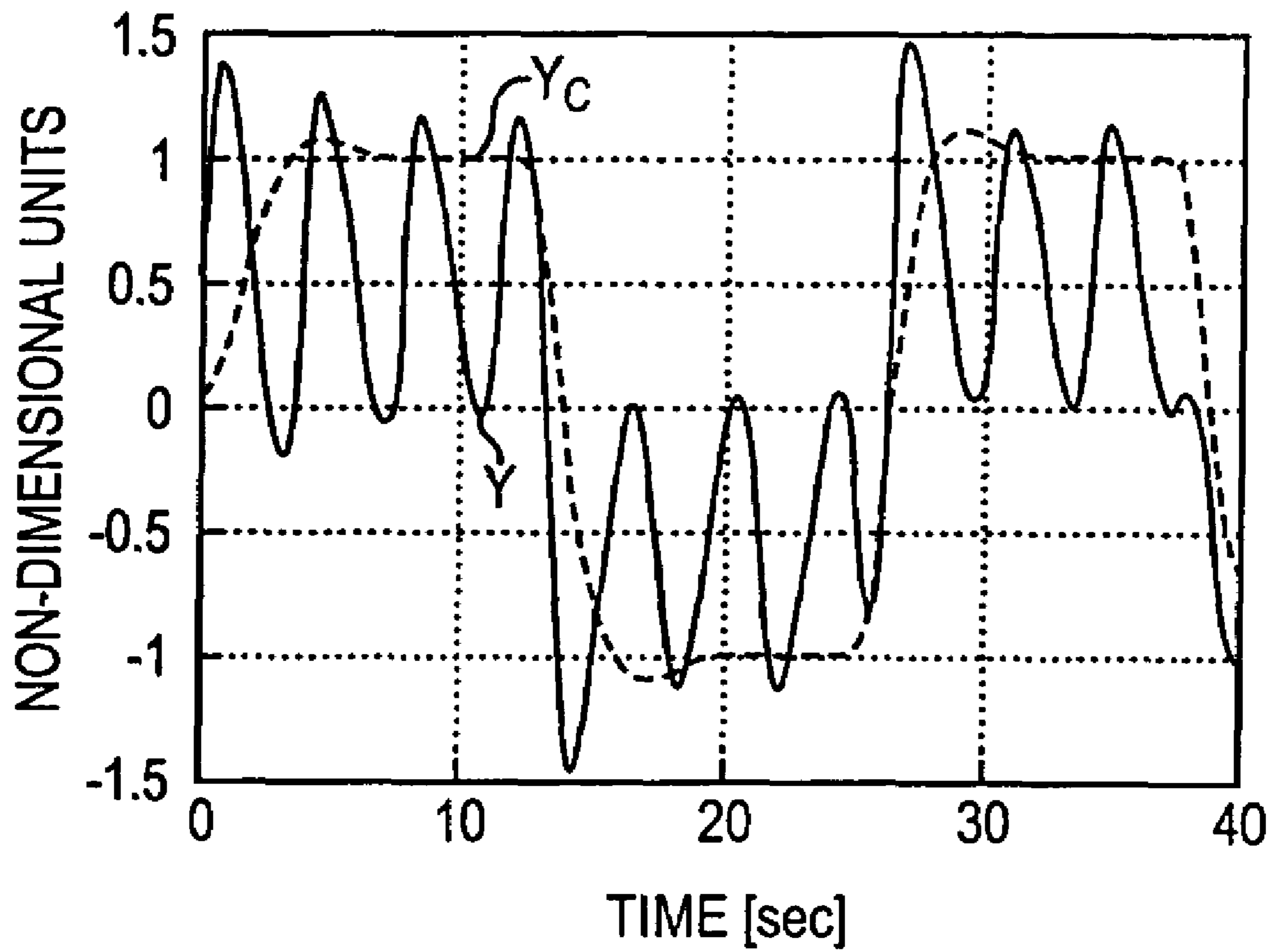

FIG. 6



SYSTEM WITHOUT UNMODELLED DYNAMICS:
RESPONSE WITH LINEAR COMPENSATOR

FIG. 7

SYSTEM WITHOUT UNMODELLED DYNAMICS AND NN CONTROLLER

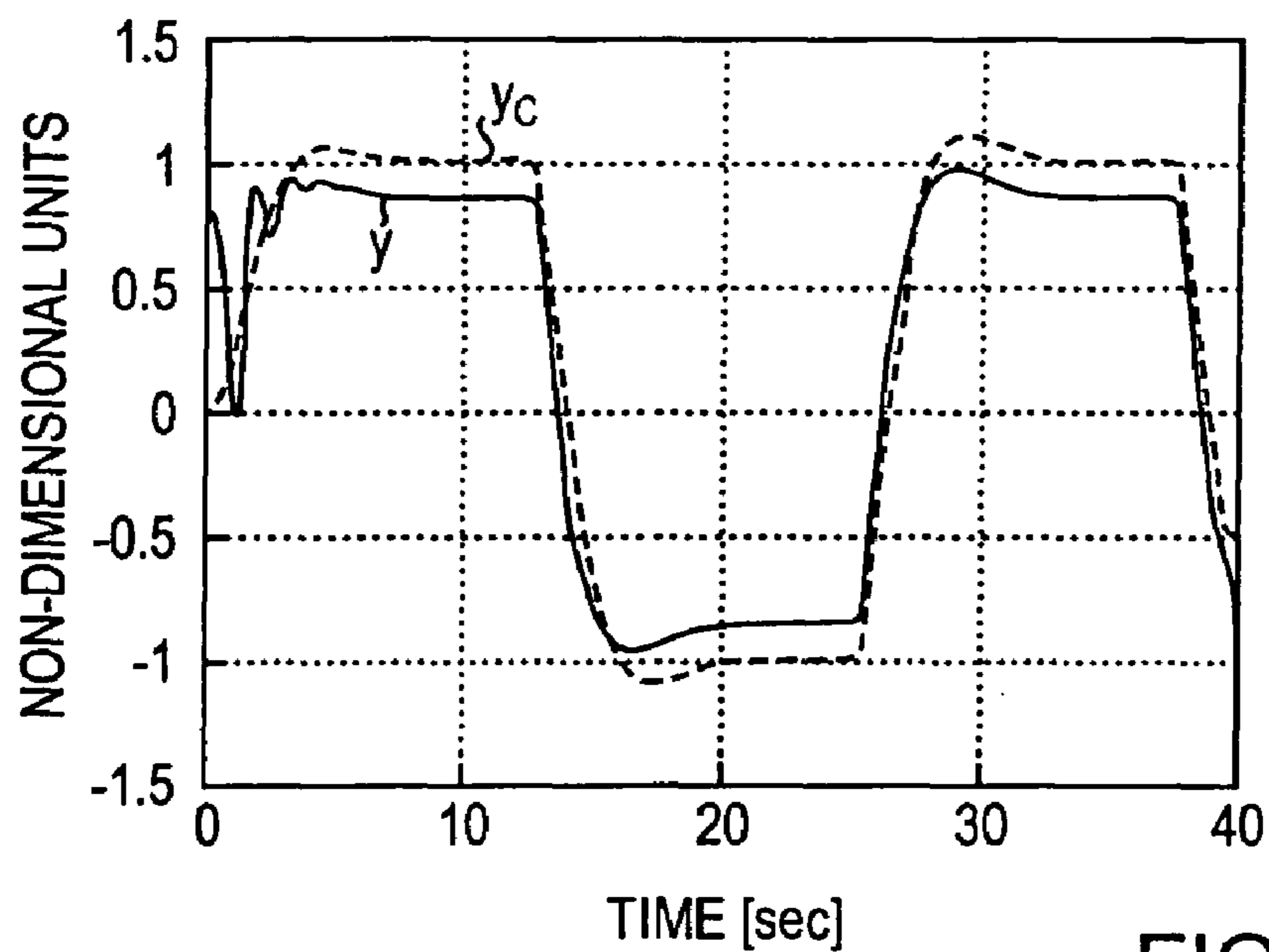

(a) SYSTEM TRACKING

FIG. 8A

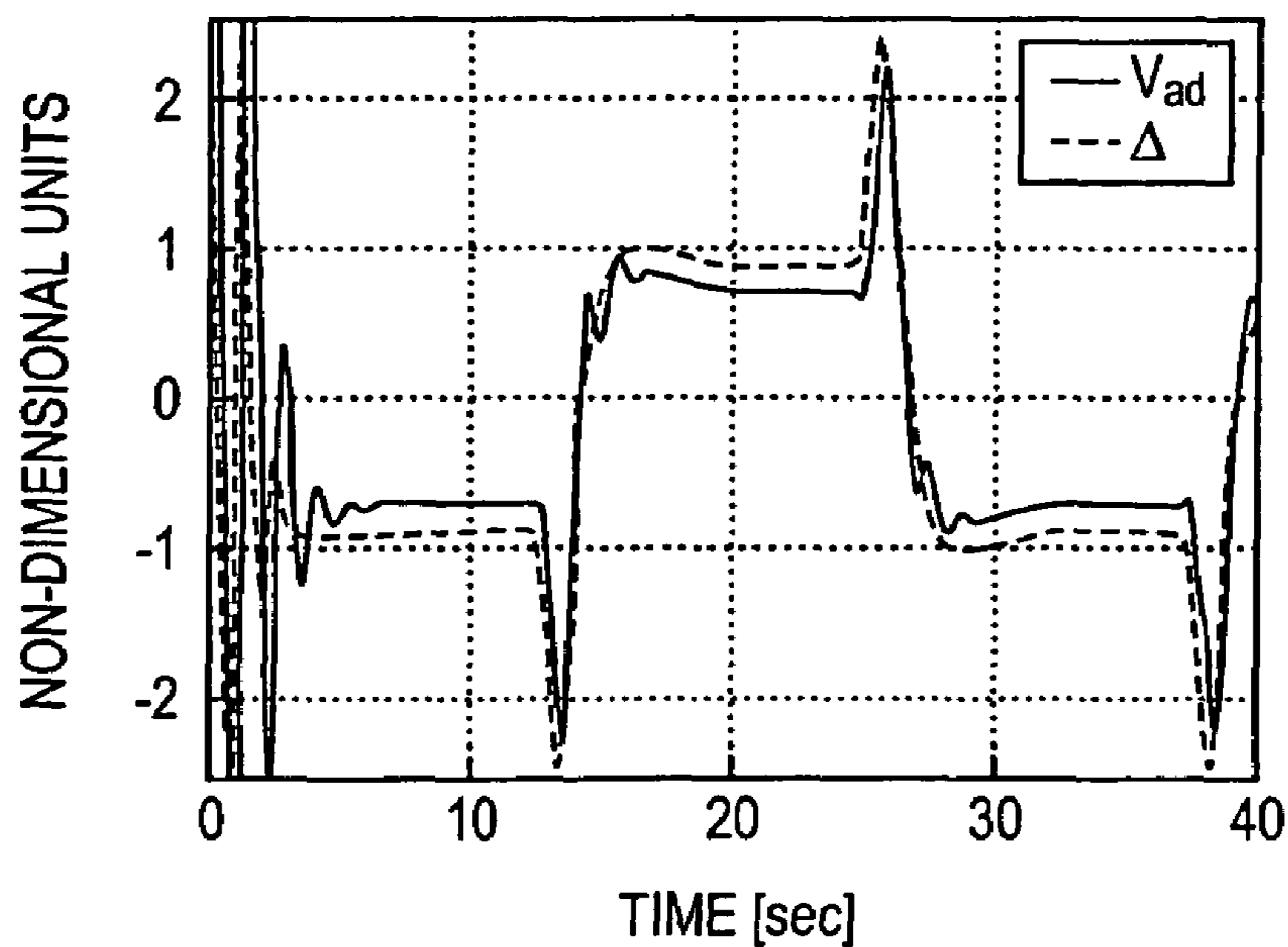

(b) NN OUTPUT V_{ad} AND INVERSION ERROR Δ

FIG. 8B

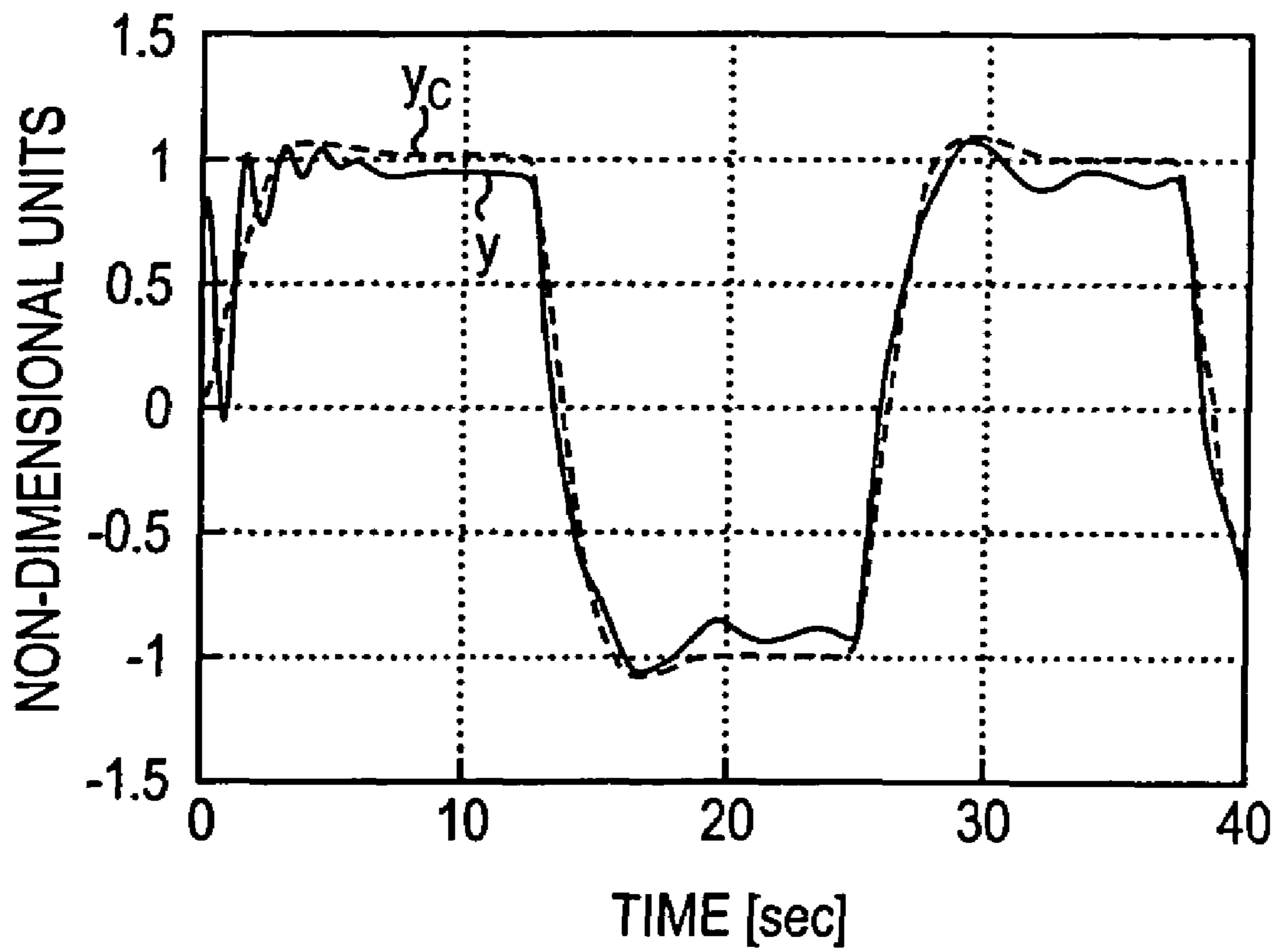

SYSTEM WITH UNMODELLED DYNAMICS:
RESPONSE WITH NN CONTROLLER

FIG. 9

SYSTEM WITH UNMODELLED DYNAMICS:
RESPONSE WITH NN CONTROLLER AND LINEAR COMPENSATOR

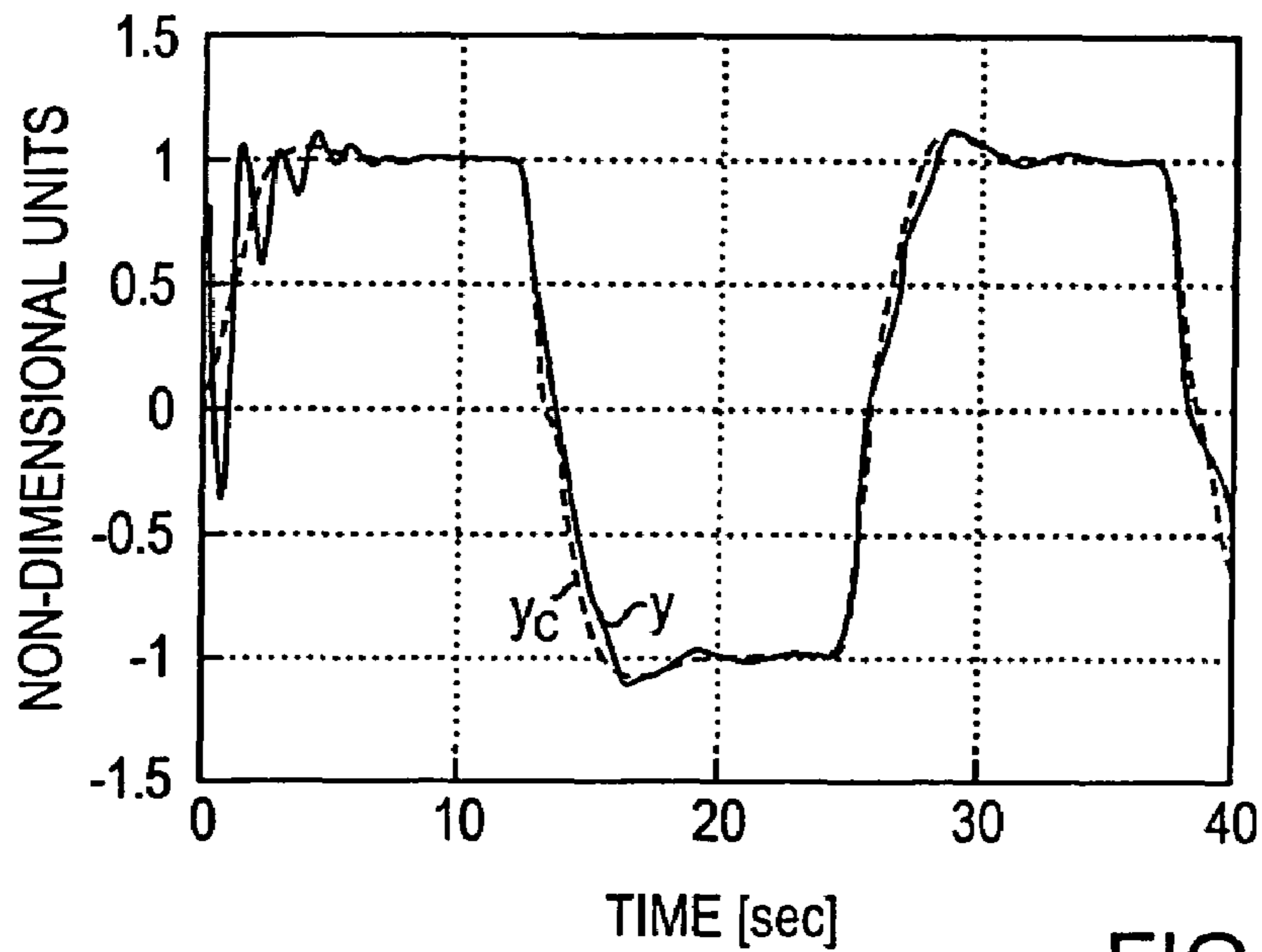

(a) SYSTEM TRACKING

FIG. 10A

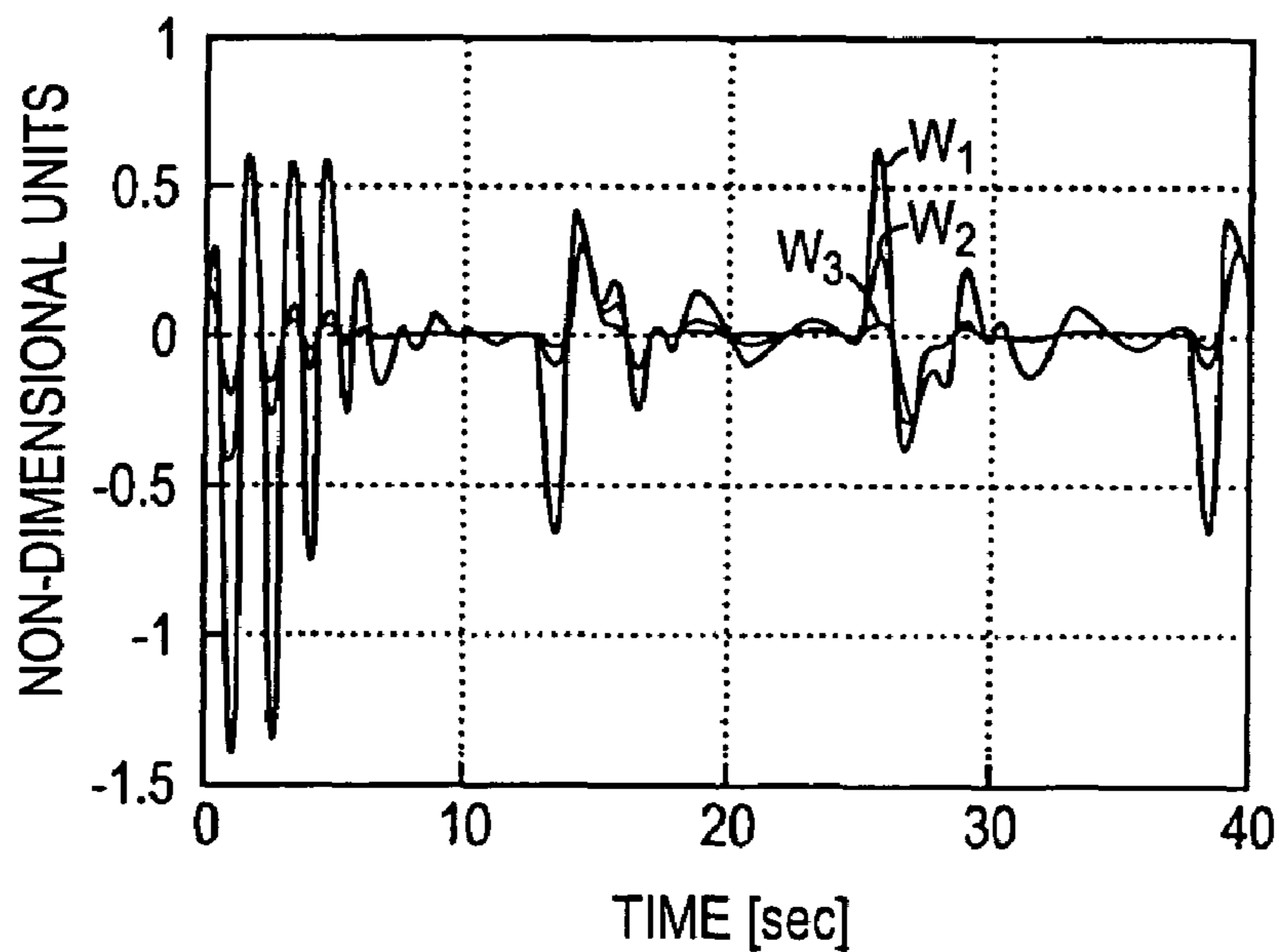

(b) NN WEIGHT HISTORY

FIG. 10B

**ADAPTIVE CONTROL SYSTEM HAVING
DIRECT OUTPUT FEEDBACK AND
RELATED APPARATUSES AND METHODS**

CROSS-REFERENCE TO RELATED
APPLICATIONS

This continuation application claims priority benefits of U.S. provisional application No. 60/208,101 filed May 27, 2000 and nonprovisional application Ser. No. 09/865,659 filed May 25, 2001 now U.S. Pat. No. 6,904,422 naming Anthony J. Calise, Naira Hovakimyan, and Moshe Idan as inventors.

FEDERALLY SPONSORED RESEARCH OR
DEVELOPMENT

This invention was funded in part by the Air Force Office of Scientific Research (AFOSR) under Grant No. F4960-01-1-0024. The United States Government therefore has certain rights in the invention.

FIELD OF INVENTION

The invention is directed to a system, apparatuses and methods for adaptively controlling a plant such an aircraft, automobile, robot, or other controlled system.

BACKGROUND OF THE INVENTION

Research in adaptive output feedback control of uncertain nonlinear dynamic systems is motivated by the many emerging applications that employ novel actuation devices for active control of flexible structures, fluid flows and combustion processes. These include such devices as piezoelectric films, and synthetic jets, which are typically nonlinearly coupled to the dynamics of the processes they are intended to control. Modeling for these applications vary from having accurate low frequency models in the case of structural control problems, to having no reasonable set of model equations in the case of active control of flows and combustion processes. Regardless of the extent of the model accuracy that may be present, an important aspect in any control design is the effect of parametric uncertainty and unmodeled dynamics. While it can be said the issue of parametric uncertainty is addressed within the context of adaptive control, very little can be said regarding robustness of the adaptive process to unmodeled internal process dynamics.

Synthesis approaches to adaptive output feedback control typically make use of state estimation, and therefore require that the dimension of the plant is known. Some approaches further restrict the output to have full relative degree, or restrict the uncertainties in the plant to be an unknown function of the output variables. It would be desirable to remove all these restrictions by adopting a direct output feedback approach that does not rely on state estimation. One of the immediate consequences of such an approach would be that the dimension of the controlled plant need not be known. Consequently, the resulting system would be applicable to plants having both parametric uncertainty and unmodeled dynamics. Furthermore, it would be desirable to produce a control system that is not only robust to unmodeled dynamics, but also learns to interact with and control these dynamics.

Output feedback control of full relative degree systems was introduced by Esfandiari and Khalil, 1992, "Output feedback stabilization of fully linearizable systems," *International Journal of Control*, 56(5):1007-1037. In their publication the

authors formulated a control methodology that involves a high gain observer for the reconstruction of the unavailable states. A solution to the output feedback stabilization problem for systems in which nonlinearities depend only upon the available measurement, was given by Praly, L. and Jiang, Z. (1993), "Stabilization by output feedback for systems with inverse dynamics," *System & Control Letters*, 21:19-33. Krstic, M., Kanellakopoulos, I., and Kokotovic, P. (1995), *Nonlinear and Adaptive Control Design*, John Wiley & Sons, Inc. New York and Marino, R. and Tomei, P. (1995). *Nonlinear Control Design: Geometric, Adaptive, & Robust*. Prentice Hall, Inc., presented backstepping-based approaches to adaptive output feedback control of uncertain systems, linear with respect to unknown parameters. An extension of these methods due to Jiang can be found in Jiang, Z. (1999), A combined backstepping and small-gain approach to adaptive output feedback control. *Automatica*, 35:1131-1139.

For adaptive observer design, the condition of linear dependence upon unknown parameters has been relaxed by introducing a neural network (NN) in the observer structure of Kim, Y. and Lewis, F. (1998), *High Level Feedback Control with Neural Networks*, World Scientific, N.J. Adaptive output feedback control using a high gain observer and radial basis function neural networks (NNs) has also been proposed by Seshagiri, S. and Khalil, H. (2000), "Output feedback control of nonlinear systems using {RBF} neural networks," *IEEE Transactions on Neural Networks*, 11(1):69-79 for nonlinear systems, represented by input-output models. Another method that involves design of an adaptive observer using function approximators and backstepping control can be found in Choi, J. and Farrell, J. (2000), "Observer-based backstepping control using on-line approximation," *Proceedings of the American Control Conference*, pages 3646-3650. However, this result is limited to systems that can be transformed to output feedback form, i.e., in which nonlinearities depend upon measurement only.

The state estimation based adaptive output feedback control design procedure in the Kim and Lewis 1998 publication is developed for systems of the form:

$$\dot{x} = f(x) + g(x)\delta_c \quad (1)$$

$$y = x \quad \dim x = \dim y = \dim u, \quad (2)$$

which implies that the relative degree of y is 2. In Hovakimyan, N., Nardi, F., Calise, A., and Lee, H. (1999), "Adaptive output feedback control of a class of nonlinear systems using neural networks," *International Journal of Control* that methodology is extended to full vector relative degree MIMO systems, non-affine in control, assuming each of the outputs has relative degree less or equal to 2:

$$\dot{x} = f(x, \delta_c) \quad (3)$$

$$y = h(x) \quad \dim y = \dim u \leq \dim x. \quad (4)$$

These restrictions are related to the form of the observer used in the design procedure. Constructing a suitable observer for a highly nonlinear and uncertain plant is not an obvious task in general. Therefore, a solution to adaptive output feedback control problem that avoids state estimation is highly desirable.

BRIEF SUMMARY OF THE INVENTION

The adaptive control system (ACS) and method of this invention uses direct adaptive output feedback to control a plant. The system can comprise a linear controller (LC) and an adaptive element (AE). The linear controller can be used as

a dynamic compensator to stabilize a model of the plant, and provide output regulation. The adaptive element can compensate for disturbances, and modeling error resulting from approximation in modeling of the plant. The adaptive element can comprise a neural network (NN). The adaptive element can receive a signal from the linear controller used to adapt its NN's weights. The input vector to the NN can comprise current and/or past plant output signals together with other available signals. The past plant output signal(s) can be used as inputs to the NN to ensure boundedness of the adaptive element in controlling the plant. The adaptive control system can comprise an error conditioning element having a low-pass filter designed to satisfy a strictly positive real (SPR) condition of a transfer function associated with Lyapunov stability analysis of the control system. The stability analysis can be used to construct the NN adaptation law using only the plant output signal(s) and other available signals as inputs to the NN, and to ensure boundedness of error signal(s) of the closed-loop adaptive control system. Apparatuses forming components of the ACS are also disclosed.

A method of the invention comprises generating at least one control signal δ_c to regulate a plant output signal y by feedback of the plant output signal y , and optionally other sensed variables related to the state of the plant, in which y is a function of the plant state having known but unrestricted relative degree r . The control signal δ_c can be generated so as to control the plant based on an approximate dynamic model, and so as to control the plant in the presence of unmodeled dynamics in the plant based on an adaptive control technique. The adaptive control technique can be implemented with a neural network. Related methods are also disclosed.

These together with other objects and advantages, which will become subsequently apparent, reside in the details of construction and operation of the invented system, methods, and apparatuses as more fully hereinafter described and claimed, reference being made to the accompanying drawings, forming a part hereof, wherein like numerals refer to like parts throughout the several views.

BRIEF DESCRIPTION OF THE DRAWINGS

FIG. 1 is a general block diagram of an adaptive control system for controlling a plant based on a plant output signal y in accordance with the invention;

FIG. 2 is a schematic diagram of the adaptive control system reduced to elements relevant to tracking error signal analysis;

FIG. 3 is a relatively detailed view of a linear dynamic compensator of the adaptive control system;

FIG. 4 is a relatively detailed view of an adaptive element;

FIG. 5 is a block diagram of a processor-based adaptive control system using direct output feedback;

FIG. 6 is a flowchart of a general method of the invention;

FIG. 7 is a graph of commanded output signal y_c (broken line) and plant output signal y (solid line) versus time for a control system without unmodelled dynamics using only a linear compensator to control a plant;

FIG. 8A is a graph of commanded output signal y_c (broken line) and plant output signal y (solid line) versus time for a control system without unmodelled dynamics and with the adaptive element;

FIG. 8B is a graph of adaptive control signal v_{ad} and inversion error signal A for a control system without unmodelled dynamics and with the adaptive element;

FIG. 9 is a graph of commanded output signal y_c (broken line) and plant output signal y (solid line) versus time for a control system with unmodelled dynamics and with the adaptive element;

FIG. 10A is a graph of commanded output signal y_c (broken line) and plant output signal y (solid line) versus time for a control system with unmodelled dynamics, and with the adaptive element; and with the linear controller.

FIG. 10B is a graph of commanded output signal y_c (heavy line), plant output signal y (line with relatively moderate oscillations), and connection weights W (line with relatively heavy oscillations) versus time for a control system with unmodelled dynamics and with an adaptive neural network element and linear controller.

DETAILED DESCRIPTION OF THE INVENTION

As used herein, the following terms have the following definitions:

“Actuator” can be virtually any device capable of affecting the state of a plant to control one or more degrees of freedom thereof. Such actuator can be a motor, motor-driven screw, a hydraulic cylinder, a pump or valve controlling a stream of air, a thermal heater, a compressor or suction generator, or other device.

“Adaptive control system” means a control system having the capability to adapt to changes in a controlled plant or its environment over time.

“And/or” means either one or both of the elements before and after this term. Hence, “A and/or B” means “A” or “B” or “A and B”.

“Direct output feedback” refers to a control system, apparatus or method that employs feedback of an “output” that is a function of the full state(s) existing in a plant. “Direct” refers to the fact that no state estimation is used to estimate plant states not present in or not derivable from the “output”.

“Operator” can be a human or computer, that receives and input and generates and output based on the current and past history of the input, for example, senses a plant output using a plant output signal, and generates a commanded state signal to control the plant.

“Memory” can be a random-access memory (RAM), read-only memory (ROM), erasable read-only programmable memory (EPROM), or other memory device capable of storing a control program and data executable by a processor.

“Plant” refers to a system controlled by a control system. For example, the plant can be an aircraft, spacecraft, space-launch vehicle, satellite, missile, guided munition, automobile, or other vehicle. The plant can also be a robot, or a pointing or orientation system such as a satellite orientation system to orient power-generation panels, a transceiver, or a docking mechanism. Such plant can also be a braking system, an engine, a transmission, or an active suspension, or other vehicle subsystem. The plant can be a manufacturing facility or a power generation facility. In general, the plant could be virtually any controllable system.

“Processor” can be a microprocessor such as a Xeon® or Pentium® brand microprocessor produced by Intel® Corporation, an Athlon® brand microprocessor commercially available from AMD® Corporation, Sunnyvale, Calif., which can operate at one (1) megahertz or more, a microcontroller, a field programmable gate array (“FPGA”), a programmable logic array (“PLA”), a programmed array logic (“PAL”), or other type of data processing or computing device.

“Relative degree” applies to a regulated variable (such as plant output signal y) and corresponds to the number of times the variable must be differentiated with respect to time before

an explicit dependence on the control variable (such as the command control signal δ_c) is revealed.

“Sensor” can be virtually any device(s) for sensing a degree of freedom of a plant’s state, whether alone or in combination with one or more other sensors. The sensor can be virtually any device suitable for sensing information regarding a plant’s state. For example, the sensor could be a gyroscope for detecting orientation of a vehicle such as an aircraft, i.e., pitch or roll attitudes or side slip. The sensor can also be a temperature or pressure sensor, a position, velocity, or inertial sensor.

“(s)” means one or more of the thing meant by the word preceding “(s)”. Thus, basis function(s) means one or more basis functions.

“State” refers to a property of a plant to be controlled which is sufficient to completely define the condition of the plant at any time instant. For example, elements of the state can be a position, velocity, acceleration, mass, energy, temperature, pressure, volume, etc. of an object associated with a plant that is to be controlled.

“State feedback” pertains to a situation in which the entire state of the plant can be sensed and used to control the plant through feedback.

“Strictly positive real” is a property that pertains to the transfer function of a linear time-invariant system. The transfer function, $G(s)$, is a ratio of polynomials in the variable, ‘s’, which is a complex variable having a real and imaginary part. Let $s=a+jb$, where a is the real part and b is the imaginary part. Then the transfer function is called ‘Strictly Positive Real’ if the following two conditions are satisfied:

- 1) $G(s)$ is asymptotically stable (all the poles of $G(s)$ have real parts <0); and
- 2) $G(jb)>0$ for all values of the real variable ‘b’. This definition can be found in Khalil, H. K., “Nonlinear Systems, Second Edition, Prentice-Hall, 1996, p. 404.

“Variable” refers to any signal that can be changed independently of the plant states, such as the control variable, or that are dependent upon time either directly, or indirectly because it depends upon plant states that are time varying, such as the output variable.

The present inventions now will be described more fully hereinafter with reference to the accompanying drawings, in which some, but not all embodiments of the inventions are shown. Indeed, these inventions may be embodied in many different forms and should not be construed as limited to the embodiments set forth herein; rather, these embodiments are provided so that this disclosure will satisfy applicable legal requirements. Like numbers refer to like elements throughout.

Many modifications and other embodiments of the inventions set forth herein will come to mind to one skilled in the art to which these inventions pertain having the benefit of the teachings presented in the foregoing descriptions and the associated drawings. Therefore, it is to be understood that the inventions are not to be limited to the specific embodiments disclosed and that modifications and other embodiments are intended to be included within the scope of the appended claims. Although specific terms are employed herein, they are used in a generic and descriptive sense only and not for purposes of limitation.

1. General Description of Adaptive Control System and Method

As shown in FIG. 1, an adaptive control system (ACS) **10** can be used to control a plant **12** using ‘direct output feedback’ as opposed to ‘state feedback.’ In contrast, the disclosed

adaptive control system **10** uses ‘direct output feedback’ in which a function of the full plant state, as opposed to all plant states or estimates thereof, is used for feedback control of the plant **12**. The adaptive control system **10** of this invention is therefore highly useful in the control of plants, especially non-linear plants in which the full state of the plant cannot be sensed through practical or economically-feasible devices or techniques, particularly if the plant contains unmodeled or unknown dynamics.

In FIG. 1, the ACS **10** comprises a linear controller (LC) **14**, stable adaptive element (AE) **16**, and model inversion unit (MIU) **18**. The ACS **10** can further comprise error signal generator (ESG) **20** and summing unit **22**. The ACS **10** can further comprise an operator **20**, operator interface unit **22**, and command filter unit **24**. These elements permit the operator **22**, which can be human or machine, to interact with ACS **10** to control the plant **18**. The plant **12** comprises a system **30** to be controlled. In general, the system **30** is a non-linear system, although it can be linear. The linear controller **14** is implemented to affect approximate control of the plant, optionally using linear control. The AE **16** serves to implement adaptive control of nonlinearities of the plant **12** that are not compensated by the linear controller **14**. The combined effect of the LC **14** and AE **16** is used to control the plant **12**.

The ACS **10** is now described in further detail. The operator interface unit **26** is coupled to receive the plant output signal y which, as previously described, is a function of the full state of plant **12** having known but unrestricted relative degree r in which r is the number of times the plant output signal y must be differentiated in order for the corresponding control variable, δ_c , to become explicit. The operator interface unit **26** can be an electronic interface between an ACS bus and the operator **24** if implemented as a processor, for example, or can be a display, gauge, meter, light, or other indicator if the operator **24** is human. The operator **24** generates command signals based on the plant output signal y from the operator interface unit **26**. The operator **24** generates a command action or command signal based on the plant output signal y . The operator **24** supplies the command action or command signal to the command filter unit **28** that generates filtered commanded signals y_c and $y_c^{(r)}$ based thereon. The integer r denotes the relative degree of the regulated variable, and signal $y_c^{(r)}$ denotes the r^{th} derivative with respect to time of the filtered commanded signal y_c . The command filter unit **28** is coupled to supply the filtered commanded signal y_c to the error signal generator **20**. The error signal generator **20** is also coupled to receive the plant output signal y . Based on the filtered commanded signal y_c and the plant output signal y , the error signal generator **20** generates a tracking error signal \tilde{y} . The error signal generator **20** is coupled to supply the tracking error signal \tilde{y} to the linear controller **14**.

The linear controller **14** generates a pseudo-control component signal v_{dc} based on the tracking error signal \tilde{y} by operating on such error signal with a summing node, feedback network, and gain multipliers implementing the transfer function $N_{dc}(s)/D_{dc}(s)$. The linear controller **14** also generates a transformed signal \tilde{y}_{ad} based on the tracking error signal \tilde{y} by operating on such error signal with a summing node, one or more integrators, and a feedback network from output terminal(s) of the integrator(s) that have gain multiplier(s) implementing the transfer function $N_{ad}(s)/D_{dc}(s)$. The linear controller **14** generates the transformed signal \tilde{y}_{ad} so that the transfer function from the transformed signal \tilde{y}_{ad} to the adaptive control signal v_{ad} is strictly positive real (SPR). The linear controller **14** is coupled to supply the transformed signal \tilde{y}_{ad} to the AE **16**.

More specifically, the error conditioning element **38** of the AE **16** is coupled to receive the transformed signal \tilde{y}_{ad} . The error conditioning element **38** is also coupled to receive basis function(s) ϕ and generates the training signal δ based on the signal \tilde{y}_{ad} and the basis function(s). The error conditioning element **38** can generate the training signal δ by filtering the basis function(s) ϕ and multiplying the resulting signal ϕ_f by the transformed signal \tilde{y}_{ad} . The error conditioning element **38** is coupled to supply the training signal δ to the neural network adaptive element (NNAE) **36**.

The NNAE **36** uses the training signal δ to adjust connection weights W of its neural network to adapt to plant dynamics that are unmodeled and therefore not adapted to by the LC **14**. The delay element **40** of the AE **16** is coupled to receive the pseudo-control signal v and the plant output signal y and is coupled to supply non-delayed signals v , y , and delayed versions v_d , y_d thereof generated by the delay element **40** based on the signals v , y to the NNAE **36**. The delayed signals y_d are delayed relative to the plant output signal y by time delay increments d to $(n-1)d$, n being the number of the full plant states, although in practice fewer or more such delays may be used. The delayed signal(s) v_d are delayed relative to the pseudo-control signal v by time delay increments d to $(n-r-1)d$, r being the relative degree. The use of these delayed signals assures that the weight coefficient(s), W , and error signal(s) \tilde{y} are bounded so that the ACS **10** is stable.

Based on the connection weight(s) W determined by training signal δ , and the pseudo-control signal v and delayed version(s) v_d thereof and/or the plant output signal y and delayed version(s) y_d thereof supplied as inputs to the NNAE **36**, the NNAE generates the adaptive control signal v_{ad} . The NNAE **36** is coupled to supply the adaptive control signal v_{ad} to the summing unit **22**. The summing unit **22** is also coupled to receive the pseudo-control component signal v_{dc} from the linear controller **14** and the r -th time derivative of the commanded state signal $y_c^{(r)}$ from the command filter unit **28**. Based on the signals $y_c^{(r)}$, v_{dc} , v_{ad} , the summing unit **22** generates the pseudo-control signal v . The summing unit **22** is coupled to supply the pseudo-control signal v to the model inversion unit **18**.

The model inversion unit **18** is also coupled to receive the plant output signal y . The model inversion unit **18** generates a command control signal δ_c based on the pseudo-control signal v and the plant output signal y . More specifically, the model inversion unit **18** subjects the signals v , y to a function that inverts the linear control model implemented by the linear controller **14**, to produce the command control signal δ_c . The model inversion unit **18** is coupled to supply the resulting command control signal δ_c to the actuator(s) **32** of the plant **12**. The actuator(s) **32** are coupled to or associated with the controlled nonlinear system **30** so that the control the state(s) of such system, based on the command control signal δ_c . The sensor(s) **34** are coupled or associated with the controlled nonlinear system **30**, and generates the plant output signal y that is a function of the full plant state(s) of the controlled nonlinear system **30**.

Model inversion in the unit **18** can be performed in the following way. For the scalar case ($p=1$) if the regulated output, y , has relative degree r , then the output equation can be differentiated r times with respect to time until the control appears explicitly. In this case, we assume that we have a model of this r^{th} derivative

$$y^{(r)} = \hat{h}_r(y, \delta_c) = v \quad (5)$$

Thus the model inversion of the unit **18** is defined by

$$\delta_c = \hat{h}_r^{-1}(y, v). \quad (6)$$

2. Specific Description of Adaptive Control System and Method

Let the dynamics of an observable nonlinear single-input-single-output (SISO) system be given by the following equations:

$$\dot{x} = f(x, \delta_c), \quad y = h(x) \quad (7)$$

where $x \in \Omega \subset \mathfrak{R}^n$ is the state of the system, δ_c , $y \in \mathfrak{R}$ the system input (control) and output (measurement) signals, respectively, and $f(\cdot, \cdot)$, $h(\cdot) \in C^\infty$ are unknown functions. Moreover, n need not be known.

To ensure proper operation, the following assumption is made in the implementation of the ACS **10**.

Assumption 1. The dynamical system of Eq. (7) satisfies the output feedback linearization conditions Isidori, A. (1995), Nonlinear Control Systems, Springer-Verlag, Inc. with relative degree r , i.e.,

$$y^{(r)} = h_r(x, \delta_c). \quad (8)$$

Here, $h_r \Delta \frac{d^r h}{dt^r}$, such that $\frac{\partial h_i}{\partial u} = 0$ for $0 \leq i < r$ and

$$\frac{\partial h_r}{\partial u} \neq 0.$$

This disclosure addresses the design of an output feedback control law that utilizes the available measurement $y(t)$, to obtain system output tracking of a bounded trajectory $y_c(t)$ that is assumed to be r -times differentiable, i.e., $y_c \in C^r$. The difference between unknown dynamics function h_r and its estimate \hat{h}_r , or the modeling error, is mapped using a NN. This mapping has to be based on measured input and output data only. To this end, the universal approximation property of neural networks and the observability of the system are utilized to construct this mapping on-line using measured input/output time histories. These various features of the proposed control design scheme are presented in the next section.

3. Controller Design

3.1 Feedback Linearization

Feedback linearization is performed by introducing the transformation

$$v = \hat{h}_r(y, \delta_c), \quad (9)$$

where v is commonly referred to as a pseudo control signal, and $\hat{h}_r(y, \delta_c)$ is the best available approximation of $h_r(y, \delta_c)$. Then, the system dynamics can be expressed as

$$y^{(r)} = v + \Delta', \quad (10)$$

where

$$\Delta' = \Delta'(x, \delta_c) = h_r(x, \delta_c) - \hat{h}_r(y, \delta_c). \quad (11)$$

Using this transformation, Eq. (10) represents the dynamic relation of r integrators between the pseudo-control signal v and the plant output signal y , where the error Δ' acts as a disturbance signal. Assuming that the plant output signal y is required to track a known bounded input command signal y_c , the pseudo-control signal v is chosen to have the form

$$v = y_c^{(r)} + v_{dc} - v_{ad}, \quad (12)$$

where v_{dc} is the output of a stabilizing linear dynamic compensator for the linearized dynamics in Eq. (10) with $\Delta=0$, and v_{ad} is the adaptive control signal designed to approximately cancel Δ . The r-th derivative of the input signal, $y_c^{(r)}$, is introduced as a feedforward term to condition the error dynamics. This derivative can be easily obtained if the tracking (or command) signal y_c is generated using an r-th (or higher) order reference model forced by an external input. The reference model serves to define the desired response of the closed loop system. The input to the dynamic compensator is the tracking error, which is defined by

$$\tilde{y}=y_c-y. \quad (13)$$

It is important to point out that the model approximation function $\hat{h}_r(\cdot, \cdot)$ should be defined so that it is invertible with respect to u , allowing the actual control input to be computed by

$$\delta_c=\hat{h}_r^{-1}(y,v). \quad (14)$$

Clearly, the accuracy of the approximation $h_r(x, \hat{h}_r^{-1}(y,v)) \approx v$ is governed by

$$\Delta'(x, \delta_c)=\Delta(x, y, v)=h_r(x, \hat{h}_r^{-1}(y, v))-v. \quad (15)$$

From Eq. (11) and Eq. (15), notice that Δ depends on v_{ad} through v , whereas v_{ad} has to be designed to cancel Δ . The following assumption is introduced to guarantee existence and uniqueness of a solution for v_{ad} :

Assumption 2. The map $v_{ad} \rightarrow \Delta$ is a contraction over the entire input domain of interest.

Using Eq. (11), the condition in Assumption 2 implies:

$$\left| \frac{\partial \Delta}{\partial v_{ad}} \right| = \left| \frac{\partial (h_r - \hat{h}_r)}{\partial u} \frac{\partial \delta_c}{\partial v} \frac{\partial v}{\partial v_{ad}} \right| = \left| \frac{\partial (h_r - \hat{h}_r)}{\partial u} \frac{\partial \delta_c}{\partial h_r} \right| < 1 \quad (16)$$

which can be re-written in the following way:

$$\left| \frac{\partial h_r / \partial \delta_c}{\partial \hat{h}_r / \partial \delta_c} \right| < 1 \quad (17)$$

The condition (17) is equivalent to the following two conditions

$$\text{sgn}(\partial h_r / \partial \delta_c) = \text{sgn}(\partial \hat{h}_r / \partial \delta_c) \quad (1)$$

$$|\partial \hat{h}_r / \partial \delta_c| > |\partial h_r / \partial \delta_c| / 2 > 0. \quad (2)$$

The first condition means that control reversal is not permitted, and the second condition places a lower bound on the estimate of the control effectiveness in (14).

3.2 Control System Architecture

Based on the above description, the overall control system architecture is presented in FIG. 1. The central components of the system are: (a) the model inversion/linearization unit **18** implementing block $\hat{h}_r^{-1}(y, \delta_c)$, (b) the adaptive neural network based element **16** is designed to minimize the effect of Δ , and (c) the linear dynamic compensator of the linear controller **14**. The input into the ACS **10** is the reference command tracking signal y_c and its r-th derivative $y_c^{(r)}$, generated by, e.g., a reference model forced by an external input.

It is important to note the two output signals (v_{dc} , \tilde{y}_{ad}) of the linear compensator. The pseudo-control component signal, v_{dc} , is designed to stabilize the linearized system, as

described earlier. The transformed signal, \tilde{y}_{ad} , is a linear combination of the compensator states and its input, i.e., the tracking error signal \tilde{y} . This signal is generated to ensure an implementable error signal δ that is used to adapt the NN weights W of the NNAE **36**.

3.3 Tracking Error Signal Analysis

The analysis presented in this subsection is carried out to facilitate the design of the NNAE **36** and the second output signal \tilde{y}_{ad} of the linear dynamic compensator **14**. To formulate the overall tracking error dynamics of the controlled system, the specific choice of the pseudo-control signal v is given by Eq. (12) is substituted into Eq. (16), leading to

$$y^{(r)}=y_c^{(r)}+v_{dc}-v_{ad}+\Delta, \quad (18)$$

or alternately

$$\tilde{y}^{(r)}=-v_{dc}+v_{ad}-\Delta. \quad (19)$$

These error dynamics are depicted schematically in FIG. 2. More specifically, under tracking error dynamics analysis, the ACS **10** reduces to a summing node **42**, an integrator **44**, and a linear dynamic compensator (LDC) **46**. The summing node **42** is coupled to receive the signal $v_{ad}-\Delta$ and the pseudo-control component signal v_{dc} . The summing node **42** subtracts the signal v_{dc} from the signal $v_{ad}-\Delta$ to generate the signal $\tilde{y}^{(r)}$. The r-th degree integrator **44** integrates the signal $\tilde{y}^{(r)}$ to produce the signal \tilde{y} . The LDC **46** is coupled to receive the signal \tilde{y} from the integrator **44**. Based on the signal \tilde{y} , the LDC **46** generates the signal v_{dc} that is feedback to the summing node **42**. The LDC **46** also generates the signal \tilde{y}_{ad} based on the signal \tilde{y} . The LDC **46** implements a transfer function that is SPR to map the signal \tilde{y} to the signal $v_{ad}-\Delta$ to ensure stability of the ADC **10**.

The single-input two-output transfer matrix of the linear dynamic compensator is denoted by

$$\begin{Bmatrix} v_{dc}(s) \\ \tilde{y}_{ad}(s) \end{Bmatrix} = \frac{1}{D_{dc}(s)} \begin{bmatrix} N_{dc}(s) \\ N_{ad}(s) \end{bmatrix} \tilde{y}(s) \quad (20)$$

where s represents the complex Laplace variable. The LDC **46** can comprise transfer function elements **48**, **50**. The transfer function element **48** can be used to implement the transfer function $N_{dc}(s)/D_{dc}(s)$ mapping the signal y to the signal v_{dc} . The transfer function element **50** can be used to implement the transfer function $N_{ad}(s)/D_{dc}(s)$ to map the signal \tilde{y} to the signal \tilde{y}_{ad} . Further details regarding the LDC **46** are described below.

Assumption 3. The linearized system in FIG. 2 is stabilized using a stable linear dynamic compensator **46**, i.e., the roots of the denominator polynomial $D_{dc}(s)$ are located in the open left halfplane of the complex plane s .

Since the linearized system dynamics, and hence the error dynamics, consist of r pure integrators, this assumption introduces only a very mild restriction on the design. Based on the compensator defined in Eq. (20), the closed loop transfer function of the system depicted in FIG. 2 is given by:

$$\tilde{y}_{ad}(s) = \frac{N_{ad}(s)}{s^r D_{dc}(s) + N_{dc}(s)} (v_{ad} - \Delta)(s) \Delta G(s) (v_{ad} - \Delta)(s). \quad (21)$$

Analyzing the denominator of Eq. (21), the Routh-Hurwitz stability criterion implies that a necessary condition for

11

closed loop system stability is that the degree of the compensator numerator, $N_{dc}(s)$, and hence of its denominator, $D_{dc}(s)$, should be at least $(r-1)$, i.e.,

$$q \Delta \deg(D_{dc}(s)) \geq \deg(N_{dc}(s)) \geq r-1. \quad (22)$$

This dictates the design of the linear dynamic compensator

$$v_{dc}(s) = \frac{N_{dc}(s)}{D_{dc}(s)} \tilde{y}(s), \quad (23)$$

which can be carried out using any linear control design technique (classical, pole placement, optimal LQ, etc.), with the constraint of assumption 3. The numerator $N_{ad}(s)$, associated with the output \tilde{y}_{ad} , does not affect the stability of the error system of FIG. 2.

3.4 Neural Network Based Approximation

The term “artificial neural network” has come to mean any architecture that has massively parallel interconnections of simple “neural” processors. Given $x \in \mathfrak{R}^{N_1}$, a three layer-layer NN has an output given by:

$$y_i = \sum_{j=1}^{N_2} \left[w_{ij} \phi \left(\sum_{k=1}^{N_1} v_{jk} x_k + \theta_{vj} \right) + \theta_{wi} \right], \quad i = 1, \dots, N_3 \quad (24)$$

where $\phi(\cdot)$ is the activation function, v_{jk} are the first-to-second layer interconnection weights, and w_{wi} are the second-to-third layer interconnection weights. θ_{vj} and θ_{wi} are bias terms. Such an architecture is known to be a universal approximator of continuous nonlinearities with squashing activation functions. See Funahashi, K. (1989), On the approximate realization of continuous mappings by neural networks. *Neural Networks*, 2:183-192; Hornik, K., Stinchcombe, M., and White, H. (1989), Multilayer feedforward networks are universal approximators, *Neural Networks*, 2:359-366.

Linearly parameterized neural networks

$$y = W^T \phi(x) \quad (25)$$

are universal approximators as well, if vector function $\phi(\cdot)$ can be selected as a basis over the domain of approximation. Then a general function $f(x) \in C^k$, $x \in D \subset \mathfrak{R}^n$ can be written as

$$f(x) = W^T \phi(x) + \epsilon(x), \quad (26)$$

where $\epsilon(x)$ is the functional reconstruction error. In general, given a constant real number $\epsilon^* > 0$, $f(x)$ is within ϵ^* range of the NN, if there exist constant weights W , such that for all $x \in \mathfrak{R}^n$. Eq. (20) holds with $\|\epsilon\| < \epsilon^*$.

Definition 1. The functional range of NNAE 36 is dense over a compact domain $x \in D$, if for any $f(\cdot) \in C^k$ and ϵ^* there exists a finite set of bounded weights W , such that Eq. (26) holds with $\|\epsilon\| < \epsilon^*$.

Various publications show that the functional range of NN in Eq. (25) is dense for different activation functions $\phi(\cdot)$. See Cybenko, G. (1989) publication. Approximation by superpositions of sigmoidal function, *Mathematics of Control, Signals, Systems*, 2(4):303-314; Park, J. and Sandberg, I. (1991), Universal approximation using radial basis function networks, *Neural Computation*, 3:246-257; Sanner, R. and Slo-

12

time, J. (1992), Gaussian networks for direct adaptive control, *IEEE Transactions on Neural Networks*, 3(6):837-864.

The following theorem extends these results to map the unknown dynamics of an observable plant from available input/output history.

Theorem 1. Given $\epsilon^* > 0$, there exists a set of bounded weights W , such that $\Delta(x, y, v)$, associated with the system (1)-(5), can be approximated over a compact domain $D \subset \Omega \times \mathfrak{R}$ by a linearly parameterized neural network

$$\Delta = W^T \phi(\eta) + \epsilon(\eta), \quad \|\epsilon\| < \epsilon^*(\eta), \quad (27)$$

using the input vector

$$\eta(t) = [1 \bar{v}_d^T(t) \bar{y}_d^T(t)]^T, \quad (28)$$

where

$$\bar{v}_d^T(t) = [v(t)v(t-d) \dots v(t-(n_1-r-1)d)]^T$$

$$\bar{y}_d^T(t) = [y(t)y(t-d) \dots y(t-(n_1-1)d)]^T$$

with $n_1 \geq n$ and $d > 0$, provided there exists a suitable basis of activation functions $\phi(\cdot)$ on the compact domain D .

The output of the adaptive element 16 in FIG. 1 is designed as

$$v_{ad} = \hat{W}^T \phi(\eta), \quad (29)$$

where \hat{W} are the estimates of the weights. Eq. (29) will always have at least one fixed-point solution, so long as $\phi(\cdot)$ is made up of bounded basis functions.

3.5 Construction of SPR Transfer Function

As discussed earlier, the second output of the linear dynamic compensator 46, \tilde{y}_{ad} , will be used to construct the rule for adapting \hat{W} in Eq. (29). Using Eqs. (27) and (29) in Eq. (21) implies:

$$\tilde{y}_{ad}(s) = G(s)(\hat{W}^T \phi(\eta) - \epsilon) \quad (30)$$

where $W = \hat{W} - W$ is the weight error. As will be seen in the next section, for the NN adaptation rule to be realizable, i.e. dependent on available data only, the transfer function $G(s)$ must be strictly positive real (SPR). However, the relative degree of $G(s)$ is at least r . When the relative degree of $G(s)$ is one, it can be made SPR by a proper construction of $N_{ad}(s)$. If $r > 1$, $G(s)$ cannot be SPR through this technique alone.

To achieve SPR in the $r > 1$ case, following the Kim and Lewis, 1998 publication, a stable low pass filter $T^{-1}(s)$ is introduced in Eq. (30) as:

$$\tilde{y}_{ad}(s) = G(s)T(s)(\hat{W}^T \phi_f + \delta - \epsilon_f)(s) \quad (31)$$

where ϕ_f and ϵ_f are the signals ϕ and ϵ , respectively, after being filtered through $T^{-1}(s)$, and $\delta_m(s)$ is the “so-called” mismatch term given by

$$\delta_m(s) = T^{-1}(s)(\hat{W}^T \phi) - W^T \phi_f \quad (32)$$

that can be bounded as

$$\|\delta_m(t)\| \leq c \|\hat{W}\|_F, \quad c > 0. \quad (33)$$

The numerator of the transfer function $G(s)T(s) = \bar{G}(s)$ in Eq. (31) is $T(s)N_{ad}(s)$. The polynomial $T(s)$ is Hurwitz, but otherwise can be freely chosen, along with the numerator polynomial $N_{ad}(s)$ of Eq. (21) that defines the output \tilde{y}_{ad} . Hence, the numerator polynomial (or the zeros) of $\bar{G}(s)$ can be freely chosen to make it SPR. Two approaches can be utilized in constructing $T(s)$ and $N_{ad}(s)$ to make $\bar{G}(s)$ SPR. To avoid an

troller in Eq. (14) and the NN adaptation rule in Eq. (40), are uniformly ultimately bounded, provided the following conditions hold

$$Q_m > 2\|C_{c1}\|, \lambda_W > c^2/4, \quad (41)$$

where Q_m is the minimum eigenvalue of Q .

5. Processor-based Embodiment of Adaptive Control System Using Direct Output Feedback

Although it is possible to implement the elements 14, 16, 18, 20, and 22 of the ACS 10 of FIG. 1 as discrete or grouped analog or digital devices, these elements can alternatively be implemented in a processor-based ACS system 10. The processor-based system 10 includes a processor 66 and memory 69 storing data and a control program, to implement the elements 14, 16, 18, 20, and 22. More specifically, the control program can be implemented as software objects or modules that perform the functions of the elements 14, 16, 18, 20, 22 as previously described. The data can be parameters such as the NN connection weights W , V and/or basis function(s) ϕ that are updated by the processor 66, as well as temporary data and intermediate calculations, commanded state signal levels, plant output signal levels, etc. The ACS 10 of FIG. 5 can further comprise bus 70 to which the operator interface unit 26, the command filter unit 28, the actuator 32, the sensor(s) 34, the processor 66, and the memory 68, are coupled.

In operation, the sensor(s) 34 generate plant output signal y and supply this signal to the operator interface unit 26 via the bus 70. The operation interface unit 26 generates a signal readable or discernible by the operator. If the operator 24 is human, the operator interface unit 26 can generate a display or the like based on the plant output state signal y . If the operator 24 is a processor or machine, the operator interface unit 26 can convert the plant output state signal y into a format usable by the operator. The operator 24 if human produces one or more signals through control actions applied to a command filter unit 28. For example, in the case of an aircraft, the control actions may be applied to control instruments of the aircraft. Alternatively, if the operator 24 is a machine, the command signal produced by the operator can be applied to the command filter unit 28. The command filter unit 28 generates the commanded output signal y_c and the r th derivative of the commanded output signal $y_c^{(r)}$. The command filter unit 28 supplies the signals y_c , $y_c^{(r)}$ to the processor 66 or to the memory 68 at a location accessible to the processor 66. The sensor(s) 34 can supply the plant output signal y directly to the processor 66, or to the memory 68 at a location accessible to the processor 66 via the bus 70. The processor 66 performs the functions of the elements 14, 16, 18, 20, 22 to generate a command control signal δ_c . The processor 66 is coupled to supply the command control signal δ_c to the actuator(s) 32 via the bus 70. The actuator(s) 32 perform control of the plant 12 in a manner that can affect the plant state(s). The sensor(s) 34 sense and generate the plant output signal y for the next control cycle. Processing performed by the processor 66 in executing its control program can be repeated over successive control cycles as long as required to control the plant 12.

6. General Method of the Invention

FIG. 6 is a flowchart of processing performed by the ACS 10 of FIGS. 1-5. In step S1 of FIG. 6 the method begins. In step S2 a command control signal δ_c is generated by inverting an approximate model of the plant dynamics, based on a

pseudo-control signal v and the plant output signal y . In step S3 the command control signal δ_c is supplied to control the plant. In step S4 the plant output signal y is generated by the sensors. In step S5 a tracking error signal \tilde{y} is generated by differencing corresponding signal components of the commanded output signal y_c and optional derivative(s) thereof, and the plant output signal y . In step S6 a pseudo-control component signal v_{dc} is generated based on the tracking error signal \tilde{y} using the transfer function $N_{dc}(s)/D_{dc}(s)$. In step S7 a transformed signal \tilde{y}_{ad} is generated based on the tracking error signal \tilde{y} using transfer function $N_{ad}(s)/D_{dc}(s)$. In step S8 the r th derivative of the commanded output signal $y_c^{(r)}$ is generated. In step S9 the signal \tilde{y}_{ad} is generated to render the transfer function from the signal v_{ad} to the signal \tilde{y}_{ad} strictly positive real by appropriate choice of $N_{ad}(s)$. In step S10 a training signal δ is generated by filtering basis function(s) ϕ and multiplying the filtered basis function(s) ϕ by the transformed signal y_{ad} . In step S11 connection weights W of a neural network are updated in a bounded manner using the training signal δ . In step S12 delayed versions of the pseudo-control signal v are generated. In step S13 delayed versions of the plant output signal y are generated. In step S14 the adaptive control signal v_{ad} is generated based on the pseudo-control signal v , delayed versions v_d of the signal v , plant output signal y , plant output signal y_d , connection weights W , V , and basis function(s) ϕ updated based on the training error signal δ . In step S15 a pseudo-control signal v is generated based on the r th time-derivative of the commanded output signal $y_c^{(r)}$ pseudo-control component signal v_{dc} , and adaptive control signal v_{ad} . In step S16 the method of FIG. 6 ends.

7. Example of Implementation of the Adaptive Control System Having Direct Output Feedback Control

The performance of the ACS 10 using output feedback is demonstrated by considering the following nonlinear system, consisting of a modified Van der Pol oscillator coupled to a lightly damped mode

$$\dot{x}_1 = x_2 \quad (42)$$

$$\dot{x}_2 = -2(x_1^2 - 1)x_2 - x_1 + u \quad (43)$$

$$\dot{x}_3 = x_4 \quad (44)$$

$$\dot{x}_4 = -x_3 - 0.2x_4 + x_1 \quad (45)$$

$$y = x_1 + x_3 \quad (46)$$

The output y has a relative degree of $r=2$. From a practical perspective, the system can be thought of as a second order nonlinear plant model, whose realization consists of states x_1 and x_2 , in which the output is modeled as $y=x_1$. However, the system contains also a very lightly damped unmodeled mode, with a natural frequency equal to that of the linearized plant. This mode is excited by the plant displacement state (x_1) and is coupled to the measurement.

The output signal y does not have a full relative degree in the presence of the unmodeled mode. The low natural frequency of this mode is encompassed by the bandwidth of the controlled system. This introduces a challenging control problem, in particular for methods that require the output to have a full relative degree. Moreover, this example is treated as if even the Van der Pol model is unknown, and only the fact that $r=2$ is given. This is not an unreasonable assumption in that in many systems, the number of plant states and hence the value of r can be deduced from knowledge of the behavior of

the plant. Thus, the controller design is performed assuming $\dot{y}=u$, implying that in FIG. 1 the plant transfer function from the pseudo-control signal v to y is $1/s^2$.

A first order lead-lag compensator was selected to stabilize the associated error dynamics. In addition, the first design approach described in Section 3.5 was used to satisfy the SPR condition. The resulting two outputs of the compensator are given by

$$\begin{Bmatrix} v_{dc}(s) \\ \tilde{y}_{ad}(s) \end{Bmatrix} = \frac{1}{s+5} \begin{bmatrix} 8(s+0.75) \\ 20(s+1) \end{bmatrix} \tilde{y}(s) \quad (50)$$

which places the closed loop poles of the error dynamics at $-3, -1 \pm j$. The low pass filter $T^{-1}(s)$ discussed in Eq. (26) was chosen as

$$T^{-1}(s) = \frac{1}{0.5s+1}. \quad (51)$$

It is easy to verify that the transfer function $G(s)T(s)$ of Eq. (31) is SPR.

A Gaussian Radial Basis Function (RBF) NN with only three neurons and a bias term was used in the adaptive element. The functional form for each RBF neuron was defined by

$$\phi_i(\eta) = e^{-(\eta - \eta_{ci})^T (\eta - \eta_{ci}) / \sigma^2}, \quad \sigma = \sqrt{2}, \quad i=1, 2, 3. \quad (52)$$

The centers η_{ci} , $i=1, 2, 3$ were randomly selected over a grid of possible values for the vector η . All of the NN inputs were normalized using an estimate for their maximum values. The current and two delayed values for the plant output signal y and only the current pseudo-control signal v were used in the input vector to the neurons. The complete input vector consisted of these values together with a bias term, as illustrated in FIG. 4. Thus, there are a total of four NN weights in Eq. (29). The network gains were $F=50$ and $\lambda_w=1$.

In the simulation, the initial states of the system were set to $x_1(0)=0.5$, $x_2(0)=2.5$, $x_3(0)=x_4(0)=0$. The system was commanded to follow the output of a second order reference model for the MIU 18, designed with a natural frequency of $\omega_n=1\sqrt{2}$ rad/sec and damping $\zeta=2/\sqrt{2}$, and driven by a square wave input command signal y_c .

First, the controlled system performance is evaluated without the unmodeled mode dynamics, i.e., removing Eqs. (44) and (45) and setting the output $y=x_1$. However, it will be recalled that the controller has been designed given only the fact that $r=2$. FIG. 7 compares the system response without NN augmentation (solid line) with the reference model output (dashed line), clearly demonstrating the almost unstable oscillatory behavior caused by the nonlinear elements in the Van del Pol equation. FIGS. 8A and 8B show that with NN augmentation, these oscillations are eliminated after a period of about three seconds. This is accounted for by the successful identification of the model inversion error by the NN, which is also illustrated in FIG. 8B by comparing the NN output (solid line) with the computed inversion error (dashed line).

Next, the effect of the unmodelled dynamics is examined. In this case, the response without the NN is unstable, and therefore is not shown. The response with NN augmentation is presented in FIG. 9. It shows only minor performance degradation compared to the full relative degree case of FIG. 8A. Since the unmodeled mode is well within the bandwidth

of the control system (when viewed with, $v_{ad}=\Delta$), this demonstrates that the adaptive system learns to interact with the added mode to achieve good tracking performance.

In FIGS. 8A, 8B, 9 the NN based adaptive controller exhibits a steady state tracking error. This error can be removed by introducing an additional integral control action when designing the linear compensator. The performance of the controller with integral action is shown in FIGS. 10A and 10B. The steady state tracking error is zero, while the transient response behavior is only slightly compromised. The bounded NN weight time histories are also depicted in this figure, showing that most of the weight adaptation takes place when the command reverses direction.

8. Additional Considerations

The stability results are semiglobal in the sense that they are local with respect to the domain D . If the NN universally approximates the inversion error over the whole space \mathcal{R}^{n+1} , then these results become global.

The NN update laws consist of a modified gradient algorithm along with the standard σ -modification term as described in the Kim and Lewis 1998 publication. These laws have been proven to be passive in Lewis, F. (1999), Nonlinear network structures for feedback control, *Asian Journal of Control*, 1(4):205-228.

The NN learning takes place on-line, and no off-line training is required. No assumption on persistent excitation is required.

The ultimate bound for the tracking error can be made smaller by increasing the linear design gains. This will result in increased interaction with unknown or unmodeled plant dynamics. However, Theorem 2 remains valid so long as assumptions 2 and 3 hold.

In the case of plants of unknown dimension but with known relative degree, the described methodology applies with a slight modification of the input vector to the network: a large range of input/output data should be used, i.e., $n_1 \gg n$.

9. CONCLUSION

The described ACS 10 presents an adaptive output feedback control design procedure for nonlinear systems, that avoids state estimation. The main advantage is that the stability analysis permits systems of arbitrary but known relative degree. The full dimension of the plant and its internal dynamics may be known or poorly modeled. Only mild restrictions regarding observability and smoothness are imposed. Consequently, the result is applicable to adaptive control of nonlinear systems with parametric uncertainty and unmodeled dynamics.

Any trademarks listed herein are the property of their respective owners, and reference herein to such trademarks is intended only to indicate the source of a particular product or service.

The many features and advantages of the present invention are apparent from the detailed specification and it is intended by the appended claim to cover all such features and advantages of the described methods and apparatus which follow in the true scope of the invention. Further, since numerous modifications and changes will readily occur to those of ordinary skill in the art, it is not desired to limit the invention to the exact implementation and operation illustrated and described. Accordingly, all suitable modifications and equivalents may be resorted to as falling within the scope of the invention.

That which is claimed:

1. An adaptive control system (ACS) for controlling a plant having a number of unknown internal states, said plant comprising at least one sensor and at least one actuator, said ACS comprising an adaptive controller operatively connected to the at least one sensor to receive a plant output signal y and operatively connected to the at least one actuator to generate at least one control signal δ_c to control the plant based on a plant output signal y , the adaptive controller being operatively connected to receive the plant output signal y from at least one sensor without knowledge of the internal states by output feedback from the plant and generating the control signal δ_c to regulate the plant output signal y , the plant output signal y being a function of the full plant state x having known but unrestricted relative degree r .

2. An ACS as claimed in claim 1 wherein the adaptive controller comprises a linear controller contributing to generation of the control signal δ_c to control the plant based on the plant output signal y and an approximate linear dynamic model of the plant, and further comprises an adaptive element contributing to generation of the control signal δ_c based on the plant output signal y to control unmodeled plant dynamics using adaptive control.

3. An ACS as claimed in claim 2 wherein the adaptive element comprises a neural network implementing adaptive control of the plant via the control signal δ_c based on the plant output signal y .

4. An ACS as claimed in claim 3 wherein the adaptive element uses at least one time-delayed version y_d of the plant output signal y , that is supplied together with the plant output signal y as inputs to the neural network, the neural network generating an adaptive control signal v_{ad} contributing to generation of the control signal δ_c to control the plant output y despite unmodeled plant dynamics, based on the time-delayed signal y_d and the plant output signal y , the time-delayed version signal y_d and the plant output signal y , to ensure boundedness of the tracking error signal \tilde{y} , the tracking error signal \tilde{y} being a difference of the plant output signal y and a commanded plant output signal y_c .

5. An ACS as claimed in claim 3 wherein the neural network of the adaptive element comprises at least one basis function ϕ and at least one connection weight W used to generate an adaptive control signal v_{ad} contributing to generation of the command control signal δ_c , the adaptive element further comprising an error conditioning element coupled to receive the basis function ϕ , the error conditioning element filtering the basis function ϕ with a transfer function $T^{-1}(s)$ to produce filtered basis function ϕ_f used to modify the connection weight(s) W of the neural network through feedback to ensure boundedness of the tracking error signal \tilde{y} .

6. An ACS as claimed in claim 1 wherein the adaptive controller comprises a command filter unit generating an r th derivative $y_c^{(r)}$ of the plant output signal y in which r is an integer indicating the number of times the plant output signal y must be differentiated with respect to time before an explicit dependence on the control variable is revealed.

7. An ACS as claimed in claim 1 wherein the adaptive controller comprises:

an error signal generator generating a tracking error signal \tilde{y} indicating the difference between the plant output signal y and a commanded output signal y_c ;

a linear controller coupled to receive the tracking error signal \tilde{y} , the linear controller generating a transformed signal \tilde{y}_{ad} based on the tracking error signal \tilde{y} ; and

an adaptive element coupled to receive the transformed signal \tilde{y}_{ad} and generating an adaptive control signal v_{ad} based thereon, the adaptive element operating on the

transformed signal \tilde{y}_{ad} to generate the adaptive signal v_{ad} such that the transfer function from v_{ad} to \tilde{y}_{ad} is strictly positive real (SPR).

8. An ACS as claimed in claim 1 wherein sensed variables affecting the state of the plant, in addition to the plant output signal y , are fed back to the ACS to control the plant.

9. A linear controller coupled to receive a tracking error signal \tilde{y} that is a vector difference of a plant output signal y that is a function of a full plant state having known but unrestricted relative degree r , and a commanded output signal y_c , the linear controller generating a pseudo-control component signal v_{dc} based on a transfer function $N_{dc}(s)/D_{dc}(s)$ and the tracking error signal \tilde{y} , the pseudo-control component signal v_{dc} used by the linear controller to control the plant based on an approximate linear model of the plant, and the linear controller generating a transformed signal \tilde{y}_{ad} based on a transfer function $N_{ad}(s)/D_{dc}(s)$ and the tracking error signal \tilde{y} , the transformed signal \tilde{y}_{ad} supplied by the linear controller and used for adaptive control of the plant, the transfer functions $N_{dc}(s)/D_{dc}(s)$ and $N_{ad}(s)/D_{dc}(s)$ selected to assure boundedness of the tracking error signal \tilde{y} .

10. A method comprising the step of:

a) generating at least one control signal δ_c to control a plant having a number of unknown internal states based on a plant output signal y using an adaptive control system (ACS), the ACS connected to receive the plant output signal y from at least one sensor without knowledge of the internal states by output feedback from the plant to the ACS, the ACS generating the control signal δ_c to regulate the plant output signal y , the plant output signal y being a function of the full plant state x having known but unrestricted relative degree r ; and

b) supplying the control signal δ_c to at least one actuator used to control the plant.

11. A method as claimed in claim 10 wherein the control signal δ_c is generated in step (a) so as to control the plant output based on an approximate linear dynamic model, and so as to control the plant despite unmodeled plant dynamics based on an adaptive control technique.

12. A method as claimed in claim 10 wherein the adaptive control technique is implemented with a neural network.

13. A method as claimed in claim 10 wherein the command control signal δ_c is generated in step (a) based on sensed variables affecting the state x of the plant in addition to the plant output signal y .

14. A method comprising the steps of:

a) selecting a transfer function $N_{dc}(s)/D_{dc}(s)$ used in control of a plant based on a plant output signal y that is a function of states x existing in the plant, $N_{dc}(s)$ being the numerator and $D_{dc}(s)$ being the denominator of the transfer function $N_{dc}(s)/D_{dc}(s)$ relating the tracking error signal \tilde{y} representing a vector difference between the plant output signal y and a commanded output signal y_c , to a linear portion of a pseudo-control signal v_{dc} used to control the plant;

b) selecting a transfer function $N_{ad}(s)/D_{dc}(s)$ used in adaptive control of the plant based on the plant output signal y , $N_{ad}(s)$ being the numerator and $D_{dc}(s)$ being the denominator of the transfer function $N_{ad}(s)/D_{dc}(s)$ relating the tracking error signal \tilde{y} to an adaptive portion of the tracking error signal \tilde{y}_{ad} used to generate an adaptive portion of the pseudo-control signal v_{ad} ;

said steps (a) and (b) assuring boundedness of the tracking error signal \tilde{y} ; and

c) physically controlling the plant based on the linear portion of the pseudo-control signal v_{dc} and the adaptive portion of the pseudo-control signal v_{ad} based on the

21

selected transfer functions $N_{dc}(s)/D_{dc}(s)$ and $N_{ad}(s)/D_{dc}(s)$ and the plant output signal y .

15. A method comprising the steps of:

- a) generating a tracking error signal \tilde{y} that is a vector difference of a plant output signal y that is a function of states x existing in a plant, and a commanded output signal y_c ;
- b) generating a pseudo-control component signal v_{dc} based on a transfer function $N_{dc}(s)/D_{dc}(s)$ and the tracking error signal \tilde{y} ;
- c) generating a transformed signal \tilde{y}_{ad} based on a transfer function $N_{ad}(s)/D_{dc}(s)$ and the tracking error signal \tilde{y} ;
- d) controlling the plant with the pseudo-control component signal v_{dc} , the pseudo-control component signal v_{dc} controlling the plant based on an approximate linear model; and
- e) controlling the plant adaptively based on the transformed signal \tilde{y}_{ad} used for adaptive control of the plant.

16. A method as claimed in claim 15 further comprising the steps of:

- f) receiving a plant output signal y that is a function of states x existing in a plant;
- g) delaying the plant output signal y to produce a delayed signal y_d ;
- h) receiving a pseudo-control signal v used to control the plant;
- i) delaying the pseudo-control signal v to produce a delayed signal v_d ; and
- j) supplying the signals y , y_d , v , v_d to a neural network to generate an adaptive control signal v_{ad} to control the plant.

17. A method as claimed in claim 16 further comprising the steps of:

- k) filtering at least one basis function ϕ to generate a filtered basis function ϕ_f ;
- l) multiplying the filtered basis function ϕ_f by the transformed signal \tilde{y}_{ad} to produce an error signal δ ; and

22

m) modifying at least one connection weight W of the neural network based on the error signal δ .

18. A method as claimed in claim 17 further comprising the steps of:

- n) differentiating the plant output signal y r times to produce an r th derivative signal $y^{(r)}$ of the plant output signal y , r being the relative degree of the plant output signal;
- o) summing the r th derivative signal, the pseudo-control component signal v_{dc} , and the adaptive control signal v_{ad} to generate a pseudo-control signal v ; and
- p) generating a command control signal δ_c based on the pseudo-control signal v and the plant output signal y by model inversion.

19. A method comprising the steps of:

- a) receiving a plant output signal y that is a function of states existing in a plant;
- b) delaying the plant output signal y to produce a delayed signal y_d ;
- c) receiving a pseudo-control signal v used to control the plant;
- d) delaying the pseudo-control signal v to produce a delayed signal v_d ; and
- e) supplying the signals y , y_d , v , v_d to a neural network to generate an adaptive control signal v_{ad} to assist a linear controller in controlling the plant.

20. A method as claimed in claim 19 further comprising the steps of:

- f) filtering at least one basis function ϕ to generate a filtered basis function ϕ_f ;
- g) multiplying the filtered basis function ϕ_f by the transformed signal \tilde{y}_{ad} to produce an error signal δ ; and
- h) modifying at least one connection weight W of the neural network based on the error signal δ .

* * * * *