

(12) **United States Patent**  
**Wang et al.**

(10) **Patent No.:** **US 7,412,637 B2**  
(45) **Date of Patent:** **Aug. 12, 2008**

(54) **METHOD AND APPARATUS FOR BROADCASTING TEST PATTERNS IN A SCAN BASED INTEGRATED CIRCUIT**

OTHER PUBLICATIONS

(75) Inventors: **Laung-Terng (L.-T.) Wang**, Sunnyvale, CA (US); **Boryau (Jack) Sheu**, San Jose, CA (US); **Zhigang Jiang**, San Jose, CA (US); **Zhigang Wang**, Sunnyvale, CA (US); **Shianling Wu**, Princeton Junction, NJ (US)

I. Bayraktaroglu, and A. Orailoglu, "Test Volume and Application Time Reduction Through Scan Chain Concealment," Proc., IEEE 38<sup>th</sup> Design Automation Conf., pp. 151-155, 2001.

(Continued)

*Primary Examiner*—James C Kerveros  
(74) *Attorney, Agent, or Firm*—Bacon & Thomas, PLLC

(73) Assignee: **Syntest Technologies, Inc.**, Sunnyvale, CA (US)

(57) **ABSTRACT**

(\*) Notice: Subject to any disclaimer, the term of this patent is extended or adjusted under 35 U.S.C. 154(b) by 254 days.

A broadcaster, system, and method for reducing test data volume and test application time in an ATE (automatic test equipment) in a scan-based integrated circuit. The scan-based integrated circuit contains multiple scan chains, each scan chain comprising multiple scan cells coupled in series. The broadcaster is a combinational logic network coupled to an optional virtual scan controller and an optional scan connector. The virtual scan controller controls the operation of the broadcaster. The system transmits virtual scan patterns stored in the ATE and generates broadcast scan patterns through the broadcaster for testing manufacturing faults in the scan-based integrated circuit. The number of scan chains that can be supported by the ATE is significantly increased. Methods are further proposed to reorder scan cells in selected scan chains, to generate the broadcast scan patterns and virtual scan patterns, and to synthesize the broadcaster and a compactor in the scan-based integrated circuit.

(21) Appl. No.: **11/348,519**

(22) Filed: **Feb. 7, 2006**

(65) **Prior Publication Data**

US 2006/0242502 A1 Oct. 26, 2006

**Related U.S. Application Data**

(63) Continuation-in-part of application No. 10/339,667, filed on Jan. 10, 2003.

(51) **Int. Cl.**  
**G01R 31/28** (2006.01)

(52) **U.S. Cl.** ..... **714/729**

(58) **Field of Classification Search** ..... 714/726,  
714/729, 733, 738

See application file for complete search history.

(56) **References Cited**

U.S. PATENT DOCUMENTS

4,503,537 A 3/1985 McAnney  
5,701,309 A 12/1997 Gearhardt et al. .... 371/25.1

The scan architecture used can also be random access scan based, where the integrated circuit comprises an array of random access scan (RAS) cells that are randomly and uniquely addressable. In random access scan, test patterns can be applied by selectively updating RAS cells and test responses can be observed through a direct read-out process. Eliminating the shifting process inherent in serial scan, random access scan produces much lower test power dissipation than serial scan.

(Continued)

**86 Claims, 33 Drawing Sheets**

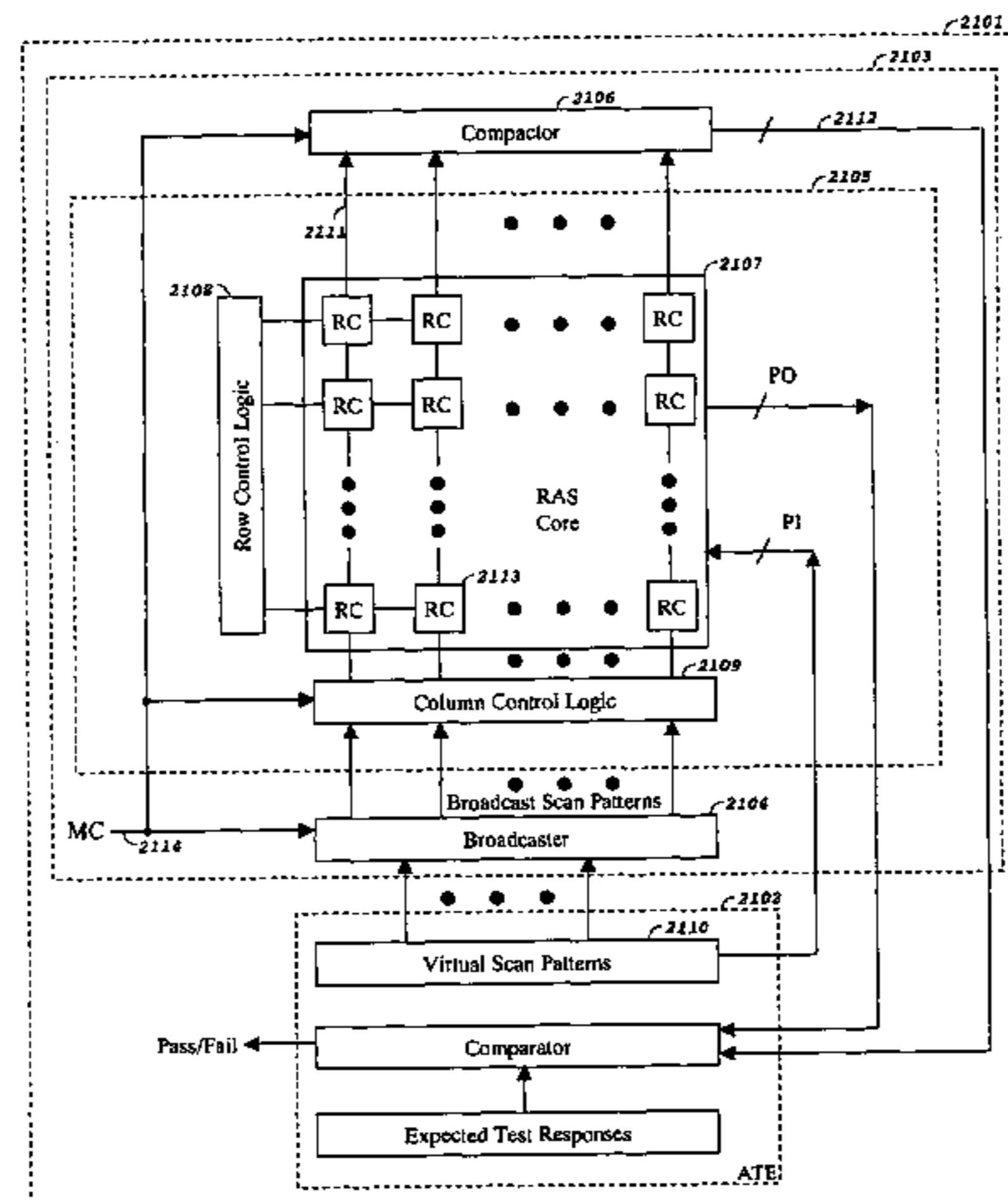

## U.S. PATENT DOCUMENTS

5,923,836	A	7/1999	Barch et al. ....	395/183.09
5,991,909	A *	11/1999	Rajski et al. ....	714/729
6,256,760	B1	7/2001	Carron et al. ....	714/726
6,327,685	B1	12/2001	Koprowski et al. ....	714/733
6,327,687	B1	12/2001	Rajski et al.	
6,543,020	B2 *	4/2003	Rajski et al. ....	714/738
6,611,933	B1	8/2003	Koenemann et al.	
6,684,358	B1 *	1/2004	Rajski et al. ....	714/739

## OTHER PUBLICATIONS

I. Hamzaoglu, and J.H. Patel, "Reducing Test Application Time for Full Scan Embedded Cores," Proc., IEEE 29<sup>th</sup> Fault-Tolerant Computing Symposium, pp. 260-267, 1999.

S. Hellebrand, J. Rajski, S. Tarnick, S. Venkataraman, and B. Curtis, "Built-in Test for Circuits with Scan Based Reseeding of Multiple Polynomial Linear Feedback Shift Registers", *IEEE Transactions on Computers*, vol. C-44, pp. 223-233, Feb. 1995.

A. Jas, B. Pouya, and N. Touba, "Virtual Scan Chains: A Means for Reducing Scan Length in Cores," Proc., IEEE VLSI Test Symposium, pp. 73-78, Apr. 2000.

B. Koenemann, "LFSR-Coded Test Patterns for Scan Designs", Proc., European Test Conf., pp. 237-242, 1991.

K.-J. Lee, J.-J. Chen, and C.-H. Huang, "Broadcasting Test Patterns to Multiple Circuits", *IEEE Transactions on Computer-Aided Design of Integrated Circuits and Systems*, vol. 18, No. 12, pp. 1793-1802, Dec. 1999.

A.R. Pandey, and J.H. Patel, "An Incremental Algorithm for Test Generation in Illinois Scan Architecture Based Designs," Proc., IEEE 2002 Design, Automation and Test in Europe (DATE), pp. 368-375, 2002.

J. Rajski, J. Tyszer, and N. Zacharia, "Test Data Decompression for Multiple Scan Designs with Boundary Scan", *IEEE Transactions on Computers*, vol. 47, No. 11, Nov. 1998.

H. Ando, "Testing VLSI with Random Access Scan," *Proc. of COMPCON*, pp. 50-52, Feb. 1980.

D.H. Baik et al, "Progressive Random Access Scan: a Simultaneous-Solution to Test Power, Test Data Volume and Test Time," *Proc. International Test Conf.*, paper 15.2, 2005.

B. Bhattacharya et al, "Double-Tree Scan: a Novel Low-power Scan-path Architecture," *Proc. International Test Conf.*, pp. 470-479, Oct. 2003.

S. Kajihara et al, "Test Vector Modification for Power Reduction During Scan Testing," *Proc. In VLSI Test Symposium*, pp. 160-165, May 2002.

A.S. Mudlapur et al, "A Random Access Scan Architecture to Reduce Hardware Overhead," *Proc. Int'l Test Conf.*, Paper 15.1 (9 pages), Nov. 2005.

S. Wang et al, "ATPG for Heat Dissipation Minimization During Scan Testing," *Proc. European Design Automation Conf.*, pp. 614-619, Jun. 1997.

X. Wen et al, "On Low-Capture-Power Test Generation for Scan Testing," *Proc. In VLSI Test Symposium*, p. 265-270, 2005.

\* cited by examiner

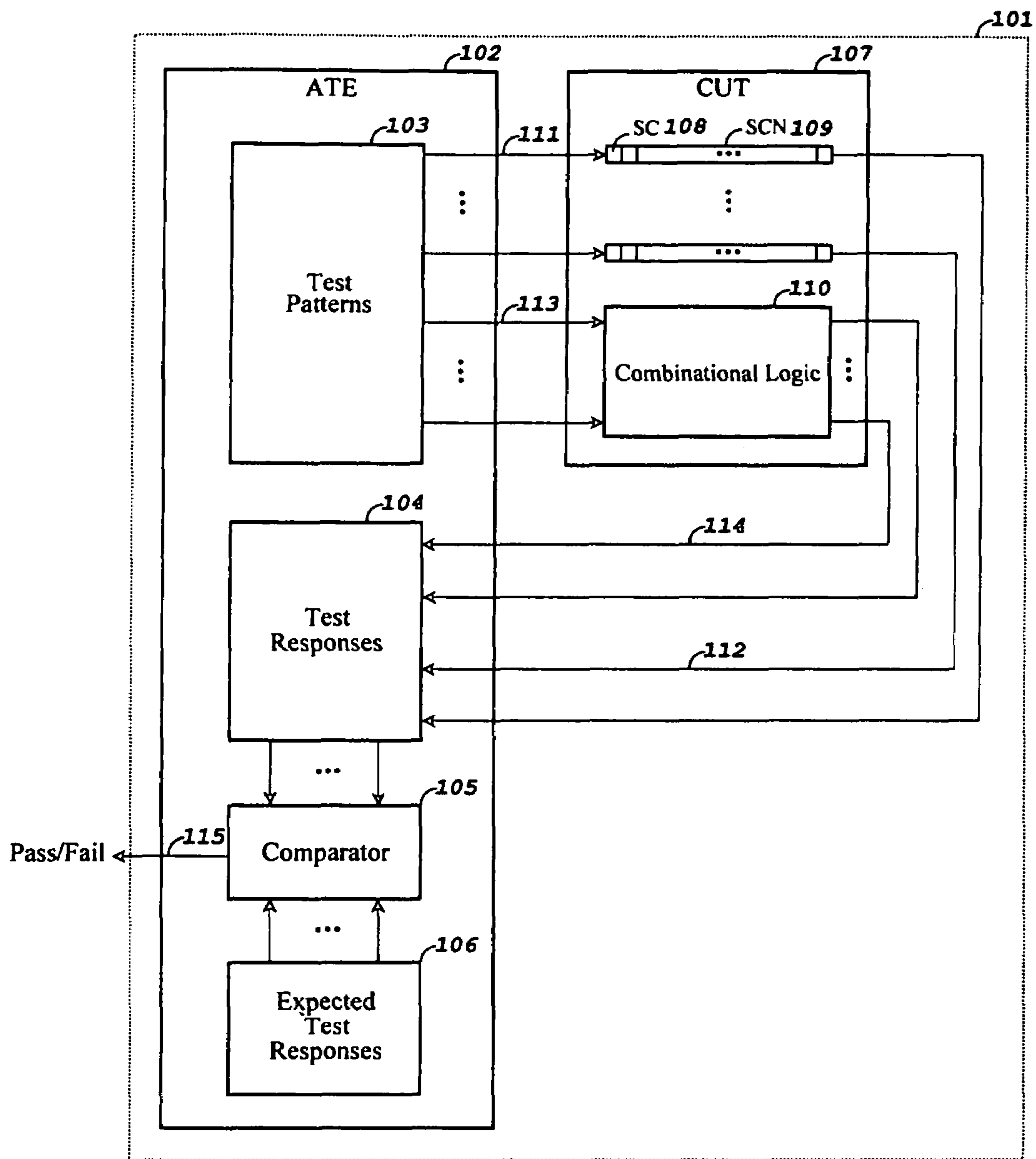

PRIOR ART  
FIG. 1

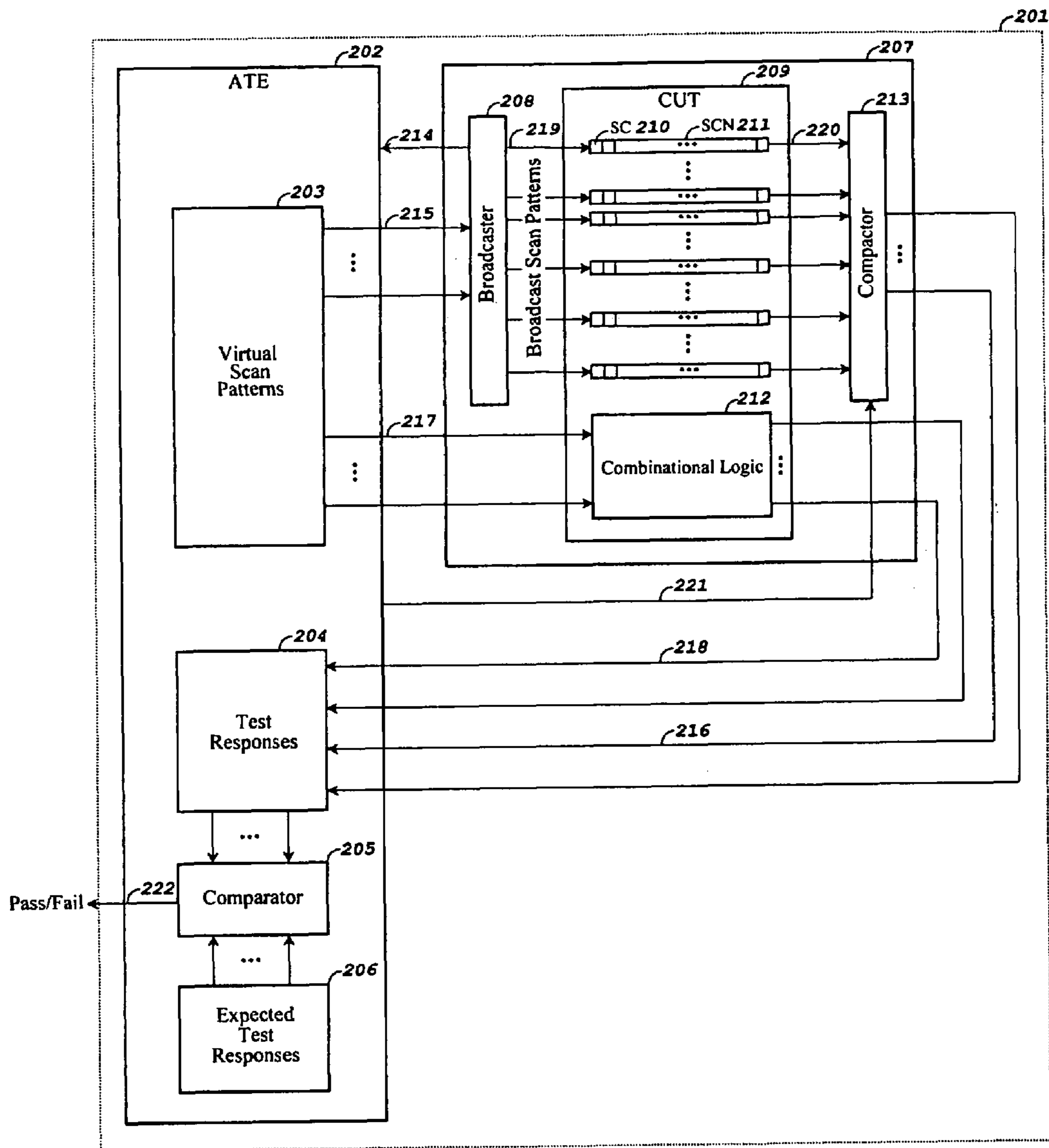
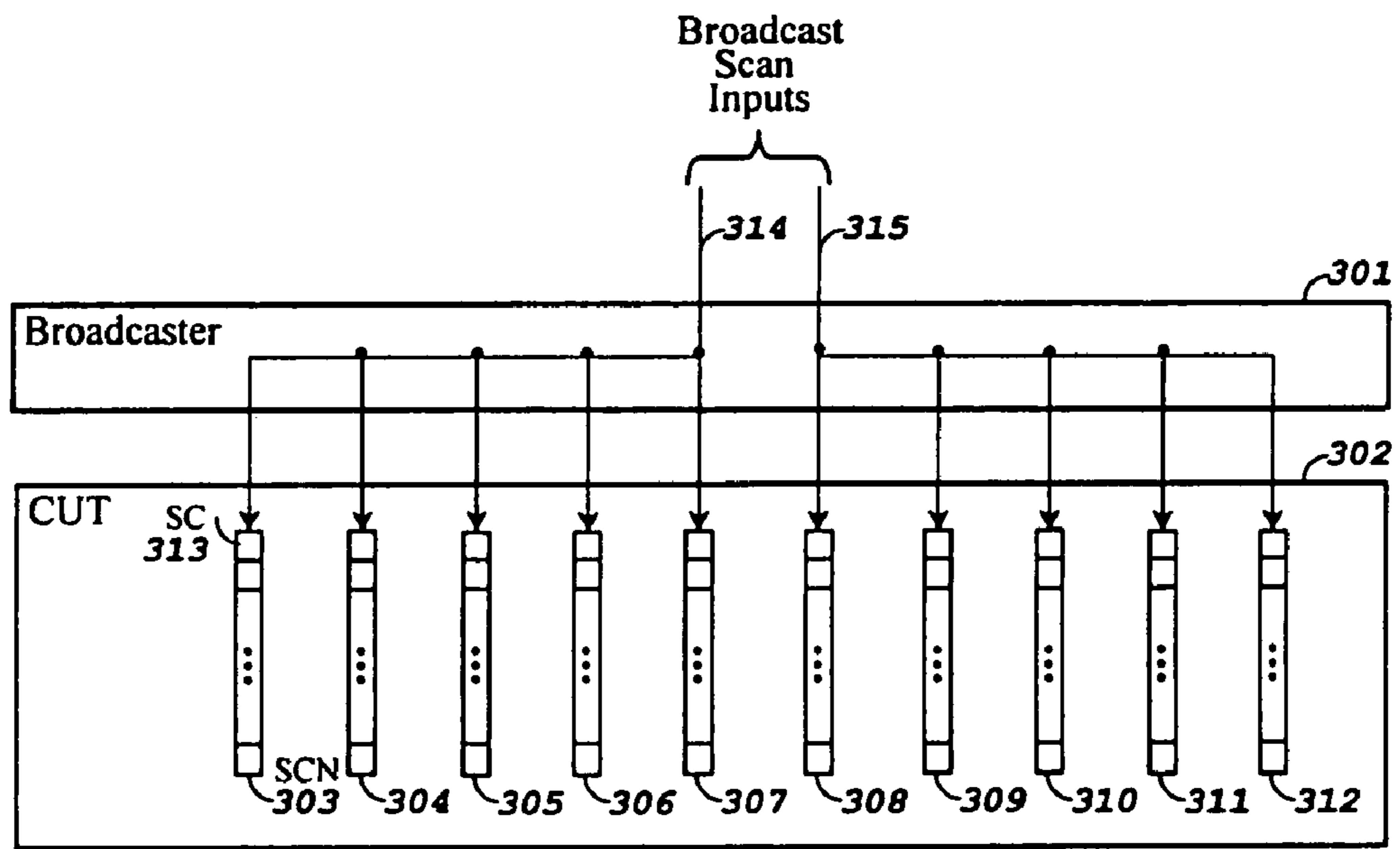

FIG. 2



PRIOR ART  
FIG. 3

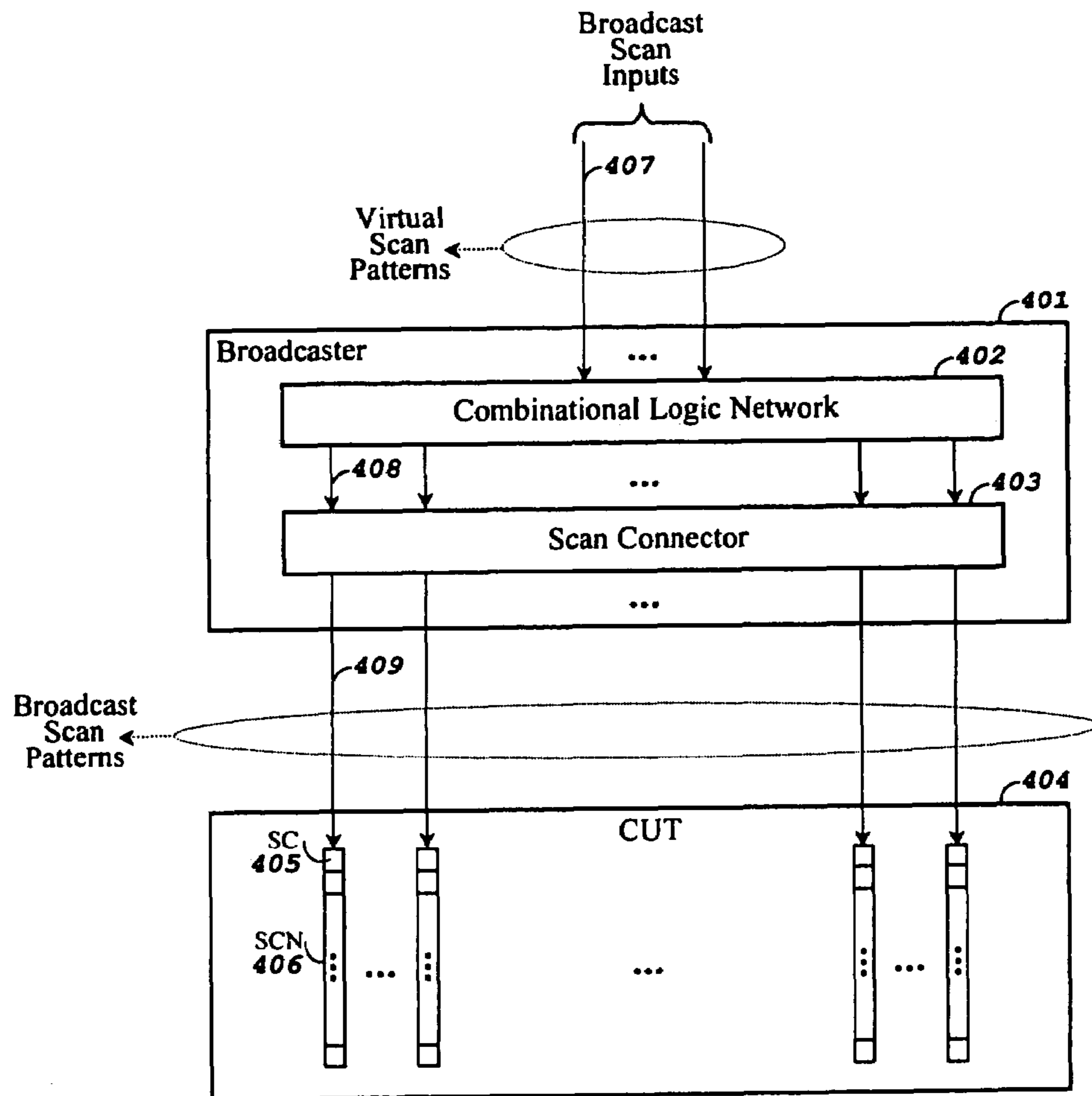

FIG. 4

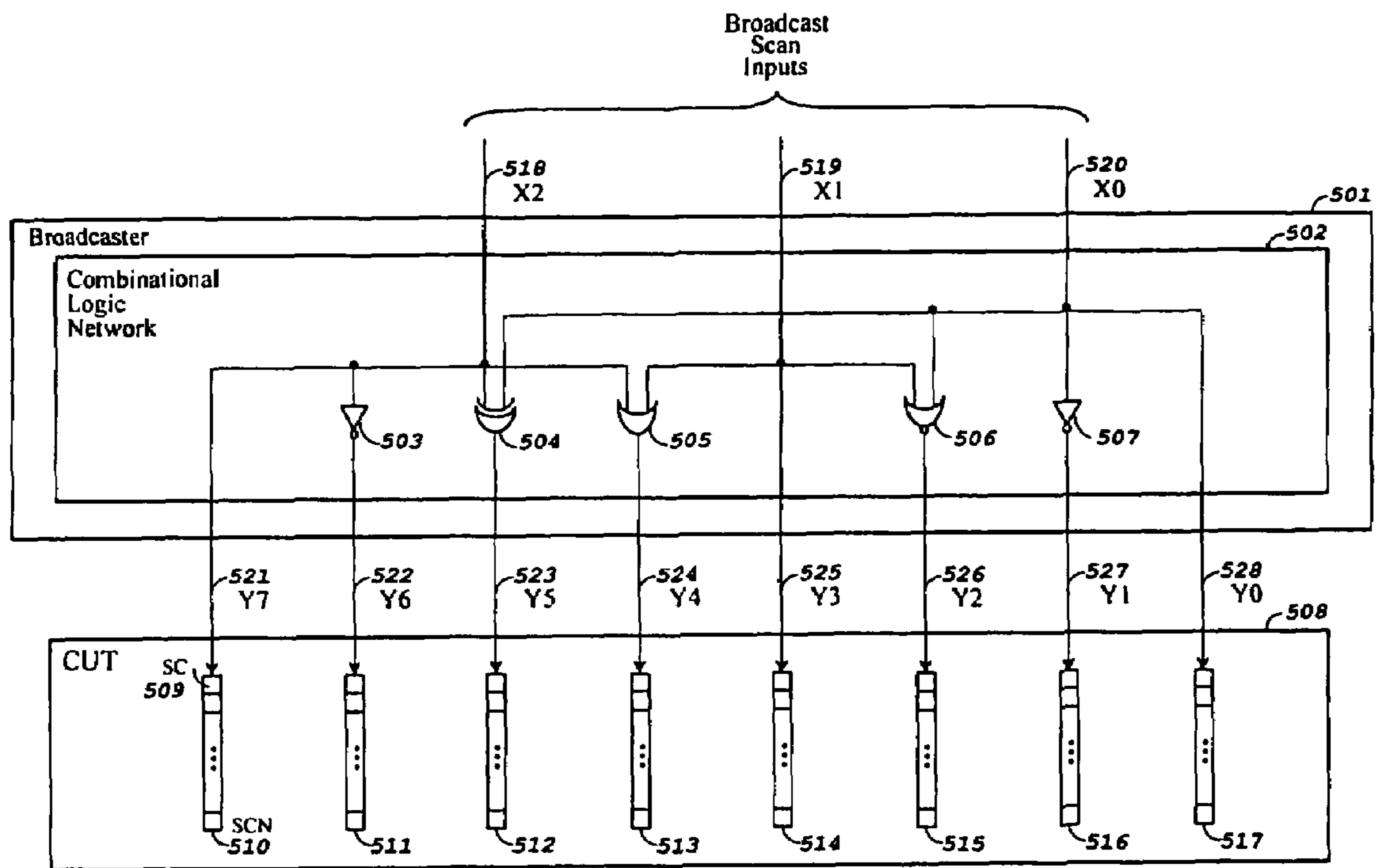

FIG. 5A

531

Broadcast Scan Inputs			Input Constraints							
X2	X1	X0	Y7	Y6	Y5	Y4	Y3	Y2	Y1	Y0
0	0	0	0	1	0	0	0	1	1	0
0	0	1	0	1	1	0	0	0	0	1
0	1	0	0	1	0	1	1	0	1	0
0	1	1	0	1	1	1	1	0	0	1
1	0	0	1	0	1	1	0	0	1	0
1	0	1	1	0	0	1	0	0	0	1
1	1	0	1	0	1	1	1	0	1	0
1	1	1	1	0	0	1	1	0	0	1

FIG. 5B



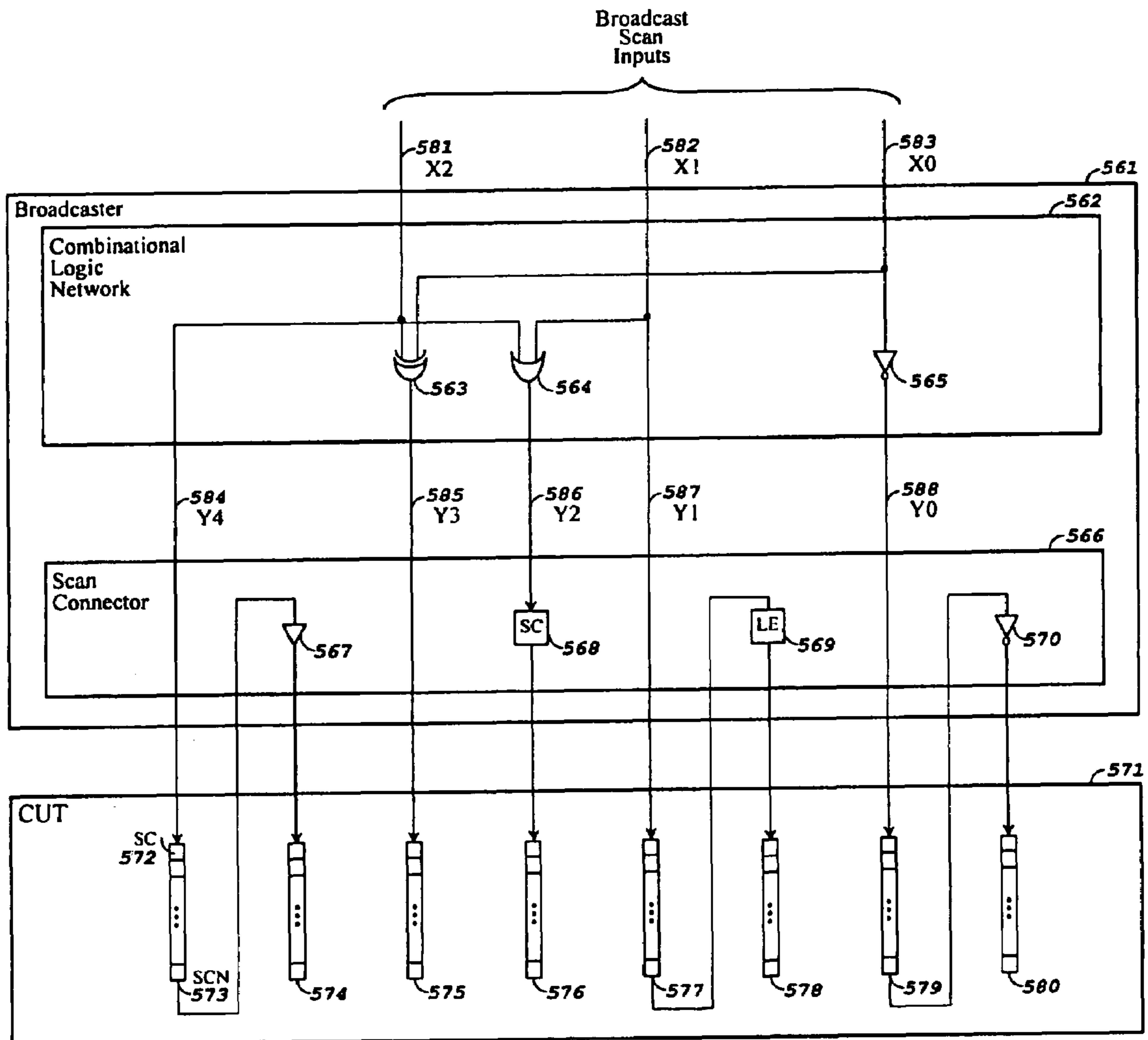

FIG. 5C

591

Broadcast Scan Inputs			Input Constraints				
X2	X1	X0	Y4	Y3	Y2	Y1	Y0
0	0	0	0	0	0	0	1
0	0	1	0	1	0	0	0
0	1	0	0	0	1	1	1
0	1	1	0	1	1	1	0
1	0	0	1	1	1	0	1
1	0	1	1	0	1	0	0
1	1	0	1	1	1	1	1
1	1	1	1	0	1	1	0

FIG. 5D

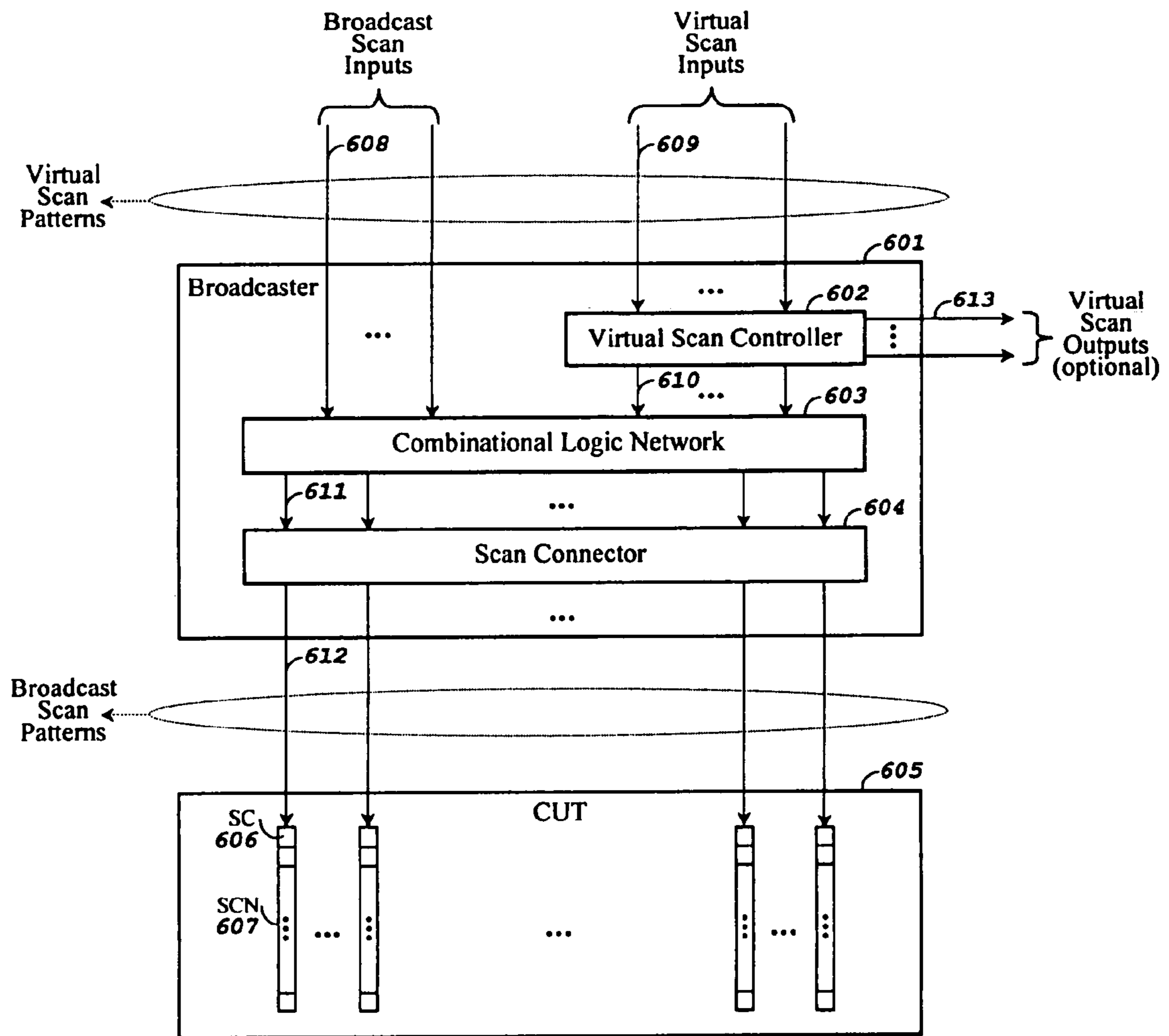

FIG. 6

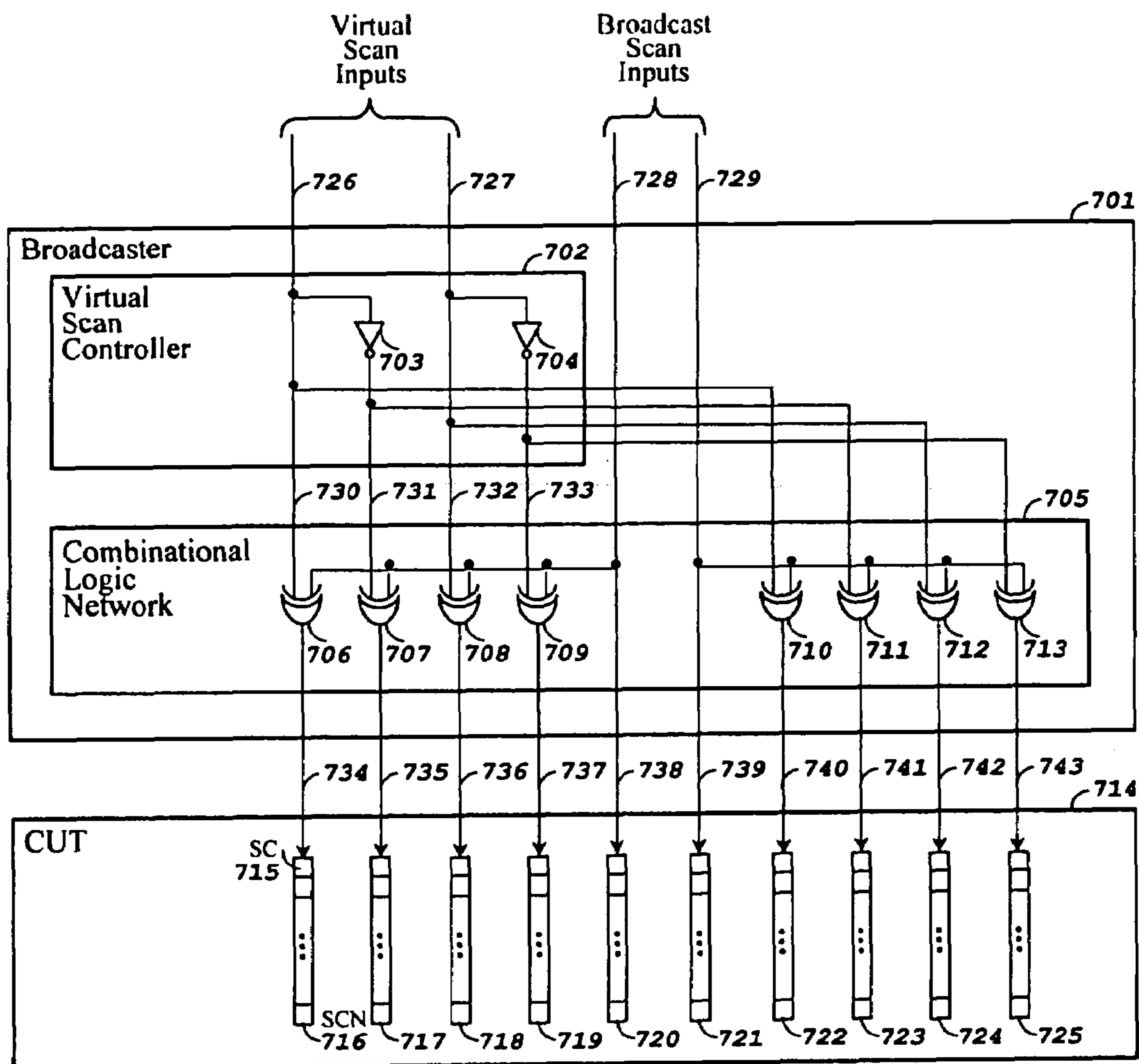

FIG. 7

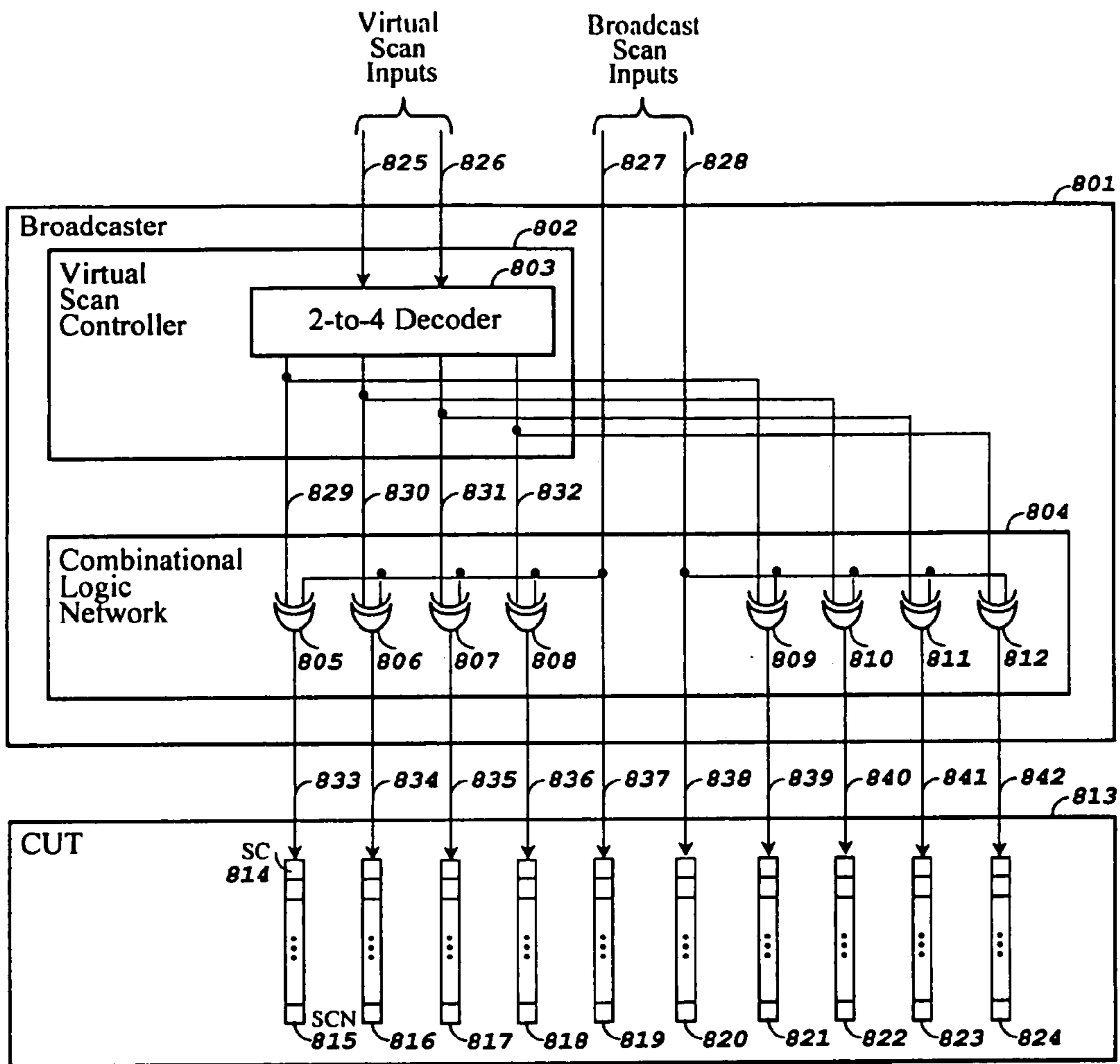

FIG. 8

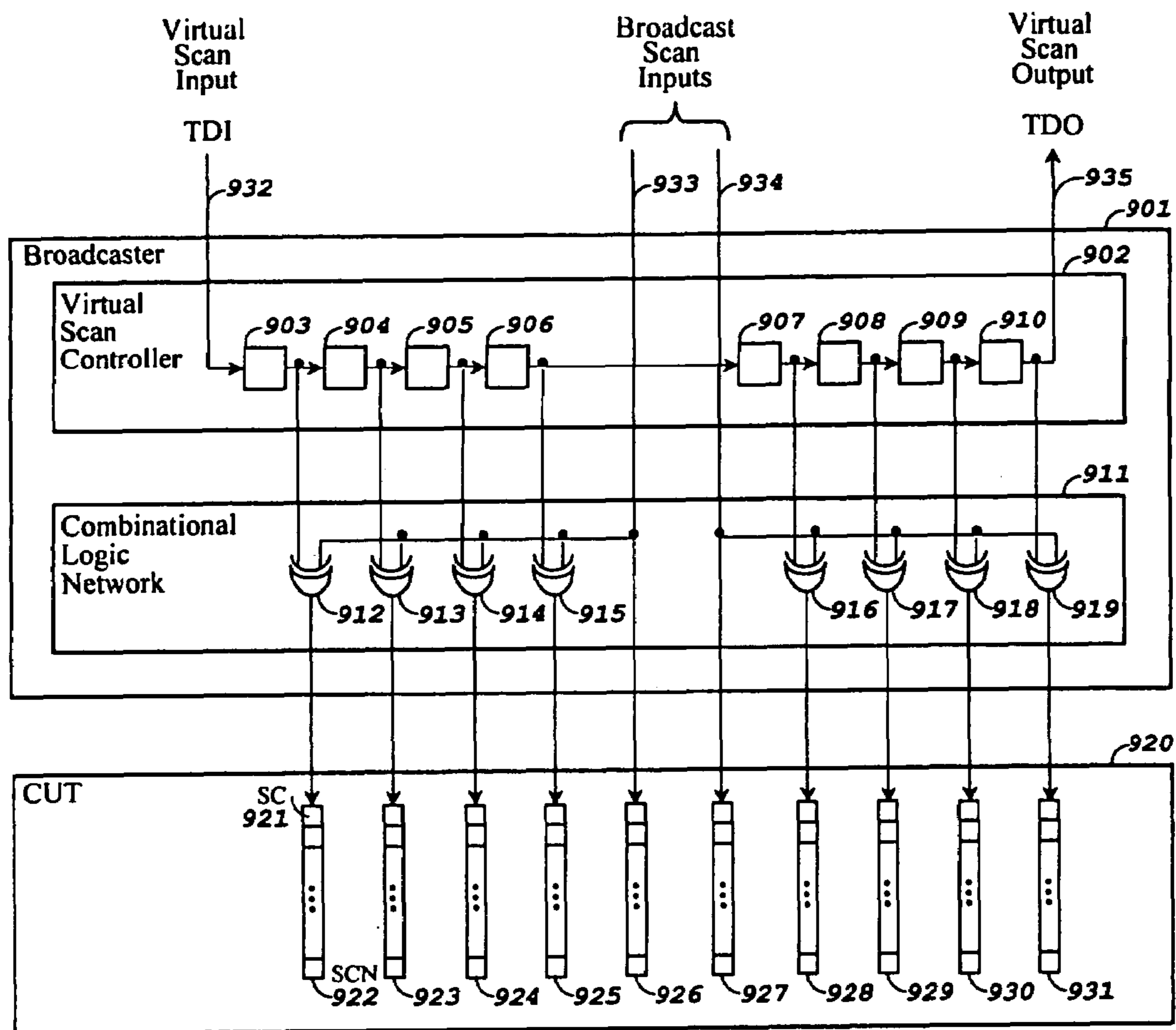

FIG. 9

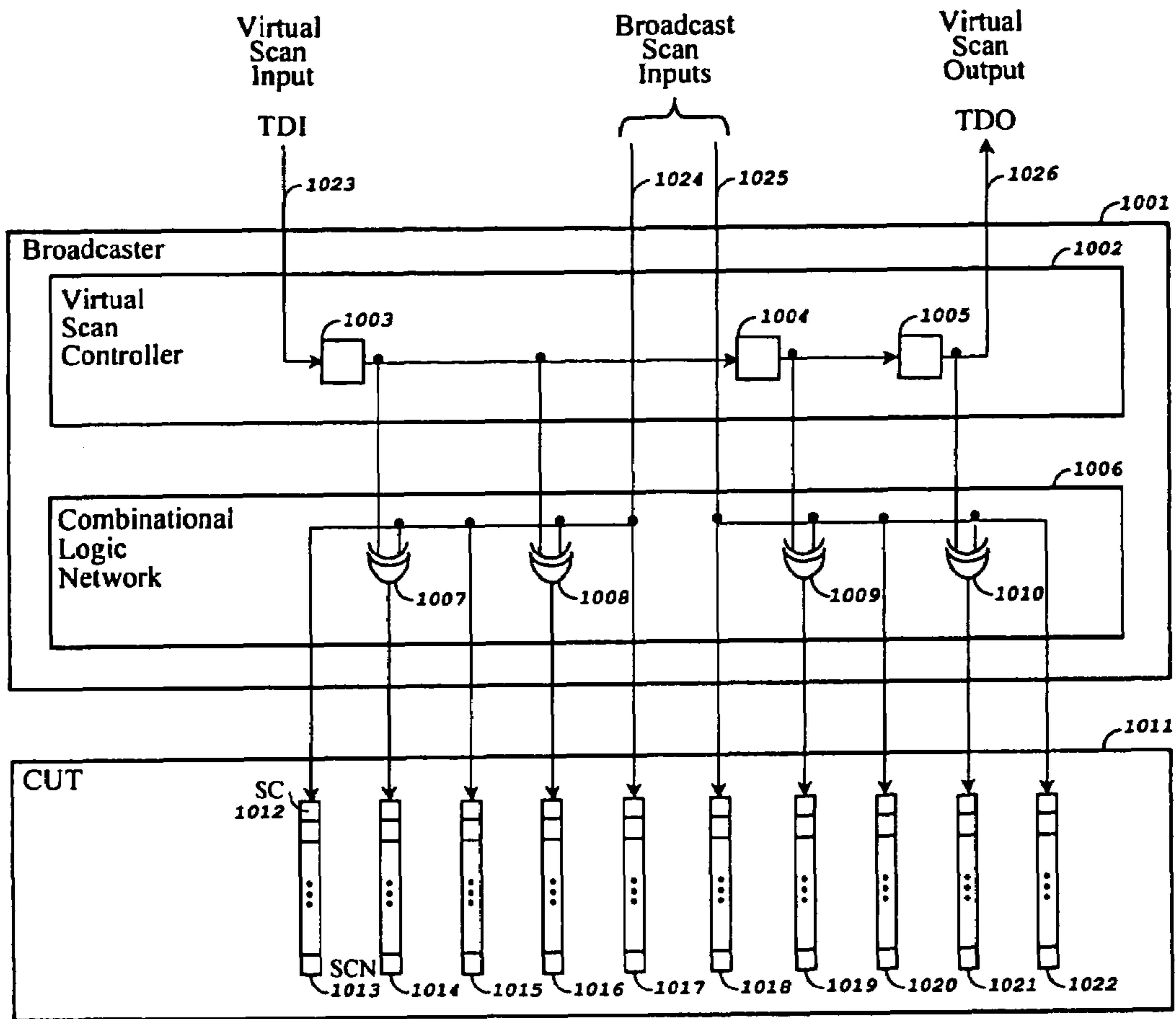

FIG. 10

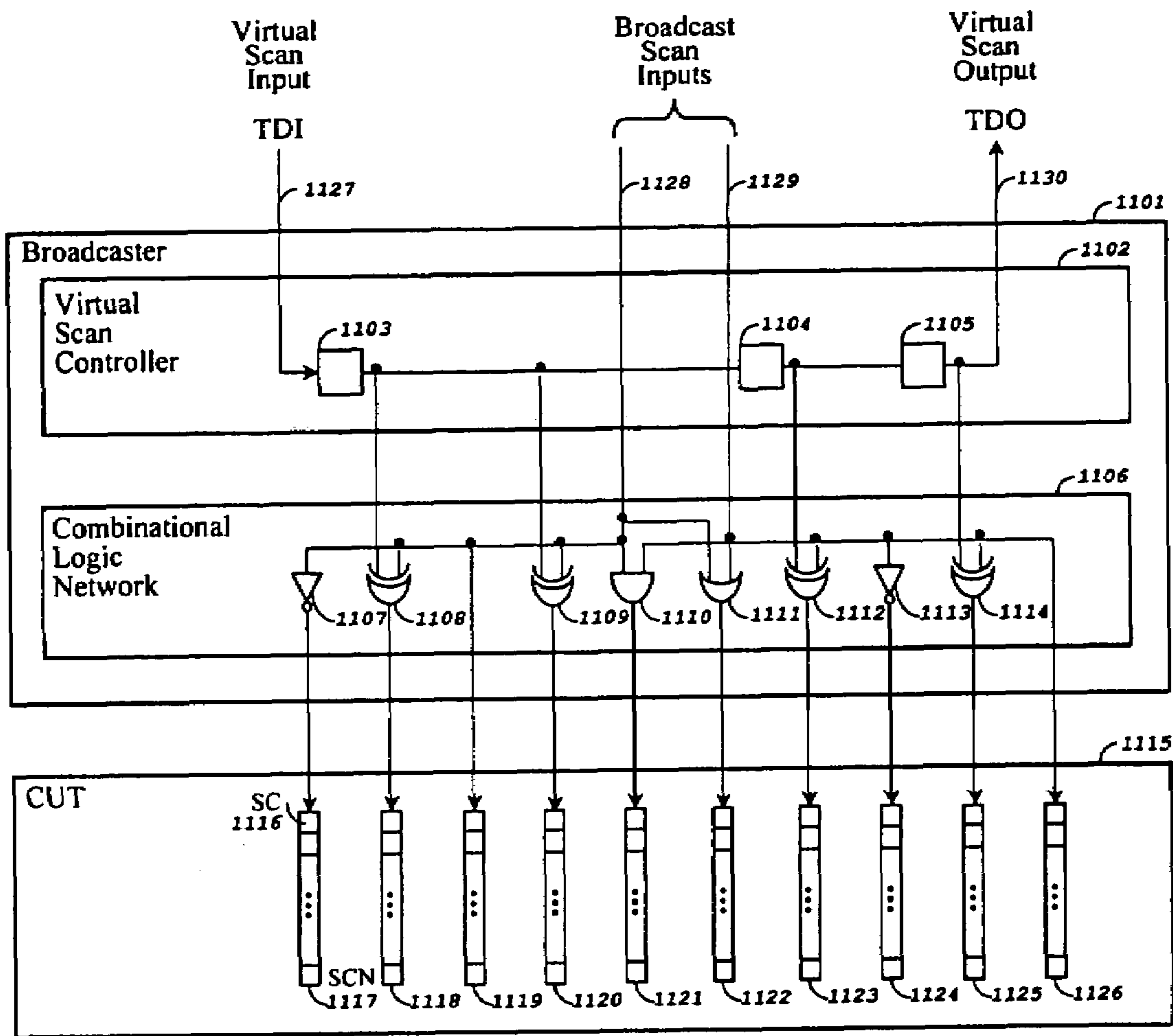

FIG. 11



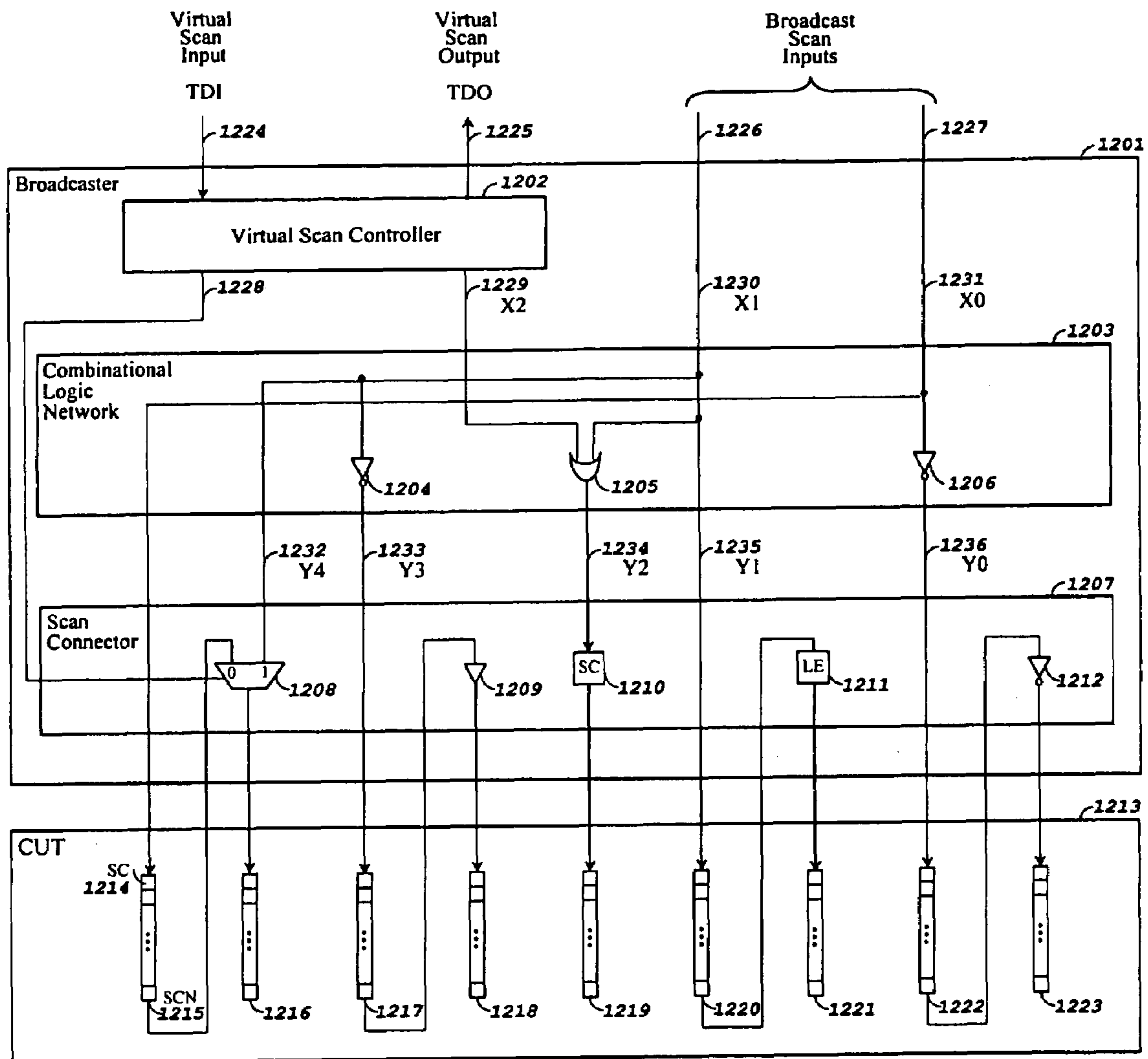

FIG. 12

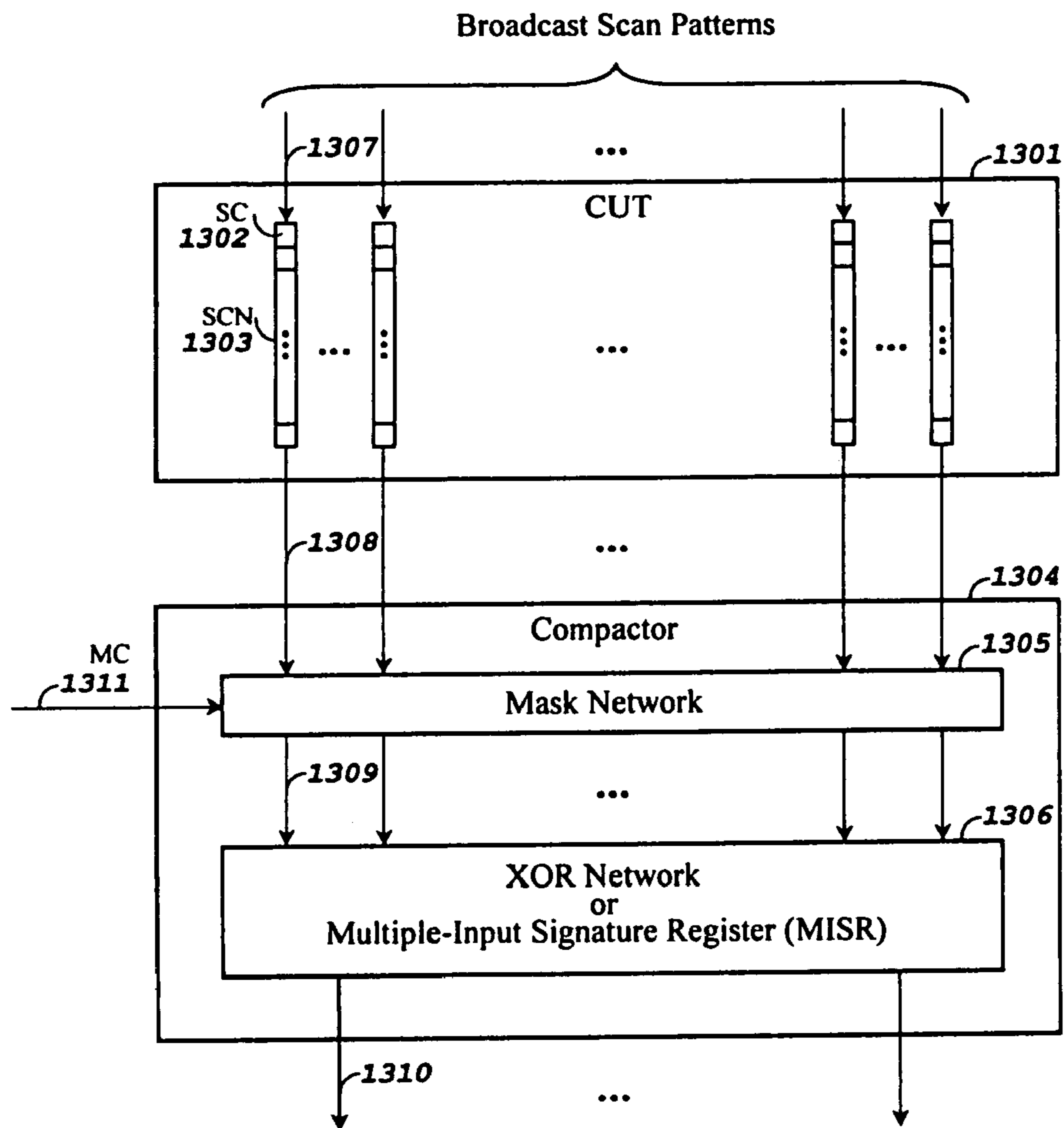

FIG. 13

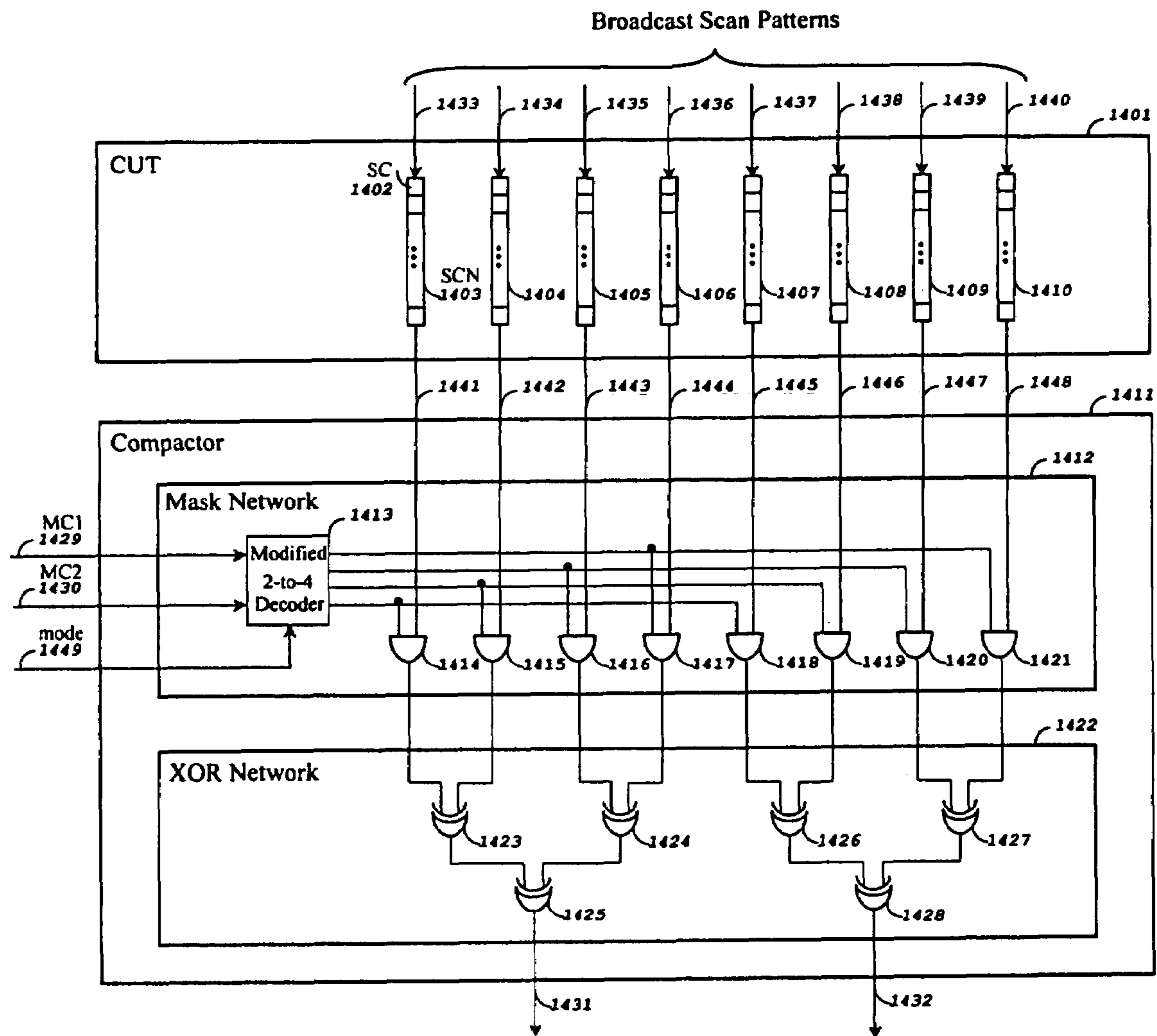

FIG. 14

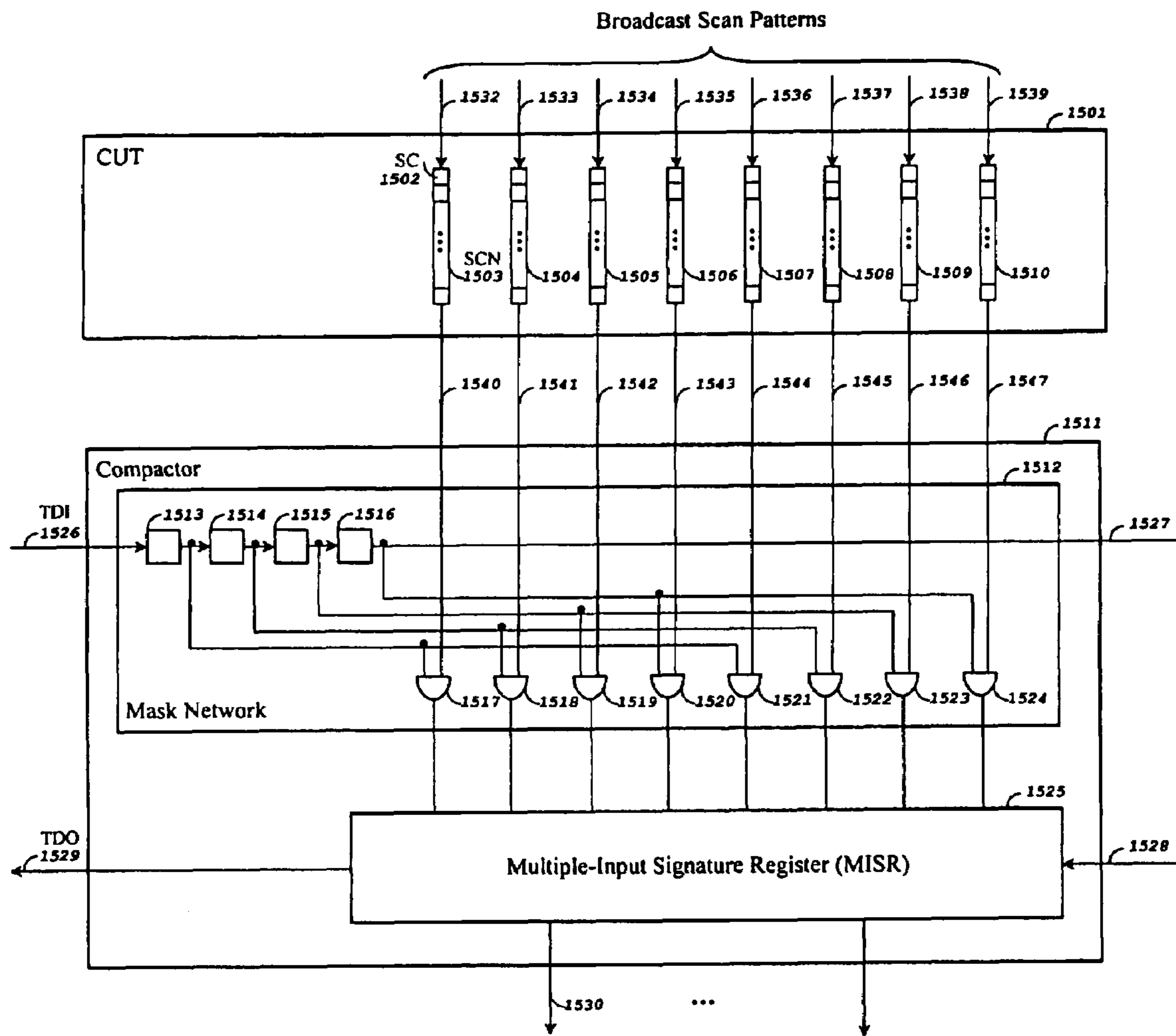

FIG. 15

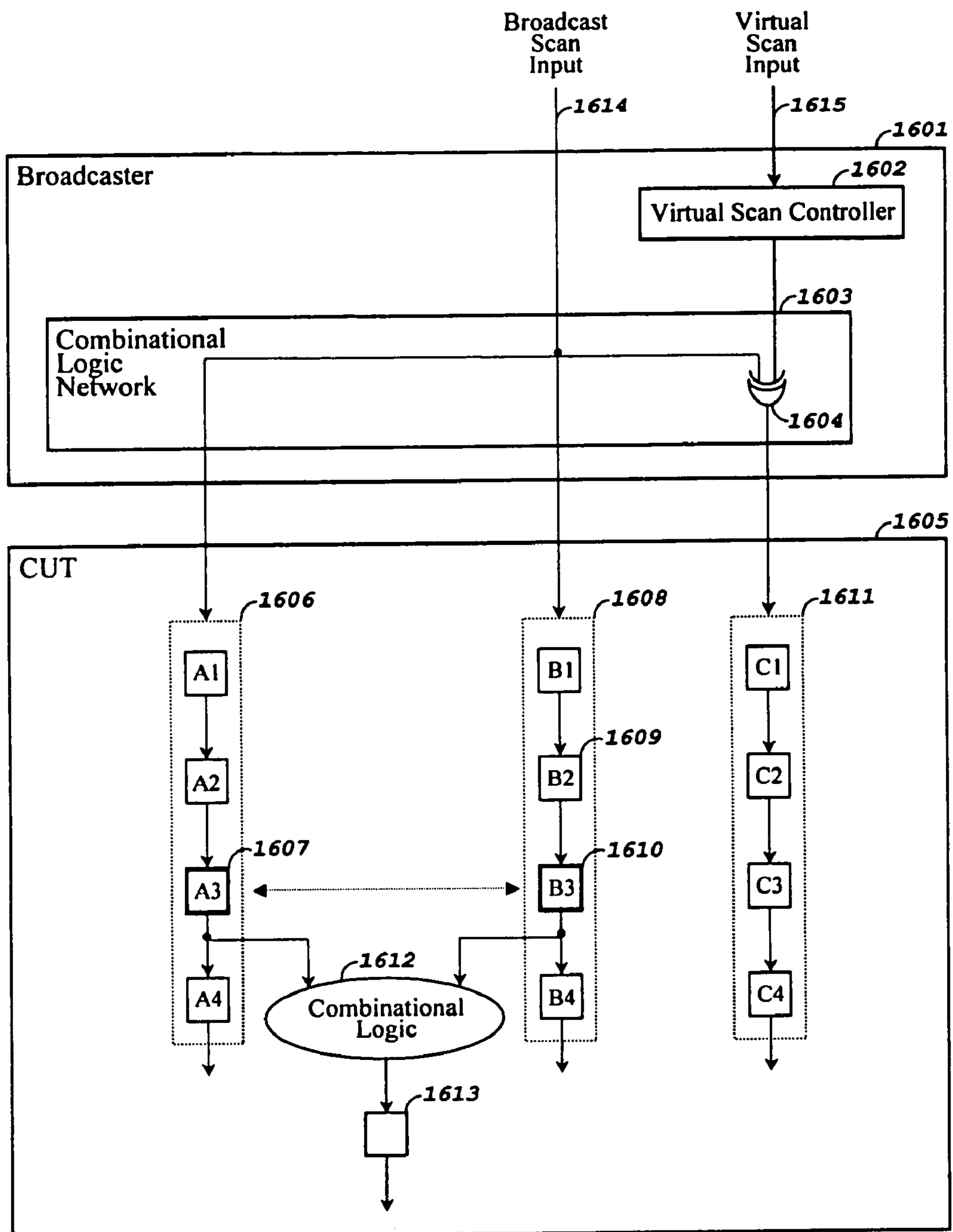

FIG. 16A

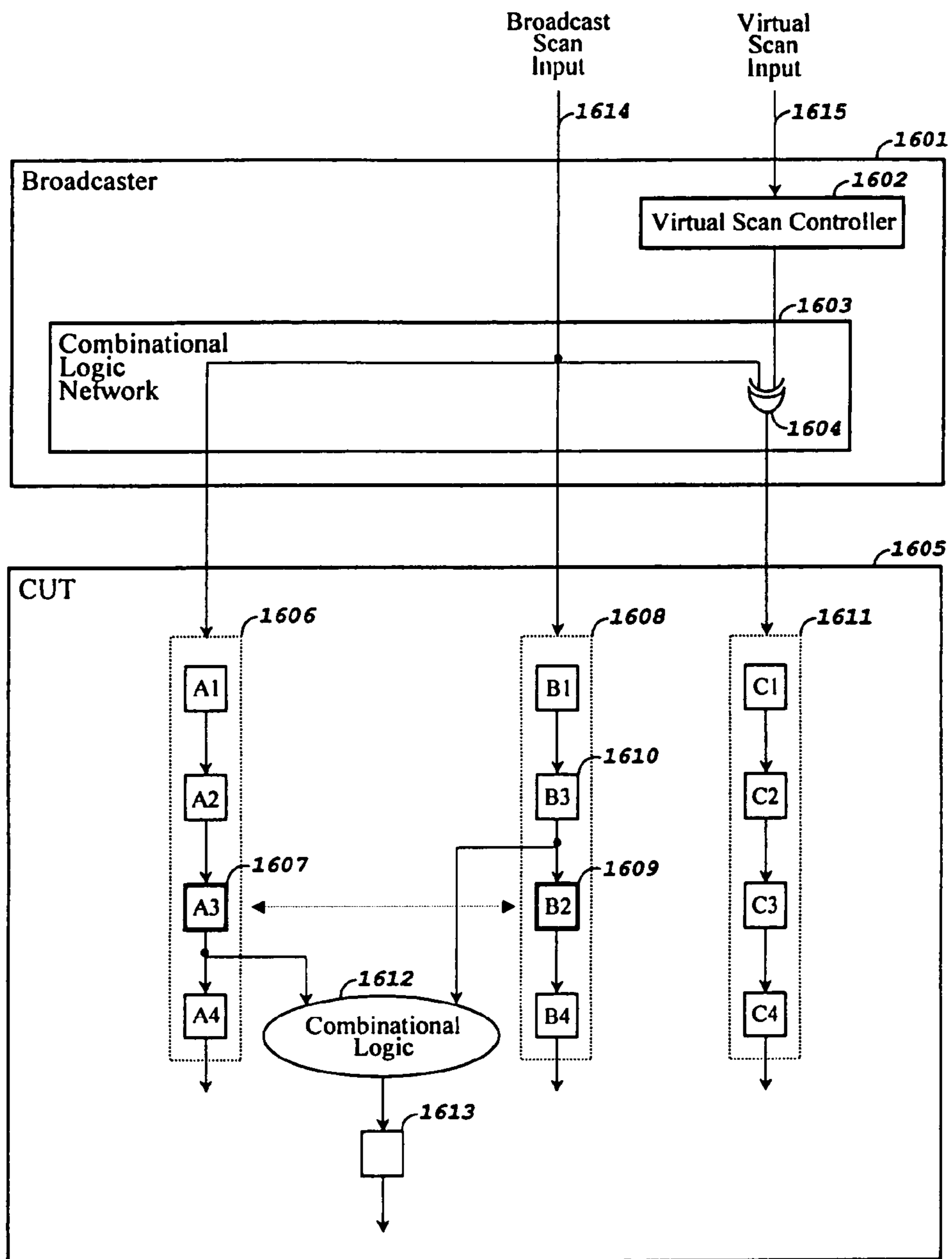

FIG. 16B

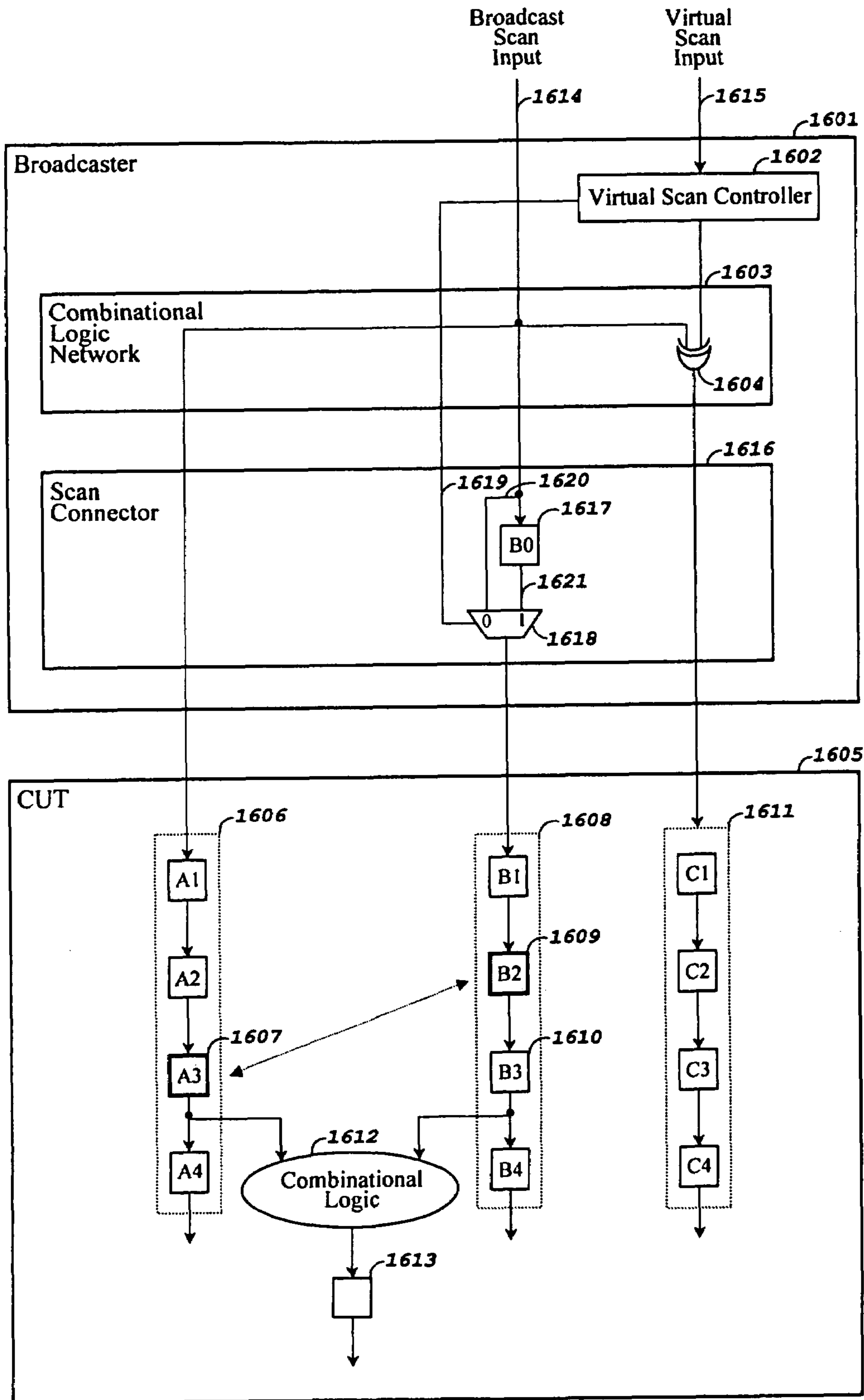

FIG. 16C

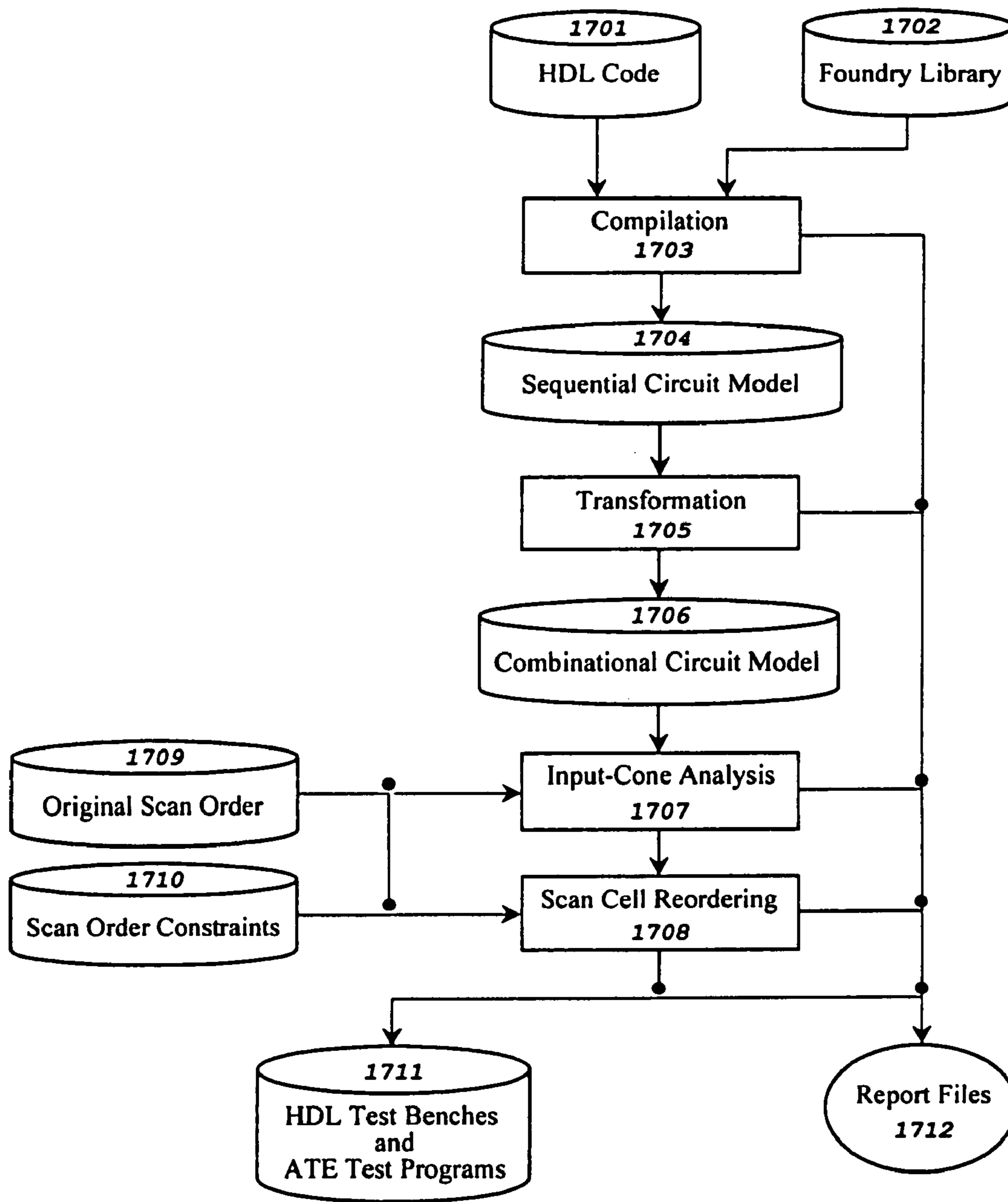

FIG. 17



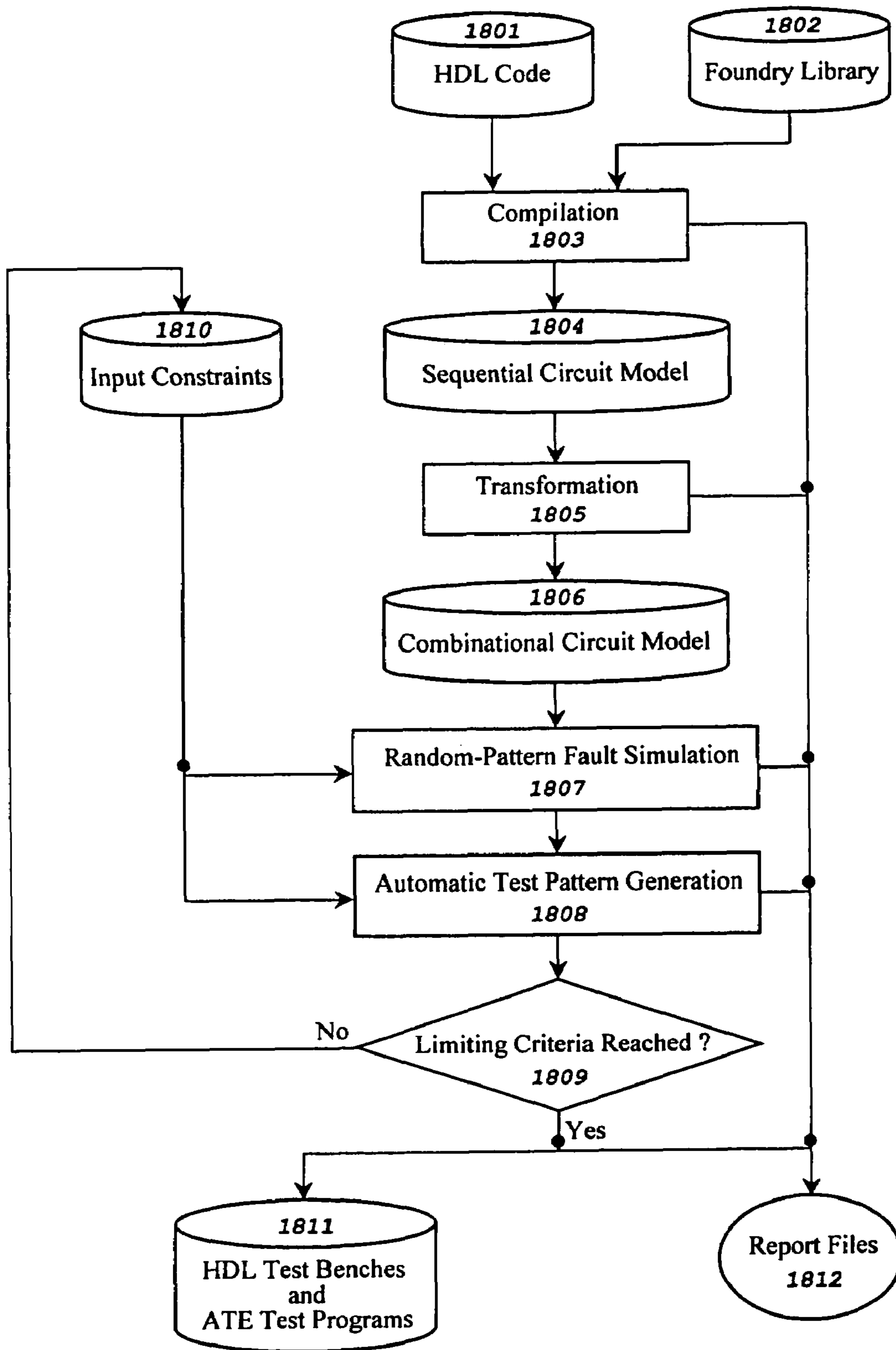

FIG. 18

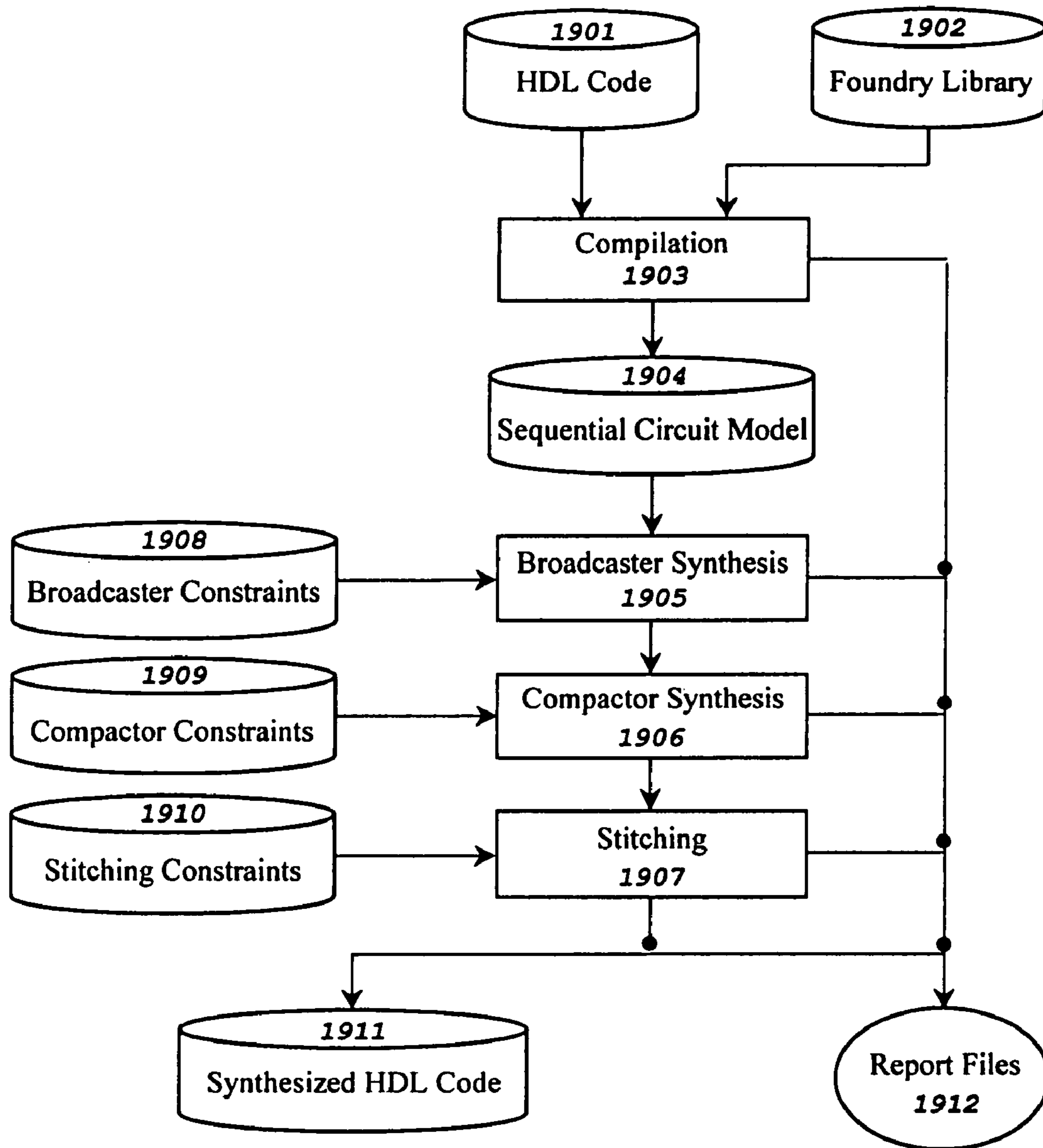

FIG. 19

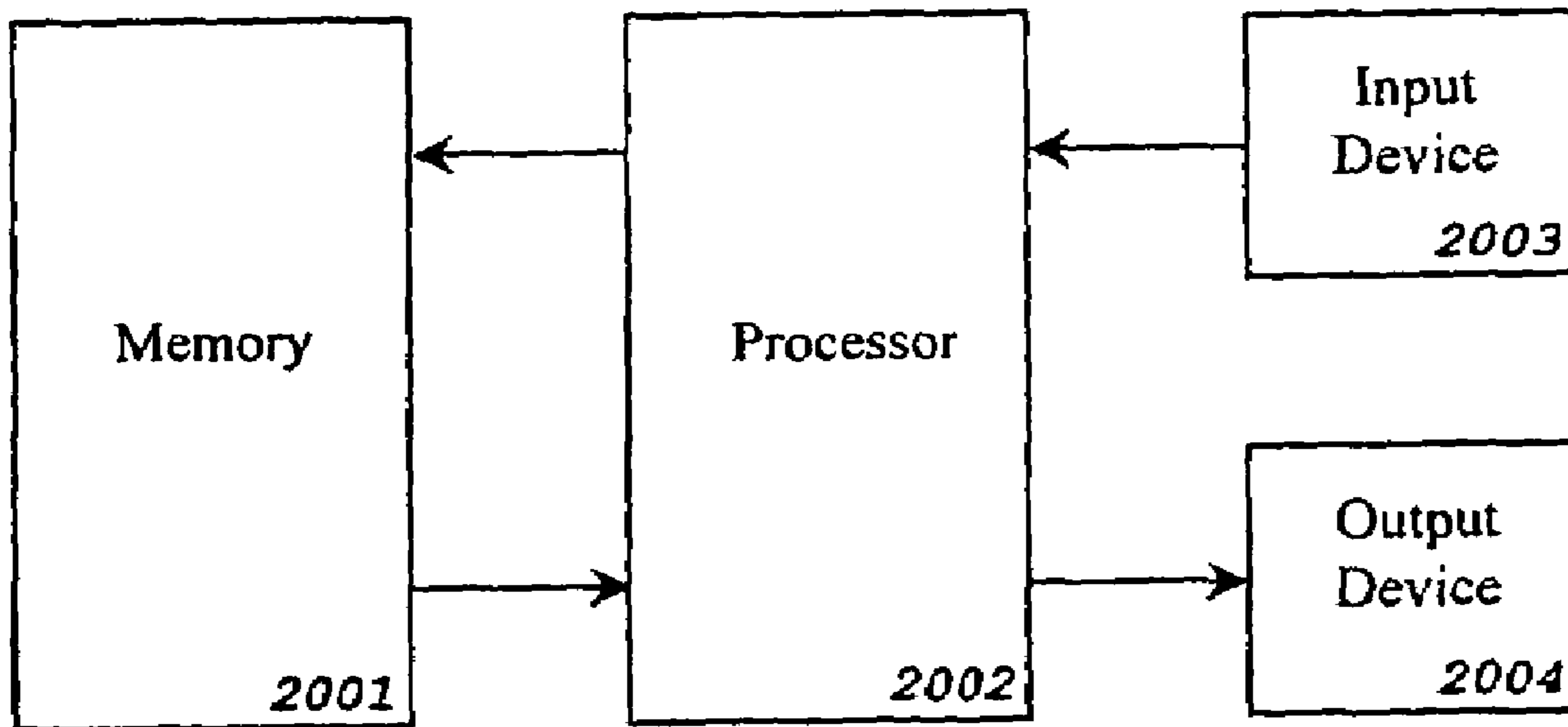

FIG. 20

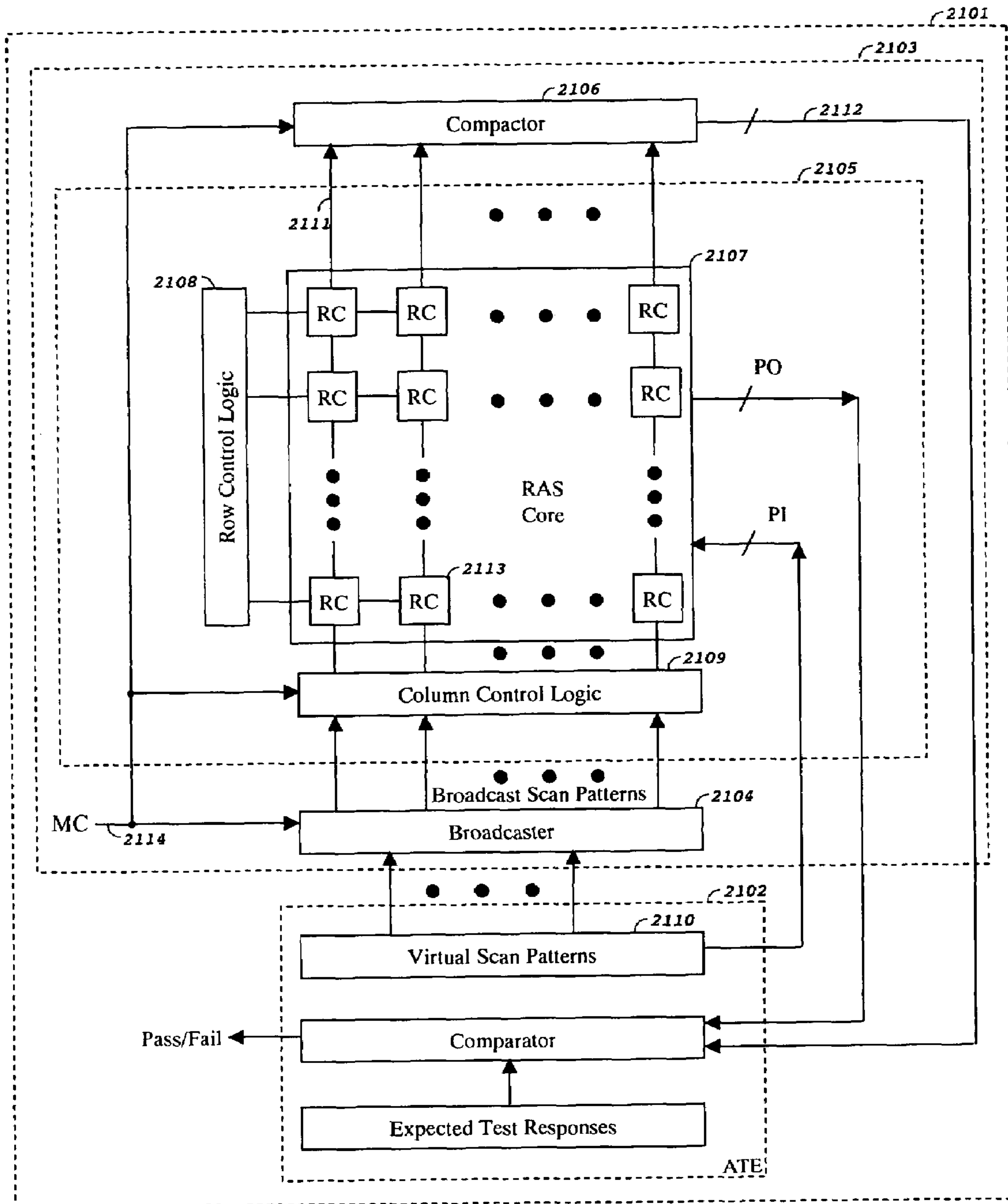

FIG. 21

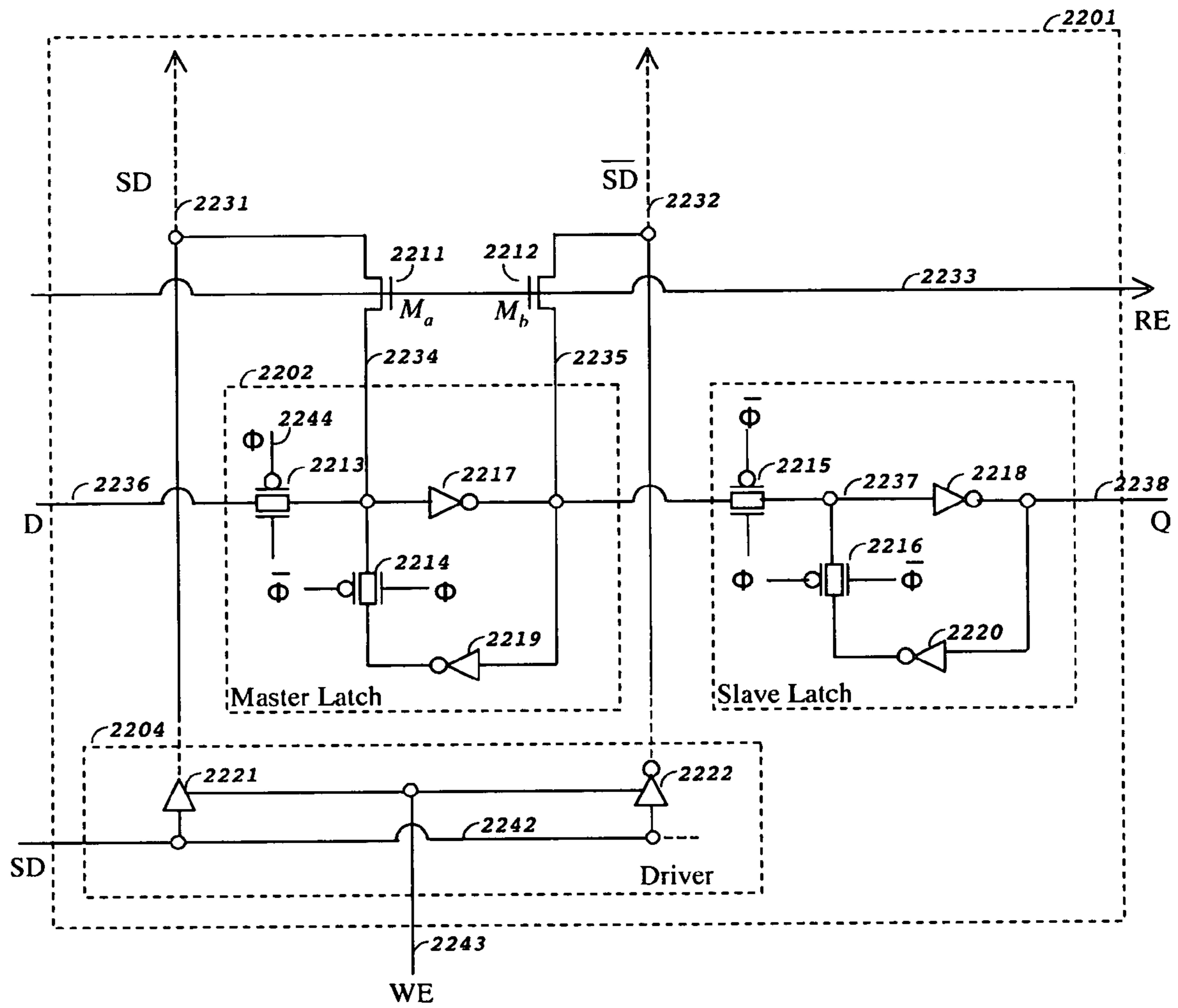

FIG. 22

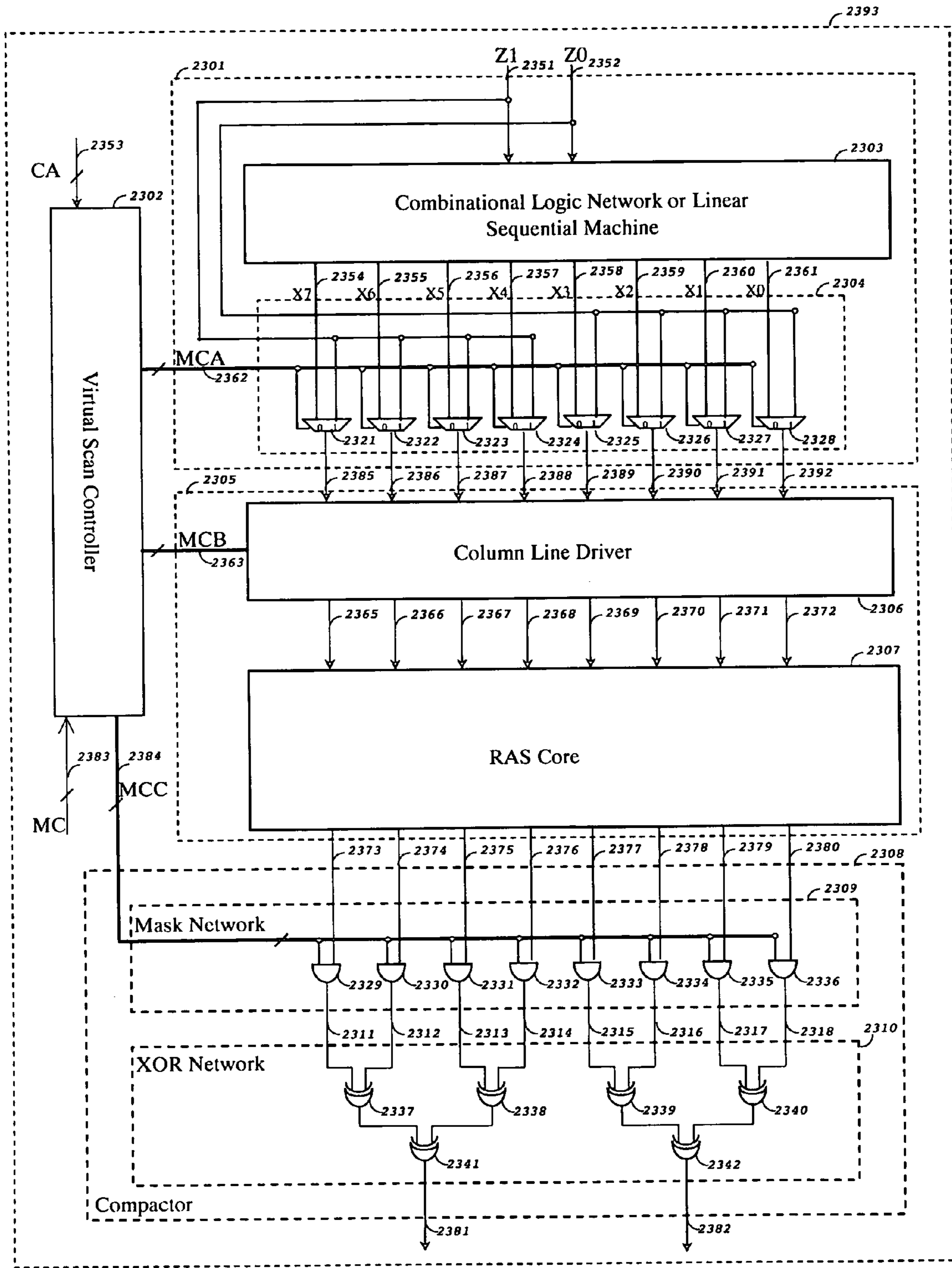

FIG. 23

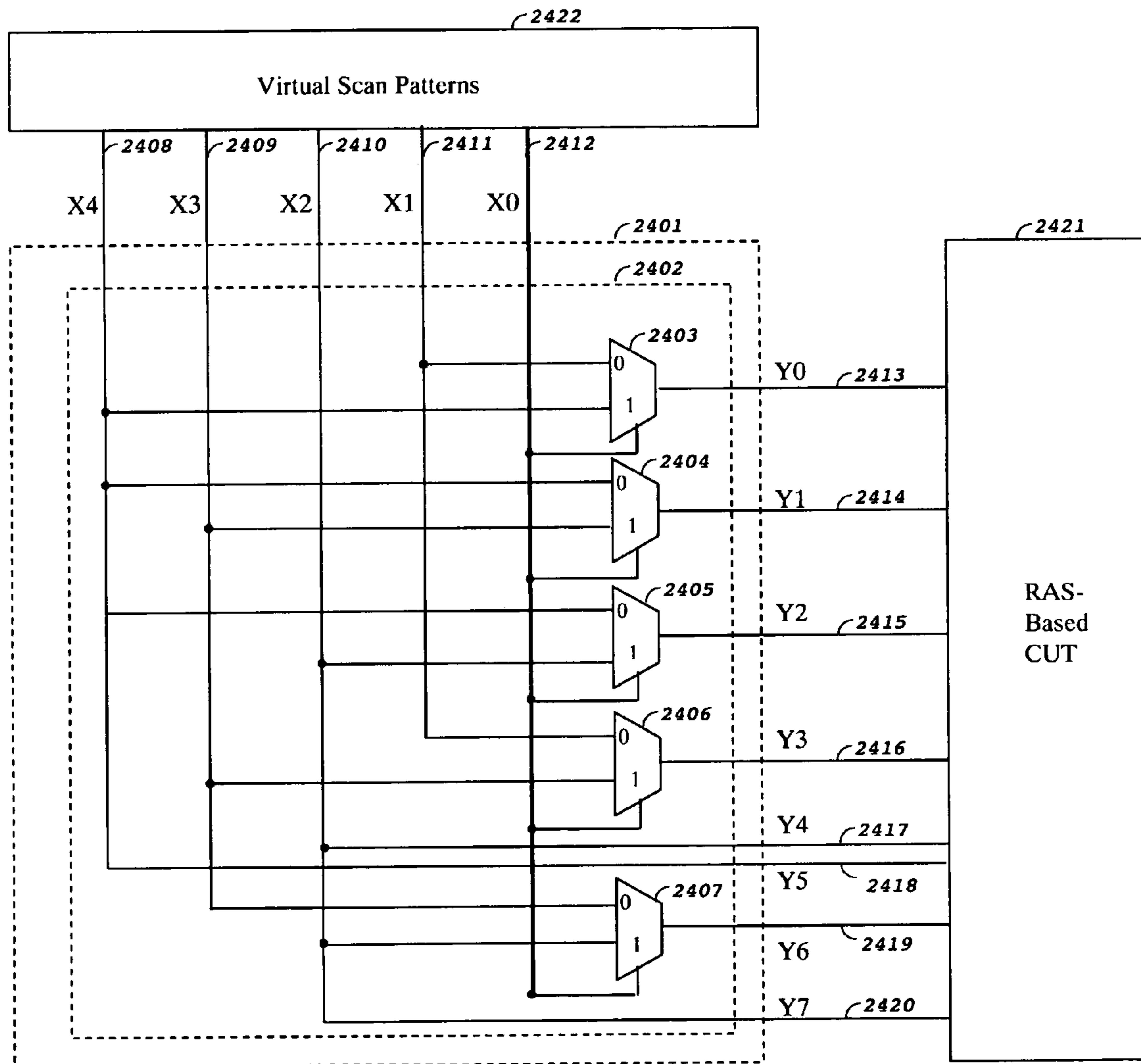

FIG. 24

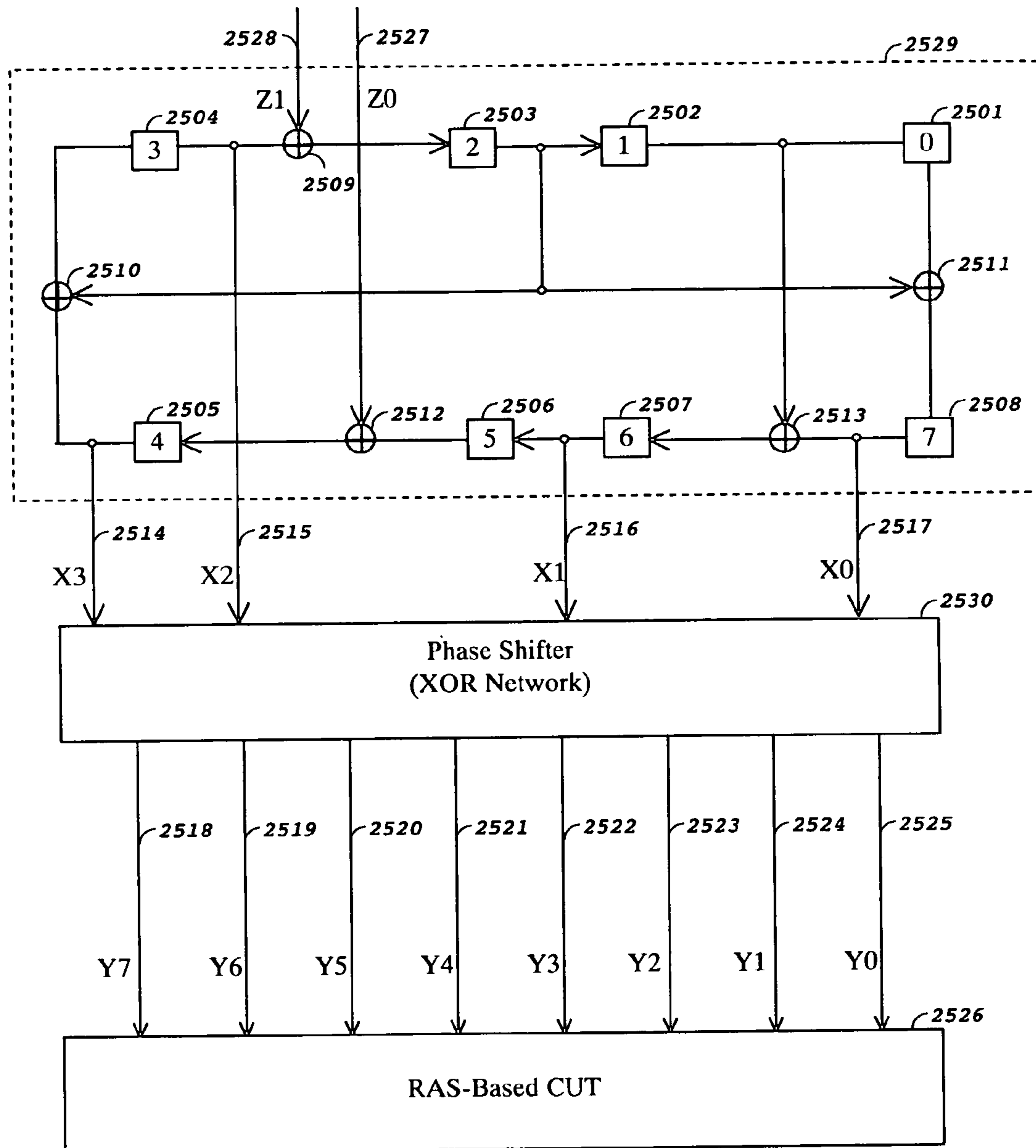

FIG. 25



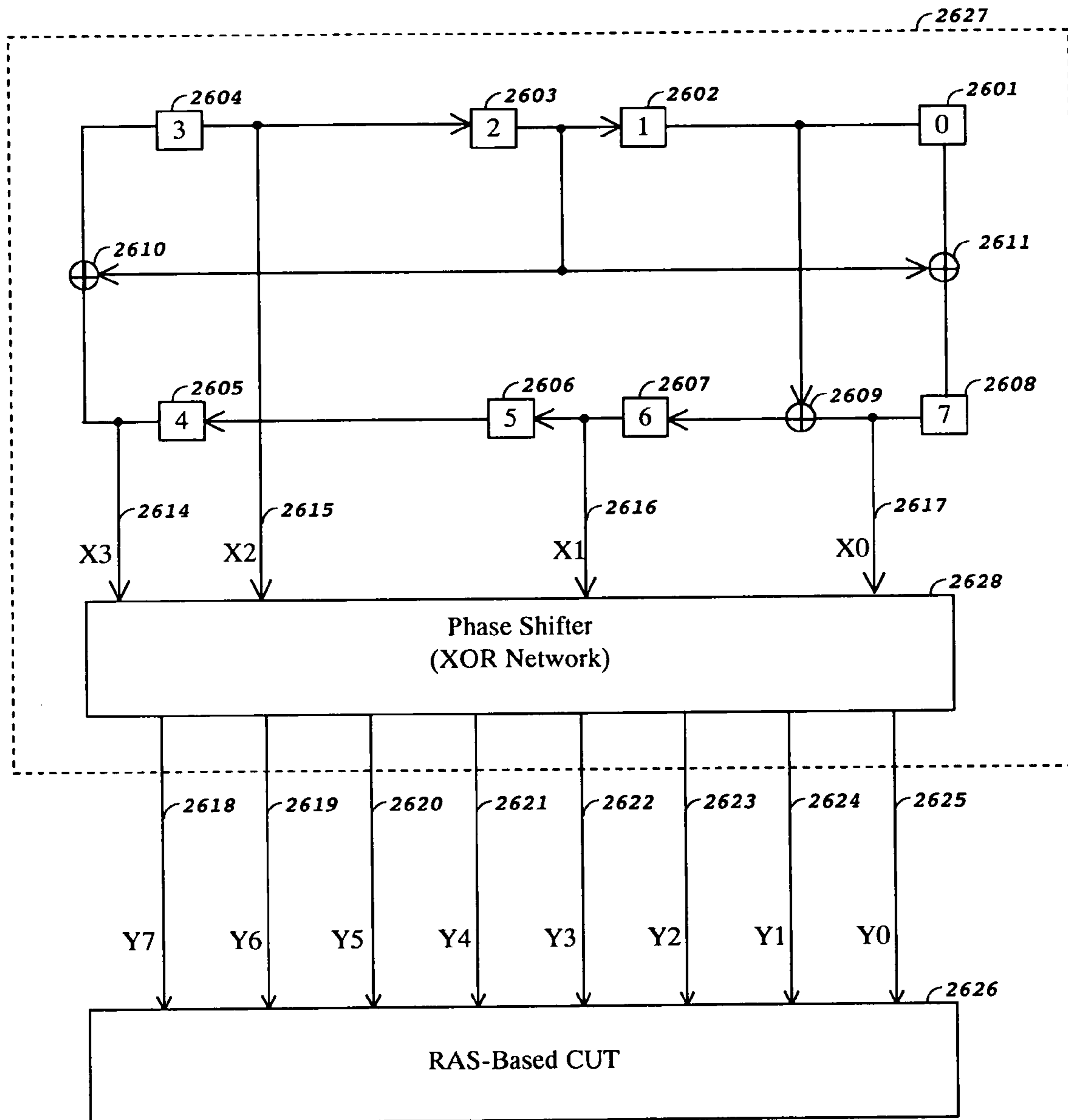

FIG. 26

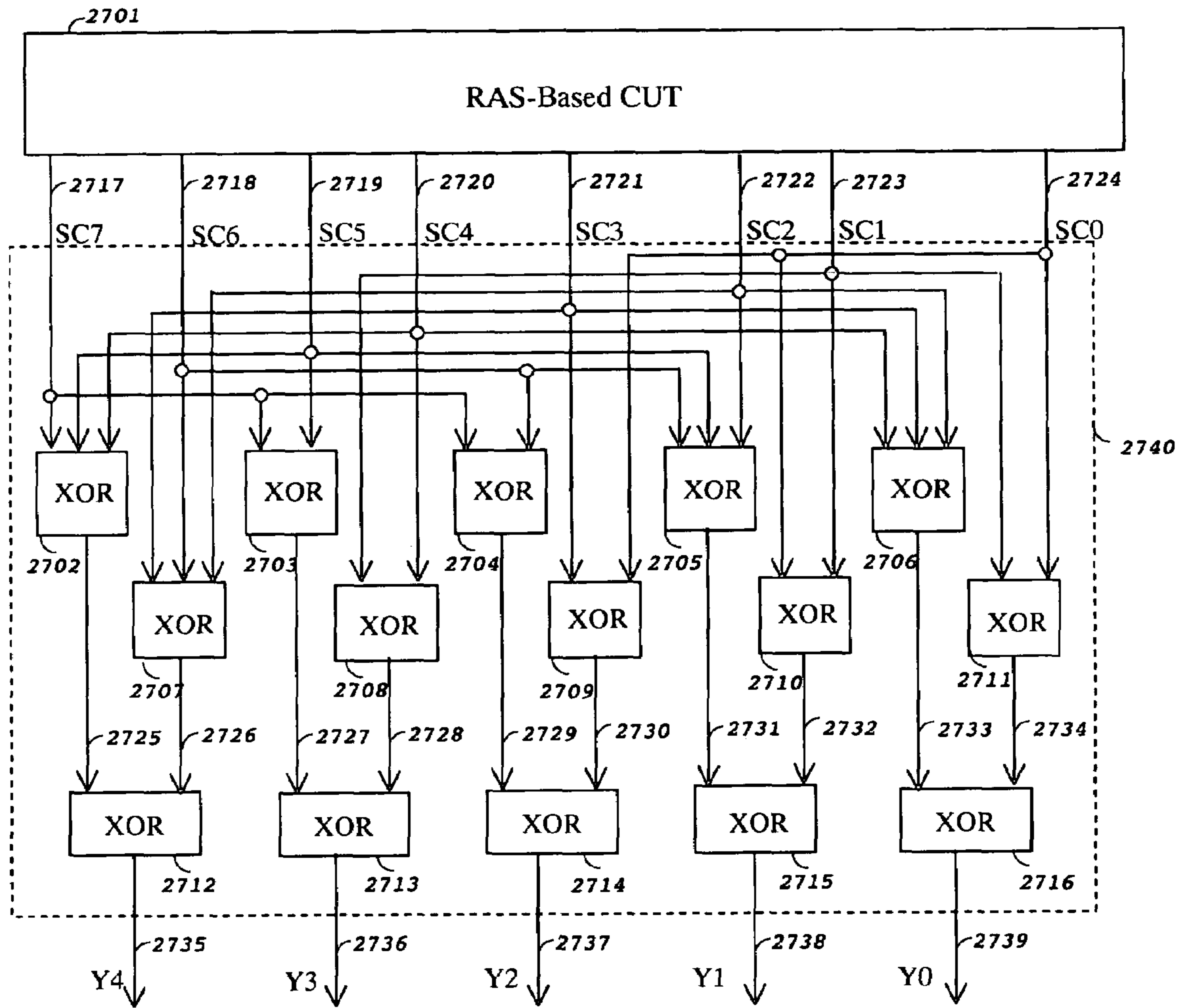

FIG. 27

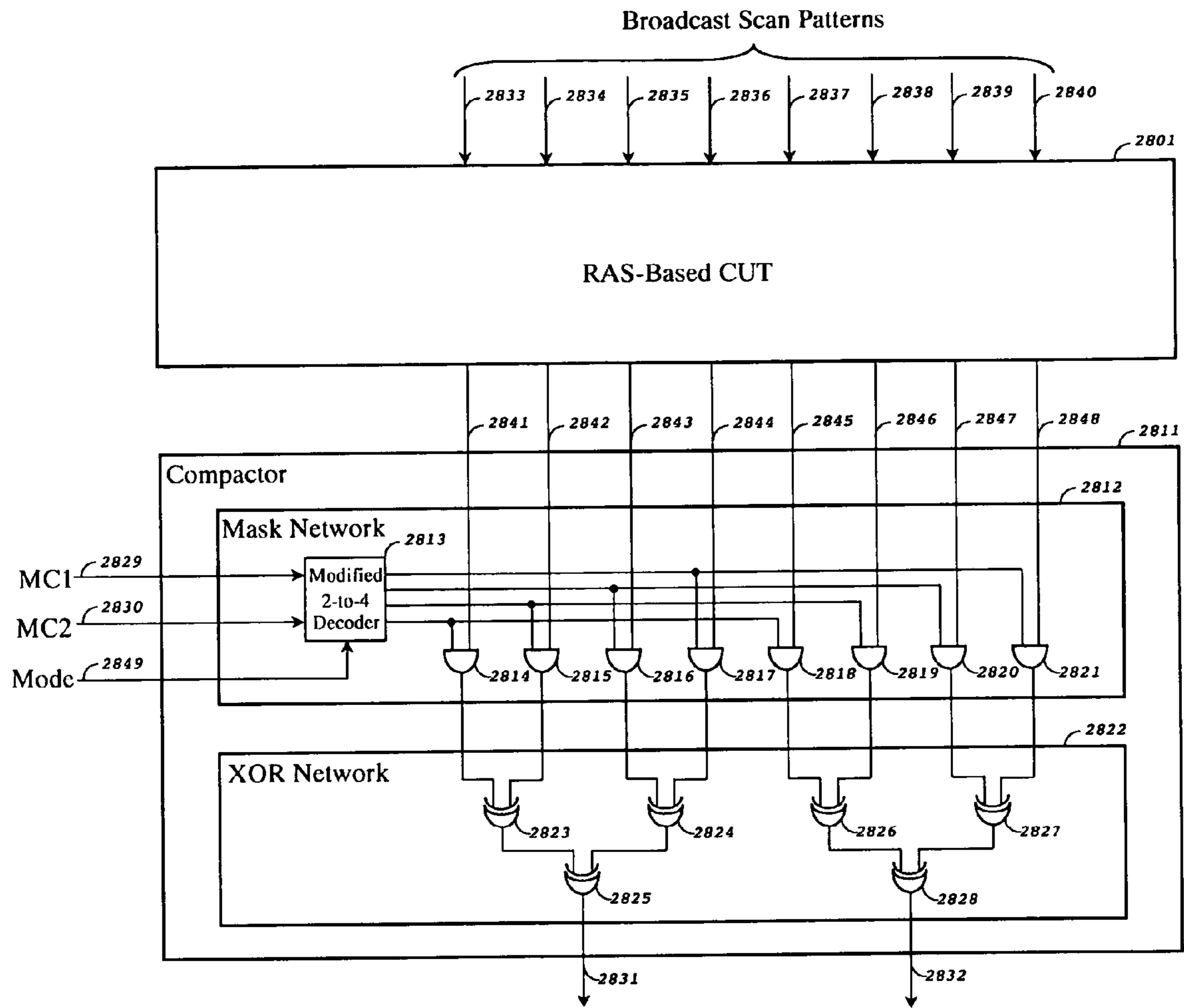

FIG. 28

**METHOD AND APPARATUS FOR  
BROADCASTING TEST PATTERNS IN A  
SCAN BASED INTEGRATED CIRCUIT**

REFERENCE TO RELATED APPLICATION

The present application is a continuation-in-part of application Ser. No. 10/339,667 filed Jan. 10, 2003 entitled METHOD AND APPARATUS FOR BROADCASTING SCAN PATTERNS IN A SCAN-BASED INTEGRATED CIRCUIT, the priority of which is claimed, and also claims the Priority of application Ser. No. 11/104,651 filed Apr. 13, 2005 entitled METHOD AND APPARATUS FOR BROADCASTING SCAN PATTERNS IN A SCAN-BASED INTEGRATED CIRCUIT.

TECHNICAL FIELD

The present invention generally relates to the field of logic design and test using design-for-test (DFT) techniques. Specifically, the present invention relates to the field of logic test and diagnosis for random access scan based integrated circuit.

BACKGROUND

As the complexity of integrated circuits increases, it becomes more and more important to achieve very high fault coverage while minimizing test cost. Although traditional scan-based methods have been quite successful in meeting these goals for sub-million gate designs during the past few decades, for recent scan-based designs larger than one-million gates, achieving this very high fault coverage at a reasonable price has become quite difficult. This is mainly due to the fact that it requires a significant amount of test-data storage volume to store scan patterns onto the automatic test equipment (ATE). In addition, this increase in test-data storage volume has resulted in a corresponding increase in the costs related to test-application time.

Conventional approaches for solving this problem focus on either adding more memory onto the ATE or truncating part of the scan data patterns. These approaches fail to adequately solve the problem, since the former approach adds additional test cost so as not to compromise the circuit's fault coverage, while the latter sacrifices the circuit's fault coverage to save test cost.

As an attempt to solve this problem, a number of prior art design-for-test (DFT) techniques have been proposed. These solutions focus on increasing the number of internal scan chains, in order to reduce test-data volume and hence test application time without increasing, and in some cases while decreasing or eliminating the number of scan-chains that are externally accessible. This removes package limitations on the number of internal scan chains that in some cases can even exceed the package pin count.

An example of such a DFT technique is Built-In Self-Test (BIST). See U.S. Pat. No. 4,503,537 issued to McAnney (1985). BIST implements on-chip generation and application of pseudorandom scan patterns to the circuit under test eliminating all external access to the scan-chains, and hence removing any limitation on the number of internal scan-chains that can be used. BIST, however, does not guarantee very high fault coverage and must often be used together with scan ATPG (automatic test pattern generation) to cover any remaining hard-to-detect faults.

Several different approaches for compressing test data before transmitting them to a circuit under test have been

proposed. See the papers co-authored by Koenemann et al. (1991), Hellebrand et al. (1995), Rajski et al. (1998), Jas et al. (2000), Bayraktaroglu et al. (2001), and U.S. Pat. No. 6,327,687 issued to Rajski et al. (2001). These methods are based on the observation that test cubes (i.e., arrangements of scan data patterns stored within the scan chains of a circuit under test) often contain a large number of unspecified (don't care) positions. It is possible to encode such test cubes with a smaller number of bits and later decompress them on-chip using an LFSR (linear-feedback shift register) based decompression scheme. This scheme requires solving a set of linear equations every time a test cube is generated using scan ATPG. Since solving these linear equations depends on the number of unspecified bits within a test cube, these LFSR-based decompression schemes often have trouble compressing an ATPG pattern without having to break it up into several individual patterns before compression, and hence have trouble guaranteeing very high fault coverage without having to add too many additional scan patterns.

A different DFT technique to reduce test data volume is based on broadcast scan. See the papers co-authored by Lee (1999) et al., Hamzaoglu et al. (1999), and Pandey et al. (2002). Broadcast scan schemes either directly connect multiple scan chains, called broadcast channels, to a single scan input or divide scan chains into different partitions and shift the same pattern into each partition through a single scan input. In these schemes, the connections between each and every scan input and its respective broadcast channels is done using either wires or buffers, without any logic gates, such as AND, OR, NAND, NOR, XOR, XNOR, MUX (multiplexer), or NOT (inverter) in between. Although it is possible to implement this scheme with practically no additional hardware overhead, it results in scan chains with very large correlation between different scan-chain data bits, resulting in input constraints that are too strong to achieve very high fault coverage.

Accordingly, there is a need to develop an improved method and apparatus for guaranteeing very high fault coverage while minimizing test data volume and test application time. The method we propose in this invention is based on broadcast scan, and thus, there is no need to solve any linear equations as a separate step after scan ATPG. A broadcast scan reordering approach is also proposed to further improve the circuit's fault coverage.

Test power issue is becoming a major challenge as scan-based designs reach multi-million gates. Power dissipation during scan testing is much higher than during normal circuit operation. It is important to reduce test power dissipation during scan testing since the circuit under test can be damaged by excessive heat. Various approaches have been proposed to alleviate the test power problem, often at the cost of higher test application time. In the paper co-authored by Wang, et al., an automatic test pattern generation ATPG based (ATPG-based) method was proposed. In the paper co-authored by Kajihara et al., a method to reduce test power using vector modification was described. A double-tree scan architecture for power reduction was proposed in the paper co-authored by Bhattacharya et al. The co-authors Wen et al. discussed a method to reduce capture power during scan testing. All these methods target scan-based designs where the storage elements are converted into scan cells, like multiplexed-D flip-flops or LSSD SRLs (shift register latches).

To solve the test power problem without adding much test application time, a random access scan (RAS) architecture authored by Ando can be used as opposed to the conventional serial scan architecture in a scan-based design. Each random access scan cell in the RAS architecture is randomly and

uniquely addressable in the random access manner. Two new RAS architectures aiming to reduce the silicon overhead were proposed in the papers co-authored by Baik et al. and Mudlapur et al. However, all these methods can only achieve a reduction of test data volume and test application time by around 2 times (2×), although test power can be reduced by 100×.

### SUMMARY

The method proposed in application Ser. No. 10/339,667 is based on broadcast scan, but adds a broadcaster circuit placed between the ATE (automatic test equipment) outputs and the scan chain inputs of the circuit under test. This broadcaster can be embedded on-chip or designed into the ATE. For the sake of simplicity, in this discussion we assume that the broadcaster is placed between the ATE and the integrated circuit under test without specifying where it is located physically. The following discussion applies regardless of where the broadcaster is embedded in an actual implementation.

The method according to application Ser. No. 10/339,667 is used to generate a broadcast scan patterns that are applied to the scan cells (memory elements) of an integrated circuit design under test. This process involves converting the virtual scan patterns stored in an ATE into broadcast scan patterns that are applied to the package scan input pins of the integrated circuit using a broadcaster. This broadcaster maps the virtual scan patterns into their corresponding broadcast scan patterns that are used to test for various faults, such as stuck-at faults, delay faults, and bridging faults in an integrated circuit. The integrated circuits tested contains multiple scan chains each consisting of any number of scan cells coupled together that store the broadcast scan pattern.

One important aspect of the invention in application Ser. No. 10/339,667 is the design of the broadcaster circuitry. The broadcaster can be as simple as a network of combinational logic circuitry (combinational logic network) or can possibly comprise a virtual scan controller in addition to a network of combinational logic. (Please refer to FIG. 4 and FIG. 6 in DETAILED DESCRIPTION OF THE DRAWINGS for more descriptions). Adding a virtual scan controller allows the mapping performed by the broadcaster to vary depending on the internal state of the controller. The broadcaster can also be implemented using a programmable logic array. In this scheme, each ATE output is connected to a subset of the scan chain (or scan partition) inputs via the combinational logic network. Any remaining inputs of the combinational logic network are directly connected to the virtual scan controller outputs if available. During scan test, the virtual scan controller is first loaded with a predetermined value using boundary-scan or other external means. This is used to initially setup the function of the broadcaster. Later in the test, It is possible and often desirable to load in a different predetermined value into the virtual scan controller in order to change the function of the broadcaster, and this can be repeated any number of times. This allows the outputs of the broadcaster to implement different or all combinations of logic functions. Since the function of the broadcaster is a programmable function of the value stored in the virtual scan controller, there is no limitation to the number of mappings that can be implemented. This relaxes the strong input constraints of traditional broadcast scan and increases the ability to generate broadcast scan patterns to test more and possibly all testable faults. This is true since the value stored in the virtual scan controller determines the input constraints imposed on the generation of broadcast scan patterns.

While a combinational logic network is the preferred implementation for the broadcaster due to its simplicity and low overhead, the broadcaster described in this invention can comprise a virtual scan controller and any combinational logic network. The virtual scan controller can be any general finite state machine, such as an LFSR (linear feedback shift register), as long as predetermined values can be loaded into all memory elements of the finite-state machine, such as D flip-flops or D latches, when desired. The combinational logic network can includes one or more logic gates, such as AND, OR, NAND, NOR, XOR, MUX, NOT gates, or any combination of the above. This combinational logic network increases the chance of generating broadcast scan patterns that test additional faults, such as pattern resistant faults when compared to traditional broadcast scan.

Another aspect of this invention is the creation and generation of broadcast scan patterns that meets the input constraints imposed by the broadcaster. When a combinational logic network is used to implement the broadcaster, the input constraints imposed by the broadcaster allow only a subset of the scan cells to receive a predetermined logic value either equal or complementary to the ATE output, at any time. Unlike the prior-art broadcast scan schemes which only allow all-zero and all-one patterns to be applied to the broadcast channels, the present invention allows different combinations of logic values to appear at these channels at different times. The only thing needed to generate these test patterns is to enhance the currently available ATPG tools to implement these additional input constraints. Hence, the process of generating broadcast scan patterns will be to generate patterns using an initial set of input constraints and to analyze the coverage achieved. If the fault coverage achieved is unsatisfactory, a different set of input constraints is applied and a new set of vectors are generated. This process is repeated until predetermined limiting criteria are met.

In order to reduce the number of input constraints needed to achieve very high fault coverage, the present invention may involve a broadcast scan chain reordering step before ATPG takes place. Our approach is to perform input-cone analysis from each cone output (scan cell input) tracing backwards to all cone inputs (scan cell outputs), and then to uses a maximal covering approach to reorder all cone inputs (scan cell outputs) so that only one constrained scan cell is located on a single broadcast channel during any shift clock cycle. These broadcast scan order constraints reduce, if not eliminate, the data dependency among broadcast channels associated with one ATE output. This gives the ATPG tool a better chance of generating broadcast scan patterns that achieve the target fault coverage without having to use a different set of input constraints. Please note that this applies only to integrated circuits that are still in the development phase, and hence broadcast scan reordering should be performed before the chip tapes out.

Although this process does add some CPU time to the ATPG process, it is much simpler and less computationally intensive as having to solve sets of linear equations after ATPG. The one-step "broadcast ATPG" process makes it easier to generate broadcast scan patterns as compared to LFSR-based decompression schemes. In addition, it is possible to use maximum dynamic compaction, an essential part of combinational ATPG, to fill in as many as unspecified (don't-care) positions in an effort to detect the most possible faults using a single scan pattern. This is in sharp contrast to LFSR-based decompression schemes where unspecified (don't-care) positions are desirable in order to be able to solve the linear equations needed to obtain a compressed test pattern. This is the fundamental conflict and flaw in LFSR-based

decompression schemes that require starting out with a set of ATPG vectors with little compaction in order to be able to generate a set of more compact vectors. This reduces the actual compaction achieved when compared to an initial set of compact ATPG vectors testing the same faults, and allows the virtual scan controller-based broadcast-scan method described in the present invention to cover more faults per scan test pattern than any LFSR-based decompression scheme.

#### The Present Invention

In the present invention, a broadcast scan test system using a random access scan (RAS) architecture, instead of the conventional serial scan architecture, is presented to reduce test power, test data volume, and test application time in an RAS-based integrated circuit. Using this new RAS architecture, it is possible to reduce test power, test data volume, and test application time by more than 10× at the same time. Random access scan cells (RAS cells) in the RAS-based integrated circuit are organized in rows and columns. Each RAS cell is randomly and uniquely addressable similar to a memory cell in a random access memory (RAM).

The broadcast scan test system of the present invention consists of a broadcaster, a compactor, and the RAS-based circuit under test (CUT). The RAS-based CUT includes a RAS core. When virtual scan patterns are applied from an ATE (automatic test equipment), broadcast test patterns generated by the broadcaster are loaded into each row of the RAS core in parallel, via the row control logic circuitry that can be a shift register, a ring counter, or a decoder. While a broadcaster test pattern is loaded into a row of RAS cells, the test response stored in the same row of RAS cells is transmitted to the compactor for compaction. Thus, pattern loading and response compaction can be performed simultaneously.

The RAS-based integrated circuit, according to this invention, can also be reconfigured into a serial RAS mode, where the number of external scan inputs or outputs is equal to the number of internal scan inputs to the RAS core, in order to reduce fault coverage loss caused by the broadcaster. This reconfigurable capability is also helpful for fault diagnosis and yield improvement.

The broadcaster of the RAS-based integrated circuit of this invention can be a pure buffer network, a MUX network, a combinational logic network, or a linear sequential machine. The broadcaster further comprises a scan connector that allows the RAS-based integrated circuit to be operated in various virtual scan modes where the number of external scan inputs or outputs is smaller than the number of internal scan inputs to the RAS core, or in serial scan mode where the number of external scan inputs or outputs is equal to the number of internal scan inputs to the RAS core.

The compactor of the RAS-based integrated circuit of this invention may be a conventional compactor comprising an XOR network, a multiple-input signature register (MISR), or an X-tolerant compactor, or an X-mask compactor.

This RAS architecture, combined with the test compression capability using the presented broadcaster and compactor, reduces test power, test data volume, and test application cost drastically simultaneously.

#### THE BRIEF DESCRIPTION OF DRAWINGS

The above and other objects, advantages and features of the invention will become more apparent when considered with the following specification and accompanying drawings wherein:

FIG. 1 shows a block diagram of a conventional system for testing scan-based integrated circuits using an automatic test equipment (ATE);

FIG. 2 shows a block diagram of a broadcast scan test system, in accordance with the present invention, for testing scan-based integrated circuits using an ATE;

FIG. 3 shows a prior art broadcaster design with only pure wires;

FIG. 4 shows a block diagram of a broadcaster, in accordance with the present invention, consisting of a combinational logic network and an optional scan connector;

FIG. 5A shows a first embodiment of a broadcaster shown in FIG. 4, in accordance with the present invention, consisting of a combinational logic network;

FIG. 5B shows the inputs constraint imposed by the embodiment of a broadcaster shown in FIG. 5A;

FIG. 5C shows a second embodiment of a broadcaster shown in FIG. 4, in accordance with the present invention, consisting of a combinational logic network and a scan connector;

FIG. 5D shows the inputs constraint imposed by the embodiment of a broadcaster shown in FIG. 5C;

FIG. 6 shows a block diagram of a broadcaster, in accordance with the present invention, consisting of a virtual scan controller, a combinational logic network, and an optional scan connector;

FIG. 7 shows a first embodiment of a broadcaster shown in FIG. 6, in accordance with the present invention;

FIG. 8 shows a second embodiment of a broadcaster shown in FIG. 6, in accordance with the present invention;

FIG. 9 shows a third embodiment of a broadcaster shown in FIG. 6, in accordance with the present invention;

FIG. 10 shows a fourth embodiment of a broadcaster shown in FIG. 6, in accordance with the present invention;

FIG. 11 shows a fifth embodiment of a broadcaster shown in FIG. 6, in accordance with the present invention;

FIG. 12 shows a sixth embodiment of a broadcaster shown in FIG. 6, in accordance with the present invention;

FIG. 13 shows a block diagram of a compactor, in accordance with the present invention, consisting of a mask network and a XOR network or a multiple-input signature register (MISR);

FIG. 14 shows a first embodiment of a compactor shown in FIG. 13, in accordance with the present invention;

FIG. 15 shows a second embodiment of a compactor shown in FIG. 13, in accordance with the present invention;

FIG. 16A shows an embodiment of the method before reordering scan cells or changing the scan chain length for generating broadcast scan patterns to test more faults, in accordance with the present invention;

FIG. 16B shows an embodiment of the method after reordering scan cells for generating broadcast scan patterns to test more faults, in accordance with the present invention;

FIG. 16C shows an embodiment of the method after changing the scan chain length for generating broadcast scan patterns to test more faults, in accordance with the present invention;

FIG. 17 shows a flow chart of the method for reordering scan cells for fault coverage improvement, in accordance with the present invention;

FIG. 18 shows a flow chart of the method for generating broadcast scan patterns used in testing scan-based integrated circuits, in accordance with the present invention;

FIG. 19 shows a flow chart of the method for synthesizing a broadcaster and a compactor to test a scan-based integrated circuit, in accordance with the present invention;

FIG. 20 shows an example system in which the broadcast scan test method, in accordance with the present invention, may be implemented;

FIG. 21 shows a block diagram of a broadcast scan test system based on a random access scan (RAS) architecture for testing an integrated circuit using an automatic test equipment (ATE);

FIG. 22 shows an embodiment of a random access scan (RAS) cell, RC, in the RAS core shown in FIG. 21, in accordance with the present invention;

FIG. 23 shows an embodiment of a scan connector of the broadcaster shown in FIG. 21, in accordance with the present invention;

FIG. 24 shows a first embodiment of the broadcaster shown in FIG. 21, in accordance with the present invention, using a multiplexer (MUX) network;

FIG. 25 shows a second embodiment of the broadcaster shown in FIG. 21, in accordance with the present invention, using an input-tapped linear sequential machine and an XOR network;

FIG. 26 shows a third embodiment of the broadcaster shown in FIG. 21, in accordance with the present invention, using a reseeding linear sequential machine and an XOR network;

FIG. 27 shows an embodiment of the compactor shown in FIG. 21, in accordance with the present invention, using an X-tolerant compactor; and

FIG. 28 shows an embodiment of the compactor shown in FIG. 21, in accordance with the present invention, using an X-mask compactor.

#### DETAILED DESCRIPTION OF THE INVENTION

The following description is presently contemplated as the best mode of carrying out the present invention. This description is not to be taken in a limiting sense but is made merely for the purpose of describing the principles of the invention. The scope of the invention should be determined by referring to the appended claims.

FIG. 1 shows a block diagram of a conventional system for testing scan-based integrated circuits using an ATE. The system 101 includes a tester or external automatic test equipment (ATE) 102 and a circuit-under-test (CUT) 107, which contains scan chains 109.

The ATE 102 applies a set of fully specified test patterns 103, one by one, to the CUT 107 via scan chains 109 in scan mode from external scan input pins 111 as well as from external primary input pins 113. The CUT is then run in normal mode using the applied test pattern as input, and the response to the test pattern is captured into the scan chains. The CUT is then put back into scan mode again and the test response is shifted out to the ATE via scan chains from external scan output pins 112 as well as from external primary output pins 114. The shifted-out test response 104 is then compared by the comparator 105 with the corresponding expected test response 106 to determine if any fault exists in the CUT, and indicates the result by the pass/fail signal 115.

In the conventional system 101, the number of scan chains 109 in the CUT 107 is identical to the number of the external scan input pins 111 or the number of the external scan output pins 112. Since the number of external pins is limited in an integrated circuit, the number of scan chains in the conventional system is also limited. As a result, a large integrated circuit with a large number of scan cells (SC) 108 usually contains very long scan chains for scan test. This will result in unacceptably large test data volume and costly long test application time.

FIG. 2 shows a block diagram of a broadcast scan test system, in accordance with the present invention, for testing scan-based integrated circuits using an ATE. The system 201 includes an ATE 202 and a circuit 207 that includes a broadcaster 208, a CUT 209, and a compactor 213. The CUT contains scan chains 211.

The broadcaster 208 may contain only a combinational logic network as shown in FIG. 4 or a virtual scan controller in addition to a combinational logic network as shown in FIG. 6. The broadcaster is used to map virtual scan patterns 203 to broadcast scan patterns, where the number of bits of a virtual scan pattern is usually smaller than that of a broadcast scan pattern. The mapping function of a broadcaster is fixed if it only contains a combinational logic network. However, the mapping function is variable if it also contains a virtual scan controller. In this case, the output values of the virtual scan controller can change the mapping function that the combinational logic network realizes, thus implementing different mapping relations from external scan input pins 215 to internal scan chain inputs 219. The compactor 213 is a combinational logic network, such as an XOR network, designed to map the internal scan chain outputs 220 to external scan output pins 216. Note that in practice, the number of external scan input or output pins is smaller than the number of internal scan chain inputs or outputs.

Note that the element 213 can be replaced with an optional space compactor and a multiple-input signature registers (MISR). In this case, all test responses will be compressed into a single signature, which can be compared with a reference signature either in the circuit 207 or in the ATE 202 after all broadcast scan patterns have been applied.

In addition, the compactor 213 usually contains a mask network used to block several output streams from coming into a XOR compaction network or a MISR. This is useful in fault diagnosis.

FIG. 3 shows a prior art broadcaster design with only pure wires. This example broadcaster design 301 has two broadcast scan inputs 314 and 315. The broadcast scan input 314 is connected directly to scan chains 303 to 307 while the broadcast scan input 315 is connected directly to scan chains 308 to 312. Although the overhead of this pure-wire broadcast design is very low, the test pattern dependency among the scan chains fed by the same broadcast scan input is very high. From the point of view of automatic test pattern generation (ATPG), this pure-wire broadcast design puts a strong constraint on the inputs to scan chains. As a result, this scheme usually suffers from severe fault coverage loss.

FIG. 4 shows a block diagram of a broadcaster, in accordance with the present invention, consisting of a combinational logic network and an optional scan connector. Virtual scan patterns are applied via broadcast scan inputs 407 of the broadcaster 401 to the combinational logic network 402. The combinational logic network implements a fixed mapping function, which converts a virtual scan pattern into a broadcast scan pattern. The broadcast scan pattern is then applied to all scan chains 409 in the CUT 404, through an optional scan connector 403.

The broadcaster 401 serves the purpose of providing test patterns to a large number of internal scan chains 406 through a small number of external broadcast scan input pins 407. As a result, all scan cells SC 405 in the CUT 404 can be configured into a large number of shorter scan chains. This will help in reducing test data column and test application time. By properly designing the combinational logic network 402, one can reduce the fault coverage loss caused by additional constraints imposed on the input pins of the scan chains.

FIG. 5A shows a first embodiment of a broadcaster shown in FIG. 4, in accordance with the present invention, consisting of a combinational logic network. In this example, a 3-bit virtual scan pattern is converted into an 8-bit broadcast scan pattern via the broadcaster 501.

The broadcaster 501 consists of a combinational logic network 502, which contains two inverters 503 and 507, one XOR gate 504, one OR gate 505, and one NOR gate 506. Virtual scan patterns are applied via broadcast scan inputs X2 518 to X0 520. The combinational logic network implements a fixed mapping function, which converts a virtual scan pattern into a broadcast scan pattern. The broadcast scan pattern is then applied to all scan chains 510 to 517 via Y7 521 to Y0 528 in the CUT 508.

FIG. 5B shows the inputs constraint imposed by the embodiment of a broadcaster shown in FIG. 5A.

The broadcaster 501 in FIG. 5A has three broadcast scan inputs X2 518 to X0 520. Thus, there are 8 input combinations for the broadcast scan inputs as listed under <X2, X1, X0> in the table 531. These are all possible input value combinations to the combinational logic network 502 in FIG. 5A. Therefore, as the outputs of the combinational logic network, there are 8 value combinations as listed under <Y7, Y6, Y5, Y4, Y3, Y2, Y1, Y0> in the table 531. These are all possible logic value combinations that may appear at the inputs of the scan chains 510 to 517 in FIG. 5A, and they are the input constraints in the process of ATPG.

FIG. 5C shows a second embodiment of a broadcaster shown in FIG. 4, in accordance with the present invention, consisting of a combinational logic network and a scan connector. In this example, a 3-bit virtual scan pattern is converted into an 8-bit broadcast scan pattern via the broadcaster 561.

The broadcaster 561 consists of a combinational logic network 562 and a scan connector 566. The combinational logic network contains one inverter 565, one XOR gate 563, and one OR gate 564. Virtual scan patterns are applied via broadcast scan inputs X2 581 to X0 583. The combinational logic network implements a fixed mapping function, which converts a virtual scan pattern into a broadcast scan pattern. The broadcast scan pattern is then applied to all scan chains 573 to 580 through the scan connector 566. The scan connector consists of one buffer 567, one inverter 570, one lock-up element LE 569, and one spare cell SC 568. Generally, two scan chains can be connected into one by using a buffer, an inverter, or a lock-up element in a scan connector. In addition, a spare cell can be added into an existing scan chain to change its length in order to reduce the dependency among different scan chains. This will help improve fault coverage.

FIG. 5D shows the inputs constraint imposed by the embodiment of a broadcaster shown in FIG. 5C.

The broadcaster 561 in FIG. 5C has three broadcast scan inputs X2 581 to X0 583. Thus, there are 8 input combinations for the broadcast scan inputs as listed under <X2, X1, X0> in the table 591. These are all possible input value combinations to the combinational logic network 562 in FIG. 5C. Therefore, as the outputs of the combinational logic network, there are 8 value combinations as listed under <Y4, Y3, Y2, Y1, Y0> in the table 591. These are the input constraints in the process of ATPG.

FIG. 6 shows a block diagram of a broadcaster, in accordance with the present invention, consisting of a virtual scan controller, a combinational logic network, and an optional scan connector.

The broadcaster 601 consists of a virtual scan controller 602, a combinational logic network 603, and an optional scan connector 604. Virtual scan patterns are applied via two types

of input pins: broadcast scan inputs 608 and virtual scan inputs 609. The broadcast scan inputs are connected directly to the combinational logic network, while the virtual scan inputs are connected directly to the virtual scan controller. In addition, the virtual scan controller may have optional virtual scan outputs 613.

Note that the virtual scan controller 602 can be either a combinational circuit such as a decoder, or a sequential circuit such as a shift register. The logic values applied through virtual scan inputs 609 may or may not change in each clock cycle although logic values applied through broadcast scan inputs 608 change in each clock cycle. The purpose of applying virtual scan input values is to change and store a proper set-up value combination in the virtual scan controller. This set-up value combination is applied to the combinational logic network 603 through 610 in order to change the mapping function that the combinational logic network implements. Since one mapping function corresponds to one set of input constraints for ATPG, providing the capability of changing mapping functions results in more flexible input constraints for ATPG. As a result, fault coverage loss due to the broadcast scheme can be substantially reduced.

Generally, the broadcaster 601 serves two purposes during test. One purpose is to provide test patterns to a large number of internal scan chains 607 through a small number of external broadcast scan input pins 608 and virtual scan input pins 609. As a result, all scan cells SC 606 in a circuit can be configured into a large number of shorter scan chains. This will help in reducing test data volume and test application time. Another purpose is to increase the quality of broadcast scan patterns applied from the combinational logic network 603 to all scan chains in order to obtain higher fault coverage. This is achieved by changing the values loaded into the virtual scan controller. Because of this flexibility, the combinational logic network can realize different mapping functions rather than a fixed one.

FIG. 7 shows a first embodiment of a broadcaster shown in FIG. 6, in accordance with the present invention. The broadcaster 701 consists of a virtual scan controller 702 and a combinational logic network 705. The virtual scan controller consists of two inverters 703 and 704. The combinational logic network is composed of 8 XOR gates 706 to 713. In this example, a 4-bit virtual scan pattern is converted into an 8-bit broadcast scan pattern via the broadcaster.

Obviously, the outputs 730 and 731 of the virtual scan controller 702 must have complementary values. In addition, the outputs 732 and 733 of the virtual scan controller must also have complementary values. Suppose that the values applied to the two broadcast scan inputs 728 and 729 are V1 and V2, respectively. In this case, the values appearing at scan chain inputs 734 to 743 should be P1, ~P1, P2, ~P2, V1, V2, P3, ~P3, P4, ~P4, respectively. Here P1 and ~P1 are complementary, P2 and ~P2 are complementary, P3 and ~P3 are complementary, P4 and ~P4 are complementary. In addition, P1 and P2 are either the same as V1 or the complement of V1, while P3 and P4 are either the same as V1 or are the complement of V2. This is the input constraint for ATPG.

FIG. 8 shows a second embodiment of a broadcaster shown in FIG. 6, in accordance with the present invention. The broadcaster 801 consists of a virtual scan controller 802 and a combinational logic network 804. The virtual scan controller consists of a 2-to-4 decoder 803. The combinational logic network is composed of 8 XOR gates 805 to 812. In this example, a 4-bit virtual scan pattern is converted into an 8-bit broadcast scan pattern via the broadcaster.

Obviously, there are four possible logic value combinations for the outputs 829 to 832 of the 2-to-4 decoder 803.



## 11

They are 1000, 0100, 0010, and 0001 for the outputs **829** to **832**, respectively. Suppose the output value combination of the 2-to-4 decoder is 1000. Also suppose that the logic values applied to the two broadcast scan inputs **827** and **828** are **V1** and **V2**, respectively. In this case, the values appearing at scan chain inputs **833** to **842** should be  $\sim V1$ , **V1**, **V1**, **V1**, **V1**, **V2**,  $\sim V2$ , **V2**, **V2**, **V2**, respectively. Here **V1** and  $\sim V1$  are complementary, while **V2** and  $\sim V2$  are complementary. This is the input constraint for ATPG. Obviously, by changing the values of virtual scan inputs **825** and **826**, one can get different set of input constraints for ATPG. This will help in improving fault coverage.

FIG. 9 shows a third embodiment of a broadcaster shown in FIG. 6, in accordance with the present invention.

The broadcaster **901** consists of a virtual scan controller **902** and a combinational logic network **911**. The virtual scan controller consists of an 8-stage shift register with memory elements **903** to **910**. There is one virtual scan input **932**, which is the input to the shift register. There is one optional virtual scan output **935**, which is the output of the shift register. Optionally, the virtual scan input and the virtual scan output can be connected to TDI and TDO in the boundary scan design, respectively. The combinational logic network is composed of 8 XOR gates **912** to **919**. There are two broadcast scan inputs, **933** and **934**. Test patterns applied via the input **933** are broadcasted to scan chains **922** to **926**; while test patterns applied via the input **934** are broadcasted to scan chains **927** to **931**.

The scan chains **926** and **927** are loaded directly from the broadcast scan input **933** and **934**, respectively, while the scan chains **922** to **925**, as well as the scan chains **928** to **931**, are loaded through XOR gates **912** to **915** and **916** to **919**, respectively. If the value of the memory element **903** is a logic 0, the scan chain **922** will get the identical values as those applied from the broadcast scan input **933**. If the value of the memory element **903** is a logic 1, the scan chain **922** will then get the complementary values to those applied from the broadcast scan input **933**. The same observation applies to the scan chains **923** to **925** as well as **928** to **931**. This means that, by applying a set of properly determined values to the shift register in the virtual scan controller **902**, it is possible to apply any of the 1024 combinations of logic values to the scan chains **922** to **931** in any shift cycle. As a result, any detectable fault in the CUT **920** can be detected by loading a set of properly determined logic values to the shift register and by applying a broadcast scan pattern through the inputs **933** and **934**.

From the point of view of ATPG, which tries to generate broadcast scan patterns to drive all scan chains in order to test the CUT **920**, the broadcaster configuration determined by the values of the memory elements in the shift register of the virtual scan controller **902** represents an input constraint. Suppose that the values for the memory elements **903** to **910** are 0, 1, 0, 1, 0, 1, 0, 1, respectively. In this case, the ATPG for the CUT should satisfy such an input constraint that, in any shift cycle, the scan chains **922**, **924**, and **926** have the identical value **V**, the scan chains **923** and **925** have the identical value  $\sim V$  that is the complement of **V**, the scan chains **927**, **928**, and **930** have the identical value **P**, the scan chains **929** and **931** have the identical value  $\sim P$  that is the complement of **P**.

FIG. 10 shows a fourth embodiment of a broadcaster shown in FIG. 6, in accordance with the present invention.

The broadcaster **1001** consists of a virtual scan controller **1002** and a combinational logic network **1006**. The virtual scan controller consists of a 3-stage shift register with memory elements **1003** to **1005**. There is one virtual scan

## 12

input **1023**, which is the input to the shift register. There is one optional virtual scan output **1026**, which is the output of the shift register. Optionally, the virtual scan input and the virtual scan output can be connected to TDI and TDO in the boundary scan design, respectively. The combinational logic network is composed of 4 XOR gates **1007** to **1010**. There are two broadcast scan inputs, **1024** and **1025**. Test patterns applied via the input **1024** are broadcasted to scan chains **1013** to **1017**; test patterns applied via the input **1025** are broadcasted to scan chains **1018** to **1022**.

The major difference between the broadcaster **901** in FIG. 9 and the broadcaster **1001** in FIG. 10 is that test patterns are broadcasted directly to some scan chains instead of going through XOR gates in the broadcaster **1001**. The scan chains **1013**, **1015**, and **1017** are driven directly from the broadcast scan input **1024**. This means that, in any shift cycle, scan chains **1013**, **1015**, and **1017** will have the identical values. In addition, the scan chains **1018**, **1020**, and **1022** are driven directly from the broadcast scan input **1025**. This means that, in any shift cycle, scan chains **1018**, **1020**, and **1022** will have the identical values. As a result, by applying a set of properly determined values to the shift register in the virtual scan controller **1002**, it is only possible to apply any of the 64 combinations of logic values to the scan chains **1013** to **1022** in any shift cycle. That is, the broadcaster **1001** needs less hardware overhead at the expense of stronger constraints at the inputs to the scan chains.

FIG. 11 shows a fifth embodiment of a broadcaster shown in FIG. 6, in accordance with the present invention.

The broadcaster **1101** consists of a virtual scan controller **1102** and a combinational logic network **1106**. The virtual scan controller consists of a 3-stage shift register with memory elements **1103** to **1105**. There is one virtual scan input **1127**, which is the input to the shift register. There is one optional virtual scan output **1130**, which is the output of the shift register. Optionally, the virtual scan input and the virtual scan output can be connected to TDI and TDO in the boundary scan design, respectively. The combinational logic network is composed of four XOR gate (**1108**, **1109**, **1112**, **1114**), two inverters (**1107**, **1113**), one AND gate (**1110**), and one OR gate (**1111**). There are two broadcast scan inputs, **1128** and **1129**. Test patterns applied via the input **1128** are broadcasted to scan chains **1117** to **1121**; test patterns applied via the input **1129** are broadcasted to scan chains **1122** to **1126**.

The broadcaster **1101** realizes more complex broadcast mapping relations from the broadcast scan inputs **1128** and **1129** to the inputs of the scan chains **1117** to **1126**. The general form of the mapping relations can be represented by  $\langle VB, VC, V, VC, V * P, V + P, PC1, PB, PC2, P \rangle$  corresponding to the inputs of the scan chains **1117** to **1126**, respectively. Here, **V** and **P** are two logic values applied from the broadcast scan inputs **1128** and **1129** in any shift cycle, respectively. **VB** and **PB** are the complements of **V** and **P**, respectively. **VC** equals **V** or **VB** if the output value of the memory element **1103** is a logic 0 or 1, respectively. **PC1** equals **P** or **PB** if the output value of the memory element **1104** is The present application is a continuation-in-part of application Ser. No. 10/339,667 filed Jan. 10, 2003 entitled METHOD AND APPARATUS FOR BROADCASTING SCAN PATTERNS IN A SCAN-BASED INTEGRATED CIRCUIT, the priority of which is claimed, and also claims the Priority of application Ser. No. 11/104,651 filed Apr. 13, 2005 entitled METHOD AND APPARATUS FOR BROADCASTING SCAN PATTERNS IN A SCAN-BASED INTEGRATED CIRCUIT. a logic 0 or 1, respectively; **PC2** equals **P** or **PB** if the output value of the memory element **1105** is a logic 0 or 1,

## 13

respectively. Obviously, the broadcast mapping relation can be changed by changing VC, PC1, and PC2 through loading different sets of logic values into the shift register in the virtual scan controller 1102. As a result, less inter-dependent test stimuli can be applied to the CUT 1115 so that higher fault coverage can be reached.

From the point of view of ATPG, which tries to generate broadcast scan patterns to drive all scan chains 1117 to 1126 in order to test the CUT 1115, the broadcaster configuration determined by the values of the memory elements in the shift register of the virtual scan controller 1102 represents an input constraint whose general form is <VB, VC, V, VC, V&P, V+P, PC1, PB, PC2, P>. This constrained ATPG can be performed if the original sequential CUT 1115 is transformed to a combinational circuit model reflecting the constraint after the values of the memory elements are determined.

FIG. 12 shows a sixth embodiment of a broadcaster shown in FIG. 6, in accordance with the present invention.

The broadcaster 1201 consists of a virtual scan controller 1202, a combinational logic network 1203, and a scan connector 1207. The combinational logic network contains two inverters 1204 and 1206 in addition to one OR gate 1205. Virtual scan patterns are applied via broadcast scan inputs 1226 and 1227 as well as a virtual scan input TDI 1224. One output X2 1229 from the virtual scan controller is applied to the combinational logic network, making it able to implement different mapping functions. The output values 1232 to 1236 from the combinational logic network is then applied to all scan chains 1215 to 1223 through the scan connector 1207. The scan connector consists of one buffer 1209, one inverter 1212, one lock-up element LE 1211, one spare cell SC 1210, and one multiplexer 1208. Generally, two scan chains can be connected into one by using a buffer, an inverter, or a lock-up element in a scan connector. In addition, a spare cell can be added into an existing scan chain to reduce the dependency among different scan chains. This will help improve fault coverage. Furthermore, a multiplexer can be used to split a scan chain into two parts. As shown in FIG. 12, if the selection signal 1228 of the multiplexer 1208 is a logic 1, the scan chains 1215 and 1216 will get different input value streams. However, if the selection signal 1228 of the multiplexer 1208 is a logic 0, the scan chains 1215 and 1216 can be seen as one scan chain, and only one input value stream goes through them. Obviously, a scan connector can be used to adjust the length of scan chains in the CUT in order to shorten test time or improve fault coverage.

FIG. 13 shows a block diagram of a compactor, in accordance with the present invention, consisting of a mask network and a XOR network or a MISR.

The test responses on the outputs 1308 of the CUT corresponding to broadcast scan patterns applied on the inputs 1307 of the CUT pass through a compactor 1304, which consists of a mask network 1305 and a XOR network or a MISR 1306. MC 1311 is the signal used to control the mask network. It can be applied from an ATE or generated by a virtual scan controller. The mask network is used to mask some inputs to a XOR network or a MISR. This is useful in fault diagnosis. A XOR network is used to conduct space compaction, i.e. reducing the number of test response lines going out of the circuit. On the other hand, a MISR can be used to compress test responses in both space and time domains. That is, there is no need to check test results cycle by cycle when a MISR is used. On the contrary, it is only necessary to compare the signature obtained at the end of the whole test session. However, it should be noted that no unknown values (X's) are allowed to come into a MISR. This means stricter design rules should be followed.

## 14

FIG. 14 shows a first embodiment of a compactor shown in FIG. 13, in accordance with the present invention.

The test responses on the outputs 1441 to 1448 pass through a mask network 1412 and then a XOR network 1422. The mask network consists of two groups of AND gates 1414 to 1417 and 1418 to 1421, each group being controlled by the four outputs generated by a modified 2-to-4 decoder 1413. In the diagnosis mode where the mode signal 1449 is a logic 1, this decoder maps logic values on MC1 1429 and MC2 1430 to one of the following combinations: 1000, 0100, 0010, and 0001. With any of these logic combination, it is clear that either group of AND gates will allow only one test response stream to pass to 1431 or 1432. Obviously, this will help in fault diagnosis. In the test mode where the mode signal 1449 is a logic 0, this decoder will generate an all-1 logic combination. This will allow all test response streams pass to 1431 or 1432. The XOR network 1422 consists of two groups of 4-to-1 XOR sub-networks, composed of XOR gates 1423 to 1425 and 1426 to 1428, respectively.

FIG. 15 shows a second embodiment of a compactor shown in FIG. 13, in accordance with the present invention.

The test responses on the outputs 1540 to 1547 pass through a mask network 1512 and then a MISR 1525. The mask network consists of two groups of AND gates 1517 to 1520 and 1521 to 1524, each group being controlled by the four outputs of a shift register composed of memory elements 1513 to 1516. In the diagnosis mode, this shift register can be loaded from TDI 1526 with one of the following combinations: 1000, 0100, 0010, and 0001. With any of these logic combination, it is clear that either group of AND gates will allow only one test response to pass stream to the MISR. Obviously, this will help in fault diagnosis. In the test mode, an all-1 logic combination will be loaded into the shift register. This will allow all test response streams pass to the MISR. The content of the MISR at the end of a test session can be shifted out from TDO 1529 for comparison with the expected signature.

FIG. 16A shows an embodiment of the method before reordering scan cells or changing the scan chain length for generating broadcast scan patterns to test more faults, in accordance with the present invention. A broadcaster 1601 has one broadcast scan input 1614, which broadcasts logic values to three scan chains, 1606, 1608, and 1611.

Since logic values are applied to the scan chain 1611 via an XOR gate 1604, by properly loading the shift register in the virtual scan controller 1602, it is possible, in any shift cycle, to apply any logic value which can be different from the one applied via scan chains 1606 and 1608. However, scan chains 1606 and 1608 will be loaded with the same logic values in any shift cycle. As a result, the scan cells A3 1607 and B3 1610 will have the same logic value in any broadcast test patterns. Since the outputs from the scan cells A3 1607 and B3 1610 are connected to the same combinational logic block 1612, it is possible that some faults in the combinational logic block cannot be detected due to this strong test pattern dependency. For example, in order to detect some faults in the combinational logic block, it may be necessary to have a logic 0 as the output of the scan cell A3 1607 and a logic 1 as the output of the scan cell B3 1610. Obviously, these faults will not be detected.

FIG. 16B shows an embodiment of the method after reordering scan cells for generating broadcast scan patterns to test more faults, in accordance with the present invention. A broadcaster 1601 has one broadcast scan input 1614, which broadcasts logic values to three scan chains, 1606, 1608, and 1611.

The only difference between FIG. 16A and FIG. 16B is that, in the scan chain 1608, the order of the scan cells B2 1609 and B3 1610 is changed. Now, although the outputs of the scan cells A3 1607 and B2 1609 have the same logic value in any shift cycle, the outputs of the scan cells A3 1607 and B3 1610 can have different logic values. As a result, this makes it possible to detect some faults that cannot be detected with the scan order shown in FIG. 16A.

FIG. 16C shows an embodiment of the method after changing the scan chain length for generating broadcast scan patterns to test more faults, in accordance with the present invention. A broadcaster 1601 has one broadcast scan input 1614, which broadcasts logic values to three scan chains, 1606, 1608, and 1611.

The only difference between FIG. 16A and FIG. 16C is that, one spare scan cell B0 1617 is added to the scan chain 1608 through a multiplexer 1618. It is clear that, if the selection signal 1619 is a logic 1, the spare scan cell will be added to the scan chain 1608. As a result, although the outputs of the scan cells A3 1607 and B2 1609 have the same logic value in any shift cycle, the outputs of the scan cells A3 1607 and B3 1610 can have different logic values. As a result, this makes it possible to detect some faults that cannot be detected with the scan order shown in FIG. 16A.

FIG. 17 shows a flow chart of the method for reordering scan cells for fault coverage improvement, in accordance with the present invention. This method 1700 accepts the user-supplied HDL codes 1701 together with the chosen foundry library 1702. The HDL codes represent a sequential circuit comprised of a broadcaster, a full-scan CUT, and a compactor as shown in FIG. 2. The HDL codes and the library are then compiled into an internal sequential circuit model 1704, which is then transformed into a combination circuit model 1706. Then, based on the original scan order information 1709 and the scan order constraints 1710, the input-cone analysis 1707 is conducted to identify scan cells whose order needs to be changed. Then, scan chain reordering 1708 is conducted. After that, the HDL test benches and tester programs 1711 are generated while all reports and errors are saved in the report files 1712.

FIG. 18 shows a flow chart of the method for generating broadcast scan patterns used in testing scan-based integrated circuits, in accordance with the present invention. This method 1800 accepts the user-supplied HDL codes 1801 together with the chosen foundry library 1802. The HDL codes represent a sequential circuit comprised of a broadcaster, a full-scan CUT, and a compactor as shown in FIG. 2. The HDL codes and the library are then compiled into an internal sequential circuit model 1804, which is then transformed into a combination circuit model 1806. Then, based on input constraints 1810, combinational fault simulation 1807 is performed, if so required, for a number of random patterns and all detected faults are removed from the fault list. After that, combinational ATPG 1808 is performed to generate virtual scan patterns and all detected faults are removed from the fault list. If predetermined limiting criteria, such as a pre-selected fault coverage goal, are met, the HDL test benches and ATE test programs 1811 are generated while all reports and errors are saved in the report files 1812. If the predetermined limiting criteria are not met, new input constraints 1810 will be used. For example, a new set of values can be loaded into the virtual scan controller to specify new input constraints. After that, optional random-pattern fault simulation 1807 and ATPG 1808 are performed. This iteration goes on until the predetermined limiting criteria are met.

FIG. 19 shows a flow chart of the method for synthesizing a broadcaster and a compactor to test a scan-based integrated

circuit, in accordance with the present invention. This method 1900 accepts the user-supplied HDL codes 1901 together with the chosen foundry library 1902. The HDL codes represent a sequential circuit comprised of a broadcaster, a full-scan CUT, and a compactor as shown in FIG. 2. The HDL codes and the library are then compiled into an internal sequential circuit model 1904. Then, based on the broadcaster constraints 1908 and the compactor constraints 1909, broadcaster synthesis 1905 and compactor synthesis 1906 are conducted, respectively. After that, based on the stitching constraints 1910, stitching 1907 is conducted to integrate the broadcaster and the compactor to the original circuit. At the end, the synthesized HDL codes 1911 are generated while all reports and errors are saved in the report files 1912.

FIG. 20 shows an example system in which the broadcast scan test method, in accordance with the present invention, may be implemented. The system 2000 includes a processor 2002, which operates together with a memory 2001 to run a set of the broadcast scan test design software. The processor 2002 may represent a central processing unit of a personal computer, workstation, mainframe computer or other suitable digital processing device. The memory 2001 can be an electronic memory or a magnetic or optical disk-based memory, or various combinations thereof. A designer interacts with the broadcast scan test design software run by processor 2002 to provide appropriate inputs via an input device 2003, which may be a keyboard, disk drive or other suitable source of design information. The processor 2002 provides outputs to the designer via an output device 2004, which may be a display, a printer, a disk drive or various combinations of these and other elements.

#### The Present Invention

FIG. 21 shows a block diagram of a broadcast scan test system based on a random access scan (RAS) architecture for testing an integrated circuit using an automatic test equipment (ATE). The system 2101 includes an ATE 2102 and an integrated circuit 2103 which in turn includes a broadcaster 2104, a RAS-based circuit under test (CUT) 2105, and a compactor 2106. The CUT 2105 contains a RAS core 2107. The RAS core 2107 comprises one or more random access scan cells RC 2113.

The broadcaster 2104 can be a pure buffer network as shown in FIG. 3, or a combinational logic network as shown in FIG. 5A, FIG. 6, FIG. 7, FIG. 8, FIG. 9, FIG. 10, FIG. 11, or FIG. 12, a multiplexer (MUX) network as shown in FIG. 24, or a linear sequential machine as shown in FIG. 25 or FIG. 26. In other words, the combinational logic network comprises one or more logic gates, including AND gates, OR gates, NAND gates, NOR gates, XOR gates, XNOR gates, multiplexers, buffers, inverters, or any combination of the above. The broadcaster 2104 may selectively further comprise a virtual scan controller for controlling the operation of the pure buffer network, the combinational logic network, or the linear sequential machine, using additional virtual scan inputs MC 2114. The broadcaster 2104 may further selectively comprise a scan connector to reconfigure the RAS core 2107 into different scan configurations in virtual scan modes or serial scan mode.

The broadcaster is used to map the virtual scan patterns 2110 to broadcast scan patterns. Aided by the column control logic 2109, the broadcaster can be configured to either a virtual scan mode where the number of bits of a virtual scan pattern is smaller than that of a broadcast scan pattern, or to the serial scan mode where the number of bits of a virtual scan pattern is equal to that of a broadcast scan pattern. For instance, assume the RAS-based CUT 2105 has 10 broadcast

scan inputs, and contains 160 columns (or scan chains) in the RAS core **2107**. This means the number of bits of the virtual scan pattern is 10. In virtual scan mode, the number of bits of the broadcast scan pattern will be 160 since the RAS core **2107** has 160 columns (or scan chains). In serial scan mode, the number of bits of the broadcast scan pattern will be 10 since the RAS core **2107** will be reconfigured to act as having 10 columns (or scan chains). The mode control signals MC **2114** are the signals used for mode control. These mode control signals MC **2114** can be applied from the ATE.

The compactor **2106** can be an XOR network as shown in FIG. **14**, a MISR as shown in FIG. **15**, an X-tolerant compactor as shown in FIG. **27**, or an X-mask compactor as shown in FIG. **28**. The compactor is used to map the internal scan outputs **2111** of the RAS core **2107** to external scan output pins **2112**, where the number of external scan output pins is equal to the number of broadcast scan inputs which is smaller than the number of internal scan inputs or outputs when the RAS-based CUT **2105** is tested in virtual scan mode. It is important to note that in the present invention, it is possible to operate the RAS-based CUT **2105** in more than one virtual scan modes as long as the number of external scan input or output pins is smaller than the number of internal scan inputs or outputs. Consider the example given above, where 10 original scan chains are split into 160 scan chains. One virtual scan mode may test the RAS-based CUT **2105** with 160 scan chains, while another virtual scan mode may test the RAS-based CUT **2105** with 80 scan chains reconfigured from the original 160 scan chains. The serial scan mode will test the RAS-based CUT **2105** with 10 scan chains reconfigured from the original 160 scan chains.

Random access scan cells in the RAS core are organized in rows and columns. When loading patterns, broadcast scan patterns are loaded to a selected row of scan cells at a time. At the same time, test responses stored in the selected row of scan cells are transmitted to the compactor for response compaction. The row control logic **2108** is used for row selection. The row control logic **2108** can be a shift register, a ring counter, or a decoder.

The column control logic **2109** is used for scan reconfiguration. In virtual scan mode, all columns are activated at the same time. In serial scan mode, columns are merged into groups so that the number of bits in the virtual scan pattern is equal to the number of bits in the broadcast scan pattern. In each group, only one column is selected at a time. For instance, by merging 160 columns (or scan chains) to 10 long columns (or scan chains) as in the above example, the broadcaster passes the 10-bit virtual scan pattern directly to the 10-bit broadcast scan pattern for testing the 10 long scan chains.

FIG. **22** shows an embodiment of a random access scan cell (RAS) cell, RC, in the RAS core shown in FIG. **21**. The RAS cell RC **2201** is obtained by modifying a static random access memory (SRAM) cell.

The RAS cell (RC) consists of four pass transistors **2213** to **2216**, four inverters **2217** to **2220**, two transistors  $M_a$  **2211** and  $M_b$  **2212**, one tri-state buffer **2221**, and one tri-state inverter **2222**. During normal operation, row enable signal RE **2233** is set to 0. With transistors  $M_a$  **2211** and  $M_b$  **2212** disconnected from the scan data output lines SD **2231** and  $\overline{SD}$  **2232**, the RAS cell acts as a regular D flip-flop with data input from D **2236** and data output connected to Q **2238**. In test mode, the clock  $\Phi$  **2244** holds 1 and the normal data is captured in the feedback loop of master latch **2202**. Note that when clock  $\Phi$  is kept at 1, the feedback loop of the master latch **2202**, together with  $M_a$  **2211** and  $M_b$  **2212**, form a traditional 6-transistor SRAM cell, and hence a read or write

operation can be performed. A read operation is performed with RE **2233** set to 1 and WE **2243** set to 0. The data stored in **2234** and **2235** are passed through  $M_a$  **2211** and  $M_b$  **2212** to scan data output lines SD **2231** and  $\overline{SD}$  **2232**. A write operation is performed with RE **2233** set to 0 and WE **2243** set to 1. The data present at the scan data input line SD **2242** are passed through tri-state buffer **2221**, tri-state inverter **2222**,  $M_a$  **2211**, and  $M_b$  **2212** to store its value in **2234** and **2235** of the master latch **2202**.

In the progressive random access scan architecture (PRAS) proposed in the paper co-authored by Baik et al., write operation is performed on one selected RAS cell at a time. In the present invention, write operation is performed over the entire row of RAS cells at a time. Thus write operation over RAS core in the present invention can be performed at a much faster speed than in PRAS.

FIG. **23** shows an embodiment of a scan connector of the broadcaster shown in FIG. **21**, in accordance with the present invention. In this example, a 2-bit virtual scan pattern Z1 **2351** and Z0 **2352** can be either expanded into an 8-bit broadcast scan pattern X7 **2354** to X0 **2361** and sent to the RAS-based CUT **2305** in virtual scan mode, or directly sent to the RAS-based CUT **2305** without being expanded in serial scan mode. The RAS-based CUT **2305** comprises a column line driver **2306** and a RAS core **2307**.

The broadcaster **2301** may further selectively comprise a virtual scan controller **2302** with virtual scan inputs from column address CA **2353** and mode control signals MC **2383**. The broadcaster **2301** may further selectively comprise a scan connector **2304** to reconfigure the RAS core **2307** into different scan configurations in virtual scan modes or serial scan mode. In this example, the scan connector **2304** comprises eight multiplexers **2321** to **2328**. A control signal MCA **2362** is connected to the control inputs of these eight multiplexers **2321** to **2328**. The 0 ports of the multiplexers **2321** to **2328** are connected to the outputs of the combinational logic network **2303**. The 1 ports of the four leftmost multiplexers **2321** to **2324** are connected to Z1 **2351**. The 1 ports of the four rightmost multiplexers **2324** to **2328** are connected to Z0 **2352**. The outputs of multiplexers **2321** to **2328** are connected to the inputs **2385** to **2392** of the RAS-based CUT **2305**. The combinational logic network **2303** comprises one or more logic gates, including AND gates, OR gates, NAND gates, NOR gates, XOR gates, XNOR gates, multiplexers, buffers, inverters, or any combination of the above.

Controlled by the virtual scan controller **2302**, the RAS-based CUT **2305** can be reconfigured and tested in various test modes, such as virtual scan modes and serial scan mode. The virtual scan controller **2302** can be either buffers, inverters, or a combinational logic such as a decoder, or a finite-state machine controller such as a shift register. The finite-state machine controller contains one or more memory elements, such as D flip-flops or D latches. It is loaded with a predetermined state during each shift cycle or before a test session starts to control the operation of the broadcaster. The scan connector **2304** in the broadcaster **2301**, the column line driver **2306** in the RAS-based CUT **2305**, and the mask network **2309** in the compactor **2308** perform such scan reconfigurability.

When the mode control signal MC **2383**, which is an input of the virtual scan controller **2302**, is set to 0, the RAS-based integrated circuit **2393** is configured into a virtual scan mode. In the virtual scan mode, the virtual scan controller **2302** generates a logic 0 at the control line MCA **2362** and a broadcast scan pattern on the combinational logic network outputs X7 **2354** to X0 **2361** is transmitted directly to the inputs of the RAS-based CUT **2385** to **2392**. The column line

driver 2306, controlled by the control line MCB 2363 from the virtual scan controller 2302, acts as a buffer in the virtual scan mode and transmits the signals at its inputs 2385 to 2392 directly to its outputs 2365 to 2372. On the compactor side, the virtual scan controller 2302 generates an all-one value at the control lines MCC 2384 allowing the test response appearing at the outputs 2373 to 2380 of the RAS core 2307 to pass through the mask network 2309 for compaction in the XOR network 2310. The XOR network 2310 receives inputs 2311 to 2318 from the mask network 2309 and compacts these signal values through the XOR gates 2337 to 2342 to generate the two output signals 2381 and 2382.

Conversely, when the mode control signal MC 2383 is set to 1, the RAS-based integrated circuit is configured into the serial scan mode. In the serial scan mode, the control line MCB 2363 is set to 1. Thus, the leftmost four inputs 2385 to 2388 of the column line driver 2306 are connected to the external input Z1 2351 without going through the combinational logic network 2303. Similarly the rightmost four inputs 2389 to 2392 of the column line driver 2306 are connected to the external input Z0 2352 without going through the combinational logic network 2303. The column line driver 2306 enables the columns of the RAS core 2307 fed by its four inputs 2365 to 2368 one at a time such that virtual scan patterns placed at the external input Z1 2351 is transmitted to one of those columns at a time. In a similar way, virtual scan patterns placed at the external input Z0 2352 is transmitted to one of those columns fed by inputs 2389 to 2392 of the column line driver 2306 at a time. In this way, the RAS core effectively receives virtual scan patterns directly from the two external inputs Z1 2351 and Z0 2352. On the compactor side, AND gates 2329 to 2336 in the mask network 2309 are enabled two at time, one from the group of AND gates 2329 to 2332, another from the group of AND gates 2333 to 2336. Thus in the serial scan mode, responses from two selected outputs 2373 to 2380 of the RAS-based CUT 2305 are compacted at a time.

FIG. 24 shows an embodiment of the broadcaster shown in FIG. 21, in accordance with the present invention, using a multiplexer (MUX) network. In this example, a 5-bit virtual scan pattern is converted into an 8-bit broadcast scan pattern via the broadcaster 2401.

The broadcaster consists of a MUX network 2402, which contains five multiplexers 2403 to 2407. Virtual scan patterns 2422 are applied via broadcast scan inputs X4 2408 to X0 2412. The MUX network 2402 implements a fixed mapping function, which converts a virtual scan pattern into a broadcast scan pattern. The broadcast scan pattern is then applied to the RAS-based CUT 2421 via Y0 2413 to Y7 2420.

The virtual scan input X0 2412 is connected to the control inputs of all multiplexers 2403 to 2407 in the MUX network 2402. By setting X0 2412 to two different logic values, 0 and 1, two different mapping functions between the virtual scan patterns and broadcast scan patterns are realized by the MUX network 2402.

FIG. 25 shows an embodiment of the broadcaster shown in FIG. 21, in accordance with the present invention, using an input-tapped linear sequential machine 2529 and an XOR network 2530. The XOR network 2530 is often referred to as a phase shifter 2530. In many cases, the phase shifter 2530 may not be needed.

In this example, 8-bit broadcast scan patterns Y7 2518 to Y0 2525 are generated by the broadcaster. The input-tapped linear sequential machine 2529 consists of eight D flip-flops 2501 to 2508 and five XOR gates 2509 to 2513. Two external scan inputs Z1 2528 and Z0 2527 are connected or tapped to the two XOR gates 2509 and 2512, respectively.

To generate broadcast scan patterns, all D flip-flops 2501 to 2508 in the input-tapped linear sequential machine 2529 are first initialized to an initial seed or a predetermined state during each shift cycle or between test sessions. Then, virtual scan patterns are loaded through external scan inputs Z1 2528 and Z0 2527 by cycling through the linear sequential machine 2529 for a predetermined number of clock cycles, while the generated patterns X3 2514 to X0 2517 are loaded into the RAS-based CUT 2526 via the optional phase shifter 2530.

FIG. 26 shows a second embodiment of the broadcaster shown in FIG. 21, in accordance with the present invention, using a reseeding linear sequential machine 2627 and an XOR network 2628. The XOR network 2628 is often referred to as a phase shifter 2628. In many cases, the phase shifter 2628 may not be needed.

In this example, 8-bit broadcast scan patterns Y7 2618 to Y0 2625 are generated by the broadcaster. The reseeding linear sequential machine 2627 consists of eight D flip-flops 2601 to 2608 and three XOR gates 2609 to 2611. No additional XOR gates are connected or tapped to external scan inputs as in the case of the input-tapped linear sequential machine 2529 shown in FIG. 25.

To generate broadcast scan patterns, all D flip-flops 2601 to 2608 in the reseeding linear sequential machine 2627 are first initialized to an initial seed or a predetermined state during each shift cycle or between test sessions. Then, virtual scan patterns are generated by cycling through the linear sequential machine 2627 for a predetermined number of clock cycles, while the generated patterns X3 2614 to X0 2617 are loaded into the RAS-based CUT 2626 via the optional phase shifter 2628.

FIG. 27 shows an embodiment of the compactor shown in FIG. 21, in accordance with the present invention, using an X-tolerant compactor 2740. The X-tolerant compactor 2740 is an XOR network with X-tolerance which means at least one external input of the XOR network is connected to the inputs of two or more XOR gates. An XOR network without X-tolerance means that each external input of the compactor is connected to only one input of an XOR gate.

The test response appeared at the output lines SC7 2717 to SC0 2724 of the RAS-based CUT 2701 passes through the X-tolerant compactor 2740 for compaction. The compaction result is sent out to ATE for comparison via outputs Y4 2735 to Y9 2739. The X-tolerant compactor 2740 comprises fifteen XOR gates 2702 to 2716.

To construct the X-tolerant compactor 2740, at least one output line SC7 2717 to SC0 2724 of the RAS-based CUT 2701 must be connected to two or more XOR gates 2702 to 2716. In this example, each output of the RAS-based CUT is connected to three different XOR gates to tolerate unknowns (X's). Take line SC7 2717 as an example, a fault effect on this line can only be blocked when there is an 'X' appearing at each of the following three groups of output lines: {SC6, SC5, SC4, SC3, SC2}, {SC5, SC4, SC1}, and {SC6, SC3, SC0}.

FIG. 28 shows an embodiment of the compactor shown in FIG. 21, in accordance with the present invention, using an X-mask compactor 2811.

The RAS-based CUT 2801 accepts a broadcast scan pattern 2833 to 2840 and generates a test response 2841 to 2848. The test response appearing at the output lines 2841 to 2848 of the RAS-based CUT 2801 passes through a mask network 2812 and an XOR network 2822. The mask network consists of two groups of AND gates. 2814 to 2817 and 2818 to 2821, each group being controlled by the four outputs generated by a modified 2-to-4 decoder 2813. In diagnosis mode or in serial scan mode where the signal mode 2849 is set to 1, this decoder 2813 decodes the logic values on the mode control signals

MC1 2829 and MC2 2830 to one of the following four logic combinations: 1000, 0100, 0010, and 0001. Each logic combination will allow only two output lines 2841 to 2848 of the test response to pass to 2831 and 2832. Obviously, this will help in fault diagnosis. In test mode where the signal mode 2849 is set to 0, this decoder 2813 will generate an all-1 logic value. This will allow the test response to pass to 2831 and 2832 through the XOR network 2822 for response compaction. The XOR network 2822 consists of two 4-to-1 XOR trees, composed of XOR gates 2823 to 2825 and XOR gates 2826 to 2828, respectively.

Having thus described presently preferred embodiments of the present invention, it can now be appreciated that the objectives of the invention have been fully achieved. And it will be understood by those skilled in the art that many changes in construction & circuitry, and widely differing embodiments & applications of the invention will suggest themselves without departing from the spirit and scope of the present invention. The disclosures and the description herein are intended to be illustrative and are not in any sense limitation of the invention, more preferably defined in scope by the following claims.

What is claimed is:

1. An apparatus that accepts a virtual scan pattern stored in an ATE (automatic test equipment) for generating broadcast scan pattern in a broadcaster having n broadcast scan inputs and m outputs to test a random access scan based (RAS-based) integrated circuit, where  $n < m$ , the RAS-based integrated circuit containing an m-input and m-output a RAS core organized in an array of RAS cells so that each row is randomly and uniquely addressable, the inputs to the RAS core connected to the outputs of the broadcaster, the outputs from the RAS core connected to the inputs of a compactor having m inputs and k outputs for compacting selected outputs of said RAS core for comparison in said ATE, where  $k < m$ , said apparatus comprising:

a) said broadcaster having said broadcast scan inputs that accepts virtual scan patterns via its said broadcast scan inputs for generating broadcast scan patterns as inputs to said RAS core; wherein said broadcaster comprises a combinational logic network comprising one or more logic gates, including AND gates, OR gates, NAND gates, NOR gates, XOR gates, XNOR gates, multiplexers, buffers, inverters, or any combination of the above.

2. The apparatus of claim 1, wherein said broadcaster further comprises a virtual scan controller connected to said combinational logic network for controlling the operation of said broadcaster during each shift cycle or between test sessions.

3. The apparatus of claim 1, further comprising using a scan connector to reconfigure said broadcaster, wherein said scan connector comprises one or more logic gates, including AND gates, OR gates, NAND gates, NOR gates, XOR gates, XNOR gates, multiplexers, buffers, inverters, or any combination of the above.

4. The apparatus of claim 2, wherein said virtual scan controller further comprises one or more buffers or inverters.

5. The apparatus of claim 2, wherein said virtual scan controller is a decoder.

6. The apparatus of claim 2, wherein said virtual scan controller is a finite-state machine controller containing one or more memory elements, such as D flip-flops or D latches, wherein said finite-state machine controller is loaded with a predetermined state during each shift cycle or before a test session starts.

7. The apparatus of claim 2, wherein said virtual scan controller is a shift register.

8. The apparatus of claim 2, wherein said virtual scan controller is a linear sequential machine containing one or more memory elements, such as D flip-flops or D latches, and one or more XOR gates that have no external inputs, wherein said linear sequential machine is loaded with a predetermined state during each shift cycle or before a test session starts.

9. The apparatus of claim 2, wherein said virtual scan controller is a linear sequential machine containing one or more memory elements, such as D flip-flops or D latches, and one or more XOR gates some of which have external inputs, wherein said finite-state machine controller is loaded with a predetermined state during each shift cycle or before a test session starts.

10. The apparatus of claim 1, further comprising transmitting said virtual scan patterns to said virtual scan inputs and said broadcast scan inputs of said broadcaster and transmitting said broadcast scan patterns generated by said broadcaster to selected scan data inputs of said scan cells in said RAS-based integrated circuit.

11. The apparatus of claim 1, further comprising storing said virtual scan patterns in an ATE (automatic test equipment), transmitting said virtual scan patterns to said broadcaster and transmitting said broadcast scan patterns generated by said broadcaster to said RAS-based integrated circuit for test manufacturing faults, including stuck-at faults, transition faults, path-delay faults, IDDQ (IDD quiescent current) faults, and bridging faults, within said RAS-based integrated circuit.

12. The apparatus of claim 1, further comprising placing said broadcaster selectively inside or external to said RAS-based integrated circuit.

13. The apparatus of claim 1, wherein said compactor is selectively modeled using simulation in said ATE or placed between said RAS-based integrated circuit and said ATE.

14. The apparatus of claim 1, wherein said compactor is selectively an XOR network with or without X-tolerance, or a multiple-input signature register (MISR), wherein said multiple-input signature register (MISR) further comprises a plurality of XOR gates and a plurality of memory elements, such as D flip-flops or D latches, wherein said XOR network with X-tolerance means that at least one external input of said XOR network is connected to the inputs of two or more XOR gates, and wherein said XOR network without X-tolerance means that each external input of said XOR network is connected to only one input of an XOR gate.

15. The apparatus of claim 1, wherein said compactor further comprises using a mask network to enable or disable testing or diagnosis of selected scan cells, wherein said mask network includes one or more AND gates.

16. The apparatus of claim 1, wherein said compactor is selectively placed within said RAS-based integrated circuit or inside said ATE.

17. A method that accepts a virtual scan pattern stored in an ATE (automatic test equipment) for generating broadcast scan pattern in a broadcaster having n broadcast scan inputs and m outputs to test a random access scan based (RAS-based) integrated circuit; where  $n < m$ . the RAS-based integrated circuit containing an m-input and m-output RAS core organized in an array of RAS cells so that each row is randomly and uniquely addressable, the inputs to the RAS core connected to the outputs of the broadcaster, the broadcaster comprising a combinational logic network that includes one or more logic gates, including AND gates, OR gates, NAND gates, NOR gates, XOR gates, XNOR gates, multiplexers, buffers, inverters, or any combination of the above, the outputs from the RAS core connected to the inputs of a compactor having m inputs and k outputs for compacting selected

outputs of said RAS core for comparison in said ATE, where  $k < m$ , said method comprising:

- a) placing said broadcaster between said ATE and said RAS-based integrated circuit;
- b) transmitting a new said virtual scan pattern stored in said ATE to said broadcaster for generating said broadcast scan pattern to test manufacturing faults in said RAS-based integrated circuit; and
- c) comparing the test response of said RAS-based integrated circuit with the expected test response.

18. The method of claim 17, wherein said broadcaster consists of pure buffer wires.

19. The method of claim 17, wherein said broadcaster having said broadcast scan inputs accepts said virtual scan patterns via its said broadcast scan inputs for generating said broadcast scan patterns as inputs to said RAS core.

20. The method of claim 17, wherein said broadcaster further comprising using a scan connector to reconfigure said broadcaster, wherein said scan connector comprises one or more logic gates, including AND gates, OR gates, NAND gates, NOR gates, XOR gates, XNOR gates, multiplexers, buffers, inverters, or any combination of the above.

21. The method of claim 17, wherein said broadcaster further comprises using a virtual scan controller to control said combinational logic network, wherein said virtual scan controller controls the operation of said broadcaster during each shift cycle or between test sessions.

22. The method of claim 21, wherein said virtual scan controller further comprises one or more buffers or inverters.

23. The method of claim 21, wherein said virtual scan controller is a decoder.

24. The method of claim 21, wherein said virtual scan controller is a finite-state machine controller containing one or more memory elements, such as D flip-flops or D latches, wherein said finite-state machine controller is loaded with a predetermined state during each shift cycle or before a test session starts.

25. The method of claim 21, wherein said virtual scan controller is a shift register.

26. The method of claim 21, wherein said virtual scan controller is a linear sequential machine containing one or more memory elements, such as D flip-flops or D latches, and one or more XOR gates that, have no external inputs, wherein said linear sequential machine is loaded with a predetermined state during each shift cycle or before a test session starts.

27. The method of claim 21, wherein said virtual scan controller is a linear sequential machine containing one or more memory elements, such as D flip-flops or D latches, and one or more XOR gates some of which have external inputs, wherein said finite-state machine controller is loaded with a predetermined state during each shift cycle or before a test session starts.

28. The method of claim 17, wherein said broadcaster is selectively placed within said scan-based integrated circuit or inside said ATE.

29. The method of claim 17, wherein said comparing the test response of said RAS-based integrated circuit with the expected test response further comprises using said compactor for compacting selected outputs of said integrated circuit for comparison, wherein said compactor is selectively modeled using simulation in said ATE or placed between said RAS-based integrated circuit and said ATE.

30. The method of claim 29, wherein said compactor is selectively an XOR network with or without X-tolerance, or a multiple-input signature register (MISR), wherein said multiple-input signature register (MISR) further comprises a plurality of XOR gates and a plurality of memory elements, such

as D flip-flops or D latches, wherein said XOR network with X-tolerance means that at least one external input of said XOR network is connected to the inputs of two or more XOR gates, and wherein said XOR network without X-tolerance means that each external input of said XOR network is connected to only one input of an XOR gate.

31. The method of claim 29, wherein said compactor further comprises using a mask network to enable or disable testing or diagnosis of selected scan cells, wherein said mask network includes one or more AND gates.

32. The method of claim 29, wherein said compactor is selectively placed within said RAS-based integrated circuit or inside said ATE.

33. The method of claim 17, wherein said broadcast scan patterns are chosen to test said manufacturing faults, including stuck-at faults, transition faults, path-delay faults, IDDQ (IDD quiescent current) faults, and bridging faults, in said RAS-based integrated circuit.

34. A method that accepts virtual scan patterns stored in an ATE (automatic test equipment) for generating broadcast scan patterns in a broadcaster having  $n$  broadcast scan inputs and  $m$  outputs to test a random access scan based (RAS-based) integrated circuit, where  $n < m$ , the RAS-based integrated circuit containing an  $m$ -input and  $m$ -output RAS core organized in an array of RAS cells so that each row is randomly and uniquely addressable, the inputs to the RAS core connected to the outputs of the broadcaster, the broadcaster comprising a combinational logic network that includes one or more logic gates, including AND gates, OR gates, NAND gates, NOR gates, XOR gates, XNOR gates, multiplexers, buffers, inverters, or any combination of the above, the outputs from the RAS core connected to the inputs of a compactor having  $m$  inputs and  $k$  outputs for compacting selected outputs of said RAS core for comparison in said ATE, where  $k < m$ , said system comprising:

- a) using simulation, modeling said broadcaster in said ATE;
- b) applying a new said virtual scan pattern stored in said ATE to generate said broadcast scan pattern using the simulated broadcaster model;
- c) transmitting said broadcast scan pattern generated by said broadcaster in said ATE to said scan cells in said RAS-based integrated circuit for testing manufacturing faults in said RAS-based integrated circuit; and
- d) comparing the test response of said RAS-based integrated circuit with the expected test response.

35. The method of claim 34, wherein said broadcaster consists of pure wires.

36. The method of claim 34, wherein said broadcaster having said broadcast scan inputs accepts said virtual scan patterns via its said broadcast scan inputs for generating said broadcast scan patterns as inputs to said RAS core.

37. The broadcaster of claim 34, further comprising using a scan connector to reconfigure said broadcaster, wherein said scan connector comprises one or more logic gates, including AND gates, OR gates, NAND gates, NOR gates, XOR gates, XNOR gates, multiplexers, buffers, inverters, or any combination of the above.

38. The method of claim 34, wherein said broadcaster further comprises using a virtual scan controller to control said combinational logic network, wherein said virtual scan controller controls the operation of said broadcaster during each shift cycle or between test sessions.

39. The method of claim 38, wherein said virtual scan controller further comprises one or more buffers or inverters.

40. The method of claim 38, wherein said virtual scan controller is a decoder.

## 25

41. The method of claim 38, wherein said virtual scan controller is a finite-state machine controller containing one or more memory elements, such as D flip-flops or D latches, wherein said finite-state machine controller is loaded with a predetermined state before a test session starts.

42. The method of claim 38, wherein said virtual scan controller is a shift register.

43. The method of claim 38, wherein said virtual scan controller is a linear sequential machine containing one or more memory elements, such as D flip-flops or D latches, and one or more XOR gates that have no external inputs, wherein said linear sequential machine is loaded with a predetermined state during each shift cycle or before a test session starts.

44. The method of claim 38, wherein said virtual scan controller is a linear sequential machine containing one or more memory elements, such as D flip-flops or D latches, and one or more XOR gates some of which have external inputs, wherein said finite-state machine controller is loaded with a predetermined state during each shift cycle or before a test session starts.

45. The method of claim 34, wherein said comparing the test response of said RAS-based integrated circuit with the expected test response further comprises using a compactor for compacting selected outputs of said integrated circuit for comparison, wherein said compactor is selectively modeled using simulation in said ATE or placed between said RAS-based integrated circuit and said ATE.

46. The method of claim 45, wherein said compactor is selectively an XOR network with or without X-tolerance, or a multiple-input signature register (MISR), wherein said multiple-input signature register (MISR) further comprises a plurality of XOR gates and a plurality of memory elements, such as D flip-flops or D latches, wherein said XOR network with X-tolerance means that at least one external input of said XOR network is connected to the inputs of two or more XOR gates, and wherein said XOR network without X-tolerance means that each external input of said XOR network is connected to only one input of an XOR gate.

47. The method of claim 45, wherein said compactor further comprises using a mask network to enable or disable testing or diagnosis of selected scan cells, wherein said mask network includes one or more AND gates.

48. The method of claim 45, wherein said compactor is selectively placed within said PAS-based integrated circuit or inside said ATE.

49. A broadcaster having  $n$  broadcast scan inputs and  $m$  outputs that accept virtual scan patterns via said broadcast scan inputs for generating broadcast scan patterns to test a scan-based integrated circuit, where  $n < m$ . the scan-based integrated circuit containing multiple scan chains, each scan chain comprising multiple scan cells, said broadcaster comprising:

- a) a multiplexer network directly connected to said broadcast scan inputs, said multiplexer network having outputs connected to selected scan inputs of all said scan chains.

50. The broadcaster of claim 49, further comprising a first scan connector for selectively selecting said outputs of said multiplexer network or selected scan outputs of all said scan chains for connection to selected scan inputs of all said scan chains; wherein said first scan connector comprises a second multiplexer network, and said second multiplexer network is controlled by one or more virtual scan inputs and is loaded with a predetermined state before a test session starts.

51. The broadcaster of claim 50, wherein said first scan connector further comprising a second scan connector inserted into a selected scan chain to reduce or eliminate the

## 26

inter-dependency of said selected scan chain on other selected scan chains using a multiplexer controlled by one or more said virtual scan inputs, wherein said second scan connector further comprises one or more spare scan cells.

52. The broadcaster of claim 49, further comprising a third scan connector inserted into the outputs of said multiplexer network and selected scan cells within said scan chains to selectively reorder the scan cells within each selected scan chain, split a selected scan chain to two or more short scan chains or merge a plurality of selected scan chains into one long scan chain, and wherein said third scan connector further comprises one or more multiplexers and wherein said multiplexers are controlled by one or more said virtual scan inputs.

53. The broadcaster of claim 49, further including a virtual scan controller comprising one or more memory elements, such as flip-flops or latches, for controlling the operation of said multiplexer network; wherein said virtual scan controller is controlled by one or more second virtual scan inputs and is loaded with a predetermined state before a test session starts.

54. The broadcaster of claim 53, wherein said virtual scan controller is a finite-state machine.

55. The broadcaster of claim 53, wherein said virtual scan controller is a shift register.

56. The broadcaster of claim 49, wherein said multiplexer network further comprises one or more combinational logic gates, selected from AND gates, OR gates, NAND gates, NOR gates, XOR gates, XNOR gates, buffers, inverters, or a combination of the above.

57. The broadcaster of claim 49, further comprising means for transmitting said virtual scan patterns to said broadcast scan inputs and selected virtual scan inputs of said broadcaster and transmitting said broadcast scan patterns generated by said broadcaster to selected scan inputs of said scan chains in said scan-based integrated circuit.

58. The broadcaster of claim 49, including an ATE (automatic test equipment) wherein said virtual scan patterns are stored in said ATE, transmitting said virtual scan patterns from said ATE to said broadcaster and transmitting said broadcast scan patterns generated by said broadcaster to said scan-based integrated circuit for test manufacturing faults, including stuck-at faults, transition faults, path-delay faults, IDDQ (IDD quiescent current) faults, and bridging faults, within said scan-based integrated circuit.

59. The broadcaster of claim 49, wherein said broadcaster is selectively located inside or external to said scan-based integrated circuit.

60. A method that accepts a virtual scan pattern stored in an ATE (automatic test equipment) for generating a broadcast scan pattern in a broadcaster having  $n$  broadcast scan inputs and  $m$  outputs to test a scan-based integrated circuit, where  $n < m$ . the broadcaster accepting the virtual scan patterns via broadcast scan inputs for generating the broadcast scan patterns, the scan-based integrated circuit containing multiple scan chains, each scan chain comprising multiple scan cells, the scan chains coupled to the broadcaster, the broadcaster comprising a multiplexer network directly connected to said broadcast scan inputs, said multiplexer network having selected outputs and selected scan outputs of all said scan chains connected to selected scan inputs of all said scan chains, said method comprising:

- a) placing said broadcaster between said ATE and said scan-based integrated circuit;
- b) transmitting said virtual scan pattern stored in said ATE to said broadcaster for generating said broadcast scan pattern to test manufacturing faults in said scan-based integrated circuit; and



c) comparing a test response of said scan-based integrated circuit with an expected test response.

**61.** The method of claim **60**, further comprising a first scan connector for connecting the outputs of said multiplexer network and selected scan outputs of all said scan chains to selected scan inputs of all said scan chains; wherein said first scan connector further comprises a second multiplexer network controlled by one or more virtual scan inputs.

**62.** The method of claim **60**, further comprising a second scan connector inserted into the outputs of said multiplexer network and selected scan cells within said scan chains to selectively reorder the scan cells within each selected scan chain, split a selected scan chain to two or more short scan chain; or merge a plurality of selected scan chains into one long scan chain; and wherein said second scan connector includes one or more buffers, inverters, lockup elements each comprising a memory element such as flip-flop or latch, spare scan cells, multiplexers, or any combination of the above.

**63.** The method of claim **60**, wherein said broadcaster further includes using a virtual scan controller comprising one or more memory elements, such as flip-flops or latches to control said multiplexer network; wherein said virtual scan controller is connected to one or more virtual scan inputs and is loaded with a predetermined state before a test session starts.

**64.** The method of claim **63**, wherein said selected virtual scan controller is a finite-state machine.

**65.** The method of claim **63**, wherein said selected virtual scan controller is a shift register.

**66.** The method of claim **60**, wherein said multiplexer network further comprises one or more combinational logic gates, selected from AND gates, OR gates, NAND gates, NOR gates, XOR gates, XNOR gates, buffers, inverters, or a combination of the above.

**67.** The method of claim **60**, further comprising means for transmitting said virtual scan patterns to said broadcast scan inputs and said virtual scan inputs of said broadcaster and transmitting said broadcast scan patterns generated by said broadcaster to selected scan inputs of said scan chains in said scan-based integrated circuit.

**68.** The method of claim **60**, wherein said broadcaster is selectively placed within said scan-based integrated circuit or inside said ATE.

**69.** The method of claim **60**, wherein said comparing a test response of said scan-based integrated circuit with an expected test response further comprises using a compactor for compacting selected outputs of said scan-based integrated circuit for comparison, wherein said compactor is selectively modeled using simulation in said ATE or placed between said scan-based integrated circuit and said ATE.

**70.** The method of claim **69**, wherein said compactor is selectively an XOR network or a multiple-input signature register (MISR), wherein said multiple-input signature register (MISR) further comprises a plurality of XOR gates and a plurality of memory elements, such as flip-flops or latches.

**71.** The method of claim **69**, wherein said compactor further includes using a mask network to enable or disable testing or diagnosis of selected scan cells in selected scan chains, wherein said mask network includes one or more selected second AND gates, selected second NAND gates, selected second OR gates, selected second NOR gates, and selected second multiplexers.

**72.** The method of claim **69**, wherein said compactor is selectively placed within said scan-based integrated circuit or inside said ATE.

**73.** The method of claim **60**, wherein said broadcast scan patterns are chosen to test said manufacturing faults, including stuck-at faults, transition faults, path-delay faults, IDDQ (IDD quiescent current) faults, and bridging faults, in said scan-based integrated circuit.

**74.** A method that accepts a virtual scan pattern stored in an ATE (automatic test equipment) for generating a broadcast scan pattern in a broadcaster having  $n$  broadcast scan inputs and  $m$  outputs to test a scan-based integrated circuit, where  $n < m$ . the broadcaster accepting the virtual scan patterns via broadcast scan inputs for generating the broadcast scan patterns, the scan-based integrated circuit containing multiple scan chains, each scan chain comprising multiple scan cells, the scan chains coupled to the broadcaster, the broadcaster comprising a multiplexer network directly connected to said broadcast scan inputs, said multiplexer network having selected outputs and selected scan outputs of all said scan chains connected to selected scan inputs of all said scan chains, said method comprising:

- a) using simulation, modeling said broadcaster in said ATE;
- b) applying said virtual scan pattern stored in said ATE to generate said broadcast scan pattern using the simulated broadcaster model;
- c) transmitting said broadcast scan pattern generated by said broadcaster in said ATE to said scan chains in said scan-based integrated circuit for testing manufacturing faults in said scan-based integrated circuit; and
- d) comparing a test response of said scan-based integrated circuit with an expected test response.

**75.** The method of claim **74**, further comprising a first scan connector for selectively selecting the outputs of said multiplexer network and selected scan outputs of all said scan chains for connection to selected scan inputs of all said scan chains; wherein said first scan connector further comprises a second multiplexer network controlled by one or more virtual scan inputs.

**76.** The method of claim **74**, further comprising a second scan connector inserted into the outputs of said multiplexer network and selected scan cells within said scan chains to selectively reorder the scan cells within each selected scan chain, split a selected scan chain to two or more short scan chains, or merge a plurality of selected scan chains into one long scan chain; and wherein said second scan connector includes one or more buffers, inverters, lockup elements each comprising a memory element such as flip-flop or latch, spare scan cells, multiplexers, or any combination of the above.

**77.** The method of claim **74**, wherein said broadcaster further includes using a virtual scan controller comprising one or more memory elements, such as flip-flops or latches to control said multiplexer network; wherein said virtual scan controller is connected to one or more virtual scan inputs and is loaded with a predetermined state before a test session starts.

**78.** The method of claim **77**, wherein said selected virtual scan controller is a finite-state machine.

**79.** The method of claim **77**, wherein said selected virtual scan controller is a shift register.

**80.** The method of claim **74**, wherein said multiplexer network further comprises one or more combinational logic gates, selected from AND gates, OR gates, NAND gates, NOR gates, XOR gates, XNOR gates, buffers, inverters, or a combination of the above.

**81.** The method of claim **74**, further comprising means for transmitting said virtual scan patterns to said broadcast scan inputs and said virtual scan inputs of said broadcaster, and means for transmitting said broadcast scan patterns generated

by said broadcaster to selected scan inputs of said scan chains in said scan-based integrated circuit.

**82.** The method of claim **74**, wherein said comparing a test response of said scan-based integrated circuit with an expected test response further comprises using a compactor for compacting selected outputs of said scan-based integrated circuit for comparison, wherein said compactor is selectively modeled using simulation in said ATE or placed between said scan-based integrated circuit and said ATE.

**83.** The method of claim **82**, wherein said compactor is selectively an XOR network or a multiple-input signature register (MISR), wherein said multiple-input signature register (MISR) further comprises a plurality of XOR gates and a plurality of memory elements, such as flip-flops or latches.

**84.** The method of claim **82**, wherein said compactor further includes using a mask network to enable or disable test-

ing or diagnosis of selected scan cells in selected scan chains, wherein said mask network includes one or more selected second AND gates, selected second NAND gates, selected second OR gates, selected second NOR gates, and selected second multiplexers.

**85.** The method of claim **82**, wherein said compactor is selectively placed within said scan-based integrated circuit or inside said ATE.

**86.** The method of claim **74**, wherein said broadcast scan patterns are chosen to test said manufacturing faults, including stuck-at faults, transition faults, path-delay faults, IDDQ (IDD quiescent current) faults, and bridging faults, in said scan-based integrated circuit.

\* \* \* \* \*