



US007389673B2

(12) **United States Patent**  
**Kimura et al.**

(10) **Patent No.:** **US 7,389,673 B2**  
(45) **Date of Patent:** **Jun. 24, 2008**

(54) **SENSOR FOR DETECTING ANALYTE IN LIQUID AND DEVICE FOR DETECTING ANALYTE IN LIQUID USING THE SAME**

(58) **Field of Classification Search** ..... 73/24.01, 73/24.06, 61.75, 64.53; 310/313 R, 313 B, 310/313 D

See application file for complete search history.

(75) Inventors: **Tetsuya Kimura**, Omihachiman (JP); **Koji Fujimoto**, Otsu (JP); **Kenjiro Okaguchi**, Moriyama (JP); **Shinya Yamamoto**, Otsu (JP); **Ryoichi Morimoto**, Yasu (JP); **Toru Yabe**, Konan (JP)

(56) **References Cited**

U.S. PATENT DOCUMENTS

4,312,228 A \* 1/1982 Wohltjen ..... 73/597  
4,735,906 A \* 4/1988 Bastiaans ..... 436/527  
4,895,017 A \* 1/1990 Pyke et al. .... 73/24.06

(Continued)

FOREIGN PATENT DOCUMENTS

JP 63-250560 A 10/1988

(Continued)

OTHER PUBLICATIONS

Official Communication for PCT Application No. PCT/JP2005/015185; mailed on Nov. 22, 2005.

*Primary Examiner*—Hezron E. Williams

*Assistant Examiner*—Rose M Miller

(74) *Attorney, Agent, or Firm*—Keating & Bennett, LLP

(73) Assignee: **Murata Manufacturing Co., Ltd.**, Kyoto (JP)

(\*) Notice: Subject to any disclaimer, the term of this patent is extended or adjusted under 35 U.S.C. 154(b) by 0 days.

(21) Appl. No.: **11/683,004**

(22) Filed: **Mar. 7, 2007**

(65) **Prior Publication Data**

US 2007/0145862 A1 Jun. 28, 2007

**Related U.S. Application Data**

(63) Continuation of application No. PCT/JP2005/015185, filed on Aug. 22, 2005.

(30) **Foreign Application Priority Data**

Sep. 10, 2004 (JP) ..... 2004-263952

(51) **Int. Cl.**

**G01N 29/036** (2006.01)

**H01L 41/08** (2006.01)

(52) **U.S. Cl.** ..... **73/24.06; 73/24.01; 73/61.75; 73/64.53; 310/313 D; 310/313 B; 310/313 R**

(57) **ABSTRACT**

A sensor for detecting an analyte in liquid includes a base substrate provided with openings and electrode lands on one surface thereof and SAW elements each provided with a sensing portion having at least one IDT electrode on one side. The SAW elements are mounted on the base substrate with bump electrodes by a flip-chip bonding method so that the sensing portions of the SAW elements face the openings of the base substrate. At least one of the sensing portions is coated with a reaction membrane which binds to an analyte.

**11 Claims, 16 Drawing Sheets**

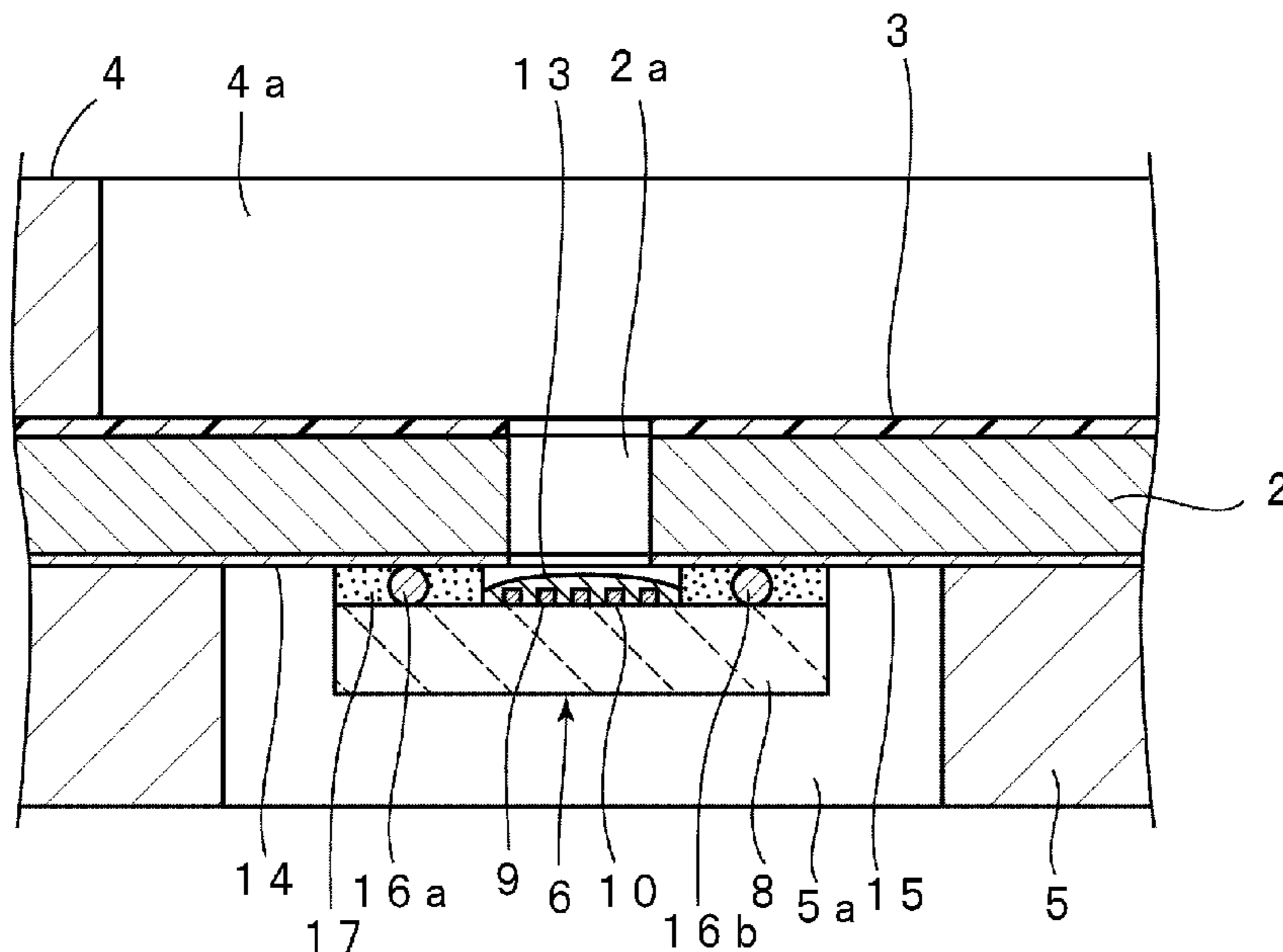

# US 7,389,673 B2

Page 2

---

## U.S. PATENT DOCUMENTS

5,220,234 A \* 6/1993 Flory et al. .... 310/313 D  
5,283,037 A \* 2/1994 Baer et al. .... 422/82.01  
6,404,110 B1 \* 6/2002 Nakashima et al. .... 310/364  
6,626,026 B2 \* 9/2003 Banda et al. .... 73/24.01  
2005/0029906 A1 \* 2/2005 Miyaji ..... 310/348

## FOREIGN PATENT DOCUMENTS

JP 02-238357 A 9/1990  
JP 05-045339 A 2/1993  
JP 05045338 A \* 2/1993  
JP 05-322736 A 12/1993  
JP 06-053773 A 2/1994  
JP 06-133759 A 5/1994

JP 06194346 A \* 7/1994  
JP 09243618 A \* 9/1997  
JP 10090270 A \* 4/1998  
JP 2764108 B2 6/1998  
JP 2002-283293 A 10/2002  
JP 2003-502616 A 1/2003  
JP 2003115744 A \* 4/2003  
JP 2003139746 A \* 5/2003  
JP 2003294713 A \* 10/2003  
JP 2004-045358 A 2/2004  
JP 2004-147220 A 5/2004  
JP 2004-153412 A 5/2004  
JP 2004-200908 A 7/2004

\* cited by examiner

FIG. 1

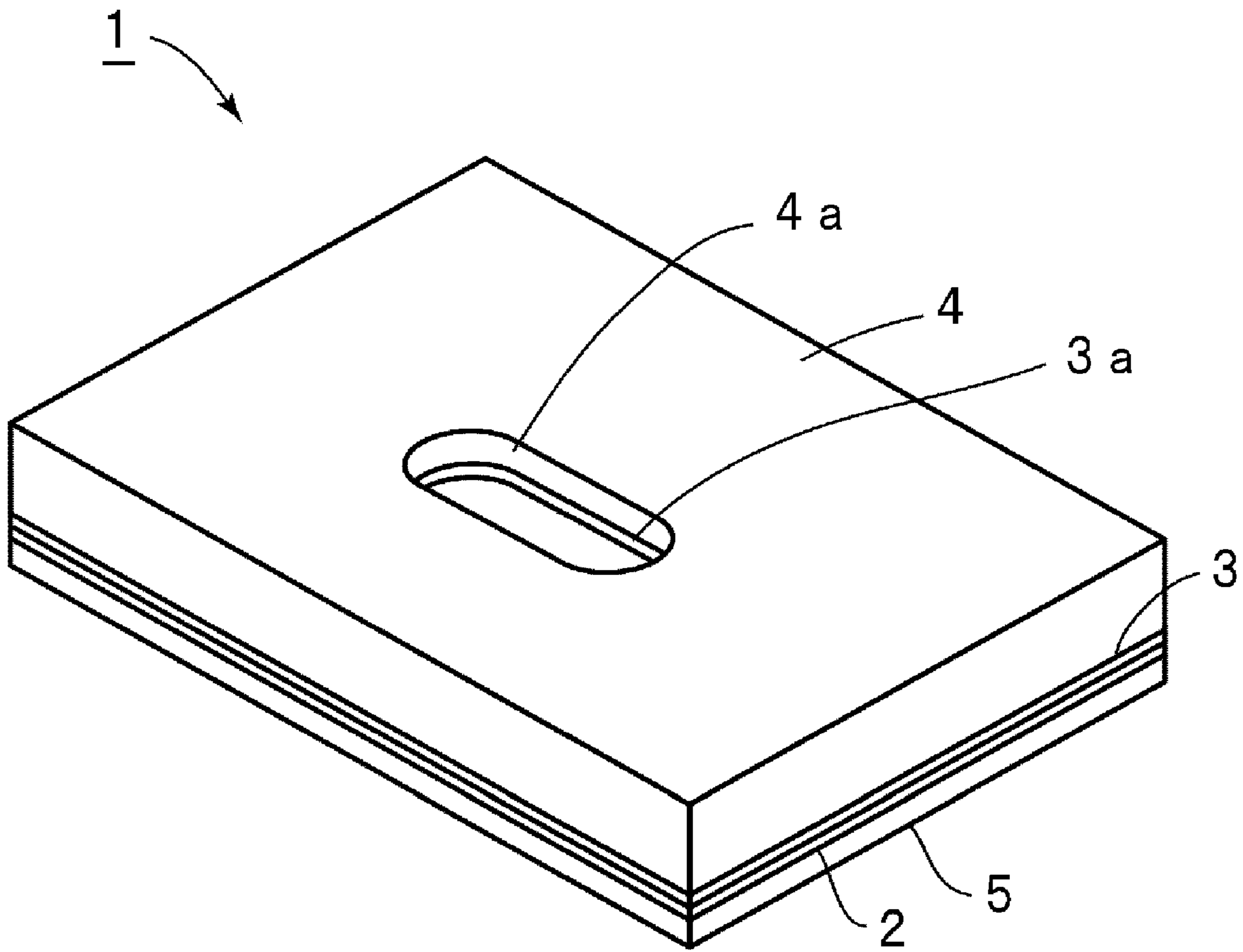

FIG. 2

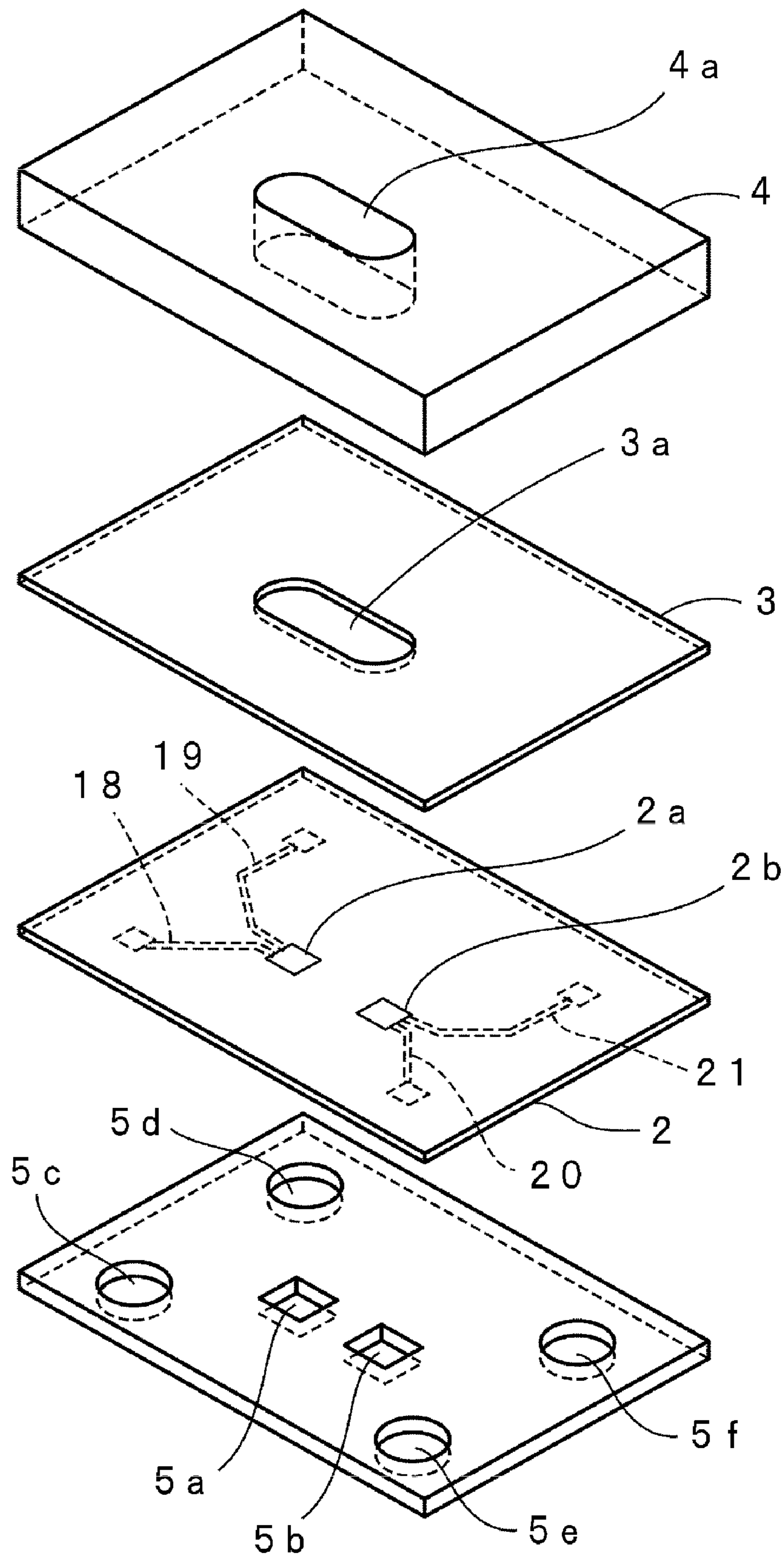

FIG. 3A

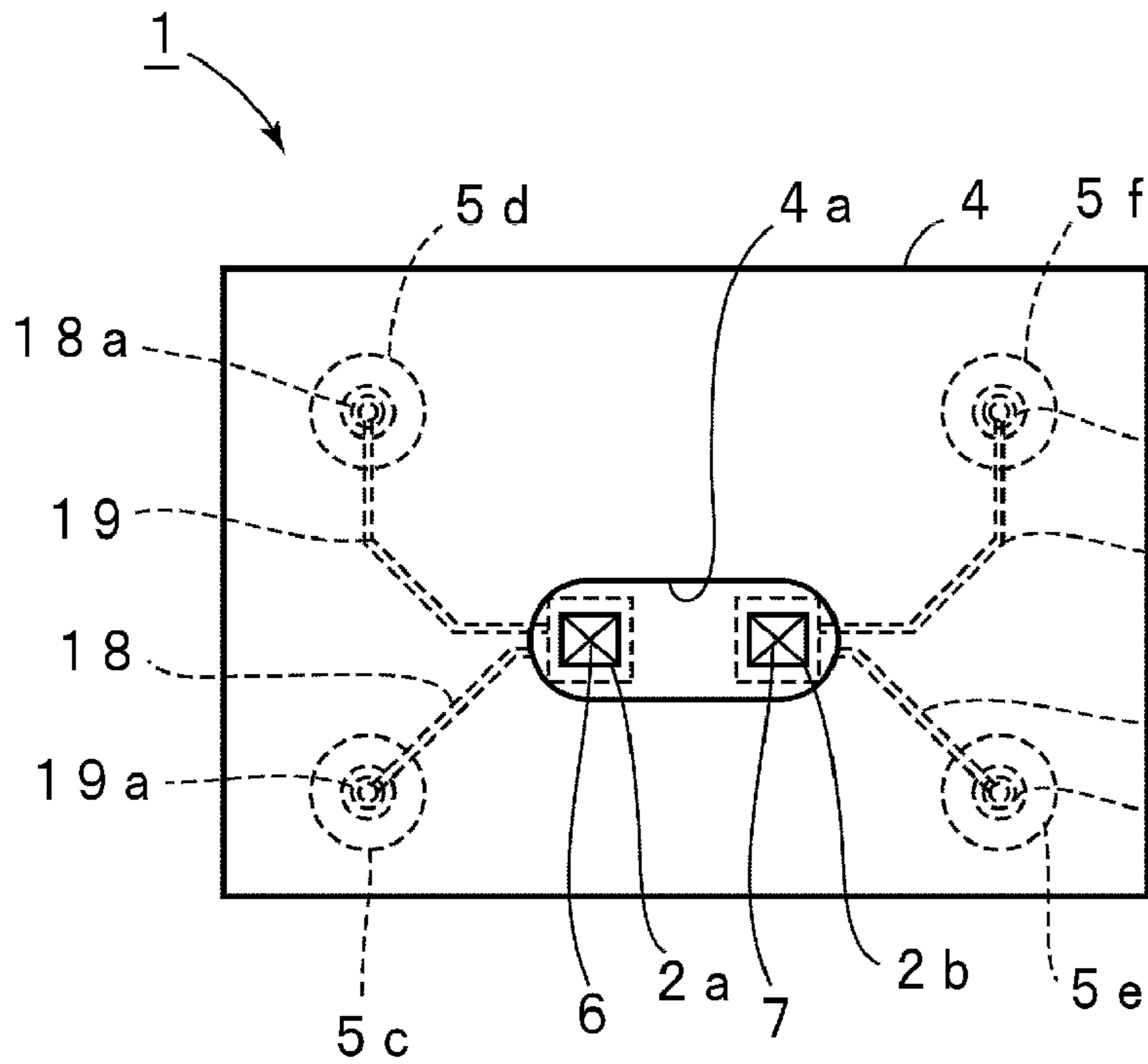

FIG. 3B

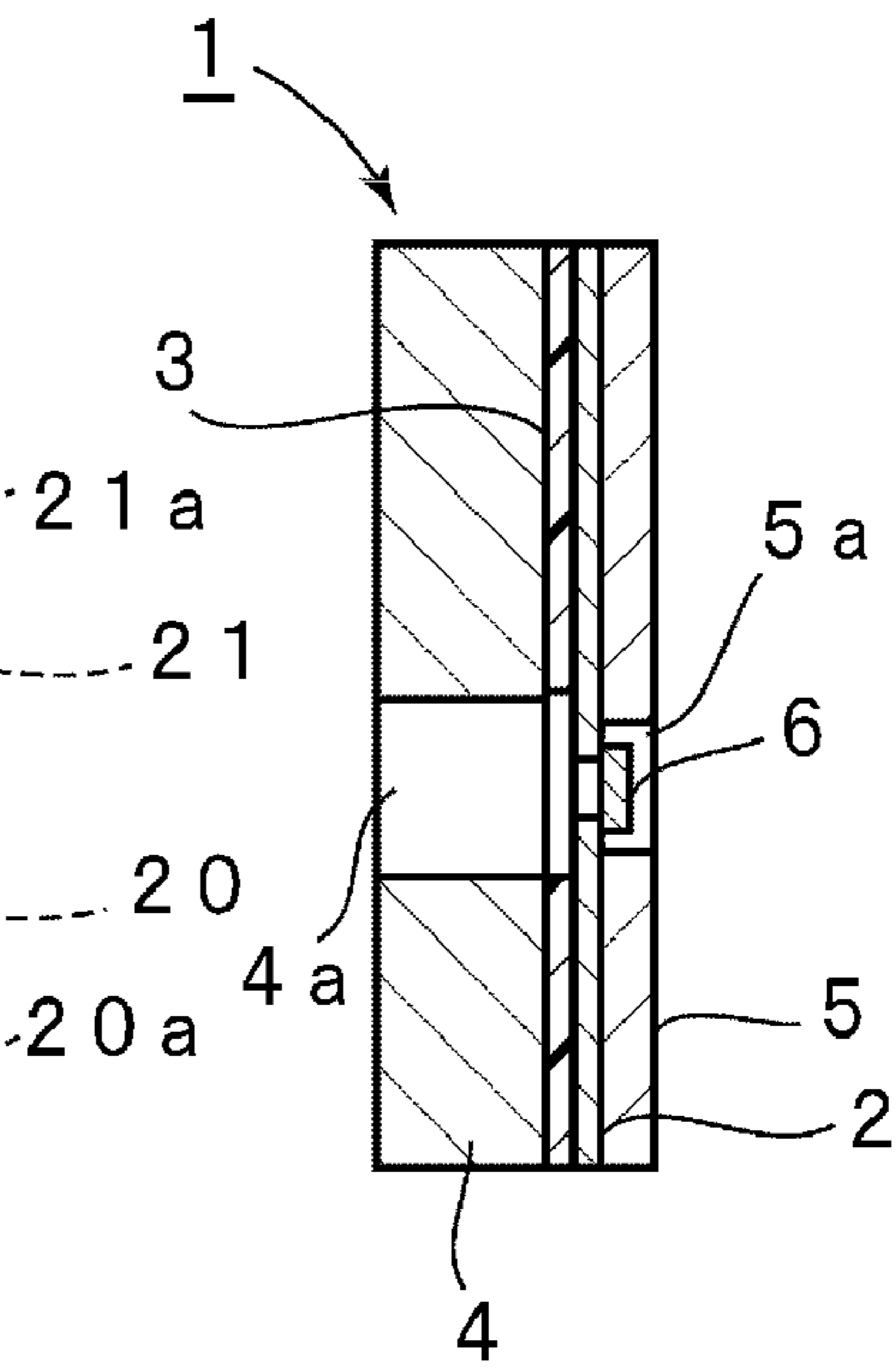

FIG. 3C

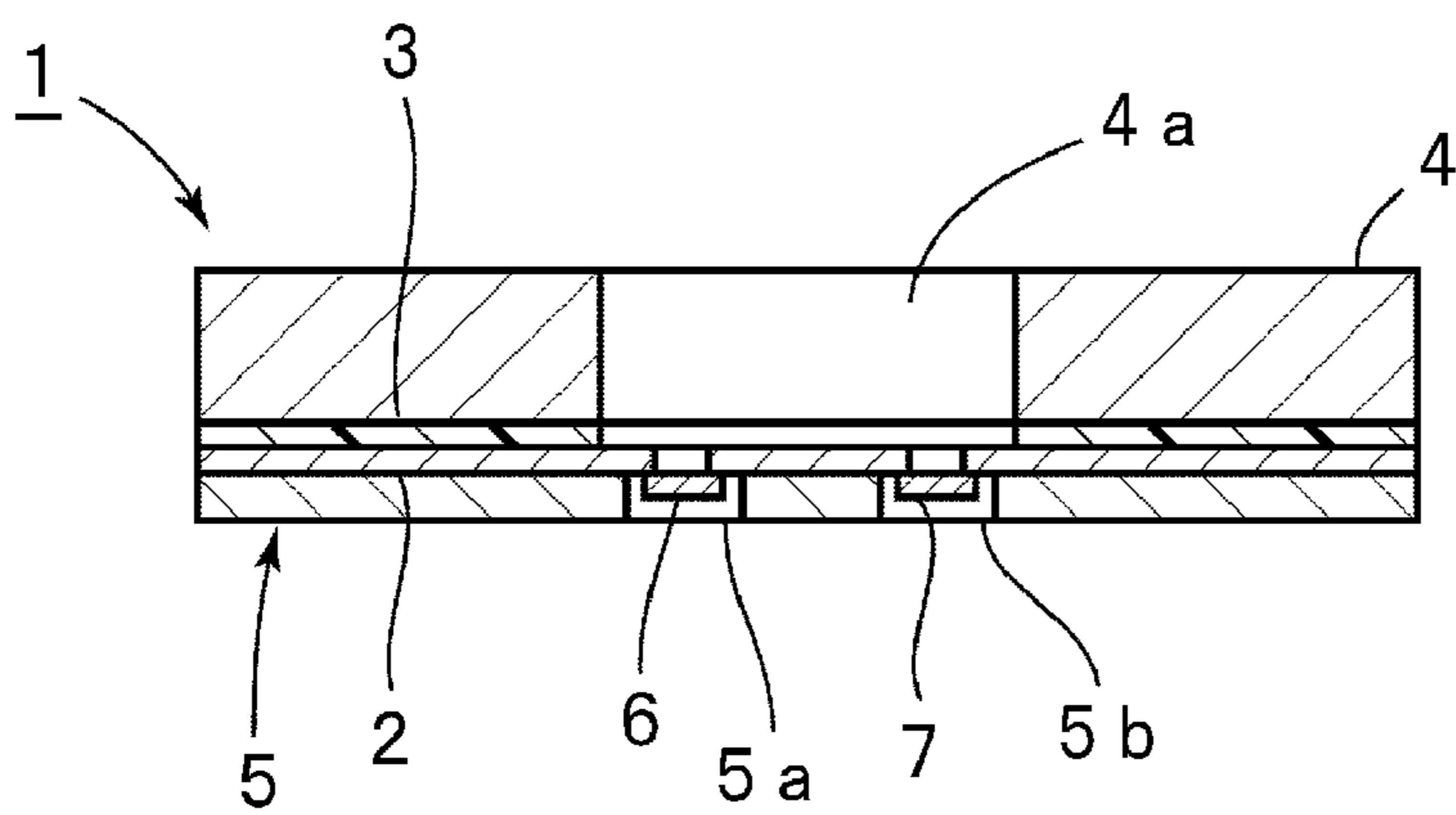



FIG. 4A

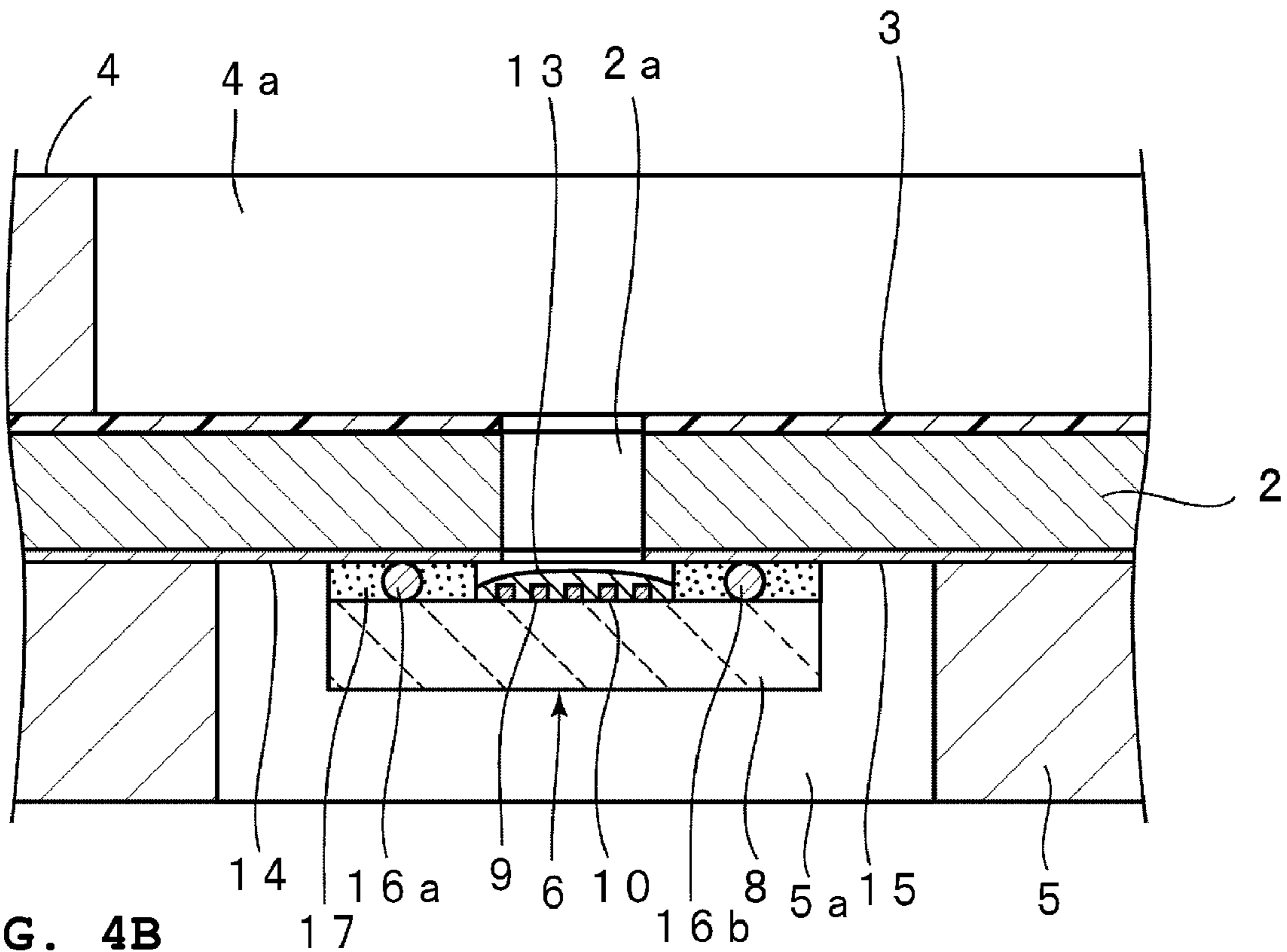
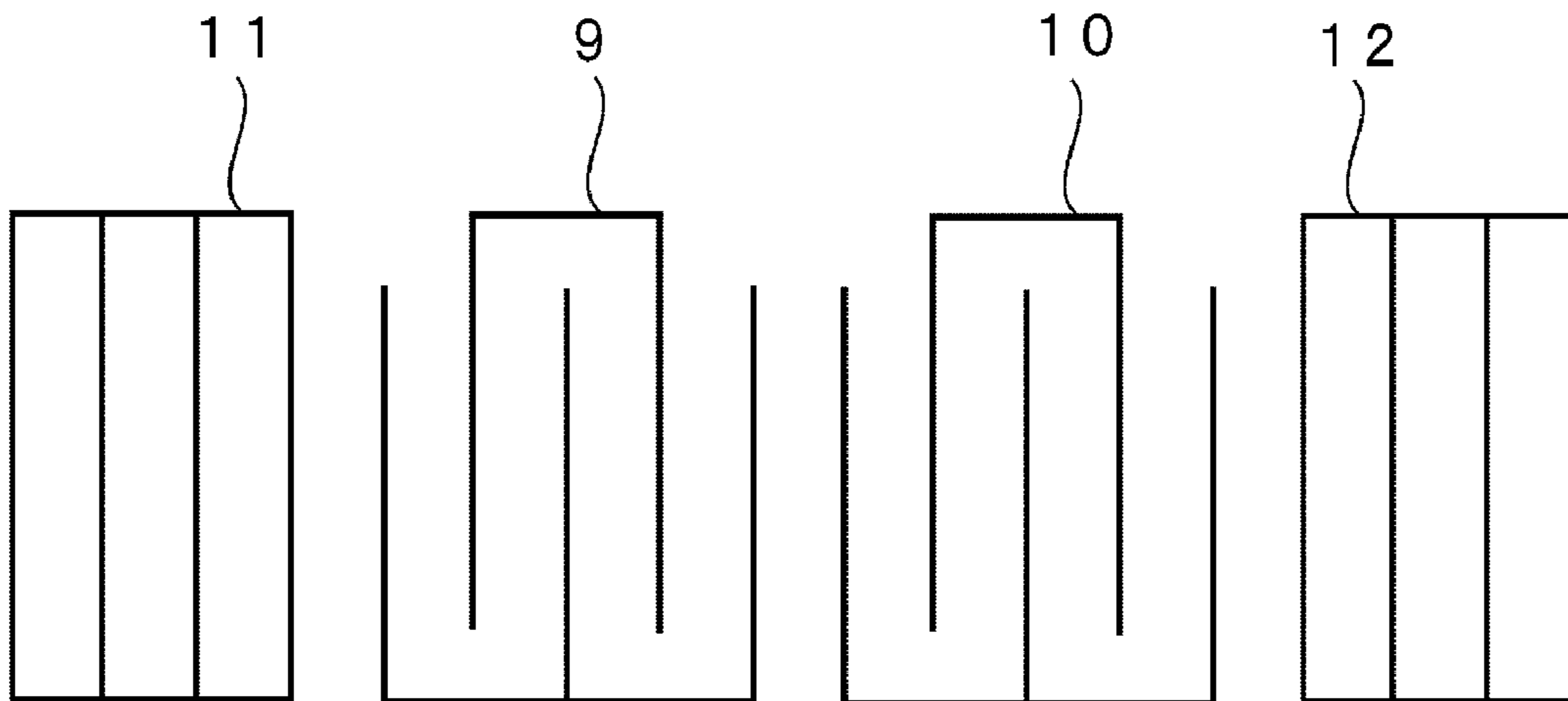
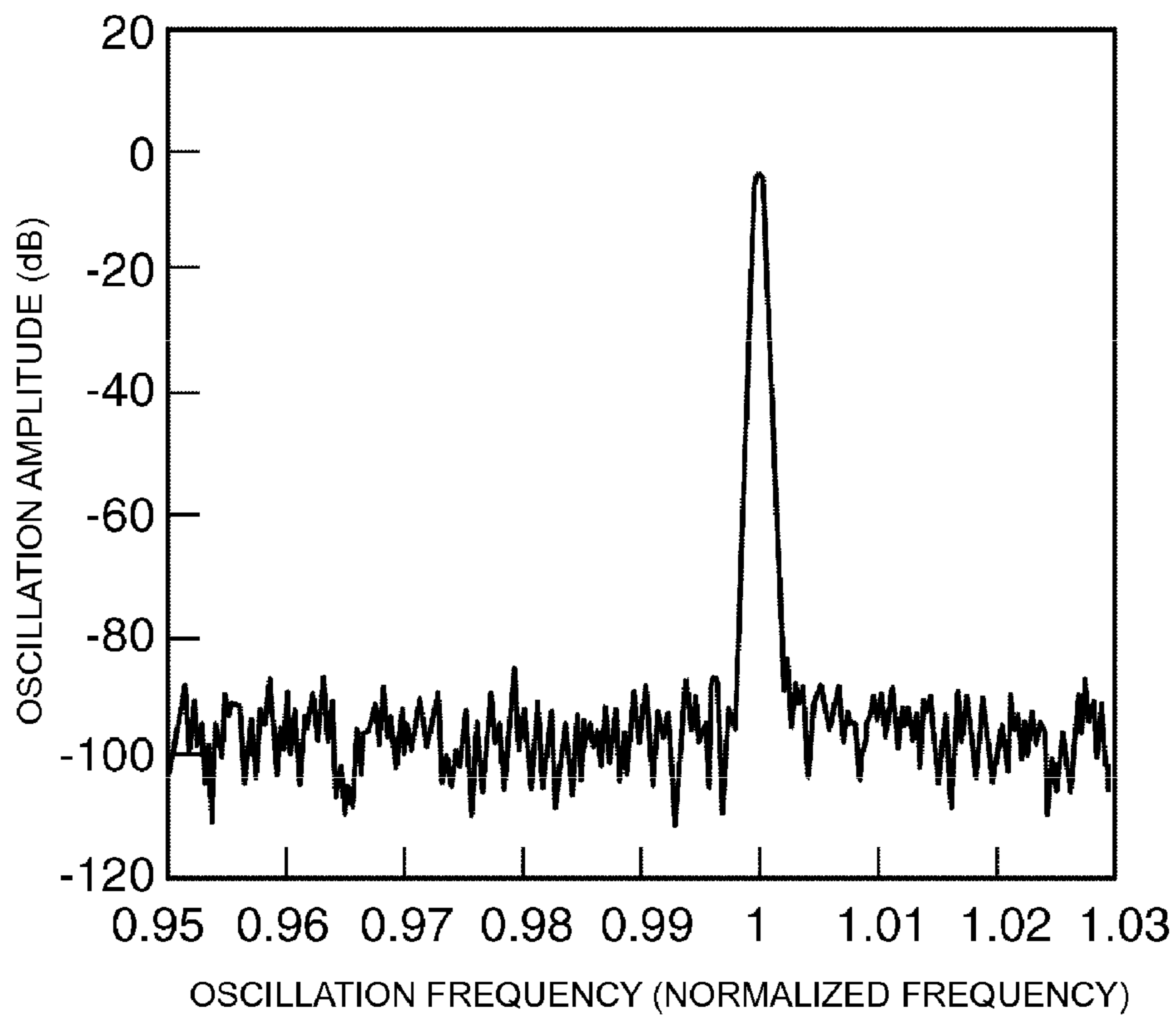

FIG. 4B



**FIG. 5A**



**FIG. 5B**

**PRIOR ART**

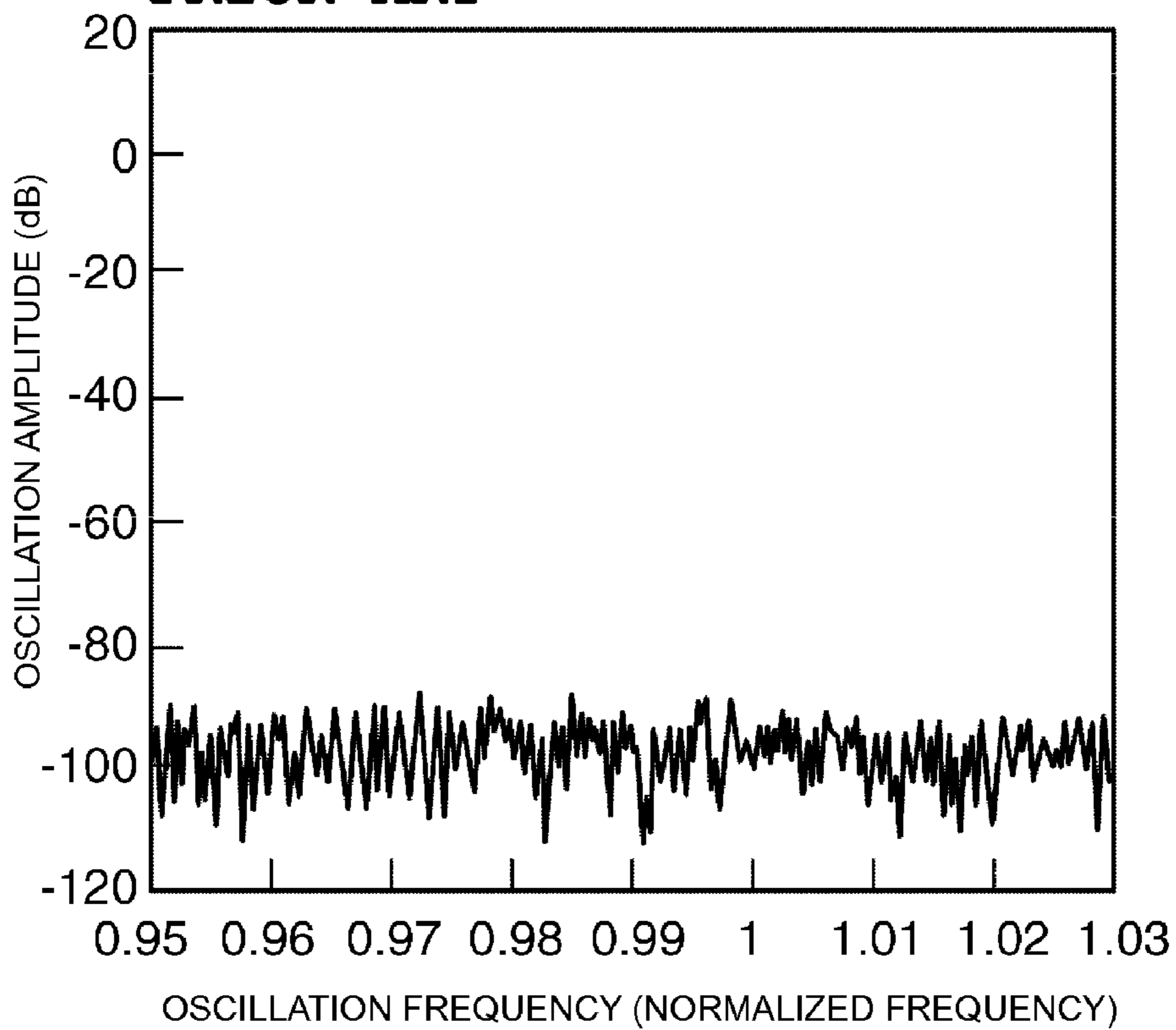

FIG. 6

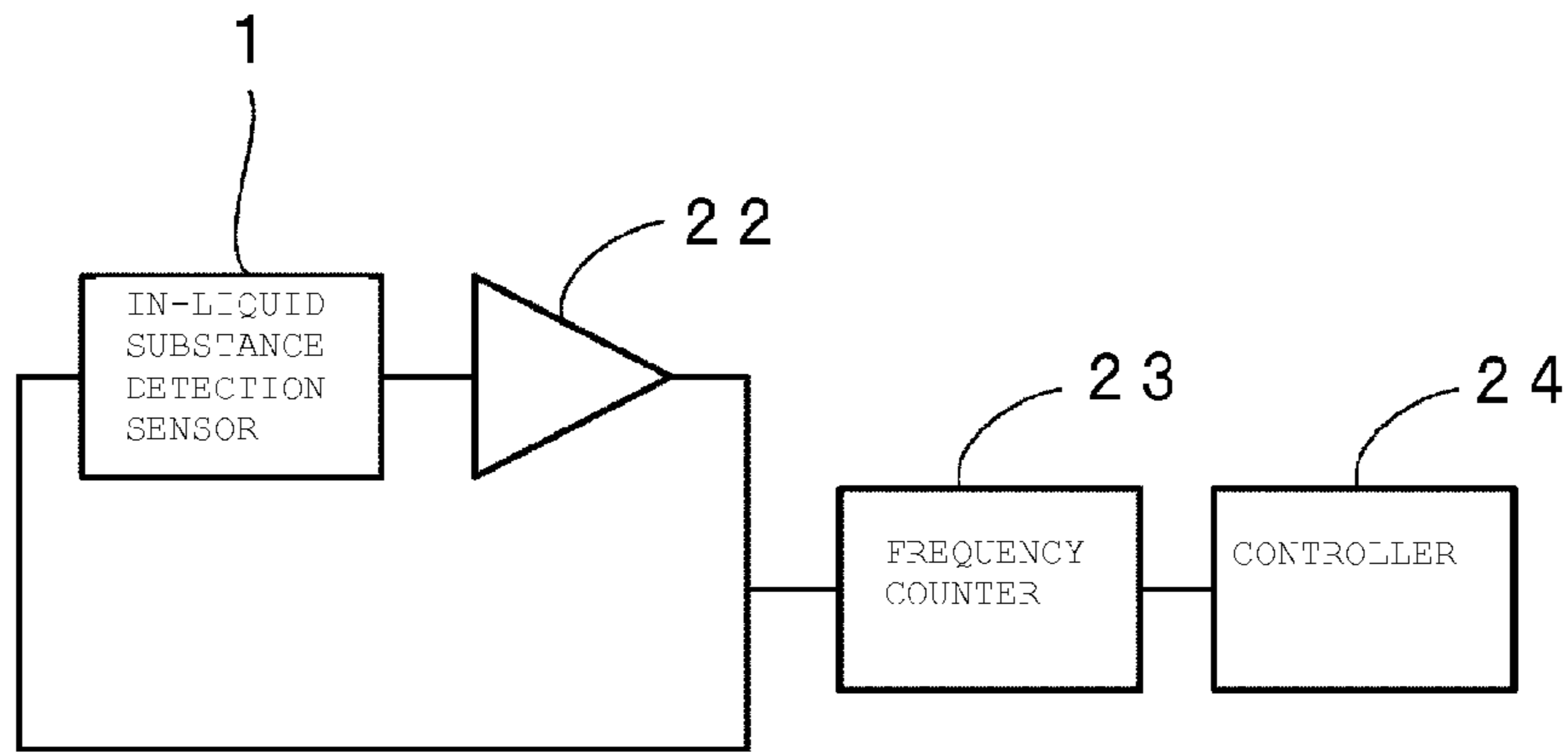

FIG. 7

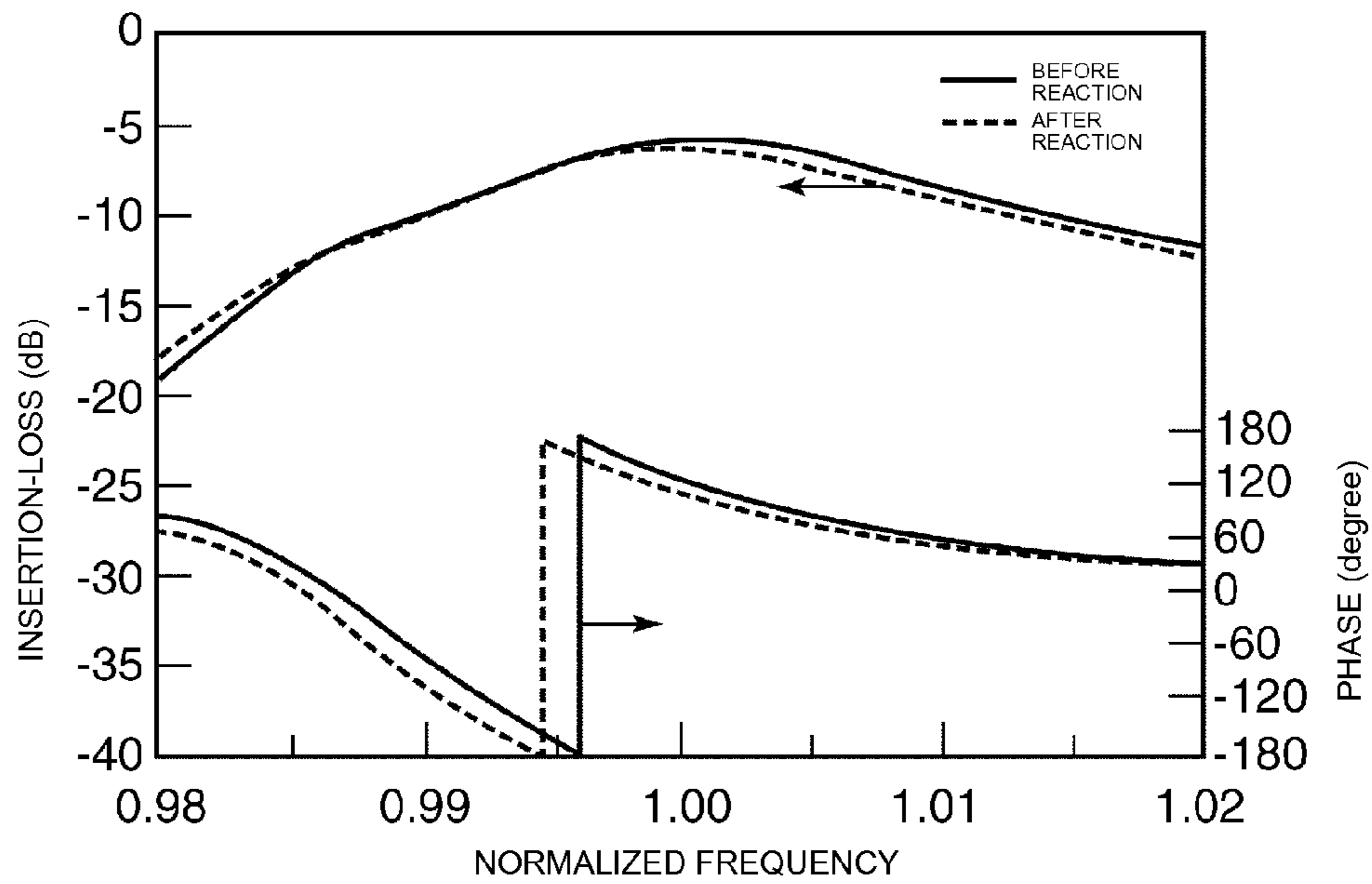
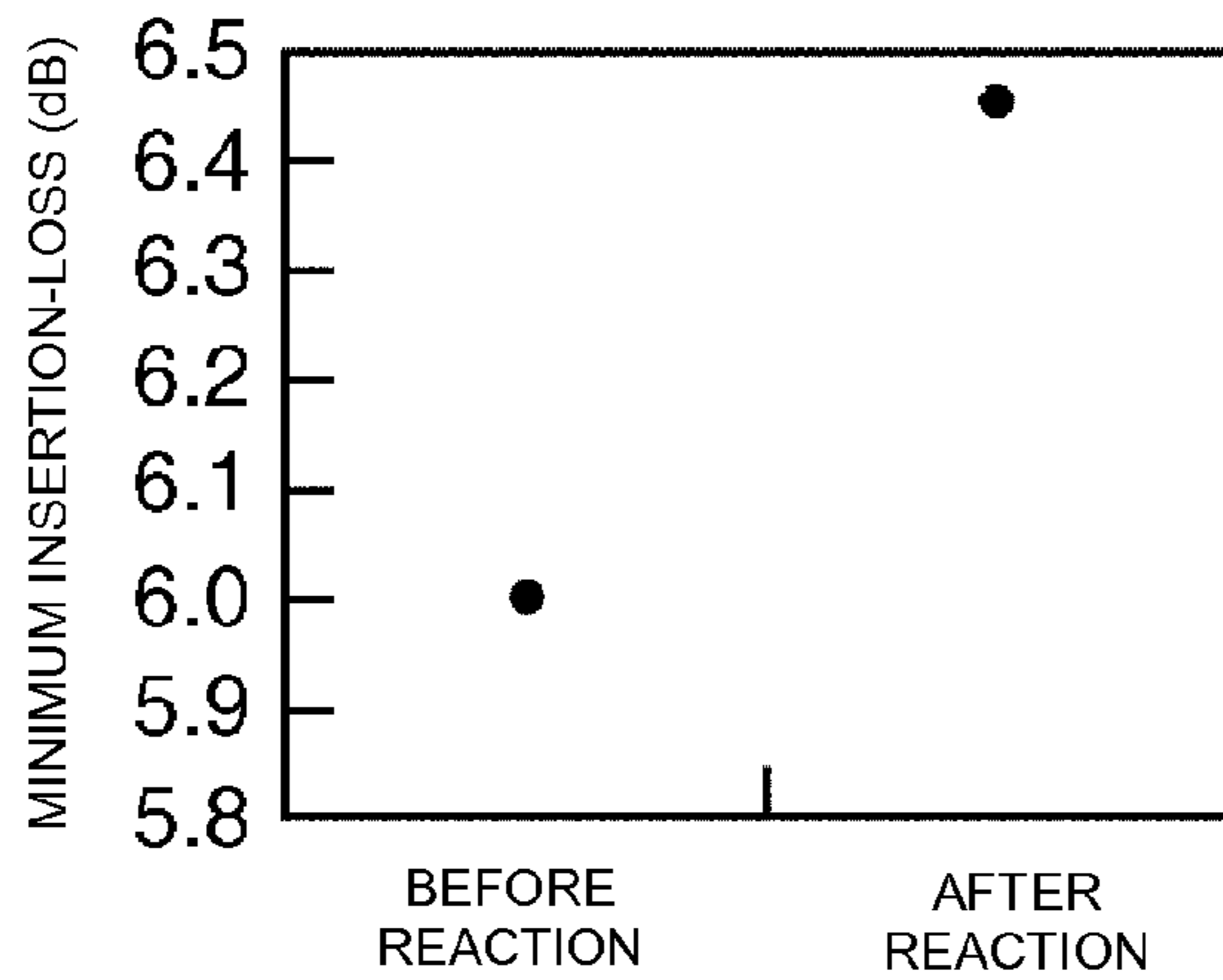
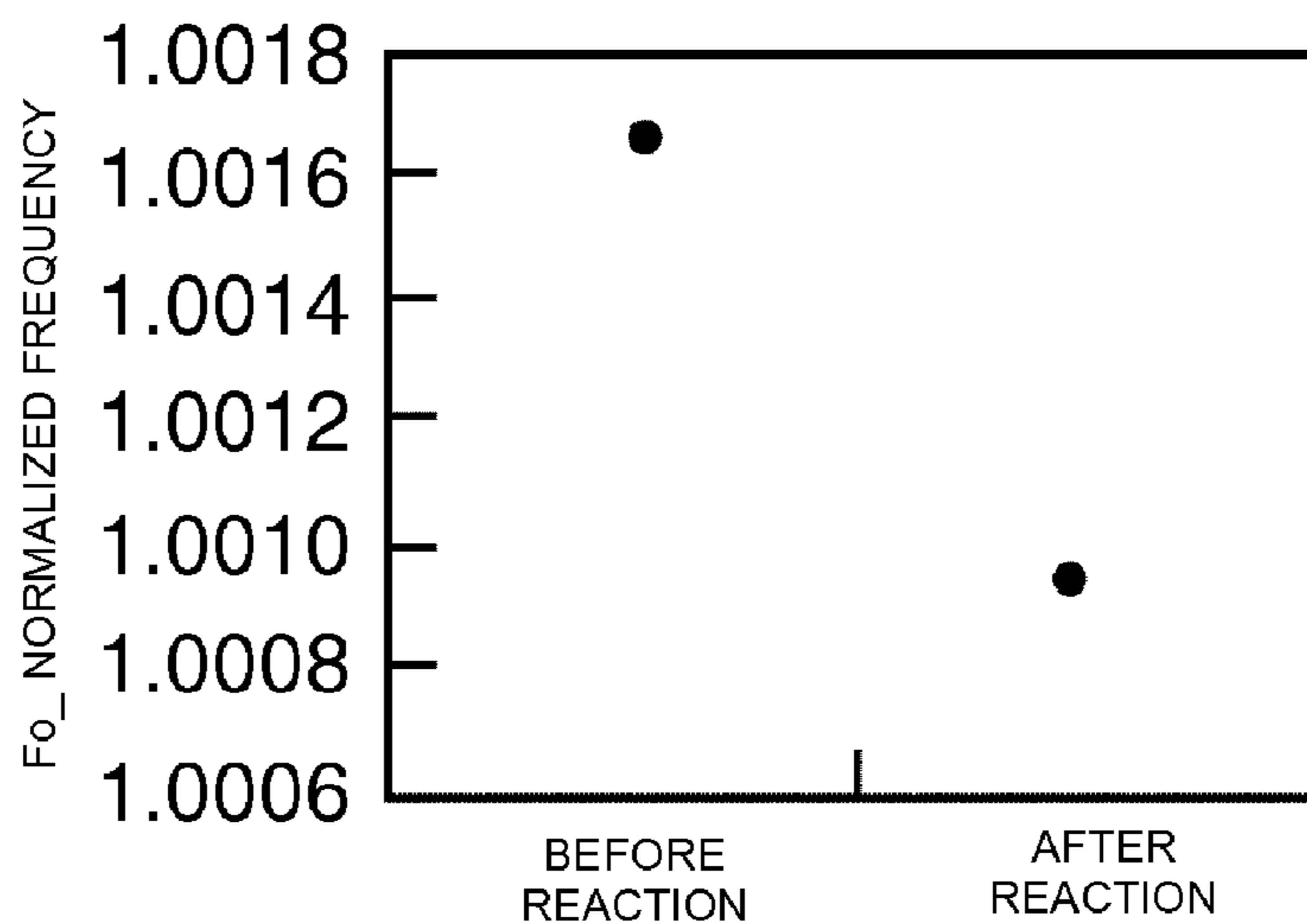

FIG. 8

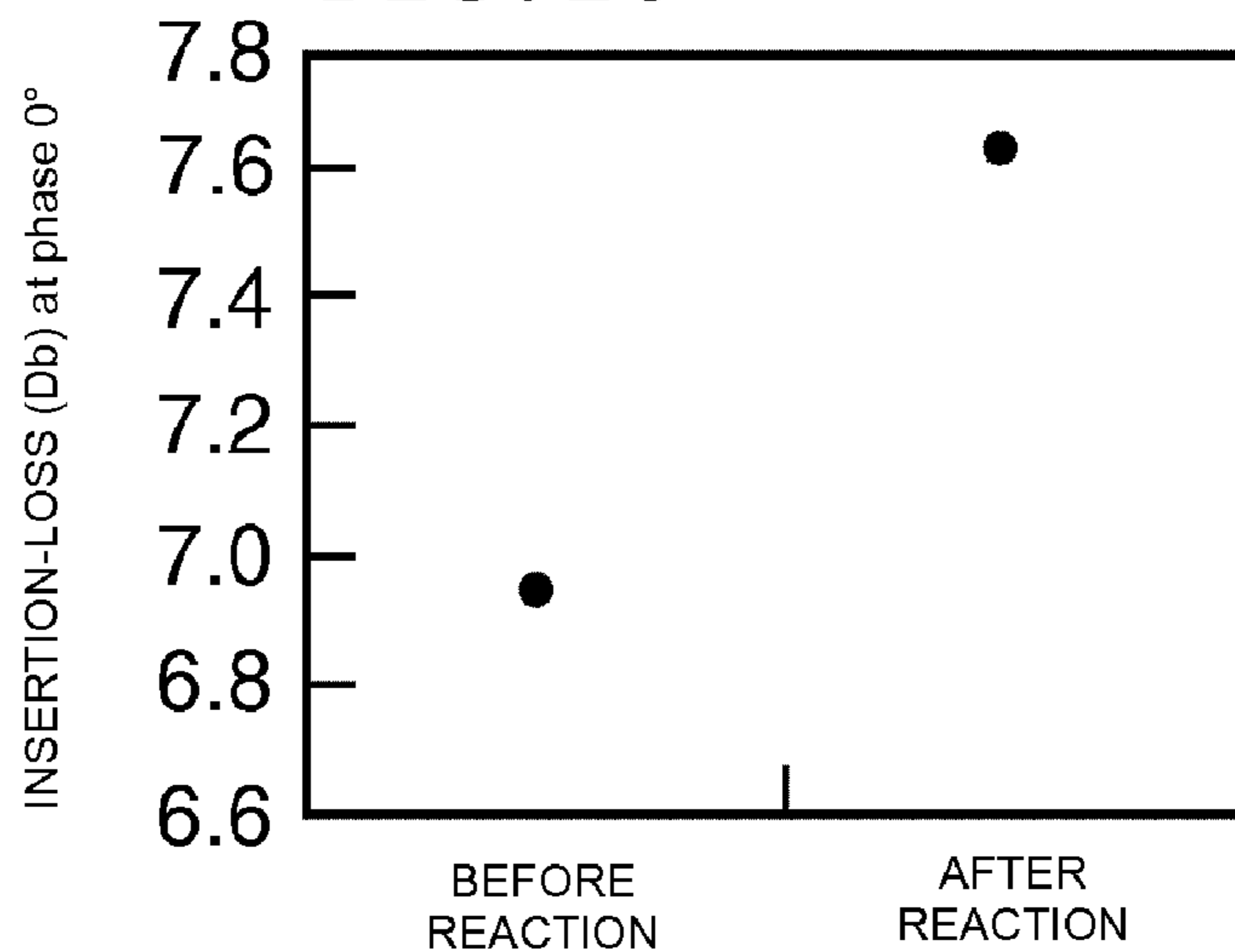



**FIG. 9**



**FIG. 10**



**FIG. 11**

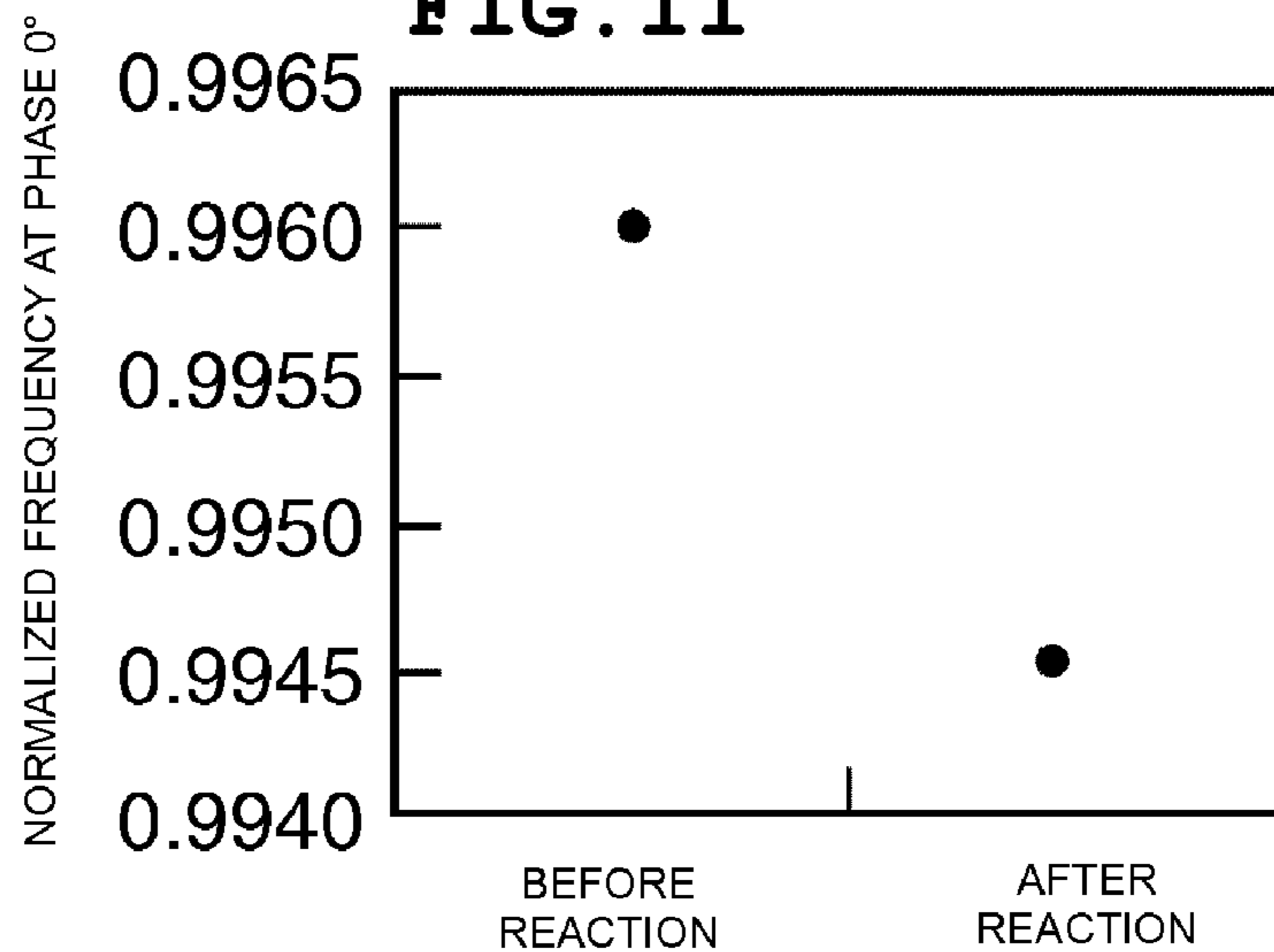

FIG. 12

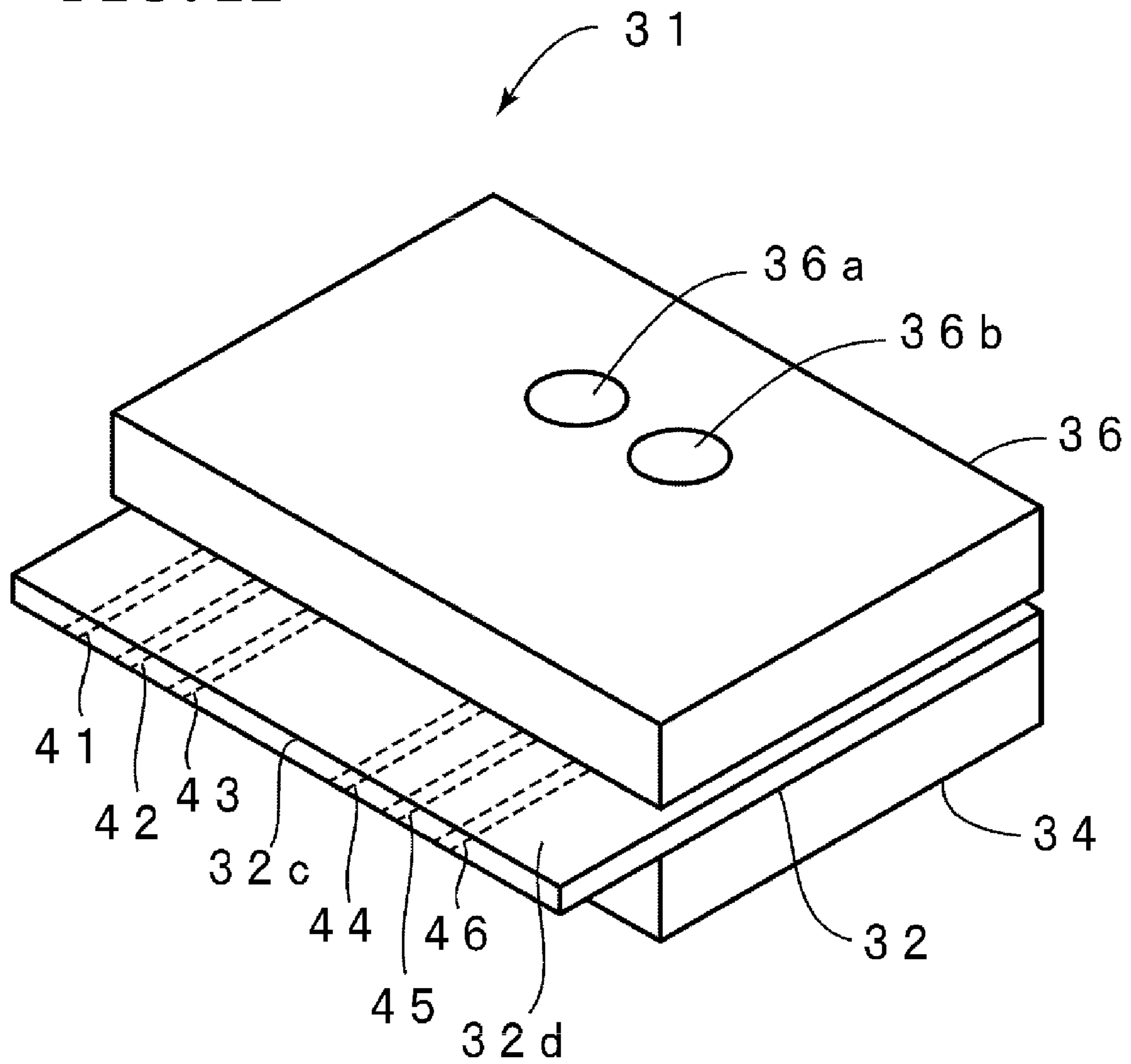

FIG. 13

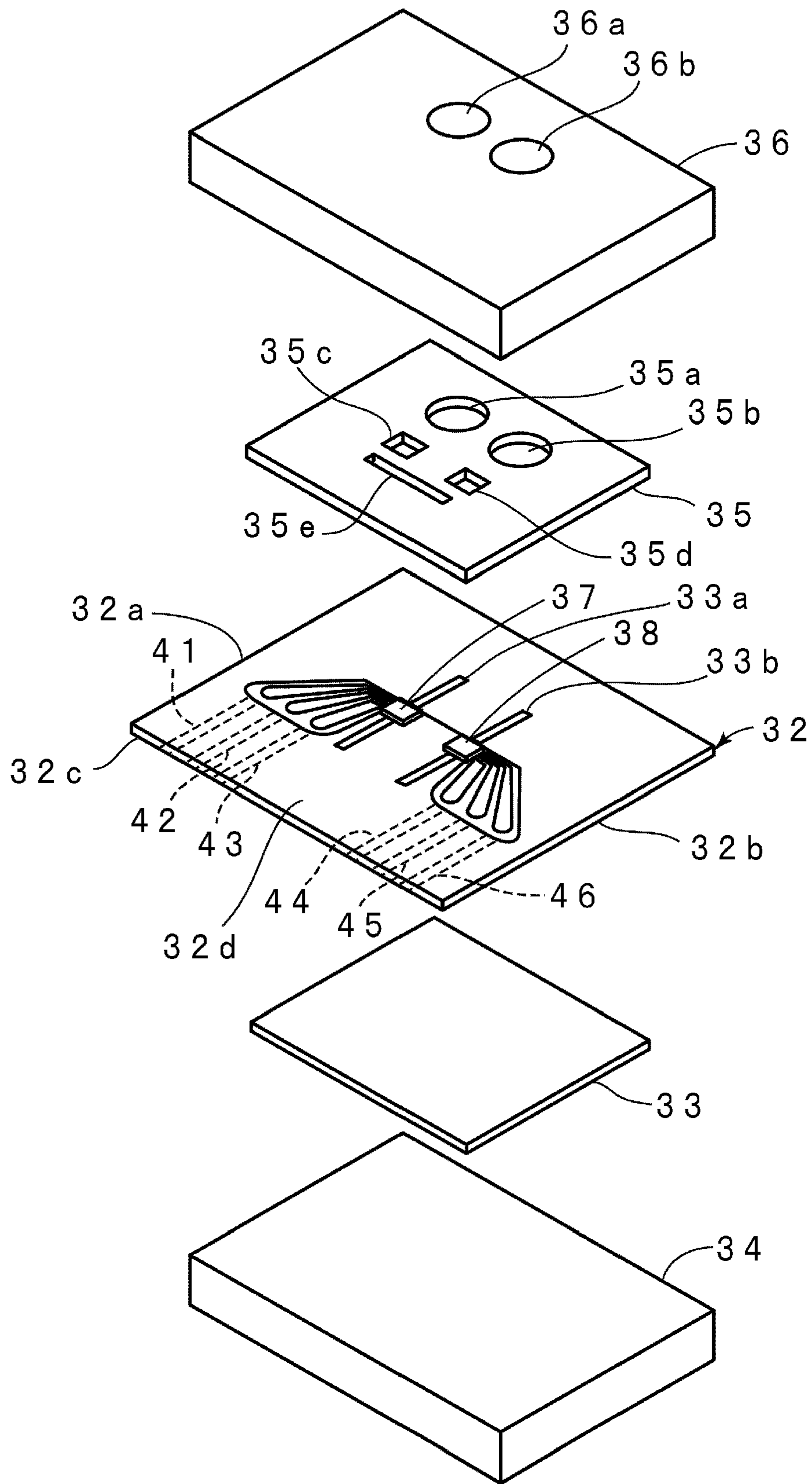

FIG. 14

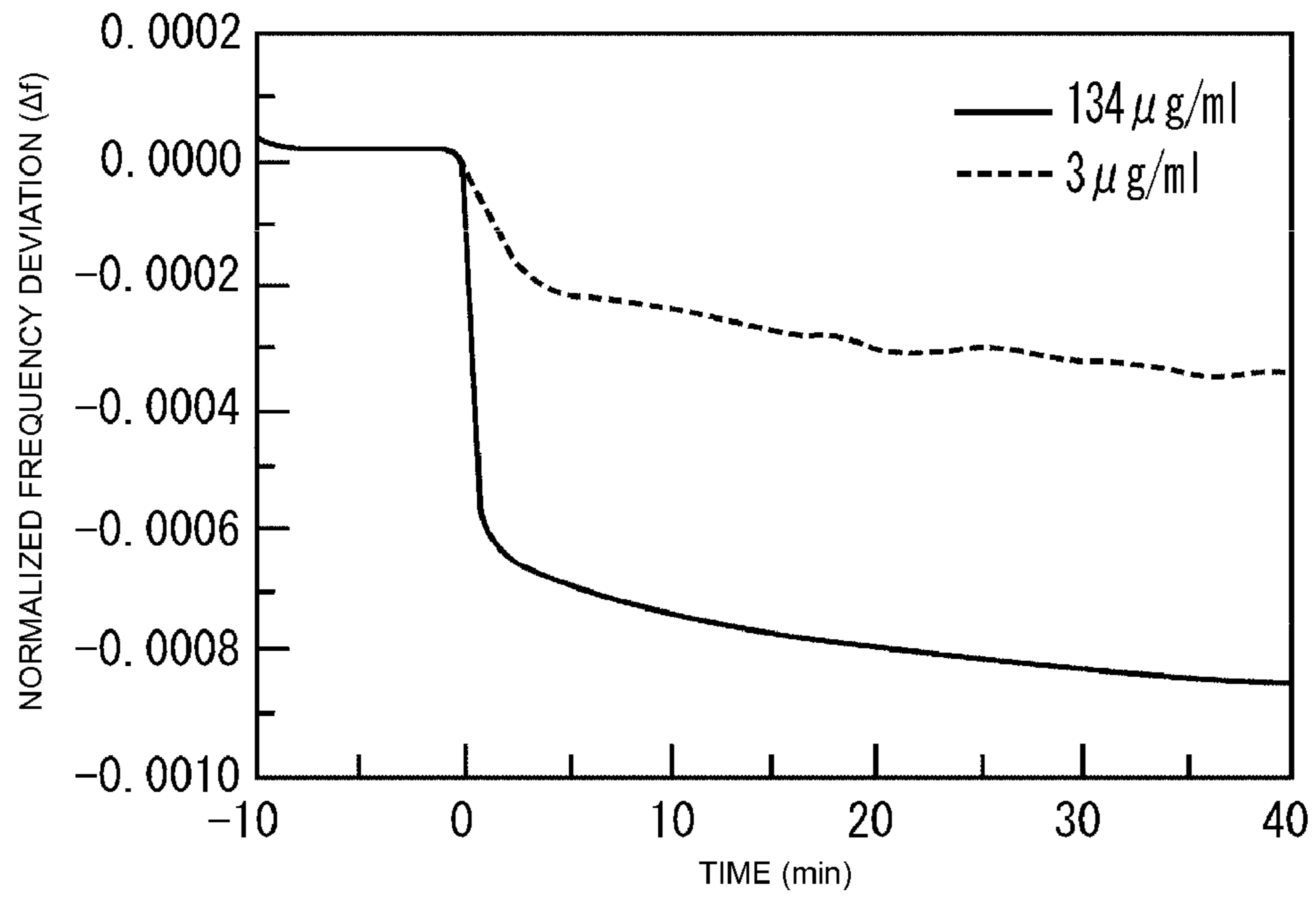

FIG. 15

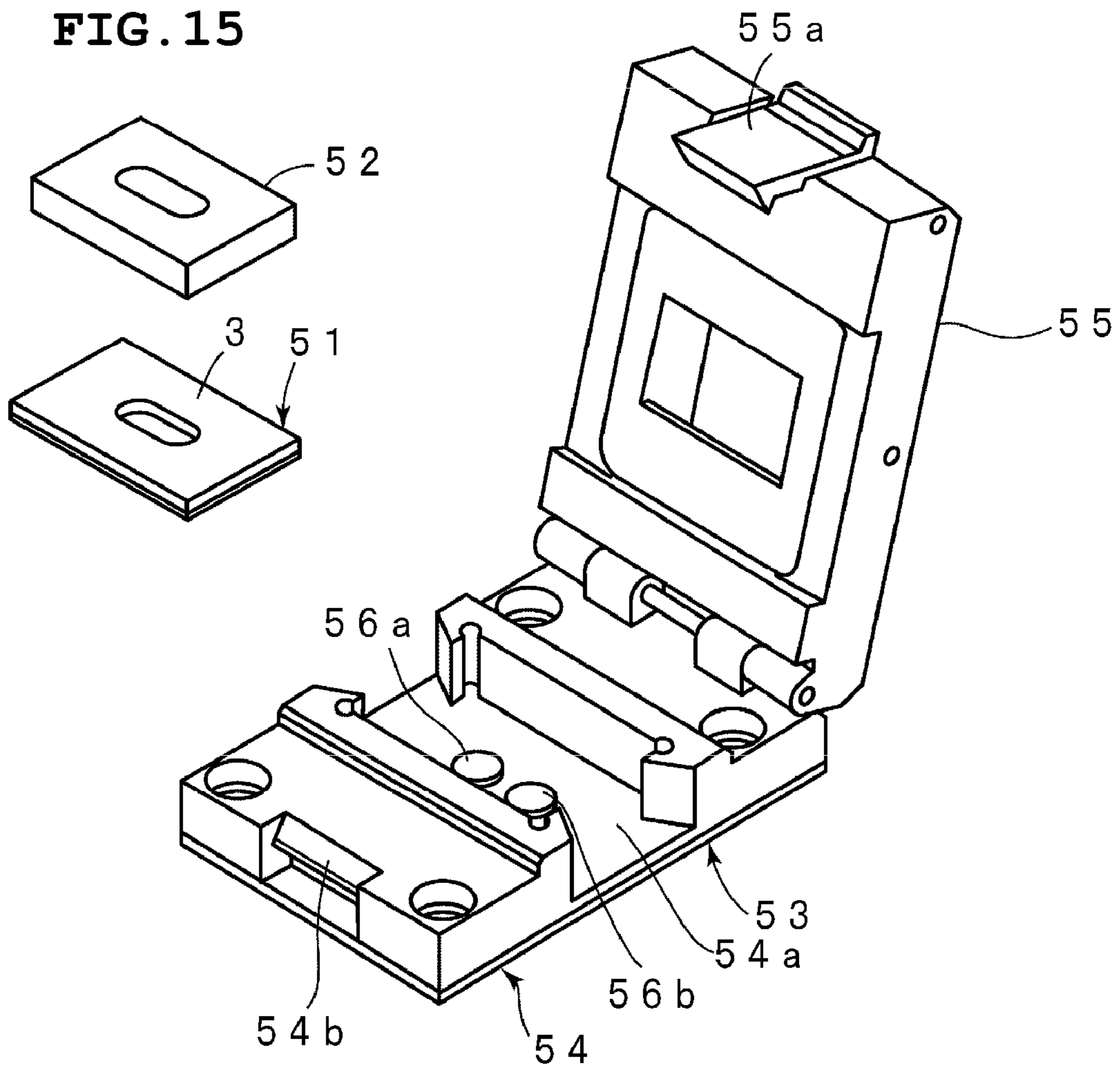

FIG. 16

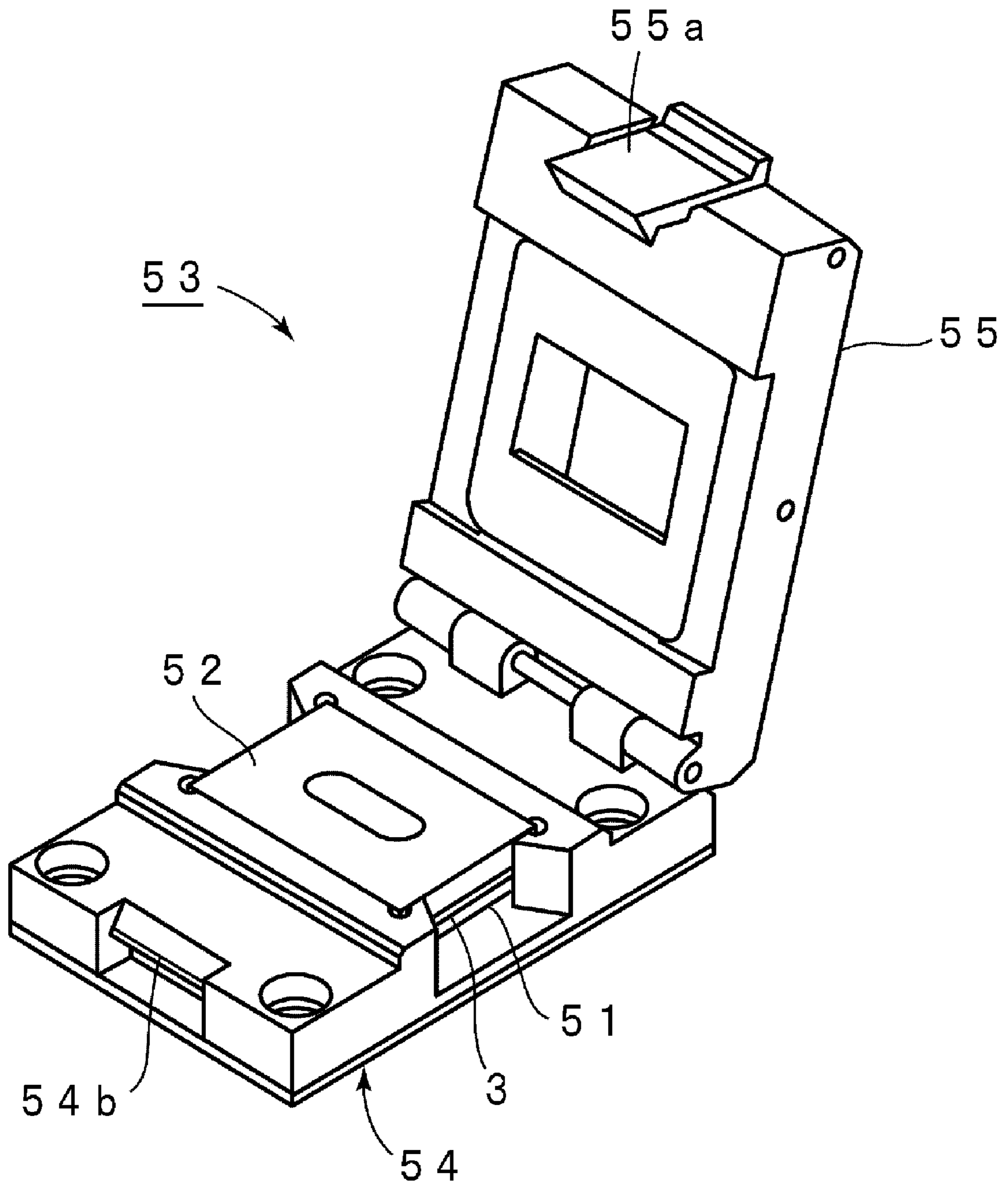



FIG. 17

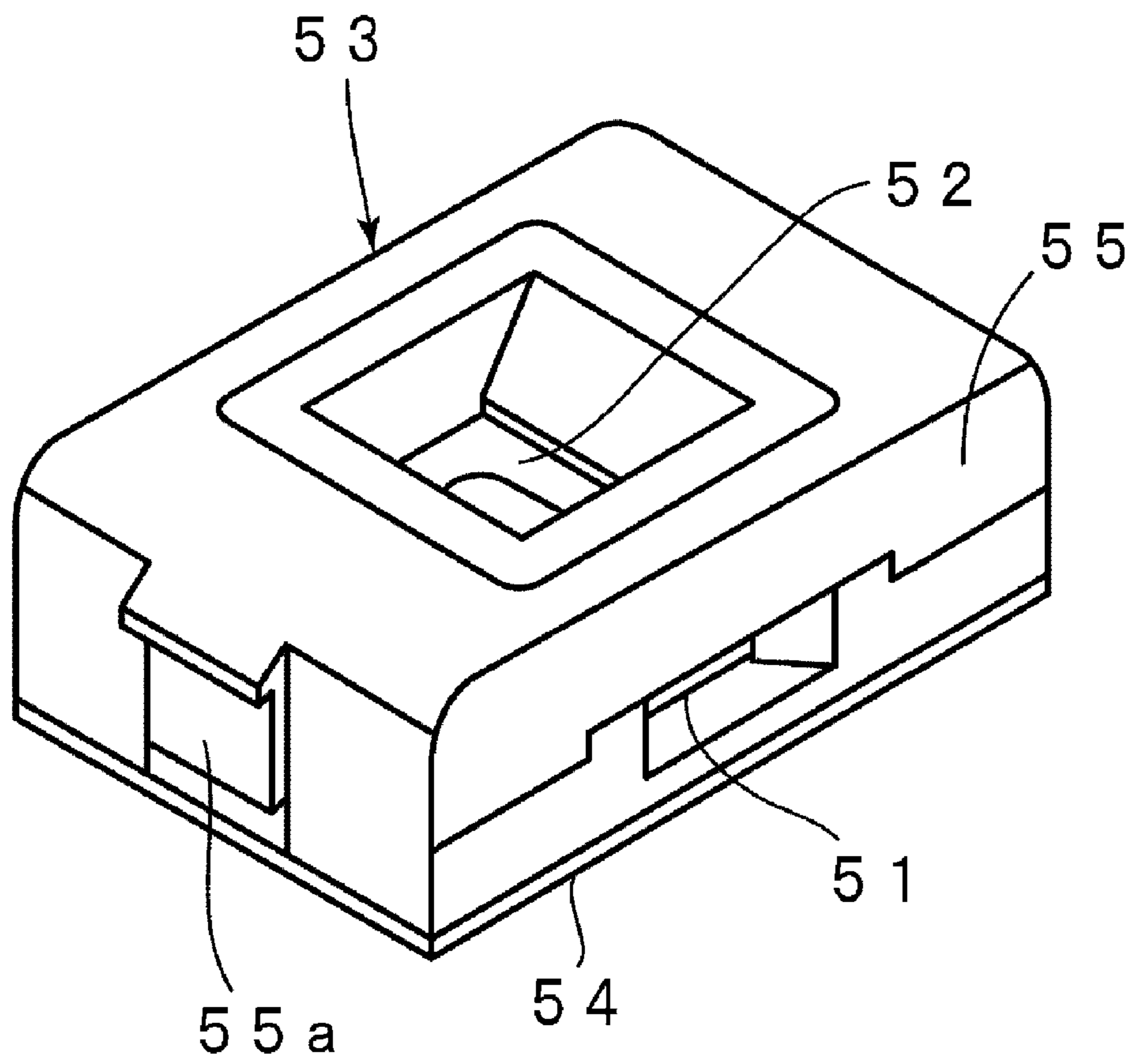

FIG. 18

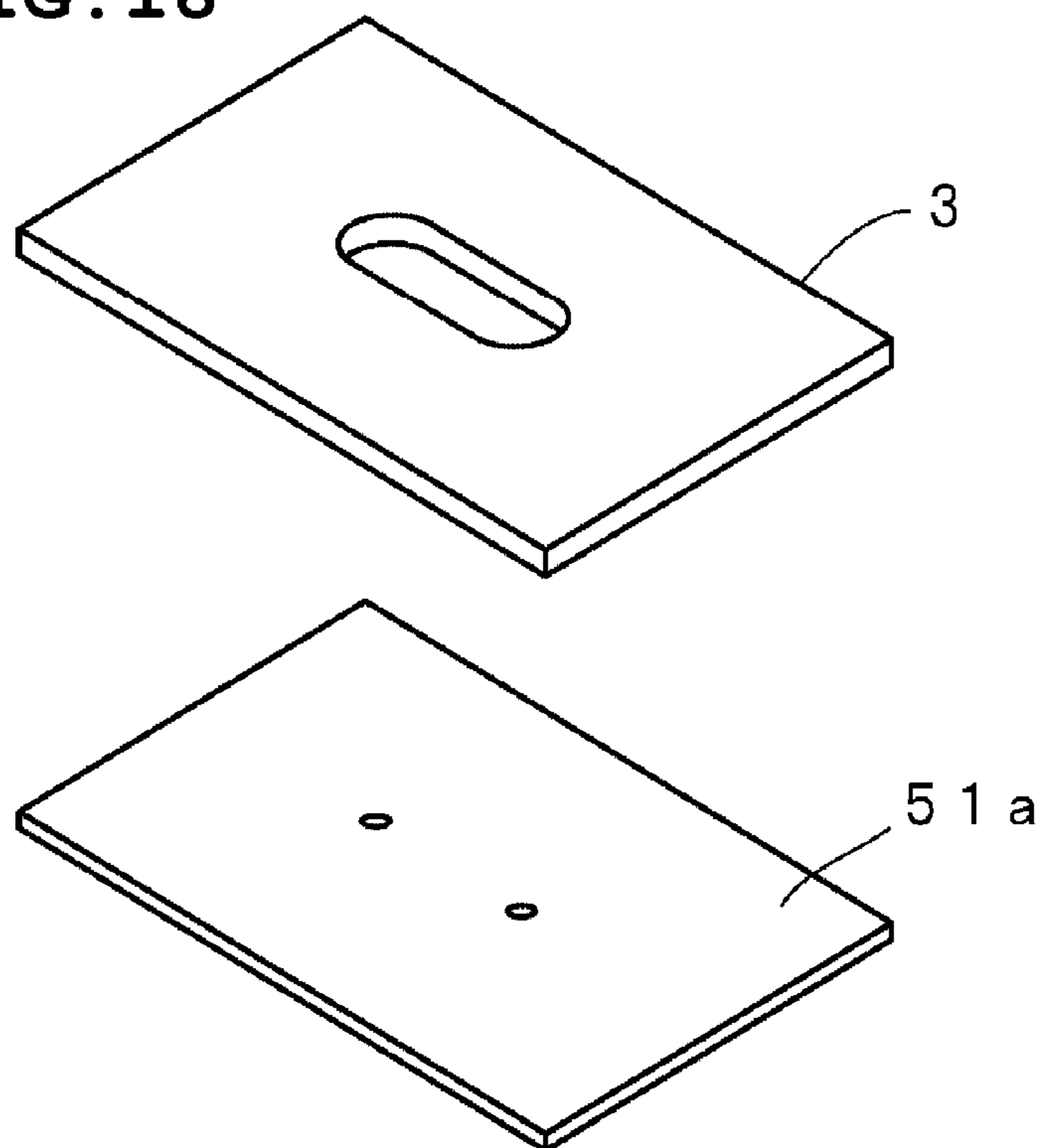

FIG. 19

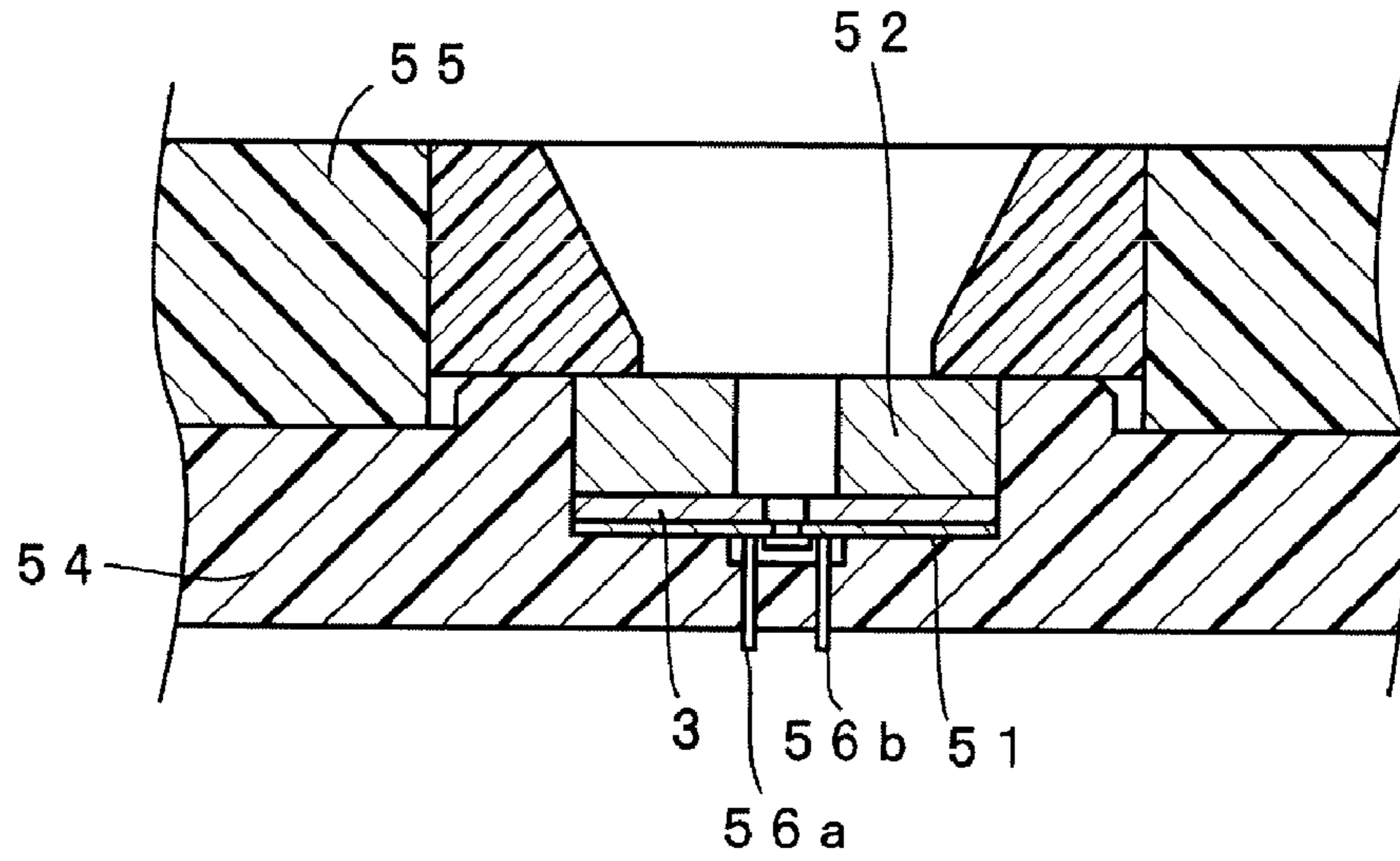

FIG. 20

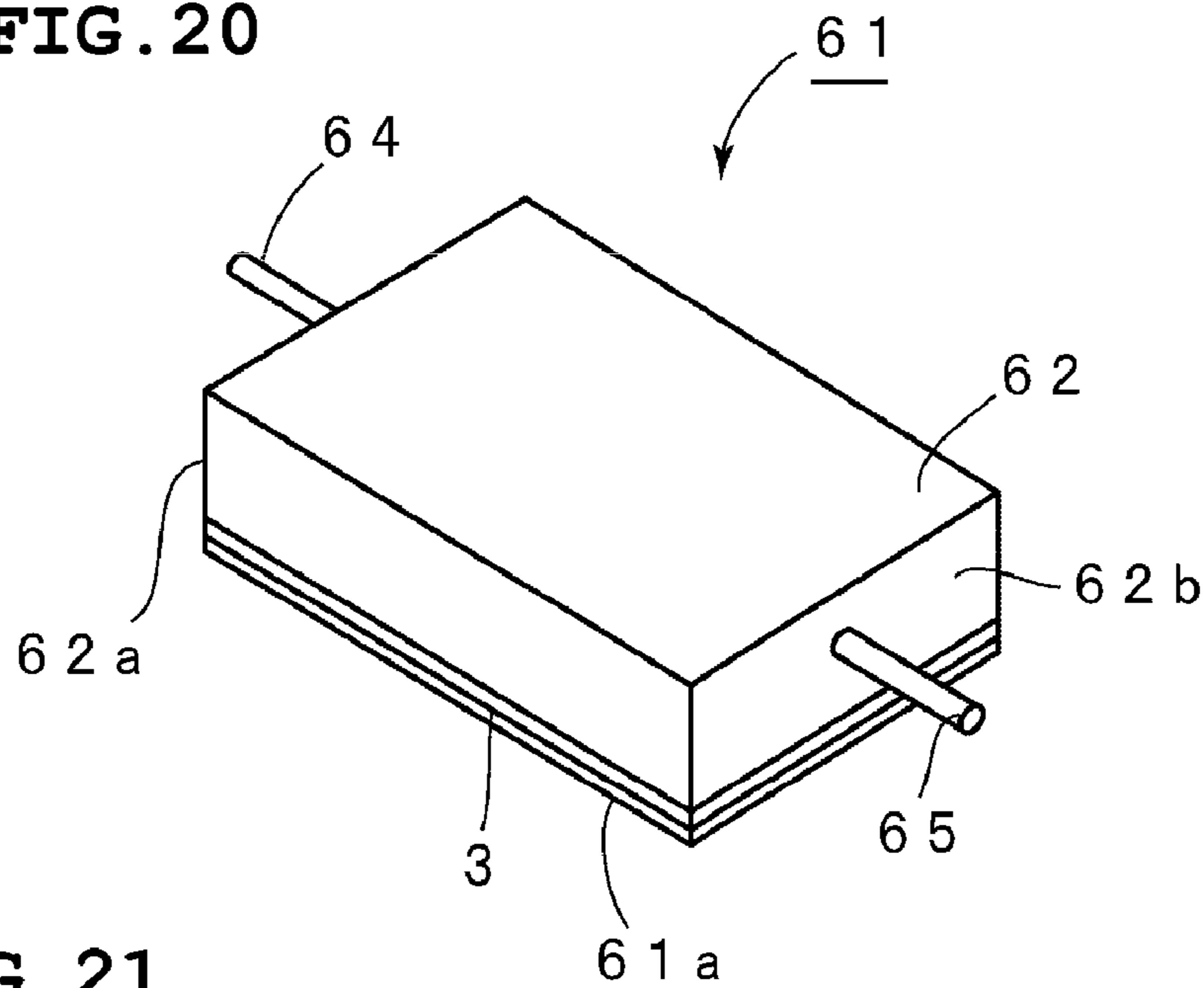
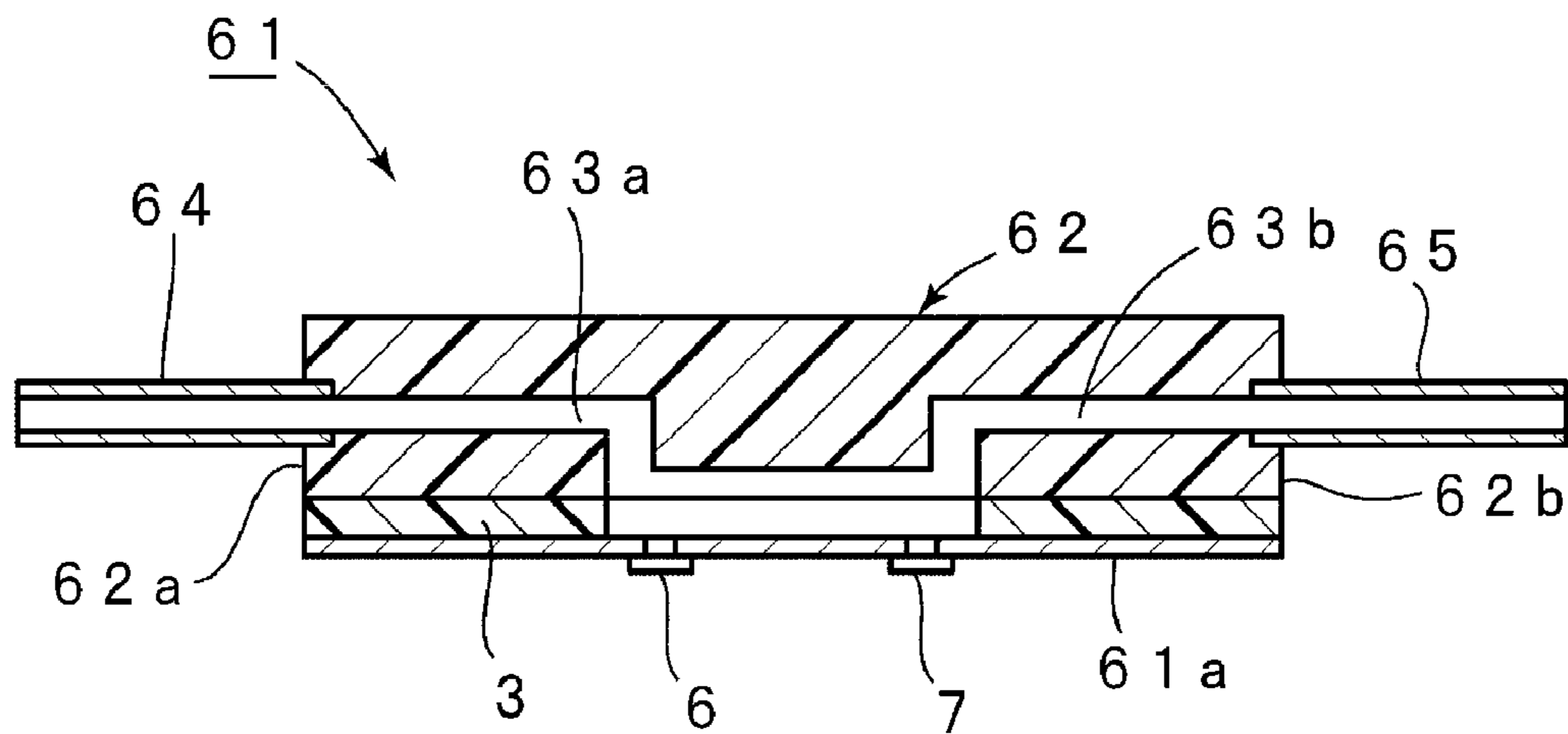
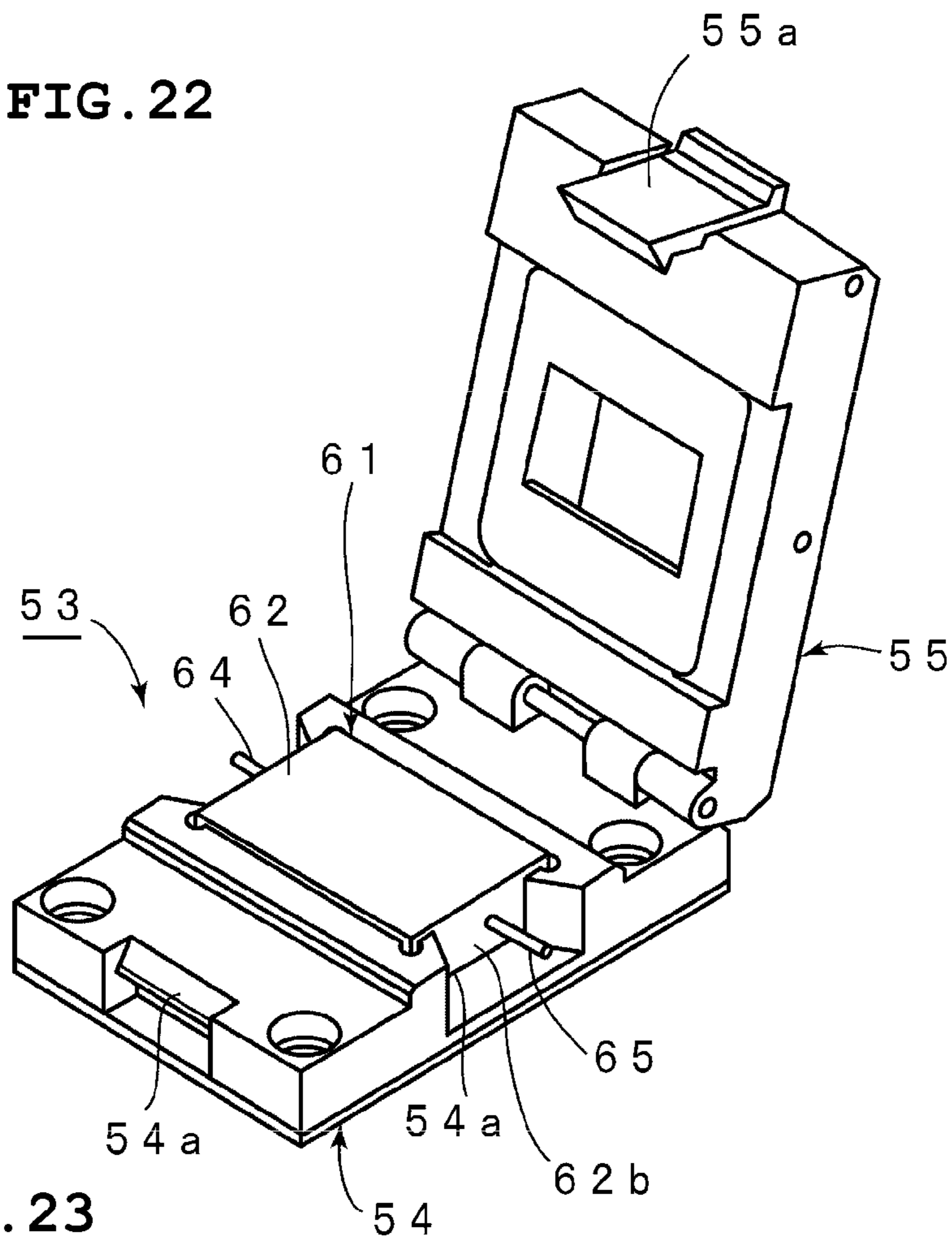

FIG. 21



**FIG. 22**



**FIG. 23**  
**PRIOR ART**

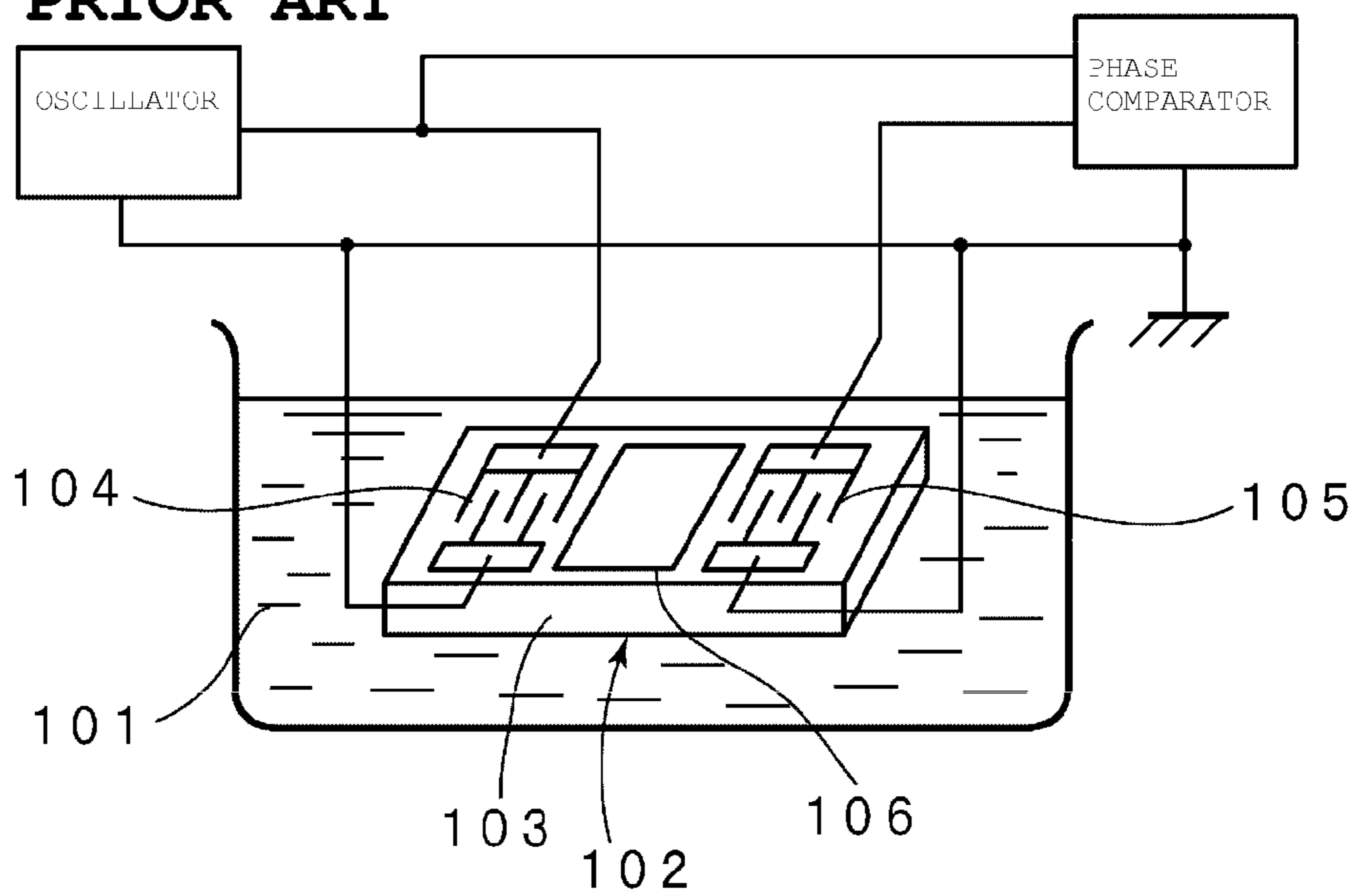

**FIG. 24**

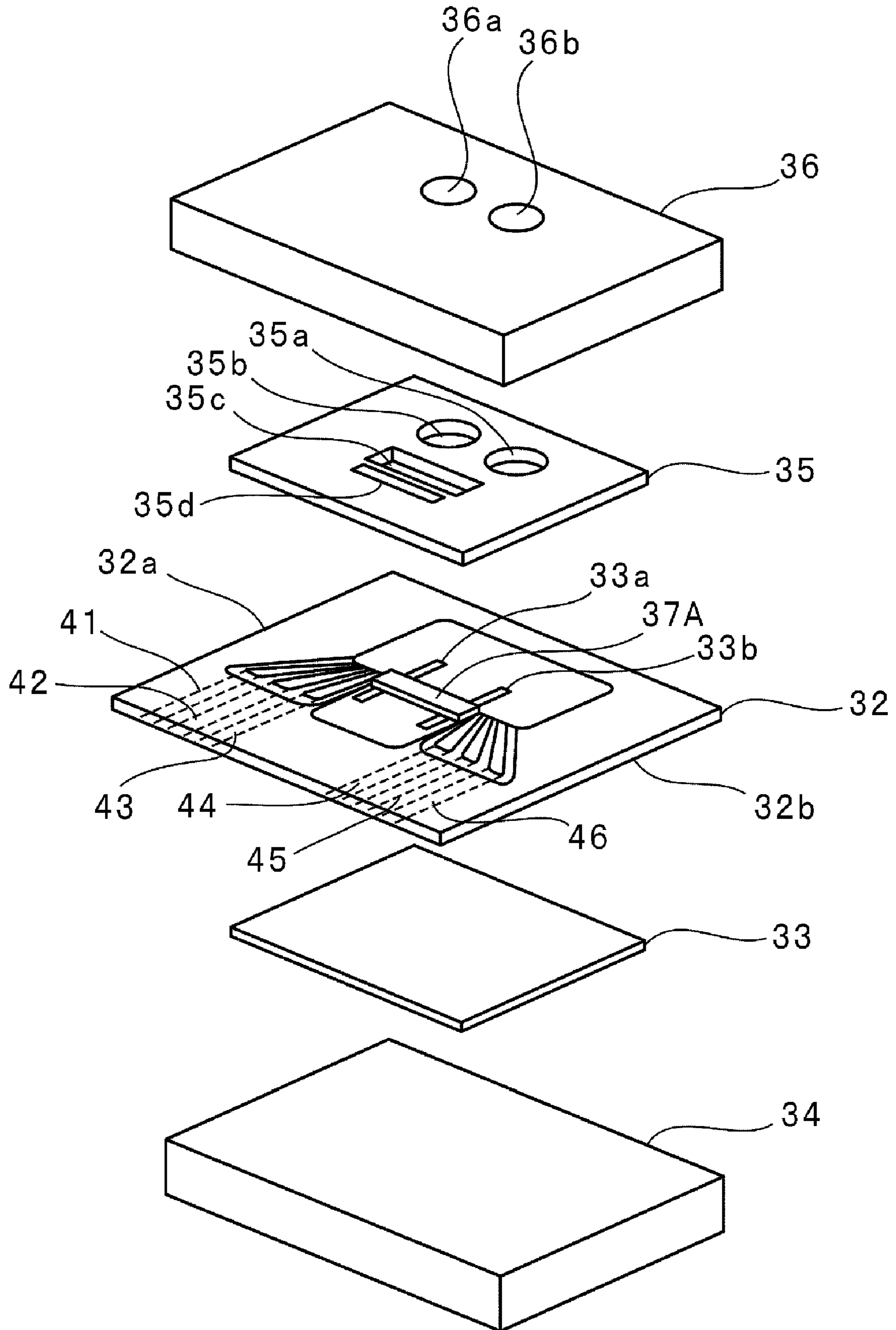
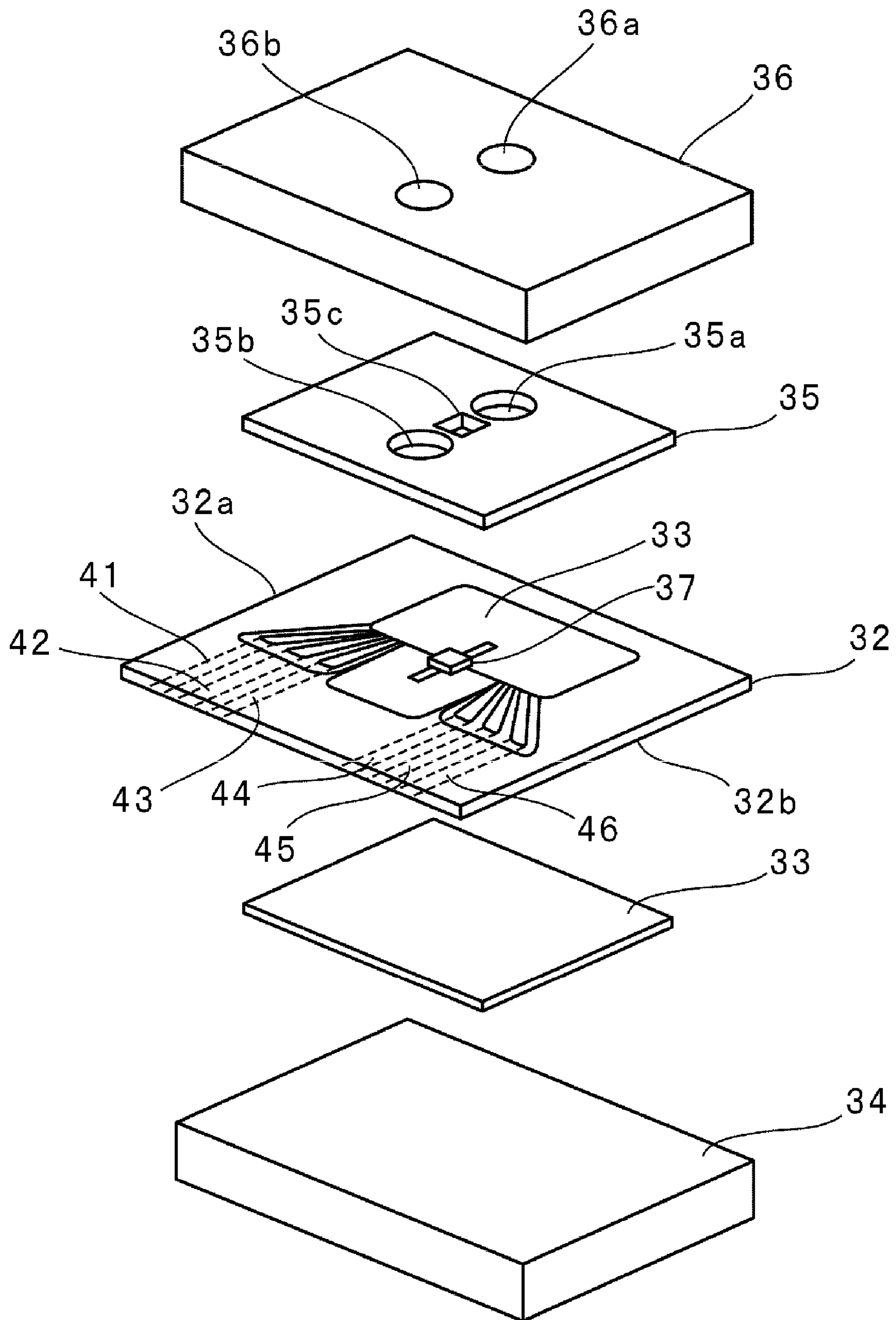

FIG. 25





# SENSOR FOR DETECTING ANALYTE IN LIQUID AND DEVICE FOR DETECTING ANALYTE IN LIQUID USING THE SAME

## BACKGROUND OF THE INVENTION

### 1. Field of the Invention

The present invention relates to sensors for detecting an analyte in liquid using SAW elements (surface acoustic wave elements), and also relates to devices for detecting an analyte in liquid including such sensors. More specifically, the present invention relates to sensors for detecting an analyte in liquid, each sensor includes at least one SAW element mounted on a base substrate via a bump electrode, and also relates to devices for detecting an analyte in liquid with the sensors.

### 2. Description of the Related Art

Various types of sensors for detecting analytes in liquids have been disclosed in the past.

For example, Japanese Unexamined Patent Application Publication No. 63-250560 (Patent Document 1) discloses a sensor for detecting an analyte in liquid using a surface acoustic wave. FIG. 23 is a schematic front cross-sectional view for illustrating the sensor disclosed in Patent Document 1.

A sensor **102** for detecting an analyte in liquid is immersed in a solution **101** containing an analyte. The sensor **102** is defined by a surface acoustic wave element. In other words, the sensor **102** includes a rectangular plate-like piezoelectric substrate **103**, an input IDT electrode **104**, and an output IDT electrode **105**. The input IDT electrode **104** and the output IDT electrode **105** are arranged on the same surface of the piezoelectric substrate **103** with a predetermined distance therebetween. In addition, a membrane **106** for adsorbing an analyte is arranged between the input IDT electrode **104** and the output IDT electrode **105**. A surface acoustic wave is excited in the piezoelectric substrate **103** by applying an alternating voltage to the input IDT electrode **104**. The excited surface acoustic wave propagates toward the output IDT electrode **105**. At the output IDT electrode **105**, an electric signal based on the propagated surface wave is extracted. Since the membrane **106** adsorbs the analyte, the load to the surface of the piezoelectric substrate **103** due to the membrane **106** is changed when the analyte is present. Consequently, the propagating surface acoustic wave is modified by the presence of the analyte and, therefore, the output extracted from the output IDT electrode **105** is changed. Thus, the detection of the analyte and the measurement of concentration thereof are enabled.

However, in the measurement method using the sensor **102** for detecting an analyte in liquid, the sensor **102** must be immersed in a liquid **101**. Therefore, when the amount of the liquid **101** containing the analyte is small, the analyte in the liquid cannot be detected.

Further, even if a large amount of a liquid is prepared, the measurement cost is disadvantageously high when the liquid is expensive.

In addition, in the sensor **102** for detecting an analyte in liquid, a liquid **101** adheres not only to regions where the surface acoustic wave propagates but also to regions where electrode pads or bonding wires, which are connected to the IDT electrodes **103** and **104**, are disposed. Therefore, the electrical characteristic is disadvantageously changed so as to deteriorate the detection accuracy.

On the other hand, Japanese Unexamined Patent Application Publication No. 5-45339 (Patent Document 2) discloses a method for measuring an analyte in liquid without immersing a sensor for detecting an analyte in liquid.

In the sensor of Patent Document 2, an IDT electrode is disposed on a first principle surface of a piezoelectric substrate, and a measuring pond for receiving a liquid containing an analyte is formed on a second principle surface of the piezoelectric substrate, which is the opposite side of the first principle surface. Here, a liquid is injected into the measuring pond provided on the second principle surface, and the measurement is performed. Thus, it is not necessary to immerse the entire sensor in the liquid. Furthermore, since the IDT electrode is not brought into contact with the liquid, the electrical characteristic is not substantially changed.

As described above, in the sensor disclosed in Patent Document 2 for detecting an analyte in liquid, a large amount of liquid is not necessary. In addition, the liquid negligibly adheres to the IDT electrode.

However, in the sensor disclosed in Patent Document 2, a liquid containing an analyte is present on the second principle surface of the piezoelectric substrate. On the other hand, a surface acoustic wave propagates on the first principle surface of the piezoelectric substrate, namely, the surface acoustic wave propagates extremely close to the surface of the principle surface on which the IDT electrode is disposed. Therefore, when a solution is applied to the second principle surface, the surface acoustic wave propagating on the first principle surface is not substantially influenced by the change caused by the presence of the solution. Therefore, in the sensor disclosed in Patent Document 2, the detection accuracy cannot be sufficiently increased.

In addition, in the sensor disclosed in Patent Document 2, energy disperses not only to near the surface of the piezoelectric substrate but also to a certain depth of the piezoelectric substrate. The leak component of a propagating SH wave causes noise, and therefore, the measurement accuracy is disadvantageously decreased.

## SUMMARY OF THE INVENTION

To overcome the problems described above, preferred embodiments of the present invention provide a sensor for detecting an analyte in liquid, which is not required to be immersed in a liquid containing the analyte and which accurately detects the analyte in a small amount of a liquid, and a device for detecting an analyte in liquid with the sensor.

A sensor for detecting an analyte in liquid according to a preferred embodiment of the present invention includes a base substrate, a piezoelectric substrate, and at least one SAW element disposed on the piezoelectric substrate. The base substrate is provided with at least one opening. On one surface of the base substrate, an electrode land is provided at the periphery of the opening. The SAW element includes at least one IDT electrode defining a sensing portion. The at least one SAW element is mounted on the base substrate so that the sensing portion of the at least one SAW element faces the at least one opening provided to the base substrate. In order to mount the SAW element on the base substrate, the sensor also includes a bump electrode connecting the SAW element to the electrode land of the base substrate. The sensor further includes a resin layer coating the circumferences of the SAW element and the bump electrode. Further, the surface of at least one sensing portion is coated with a reaction membrane which binds to an analyte.

In a preferred embodiment of the sensor for detecting an analyte in liquid according to the present invention, the SAW element is defined by a resonator-type SAW filter.

In another preferred embodiment of the sensor for detecting an analyte in liquid according to the present invention, the reaction membrane binds to a specific protein.



In another preferred embodiment of the sensor for detecting an analyte in liquid according to the present invention, the sensor is further provided with a first adhesion layer on a surface of the base substrate, wherein the surface is at the opposite side of the surface on which the SAW element is mounted.

In a further preferred embodiment of the sensor for detecting an analyte in liquid according to the present invention, the sensor is further provided with a first protecting member coating the first adhesion layer.

In another preferred embodiment of the sensor for detecting an analyte in liquid according to the present invention, the sensor is provided with a second protecting member fixed to a surface of the base substrate at the side on which the SAW element is mounted. The second protecting member includes a concave portion for receiving the SAW element.

In a further preferred embodiment of the sensor for detecting an analyte in liquid according to the present invention, the sensor is provided with a second adhesion layer between the base substrate and the second protecting member.

In a further preferred embodiment of the sensor for detecting an analyte in liquid according to the present invention, the first protecting member is provided with a liquid-supplying opening which is connected to the opening of the base substrate.

In another preferred embodiment of the sensor for detecting an analyte in liquid according to the present invention, the sensor is provided with a first channel connecting the liquid-supplying opening and the sensing portion of the SAW element.

In another preferred embodiment of the sensor for detecting an analyte in liquid according to the present invention, the first protecting member is provided with a liquid-discharging opening, and the sensor is further provided with a second channel connecting the liquid-discharging opening and the sensing portion of the SAW element.

A device for detecting an analyte in liquid according to a preferred embodiment of the present invention includes a sensor for detecting an analyte in liquid according to the present invention, an amplifier, a frequency counter, and a controller. The amplifier is connected to the sensor and amplifies output from the sensor.

In an example of the sensor for detecting an analyte in liquid according to a preferred embodiment of the present invention, a plurality of SAW elements are mounted on one side of a base substrate via bump electrodes so that a sensing portion faces an opening of the base substrate. The circumferences of the SAW elements and the bump electrodes are coated with a resin layer, but the resin layer is provided so that the sensing portion is exposed to the opening. Further, the surface of the at least one sensing portion is coated with a reaction membrane.

Therefore, in the measurement, a liquid containing an analyte may be injected into the opening of the base substrate from the side opposite to the side on which the SAW elements are mounted. In other words, it is not necessary to immerse the entire sensor in a large amount of a liquid. Therefore, the analyte in liquid can be detected using a small amount of a liquid.

During detection, a liquid injected into the opening adheres to the sensing portion, which faces the opening, of at least one of the SAW elements. Since the reaction membrane is disposed above the surface of the sensing portion of the at least one SAW element, when the analyte binds to the reaction membrane, the load caused by the reaction membrane is

changed. Therefore, based on the change in the load, the presence of the analyte and the concentration thereof can be measured.

In preferred embodiments of the present invention, the sensing portion of the SAW element is present at the side of the surface on which the surface acoustic wave propagates, and a liquid containing an analyte directly adheres to the reaction membrane which is disposed above the sensing portion. Therefore, the sensitivity of the sensor in measuring the analyte is effectively increased.

Consequently, an analyte in liquid can be measured by using a small amount of a liquid with high accuracy and sufficient sensitivity.

When a resonator-type SAW filter is used as the SAW element, the sensor can be miniaturized as compared to a case in which a transversal filter is used. In addition, the insertion-loss is significantly reduced, which allows a decrease in the amplification degree of an amplifier. Consequently, the electric power consumption is decreased.

When the reaction membrane is one that binds to a specific protein, the existence or nonexistence of the specific protein and the concentration thereof can be detected or measured with high accuracy according to various preferred embodiments of the present invention.

When the sensor is further provided with a first adhesion layer on the base substrate at the side opposite to the surface on which the SAW element is mounted, the circumference of the opening where the sensing surface of the SAW element exposes is coated with the first adhesion layer. Therefore, contamination of the upper surface of the base substrate is prevented. In particular, when an elastic material, such as a rubber sheet, is used as the first adhesion layer, the base substrate and the adhesion layer can be adhered to each other by only pushing the sensor from the base substrate side. Therefore, the leakage of a liquid is securely prevented. In addition, the volume of a trapped liquid can be controlled by controlling the thickness of the first adhesion layer.

Further, when the sensor is provided with a first protecting member coating the first adhesion layer, the volume of an opening provided to the first protecting member and being connected to the opening of the base substrate can be increased by controlling the thickness of the first protecting member. As a result, an increased amount of a liquid can be supplied to the sensing portion.

When the sensor is further provided with a second protecting member having a concave portion for receiving the SAW element and being fixed to the base substrate at the side on which the SAW element is mounted, the second protecting member protects the SAW element mounted on the base substrate.

When the sensor is provided with a second adhesion layer between the base substrate and the second protecting member, the adhesion strength between the second protecting member and the base substrate is effectively increased by the second adhesion layer.

When the first protecting member is provided with a liquid-supplying opening and the liquid-supplying opening is connected to the opening of the base substrate, an increased amount of a liquid can be supplied to the sensing portion of the SAW element.

When the sensor is provided with a first channel connecting the liquid-supplying opening and the sensing portion of the SAW element, the liquid-supplying opening can be arranged at a position which is different from the position of the sensing portion in the surface direction. Thus, flexibility in the



5

design is increased. In addition, a liquid injected into the liquid-supplying opening can be rapidly transferred to the sensing portion.

When the sensor is provided with a liquid-discharging opening to the first protecting member and with a second channel for connecting the sensing portion and the liquid-discharging opening, a liquid used for the measurement of an analyte can be rapidly discharged to the outside from the sensing portion through the liquid-discharging opening.

A device for detecting an analyte in liquid according to preferred embodiments of the present invention includes a sensor for detecting an analyte in liquid according to preferred embodiments of the present invention, an amplifier for amplifying output from the sensor, a frequency counter, and a controller. The sensor outputs a frequency signal based on the presence of an analyte or concentration of an analyte. The frequency signal is amplified by the amplifier and counted by the frequency counter. Thus, since the sensor according to preferred embodiments of the present invention is used in the device, the presence of the analyte and/or the concentration thereof can be determined with high accuracy.

Other features, elements, steps, characteristics and advantages of the present invention will become more apparent from the following detailed description of preferred embodiments of the present invention with reference to the attached drawings.

#### BRIEF DESCRIPTION OF THE DRAWINGS

FIG. 1 is a perspective view showing an appearance of a sensor for detecting an analyte in liquid according to a first preferred embodiment of the present invention.

FIG. 2 is an exploded perspective view of the sensor according to the first preferred embodiment of the present invention.

FIG. 3A is a plan view, FIG. 3B is a lateral cross-sectional view, and FIG. 3C is a front cross-sectional view of the sensor according to the first preferred embodiment of the present invention.

FIG. 4A is a partially cutout enlarged front cross-sectional view showing the details of a mounting structure of a SAW element of the sensor according to the first preferred embodiment, and FIG. 4B is a plan view showing a structure of electrodes defining a sensing portion of the SAW element.

FIG. 5A is a graph showing a measurement result when the sensor for detecting an analyte in liquid according to the first preferred embodiment is used, and FIG. 5B is a graph showing a measurement result when a conventional sensor for detecting an analyte in liquid is used by immersing a surface acoustic wave element in a liquid sample.

FIG. 6 is a block diagram for illustrating an example of a device for detecting an analyte in liquid using the sensor according to the first preferred embodiment of the present invention.

FIG. 7 is a graph for illustrating results obtained by measuring a saline containing bovine serum albumin with the sensor according to the first preferred embodiment of the present invention.

FIG. 8 is a graph showing a variation in minimum insertion-loss before and after the reaction in the measurement results shown in FIG. 7.

FIG. 9 is a graph showing normalized frequencies in the variation of the minimum insertion-loss before and after the reaction in the measurement results shown in FIG. 7.

FIG. 10 is a graph showing a variation in insertion-loss at phase  $0^\circ$  before and after the reaction in the measurement results shown in FIG. 7.

6

FIG. 11 is a graph showing a variation in normalized frequency at phase  $0^\circ$  before and after the reaction in the measurement results shown in FIG. 7.

FIG. 12 is a perspective view showing an appearance of a sensor for detecting an analyte in liquid according to a second preferred embodiment of the present invention.

FIG. 13 is an exploded perspective view of the sensor according to the second preferred embodiment of the present invention.

FIG. 14 is a graph showing a measurement result obtained by using the sensor according to the second preferred embodiment of the present invention.

FIG. 15 is an exploded perspective view of a measurement device utilizing a sensor for detecting an analyte in liquid according to a third preferred embodiment of the present invention.

FIG. 16 is a perspective view showing a state in which a measurement device is provided with a sensor for detecting an analyte in liquid and a holding member.

FIG. 17 is a perspective view of the measurement device shown in FIG. 16 in a state in which a lid is closed.

FIG. 18 is an exploded perspective view of the sensor for detecting an analyte in liquid according to the third preferred embodiment of the present invention.

FIG. 19 is a front cross-sectional view showing a state in which the sensor according to the third preferred embodiment is mounted on a measurement device.

FIG. 20 is a perspective view showing a sensor for detecting an analyte in liquid according to a fourth preferred embodiment of the present invention.

FIG. 21 is a perspective view showing a state in which the sensor according to the fourth preferred embodiment is mounted on a measurement device.

FIG. 22 is a front cross-sectional view of the sensor according to the fourth preferred embodiment of the present invention.

FIG. 23 is a schematic view for illustrating a conventional sensor for detecting an analyte in liquid.

FIG. 24 is an exploded perspective view of a modification example of the sensor according to the second preferred embodiment of the present invention.

FIG. 25 is an exploded perspective view of another modification example of the sensor according to the second preferred embodiment of the present invention.

#### DETAILED DESCRIPTION OF PREFERRED EMBODIMENTS

The present invention will now be clarified by describing preferred embodiments of the present invention with reference to the drawings.

FIG. 1 is a perspective view showing a sensor for detecting an analyte in liquid according to a first preferred embodiment of the present invention. FIG. 2 is an exploded perspective view of the sensor.

As shown in FIG. 2, the sensor 1 for detecting an analyte in liquid according to this preferred embodiment preferably includes a substantially rectangular plate-like base substrate. The base substrate 2 is preferably constructed of a suitable hard material such as a synthetic resin or ceramic. The base substrate 2 is provided with a plurality of openings 2a and 2b. In this preferred embodiment, the openings 2a and 2b are preferably substantially square in plan view. However, the shape is not limited to substantially and may be elliptical, for example, or other suitable shapes.

As shown in FIG. 2, on the top surface of the base substrate 2, a first adhesion layer 3 and a first protecting member 4 are



7

stacked in this order. The first adhesion layer **3** and the first protecting member **4** are provided with substantially rectangular through-holes **3a** and **4a**, respectively. The through-holes **3a** and **4a** are arranged so as to overlap each other in the thickness direction. The opening portion provided by the overlapped through-holes **3a** and **4a** functions as a liquid-supplying opening and also as a liquid-trapping portion for trapping a supplied liquid.

The through-holes **3a** and **4a** are arranged so as to face the openings **2a** and **2b** of the base substrate **2**. The first adhesion layer **3** tightly attaches the first protecting member **4** to the base substrate **2** and may be a rubber adhesive or other adhesive.

The first protecting member **4** is made of a hard material, such as a synthetic resin or ceramic. The through-hole **4a** has a specific volume of space, so that the liquid to be supplied does not leak to the outside from the through-hole **4a** and is securely injected into the openings **2a** and **2b**.

Furthermore, on the bottom surface of the base substrate **2**, a second protecting member **5** is attached preferably via an adhesive. The second protecting member **5** is made of a hard material, such as a synthetic resin or ceramic, and has a plate-like shape. In addition, an adhesive, such as an epoxy adhesive or a rubber adhesive, may be optionally used.

As is shown in FIGS. **1** and **2**, the planar shapes of the first adhesion layer **3**, the first protecting member **4**, and the second protecting member **5** are substantially the same as that of the base substrate **2**. Consequently, the sensor **1** according to this preferred embodiment has an overall substantially rectangular plate-like shape. In addition, the second protecting member **5** is provided with concave portions **5a** and **5b** at regions corresponding to positions under the openings **2a** and **2b**. The concave portions **5a** and **5b** function as receiving portions by surrounding SAW elements described below. The concave portions **5a** and **5b** may have bottoms or may be through-holes. In order to protect the SAW elements, the depth of each of the concave portions **5a** and **5b** is greater than the thickness of the SAW elements.

Furthermore, the second protecting member **5** is provided with a pair of through-holes **5c** and **5d** near one short side and a pair of through-holes **5e** and **5f** near the other short side. The through-holes **5c** to **5f** are provided for inserting measurement pins therein when properties are measured.

In addition, it is not necessary that all of the base substrate **2**, the adhesion layer **3**, the protecting member **4**, and the second protecting member **5** shown in FIG. **2** have the same planar dimension. For example, the base substrate **2** which is made of a relatively expensive material may have a small size, and other members which are made of inexpensive materials may have sizes suitable for handling. With that, a sensor for detecting an analyte in liquid, which is inexpensive and superior in handling, can be advantageously provided.

FIGS. **3A** to **3C** are a plan view, a lateral cross-sectional view, and a front cross-sectional view of the sensor **1**. As shown in FIGS. **3B** and **3C**, first and second SAW elements **6** and **7** are mounted on the bottom surface of the base substrate **2**, as a plurality of SAW elements. In FIG. **3A**, the SAW elements **6** and **7** are schematically indicated by the x marks.

In FIGS. **3B** and **3C**, the mounting structure of the SAW elements **6** and **7** on the bottom surface of the base substrate **2** is illustrated in a simplified manner to facilitate understanding. As a representative of the SAW elements, the mounting structure of the SAW element **6** is shown in detail in FIG. **4A** as a partially cutout enlarged front view of the SAW element **6**.

The SAW element **6** includes a piezoelectric substrate **8**. The piezoelectric substrate **8** is preferably made of a piezo-

8

electric single crystal or piezoelectric ceramic. On the top surface of the piezoelectric substrate **8**, IDT electrodes **9** and **10** are provided. Further, reflectors are provided at both sides of the IDT electrodes **9** and **10** in the propagation direction of surface waves. In FIG. **4A**, the region in which the IDT electrodes **9** and **10** are disposed is schematically illustrated. More specifically, as shown in FIG. **4B** as a schematic plan view of the electrode structure, the IDT electrode **9** and the IDT electrode **10** are arranged in parallel in the propagation direction of surface waves. Furthermore, reflectors **11** and **12** are provided at both sides of the region where the IDT electrodes **9** and **10** are disposed. Thus, a resonator filter is provided.

In FIG. **4A** described above, the region in which the IDT electrodes **9** and **10** are disposed defines as a sensing portion, and these IDT electrodes **9** and **10** are coated with a reaction membrane **13**. The reaction membrane **13** includes a material which binds to an analyte in liquid. The reaction membrane **13** may be made of any material as long as the analyte can bind to the material on the surface of the reaction membrane **13**. For example, the reaction membrane **13** includes a material which binds to a specific protein in a liquid. In such a case, the presence of the specific protein and concentration thereof can be detected or measured using the sensor **1** for detecting an analyte in liquid.

An example of the specific protein is bovine serum albumin, and an example of the reaction membrane **13** in such a case is N-2(aminoethyl)-3-aminopropyltrimethoxysilane  $[(\text{CH}_3\text{O})_3\text{SiC}_3\text{H}_6\text{NHC}_2\text{H}_4\text{NH}_2]$ .

The reaction membrane **13** may include a material which binds to an analyte other than proteins. Furthermore, the reaction membrane **13** may include only a material which binds to an analyte or may include a composition of a material which binds to an analyte and another base material which functions as a matrix.

As shown in FIG. **4A**, the SAW element **6** includes the IDT electrodes **9** and **10** on the top surface of the piezoelectric substrate **8**. Therefore, a sensing portion is provided on the top surface of the piezoelectric substrate **8**. In this preferred embodiment, the SAW element **6** is mounted on the bottom surface of the base substrate **2** so that the sensing portion faces the opening **2a**.

Furthermore, as shown in FIG. **4A**, the SAW element **6** is connected to electrode lands **14** and **15** disposed on the bottom surface of the base substrate **2** via bump electrodes **16a** and **16b**. The bump electrodes **16a** and **16b** electrically connect the IDT electrodes **9** and **10** of the SAW element **6** to the electrode lands **14** and **15** and fix the SAW element **6** to the bottom surface of the base substrate **2**.

In other words, the SAW element **6** is mounted on the bottom surface of the base substrate **2** by a flip-chip bonding method using the bump electrodes **16a** and **16b**. Therefore, in this preferred embodiment, the mounting structure of the SAW elements **6** and **7** on the base substrate **2** can be miniaturized as compared to that using a wire bonding method.

As the bump electrodes **16a** and **16b**, bump electrodes made of a metal, such as Au, may be optionally used.

The SAW element **7** is also mounted on the bottom surface of the base substrate **2** as in the SAW element **6**. In addition, a resin layer **17** is provided for sealing the connection parts of the bump electrodes **16a** and **16b**. The resin layer **17** is hardened preferably using a thermosetting resin or a photosetting resin. Examples of the thermosetting or photosetting resin include epoxy resins and polyimide resins.

As shown in FIG. **2** and FIG. **3A**, the electrode lands electrically connected to the SAW elements **6** and **7** are connected to wiring electrodes **18**, **19**, **20**, and **21** disposed on the



bottom surface of the base substrate **2**. The wiring electrodes **18** and **19** are connected to the electrode lands **14** and **15** which are connected to the SAW element **6**. The outside ends of the wiring electrodes **18** and **19** are connected to electrode pads **18a** and **19a**. As shown in FIG. 2, the electrode pads **18a** and **19a** are arranged at positions so as to overlap the through-holes **5c** and **5d** provided to the second protecting member **5**. When measurement pins are inserted into the through-holes **5c** and **5d**, the measurement pins abut against the electrode pads **18a** and **19a** to allow the measurement.

Similarly, electrode pads **20a** and **21a** are provided at the outside ends of the wiring electrodes **20** and **21**. The electrode pads **20a** and **21a** are located inside the through-holes **5e** and **5f** provided in the second protecting member **5**.

The detection procedure using the sensor **1** for detecting an analyte in liquid according to this preferred embodiment will be described.

In a detection of an analyte in liquid, a liquid containing an analyte is supplied to the through-hole **4a** of the first protecting member **4** as a liquid-supplying opening. The liquid may be supplied to the through-hole **4a** by injecting or dropping the liquid with a syringe or pipette. As a result, the liquid is fed into the openings **2a** and **2b** through the through-holes **4a** and **3a**. Then, the liquid adheres to the sensing portions of the SAW elements **6** and **7** facing the openings **2a** and **2b**. When the sensing portion of the SAW element **6** is provided with a reaction membrane **13** and the liquid contains an analyte, the analyte binds to the reaction membrane **13** to induce a change. This change modifies the load applied to the sensing portion of the SAW element **6**. Therefore, a difference in the load occurs between the load applied to a SAW element which is provided with the reaction membrane **13** and that applied to a SAW element which is not provided with the reaction membrane **13** as a standard. Consequently, the outputs of the SAW elements **6** and **7** are different from each other to allow the detection of the presence of the analyte and measurement of the concentration thereof.

The device for detecting an analyte using the sensor **1** according to this preferred embodiment is not specifically limited. For example, as shown in FIG. 6, an amplifier **22** is connected to the output terminal of the sensor **1**. The output of the amplifier **22** is connected to the input side of the sensor **1**, and the output terminal of the amplifier **22** is connected to a frequency counter **23**. The output terminal of the frequency counter **23** is connected to a controller **24**. The controller **24** determines the presence or absence of a measurement result based on a signal from the frequency counter **23**.

FIG. 5A is a graph showing output signals as a measurement result when saline containing bovine serum albumin is used as the liquid to be measured and the reaction membrane **13** includes a material which binds to the bovine serum albumin.

As shown in FIG. 5A, it is confirmed that the oscillation amplitude at the normalized oscillation frequency (frequency/resonance frequency of SAW element) is significantly large due to the presence of bovine serum albumin, and thereby the presence of bovine serum albumin can be detected with high accuracy.

In addition, a sensor for detecting an analyte in liquid, which includes a SAW element similar to the SAW element **6**, is provided and immersed in saline containing bovine serum albumin as described above. FIG. 5B shows output signals when the measurement of a SAW element is performed in a state in which portions other than the sensing portion of the SAW element (portions other than the IDT, namely, wiring patterns, electrode pads, and so on) are exposed to the saline.

As shown in FIG. 5B, it is confirmed that bovine serum albumin is not detected because the measurement sensitivity is insufficient.

FIG. 7 is a graph showing the measurement results when saline containing bovine serum albumin is measured using the sensor **1** according to the above-described preferred embodiment. The solid line in FIG. 7 shows before the reaction, namely, the result when saline not containing bovine serum albumin is supplied. The broken line shows the result when saline containing about 50  $\mu\text{g/ml}$  of bovine serum albumin is measured. FIG. 7 shows the insertion-loss/frequency characteristic and phase/frequency characteristic. When saline containing bovine serum albumin is supplied, the characteristics of the SAW elements **6** and **7** are significantly changed. Here, the average characteristic between the SAW elements **6** and **7** is shown.

In order to easily make comparison, the results shown in FIG. 7 are divided into the measurement results before the reaction and after the reaction and are shown in FIGS. 8 to 11. FIG. 8 shows the minimum insertion-loss. FIG. 9 shows the normalized frequency when the minimum insertion-loss largely changes. FIG. 10 shows the insertion loss at phase  $0^\circ$ . FIG. 11 shows the normalized frequency at phase  $0^\circ$ .

As shown in FIGS. 8 to 11, it is recognized that the minimum insertion-loss, normalized frequency when the minimum insertion-loss largely changes, insertion-loss at phase  $0^\circ$ , and normalized frequency at phase  $0^\circ$  are substantially changed between before and after the reaction. Therefore, it is confirmed that the presence of bovine serum albumin can be detected with high accuracy by detecting those changes.

FIG. 12 is a perspective view showing an appearance of a sensor for detecting an analyte in liquid according to a second preferred embodiment of the present invention. FIG. 13 is an exploded perspective view of the sensor.

In the sensor **31** for detecting an analyte in liquid according to the second preferred embodiment, a first adhesion layer **33** and a first protecting member **34** are stacked on the bottom surface of a base plate **32**. Furthermore, on the top surface of the base plate **32**, a second adhesion layer **35** and a second protecting member **36** are stacked in this order. In this preferred embodiment, SAW elements **37** and **38** are mounted on the top surface of the base plate **32** by a flip-chip bonding method. In other words, on the bottom surface (not shown in FIG. 13) of the base plate **32**, IDT electrodes, reflectors, and a reaction membrane are arranged. In addition, the base plate **32** is provided with openings facing a sensing portion as in the first preferred embodiment, namely, sensing portions of the SAW elements **37** and **38** are arranged so as to face the openings.

In other words, the structure of the SAW elements **37** and **38** and the base plate **32** corresponds to a structure obtained by turning the base substrate **2** and the SAW elements **6** and **7** in the first preferred embodiment.

The lengths of the opposing sides **32a** and **32b** of the base plate **32** are greater than those of the first protecting member **34** and the second protecting member **36** in the same direction. Furthermore, on the bottom surface of the base plate **32**, wiring electrodes **41** to **46** defining connecting electrodes to the outside are disposed. The wiring electrodes **41** to **46** are configured so as to extend to an end **32c** of the base plate **32**. As shown in FIG. 12, the end **32c** of the base plate **32** protrudes further than the ends of the first protecting member **34** and the second protecting member **36**. Therefore, in the sensor **31** according to this preferred embodiment, for example, the protruding portion **32d** is inserted into a card insertion slot of a measurement device and thereby the wiring electrodes **41**



to 46 are electrically connected to electrodes of the measurement device to enable the measurement.

As shown in FIG. 13 described above, the first protecting member 34 stacked on the first adhesion layer 33. In addition, the second protecting member 36 is disposed on the second adhesion layer 35. The second protecting member 36 is provided with through-holes 36a and 36b. The through-hole 36a functions as a liquid-supplying hole and the through-hole 36b functions as a liquid-discharging hole. The adhesion layer 35 is provided with through-holes 35a and 35b so that the through-holes 35a and 35b overlap the through-holes 36a and 36b, respectively. In addition, the adhesion layer 35 is provided with through-holes 35c and 35d so that the SAW elements 37 and 38 are surrounded by the through-holes 35c and 35d, respectively. Although not shown in the figure, concave portions for receiving the SAW elements 37 and 38 may be similarly provided on the bottom surface of the second protecting member 36.

Furthermore, the adhesion layer 35 is provided with a through-hole 35e extending substantially parallel to the direction connecting between the SAW elements 37 and 38.

The base plate 32 is provided with first channels 33a and 33b which face the through-hole 35e. The first channels 33a and 33b are formed by forming groove-like through-holes in the base substrate. One end of each of the first channels 33a and 33b is connected to the through-hole 35e. The other ends of the first channels 33a and 33b are connected to the through-hole 35a or 35b and the through-hole 36a or 36b, which are located above. Therefore, a liquid supplied to the through-hole 36a defining the liquid-supplying opening reaches the first channel 33a through the through-hole 35a. In addition, when the liquid flows in the first channel 33a, the liquid enters the bottom surface of the SAW element 37 from the opening located on the bottom surface of the SAW element 37 and is brought into contact with the sensing portion of the SAW element 37. Further, the liquid reaches the second channel 33b from the first channel 33a through the through-hole 35e defining a second channel. Then, the liquid is brought into contact with the sensing portion of the SAW element 38 exposing the liquid to an opening provided to the base substrate 32 at the second channel 33b and further flows to the through-hole 36b defining a liquid-discharging hole from the end of the channel 33b.

In order to achieve the above-described flow of a liquid, for example, the liquid is supplied to the through-hole 36a and discharged from the through-hole 36b by pressing the tip of a tube or pipette to the through-hole 36a and supplying a liquid into the through-hole 36a while applying a pressure to the liquid or by aspirating the liquid from the through-hole 36b.

In the sensor 31 for detecting an analyte in liquid according to this preferred embodiment, an analyte in liquid can also be measured by supplying a small amount of the liquid as in the first preferred embodiment. In addition, in this preferred embodiment, the end 32c of the base substrate 32 protrudes further than other members. Therefore, the measurement can be readily performed by inserting the protruding portion into a card insertion slot of a card-type measurement device.

FIG. 14 is a graph showing measurement results when the sensor for detecting an analyte in liquid according to the second preferred embodiment is used. In FIG. 14, the solid line shows the result obtained by measuring saline containing about 134  $\mu\text{g/ml}$  of bovine serum albumin. The broken line shows the result obtained by measuring saline containing about 3  $\mu\text{g/ml}$  of bovine serum albumin. As shown in FIG. 14, it is confirmed that the change in concentration of bovine serum albumin is extremely accurately detected based on a variation in the normalized frequency.

In the second preferred embodiment, two SAW elements 37 and 38 are used. However, as a modified example shown in FIG. 24, the SAW element may be a single SAW element 37A. In such a case, the SAW element 37A is provided with two IDTs as two sensing portions.

Furthermore, although two IDTs are provided as the sensing portions in the modified example shown in FIG. 24, the SAW may be a single SAW element 37 provided with only one IDT as the sensing portion as in a modified example shown in FIG. 25.

When a single element for sensing is used as in modified examples shown in FIGS. 24 and 25, the cost and size of the sensor can be decreased.

A sensor for detecting an analyte in liquid according to a third preferred embodiment will be described with reference to FIGS. 15 to 19. In this preferred embodiment, a sensor 51 for detecting an analyte in liquid is mounted on a measurement device 53 with a holding plate 52, which is separately shown in the upper side of the sensor 51 in the figure.

FIG. 18 is an exploded perspective view for illustrating the sensor 51. The sensor 51 is provided with a base substrate 51a on which an adhesion layer 3 is fixed. On the rear surface of the base substrate 51a, SAW elements are mounted as in the sensor 1 in the first preferred embodiment.

The sensor 51 according to this preferred embodiment is configured as in the sensor 1 according to the first preferred embodiment except that the first protecting member 4 is not provided. Therefore, in the sensor 51, the first adhesion layer 3 is exposed to the upper surface. Since the sensor 51 is configured as in the sensor 1, the description for the first preferred embodiment is referred to here.

As shown in FIG. 15 described above, in this preferred embodiment, the measurement device 53 includes a base body 54 for mounting the sensor 51 thereon and a lid 55 which is attached to a connection part at one end of the base body 54 so as to be rotatable around the connection part as the center. Furthermore, the base body 54 is provided with a sensor-mounting portion 54a for mounting the sensor 51 thereon. The sensor-mounting portion 54a is provided with measurement probe pins 56a and 56b. The sensor 51 is mounted on the sensor-mounting portion 54a from above the measurement probe pins 56a and 56b.

In addition, above the sensor 51, a holding plate 52 is disposed. The holding plate 52 is similar to the first protecting member 4 provided to the sensor 1 according to the first preferred embodiment.

As shown in FIG. 16, the sensor 51 and the holding plate 52 are mounted on the device and then the lid 55 is rotated with the connection part so that a notch 55a provided at the end of the lid 55 is engaged with a protrusion 54b provided to one end of the base body 54. Thus, as shown in FIG. 17, the notch 55a of the lid 55 is engaged with the protrusion 54b to close the lid 55. As shown in FIG. 19, in the state in which the lid 55 is closed, the holding plate 52 is pressed onto the first adhesion layer 3. The thickness of the holding plate 52 is determined so that the holding plate 52 is pressed downward by the bottom surface of the lid 55. Therefore, the measurement probe pins 56a and 56b are securely abutted against the electrodes disposed on the bottom surface of the sensor 51 to allow the measurement.

As is obvious from this preferred embodiment, the sensor for detecting an analyte in liquid according to the present invention may not be provided with the first protecting member. In other words, a holding plate 52 may be used instead of the first protecting member. In addition, in some cases, the sensor may not be provided with the holding plate 52 when the thickness of the adhesion layer 3 is sufficiently increased.



The holding plate **52** may be optionally made of a rigid material, such as a metal, synthetic resin, or ceramic. In addition, the holding plate **52** may be made of an elastic material, such as rubber.

Furthermore, in cases in which the holding plate **52** is used or not, the first adhesion layer **3** is preferably made of an elastic material, such as a rubber sheet. With such a material, the first adhesion layer **3** is securely adhered to the upper and lower members by pressing from above. Thus, leakage of a liquid is prevented.

In addition, by controlling the thickness of the adhesion layer **3**, the volume for trapping a liquid can be readily adjusted to a desired value.

In addition, the material for the adhesion layer **3** is not limited to elastic materials, such as rubber. An adhesive tape which is made of an adhesive agent provided on one surface of the backing material which is made of a synthetic resin film, such as polyethylene terephthalate, may be used as the adhesion layer **3**.

When the sensor is not provided with the first protecting member, the number of components of the sensor itself is reduced. Therefore, the cost of the sensor for detecting an analyte in liquid is reduced. In addition, the holding plate **52** is not directly exposed to a liquid, and therefore, can be used repeatedly.

In FIG. **15**, the holding plate **52** is prepared as a different member from the lid **55**. However, the holding plate **52** may be fixed to the bottom surface of the lid **55** in advance. Furthermore, the bottom surface of the lid **55** may be integrally provided with a portion having the same function as that of the holding plate **52**. In such cases, the number of the components is further reduced.

However, the holding plate **52** is preferably provided as a different member because the structure of the lid **55** can be simplified and the thickness of the holding plate **52** can be readily modified. Consequently, one measurement device **53** can be used for various types of sensors.

FIGS. **20** to **22** are views for illustrating a sensor for detecting an analyte in liquid according to a fourth preferred embodiment. As shown in FIGS. **20** and **21**, in this preferred embodiment, the sensor **61** for detecting an analyte in liquid includes a base substrate **61a**, an adhesion layer **3** disposed on the base substrate **61a**, and a holding plate **62** disposed on the adhesion layer **3**. The adhesion layer **3** may be similar to the adhesion layer **3** in the first preferred embodiment. In addition, on the bottom surface of the base substrate **61a**, SAW elements **6** and **7** are disposed. The structure at a portion where the base substrate **61a** and the SAW elements **6** and **7** are disposed is substantially the same as that of the sensor **1** in the first preferred embodiment. Therefore, the description of the first preferred embodiment is referred to here.

In addition, the holding plate **62** is disposed on the adhesion layer **3**. The holding plate **62** may be optionally formed of a material, such as a metal, synthetic resin, or ceramic. The sensor according to this preferred embodiment is provided with channels **63a** and **63b** in which a liquid as a measuring object flows. The inner ends of the channels **63a** and **63b** extend to a detection portion. The outer ends of the channels **63a** and **63b** extend to opposing end faces **62a** and **62b** of the holding plate **62**. Tubes **64** and **65** are fixed to the end faces **62a** and **62b**. The tubes **64** and **65** are connected to the channels **63a** and **63b**. In this preferred embodiment, a liquid as a measuring object is supplied and discharged through the tubes **64** and **65**. Therefore, the leakage of the liquid from the top surface of the holding plate **62** is prevented.

The sensor **61** according to this preferred embodiment can be used, as shown FIG. **22**, by placing the sensor **61** on the

sensor-mounting portion **54a** of the measurement device **55** and then closing the lid **55**. In this case also, electrodes disposed on the bottom surface of the sensor **61** can be securely abutted against the measurement probe pins **56a** and **56b** (refer to FIG. **15**) by adding flexibility to the adhesion layer **3** or by adding flexibility to a portion of the holding plate **62**.

Furthermore, in this preferred embodiment, two SAW elements are used, and one of the two SAW elements is provided with a reaction membrane. However, in the present invention, the number of the SAW elements may be one element or three or more elements.

For example, when first to third SAW elements, are used, the SAW elements are configured as follows: Among the first to third SAW elements, the first and second SAW elements are each provided with a reaction membrane and the third SAW element is not provided with a reaction membrane. In this case, the third SAW element functions as a reference. A liquid is supplied to the exposed first to third SAW elements and then frequencies are measured. A first frequency variation which is the difference between frequencies in the first SAW element and the third SAW element and a second frequency variation which is the difference between frequencies in the second SAW element and the third SAW element are determined. Then, the average of the first and second frequency variations is calculated. Using the average, the measurement accuracy in analyte measurement based on the frequency variation is increased.

In addition, in the sensor for detecting an analyte in liquid according to the second preferred embodiment shown in FIG. **13**, the size of the opening of the base substrate **32** is larger than that of the SAW elements **37** and **38**. However, in the sensor **51** shown in FIG. **18**, the size of the opening of the base substrate **51a** is smaller than that of the SAW elements **37** and **38**. Thus, either the size of the SAW element or the size of the opening can be larger than the other.

While preferred embodiments of the present invention have been described above, it is to be understood that variations and modifications will be apparent to those skilled in the art without departing the scope and spirit of the present invention. The scope of the present invention, therefore, is to be determined solely by the following claims.

What is claimed is:

1. A sensor for detecting an analyte in liquid, the sensor comprising:
  - a base substrate provided with at least one opening and an electrode land on a surface thereof at a periphery of the opening;
  - a piezoelectric substrate, at least one SAW element including at least one IDT electrode and defining a sensing portion provided on the piezoelectric substrate, the piezoelectric substrate mounted on the base substrate so that the sensing portion of the at least one SAW element faces the at least one opening of the base substrate;
  - a bump electrode connecting the at least one SAW element to the electrode land of the base substrate and mounting the at least one SAW element on the base substrate;
  - a resin layer coating circumferences of the at least one SAW element and the bump electrode; and
  - a reaction membrane selected to bind to an analyte and coating the surface of at least one sensing portion.
2. The sensor for detecting an analyte in liquid according to claim 1, wherein the at least one SAW element is a resonator SAW filter.
3. The sensor for detecting an analyte in liquid according to claim 1, wherein the reaction membrane binds to a specific protein.



## 15

4. The sensor for detecting an analyte in liquid according to claim 1, further comprising a first adhesion layer on a surface of the base substrate, the surface being at an opposite side of the surface on which the at least one SAW element is mounted.

5. The sensor for detecting an analyte in liquid according to claim 4, further comprising a first protecting member coating the first adhesion layer.

6. The sensor for detecting an analyte in liquid according to claim 1, further comprising a second protecting member fixed to the base substrate at the side on which the at least one SAW element is mounted, the second protecting member being provided with a concave portion for receiving the at least one SAW element.

7. The sensor for detecting an analyte in liquid according to claim 6, further comprising a second adhesion layer between the base substrate and the second protecting member.

8. The sensor for detecting an analyte in liquid according to claim 5, wherein the first protecting member is provided with a liquid-supplying opening, the liquid-supplying opening being connected to the opening of the base substrate.

## 16

9. The sensor for detecting an analyte in liquid according to claim 8, further comprising a first channel arranged to connect the liquid-supplying opening to the sensing portion of the at least one SAW element.

5 10. The sensor for detecting an analyte in liquid according to claim 9, wherein the first protecting member is provided with a liquid-discharging opening, and the sensor further comprises a second channel arranged to connect the liquid-discharging opening to the sensing portion of the SAW element.

11. A device for detecting an analyte in liquid, the device comprising:

a sensor for detecting an analyte in liquid according to claim 1;

an amplifier connected to the sensor and arranged to amplify output from the sensor;

a frequency counter; and

a controller.

\* \* \* \* \*