



US007386424B2

(12) **United States Patent**  
**DeBoer et al.**

(10) **Patent No.:** **US 7,386,424 B2**  
(45) **Date of Patent:** **Jun. 10, 2008**

(54) **ASTRONOMICAL CALCULATIONS IN LIGHTING CONTROL PANEL WITH PRE-POPULATED CITIES**

5,936,362 A \* 8/1999 Alt et al. .... 315/312  
6,940,735 B2 \* 9/2005 Deng et al. .... 363/37  
6,965,801 B2 \* 11/2005 Hall ..... 700/66

(75) Inventors: **John DeBoer**, Decatur, GA (US);  
**Seshagiri R Marellapudi**, Norcross, GA (US); **Ravikumar Balasubramaniam**, Alpharetta, GA (US); **David M Williams**, Alpharetta, GA (US)

**OTHER PUBLICATIONS**

Bupasiri et al., 'Optimal Electric Power Distribution System Reliability Indices Using Binary Programming', 2003, IEEE Publication, pp. 556-561.\*

(73) Assignee: **Siemens Energy & Automation, Inc.**, Alpharetta, GA (US)

\* cited by examiner

(\*) Notice: Subject to any disclaimer, the term of this patent is extended or adjusted under 35 U.S.C. 154(b) by 0 days.

*Primary Examiner*—Edward Raymond  
*Assistant Examiner*—Elias Desta

(21) Appl. No.: **11/635,232**

(57) **ABSTRACT**

(22) Filed: **Dec. 7, 2006**

An electrical distribution system for selectively connecting an electrical power source to a load device uses astronomical calculations. The system comprises a switching device electrically connected between an electrical power source and a load device for selectively delivering electrical power to the load device. A control system controls operation of the switching device. The control system comprises a programmed controller for commanding operation of the switching device in accordance with a scheduling routine stored in a memory. The scheduling routine enables control of the switching device based on sunrise and sunset time. The memory further comprises a database of a plurality of geographic locations and coordinate information for the plurality of geographic locations. The control system further comprises a setup routine comprising a user interface enabling a user to select one of the plurality of geographic locations and a manager routine automatically determining sunrise and sunset times using the coordinate information for the selected geographic location and providing the sunrise and sunset times to the scheduling routine.

(65) **Prior Publication Data**

US 2008/0077360 A1 Mar. 27, 2008

**Related U.S. Application Data**

(60) Provisional application No. 60/826,584, filed on Sep. 22, 2006.

(51) **Int. Cl.**  
**G06F 11/00** (2006.01)

(52) **U.S. Cl.** ..... **702/188**; 702/182

(58) **Field of Classification Search** ..... 702/182,  
702/188; 700/22, 31, 19, 286–298; 307/29,  
307/37, 38; 705/412, 63; 315/312, 159;  
340/825.36

See application file for complete search history.

(56) **References Cited**

**U.S. PATENT DOCUMENTS**

4,362,970 A \* 12/1982 Grady ..... 315/159

**20 Claims, 7 Drawing Sheets**

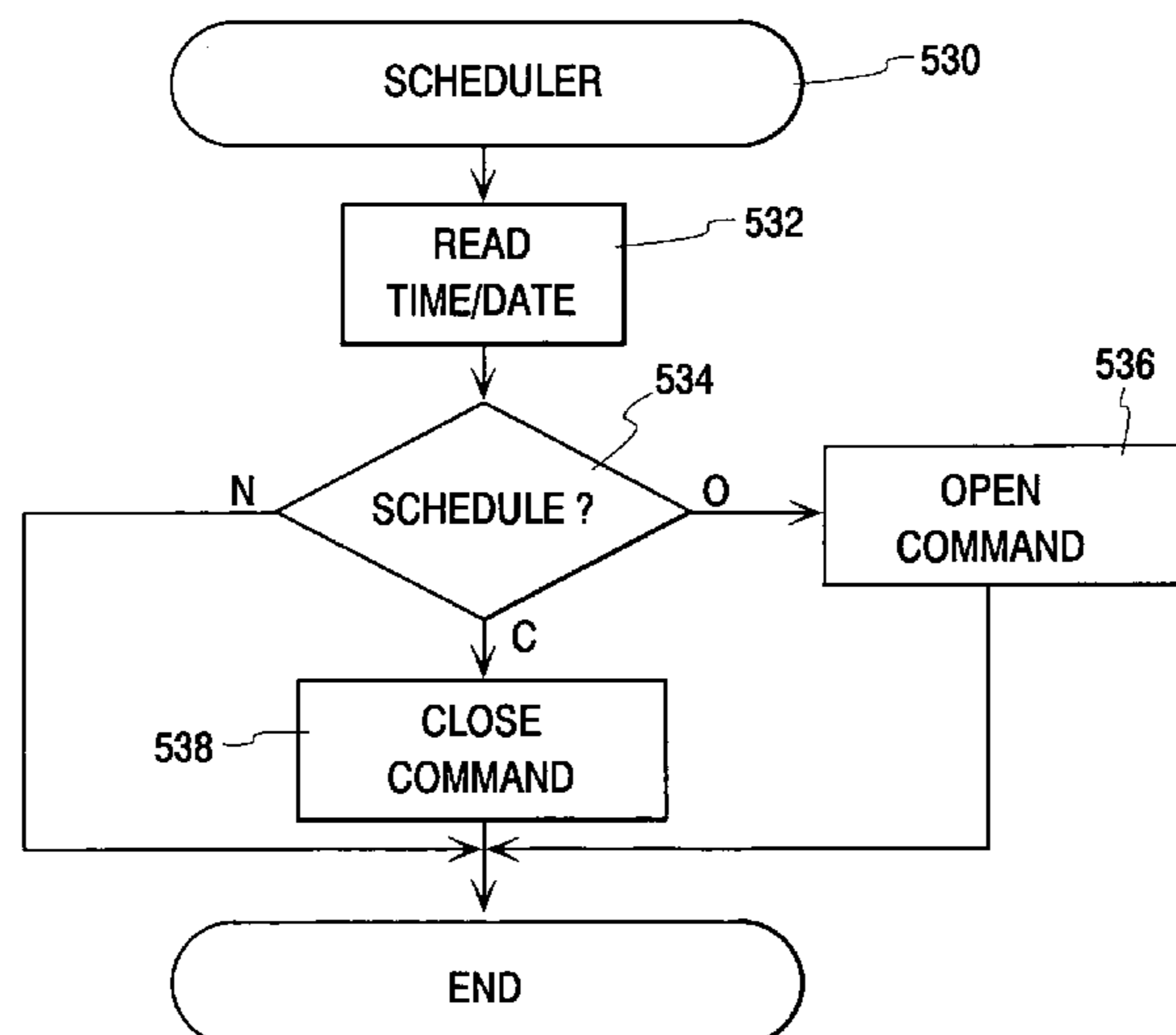

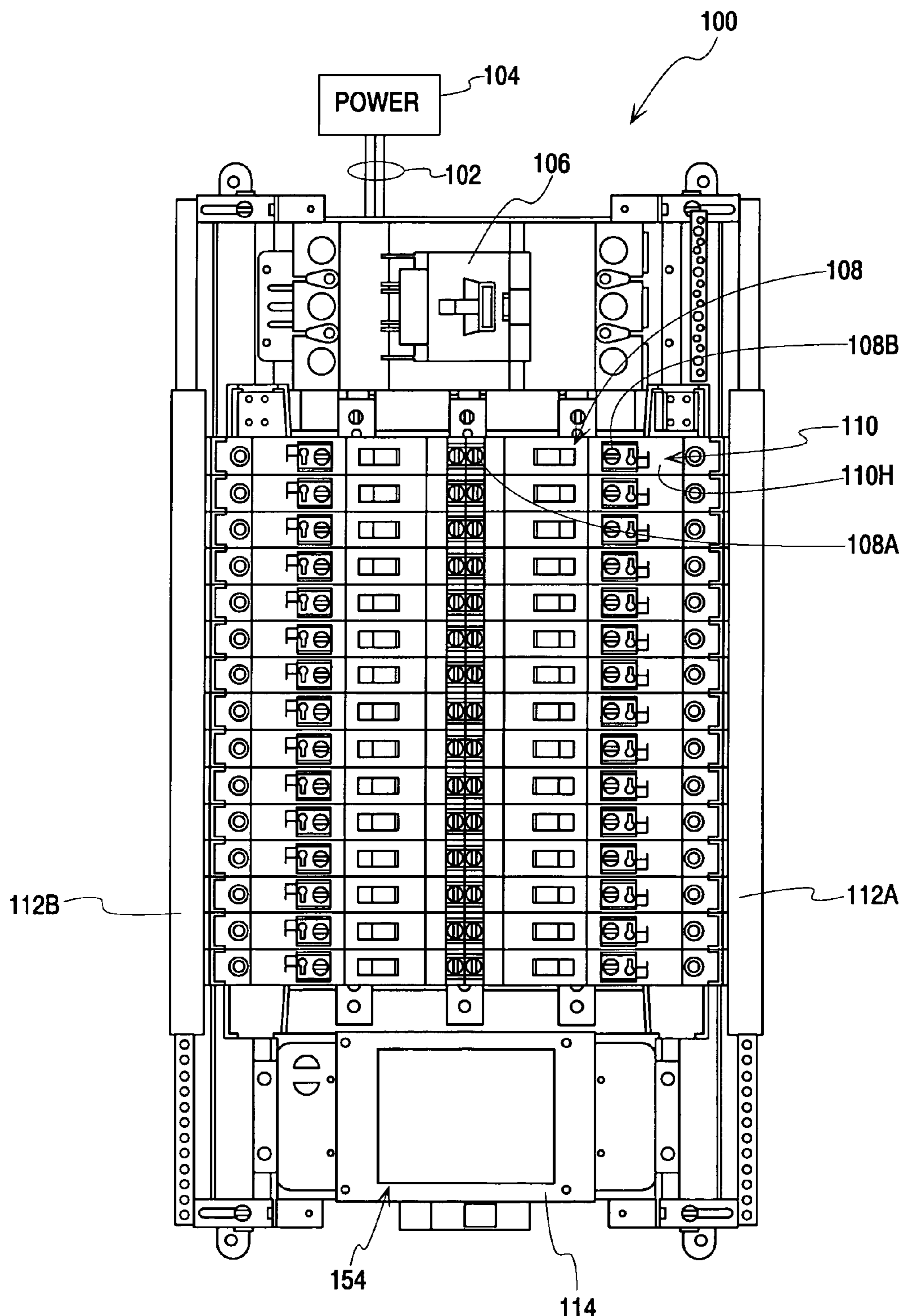

Fig. 1

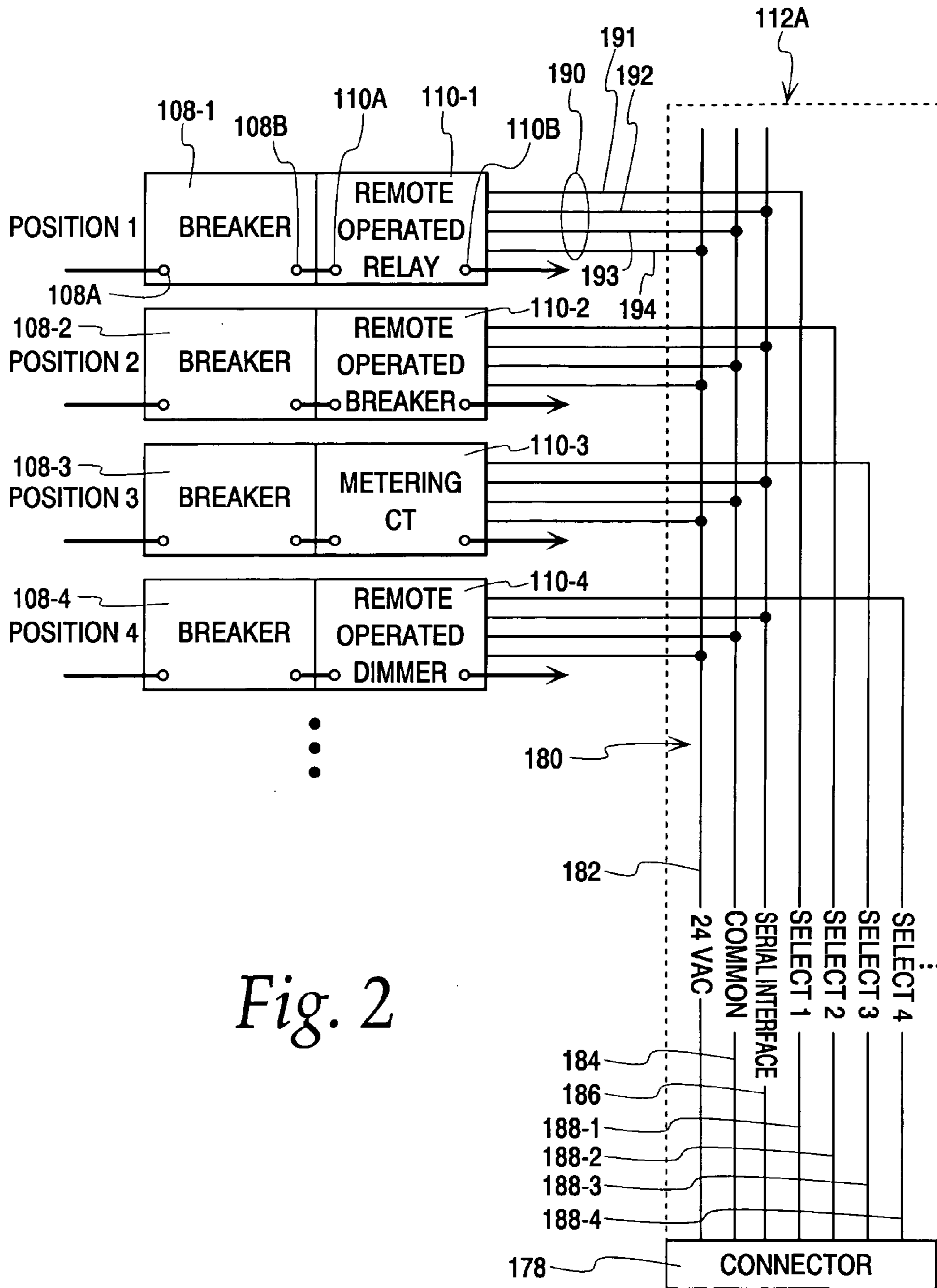

Fig. 2

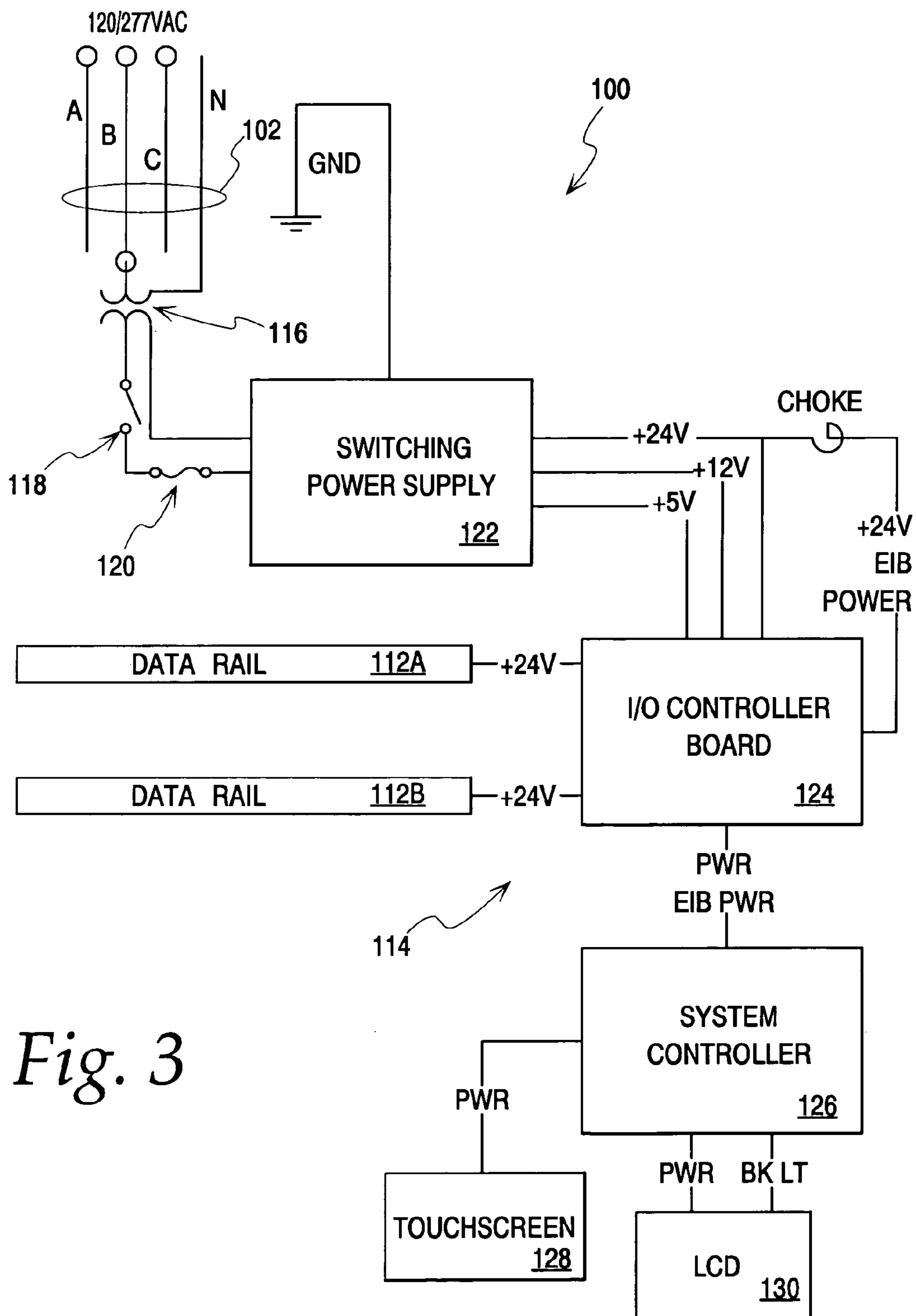
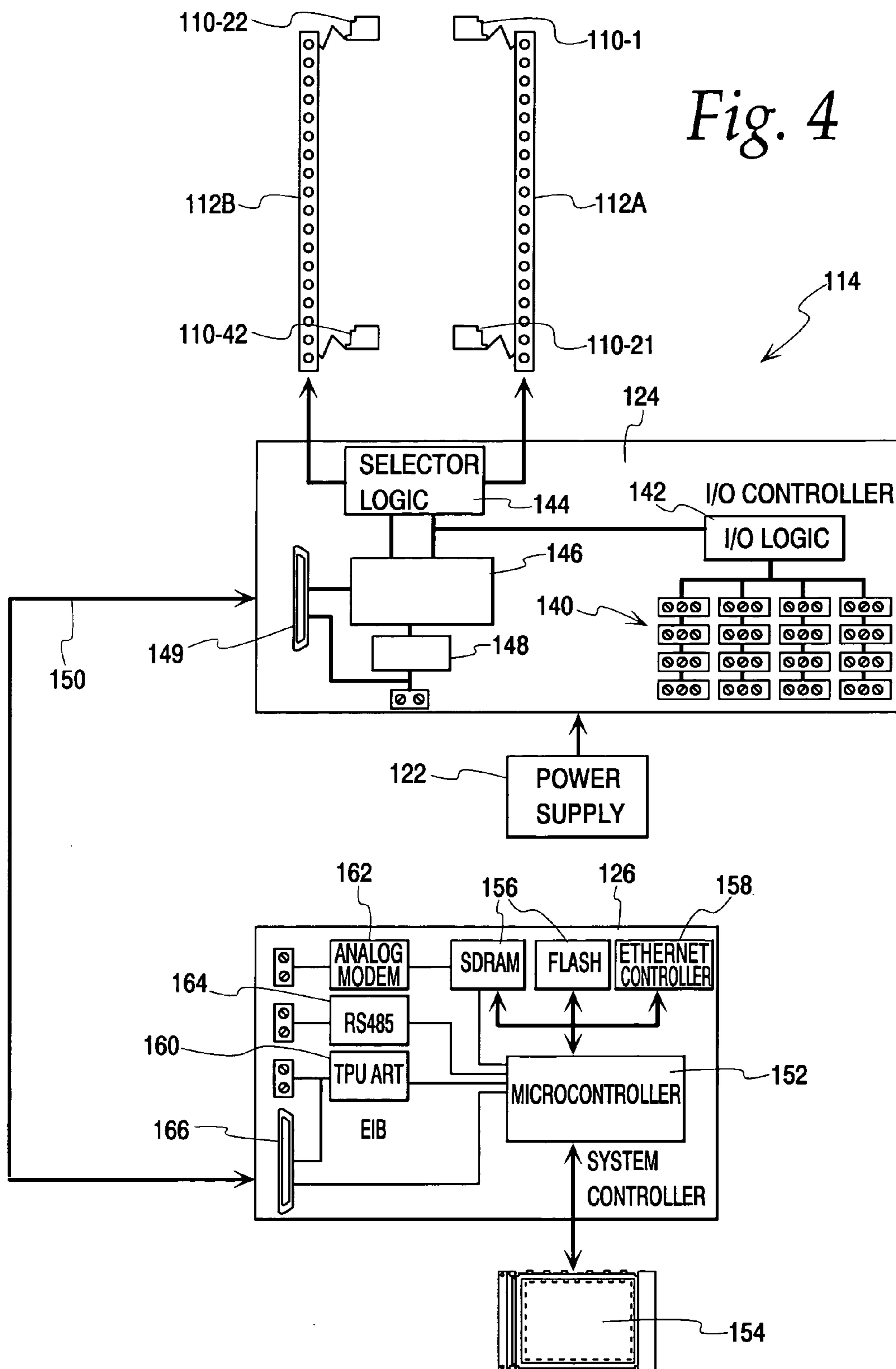

Fig. 3





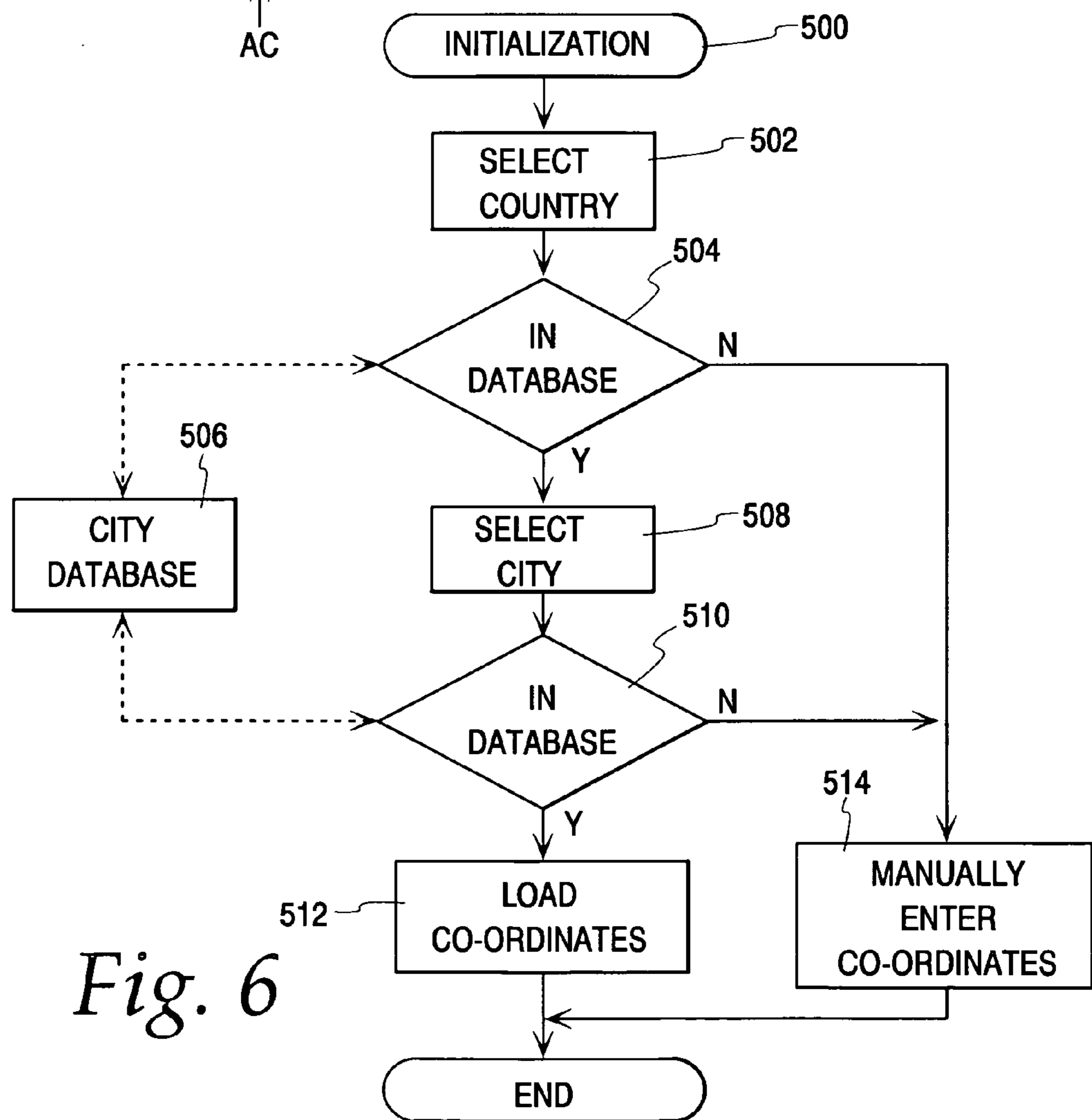
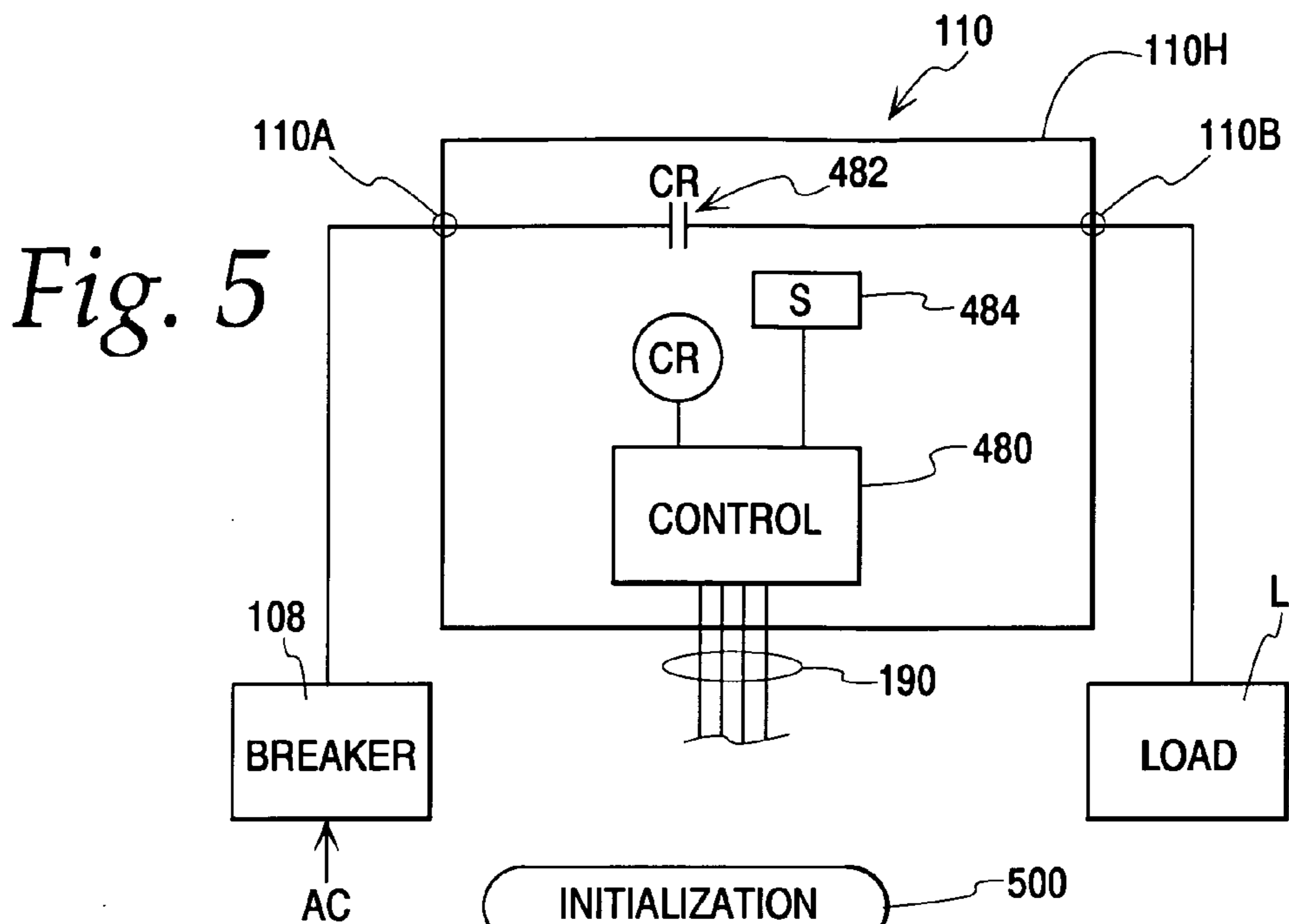

Fig. 7

Initialization	-Location
<i>Select the closest city near to you (or) specify your co-ordinates</i>	
Select Country: <span style="border: 1px solid black; padding: 2px;">USA ▾</span> <sup>700</sup>	Today: <b>5/3/2006 12:30PM</b>
Select City: <span style="border: 1px solid black; padding: 2px;">Atlanta ▾</span> <sup>702</sup>	Sunrise: <b>5:42AM</b>
	Sunset: <b>6:17PM</b>
	Longitude: <b>84.1345 N</b> <sup>704</sup>
	Latitude: <b>139.2346 E</b>
<input type="checkbox"/> Observe Daylight Savings	

Fig. 8

Initialization	-Location
<input checked="" type="radio"/> Degree <input type="radio"/> Decimal   Time Zone (+/-GMT) <span style="border: 1px solid black; padding: 2px;">+5 ▾</span> Hours	
Latitude: <span style="border: 1px solid black; padding: 2px;">33</span> <span style="border: 1px solid black; padding: 2px;">58</span> <span style="border: 1px solid black; padding: 2px;">27</span> <span style="border: 1px solid black; padding: 2px;">N ▾</span>	
Longitude: <span style="border: 1px solid black; padding: 2px;">84</span> <span style="border: 1px solid black; padding: 2px;">14</span> <span style="border: 1px solid black; padding: 2px;">6</span> <span style="border: 1px solid black; padding: 2px;">W ▾</span>	
<div style="display: flex; flex-wrap: wrap; gap: 5px;"> <span style="border: 1px solid black; padding: 2px;">1</span> <span style="border: 1px solid black; padding: 2px;">2</span> <span style="border: 1px solid black; padding: 2px;">3</span> <span style="border: 1px solid black; padding: 2px;">4</span> </div>	
<div style="display: flex; flex-wrap: wrap; gap: 5px;"> <span style="border: 1px solid black; padding: 2px;">5</span> <span style="border: 1px solid black; padding: 2px;">6</span> <span style="border: 1px solid black; padding: 2px;">7</span> <span style="border: 1px solid black; padding: 2px;">8</span> </div>	
<div style="display: flex; flex-wrap: wrap; gap: 5px;"> <span style="border: 1px solid black; padding: 2px;">9</span> <span style="border: 1px solid black; padding: 2px;">10</span> <span style="border: 1px solid black; padding: 2px;">.</span> <span style="border: 1px solid black; padding: 2px;">CLR</span> </div>	
<div style="display: flex; gap: 10px;"> <span style="border: 1px solid black; padding: 2px;"></span> <span style="border: 1px solid black; padding: 2px;"></span> </div>	

Fig. 9

Initialization	-Location
<input type="radio"/> Degree <input checked="" type="radio"/> Decimal   Time Zone (+/-GMT) <span style="border: 1px solid black; padding: 2px;">+5 ▾</span> Hours	
Latitude: <span style="border: 1px solid black; padding: 2px;">33.9742</span> <span style="border: 1px solid black; padding: 2px;">N ▾</span>	
Longitude: <span style="border: 1px solid black; padding: 2px;">84.2350</span> <span style="border: 1px solid black; padding: 2px;">W ▾</span>	
<div style="display: flex; flex-wrap: wrap; gap: 5px;"> <span style="border: 1px solid black; padding: 2px;">1</span> <span style="border: 1px solid black; padding: 2px;">2</span> <span style="border: 1px solid black; padding: 2px;">3</span> <span style="border: 1px solid black; padding: 2px;">4</span> </div>	
<div style="display: flex; flex-wrap: wrap; gap: 5px;"> <span style="border: 1px solid black; padding: 2px;">5</span> <span style="border: 1px solid black; padding: 2px;">6</span> <span style="border: 1px solid black; padding: 2px;">7</span> <span style="border: 1px solid black; padding: 2px;">8</span> </div>	
<div style="display: flex; flex-wrap: wrap; gap: 5px;"> <span style="border: 1px solid black; padding: 2px;">9</span> <span style="border: 1px solid black; padding: 2px;">10</span> <span style="border: 1px solid black; padding: 2px;">.</span> <span style="border: 1px solid black; padding: 2px;">CLR</span> </div>	
<div style="display: flex; gap: 10px;"> <span style="border: 1px solid black; padding: 2px;"></span> <span style="border: 1px solid black; padding: 2px;"></span> </div>	

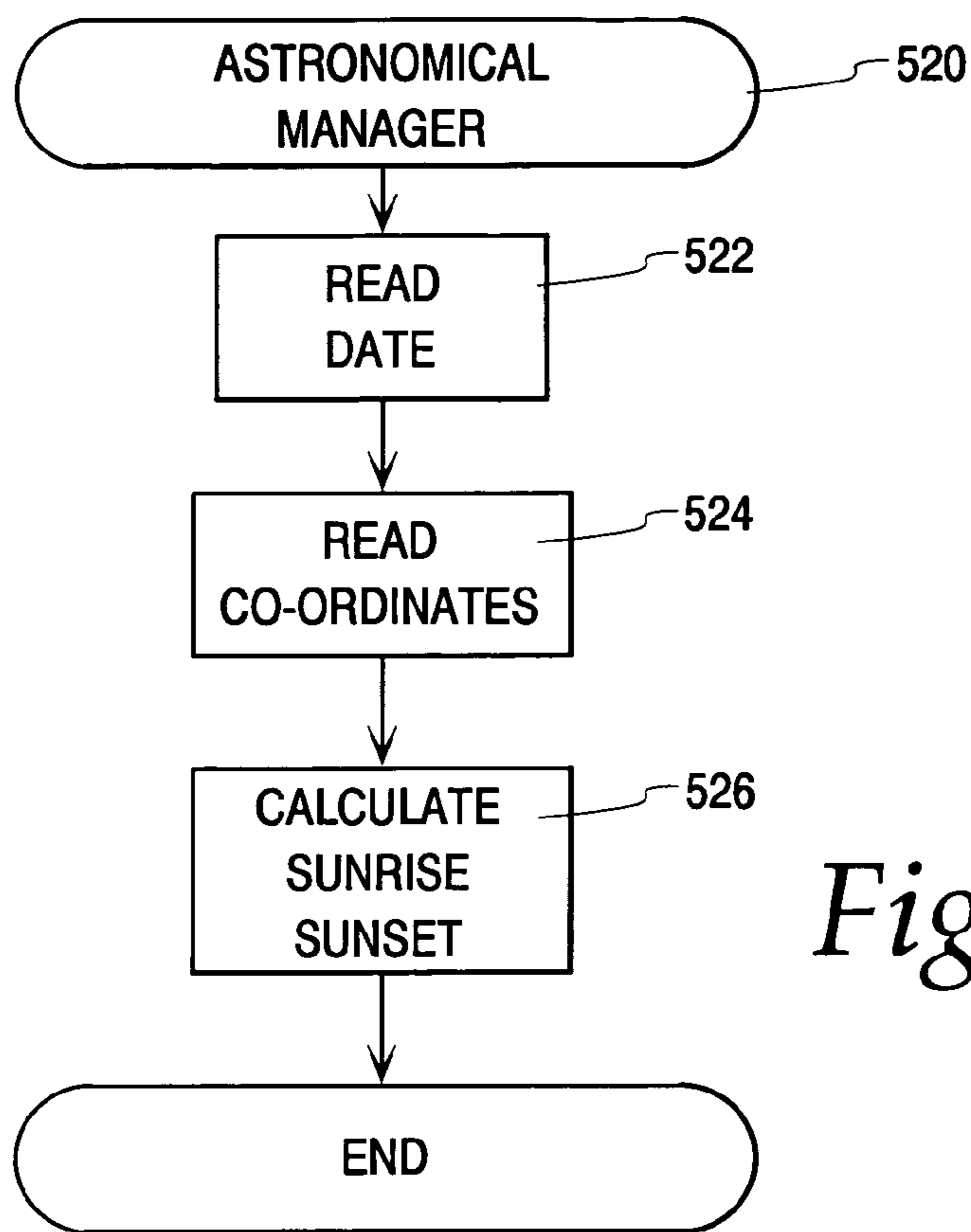

*Fig. 10*

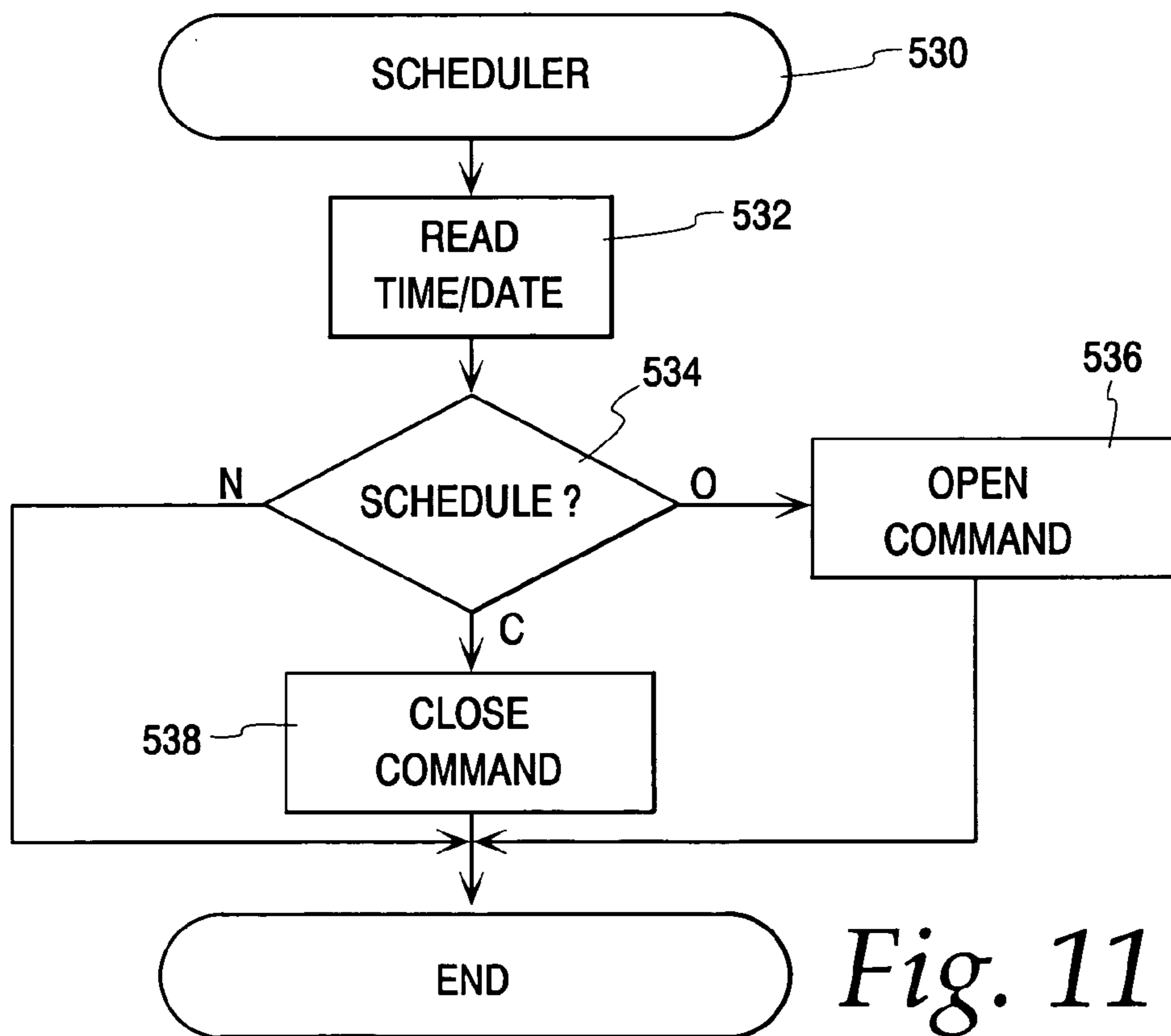

*Fig. 11*



1

**ASTRONOMICAL CALCULATIONS IN  
LIGHTING CONTROL PANEL WITH  
PRE-POPULATED CITIES**

CROSS REFERENCE TO RELATED  
APPLICATIONS

This application claims priority of provisional application No. 60/826,584 filed Sep. 22, 2006, the contents of which is incorporated by reference herein.

FIELD OF THE INVENTION

This invention relates generally to residential and commercial electrical power distribution panels and components, and more particularly, to a system and method for connecting an electrical power source to a load device using astronomical calculations.

BACKGROUND OF THE INVENTION

Circuit breaker panels are used to protect electrical circuitry from damage due to an overcurrent condition, such as an overload, a relatively high level short circuit, or a ground fault condition. To perform that function, circuit breaker panels include circuit breakers that typically contain a switch unit and a trip unit. The switch unit is coupled to the electrical circuitry (i.e., lines and loads) such that it can open or close the electrical path of the electrical circuitry. The switch unit includes a pair of separable contacts per phase, a pivoting contact arm per phase, an operating mechanism, and an operating handle.

In the overcurrent condition, all the pairs of separable contacts are disengaged or tripped, opening the electrical circuitry. When the overcurrent condition is no longer present, the circuit breaker can be reset such that all the pairs of separable contacts are engaged, closing the electrical circuitry.

In addition to manual overcurrent protection via the operating handle, automatic overcurrent protection is also provided via the trip unit. The trip unit, coupled to the switch unit, senses the electrical circuitry for the overcurrent condition and automatically trips the circuit breaker. When the overcurrent condition is sensed, a tripping mechanism included in the trip unit actuates the operating mechanism, thereby disengaging the first contact from the second contact for each phase. Typically, the operating handle is coupled to the operating mechanism such that when the tripping mechanism actuates the operating mechanism to separate the contacts, the operating handle also moves to a tripped position.

Switchgear and switchboard are general terms used to refer to electrical equipment including metal enclosures that house switching and interrupting devices such as fuses, circuit breakers and relays, along with associated control, instrumentation and metering devices. The enclosures also typically include devices such as bus bars, inner connections and supporting structures (referred to generally herein as "panels") used for the distribution of electrical power. Such electrical equipment can be maintained in a building such as a factory or commercial establishment, or it can be maintained outside of such facilities and exposed to environmental weather conditions. Typically, hinge doors or covers are provided on the front of the switchgear or switchboard sections for access to the devices contained therein.

In addition to electrical distribution and the protection of circuitry from overcurrent conditions, components have

2

been added to panels for the control of electrical power to loads connected to circuit breakers. For example, components have been used to control electrical power for lighting.

One system used for controlling electrical power to loads utilizes a remote-operated circuit breaker system. In such a system, the switch unit of the circuit breaker operates not only in response to an overcurrent condition, but also in response to a signal received from a control unit separate from the circuit breaker. The circuit breaker is specially constructed for use as a remote-operated circuit breaker, and contains a motor for actuating the switch unit.

In an exemplary remote-operated circuit breaker system, a control unit is installed on the panel and is hard-wired to the remote-operated circuit breaker through a control bus. When the switch unit of the circuit breaker is to be closed or opened, an operating current is applied to or removed from the circuit breaker motor directly by the control panel. Additional, separate conductors are provided in the bus for feedback information such as contact confirmation, etc., for each circuit breaker position in the panel. The control unit contains electronics for separately applying and removing the operating current to the circuit breakers installed in particular circuit breaker positions in the panel. The panel control unit also has electronics for checking the state of the circuit breaker, diagnostics, etc.

Lighting control systems may include a schedule program to automatically turn a light or lights on and off at select times of day according to user requirements. This can be based on occupancy trends, or the like. However, some lighting, such as exterior lighting, is advantageously turned on or off based on daylight conditions. For example, it might be desirable to turn a light on at sunset and off at sunrise. This may be accomplished by using an ambient light sensor. However, use of such sensors can be expensive to install and maintain. Alternatively, control systems can calculate sunrise and sunset time based on coordinate information such as longitude and latitude. However, this requires that the user have access to such information which is not always generally available.

The present invention is directed to improvements in electrical distribution systems using astronomical calculations with pre-populated cities.

SUMMARY OF THE INVENTION

In accordance with the invention, there is provided an electrical distribution system performing astronomical calculations with a database of pre-populated cities.

There is disclosed in accordance with one aspect of the invention an electrical distribution system for selectively connecting an electrical power source to a load device using astronomical calculations. The system comprises a switching device electrically connected between an electrical power source and a load device for selectively delivering electrical power to the load device. A control system controls operation of the switching device. The control system comprises a programmed controller for commanding operation of the switching device in accordance with a scheduling routine stored in a memory. The scheduling routine enables control of the switching device based on sunrise and sunset time. The memory further comprises a database of a plurality of geographic locations and coordinate information for the plurality of geographic locations. The control system further comprises a setup routine comprising a user interface enabling a user to select one of the plurality of geographic locations and a manager routine automatically determining sunrise and sunset times using the coordinate information



3

for the selected geographic location and providing the sunrise and sunset times to the scheduling routine.

It is a feature of the invention that the manager routine may be operated daily to determine sunrise and sunset times using the coordinate information for the selected geographic location and provide the sunrise and sunset times to the scheduling program.

It is another feature of the invention that the control system further comprises a touch screen display used by the user interface to select one of the plurality of geographic locations.

It is an additional feature of the invention that the geographic locations comprise pre-select cities.

It is a further feature of the invention that the setup routine may include a manual override enabling a user to manually enter coordinate information.

It is still another feature of the invention that the coordinate information comprises longitude, latitude and time zone of the geographic locations.

It is still a further feature of the invention to provide a panelboard and a plurality of switching devices mounted in the panelboard and wherein the control system controls operation of the plurality of switching devices in accordance with the scheduling routine.

The panelboard may support a plurality of circuit breakers, each electrically connected in series with one of the plurality of switching devices. The switching devices may be removable from the panel board separately from the control system.

It is still another feature of the invention that the switching device comprises a control relay.

There is disclosed in accordance with another aspect of the invention a lighting control system for selectively connecting an electrical power source to load devices using astronomical calculations. The system comprises a plurality of pairs of circuit breakers and switching devices each pair electrically connected between an electrical power source and a load device for selectively delivering electrical power to load devices. A control system controls operation of the switching devices. The control system comprises a programmed controller for commanding operation of the individual switching devices in accordance with a scheduling routine stored in a memory. The scheduling routine enables control of the switching devices based on sunrise and sunset time. The memory further comprises a database of a plurality of geographic locations and coordinate information for the plurality of geographic locations. The control system further comprises a setup routine comprising a user interface enabling a user to select one of the plurality of geographic locations and a manager routine automatically determining sunrise and sunset times using the coordinate information for the selected geographic location and provide any sunrise and sunset times to the scheduling program.

There is disclosed in accordance with a further aspect of the invention the method for selectively connecting an electrical power source to a load device using astronomical calculations, comprising: providing a switching device electrically connected between an electrical power source and a load device for selectively delivering electrical power to the load device; providing a programmed controller for commanding operation of the switching device in accordance with a scheduling routine stored in a memory, the scheduling routine enabling control of the switching device based on sunrise and sunset time, the programmed controller including a database of a plurality of geographic locations and coordinate information for the plurality of geographic locations; operating a user interface of the programmed control-

4

ler to select one of the plurality of geographic locations; and automatically determining sunrise and sunset times using the coordinate information for the selected geographic location and providing the sunrise and sunset times to the scheduling routine.

Further features and advantages of the invention will be readily apparent from the specification and from the drawings.

#### BRIEF DESCRIPTION OF THE DRAWINGS

FIG. 1 is an elevation view of a power distribution panel according to the invention;

FIG. 2 is a block diagram illustrating pairs of circuit breakers and remote operated devices of the power distribution panel of FIG. 1;

FIG. 3 is a block diagram of the power distribution panel of FIG. 1;

FIG. 4 is an expanded schematic/block diagram of the power distribution panel of FIG. 1;

FIG. 5 is a block diagram of a remote operated device according to the invention;

FIG. 6 is a flow diagram of an initialization routine implemented in the system controller of FIG. 4;

FIGS. 7-9 comprises a series of user interface screens used in connection with the initialization routine of FIG. 6;

FIG. 10 is a flow diagram of an astronomical manager routine implemented in the system controller of FIG. 4; and

FIG. 11 is a flow diagram of a scheduler routine implemented in the I/O controller of FIG. 4.

#### DETAILED DESCRIPTION OF THE INVENTION

An electrical distribution system, such as an integrated lighting control system, in accordance with the invention permits a user to control power circuits typically used for lighting, as well as circuits for resistive heating or air conditioning, using astronomical calculations. Control may include on/off switching, dimming and metering. The electrical distribution system may be as is generally described in U.S. application Ser. No. 11/519,727, filed Sep. 12, 2006, the specification of which is incorporated by reference herein.

Referring to FIG. 1, a lighting control system in accordance with the invention comprises a lighting control panel 100. The panel 100 may comprise a Siemens type P1 panelboard, although the invention is not limited to such a configuration. Line power enters the panel 100 through power source cables 102 connected to a source of power 104. Line power may, for example, be a three phase 480Y277, 240 or 120 VAC power source, as is conventional. The cables 102 are electrically connected to an input side of a main breaker 106. The main breaker 106 distributes line power to individual circuit breakers 108 in a conventional manner. How the power is distributed depends on design of the individual circuit breakers 108, as will be apparent to those skilled in the art. The power is distributed to the line side of individual circuit breakers 108. The panel 100 may be configured to accept up to forty two individual circuit breakers 108, although only thirty are shown in the embodiment of FIG. 1. Each circuit breaker may be of conventional construction and may be, for example, a Siemens BQD circuit breaker. Each circuit breaker 108 includes a line lug or terminal 108A receiving power from the main breaker 106 and a load lug or terminal 108B conventionally used for connecting to a load circuit.



For simplicity of description, when a device such as a circuit breaker **108** is described generally herein the device is referenced without any hyphenated suffix. Conversely, if a specific one of the devices is described it is referenced with a hyphenated suffix, such as **108-1**.

In accordance with the invention, each load circuit to be controlled also has a remote operated device **110**, such as a relay, a meter or a dimmer. The term remote operated device as used herein includes any other devices that controls, monitors or may otherwise be used in a load circuit, in accordance with the invention. While in a preferred embodiment, the remote operated device **110** is a separate component from the circuit breaker **108**, the term "remote operated device" as used herein encompasses devices integral with the circuit breaker. The remote operated devices **110** are also connected to data rails **112A** and **112B**. A panel controller **114** controls the remote operated devices **110** through connections provided via the data rails **112A** and **112B**, as discussed below.

The remote operated device **110** includes a housing **110H** encasing an auxiliary set of contacts that can be remotely operated to open and close a lighting circuit. The device **110** is attached to the load side of a circuit breaker **108** within a panel **100** using a conductor tab, i.e., the terminal **110A**, inserted into the breaker lug **108B**. The load terminal **110B** comprises a lug of the same size as the breaker lug **108B** for connecting to a wire to be connected to the load device. The device housing **110H** is configured to mount in a Siemens type P1 panelboard, although the invention is not limited to such a configuration.

Referring to FIG. 2, a block diagram illustrates four circuit breakers **108-1**, **108-2**, **108-3** and **108-4**, and respective associated remote operated devices **110-1**, **110-2**, **110-3** and **110-4**. In the illustrated embodiment, the first device **110-1** comprises a relay, the second device **110-2** comprises a breaker, the third device **110-3** comprises a current transformer, and the fourth device **110-4** comprises a dimmer. As is apparent, any combination of these remote operated devices **110** could be used. Each remote operated device **110** includes an input terminal **110A** electrically connected to the associated circuit breaker load terminal **108B**, and an output terminal **110B** for connection to a load device.

Referring to FIG. 3, a block diagram of the lighting control panel **100** is illustrated. Power from the lines **102** is provided via an isolation transformer **116**, power switch **118** and fuse **120** to a switching power supply **122**. The panel controller **114** comprises an input/output (I/O) controller **124** and optionally a system controller **126**. While the I/O controller **124** and the system controller **126** are described as separate elements, the functionality can be combined into a single controller, as will be apparent. The power supply **122** provides isolated power to all of the control components including the I/O controller **124**, the system controller **126**, and the remote operated devices **110**, see FIG. 1, via the data rails **112A** and **112B**. The I/O controller **124** and system controller **126** each have DC-DC converters deriving regulated DC voltage levels as required from the main DC output of the power supply **122**. The power supply **122** also provides 24 volts to the remote operated devices **110**. The system controller **126** is operatively connected to a touch screen **128** and an LCD **130**.

In one embodiment of the invention, shown in FIG. 4, the panel controller **114** functions as a single panel stand alone system. The I/O controller **124** supplies power and control signals through the rails **112A** and **112B** to the remote operated devices, four of which, **110-1**, **110-21**, **110-22** and

**110-42**, are illustrated. A user interface and high level scheduling and control are provided by the system controller **126**.

The I/O controller **124** provides discrete inputs to the controller **114** from dry contact switches, such as wall switches, (not shown) which can be connected to discrete input terminals **140**. The terminals **140** are organized as two inputs and a common. The inputs to the terminals **140** are detected by dry contact I/O logic **142**. A selector logic block **144** generates selector line signals and serial communications to the remote operated devices **110** via the data rails **112**. The logic blocks **142** and **144** are operatively associated with a microprocessor or microcontroller **146**. A TP-UART integrated circuit **148** provides an EIB (European Installation Bus) interface. A connector **149** allows mating directly to the system controller **126** via a cable **150**.

The system controller **126** provides the user with an application to implement lighting schedules, organize devices into logical groups, manage the inputs, and obtain status information. The system controller **126** includes a microprocessor **152** operatively connected to a user interface **154** in the form of an integrated touch screen **128** and LCD **130**, see FIG. 3. The microprocessor **152** is also connected to memory devices **156** and an ethernet controller **158**. A TP-UART circuit **160** provides an EIB interface while additional interfaces are provided via an analog modem **162** and RS **485** interface circuit **164**. A connector **162** is provided for connection to the cable **150** to transfer information between the system controller **126** and the I/O controller **124**.

Referring again to FIG. 2, a data rail **112** is illustrated schematically. The data rail **112** is mechanically attached directly to the interior of the lighting control panel **100**. The data rail **112** comprises a shielded communication bus including a ribbon connector **178** having twenty-five to twenty-nine wires to be routed to the I/O controller **124**. The ribbon connector **178** typically has twenty-six wires, two for power connection, two for ground connection, one for the serial line and up to twenty-one select lines, one for each remote operated device **110**. Each data rail **112** provides a barrier to isolate the class 1 load wires from the class 2 signal wires used to manage the devices **110**. The data rails **112** will connect to each device **110** via a connector that extends out of the device **110**. The wires are connected to lines in the form of traces on a printed circuit board **180**. A power trace **182** provides 24 volt DC power to each remote operated device **110**. A common trace **184** provides a ground to each remote operated device **110**. A serial interface trace **186** provides serial communication to each of the remote operated devices **110**. A plurality of select line traces, four of which **188-1**, **188-2**, **188-3** and **188-4** are illustrated, are provided, one for each remote operated device **110**. Each remote operated device **110** includes a four wire cable **190** for connection to the data rail **112**. The four wires comprise a select line **191** connected to one of the select traces **188**, a serial interface line **192** connected to the serial interface trace **186**, a neutral wire **193** connected to the common trace **184** and a power wire **194** connected to the power trace **182**.

In accordance with the invention, a unique select line is assigned to each breaker **108**/remote operated device **110** pair positioned within the lighting control panel **100**. Select lines are used by the I/O controller **124** to select single remote operated devices **110** to communicate via the serial interface **186** at any given time. For example, when the first select line **188-1** is asserted, the first remote operated device **110-1** listens for messages on the serial interface line **186**. Conversely, messages on the serial interface line **186** are



ignored if the first select line **188-1** is not asserted. A response by any of the remote operated devices **110** to a serial command is therefore conditional on whether its particular select line is asserted. The term “asserted”, as used herein, means one state of a signal designated to cause the remote operated device to listen for messages. In a preferred embodiment, the select line has “high” and “low” states, the high state being the asserted state.

The remote operated device **110**, in the form of a relay, allows remote switching of an electrical branch load. The device **110** is designed to fit inside a standard electrical panel board with up to forty-two branch circuit breakers **108**. The device **110** is an accessory to a branch circuit breaker **108** allowing repetitive switching of the load without effecting operation of the circuit breaker **108**.

The remote operator device **110** requires a means to receive command signals to open or close and to report back successful operation or device status. Also required is a means to drive opening and closing of the switch mechanism contacts. In accordance with the invention, the remote operated device uses two magnetically held solenoids as an actuator device and one electronic circuit board similar to a single pole device. With this design, electronic control circuitry is located inside the switching device itself. Only one circuit is needed to operate both actuators. The use of two magnetically held solenoids or “mag latches” as switching actuators results in very low energy requirements, requires short duration pulses to change position (measured in milliseconds), provides accurate and repeatable timing and requires that the control must reverse voltage polarity.

FIG. **5** illustrates a basic block diagram for load switching. The remote operated device **110**, in the form of a relay, includes a control circuit **480** connected to the cable **190**. The control circuit **480** drives a control relay CR having a normally open contact **482** connected between the terminals **110A** and **110B**. A sensor **484** senses status of the relay CR and is connected to the control circuit **480**. As such, the control circuit **480** controls operation of the contact **482** to selectively electrically connect a load L to the breaker **108**, and thus to power the load L.

The control circuit **480** comprises a conventional microcontroller and associated memory, the memory storing software to run in the control circuit **480** in accordance with commands received from the I/O controller **124**.

The software implemented in the remote operator device control circuit **480** includes various routines. This includes a start up routine executed when the control circuit **480** resets. It reads any data that has been stored in memory that needs to be modified during operations into ram variables. It turns out interrupts and otherwise initialize microcontroller operations and jumps into a status loop function.

The status loop function has several objectives. One is to keep the status data up to date to respond to status requests. Another is to run the state machine for the device, such as managing pulse widths and sequencing retry.

Pulse widths for open and close are not the same. Also, the pulse width for the open operation is not always the same, it increases by temperature/age/number of times closed. An open contacts function will set up the sequencer for an open operation placing a start open pulse task and a stop open pulse task into a sequence or queue. The open command is always executed, regardless of the detected position of the contacts, to overcome any failures in detecting the position of the contacts. A close contacts function sets up a sequencer for a close operation replacing a start close pulse task and a stop close pulse task into the sequencer queue. The close

command will always be executed, regardless of the detected position, to overcome any failures in detecting the position of the contacts.

A communications handler function runs communications protocol over the serial line. The functions include decode command, open, close, send status and send report. A report operation function assembles the data required to respond to a report operation command received on the serial line.

Communications from the I/O controller **124** to the remote operated device **110** will be master-slave, with the I/O controller **124** being the master and the devices **110** the slaves. Once the I/O controller application sends an open or closed command, it will not wait for a response from the device **110**. Rather, it hands over to the I/O sequencer queue, to perform a status check at a later time. This allows some time for the device **110** to settle down with its new status.

In the case of sending open or closed commands to more than one device **110** at the same time, one open command does the job after the I/O controller **124** enables the respective device select lines. For example, the I/O controller **124** might turn on the select line for devices **110-4**, **110-7**, **110-9**, then send out one open command. Devices **110-4**, **110-7** and **110-9** would all see the open command and attempt to open the mag latch.

In accordance with the invention, the system controller **126** provides a user interface application via the touch panel user interface **154** for the user to configure the system. This configuration includes setting up panels, breakers, zones, inputs, I/O mappings, schedules and overrides. As part of the set up process, schedules can be made based on sunrise and sunset times at any given location. The sunrise and sunset times are calculated based on the longitude, latitude and time zone of the location on a given day.

Schedules can be set up in the lighting control system **100** through the system controller **126** such that a remote operated device **110**, or group of devices **110**, can be turned on or off based on a sunrise or sunset time. Once a schedule is set up, then the sunrise and sunset times are automatically calculated for the location on a daily basis and the remote operated devices **110** are switched on or off based on how the schedule is set up.

Referring to FIG. **6**, a flow diagram illustrates an initialization routine **500** implemented in the system controller microcontroller **152**, see FIG. **4**. The initialization routine uses a database stored in the system controller memory **156**. The database comprises a pre-populated list of cities and coordinate information for each city. The coordinate information comprises longitude, latitude and time zone for the location of the city. A user can choose the nearest city during the set up process. This eliminates requiring the user to find out the longitude and latitude and time zone for the particular location.

FIG. **7** illustrates a user interface screen displayed on the user interface **154**, see FIG. **4**, during the initialization routine **500**. The routine begins at a block **502** where the user selects a country at a location **700** on the LCD screen. A decision block **504** determines if the country is in the database by accessing a database block **506**. If so, then a city list is populated at a location **702** on the screen display. A user then selects from the list of cities at a block **508**. A decision block **510** determines if the city is in the database. If so, then the coordinates for the city are loaded at a block **512** and displayed at screen display location **704**, along with current time and date. This longitude and latitude and time zone are then used, as described below, to determine sunrise and sunset time which are displayed likewise as at **704**.



If the country or city are not present in the database **506**, then the user can choose “other” in the country or city and specify the exact longitude and latitude information of the location. This is done at the block **514** of FIG. **6**. The user can manually specify the longitude and latitude information in degree format, as illustrated in FIG. **8**, or decimal format, as illustrated in FIG. **9**. Particularly, the user manually enters the latitude, longitude and time zone using a touch screen keypad.

FIG. **10** illustrates a flow diagram for an astronomical manager routine **520** implemented in the system controller **126** for calculating sunrise and sunset times. The routine begins at a block **522** which reads the current date. A block **524** reads the coordinates loaded during the initialization routine **500** at the block **512**, see FIG. **6**. A block **526** calculates the sunrise and sunset times. This calculation is performed daily. The sunrise and sunset times may be calculated using a conventional sunrise/sunset calculator and calculations may, for example, be based on equations from “Astronomical Algorithm” by Jean Meeus or as available from the National Oceanic & Atmospheric Administration Surface Radiation Research Branch.

The calculated sunrise and sunset times can then be delivered to the I/O controller **124** for use in implementing a scheduler routine **530**.

FIG. **11** illustrates a flow diagram for the scheduler routine **530** in the I/O controller **124**. The scheduler routine **530** begins at a block **532** which reads the current time and date based on a real time clock. A schedule block **534** determines if the time and date corresponds to an on or off time for any particular load device. For example, the schedule can be based on a specific preloaded time or based on sunrise or sunset time. If based on sunrise or sunset time, then the current day’s sunrise and sunset time are read and used to make a determination. If it is necessary to issue an open command, then the open command is issued at a block **536**. If a close command should be issued, then a close command is generated at a block **538**. The open command or close command are transmitted to the particular remote operated device **110**, as required in accordance with the schedule. If no change is required, then the routine ends.

Thus, in accordance with the invention, sunrise and sunset times are calculated based on longitude and latitude and time zone of a particular location selected from a database pre-populated with designated cities and countries.

The present invention has been described with respect to flowcharts and block diagrams. It will be understood that each block of the flowchart and block diagrams can be implemented by computer program instructions. These program instructions may be provided to a processor to produce a machine, such that the instructions which execute on the processor create means for implementing the functions specified in the blocks. The computer program instructions may be executed by a processor to cause a series of operational steps to be performed by the processor to produce a computer implemented process such that the instructions which execute on the processor provide steps for implementing the functions specified in the blocks. Accordingly, the illustrations support combinations of means for performing a specified function and combinations of steps for performing the specified functions. It will also be understood that each block and combination of blocks can be implemented by special purpose hardware-based systems which perform the specified functions or steps, or combinations of special purpose hardware and computer instructions.

We claim:

**1.** An electrical distribution system for selectively connecting an electrical power source to a load device using astronomical calculations, comprising:

- a switching device electrically connected between an electrical power source and a load device for selectively delivering electrical power to the load device;
- a control system for controlling operation of the switching device, the control system comprising a programmed controller for commanding operation of the switching device in accordance with a scheduling routine stored in a memory, the scheduling routine enabling control of the switching device based on sunrise and sunset time, the memory further comprising a database of a plurality of geographic locations and coordinate information for the plurality of geographic locations, the control system further comprising a setup routine comprising a user interface displaying a list of available geographic locations and enabling a user to select one of the plurality of geographic locations and a manager routine automatically operable each day to calculate sunrise and sunset times for the day using the coordinate information, comprising latitude, longitude and time zone, for the selected geographic location and providing the sunrise and sunset times to the scheduling routine.

**2.** The electrical distribution system of claim **1** wherein the manager routine is operated daily to determine sunrise and sunset times using the coordinate information for the selected geographic location and provide the sunrise and sunset times to the scheduling routine.

**3.** The electrical distribution system of claim **1** wherein the control system further comprises a touch screen display used by the user interface to select one of the plurality of geographic locations.

**4.** The electrical distribution system of claim **1** wherein the geographic locations comprise preselect cities.

**5.** The electrical distribution system of claim **1** wherein the setup routine includes a manual override enabling a user to manually enter coordinate information.

**6.** The electrical distribution system of claim **1** wherein the control system comprises a display displaying calculated sunrise and sunset time.

**7.** The electrical distribution system of claim **1** further comprising a panelboard and a plurality of switching devices mounted in the panelboard and wherein the control system controls operation of the plurality of switching devices in accordance with the scheduling routine.

**8.** The electrical distribution system of claim **7** wherein the panelboard supports a plurality of circuit breakers, each electrically connected in series with one of the plurality of switching devices.

**9.** The electrical distribution system of claim **7** wherein the switching devices are removable from the panelboard separately from the control system.

**10.** The electrical distribution system of claim **1** wherein the switching device comprises a control relay.

**11.** A lighting control system for selectively connecting an electrical power source to load devices using astronomical calculations, comprising:

- a panelboard;
- a plurality of pairs of circuit breakers and switching devices modules mounted in the panelboard, each pair electrically connected between an electrical power source and a load device for selectively delivering electrical power to load devices;
- a control system mounted in the panelboard and electrically connected to the switching devices for controlling operation of the switching devices, the control system



**11**

comprising a programmed controller for commanding operation of the individual switching devices in accordance with a scheduling routine stored in a memory, the scheduling routine enabling control of the switching devices based on sunrise and sunset time, the memory further comprising a database of a plurality of geographic locations and coordinate information for the plurality of geographic locations, the control system further comprising a setup routine comprising a user interface enabling a user to select one of the plurality of geographic locations and a manager routine automatically determining sunrise and sunset times using the coordinate information for the selected geographic location and providing the sunrise and sunset times to the scheduling routine.

**12.** The lighting control system of claim **11** wherein the manager routine is operated daily to determine sunrise and sunset times using the coordinate information for the selected geographic location and provide the sunrise and sunset times to the scheduling routine.

**13.** The lighting control system of claim **11** wherein the control system further comprises a touch screen display used by the user interface to select one of the plurality of geographic locations.

**14.** The lighting control system of claim **11** wherein the setup routine includes a manual override enabling a user to manually enter coordinate information.

**15.** The lighting control system of claim **11** wherein the coordinate information comprises longitude, latitude and time zone of the geographic locations.

**16.** The lighting control system of claim **11** wherein the switching devices are individually removable from the panelboard separately from circuit breakers and the control system.

**17.** The method for selectively connecting an electrical power source to a load device using astronomical calculations, comprising:

**12**

providing a switching device electrically connected between an electrical power source and a load device for selectively delivering electrical power to the load device;

providing a programmed controller for commanding operation of the switching device in accordance with a scheduling routine stored in a memory, the scheduling routine enabling control of the switching device based on sunrise and sunset time, the programmed controller including a database of a plurality of geographic locations and coordinate information for the plurality of geographic locations;

operating a user interface of the programmed controller to display a listing of available geographic locations to enable a user to select one of the plurality of geographic locations; and

automatically each day calculating sunrise and sunset times using the coordinate information for the selected geographic location and providing the sunrise and sunset times to the scheduling routine.

**18.** The method of claim **17** wherein the step of automatically determining sunrise and sunset times using the coordinate information for the selected geographic location and providing the sunrise and sunset times to the scheduling program is performed daily.

**19.** The method of claim **17** further comprising manually entering coordinate information if a desired geographic location is not stored in the database.

**20.** The method of claim **17** wherein the coordinate information comprises longitude, latitude and time zone of the geographic locations.

\* \* \* \* \*