



US007381008B2

(12) **United States Patent**
Shaw et al.

(10) **Patent No.:** **US 7,381,008 B2**
(45) **Date of Patent:** ***Jun. 3, 2008**

(54) **DISK PLATE CONCRETE DOWEL SYSTEM**

2,166,220 A 7/1939 Older

(76) Inventors: **Lee A. Shaw**, 2672 Crestview Dr.,
Newport Beach, CA (US) 92663;
Ronald D. Shaw, 1401 Outrigger,
Corona Del Mar, CA (US) 92625

(Continued)

FOREIGN PATENT DOCUMENTS

EP 1 123 443 1/2004

(Continued)

OTHER PUBLICATIONS

www.pna-inc.com; "The Diamond Dowel System"; May 22, 2003;
2 pages.

(Continued)

(*) Notice: Subject to any disclaimer, the term of this
patent is extended or adjusted under 35
U.S.C. 154(b) by 176 days.

This patent is subject to a terminal dis-
claimer.

(21) Appl. No.: **11/394,788**

Primary Examiner—Raymond W Addie

(22) Filed: **Mar. 31, 2006**

(74) *Attorney, Agent, or Firm*—Stetina Brunda Garred &
Brucker

(65) **Prior Publication Data**

(57) **ABSTRACT**

US 2006/0185286 A1 Aug. 24, 2006

Related U.S. Application Data

(63) Continuation of application No. 11/103,863, filed on
Apr. 12, 2005, now abandoned, which is a continu-
ation of application No. 10/640,556, filed on Aug. 13,
2003, now Pat. No. 6,926,463.

(51) **Int. Cl.**
E01C 11/14 (2006.01)

(52) **U.S. Cl.** 404/60; 404/51; 404/58;
404/61; 404/64; 404/65

(58) **Field of Classification Search** 404/51,
404/58, 60, 64, 61, 65, 66, 68
See application file for complete search history.

(56) **References Cited**

U.S. PATENT DOCUMENTS

754,215 A 3/1904 Hayward
2,096,702 A 10/1937 Yeoman

Disclosed is a disc dowel system interposed between adja-
cent first and second concrete pours defining a pour joint
therebetween. The disc dowel system comprises a positioner
bracket, a pocket former and a dowel plate. The positioner
bracket has a vertically disposed base flange and a horizon-
tally disposed plate portion extending therefrom. The base
flange is rigidly attachable to a concrete form. The pocket
former has a horizontally extending interior compartment
with an open, generally straight side and an arch-shaped
compartment perimeter extending therefrom. The straight
side is aligned with the pour joint. The pocket former is
positioned within the first pour by the positioner bracket.
The dowel plate has a generally rounded shape with an
embed portion and a slidable portion. The embed portion is
rigidly encapsulated within the second pour and the slidable
portion is slidably disposed within the pocket former such
that the dowel plate permits relative horizontal movement of
the first and second pours while restricting relative vertical
movement thereof.

16 Claims, 2 Drawing Sheets

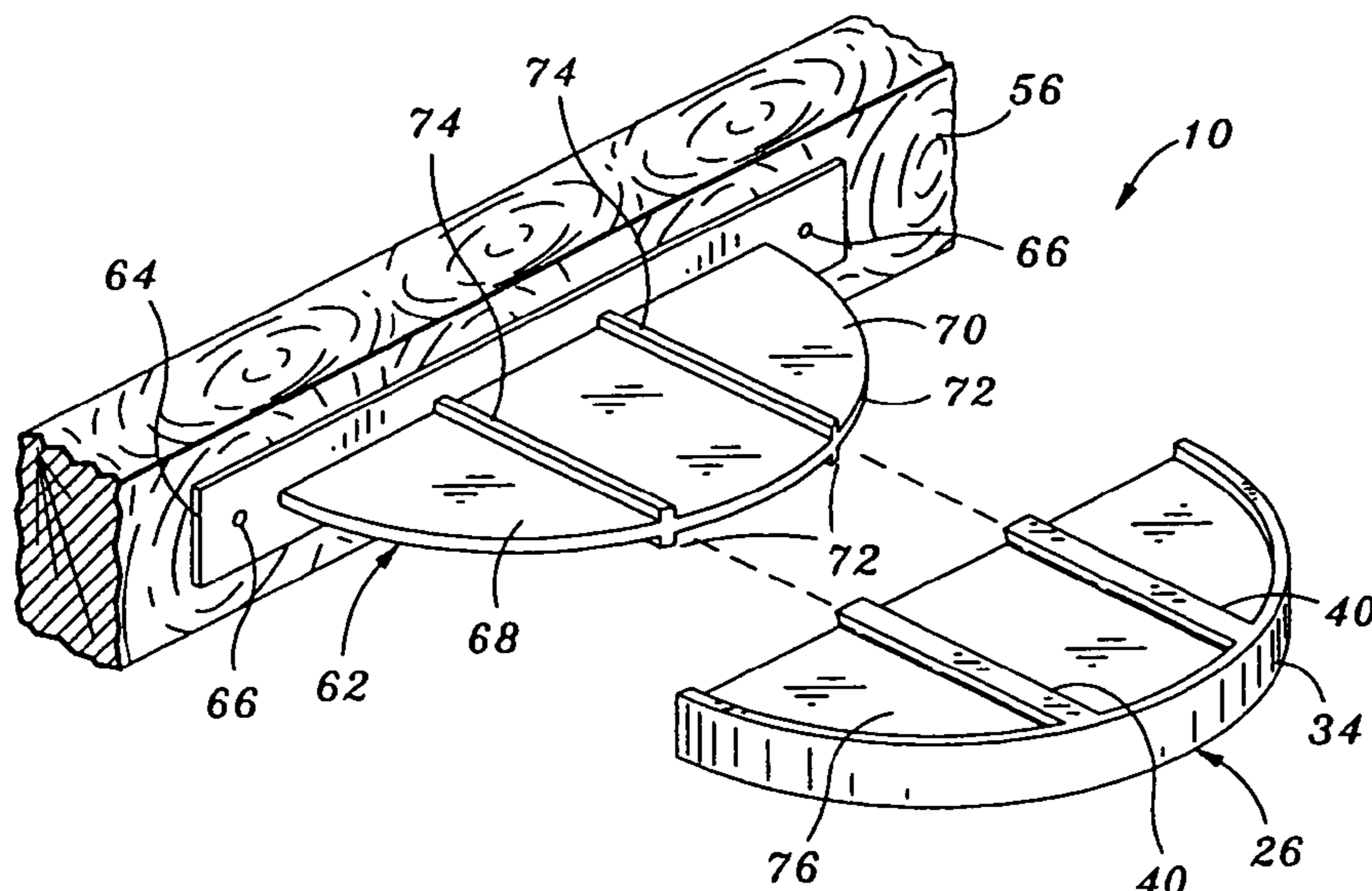

US 7,381,008 B2

Page 2

U.S. PATENT DOCUMENTS

2,181,005 A 11/1939 Westcott
4,077,177 A 3/1978 Boothroyd et al.
4,087,072 A 5/1978 Olsen
4,252,767 A 2/1981 Piazza et al.
4,493,584 A 1/1985 Guntert
4,657,430 A * 4/1987 Marionneaux 404/74
4,801,425 A 1/1989 Michel et al.
5,005,331 A 4/1991 Shaw et al.
5,046,898 A 9/1991 McKinney
5,096,155 A 3/1992 Fitzgerald
5,205,942 A 4/1993 Fitzgerald
5,216,862 A 6/1993 Shaw et al.
5,487,249 A 1/1996 Shaw et al.
5,678,952 A 10/1997 Shaw et al.
5,694,730 A 12/1997 Del Rincon et al.
5,934,821 A 8/1999 Shaw et al.
D419,700 S 1/2000 Shaw et al.
6,018,833 A 2/2000 Imm
6,123,485 A 9/2000 Mirmiran et al.
6,145,262 A 11/2000 Schrader et al.

6,210,070 B1 4/2001 Shaw et al.
6,243,994 B1 6/2001 Bernini
6,354,053 B1 * 3/2002 Kerrels 52/396.04
6,354,760 B1 3/2002 Boxall et al.
D459,205 S 6/2002 Shaw et al.
6,517,277 B2 2/2003 Hu et al.
6,655,869 B1 12/2003 Deeb et al.
6,926,463 B2 8/2005 Shaw et al.
7,004,443 B2 * 2/2006 Bennett 249/185

FOREIGN PATENT DOCUMENTS

EP 1 389 648 2/2004
WO PCT/F199/00865 4/2000

OTHER PUBLICATIONS

www.pavement.com; "Load Transfer"; May 27, 2003; 2 pages.
www.danley.com; "Danley Diamond Dowel System"; 2 pages.
Wayne W. Walker/Jerry A. Holland; "Plate Dowels for Slabs on
Ground"; 4 pages.

* cited by examiner

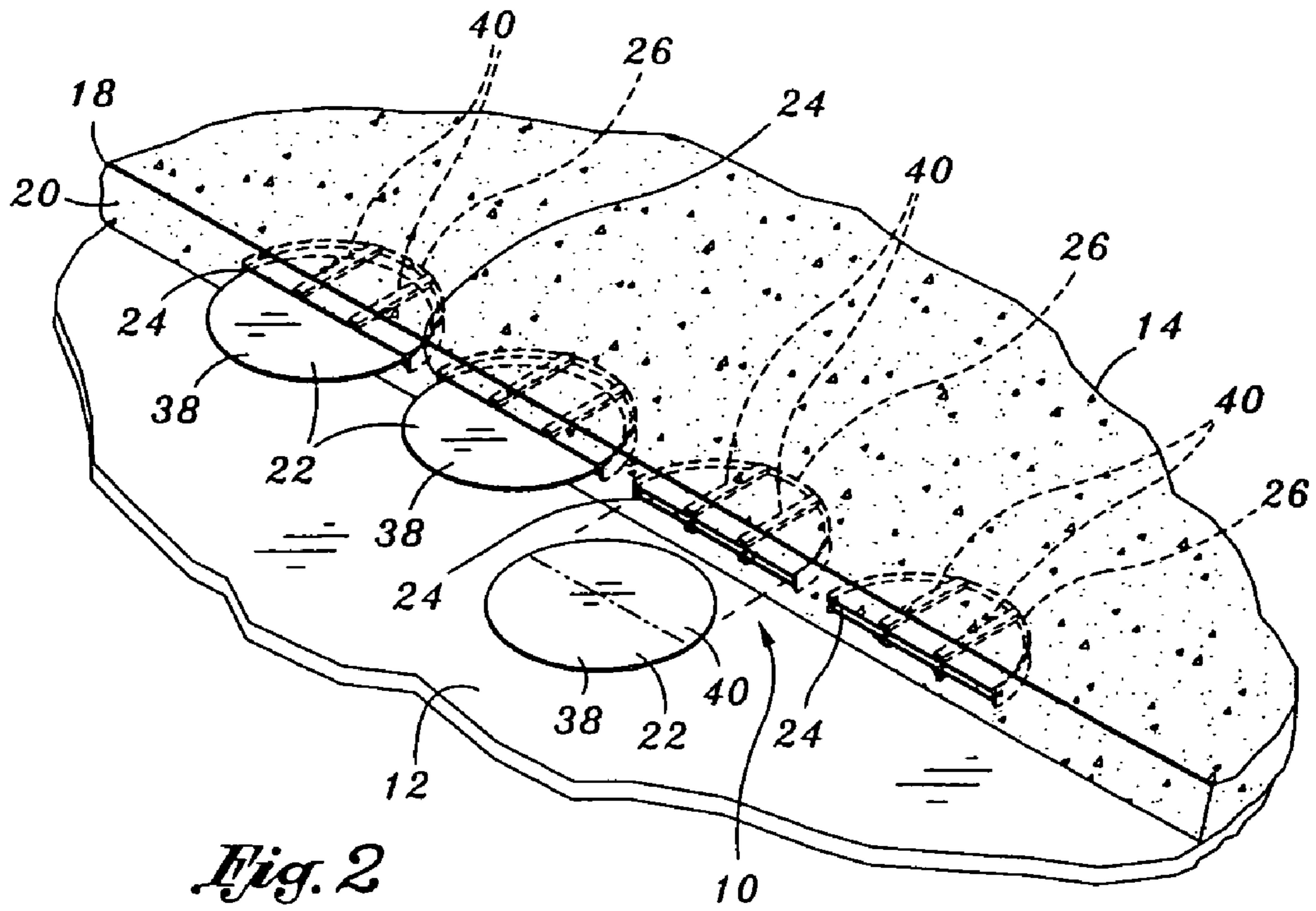
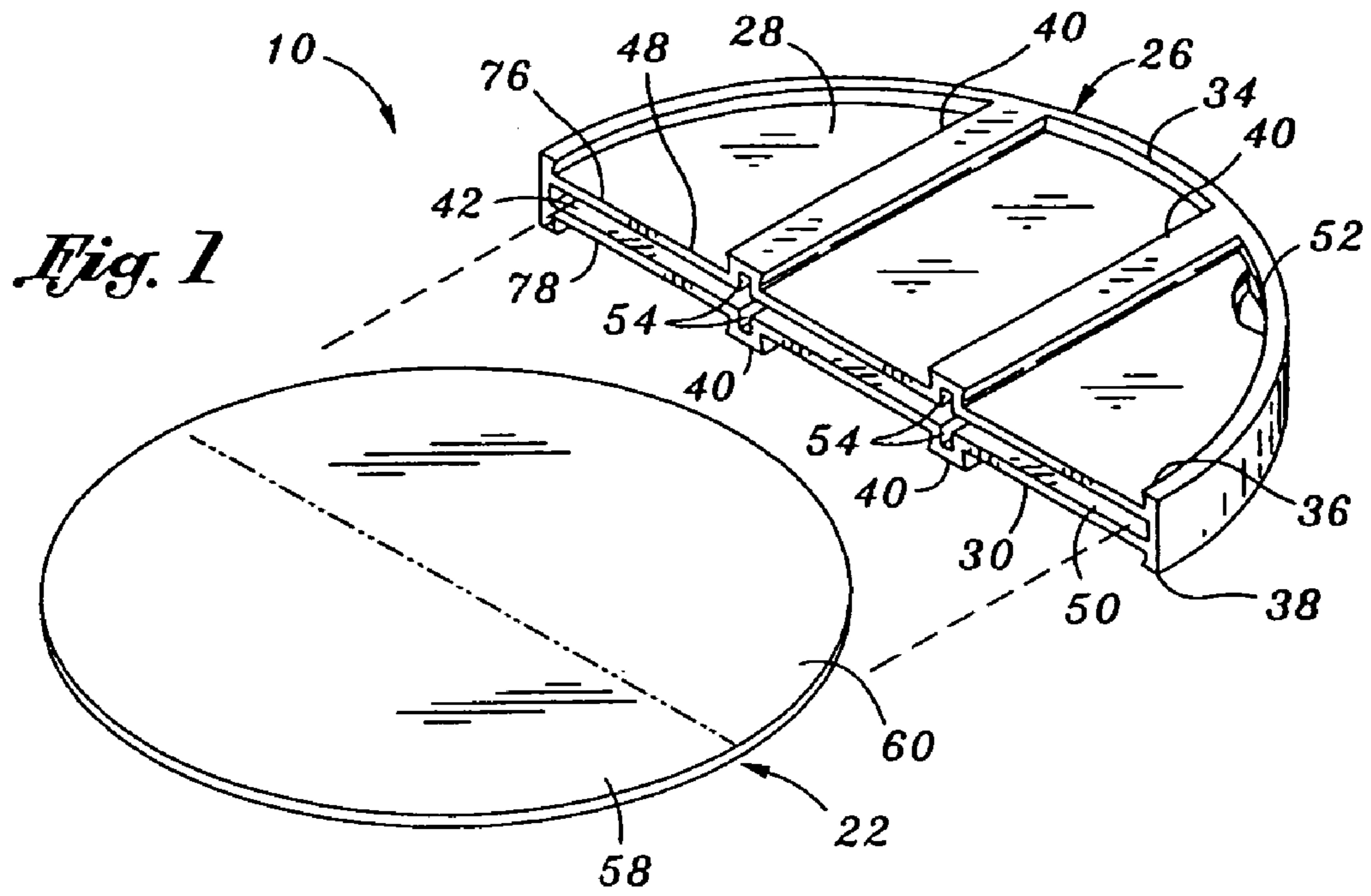

DISK PLATE CONCRETE DOWEL SYSTEM**CROSS-REFERENCE TO RELATED APPLICATIONS**

This application is a continuation of U.S. application Ser. No. 11/103,863, entitled DISC PLATE CONCRETE DOWEL SYSTEM, filed on Apr. 12, 2005, now abandoned which is a continuation of U.S. application Ser. No. 10/640,556, also entitled DISC PLATE CONCRETE DOWEL SYSTEM and filed on Aug. 13, 2003, now U.S. Pat. No. 6,926,463, the entire contents of each being expressly incorporated by reference herein.

STATEMENT RE: FEDERALLY SPONSORED RESEARCH/DEVELOPMENT

(Not Applicable)

BACKGROUND OF THE INVENTION

The present invention relates generally to concrete forming equipment and, more particularly, to a uniquely configured disc dowel system that is specifically adapted to prevent relative vertical movement of adjacently disposed concrete slabs.

During construction of concrete pavement such as for sidewalks, driveways, roads and flooring in buildings, cracks may occur due to uncontrolled shrinkage or contraction of the concrete. Such cracks are the result of a slight decrease in the overall volume of the concrete as water is lost from the concrete mixture during curing. Typical contraction rates for concrete are about one-sixteenth of an inch for every ten feet of length. Thus, large cracks may develop in concrete where the overall length of the pavement is fairly large. In addition, the cracks may continue to develop months after the concrete is poured due to induced stresses in the concrete.

One of the most effective ways of controlling the location and direction of the cracks is to include longitudinal control joints or contraction joints in the concrete. Contraction joints are typically comprised of forms having substantially vertical panels that are positioned above the ground or subgrade and held in place utilizing stakes that are driven into the subgrade at spaced intervals. The forms act to subdivide or partition the concrete into multiple sections or slabs that allow the concrete to crack in straight lines along the contraction joint. By including contraction joints, the slabs may move freely away from the contraction joint during concrete shrinkage and thus prevent random cracking elsewhere.

In one system of concrete construction, forms are installed above the subgrade to create a checkerboard pattern of slabs. A first batch of wet concrete mixture is poured into alternating slabs of the checkerboard pattern. After curing, forms may be removed and the remaining slabs in the checkerboard pattern are poured from a second batch of concrete. Although effective in providing longitudinal contraction joints to prevent random cracking, the checkerboard system of concrete pavement construction is both labor intensive and time consuming due to the need to remove the forms and due to the waiting period between the curing of the first batch and the pouring of the second batch of concrete.

In another system of concrete construction known as monolithic pour technique, the pour joints are installed above the subgrade in the checkerboard pattern. However,

all of the slabs of the checkerboard pattern are poured in a single pour thereby reducing pour time as well as increasing labor productivity. An upper edge of the forms then serves as a screed rail for striking off or screeding the surface of the concrete so that the desired finish or texture may be applied to the surface before the concrete cures. The pour joints, comprised of vertically disposed forms, remain embedded in the concrete and provide a parting plane from which the slabs may move freely away during curing. The pour joints additionally allowing for horizontal displacement of the slabs caused by thermal expansion and contraction of the slabs during normal everyday use.

Unfortunately, vertical displacement of adjacent slabs may also occur at a joint due to settling or swelling of the substrate below the slab or as a result of vertical loads created by vehicular traffic passing over the slabs. The vehicular traffic as well as the settling or swelling of the subgrade may create a height differential between adjacent slabs. Such height differential may result in an unwanted step or fault in a concrete sidewalk or roadway or in flooring of a building creating a pedestrian or vehicular hazard. Furthermore, such a step may allow for the imposition of increased stresses on the corner of the concrete slab at the joint resulting in degradation and spalling of the slab. In order to limit relative vertical displacement of adjacent slabs such that steps are prevented from forming at the joints, a form of vertical load transfer between the slabs is necessary.

One system for limiting relative vertical displacement and for transferring loads between slabs is provided by key joints. In key joint systems, the form is configured to impart a tongue and groove shape to respective ones of adjacent slabs. Typically preformed of steel, such a key joint imparts the tongue and groove shape to adjacent slabs in order to allow for contraction and expansion of the adjacent slabs while limiting the relative vertical displacement thereof due to vertical load transfer between the tongue and groove. The tongue of one slab is configured to mechanically interact with the mating groove of an adjacent slab in order to provide reactive shear forces across the joint when a vertical load is placed on one of the slabs. In this manner, the top surfaces of the adjacent slabs are maintained at the same level despite swelling or settling of the subgrade underneath either one of the slabs. Additionally, edge stresses of each of the slabs are minimized such that chipping and spalling of the slab corners may be reduced.

Although the key joint presents several advantages regarding its effectiveness in transferring loads between adjacent slabs, key joints also possess certain deficiencies that detract from their overall utility. Perhaps the most significant of these deficiencies is that the tongue of the key joint may shear off under certain loading conditions. Furthermore, the face of the key joint may spall or crack above or below the groove under load. The location of the shearing or spalling is dependent on whether the load is applied on the tongue side of the joint or the groove side of the joint. If the vertical load is applied on the tongue side, the failure will occur at the bottom portion of the groove. Conversely, if the vertical load is applied on the groove side of the joint, the failure will occur near the upper surface of the slab upon which the load is applied.

Shear failure of the tongue and groove may also occur due to opening of the key joint as a result of shrinkage of the concrete slab. As the key joint opens up over time, the groove side may become unsupported as the tongue moves away. Vertical loading of this unsupported concrete causes cracking and spalling parallel to the joint. Such cracking and spalling may occur rapidly if hard-wheeled traffic such as

forklifts are moving across the joint. Another deficiency associated with key joint systems is related to the size, configuration and vertical placement of the tongue and groove within the key joint. If excessively large key joints are formed in adjacent slabs or if the tongue and groove are biased toward an upper surface of the slabs instead of being placed at a more preferable midheight location, spalls may occur at the key joint. Such spalls occurring from this type of deficiency typically run the entire length of the longitudinal key joint and are difficult to repair.

Other systems for limiting relative vertical displacement and for transferring loads between adjacent slabs involve methods of placing slip dowels within edge portions of the slabs across a pour joint as disclosed in U.S. Pat. Nos. 5,487,249, 5,678,952, 5,934,821, 6,210,070, 5,005,331, D419,700 and D459,205, each of which is issued to Shaw et al. Each one of these patents discloses various alternatives for installing slip dowels across the pour joint. The slip dowels are typically configured as smooth steel dowel rods that are placed within the edge portions in a manner such that the concrete slabs may slide freely along the slip dowels thereby permitting expansion and contraction of the slabs while simultaneously maintaining the slabs in a common plane and thus prevent unevenness or steps from forming at the joint. However, in order to function effectively, the slip dowels must be accurately positioned parallel within the adjoining concrete slabs. The positioning of the slip dowels in a non-parallel fashion prevents the desired slippage and thus defeats the purpose of the slip dowel system.

In addition, the individual dowel rods must be placed within one or both of the slabs in such a manner such as to permit continual slippage or movement of the dowel rod within the cured concrete slab(s). Unfortunately, because such slip dowels must be perfectly aligned in order to allow the adjacent concrete slabs to slide freely away from the joint, installation of slip dowels is labor intensive. In addition, slip dowels allow movement of the concrete slabs in one direction only (i.e., normal to the joint) while not permitting any lateral movement of the slabs (i.e., parallel to the joint) which may result in cracking of the slabs outside of the joint. Furthermore, because the dowel rods are extended outwardly from each side of the joint prior to pouring of the concrete and because of their relatively small diameter, the dowel rods present a safety hazard to personnel who may be injured by contact with rough, exposed ends of the dowel rods. Finally, such dowel rods may be accidentally bent as a result of contact with equipment and site traffic during construction resulting in misalignment of the dowel rods and locking of the joint.

In an effort to alleviate the labor intensive installation and inherently hazardous nature of the above-described slip dowel system as well as allow the slabs to move both normally and laterally relative to the joint, a diamond plate dowel system has been developed for limiting relative vertical displacement and for transferring loads between slabs. The diamond plate dowel system is typically comprised of a pocket former that is attached to a side of a concrete form such as a wooden form. The pocket former is configured such that opposing corners of the diamond plate are aligned with the joint. After pouring the slab on one side of the joint which encases the pocket therein, a diamond shaped plate is inserted into the pocket former immediately prior to pouring the abutting slab on the opposite side of the joint. The diamond plate allows the slabs to move unrestrained both normally and laterally relative to the form as the gap between the slabs opens up. In addition, the diamond plate has increased surface area as compared to dowel

placement systems. The surface area of the diamond plate is also oriented as it is widest where the maximum shear and bearing loads are the greatest (i.e., along the joint) and narrowest where the loads on the diamond plate are at a minimum (i.e., away from the joint).

Unfortunately, the diamond plate dowel system suffers from inherent drawbacks resulting from the relatively sharp interior corners that are formed in one of the slabs by the pocket former. Such sharp interior corner of the slab creates areas of localized stress concentration or stress risers. The sharp interior corners in the concrete frequently result in cracking of the cured concrete due to highly concentrated loads imposed by vehicular traffic such as hard-wheeled forklifts. When cracks initiating at the sharp corners begin propagating outwardly, the diamond plate may bind inside of the pocket former which inhibits movement of the slab in either a lateral or normal direction relative to the joint. If the diamond plate cannot move within the pocket former, then the slab itself may crack at an accelerated rate.

As can be seen, there exists a need in the art for a dowel system capable of minimizing relative vertical displacement of adjacent concrete slabs caused by settling or swelling of the subgrade or by vertical loads that may be imposed by vehicular traffic. Furthermore, there exists a need for a dowel system that may be readily installed within adjacent concrete slabs and which is configured to maintain the slabs in a common plane while allowing both lateral and normal movements of the slabs. Finally, there exists a need for a dowel system that may be installed with a minimum of labor and that does not present a safety hazard during installation of forms and pouring of the concrete slabs.

BRIEF SUMMARY OF THE INVENTION

The present invention specifically addresses and alleviates the above-referenced deficiencies associated with dowel systems of the prior art. More particularly, the present invention is a disc dowel system that is specifically adapted to minimize relative vertical displacement of adjacently disposed concrete slabs while allowing relative horizontal movement thereof. The disc dowel system comprises a dowel plate and corresponding pocket former installed at a pour joint between a first concrete pour and a second concrete pour disposed above a subgrade or a substrate. The disc dowel system may further include a positioner bracket for positioning the pocket former within the first pour.

The dowel plate has a generally rounded shape that is divided into an embed portion and a slidable portion. The slidable portion is configured to be laterally slidable within the pocket former while the embed portion is configured to be substantially encapsulated or embedded within the second pour such that it is rigidly affixed therewithin after the concrete cures or hardens. Advantageously, the dowel plate is provided in a generally rounded shape in order to minimize safety hazards to construction site equipment and personnel who may be injured by contact with an otherwise rough, exposed edge of a dowel plate having sharp corners or a dowel rod having exposed ends. Furthermore, the dowel plate may preferably be shaped such that a width thereof is at a maximum adjacent the pour joint where the bearing, shear and flexural stresses are greatest.

The pocket former has a horizontally-extending interior compartment bounded by a pair of spaced apart, upper and lower former plates defining generally planar, upper and lower inner surfaces. The interior compartment has an open, generally straight side defining a compartment opening. The interior compartment may have an arch-shaped compart-

5

ment perimeter extending from opposing ends of the straight side such that the interior compartment is generally crescent-shaped. The interior compartment is configured with the spacing between the upper and lower former plates being complementary to a thickness of the dowel plate such that a relatively snug, sliding fit is provided therebetween. In this manner, the pocket former creates a void in the first pour such that the dowel plate may be simply slid into the form until a perimeter of the dowel plate is generally in abutment with the compartment perimeter.

The embed portion of the dowel plate is rigidly encapsulated within the second pour and the slidable portion of the dowel plate is slidably disposed within the pocket former such that the dowel plate permits substantially unrestrained relative horizontal movement of the first and second pours in all horizontal directions while restricting relative vertical movement thereof caused by vertical loading. Horizontal movement relative to the pour joint may occur due to uncontrolled shrinkage or contraction of the concrete mixture as water is lost during curing. Vertical loading may be comprised of shear, bearing and flexural loads or any combination thereof caused by settling or swelling of the substrate underlying the first and/or second pours. The vertical loading may also be caused by vehicular or pedestrian traffic passing over the first and second pours.

The disc dowel system may include a positioner bracket that is mounted to a removable concrete form. The positioner bracket facilitates positioning the pocket former during pouring of the first pour. In certain methods of concrete pavement construction, pour joints are typically formed by using a wooden stud or a sheet metal form as the removable concrete form. Such concrete form is typically staked to the substrate along a desired location of the pour joint. The pocket former is positioned adjacent the concrete form such that the interior compartment is substantially horizontally outwardly extending away from the concrete form. Wet concrete is then poured on a side of the concrete form to create the first pour which encapsulates the pocket former. The concrete form is then removed, exposing a pour face of the pour joint along the first pour with the dowel plate opening formed in the pour face. After the slidable portion of the dowel plate is inserted through the dowel plate opening and into the pocket former, the embed portion remains exposed on an opposite side of the pour joint. Wet concrete is then poured on the opposite side of the pour joint to create the second pour which rigidly encapsulates the embed portion of the dowel plate therewithin.

The positioner bracket includes a vertically-disposed base flange and a horizontally disposed plate portion that extends from the base flange. The base flange is rigidly attachable to the concrete form by a variety of means such as with fasteners. The plate portion of the positioner bracket is configured to be complementary to the interior compartment such that the positioner bracket may slidably receive the pocket former with a relatively snug fit. In this manner, the pocket former is held in a generally horizontal orientation during pouring of the first pour and prior to removal of the concrete form and positioner bracket after which the slidable portion of the dowel plate may be inserted into the interior compartment with the subsequent pouring of the second pour to encapsulate the embed portion therewithin.

BRIEF DESCRIPTION OF THE DRAWINGS

These as well as other features of the present invention will become more apparent upon reference to the drawings wherein:

6

FIG. 1 is an exploded perspective view of a disc dowel system of the present invention illustrating a dowel plate and corresponding pocket former;

FIG. 2 is a perspective view illustrating the manner in which a series of pocket formers of the disc dowel systems are used to properly align respective ones of the dowel plates at a pour joint between adjacent first and second concrete pours;

FIG. 3 is an exploded perspective view of the disc dowel system illustrating a positioner bracket mounted on a concrete form with which the disc dowel system is preferably utilized in order to position the pocket former within the first pour;

FIG. 4 is a cross-sectional view illustrating the manner in which the positioner bracket and associated pocket former shown in FIG. 3 are positioned after the first pour is poured; and

FIG. 5 is a cross-sectional view illustrating the manner in which the pocket former and associated dowel plate shown in FIGS. 1 and 2 are positioned after the concrete form and positioner bracket are removed and the second pour is poured.

DETAILED DESCRIPTION OF THE INVENTION

Referring now to the drawings wherein the showings are for purposes of illustrating the present invention and not for purposes of limiting the same, FIG. 1 illustrates a dowel plate **22** and corresponding pocket former **26** of the disc dowel system **10** of the present invention. The disc dowel system **10** is installed at a pour joint **18** between a first concrete pour **14** and a second concrete pour **16** disposed above a subgrade or a substrate **12**, as can be seen in FIG. 5. The substrate **12** may be soil underlying the first and second pours **14**, **16**. Alternatively, the substrate **12** may be a metal decking or other surface that is adapted to support concrete.

As can be seen in FIGS. 1 and 2, the disc dowel system **10** is comprised of the dowel plate **22** and the pocket former **26**. In FIG. 2, a series of the pocket formers **26** are shown encapsulated in the first pour **14** prior to pouring of the second pour **16**. The disc dowel system **10** may further include a positioner bracket **62** for positioning the pocket former **26** within the first pour **14** as is illustrated in FIGS. 3 through 5 and as will be described in greater detail below. As can be seen in FIGS. 1 and 2, the dowel plate **22** has a generally rounded shape that is divided into an embed portion **58** and a slidable portion **60**. The embed portion **58** and the slidable portion **60** may be of substantially equal size and shape. As will be explained in greater detail below, the slidable portion **60** is configured to be laterally slidable within the pocket former **26** while the embed portion **58** is configured to be substantially encapsulated within the second pour **16** such that it is rigidly affixed therewithin after the concrete cures or hardens.

As can be seen in FIG. 1, the dowel plate **22** may advantageously be provided in a generally rounded shape such as in a circular shape in order to minimize safety hazards to construction site equipment and personnel who may otherwise be injured by contact with a rough, exposed edge of a dowel plate having sharp corners or a dowel rod having exposed ends. The dowel plate **22** may also be provided in a generally elliptical shape. Along these lines, it is contemplated that there are a number of alternative shapes of the dowel plate **22** that may be used in the disc dowel system **10** of the present invention. Furthermore, the dowel

plate **22** may preferably be shaped such that a width thereof is at a maximum at a position adjacent the pour joint **18** where the bearing, shear and flexural stresses are the highest. The dowel plate **22** may be shaped such that the width thereof is at a minimum at locations furthest from the pour joint **18** where such stresses are reduced.

In order to facilitate the transfer of vertical loads across the pour joint **18** between the first pour **14** and the second pour **16**, it is contemplated that the dowel plate **22** may be fabricated of a load-bearing material having favorable strength properties. In this regard, the dowel plate **22** may be fabricated from metal plate such as carbon steel plate. A galvanized coating may be included on the dowel plate **22** in order to provide maximum protection of the metal from exposure to concrete which may otherwise result in corrosion for the embed portion **58** of the dowel plate **22**. Other coatings for the metal plate are contemplated and may include powder coating and epoxy coating. In addition, the dowel plate **22** may be fabricated from materials other than metal plate such as fiber glass, carbon fiber, Kevlar, or high density polymeric material such as reinforced plastic.

Referring to FIG. 1, the pocket former **26** has a horizontally-extending interior compartment **42** bounded by a pair of spaced apart, upper and lower former plates **76**, **78** defining generally planar, upper and lower inner surfaces **44**, **46** of the interior compartment **42**. The interior compartment **42** has an open, generally straight side **48** defining a compartment opening **50**. As can be seen in FIGS. 3 and 4, edges of the upper and lower former plates **76**, **78** may be chamfered along the straight side **48** such that leakage of wet concrete between the pocket former **26** and the positioner bracket **62** may be prevented. The interior compartment **42** may have an arch-shaped compartment perimeter **52** extending from opposing ends of the straight side **48** such that the interior compartment **42** is generally crescent-shaped.

However, it is contemplated that the interior compartment **42** may be configured in a variety of alternative shapes with the spacing between the upper and lower former plates **76**, **78** being complementary to a thickness of the dowel plate **22** such that a relatively snug, sliding fit is provided therebetween. For example, it is contemplated that the interior compartment **42** may be rectangularly shaped with the compartment opening **50** being sized to receive the dowel plate **22** therethrough with a minimum gap between edges of the dowel plate **22** and the compartment opening **50**. As is shown in FIG. 2, the compartment opening **50** is preferably aligned with the pour joint **18** at a pour face **20** thereof such that a dowel plate opening **24** is created at the pour face **20**. In this regard, the dowel plate opening **24** is coincident with the compartment opening **50**.

Importantly, the pocket former **26** is configured to create a void in the first pour **14** such that the dowel plate **22** may be simply slid into the form until a perimeter of the dowel plate **22** is substantially in abutment with the compartment perimeter **52**. In this regard, the dowel plate **22** does not penetrate through the pocket former **26** but preferably is configured to snugly fit therewithin. The pocket former **26** may be configured with internal removable spacers (not shown) that separate the upper and lower inner surfaces **44**, **46** during pouring and curing of the first pour **14** such that the former plates **76**, **78** of the pocket former **26** resist flexure. In this manner, a spacing between the upper and lower former plates **76**, **78** is maintained such that the interior compartment **42** will not collapse under the pressure of wet concrete.

As can be seen in FIG. 2, the embed portion **58** of the dowel plate **22** is rigidly encapsulated within the second

pour **16** and the slidable portion **60** of the dowel plate **22** is slidably disposed within the pocket former **26**. In this manner, the dowel plate **22** permits horizontal movement of the first pour **14** relative to the second pour **16** while restricting vertical movement of the first pour **14** relative to the second pour **16**. Advantageously, the relative horizontal movement includes movement in a direction perpendicular, movement in a direction parallel to the pour joint **18** as well as horizontal movement in all ranges between the parallel and perpendicular directions.

Perpendicular movement relative to the pour joint **18** may occur due to uncontrolled shrinkage or contraction of the concrete mixture as water is lost during curing. However, due to the rounded shape of the dowel plate **22** and the complementary configuration of the interior compartment **42** of the pocket former **26**, the disc dowel system **10** of the present invention allows substantially unrestrained relative horizontal movement of the first and second pours **14**, **16** in all horizontal directions. By allowing the first and second pours **14**, **16** to move in horizontal direction along the pour joint **18**, residual stress accumulations may be reduced which may prevent random cracking of the concrete elsewhere.

Referring still to FIG. 2, it can be seen that the disc dowel system **10** (i.e., the pocket former **26** and the dowel plate **22**) may be placed at substantially equal intervals along the pour joint **18**. The dowel plate **22** may be sized to have a predetermined thickness and longitudinal geometry based upon a predicted vertical loading differential between the first and second pours **14**, **16**. Such vertical loading may be comprised of shear, bearing and flexural loads or any combination thereof. As was earlier mentioned, such vertical loading may be caused by settling or swelling of the substrate **12** underlying the first and/or second pours.

The vertical loading may also be caused by vehicular or pedestrian traffic passing over the first and second pours **14**, **16**. In order to transfer such vertical loads across the pour joint **18**, an exemplary dowel plate **22** may be sized with a plate thickness of about one-quarter inch and a maximum width at the pour joint **18** of about six inches. For configuration wherein the dowel plate **22** has a circular shape, the dowel plate **22** has a diameter of about six inches. Typical spacings between disc dowel systems **10** may be about sixteen inches from approximate centers of the installed dowel plates **22** along the pour joint **18** although it is contemplated that the dowel placement system may be installed at any spacing.

Referring briefly now to FIG. 1, the pocket former **26** may include a perimeter flange **34** extending around the pocket former **26** perimeter and attached to the upper and lower former plates **76**, **78**. The perimeter flange **34** may be integrally formed with the former plates **76**, **78** of the pocket former **26** and may have a generally vertically-oriented cross section with dovetailed or flared upper and lower flange portions **36**, **38**. The dovetail or flared configuration of the upper and lower flange portions **36**, **38** facilitates the locking of the pocket former **26** within the first pour **14** preventing horizontal movement after the concrete cures.

Referring still to FIG. 1, the pocket former **26** includes an upper outer surface **28** and a lower outer surface **30**. In order to increase the rigidity or stiffness of the former plates **76**, **78** such that the interior compartment **42** may resist flexion under the pressure of wet concrete in the first pour **14**, each one of the upper and lower outer surfaces **28**, **30** may have a pair of spaced apart, former alignment ribs **40** extending thereacross. The former alignment ribs **40** may be oriented to extend in a direction generally perpendicular to the pour

joint 18 from the straight side 48 to the perimeter flange 34. As can be seen in FIG. 1, the former alignment ribs 40 may be integrally formed with the former plates 76, 78. Each one of the former alignment ribs 40 may have a flared cross section similar in shape to the flared cross section of the upper and lower flange portions 36, 38 of the perimeter flange 34. The flared configuration of the former alignment ribs 40 may aid in locking the pocket former 26 against vertical movement after the concrete cures.

Referring now to FIGS. 3 through 5, the disc dowel system 10 may be configured such that the pocket former 26 may be installed at the pour joint 18 by using the positioner bracket 62 that is mountable to a removable concrete form 56. In certain methods of concrete pavement construction, the removable concrete form 56 is typically comprised of a wooden stud or a sheet metal form. As will be described in greater detail below, such concrete forms 56 are typically staked to the substrate 12 along a desired location of the pour joint 18. The pocket former 26 is positioned adjacent the concrete form 56 such that the interior compartment 42 is substantially horizontally outwardly extending away from the concrete form 56.

Wet concrete is then poured on a side of the concrete form 56 to create the first pour 14 which encapsulates the pocket former 26. The concrete form 56 is then removed, exposing the pour face 20 of the pour joint 18 along the first pour 14 with the dowel plate opening 24 being formed in the pour face 20. After the slidable portion 60 of the dowel plate 22 is inserted through the dowel plate opening 24 and into the pocket former 26, the embed portion 58 remains exposed on an opposite side of the pour joint 18. Wet concrete is then poured on the opposite side of the pour joint 18 to create the second pour 16 which rigidly encapsulates the embed portion 58 of the dowel plate 22 therewithin.

In the disc dowel system 10 of the present invention, the positioner bracket 62 may be mounted on the concrete form 56 to aid in positioning the pocket former 26. In this regard, the positioner bracket 62 is configured to hold the pocket former 26 in a substantially horizontal orientation during pouring and curing of the first pour 14. Referring to FIG. 3, the positioner bracket 62 may include a vertically-disposed base flange 64 and a horizontally disposed plate portion 68 that extends from the base flange 64. The base flange 64 may be formed as a rectangularly-shaped section of plate configured to be rigidly attachable to the concrete form 56. As can be seen, the base flange 64 may be sized such that peripheral edges thereof do not extend beyond top and bottom edges of the concrete form 56.

The base flange 64 may be disposed in abutting contact with the concrete form 56 and may be affixed thereto by a variety of means such as with fasteners. Toward this end, the base flange 64 may include a pair of apertures 66 extending through the base flange 64 at opposing ends, as is shown in FIG. 3. Each one of the apertures 66 may be sized to permit the passage of a fastener through the base flange 64 for facilitating the rigid attachment of the positioner bracket 62 to the concrete form 56. Such fasteners may include wood screws or nails that are driven into the concrete form 56.

As can be seen in FIG. 3, the plate portion 68 of the positioner bracket 62 may be sized and configured to be complementary to the interior compartment 42 such that the positioner bracket 62 may slidably receive the pocket former 26 with a relatively snug fit. The pocket former 26 is extended over the plate portion 68 to a depth whereat the straight side 48 is in generally abutting contact with the base flange 64. In such a position, a perimeter of the plate portion 68 is disposed adjacent to the compartment perimeter 52 of

the pocket former 26. In this manner, the pocket former 26 is held in a generally horizontal orientation during pouring of the first pour 14 and prior to removal of the concrete form 56 and positioner bracket 62 after which the slidable portion 60 of the dowel plate 22 may be inserted into the interior compartment 42 with the subsequent pouring of the second pour 16 to encapsulate the embed portion 58 therewithin.

Referring still to FIG. 3, the plate portion 68 of the positioner bracket 62 includes upper and lower exterior surfaces 70, 72. A pair of spaced apart positioner alignment ribs 74 may be affixed to or formed on respective ones of the upper and lower exterior surfaces 70, 72. The positioner alignment ribs 74 may extend generally perpendicularly from the base flange 64 to the plate portion 68 perimeter. The interior compartment 42 of the pocket former 26 includes upper and lower inner surfaces 44, 46 which may each have a pair of spaced apart alignment grooves 54 formed therein. The alignment grooves 54 may be sized and configured to be complementary to the positioner alignment ribs 74 such that the positioner alignment ribs 74 line up with the alignment grooves 54. The cooperation of the alignment grooves 54 with the positioner alignment ribs 74 facilitates the rigid securement of the pocket former 26 to the positioner bracket 62 during pouring of the first pour 14.

Regarding the material from which the pocket former 26 and positioner bracket 62 may be fabricated, it is contemplated that plastic material may preferably be used. The pocket former 26 and positioner bracket 62 may each be separately injection molded of high density plastic material such as polyethylene plastic in order to impart sufficient strength and stiffness to the pocket former 26 and the positioner bracket 62. Alternatively, it is contemplated that the pocket former 26 and positioner bracket 62 may each be fabricated from materials such as fiber glass and carbon fiber. The former alignment ribs 40, alignment grooves 54 and perimeter flange 34, if included, may also be integrally formed with the pocket former 26 as a unitary structure by way of injection molding. Likewise, the base flange 64, plate portion 68, apertures 66 and positioner alignment ribs 74 may be integrally formed as a unitary structure of the positioner bracket 62 in an injection molding process.

The method of installing the dowel plate 22 within the pour joint 18 using the disc dowel system 10 will now be described with reference to FIGS. 1 through 5. As was earlier mentioned, the dowel plate 22 is installed within the pour joint 18 between adjacent first and second concrete pours 14, 16 as is shown in FIG. 5. As is illustrated in FIG. 2, multiple ones of the disc dowel system 10 of the present invention may be installed along the pour joint 18 in equidistantly spaced relation to each other. The dowel plate 22 may be configured complementary to the pocket former 26. Initially, the disc dowel system 10 is utilized by positioning the concrete form 56 along a desired location of the pour joint 18, as is shown in FIG. 4. The concrete form 56 is typically supported by stakes that are secured to the substrate 12 at spaced intervals along the desired location of the pour joint 18.

If the disc dowel system 10 includes a positioner bracket 62 for facilitating the installation of the pocket former 26 within the first pour 14, the positioner bracket 62 is secured to the concrete form 56 by initially placing the base flange 64 in abutting contact with a side of the concrete form 56. The base flange 64 may be approximately vertically centered on the side of the concrete form 56 such that the plate portion 68 extends substantially horizontally outwardly from the concrete form 56, as can be seen in FIG. 3. Fasteners such as screws or nails may be driven through the apertures 66 of

the base flange 64 and into the concrete form 56 in order to secure the positioner bracket 62 thereto.

After the positioner bracket 62 is secured to the concrete form 56, the pocket former 26 is slidably extended over the positioner bracket 62 until the open straight side 48 of the pocket former 26 is in substantially abutting contact with the base flange 64, as shown in FIG. 4. As was earlier mentioned, edges of the upper and lower former plates 76, 78 may be chamfered such that the upper and lower former plates 76, 78 may be placed in substantially abutting contact with the base flange 64 along the compartment opening 50.

The chamfered edges of the upper and lower former plates 76, 78 may prevent leakage of wet concrete between the pocket former 26 and the positioner bracket 62 which may otherwise hinder the removal of the positioner bracket 62 from the pocket former 26 after the concrete has cured or hardened. If positioner alignment ribs 74 and complementary alignment grooves 54 are included with respective ones of the positioner bracket 62 and the pocket former 26 as is illustrated in FIG. 3, the positioner alignment ribs 74 are aligned with the alignment grooves 54 as the pocket former 26 is slidably extended over the positioner bracket 62.

After the pocket former 26 is slidably extended over the positioner bracket 62, the first pour 14 of concrete is made about the pocket former 26 such that the pocket former 26 is rigidly encapsulated therewithin, as shown in FIG. 4. The bond between the concrete of the first pour 14 and the pocket former 26 may be enhanced if the former alignment ribs 40 and the perimeter flange 34 are included with the pocket former 26, as is illustrated in FIG. 1.

Subsequent to curing and hardening of the first pour 14 of concrete, the concrete form 56 is stripped away from the first pour 14, exposing the pour face 20 of the pour joint 18. The stripping away of the concrete form 56 also causes the positioner bracket 62 to be removed from within the pocket former 26. The positioner bracket 62 remains in rigid attachment to the concrete form 56. Separating the positioner bracket 62 from the concrete form 56 may allow multiple uses of the positioner bracket 62. Removal of the concrete form 56 exposes the dowel plate opening 24 in the pour face 20 of the pour joint 18, as may be seen in FIG. 2.

After the concrete form 56 and the positioner bracket 62 are removed and the concrete has cured and hardened, the slidable portion 60 of the dowel plate 22 may be inserted through the dowel plate openings and into the interior compartment 42 of the pocket former 26 leaving the embed portion 58 exposed on an opposite side of the pour joint 18. The dowel plate 22 may be sized and configured to be complementary to the interior compartment 42 such that a relatively snug, sliding fit is provided between the dowel plate 22 and the pocket former 26. In this manner, vertical play or looseness between the dowel plate 22 and the interior compartment 42 may be minimized such that vertical loads may be effectively transferred across the pour joint 18 between the first and second pours 14, 16 in order to maintain a common plane therebetween.

After the dowel plate 22 is inserted into the pocket former 26, the second pour 16 of concrete is made such that the embed portion 58 of the dowel plate 22 is rigidly encapsulated therewithin with the slidable portion 60 being slidably disposed within the pocket former 26. Due to the snug fit between the dowel plate 22 and the pocket former 26, the concrete of the second pour 16 is prevented from seeping into the interior compartment 42 of the pocket former 26 which may otherwise cause the dowel plate 22 to bond to the pocket former 26.

Additional modifications and improvements of the present invention may also be apparent to those of ordinary skill in the art. Thus, the particular combination of parts described and illustrated herein is intended to represent only certain embodiments of the present invention, and is not intended to serve as limitations of alternative devices within the spirit and scope of the invention.

What is claimed is:

1. A pocket former for a disc dowel system adapted to minimize relative vertical displacement of adjacently disposed concrete slabs, the pocket former comprising:

an interior compartment having at least one horizontally oriented outer surface with at least one former alignment rib being formed on the outer surface such that the former alignment rib is disposed on an exterior of the pocket former so that the former alignment rib supports the outer surface;

wherein:

the pocket former is adapted to be encapsulated within one of the adjacently disposed concrete slabs, and the pocket former being sized and configured to receive a dowel plate having a slidable portion and an embedded portion, the slidable portion being configured to be laterally slidable within the interior compartment and the embedded portion being configured to be encapsulated within the other one of the adjacently disposed concrete slabs; the interior compartment has an open, generally straight side and a taper-shaped compartment perimeter extending therefrom, the straight side being configured to slidably receive the slidable portion into the interior compartment, and the dowel plate being tapered complementary to the taper-shaped compartment perimeter;

a perimeter flange extending around the compartment perimeter and having a generally vertically-oriented cross section with flared upper and lower flange portions.

2. The pocket former of claim 1 having upper and lower outer surfaces, at least one of the upper and lower outer surfaces has a parallel, spaced pair of the former alignment ribs formed thereon to support the outer surfaces.

3. The pocket former of claim 1 wherein the former alignment rib has a flared cross section.

4. The pocket former of claim 1 wherein the former alignment rib has a dovetail shaped cross section.

5. The pocket former of claim 1 wherein at least one of the upper and lower flange portions of the perimeter flange has a dovetail configuration.

6. The pocket former of claim 1 wherein the former alignment rib is oriented perpendicularly relative to the straight side.

7. The pocket former of claim 1 wherein the former alignment rib is configured to resist flexion of the pocket former under pressure of wet concrete.

8. The pocket former of claim 1 wherein the adjacently disposed concrete slabs are formed upon a substrate comprised of at least one of the following: soil and metal decking.

9. A dowel plate for a disc dowel system adapted to minimize relative vertical displacement of adjacently disposed concrete slabs, the dowel plate comprising:

a slidable portion and an embedded portion;

wherein:

the slidable portion is configured to be laterally slidable within a pocket former having horizontally oriented upper and lower outer surfaces, at least one of the upper

13

and lower outer surfaces having a former alignment rib formed thereon such that the former alignment rib is disposed on an exterior of the pocket former so that the former alignment rib supports the outer surfaces; the embedded portion being configured to be encapsulated within one of the adjacently disposed concrete slabs. 5

10. The dowel plate of claim 9 wherein: the pocket former has an interior compartment having an open, generally straight side and a taper-shaped compartment perimeter; the interior compartment being configured to slidably receive the slidable portion; the dowel plate being tapered complementary to the taper-shaped compartment perimeter.

11. The pocket former of claim 9 wherein the dowel plate is fabricated from metal plate. 15

12. The pocket former of claim 9 wherein the dowel plate is fabricated from carbon fiber.

13. A positioner bracket for installing a pocket former of a disc dowel system within a pour joint located between adjacent first and second concrete pours, the pour joint being formable by a concrete form, the pocket former including an interior compartment having at least one groove formed therein, the positioner bracket comprising: 20

- a base flange; and
- a plate portion extending outwardly from the base flange and including upper and lower exterior surfaces and at least one positioner alignment rib formed on at least one of the exterior surfaces, the base flange being configured to be attachable to the concrete form; 25

wherein:

- the plate portion is sized and configured to be complementary to the pocket former;
- the groove being sized and configured to receive the positioner alignment rib such that the pocket former is held in alignment with the positioner bracket. 30

14. The positioner bracket of claim 13 including a parallel, spaced pair of the positioner alignment ribs formed on each of the upper and lower exterior surfaces; 35

14

wherein:

- the interior compartment includes a corresponding number of grooves for receiving the positioner alignment ribs.

15. The positioner bracket of claim 13 wherein the positioner alignment rib is oriented perpendicularly relative to the base flange.

16. A positioner bracket for installing a pocket former of a disc dowel system within a pour joint located between adjacent first and second concrete pours, the pour joint being formable by a concrete form, the positioner bracket comprising: 10

- a base flange; and
- a plate portion extending outwardly from the base flange and including upper and lower exterior surfaces and at least one positioner alignment rib formed on at least one of the exterior surfaces, the base flange being configured to be attachable to the concrete form; 15

wherein:

- the plate portion is sized and configured to be complementary to the pocket former;
- the pocket former including an interior compartment having at least one groove formed therein;
- the groove being sized and configured to receive the positioner alignment rib such that the pocket former is held in alignment with the positioner bracket;
- the pocket former further including an open, generally straight side and a compartment perimeter extending therefrom with a perimeter flange extending around the compartment perimeter, the perimeter flange having a generally vertically-oriented cross section with upper and lower flange portions. 20

* * * * *