



US007367976B2

(12) **United States Patent**
Lawes et al.

(10) **Patent No.:** **US 7,367,976 B2**
(45) **Date of Patent:** **May 6, 2008**

(54) **BIPOLAR FORCEPS HAVING MONOPOLAR EXTENSION**

2,176,479 A 10/1939 Willis

(75) Inventors: **Kate Lawes**, Lafayette, CO (US); **Sean T. Dycus**, Denver, CO (US); **Ned Cosgriff**, Denver, CO (US)

(Continued)

FOREIGN PATENT DOCUMENTS

(73) Assignee: **Sherwood Services AG**, Schaffhausen (CH)

CA 2104423 2/1994

(Continued)

(*) Notice: Subject to any disclaimer, the term of this patent is extended or adjusted under 35 U.S.C. 154(b) by 377 days.

OTHER PUBLICATIONS

(21) Appl. No.: **10/988,950**

Sigel et al. "The Mechanism of Blood Vessel Closure by High Frequency Electrocoagulation" *Surgery Gynecology & Obstetrics*, Oct. 1965 pp. 823-831.

(22) Filed: **Nov. 15, 2004**

(Continued)

(65) **Prior Publication Data**
US 2005/0137590 A1 Jun. 23, 2005

Primary Examiner—Michael Peffley
Assistant Examiner—Victoria W Chen

Related U.S. Application Data

(57) **ABSTRACT**

(60) Provisional application No. 60/520,579, filed on Nov. 17, 2003.

(51) **Int. Cl.**
A61B 18/18 (2006.01)

(52) **U.S. Cl.** **606/51**; 606/45; 606/52; 606/48; 606/41

(58) **Field of Classification Search** 606/41, 606/45, 48-52, 42, 1
See application file for complete search history.

An endoscopic forceps for treating tissue includes a housing having a shaft affixed thereto which has first and second jaw members attached to a distal end thereof. The forceps also includes an actuator for moving jaw members relative to one another from a first position wherein the jaw members are disposed in spaced relation relative to one another to a second position wherein the jaw members cooperate to grasp tissue therebetween. Each of the jaw members is connected to a source of electrosurgical energy such that the jaw members are selectively capable of operating in a bipolar mode which enables the jaw members to conduct bipolar energy through tissue held therebetween to treat tissue. The forceps also includes a monopolar element housed within the first jaw member which is selectively movable from a first position within the first jaw member to a second position distal to the first jaw member. The monopolar element is connected to the source of electrosurgical energy and is selectively activateable independent of the bipolar mode.

(56) **References Cited**
U.S. PATENT DOCUMENTS

- 371,664 A 10/1887 Brannan et al.
- 702,472 A 6/1902 Pignolet
- 728,883 A 5/1903 Downes
- 1,586,645 A 6/1926 Bierman
- 2,002,594 A 5/1935 Wappler et al.
- 2,011,169 A 8/1935 Wappler
- 2,031,682 A 2/1936 Wappler et al.

13 Claims, 8 Drawing Sheets

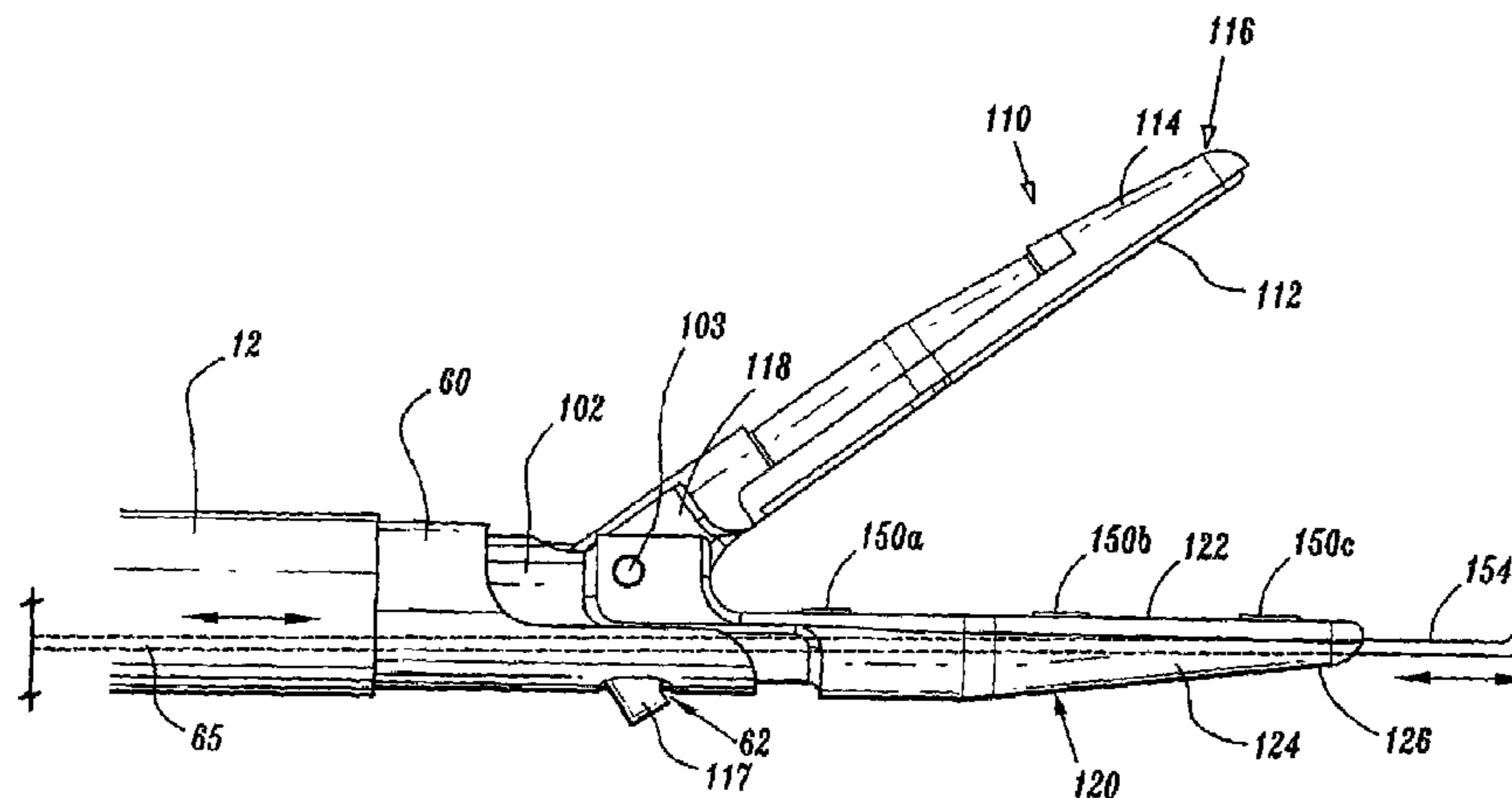

U.S. PATENT DOCUMENTS					
			5,308,357 A	5/1994	Lichtman
			5,318,589 A	6/1994	Lichtman
2,305,156 A	12/1942	Grubel	5,324,289 A	6/1994	Eggers
2,632,661 A	3/1953	Cristofv	5,330,471 A	7/1994	Eggers
2,668,538 A	2/1954	Baker	5,334,183 A	8/1994	Wuchinich
2,796,065 A	6/1957	Kapp	5,334,215 A	8/1994	Chen
3,459,187 A	8/1969	Pallotta	5,336,221 A	8/1994	Anderson
3,643,663 A	2/1972	Sutter	5,342,359 A	8/1994	Rydell
3,651,811 A	3/1972	Hildebrandt et al.	5,342,381 A	8/1994	Tidemand
3,862,630 A	1/1975	Balamuth	5,342,393 A	8/1994	Stack
3,866,610 A	2/1975	Kletschka	5,352,222 A	10/1994	Rydell
3,911,766 A	10/1975	Fridolph et al.	5,354,271 A	10/1994	Voda
3,920,021 A	11/1975	Hiltebrandt	5,356,408 A	10/1994	Rydell
3,921,641 A	11/1975	Hulka	5,366,477 A	11/1994	LeMarie, III et al.
3,938,527 A	2/1976	Rioux et al.	5,368,600 A	11/1994	Failla et al.
3,952,749 A	4/1976	Fridolph et al.	5,383,897 A	1/1995	Wholey
3,970,088 A	7/1976	Morrison	5,389,098 A	2/1995	Tsuruta et al.
3,987,795 A	10/1976	Morrison	5,389,104 A	2/1995	Hahnen et al.
4,005,714 A	2/1977	Hiltebrandt	5,391,166 A	2/1995	Eggers
4,041,952 A	8/1977	Morrison, Jr. et al.	5,391,183 A	2/1995	Janzen et al.
4,043,342 A	8/1977	Morrison, Jr.	5,396,900 A	3/1995	Slater et al.
4,074,718 A	2/1978	Morrison, Jr.	5,403,312 A	4/1995	Yates et al.
4,088,134 A	5/1978	Mazzariello	5,411,519 A	5/1995	Tovey et al.
4,112,950 A	9/1978	Pike	5,411,520 A	5/1995	Nash et al.
4,127,222 A	11/1978	Adams	5,413,571 A	5/1995	Katsaros et al.
4,128,099 A	12/1978	Bauer	5,415,657 A	5/1995	Taymor-Luria
4,165,746 A	8/1979	Burgin	5,422,567 A	6/1995	Matsunaga
4,300,564 A	11/1981	Furihata	5,423,810 A	6/1995	Goble et al.
4,370,980 A	2/1983	Lottick	5,425,739 A	6/1995	Jessen
4,416,276 A	11/1983	Newton et al.	5,429,616 A	7/1995	Schaffer
4,452,246 A	6/1984	Bader et al.	5,431,674 A	7/1995	Basile et al.
4,492,231 A	1/1985	Auth	5,437,292 A	8/1995	Kipshidze et al.
4,552,143 A	11/1985	Lottick	5,438,302 A	8/1995	Goble
4,574,804 A	3/1986	Kurwa	5,441,517 A	8/1995	Kensey et al.
4,597,379 A	7/1986	Kihn et al.	5,443,463 A	8/1995	Stern et al.
4,600,007 A	7/1986	Lahodny et al.	5,443,464 A	8/1995	Russell et al.
4,655,216 A	4/1987	Tischer	5,443,480 A	8/1995	Jacobs et al.
4,657,016 A	4/1987	Garito et al.	5,445,638 A	8/1995	Rydell et al.
4,662,372 A	5/1987	Sharkany et al.	5,445,658 A	8/1995	Durffield et al.
4,671,274 A	6/1987	Sorochenko	5,451,224 A	9/1995	Goble et al.
4,685,459 A	8/1987	Koch et al.	5,456,684 A	10/1995	Schmidt et al.
D295,893 S	5/1988	Sharkany et al.	5,458,598 A	10/1995	Feinberg et al.
D295,894 S	5/1988	Sharkany et al.	5,460,629 A	10/1995	Shlain et al.
4,763,669 A	8/1988	Jaeger	5,462,546 A	10/1995	Rydell
4,827,929 A	5/1989	Hodge	5,472,443 A	12/1995	Cordis et al.
4,887,612 A	12/1989	Esser et al.	5,478,351 A	12/1995	Meade et al.
4,938,761 A	7/1990	Ensslin	5,480,409 A	1/1996	Riza
4,985,030 A	1/1991	Melzer et al.	5,484,436 A	1/1996	Eggers et al.
5,007,908 A	4/1991	Rydell	5,496,317 A	3/1996	Goble et al.
5,026,370 A	6/1991	Lottick	5,496,347 A	3/1996	Hashiguchi et al.
5,084,057 A	1/1992	Green et al.	5,499,997 A	3/1996	Sharpe et al.
5,099,840 A	3/1992	Goble et al.	5,509,922 A	4/1996	Aranyi et al.
5,116,332 A	5/1992	Lottick	5,514,134 A	5/1996	Rydell et al.
5,147,357 A	9/1992	Rose et al.	5,527,313 A	6/1996	Scott et al.
5,151,102 A	9/1992	Kamiyama et al.	5,531,744 A	7/1996	Nardella et al.
5,176,695 A	1/1993	Dulebohn	5,536,251 A	7/1996	Evard et al.
5,190,541 A	3/1993	Abele et al.	5,540,684 A	7/1996	Hassler, Jr.
5,196,009 A	3/1993	Kirwan, Jr.	5,540,685 A	7/1996	Parins et al.
5,197,964 A	3/1993	Parins	5,540,715 A	7/1996	Katsaros et al.
5,215,101 A	6/1993	Jacobs et al.	5,542,945 A	8/1996	Fritsch
5,217,457 A	6/1993	Delahuerga et al.	5,558,672 A	9/1996	Edwards et al.
5,217,458 A	6/1993	Parins	5,562,699 A	10/1996	Heimberger et al.
5,217,460 A	6/1993	Knoepfler	5,569,241 A	10/1996	Edwardds
5,219,354 A	6/1993	Choudhury et al.	5,569,243 A	10/1996	Kortenbach et al.
5,244,462 A	9/1993	Delahuerga et al.	5,571,100 A	11/1996	Goble et al.
5,250,047 A	10/1993	Rydell	5,573,424 A	11/1996	Poppe
5,258,006 A	11/1993	Rydell et al.	5,573,534 A	11/1996	Stone
5,261,918 A	11/1993	Phillips et al.	5,573,535 A *	11/1996	Viklund 606/51
5,275,615 A	1/1994	Rose	5,578,052 A	11/1996	Koros et al.
5,277,201 A	1/1994	Stern	5,582,611 A	12/1996	Tsukagoshi et al.
5,282,799 A	2/1994	Rydell	5,585,896 A	12/1996	Yamazaki et al.
5,290,286 A	3/1994	Parins	5,590,570 A	1/1997	LeMaire, III et al.
5,304,203 A	4/1994	El-Mallawany et al.	5,601,601 A	2/1997	Tal et al.

US 7,367,976 B2

5,603,711 A	2/1997	Parins et al.	5,944,718 A	8/1999	Dafforn et al.
5,603,723 A	2/1997	Aranyi et al.	5,951,549 A	9/1999	Richardson et al.
5,611,798 A	3/1997	Eggers	5,954,720 A	9/1999	Wilson et al.
5,626,578 A	5/1997	Tihon	5,957,923 A	9/1999	Hahnen et al.
5,626,609 A	5/1997	Zvenyatsky et al.	5,961,514 A	10/1999	Long et al.
5,630,833 A	5/1997	Katsaros et al.	5,976,132 A	11/1999	Morris
5,637,110 A	6/1997	Pennybacker et al.	5,984,939 A	11/1999	Yoon
5,643,294 A	7/1997	Tovey et al.	5,989,277 A	11/1999	LeMaire, III et al.
5,647,869 A	7/1997	Goble et al.	6,004,335 A	12/1999	Vaitekunas et al.
5,647,871 A	7/1997	Levine et al.	6,010,516 A	1/2000	Hulka et al.
5,649,959 A	7/1997	Hannam et al.	6,024,741 A	2/2000	Willaimson et al.
5,658,281 A	8/1997	Heard	6,024,744 A	2/2000	Kese et al.
5,662,667 A	9/1997	Knodel	6,030,384 A	2/2000	Nezhat
5,665,100 A	9/1997	Yoon	6,033,399 A	3/2000	Gines
5,667,526 A	9/1997	Levin	6,039,733 A	3/2000	Buysse et al.
5,674,220 A	10/1997	Fox et al.	6,041,679 A	3/2000	Slater et al.
5,681,282 A	10/1997	Eggers et al.	6,050,996 A	4/2000	Schmaltz et al.
5,693,051 A	12/1997	Schulze et al.	6,053,914 A	4/2000	Eggers et al.
5,695,522 A	12/1997	LeMaire, III et al.	6,053,933 A	4/2000	Balazs et al.
5,700,261 A	12/1997	Brinkerhoff	D424,694 S	5/2000	Tetzlaff et al.
5,702,390 A	12/1997	Austin et al.	D425,201 S	5/2000	Tetzlaff et al.
5,707,369 A	1/1998	Vaitekunas et al.	6,059,782 A	5/2000	Novak et al.
5,709,680 A	1/1998	Yates et al.	RE36,795 E	7/2000	Rydell
5,716,366 A	2/1998	Yates	6,083,223 A	7/2000	Baker
5,720,744 A	2/1998	Eggleston et al.	6,086,586 A *	7/2000	Hooven 606/50
5,727,428 A	3/1998	LeMaire, III et al.	6,090,107 A	7/2000	Borgmeier et al.
5,735,848 A	4/1998	Yates et al.	6,096,037 A	8/2000	Mulier et al.
5,743,906 A	4/1998	Parins et al.	6,099,550 A	8/2000	Yoon
5,755,717 A	5/1998	Yates et al.	6,102,909 A	8/2000	Chen et al.
5,766,130 A	6/1998	Selmonosky	6,110,171 A	8/2000	Rydell
5,766,166 A	6/1998	Hooven	6,113,596 A	9/2000	Hooven et al.
5,766,170 A	6/1998	Eggers	6,113,598 A	9/2000	Baker
5,769,849 A	6/1998	Eggers	6,117,158 A	9/2000	Measamer et al.
5,772,655 A	6/1998	Bauer et al.	6,123,701 A	9/2000	Nezhat
5,772,670 A	6/1998	Brosa	H1904 H	10/2000	Yates et al.
5,776,128 A	7/1998	Eggers	6,126,658 A	10/2000	Baker
5,776,130 A	7/1998	Buysse et al.	6,152,923 A	11/2000	Ryan
5,779,701 A	7/1998	McBrayer et al.	6,162,220 A	12/2000	Nezhat
5,792,137 A	8/1998	Carr et al.	6,174,309 B1	1/2001	Wrublewski et al.
5,792,177 A	8/1998	Kaseda	6,179,834 B1	1/2001	Buysse et al.
5,797,927 A	8/1998	Yoon	6,179,837 B1	1/2001	Hooven
5,797,938 A	8/1998	Paraschac et al.	6,183,467 B1	2/2001	Shapeton et al.
5,797,958 A	8/1998	Yoon	6,187,003 B1	2/2001	Buysse et al.
5,800,449 A	9/1998	Wales	6,190,386 B1 *	2/2001	Rydell 606/51
5,807,393 A	9/1998	Williamson, IV et al.	6,193,718 B1	2/2001	Kortenbach et al.
5,810,808 A	9/1998	Eggers	6,206,876 B1	3/2001	Levine et al.
5,810,811 A	9/1998	Yates et al.	6,206,877 B1	3/2001	Kese et al.
5,810,877 A	9/1998	Roth et al.	6,217,602 B1	4/2001	Redmon
5,814,043 A	9/1998	Shapeton	6,221,039 B1	4/2001	Durgin et al.
5,817,083 A	10/1998	Shemesh et al.	6,224,593 B1	5/2001	Ryan et al.
5,820,630 A	10/1998	Lind	6,228,080 B1	5/2001	Gines
5,827,271 A	10/1998	Buysse et al.	6,228,083 B1	5/2001	Lands et al.
5,827,279 A	10/1998	Hughett et al.	6,267,761 B1	7/2001	Ryan
5,827,281 A	10/1998	Levin	6,270,497 B1	8/2001	Sekino et al.
5,833,690 A	11/1998	Yates et al.	6,270,508 B1	8/2001	Klieman et al.
5,843,080 A	12/1998	Fleenor et al.	6,273,887 B1	8/2001	Yamauchi et al.
5,849,022 A	12/1998	Sakashita et al.	6,277,117 B1	8/2001	Tetzlaff et al.
5,853,412 A	12/1998	Mayenberger	6,280,458 B1	8/2001	Boche et al.
5,860,976 A	1/1999	Billings et al.	6,283,961 B1	9/2001	Underwood et al.
5,876,401 A	3/1999	Schulze et al.	D449,886 S	10/2001	Tetzlaff et al.
5,891,141 A	4/1999	Rydell	6,322,561 B1	11/2001	Eggers et al.
5,891,142 A	4/1999	Eggers et al.	6,334,860 B1	1/2002	Dorn
5,893,863 A	4/1999	Yoon	6,334,861 B1	1/2002	Chandler et al.
5,893,875 A	4/1999	O'Connor et al.	6,345,532 B1	2/2002	Coudray et al.
5,893,877 A	4/1999	Gampp, Jr. et al.	6,350,264 B1	2/2002	Hooven
5,902,301 A	5/1999	Olig	6,352,536 B1	3/2002	Buysse et al.
5,906,630 A	5/1999	Anderhub et al.	6,358,249 B1	3/2002	Chen et al.
5,908,420 A	6/1999	Parins et al.	D457,958 S	5/2002	Dycus et al.
5,911,719 A	6/1999	Eggers	D457,959 S	5/2002	Tetzlaff et al.
5,913,874 A	6/1999	Berns et al.	6,387,094 B1	5/2002	Eitenmuller
5,921,984 A	7/1999	Sutcu et al.	6,398,779 B1	6/2002	Buysse et al.
5,925,043 A	7/1999	Kumar et al.	6,402,747 B1	6/2002	Lindemann et al.
5,935,126 A	8/1999	Riza	6,409,728 B1	6/2002	Ehr et al.

US 7,367,976 B2

H2037 H	7/2002	Yates et al.	7,156,846 B2	1/2007	Dycus et al.
6,419,675 B1	7/2002	Gallo, Sr.	7,160,298 B2	1/2007	Lawes et al.
6,425,896 B1	7/2002	Baltschun et al.	7,160,299 B2	1/2007	Baily
6,440,144 B1	8/2002	Bacher	7,169,146 B2	1/2007	Truckai et al.
6,443,952 B1	9/2002	Mulier et al.	7,179,258 B2	2/2007	Buysse et al.
6,443,970 B1	9/2002	Schulze et al.	7,195,631 B2	3/2007	Dumbauld
6,451,018 B1	9/2002	Lands et al.	D541,418 S	4/2007	Schechter et al.
6,458,128 B1	10/2002	Schulze	7,207,990 B2	4/2007	Lands et al.
6,458,130 B1	10/2002	Frazier et al.	D541,938 S	5/2007	Kerr et al.
6,464,701 B1	10/2002	Hooven et al.	7,223,265 B2	5/2007	Keppel
6,464,702 B2	10/2002	Schulze et al.	7,232,440 B2*	6/2007	Dumbauld et al. 606/51
6,464,704 B2	10/2002	Schmaltz et al.	7,241,296 B2	7/2007	Buysse et al.
6,500,176 B1*	12/2002	Truckai et al. 606/51	7,252,667 B2	8/2007	Moses et al.
6,511,480 B1	1/2003	Tetzlaff et al.	7,255,697 B2	8/2007	Dycus et al.
6,514,252 B2*	2/2003	Nezhat et al. 606/48	7,267,677 B2	9/2007	Johnson et al.
6,527,771 B1	3/2003	Weadock et al.	7,270,660 B2	9/2007	Ryan
6,558,385 B1*	5/2003	McClurken et al. 606/50	7,270,664 B2	9/2007	Johnson et al.
6,585,735 B1	7/2003	Frazier et al.	2002/0013583 A1	1/2002	Camran et al.
6,616,661 B2*	9/2003	Wellman et al. 606/50	2002/0049442 A1	4/2002	Roberts et al.
6,620,161 B2	9/2003	Schulze et al.	2002/0099372 A1	7/2002	Schulze et al.
6,626,901 B1	9/2003	Treat et al.	2002/0107517 A1	8/2002	Witt et al.
6,641,595 B1	11/2003	Moran et al.	2002/0111624 A1	8/2002	Witt et al.
6,652,521 B2	11/2003	Schulze	2002/0188294 A1	12/2002	Couture et al.
6,656,177 B2	12/2003	Truckai et al.	2003/0014052 A1	1/2003	Buysse et al.
6,669,696 B2	12/2003	Bacher et al.	2003/0014053 A1	1/2003	Nguyen et al.
6,679,882 B1*	1/2004	Kornerup 606/51	2003/0018331 A1	1/2003	Dycus et al.
6,682,528 B2	1/2004	Frazier et al.	2003/0018332 A1	1/2003	Schmaltz et al.
6,685,724 B1	2/2004	Haluck	2003/0032956 A1	2/2003	Lands et al.
6,695,840 B2	2/2004	Schulze	2003/0069571 A1	4/2003	Treat et al.
6,702,810 B2	3/2004	McClurken et al.	2003/0078578 A1	4/2003	Truckai Csaba et al.
6,726,088 B2	4/2004	Waldburger et al.	2003/0109875 A1	6/2003	Tetzlaff et al.
6,726,686 B2	4/2004	Buysse et al.	2003/0114851 A1	6/2003	Truckai et al.
6,733,498 B2	5/2004	Paton et al.	2003/0139741 A1	7/2003	Goble et al.
6,743,229 B2	6/2004	Buysse et al.	2003/0139742 A1	7/2003	Wampler et al.
6,770,072 B1	8/2004	Truckai et al.	2003/0158549 A1	8/2003	Swanson
6,773,434 B2	8/2004	Ciarrocca	2003/0181910 A1	9/2003	Dycus et al.
6,776,780 B2	8/2004	Mulier et al.	2003/0199869 A1	10/2003	Johnson et al.
6,790,217 B2	9/2004	Schulze et al.	2003/0216732 A1	11/2003	Truckai et al.
D496,997 S	10/2004	Dycus et al.	2003/0220637 A1	11/2003	Csaba Truckai et al.
6,802,843 B2	10/2004	Truckai et al.	2003/0229344 A1*	12/2003	Dycus et al. 606/51
D499,181 S	11/2004	Dycus et al.	2003/0236325 A1	12/2003	Bonora
6,818,000 B2	11/2004	Muller et al.	2004/0030330 A1	2/2004	Brassell et al.
6,887,240 B1	5/2005	Lands et al.	2004/0030332 A1	2/2004	Knowlton et al.
6,926,716 B2	8/2005	Baker et al.	2004/0049185 A1	3/2004	Latterell et al.
6,929,644 B2	8/2005	Truckai et al.	2004/0064151 A1	4/2004	Mollenauer
6,932,810 B2	8/2005	Ryan	2004/0082952 A1	4/2004	Dycus et al.
6,932,816 B2	8/2005	Phan	2004/0087943 A1	5/2004	Dycus et al.
6,942,662 B2	9/2005	Goble et al.	2004/0115296 A1	6/2004	Duffin
6,960,210 B2	11/2005	Lands et al.	2004/0116924 A1	6/2004	Dycus et al.
6,964,662 B2	11/2005	Kidooka	2004/0116979 A1	6/2004	Truckai et al.
6,994,707 B2	2/2006	Ellman et al.	2004/0122423 A1	6/2004	Dycus et al.
7,011,657 B2	3/2006	Truckai et al.	2004/0143263 A1	7/2004	Schechter et al.
7,033,354 B2	4/2006	Keppel	2004/0147925 A1	7/2004	Buysse et al.
7,052,496 B2	5/2006	Yamauchi	2004/0162557 A1	8/2004	Tetzlaff et al.
D525,361 S	7/2006	Hushka	2004/0176762 A1	9/2004	Lawes et al.
7,083,618 B2	8/2006	Couture et al.	2004/0225288 A1	11/2004	Buysse et al.
7,090,673 B2	8/2006	Dycus et al.	2004/0230189 A1	11/2004	Keppel
7,101,371 B2	9/2006	Dycus et al.	2004/0236325 A1	11/2004	Tetzlaff et al.
7,101,372 B2	9/2006	Dycus et al.	2004/0243125 A1	12/2004	Dycus et al.
7,101,373 B2	9/2006	Dycus et al.	2004/0249371 A1	12/2004	Dycus et al.
7,103,947 B2	9/2006	Sartor et al.	2004/0249374 A1	12/2004	Tetzlaff et al.
7,112,199 B2	9/2006	Cosmescu	2004/0250419 A1	12/2004	Sremcich et al.
D531,311 S	10/2006	Guerra et al.	2004/0254573 A1	12/2004	Dycus et al.
7,118,570 B2	10/2006	Tetzlaff et al.	2005/0004564 A1	1/2005	Wham et al.
7,118,587 B2	10/2006	Dycus et al.	2005/0004568 A1	1/2005	Lawes et al.
7,131,970 B2	11/2006	Moses et al.	2005/0004570 A1	1/2005	Chapman et al.
7,131,971 B2	11/2006	Dycus et al.	2005/0021025 A1	1/2005	Buysse et al.
7,135,020 B2	11/2006	Lawes et al.	2005/0021026 A1	1/2005	Baily
D533,942 S	12/2006	Kerr et al.	2005/0021027 A1	1/2005	Shields et al.
7,147,638 B2	12/2006	Chapman et al.	2005/0033278 A1	2/2005	McClurken et al.
7,150,097 B2	12/2006	Sremcich et al.	2005/0096645 A1*	5/2005	Wellman et al. 606/41
7,150,749 B2	12/2006	Dycus et al.	2005/0101951 A1	5/2005	Wham et al.
D535,027 S	1/2007	James et al.	2005/0101952 A1	5/2005	Lands et al.

2005/0107784	A1	5/2005	Moses et al.	EP	0650701	A1	5/1995
2005/0107785	A1	5/2005	Dycus et al.	EP	0694290	A3	3/1996
2005/0113818	A1	5/2005	Sartor et al.	EP	0717966	A1	6/1996
2005/0113819	A1	5/2005	Wham et al.	EP	0754437	A3	3/1997
2005/0113826	A1	5/2005	Johnson et al.	EP	0853922	A1	7/1998
2005/0113827	A1*	5/2005	Dumbauld et al. 606/45	EP	0875209	A1	11/1998
2005/0113828	A1	5/2005	Shields et al.	EP	0878169	A1	11/1998
2005/0119655	A1	6/2005	Moses et al.	EP	0887046	A3	1/1999
2005/0137590	A1*	6/2005	Lawes et al. 606/45	EP	0923907	A1	6/1999
2005/0149151	A1	7/2005	Orszulak et al.	EP	0986990	A1	3/2000
2005/0187547	A1*	8/2005	Sugi 606/48	EP	1034747	A1	9/2000
2006/0064085	A1	3/2006	Schechter et al.	EP	1034748	A1	9/2000
2006/0079891	A1	4/2006	Arts et al.	EP	1025807	A3	10/2000
2006/0126146	A1	6/2006	Dycus et al.	EP	1034746	A3	10/2000
2006/0129146	A1	6/2006	Dycus et al.	EP	1050278	A1	11/2000
2006/0161150	A1	7/2006	Keppel	EP	1053719	A1	11/2000
2006/0167450	A1	7/2006	Johnson et al.	EP	1053720	A1	11/2000
2006/0167452	A1	7/2006	Moses et al.	EP	1055399	A1	11/2000
2006/0173452	A1	8/2006	Buyse et al.	EP	1055400	A1	11/2000
2006/0189980	A1	8/2006	Johnson et al.	EP	1080694	A1	3/2001
2006/0189981	A1	8/2006	Dycus et al.	EP	1082944	A1	3/2001
2006/0190035	A1	8/2006	Hushka et al.	EP	1159926	A2	12/2001
2006/0217709	A1	9/2006	Couture et al.	EP	1301135	A	4/2003
2006/0224158	A1	10/2006	Odom et al.	EP	1330991	A1	7/2003
2006/0259036	A1	11/2006	Tetzlaff et al.	EP	1486177	A2	6/2004
2006/0264922	A1	11/2006	Sartor et al.	EP	1472984	A1	11/2004
2006/0264931	A1	11/2006	Chapman et al.	EP	1530952	A1	5/2005
2006/0271038	A1	11/2006	Johnson et al.	EP	1532932	A1	5/2005
2007/0043352	A1	2/2007	Garrison et al.	EP	1632192	A1	3/2006
2007/0043353	A1	2/2007	Dycus et al.	EP	1645238	A1	4/2006
2007/0055231	A1	3/2007	Dycus et al.	EP	1707143	A1	10/2006
2007/0062017	A1	3/2007	Dycus et al.	GB	2214430	A	6/1989
2007/0074807	A1	4/2007	Guerra	JP	501068		9/1984
2007/0078456	A1	4/2007	Dumbauld et al.	JP	502328		3/1992
2007/0078458	A1	4/2007	Dumbauld et al.	JP	5-40112		2/1993
2007/0078459	A1	4/2007	Johnson et al.	JP	06343644	A2	12/1994
2007/0088356	A1	4/2007	Moses et al.	JP	07265328	A2	10/1995
2007/0106295	A1	5/2007	Garrison et al.	JP	08056955	A2	3/1996
2007/0106297	A1	5/2007	Dumbauld et al.	JP	08252263	A2	10/1996
2007/0118111	A1	5/2007	Weinberg	JP	09010223	A2	1/1997
2007/0118115	A1	5/2007	Artale et al.	JP	11244298	A2	9/1999
2007/0142833	A1	6/2007	Dycus et al.	JP	200342599	A2	12/2000
2007/0142834	A1	6/2007	Dumbauld	JP	2000342599	A2	12/2000
2007/0156139	A1	7/2007	Schechter et al.	JP	2000350732	A2	12/2000
2007/0156140	A1	7/2007	Baily	JP	2001008944	A2	1/2001
2007/0173811	A1	7/2007	Couture et al.	JP	2001029356	A2	2/2001
2007/0173814	A1	7/2007	Hixson et al.	JP	2001128990	A2	5/2001
2007/0179499	A1	8/2007	Garrison	SU	401367		10/1973
2007/0203485	A1	8/2007	Keppel	SU	401367		11/1974
2007/0213706	A1	9/2007	Dumbauld et al.	WO	WO89/00757		1/1989
2007/0213707	A1	9/2007	Dumbauld et al.	WO	WO 92/06642		4/1992
2007/0213708	A1	9/2007	Dumbauld et al.	WO	WO 94/08524	A	4/1994
2007/0213712	A1	9/2007	Buyse et al.	WO	WO98/20025		9/1994

FOREIGN PATENT DOCUMENTS

DE	2415263	10/1975	WO	WO95/07662	3/1995
DE	2627679	1/1977	WO	WO95/15124	6/1995
DE	8712328	3/1988	WO	WO96/05776	2/1996
DE	4303882	8/1994	WO	WO 96/22056	7/1996
DE	29616210	1/1997	WO	WO 96/13218	9/1996
DE	19608716	4/1997	WO	WO 97/00646	1/1997
DE	19608718	4/1997	WO	WO 97/00647	1/1997
DE	19751106	5/1998	WO	WO97/10764	3/1997
DE	19751108	5/1999	WO	WO 97/10764	3/1997
EP	0364216	A1 4/1990	WO	WO 97/24073	7/1997
EP	0518230	A1 12/1992	WO	WO 97/24993	7/1997
EP	0 541 930	B1 5/1993	WO	WO 98/27880	7/1998
EP	0572131	12/1993	WO	WO 99/03407	1/1999
EP	0584787	A1 3/1994	WO	WO 99/03408	1/1999
EP	0589453	A2 3/1994	WO	WO 99/03409	1/1999
EP	0623316	A1 11/1994	WO	WO99/12488	3/1999
EP	0624348	A2 11/1994	WO	WO 99/12488	A 3/1999
			WO	WO 99/40857	8/1999

WO	WO 99/40861	8/1999
WO	WO 99/51158	10/1999
WO	WO 99/66850	12/1999
WO	WO 99/66850 A	12/1999
WO	WO 00/24330	5/2000
WO	WO00/24331	5/2000
WO	WO 00/24331	5/2000
WO	WO 00/41638	7/2000
WO	WO00/47124	8/2000
WO	WO 00/53112	9/2000
WO	WO 01/17448 A	3/2001
WO	WO 01/54604	8/2001
WO	WO02/07627	1/2002
WO	WO 02/07627	1/2002
WO	WO02/080783	10/2002
WO	WO 02/080783	10/2002
WO	WO 02/080784	10/2002
WO	WO02/080784	10/2002
WO	WO 02/080785	10/2002
WO	WO02/080785	10/2002
WO	WO02/080786	10/2002
WO	WO 02/080786	10/2002
WO	WO02/080793	10/2002
WO	WO 02/080793	10/2002
WO	WO02/080794	10/2002
WO	WO 02/080794	10/2002
WO	WO 02/080795	10/2002
WO	WO 02/080796	10/2002
WO	WO 02/080797	10/2002
WO	WO02/080797	10/2002
WO	WO 02/080798	10/2002
WO	WO 02/080798 A1	10/2002
WO	WO 02/080799	10/2002
WO	WO 02/081170	10/2002
WO	WO02/081170	10/2002
WO	WO 03/101311	12/2003
WO	WO2004/032777	4/2004
WO	WO 2004/052221	6/2004
WO	WO 2004/052221 A1	6/2004
WO	WO2004/073490	9/2004
WO	WO 2004/073490	9/2004
WO	WO2004/073753	9/2004
WO	WO 2004/082495	9/2004
WO	WO 2004/082495 A1	9/2004
WO	WO 2004/098383 A1	11/2004
WO	WO 2004/103156	12/2004
WO	WO2005/004735	1/2005
WO	WO 2005/110264	11/2005

OTHER PUBLICATIONS

Bergdahl et al. "Studies on Coagulation and the Development of an Automatic Computerized Bipolar Coagulator" *J. Neurosurg*, vol. 75, Jul. 1991, pp. 148-151.

Kennedy et al. "High-burst-strength, feedback-controlled bipolar vessel sealing" *Surgical Endoscopy* (1998) 12: 876-878.

Peterson et al. "Comparison of Healing Process Following Ligation with Sutures and Bipolar Vessel Sealing" *Surgical Technology International* (2001).

Linehan et al. "A Phase I Study of the LigaSure Vessel Sealing System in Hepatic Surgery" Section of HPB Surger, Washington University School of Medicine, St. Louis MO, Presented at AHPBA, Feb. 2001.

Johnson et al. "Evaluation of the LigaSure Vessel Sealing System in Hemorrhoidectomy" American College of Surgeons (ACS) Clinica Congress Poster (2000).

Sayfan et al. "Sutureless Closed Hemorrhoidectomy: A New Technique" *Annals of Surgery* vol. 234 No. 1 Jul. 2001 pp. 21-24.

Heniford et al. "Initial Results with an Electrothermal Bipolar Vessel Sealer" *Surgical Endoscopy* (2000) 15:799-801.

Heniford et al. "Initial Research and Clinical Results with an Electrothermal Bipolar Vessel Sealer" Oct. 1999.

McLellan et al. "Vessel Sealing for Hemostasis During Pelvic Surgery" Int'l Federation of Gynecology and Obstetrics FIGO World Congress 2000, Washington, D.C.

Levy et al. "Use of a New Energy-based Vessel Ligation Device During Vaginal Hysterectomy" Int'l Federation of Gynecology and Obstetrics (FIGO) World Congress.

Crawford et al. "Use of the LigaSure Vessel Sealing System in Urologic Cancer Surger" *Grand Rounds in Urology* 1999 vol. 1 Issue 4 pp. 10-17.

Rothenberg et al, "Use of the LigaSure Vessel Sealing System in Minimally Invasive Surgery In Children" Int'l Pediatric Endosurgery Group (IPEG) 2000.

Palazzo et al. "Randomized clinical trial of Ligasure versus open haemorrhoidectomy" *British Journal of Surgery* 2002, 89, 154-157. "Innovations in Electrosurgery" Sales/Product Literature.

LigaSure Vessel Sealing System, the Seal of Confidence in General, Gynecologic, Urologic, and Laparoscopic Surgery Sales/Product Literature.

Carbonell et al, "Comparison of theGyrus PlasmaKinetic Sealer and the Valleylab LigaSure Device in the Hemostasis of Small, Medium, and Large-Sized Arteries" Carolinas Laparoscopic and Advanced Surgery Program, Carolinas Medical Center, Charlotte, NC.

"Reducing Needlestick Injuries in the Operating Room" Sales/Product Literature.

Chung et al., "Clinical Experience of Sutureless Closed Hemorrhoidectomy with LigaSure" *Diseases of the Colon & Rectum* vol. 46, No. 1 Jan. 2003.

Strasberg et al., "Use of a Bipolar Vessel-Sealing Device for Parenchymal Transection During Liver Surgery" *Journal of Gastrointestinal Surgery*, vol. 6, No. 4, Jul./Aug. 2002 pp. 569-574.

Paul G. Horgan, "A Novel Technique of Parenchymal Division During Hepatectomy" *The American Journal of Surgery*, vol. 181, No. 3, □Apr. 2001 pp. 236-237.

W. Scott Helton, "LigaSure Vessel Sealing System: Revolutionary Hemostasis Product for General Surgery" Sales/Product Literature.

Michael Choti, "Abdominoperineal Resection with the LigaSure Vessel Sealing System and LigaSure Atlas 20 cm Open Instrument" *Innovations That work*, □Jun. 2003.

Craig Johnson, "Use of the LigaSure Vessel Sealing System in Bloodless Hemorrhoidectomy" *Innovations That Work*, □Mar. 2000.

Muller et al., "Extended Left Hemicolectomy Using the LigaSure Vessel Sealing System" *Innovations That Work*,□Sep. 1999.

Herman et al., "Laparoscopic Intestinal Resection With the LigaSure Vessel Sealing System: A Case Report" *Innovations That Work*,□Feb. 2002.

Carus et al., "Initial Experience With The LigaSure Vessel Sealing System in Abdominal Surgery" *Innovations That Work*,□Jun. 2002.

Levy et al. "Randomized Trial of Suture Versus Electrosurgical Bipolar Vessel Sealing in Vaginal Hysterectomy" *Obstetrics & Gynecology*, vol. 102, No. 1, Jul. 2003.

Levy et al., "Update on Hysterectomy—New Technologies and Techniques" *OBG Management*, Feb. 2003.

Barbara Levy, "Use of a New Vessel Ligation Device During Vaginal Hysterectomy" FIGO 2000, Washington, D.C.

McLellan et al. "Vessel Sealing For Hermostasis During Gynecologic Surgery" Sales/Product Literature.

Sengupta et al., "Use of a Computer-Controlled Bipolar Diathermy System in Radical Prostatectomies and Other Open Urological Surgery" *ANZ Journal of Surgery* (2001) 71.9 pp. 538-540.

Olsson et al. "Radical Cystectomy in Females" *Current Surgical Techniques in Urology*, vol. 14, Issue 3.

E. David Crawford "Use of a Novel Vessel Sealing Technology in Management of the Dorsal Veinous Complex" Sales/Product Literature.

Jarrett et al., "Use of the LigaSure Vessel Sealing System for Peri-Hilar Vessels in Laparoscopic Nephrectomy" Sales/Product Literature.

E. David Crawford "Evaluation of a New Vessel Sealing Device in Urologic Cancer Surgery" Sales/Product Literature.

Joseph Ortenberg "LigaSure System Used in Laparoscopic 1st and 2nd Stage Orchiopexy" *Innovations That Work*, Nov. 2002.

- Koyle et al., "Laparoscopic Palomo Varicocele Ligation in Children and Adolescents" *Pediatric Endosurgery & Innovative Techniques*, vol. 6, No. 1, 2002.
- Dulemba et al. "Use of a Bipolar Electrothermal Vessel Sealer in Laparoscopically Assisted Vaginal Hysterectomy" *Sales/Product Literature*.
- Johnson et al. "Evaluation of a Bipolar electrothermal Vessel Sealing Device in Hemorrhoidectomy" *Sales/Product Literature*.
- Int'l Search Report PCT/US01/11218.
- Int'l Search Report PCT/US99/24869.
- Int'l Search Report PCT/US98/18640.
- Int'l Search Report PCT/US98/23950.
- Int'l Search Report PCT/US04/13273.
- Int'l Search Report PCT/US04/15311.
- Int'l Search Report PCT/US01/11420.
- Int'l Search Report PCT/US02/11100.
- PCT/US01/11340, International Search Report.
- PCT/US01/11420, International Search Report.
- PCT/US02/01890, International Search Report.
- PCT/US02/11100, International Search Report.
- PCT/US04/03436, International Search Report.
- PCT/US04/13273, International Search Report.
- PCT/US04/15311, International Search Report.
- EP 98944778, International Search Report.
- EP 98958575, International Search Report.
- EP 04027479, International Search Report.
- EP 04027705, International Search Report.
- EP 04027314, International Search Report.
- "Innovations in Electrosurgery" *Sales/Product Literature*; Dec. 31, 2000.
- LigaSure Vessel Sealing System, the Seal of Confidence in General, Gynecologic, Urologic, and Laparoscopic Surgery *Sales/Product Literature*; Jan. 2004.
- Olsson et al. "Radical Cystectomy in Females" *Current Surgical Techniques in Urology*, vol. 14, Issue 3, 2001.
- Dulemba et al. "Use of a Bipolar Electrothermal Vessel Sealer in Laparoscopically Assisted Vaginal Hysterectomy" *Sales Product Literature*; Jan. 2004.
- Johnson et al. "Evaluation of a Bipolar electrothermal Vessel Sealing Device in Hemorrhoidectomy" *Sales Product Literature*; Jan. 2004.
- International Search Report PCT/US01/11224 dated Nov. 13, 2001.
- International Search Report EP 98958575.7 dated Sep. 20, 2002.
- International Search Report EP 04013772 dated Apr. 1, 2005.
- International Search Report EP 05013895 dated Oct. 14, 2005.
- International Search Report EP 05017281 dated Nov. 16, 2005.
- Int'l Search Report EP 05013463.4 dated Sep. 28, 2005.
- Int'l Search Report EP 05019130.3 dated Oct. 18, 2005.
- Int'l Search Report EP 05020665.5 dated Feb. 16, 2006.
- Int'l Search Report EP 05020666.3 dated Feb. 17, 2006.
- Int'l Search Report EP 05021779.3 dated Jan. 18, 2006.
- Int'l Search Report EP 05021197.8 dated Jan. 31, 2006.
- Int'l Search Report EP 05021937.7 dated Jan. 13, 2006.
- Int'l Search Report—extended—EP 05021937.7 dated Mar. 6, 2006.
- Int'l Search Report EP 05023017.6 dated Feb. 16, 2006.
- Int'l Search Report EP 05021780.1 dated Feb. 9, 2006.
- Int'l Search Report EP 06002279.5 dated Mar. 22, 2006.
- Int'l Search Report EP 05016399 dated Jan. 5, 2006.
- Int'l Search Report EP 06005185.1 dated Apr. 18, 2006.
- Int'l Search Report EP 06008779.8 dated Jun. 13, 2006.
- Int'l Search Report EP 1683496 dated Jun. 13, 2006.
- Int'l Search Report EP 04013772 dated Apr. 1, 2005.
- Int'l Search Report EP 05013895 dated Oct. 14, 2005.
- Int'l Search Report EP 05017281 dated Nov. 16, 2005.
- Int'l Search Report EP 06006716 dated Aug. 4, 2006.
- Int'l Search Report PCT/US01/11224 dated Nov. 13, 2001.
- Int'l Search Report EP 06014461.5 dated Oct. 20, 2006.
- Int'l Search Report EP 06020584.6 dated Jan. 12, 2007.
- Int'l Search Report EP 06020583.8 dated Jan. 30, 2007.
- Int'l Search Report EP 06020756.0 dated Feb. 5, 2007.
- Int'l Search Report EP 06024123.9 dated Feb. 26, 2007.
- Int'l Search Report EP 04 752343.6 dated Jul. 20, 2007.
- Int'l Search Report EP 06 024122.1 dated Mar. 19, 2007.
- Int'l Search Report EP 07 001480.8 dated Apr. 12, 2007.
- Int'l Search Report EP 07 001488.1 dated May 29, 2007.
- Int'l Search Report—Extended EP 07 009029.5 dated Jul. 12, 2007.
- Int'l Search Report EP 07 009321.6 dated Aug. 17, 2007.

* cited by examiner

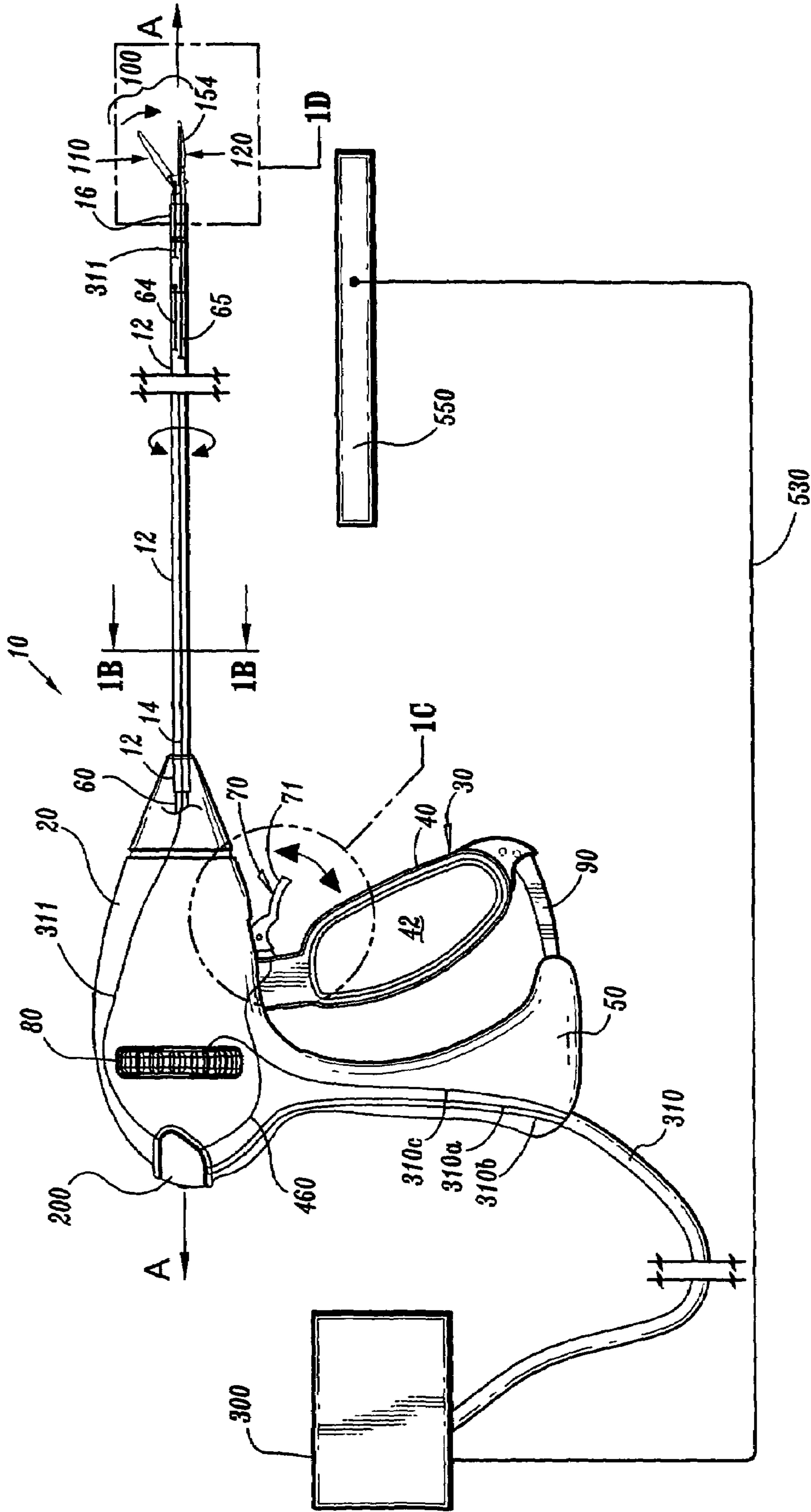

FIG. 1A

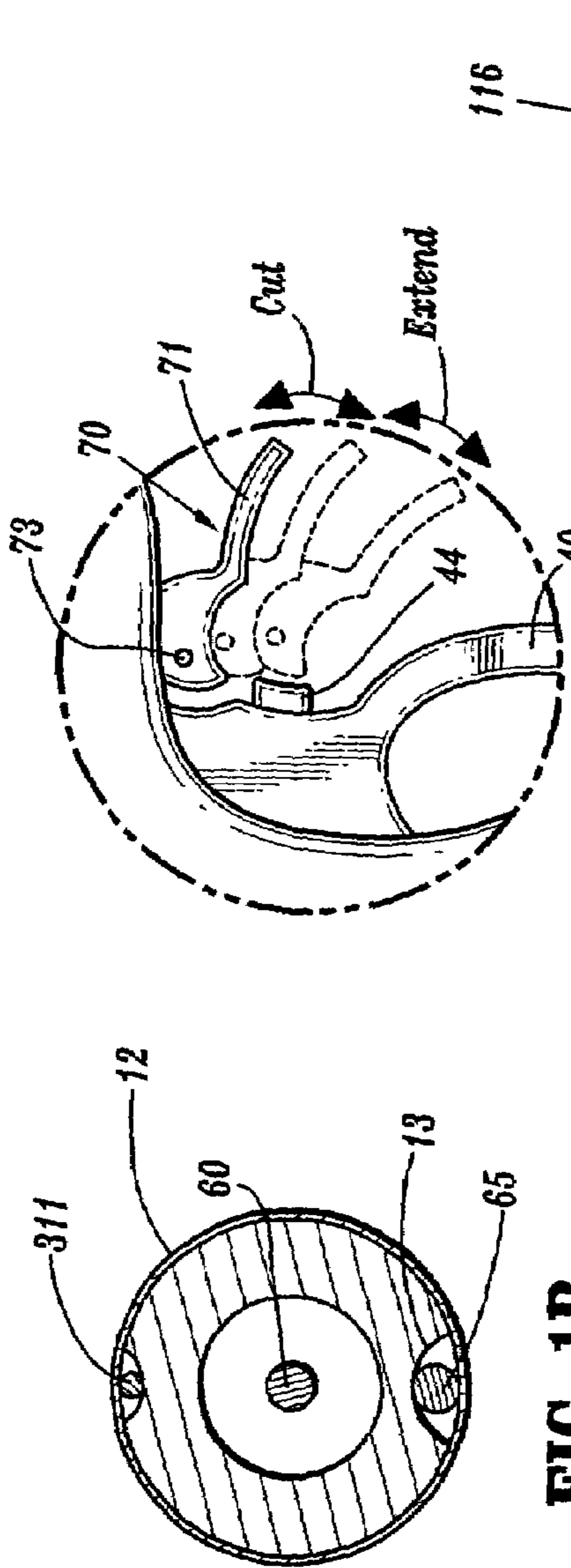

FIG. 1C

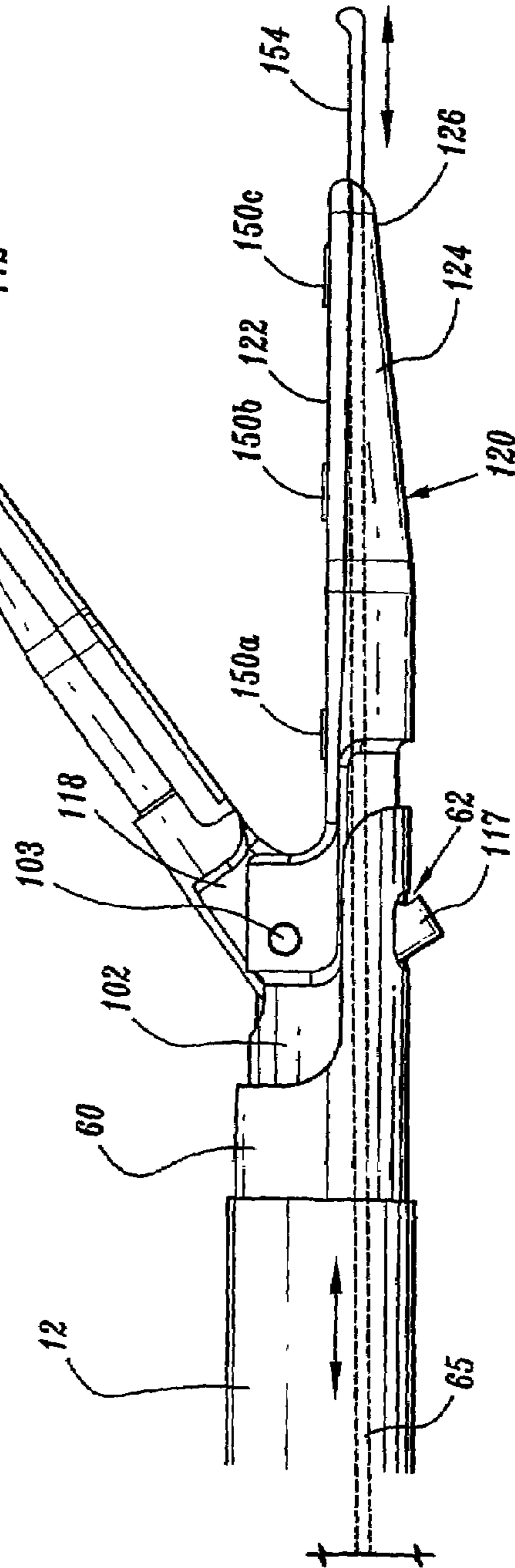

FIG. 1D

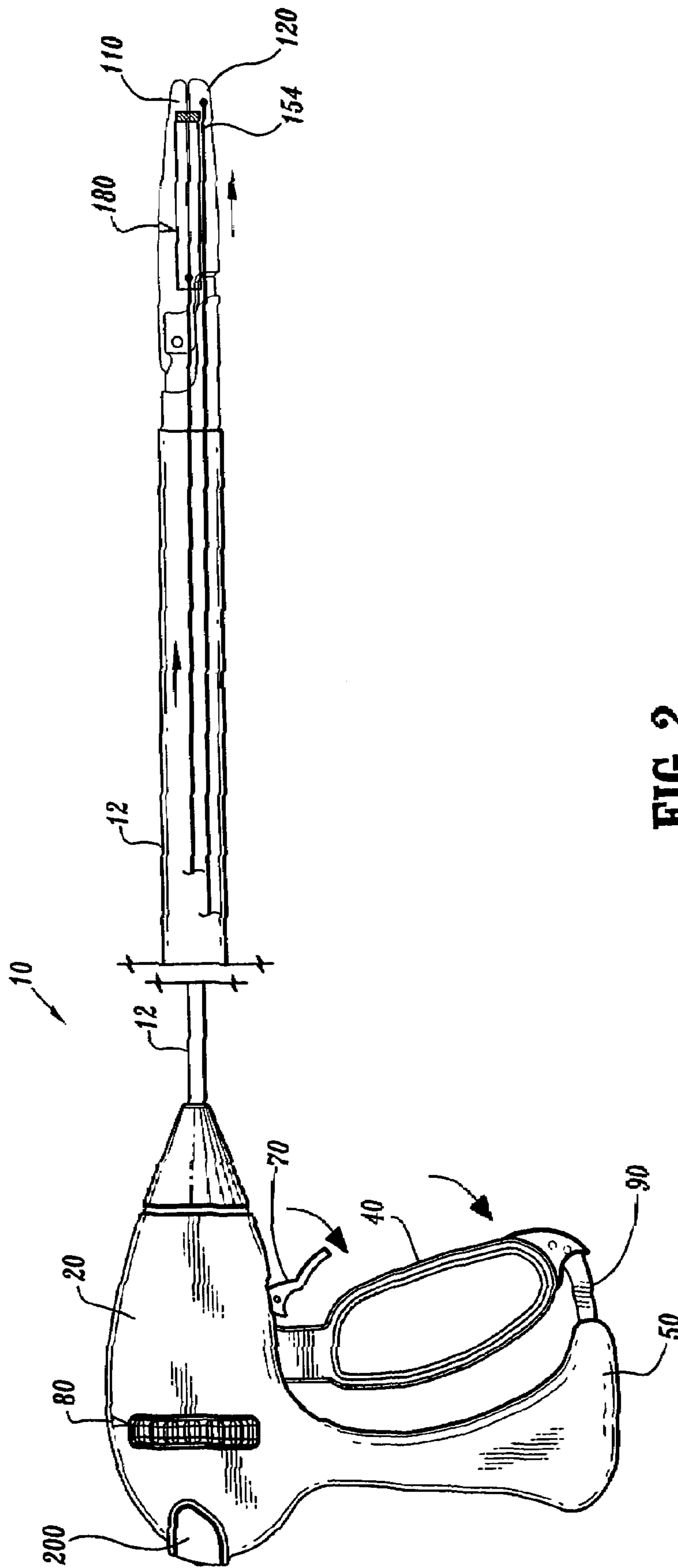

FIG. 2

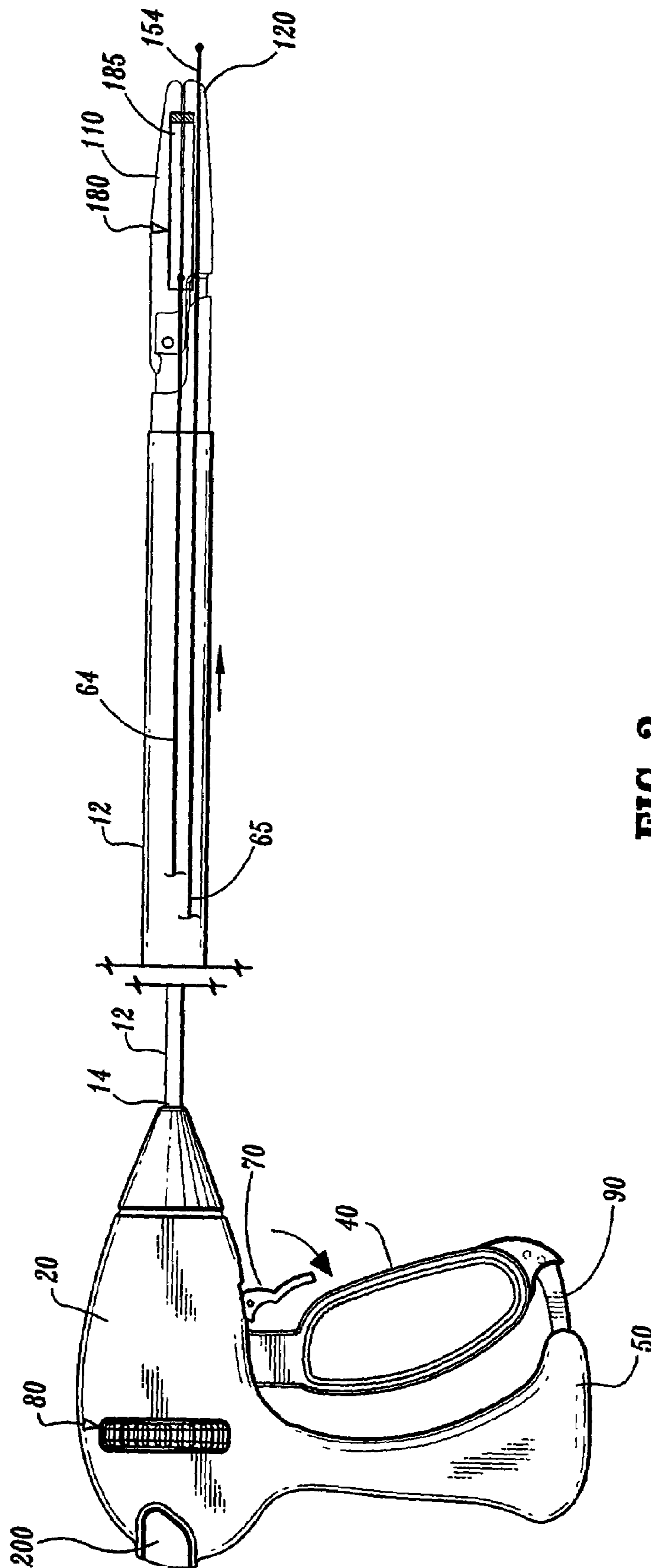

FIG. 3

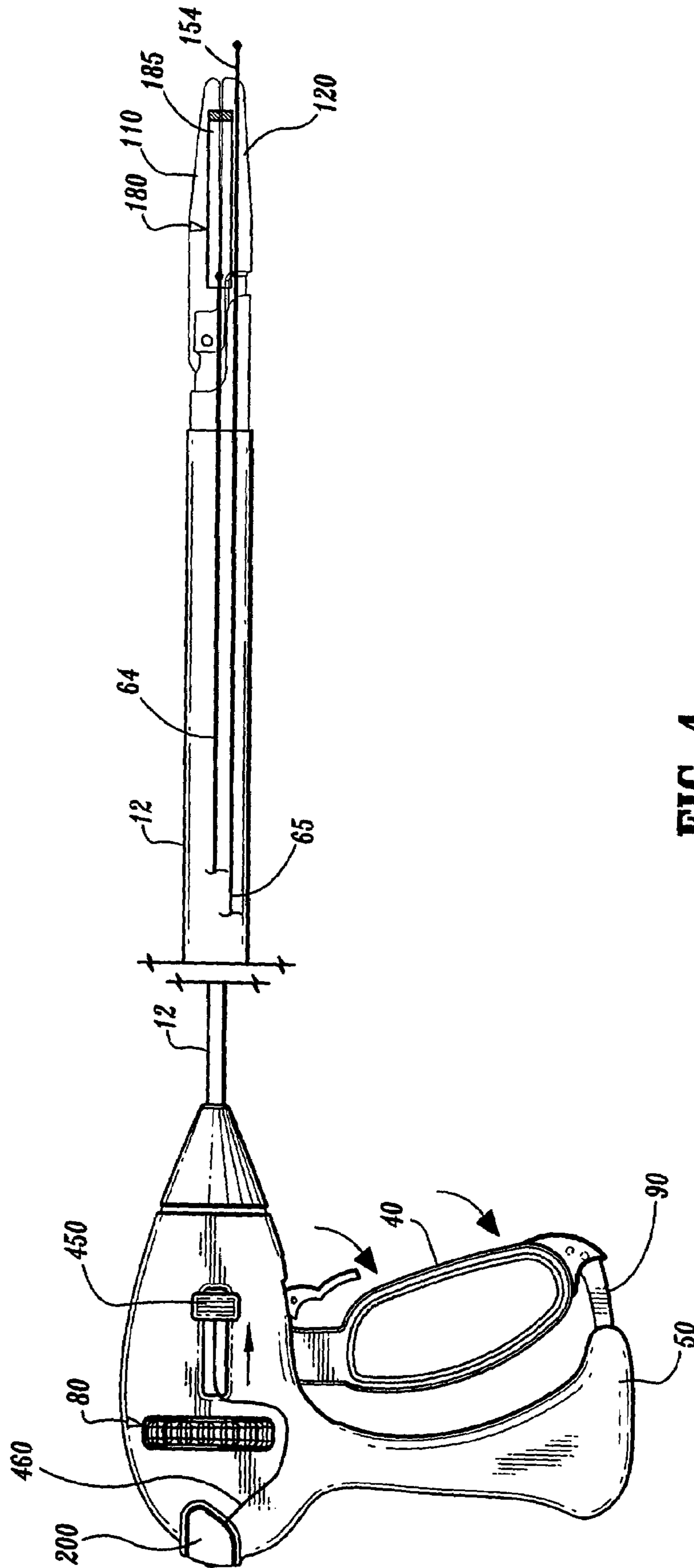
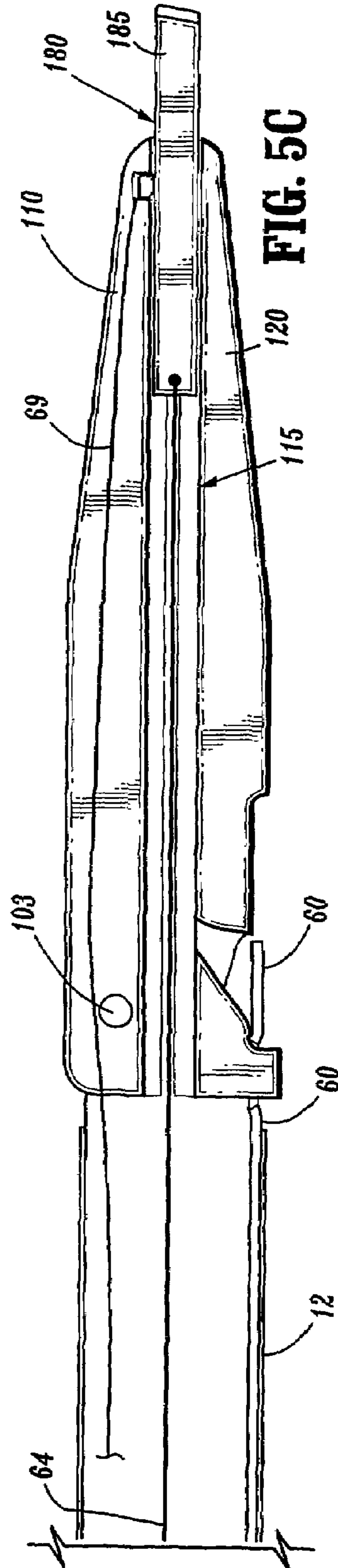
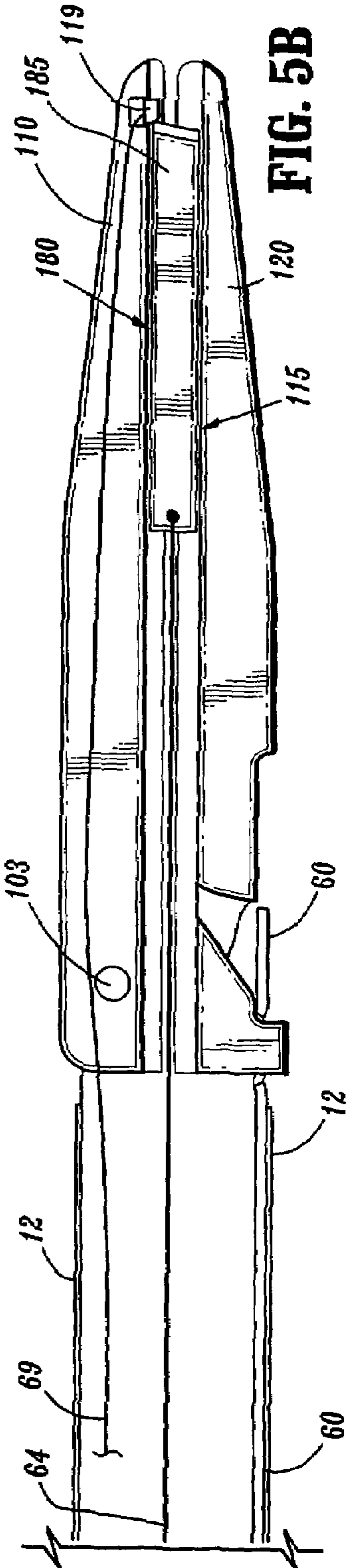
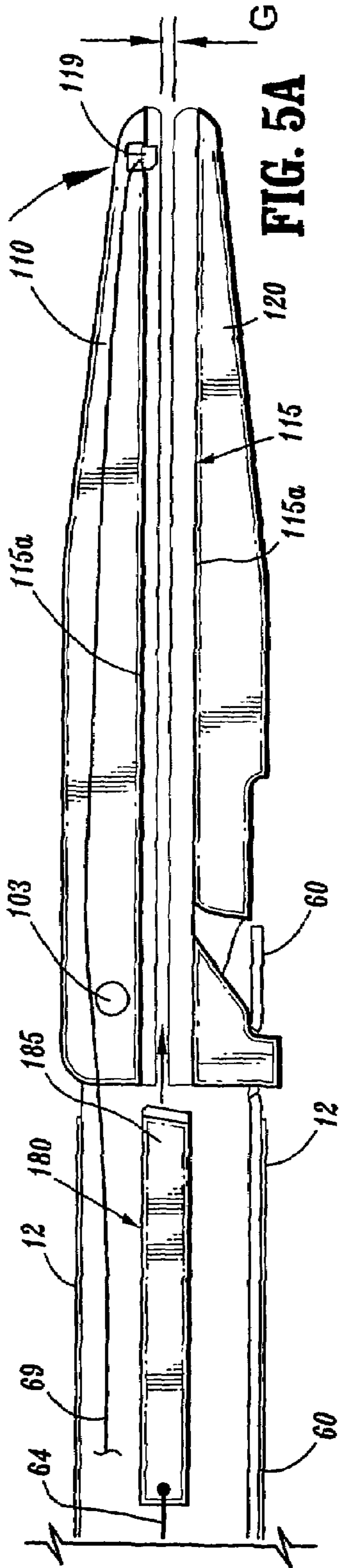

FIG. 4



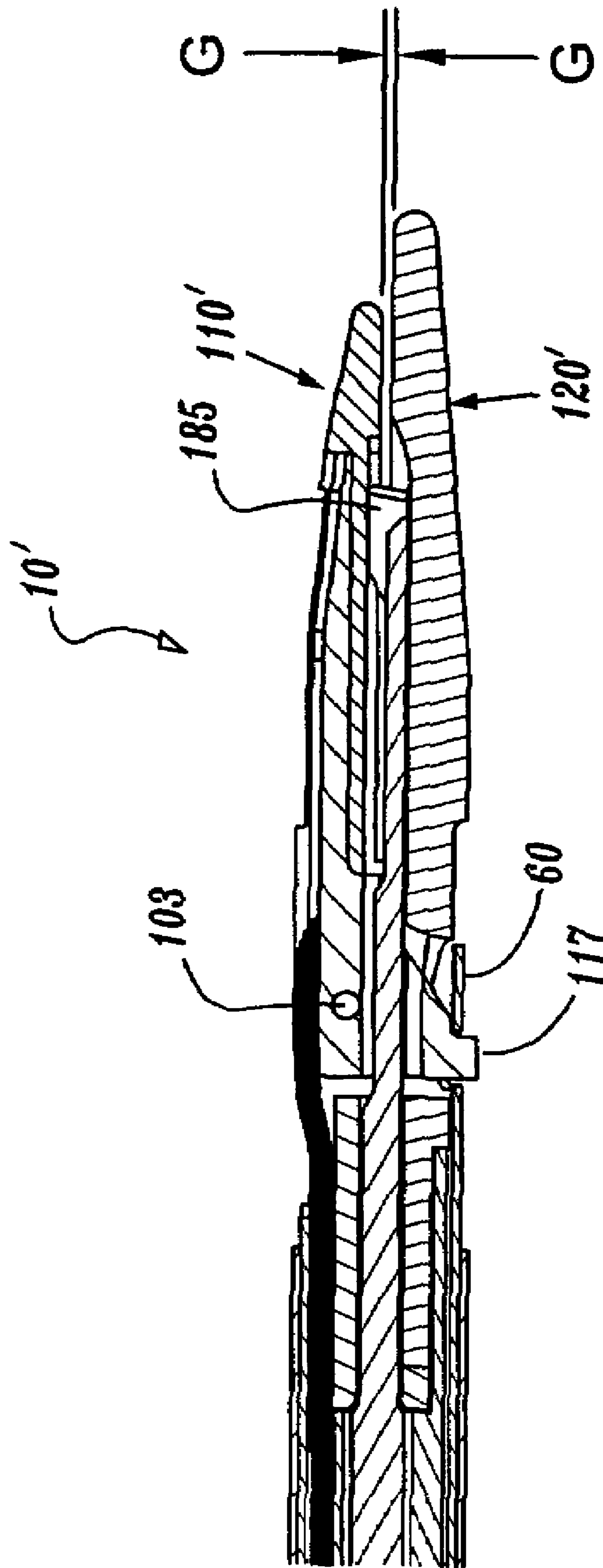

FIG. 6A

Mode	A	B	C
Off	Off	Off	Off
Bi Polar	Off	-	+
Mono Polar	-	+	+

FIG. 6C

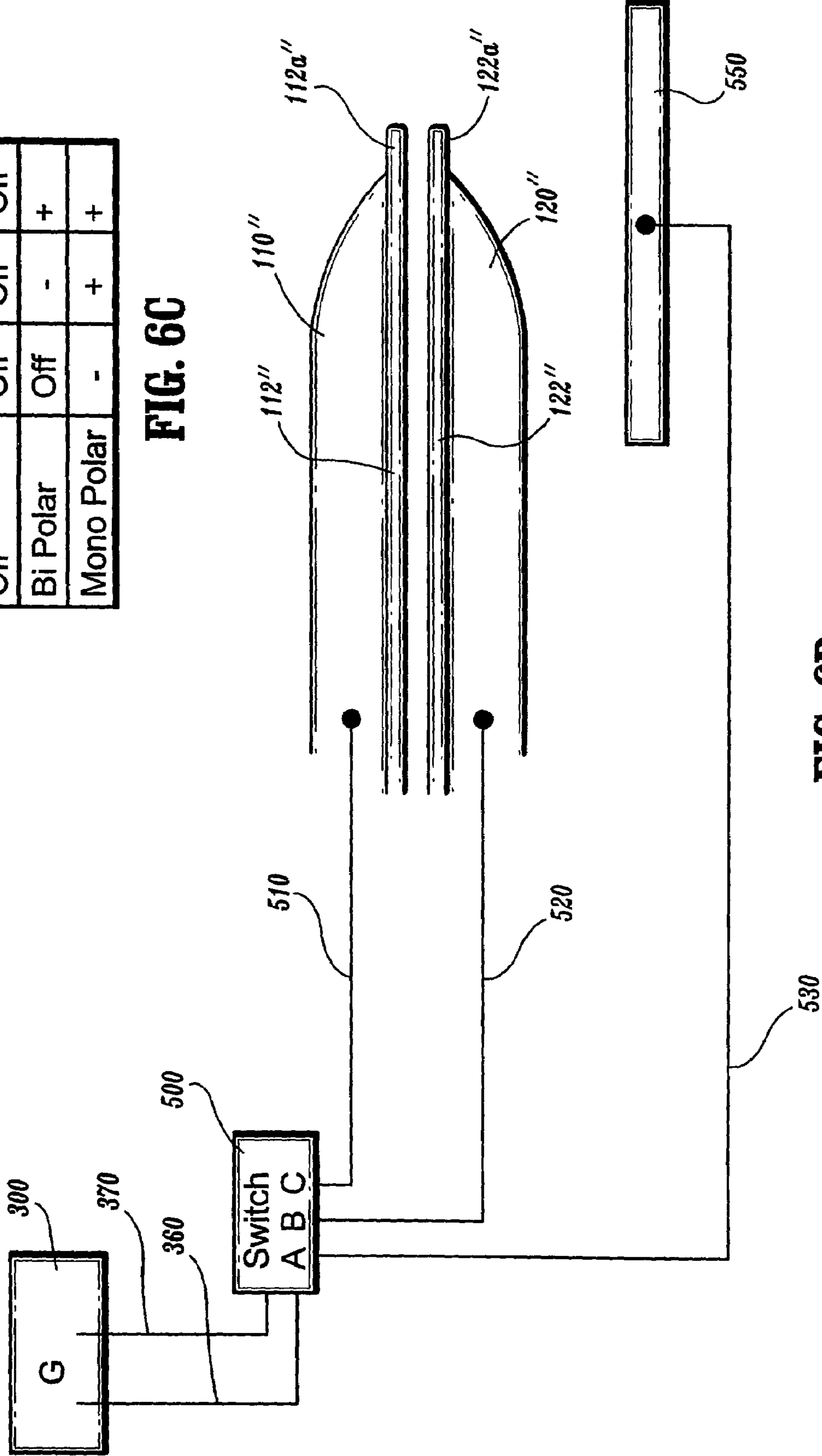

FIG. 6B

1

BIPOLAR FORCEPS HAVING MONOPOLAR EXTENSION**CROSS REFERENCE TO RELATED APPLICATION**

This application claims the benefit of priority to U.S. Provisional Application Ser. No. 60/520,579 file on Nov. 17, 2003 by Lawes et al. Entitled "BIPOLAR FORCEPS HAVING MONOPOLAR EXTENSION" the entire contents of which being incorporated by reference herein.

BACKGROUND

The present disclosure relates to an electro-surgical forceps and more particularly, the present disclosure relates to an endoscopic bipolar electro-surgical forceps for coagulating, sealing and/or cutting tissue having a selectively energizable and/or extendable monopolar extension for enhanced electro-surgical effect.

TECHNICAL FIELD

Electro-surgical forceps utilize both mechanical clamping action and electrical energy to effect hemostasis by heating the tissue and blood vessels to coagulate, cauterize and/or seal tissue. As an alternative to open forceps for use with open surgical procedures, many modern surgeons use endoscopes and endoscopic instruments for remotely accessing organs through smaller, puncture-like incisions. As a direct result thereof, patients tend to benefit from less scarring and reduced healing time.

Endoscopic instruments are inserted into the patient through a cannula, or port, which has been made with a trocar. Typical sizes for cannulas range from three millimeters to twelve millimeters. Smaller cannulas are usually preferred, which, as can be appreciated, ultimately presents a design challenge to instrument manufacturers who must find ways to make endoscopic instruments that fit through the smaller cannulas.

Many endoscopic surgical procedures require cutting or ligating blood vessels or vascular tissue. Due to the inherent spatial considerations of the surgical cavity, surgeons often have difficulty suturing vessels or performing other traditional methods of controlling bleeding, e.g., clamping and/or tying-off transected blood vessels. By utilizing an electro-surgical scissors, the surgeon may cut tissue during a given surgical procedure utilizing a combination of mechanical cutting action and electro-surgical cutting. By utilizing an endoscopic electro-surgical forceps, a surgeon can cauterize, coagulate/desiccate and/or simply reduce or slow bleeding simply by controlling the intensity, frequency and duration of the electro-surgical energy applied through the jaw members to the tissue.

For treating larger vessels, a surgeon may opt to seal the tissue or vessel. Tissue sealing is fundamentally different than simply coagulating or cauterizing vessels. For the purposes herein, "coagulation" is defined as a process of desiccating tissue wherein the tissue cells are ruptured and dried. "Vessel sealing" or "tissue sealing" is defined as the process of liquefying the collagen in the tissue so that it reforms into a fused mass with limited demarcation between adjacent tissue structures. In order to effectively seal larger vessels (or tissue) two predominant mechanical parameters must be accurately controlled—the pressure applied to the vessel (tissue) preferably about 3 kg/cm² to about 16 kg/cm² and the gap distance between the electrodes preferably about

2

0.001 inches to about 0.006 inches. Several examples of endoscopic vessel sealing instruments are disclosed in commonly-owned U.S. patent application Ser. Nos. 10/116,944, 10/179,863, 10/369,894 and 10/180,926 and PCT/US01/11340 the entire contents of all of which are hereby incorporated by reference herein.

Generally, the electrical configuration of electro-surgical forceps can be categorized in two classifications: 1) monopolar electro-surgical forceps; and 2) bipolar electro-surgical forceps. Monopolar forceps utilize one active electrode associated with the clamping end effector and a remote patient return electrode or pad which is attached externally to the patient. When the electro-surgical energy is applied, the energy travels from the active electrode, to the surgical site, through the patient and to the return electrode.

Bipolar electro-surgical forceps utilize two generally opposing electrodes which are disposed on the inner opposing surfaces of end effectors and which are both electrically coupled to an electro-surgical generator. Each electrode is charged to a different electric potential. Since tissue is a conductor of electrical energy, when the effectors are utilized to grasp, seal or cut tissue therebetween, the electrical energy can be selectively transferred through the tissue.

One of the inherent disadvantages to utilizing a bipolar endoscopic forceps for cauterizing, coagulating cutting or sealing vessels and other tissues is the inability of the bipolar forceps to match the benefits or advantages of monopolar instruments (i.e., monopolar instruments have the ability to move through avascular tissue and dissect through narrow tissue planes) necessitating the need for the surgeon to replace the bipolar forceps during surgery to reap the benefits of using the monopolar instrument for certain applications. Likewise, during some monopolar endoscopic applications it may be advantageous to replace the monopolar instrument with a bipolar forceps, e.g., for sealing large tissue structures. For example, during a cholecystectomy the gallbladder is dissected from the liver which would typically entail using an endoscopic monopolar instrument, e.g., electro-surgical blade, electro-surgical pencil, loop electrode, etc. However, during the cholecystectomy procedure there may also be a need to seal the cystic duct or cystic artery which may require a bipolar vessel sealing instrument necessitating the need to replace the monopolar instrument. The surgeon may need to repeatedly remove the monopolar instrument from the operating cavity to utilize the bipolar instrument and vice versa.

Thus there exists a need to develop an instrument which can combine the benefits of both monopolar and bipolar operation thereby reducing the need for the surgeon to substitute instruments during surgical certain procedures.

SUMMARY

The present disclosure relates to an endoscopic forceps for treating tissue and includes a housing having a shaft affixed thereto and first and second jaw members attached to a distal end of the shaft. The forceps also includes an actuator for moving jaw members relative to one another from a first position wherein the jaw members are disposed in spaced relation relative to one another to a second position wherein the jaw members cooperate to grasp tissue therebetween. A source of electro-surgical energy is connected to each jaw member such that the jaw members are selectively capable of operating in a bipolar mode which enables the jaw members to conduct bipolar energy through tissue held therebetween to treat tissue. The forceps also includes a monopolar element housed within at least the first jaw

member which is selectively movable from a first position within the first jaw member to a second position distal to the first jaw member. The monopolar element is connected to the source of electrosurgical energy and is selectively activateable independent of the jaw members.

In one embodiment according to the present disclosure, the forceps includes a knife which is selectively moveable within a knife channel defined within at least one of the first and second jaw members to cut tissue disposed between the first and second jaw members. Advantageously, a knife actuator allows a user to selectively move the knife to cut tissue disposed between the jaw members. The source of electrosurgical energy carries electrical potentials to each respective jaw member such that the jaw members are capable of conducting bipolar energy through tissue held therebetween to effect a tissue seal.

Advantageously, the knife is designed to initially cut tissue disposed between the first and second jaw members and subsequently extend distally from the jaw members to treat tissue in a monopolar fashion. Preferably, the forceps includes a safety (e.g. a safety circuit or mechanical safety element) which only allows electrical activation of the knife (or monopolar element) when the knife (or monopolar element) is extended from the distal ends of the jaw members. The safety may also deactivate the jaw members through circuitry or utilizing a mechanical safety element.

In one embodiment, the first jaw member and the second jaw member each include an elongated slot which runs in opposition substantially along the respective lengths thereof such that the two opposing elongated slots form the knife channel for reciprocating the knife to divide tissue disposed between the two jaw members.

In another embodiment, the forceps is a vessel sealing forceps and at least one of the jaw members includes at least one non-conductive stop member disposed thereon which controls the distance between the first and second jaw members when tissue is held therebetween. Advantageously, the stop member(s) maintains a gap distance of about 0.001 inches to about 0.006 inches between the jaw members when tissue is compressed between the jaw members.

In yet another embodiment according to the present disclosure, the forceps includes an actuator which operates to both move the knife to cut tissue disposed between jaw members and to extend the knife or a separate monopolar element from the first position within the first jaw member to the second position distal to the first jaw member. In still yet another embodiment according to the present disclosure, the forceps includes an actuator which operates to both move the jaw members relative to one another from the first to second positions to grasp tissue therebetween and to extend the monopolar element from the first position within the first jaw member to the second position distal to the first jaw member.

In another embodiment according to the present disclosure, a first actuator may be designed to operate the jaw members for grasping tissue and a second actuator may be included which operates to extend the monopolar element from the first position within the first jaw member to the second position distal to the first jaw member.

The present disclosure also relates to an endoscopic forceps which includes a housing having a shaft affixed thereto and first and second jaw members attached to a distal end of the shaft. The first jaw member is configured to extend distally relative to the second jaw member. An actuator is included for moving jaw members relative to one another from a first position wherein the jaw members are disposed in spaced relation relative to one another to a second position

wherein the jaw members cooperate to grasp tissue therebetween. The jaw members are connected to a source of electrosurgical energy such that the jaw members are selectively capable of operating in a bipolar mode which enables the jaw members to conduct bipolar energy through tissue held therebetween.

The forceps also includes a control switch which, upon selective activation, deactivates the second jaw member and activates the first jaw member with a first electrical potential. At relatively the same time, the control switch also activates a return electrode or return pad with a different electrical potential which is placed adjacent to the patient to enable the first jaw member to selectively treat tissue in a monopolar fashion. Preferably, a safety is included which limits electrical activation of the control switch to when the jaw members are disposed in the second position.

The present disclosure also relates to an endoscopic forceps which includes a housing having a shaft affixed thereto. The shaft includes first and second jaw members attached to a distal end thereof. Preferably, the first and second jaw members each include a tapered or elongated distal end.

The forceps also includes an actuator for moving jaw members relative to one another from a first position wherein the jaw members are disposed in spaced relation relative to one another to a second position wherein the jaw members cooperate to grasp tissue therebetween. A source of electrosurgical energy is connected to each jaw member such that the jaw members are selectively capable of operating in a bipolar mode which enables the jaw members to conduct bipolar energy through tissue held therebetween.

A control switch is also included which, upon selective activation thereof, activates the first jaw member and the second jaw member with a first electrical potential and activates a return electrode with a different electrical potential. The return electrode is preferably placed adjacent to the patient which enables the first and second jaw members to selectively treat tissue in a monopolar fashion. Preferably, the forceps includes a safety which only allows electrical activation of the control switch when the jaw members are disposed in the second position.

In another embodiment of the present disclosure, the actuator is selectively lockable to maintain a closure pressure in the range of about 3 kg/cm² to about 16 kg/cm² and, preferably, about 7 kg/cm² to about 13 kg/cm² between the jaw members which is advantageous in producing effective and reliable tissue seals. In yet another embodiment, the forceps may also include a rotating assembly for rotating the jaw members about a longitudinal axis defined through the shaft. Advantageously, the forceps includes a unilateral jaw assembly, i.e., the first jaw member is movable relative to the second jaw member and the second jaw member is substantially fixed.

Alternatively, the forceps may include a bilateral jaw assembly, i.e., both jaw members move relative to one another.

Preferably, a spring is included with the actuator or drive assembly to facilitate actuation of the movable handle and to assure the closure force is maintained within a working range of about 3 kg/cm² to about 16 kg/cm².

The present disclosure also relates to a method for treating tissue with electrosurgical energy from an electrosurgical generator which includes the steps of: providing an endoscopic forceps including a housing having a shaft affixed thereto. The shaft includes first and second jaw members attached to a distal end thereof. An actuator is included for moving jaw members relative to one another from a first

5

position wherein the jaw members are disposed in spaced relation relative to one another to a second position wherein the jaw members cooperate to grasp tissue therebetween. A monopolar element is also included which is housed within at least the first jaw member and selectively movable from a first position within the first jaw member to a second position distal to the first jaw member. A return electrode is provided and placed in contact with patient tissue.

The method also includes the steps of: connecting to each jaw member, the monopolar element and the return electrode to the electrosurgical generator; grasping tissue between the jaw members; selectively activating the jaw members to treat tissue disposed between the jaw members in a bipolar fashion; and selectively activating the monopolar element and the return electrode independent of the jaw members to treat tissue in a monopolar fashion.

Preferably, after the step of selectively activating the jaw members to treat tissue, the method includes the step of: extending the monopolar element from the distal end of the jaw members. Advantageously, the step of selectively activating the monopolar element includes deactivating the jaw members.

After the step of selectively activating the jaw members to treat tissue, the method may include the step of: releasing the tissue from the jaw members.

BRIEF DESCRIPTION OF THE DRAWINGS

Various embodiments of the subject instrument are described herein with reference to the drawings wherein:

FIG. 1A is a side view of an endoscopic forceps showing a housing, a shaft, an end effector assembly and a trigger assembly in a first position according to the present disclosure;

FIG. 1B is an enlarged, cross section taken along line 1B-1B of FIG. 1A;

FIG. 1C is an enlarged, side view of the trigger assembly of FIG. 1A;

FIG. 1D is an enlarged, side view of the embodiment of an end effector assembly of FIG. 1A showing relative extension of a monopolar element from a distal end of the end effector assembly;

FIG. 2 is a side view of the trigger assembly in a second position for advancing a knife within the end effector assembly;

FIG. 3 is a side view of the trigger assembly in a third position for extending a monopolar element from a distal end of the end effector assembly;

FIG. 4 is a side view of an alternate embodiment of the present invention showing a second actuator advancing the monopolar element relative to the distal end of the end effector assembly;

FIG. 5A is an enlarged, side schematic view of one embodiment of an end effector assembly showing relative movement of a first jaw member relative to a second jaw member prior to advancement of the knife through the end effector assembly;

FIG. 5B is an enlarged, side schematic view of the end effector assembly showing relative movement of the knife through the end effector assembly to divide tissue;

FIG. 5C is an enlarged, side schematic view of the end effector assembly showing relative movement of the knife extending from the distal end of the end effector assembly;

FIG. 6A is an enlarged, side schematic view of another embodiment of an end effector assembly showing a first jaw member extending beyond a second jaw member;

6

FIG. 6B is schematic view of another embodiment of an end effector assembly showing a series of electrical connections to a control switch and a generator to enable both bipolar activation and monopolar activation; and

FIG. 6C is a table showing the various modes of operation of the forceps utilizing the end effector configuration of FIG. 6B.

DETAILED DESCRIPTION

Turning now to FIGS. 1A-1D, one embodiment of an endoscopic forceps **10** is shown for use with various surgical procedures. For the purposes herein, a vessel sealing forceps is shown and described, however, it is envisioned that other types of forceps or scissors may be utilized which both treat tissue for cauterization, coagulation or other purposes and which may be configured for monopolar applications as described herein. Moreover, although the figure drawings depict a forceps **10** for use in connection with endoscopic surgical procedures, the present disclosure may be used for more traditional open surgical procedures. For the purposes herein, the forceps **10** is described in terms of an endoscopic instrument, however, it is contemplated that an open version of the forceps **10** may also include the same or similar operating components and features as described below.

Forceps **10** generally includes a housing **20**, a handle assembly **30**, a rotating assembly **80**, a trigger assembly **70** and an end effector assembly **100** which mutually cooperate to grasp, treat and divide tissue. For the purposes herein, the handle assembly **30**, rotating assembly, trigger assembly **70** and end effector assembly **100** are only generally described. A more detailed explanation of all of these cooperating elements are described in commonly owned, co-pending U.S. patent application Ser. No. 10/460,926 the entire contents of which is hereby incorporated by reference herein.

Forceps **10** includes a shaft **12** which has a distal end **16** dimensioned to mechanically engage the end effector assembly **100** and a proximal end **14** which mechanically engages the housing **20**. In the drawings and in the descriptions which follow, the term "proximal", as is traditional, will refer to the end of the forceps **10** which is closer to the user, while the term "distal" will refer to the end which is further from the user. Details of how the shaft **12** connects to the end effector assembly **100** and how the proximal end connects to the housing **20** are explained in the above-mentioned commonly owned, co-pending U.S. patent application Ser. No. 10/460,926.

As best seen in FIG. 1A, forceps **10** also includes an electrosurgical cable **310** which connects the forceps **10** to a source of electrosurgical energy, e.g., a generator **300**. Cable **310** is internally divided into cable leads **310a**, **310b** and **310c** which each transmit electrosurgical energy through their respective feed paths through the forceps **10** to the end effector assembly **100** as explained in more detail with respect to U.S. patent application Ser. No. 10/460,926. Preferably, generators such as those sold by Valleylab—a division of Tyco Healthcare LP, located in Boulder Colo. are used as a source of electrosurgical energy, e.g., FORCE EZ™ Electrosurgical Generator, FORCE FX™ Electrosurgical Generator, FORCE 1C™ Electrosurgical Generator, FORCE 2™ Electrosurgical Generator, SurgiStat™ II Electrosurgical Generator. One such system is described in commonly-owned U.S. Pat. No. 6,033,399 the entire contents of which are hereby incorporated by reference herein. Other systems have been described in commonly-owned U.S. Pat. No. 6,187,003 the entire contents of which is also incorporated by reference herein.

Preferably, the generator **300** includes various safety and performance features including isolated output, independent activation of accessories. Preferably, the electrosurgical generator **300** includes Valleylab's Instant Response™ technology which provides an advanced feedback system to sense changes in tissue **200** times per second and adjust voltage and current to maintain appropriate power.

Handle assembly **30** includes a fixed handle **50** and a movable handle **40**. Fixed handle **50** is integrally associated with housing **20** and handle **40** is movable relative to fixed handle **50**. Rotating assembly **80** is preferably integrally associated with the housing **20** and is rotatable approximately 180 degrees in either direction about a longitudinal axis "A". Details of the handle assembly **30** and the rotating assembly **80** are described in more detail with respect to U.S. patent application Ser. No. 10/460,926.

As mentioned above, end effector assembly **100** is attached at the distal end **16** of shaft **12** and includes a pair of opposing jaw members **110** and **120**. Movable handle **40** of handle assembly **30** is ultimately connected to an internally disposed drive assembly (not shown) which, together, mechanically cooperate to impart movement of the jaw members **110** and **120** from an open position wherein the jaw members **110** and **120** are disposed in spaced relation relative to one another, to a clamping or closed position wherein the jaw members **110** and **120** cooperate to grasp tissue therebetween.

Turning now to the more detailed features of one embodiment of the present disclosure as described with respect to FIGS. 1A-3, movable handle **40** includes an aperture **42** defined therethrough which enables a user to grasp and move the handle **40** relative to the fixed handle **50**. More particularly, handle **40** is selectively moveable about a pivot (not shown) from a first position relative to fixed handle **50** to a second position in closer proximity to the fixed handle **50** which imparts movement of the jaw members **110** and **120** relative to one another.

The lower end of the movable handle **40** includes a flange **90** which, upon movement of the handle **40** proximally, is reciprocated within fixed handle **50**. Flange **90** rides within a predefined channel (not shown) disposed within fixed handle **50** to lock the movable handle **40** relative to the fixed handle **50**.

As best shown in FIG. 1C, a locking flange **44** is disposed on the outer periphery of the handle **40** above the upper portion of the handle **40**. Locking flange **44** prevents the trigger assembly **70** from firing when the handle **40** is oriented in a non-actuated position, i.e., the jaw members **110** and **120** are open. As can be appreciated, this prevents accidental or premature severing of tissue prior to completion of a tissue seal.

As explained in detail in co-pending U.S. patent application Ser. No. 10/460,926, movable handle **40** is designed to provide a distinct mechanical advantage over conventional handle assemblies due to the unique position of the pivot point relative to the longitudinal axis "A" of the shaft **12**. In other words, by positioning the pivot point above the driving element, the user gains lever-like mechanical advantage to actuate the jaw members **110** and **120** enabling the user to close the jaw members **110** and **120** with lesser force while still generating the required forces necessary to effect a proper and effective tissue seal. It is also envisioned that the unilateral design of the end effector assembly **100** will also increase mechanical advantage.

As best seen in FIGS. 1A and 1D, the end effector assembly **100** includes opposing jaw members **110** and **120** which cooperate to effectively grasp tissue for sealing pur-

poses. The end effector assembly **100** is designed as a unilateral assembly, i.e., jaw member **120** is fixed relative to the shaft **12** and jaw member **110** pivots about a pivot pin **103** to grasp tissue.

More particularly, the unilateral end effector assembly **100** includes one stationary or fixed jaw member **120** mounted in fixed relation to the shaft **12** and pivoting jaw member **110** mounted about a pivot pin **103** attached to the stationary jaw member **120**. A reciprocating sleeve **60** is slidably disposed within the shaft **12** and is remotely operable by the drive assembly (not shown) which cooperates with handle **40** as explained above to open and close the jaw members **110** and **120**. The pivoting jaw member **110** includes a detent or protrusion **117** which extends from jaw member **110** through an aperture **62** disposed within the reciprocating sleeve **60** (FIG. 1D). The pivoting jaw member **110** is actuated by sliding the sleeve **60** axially within the shaft **12** such that aperture **62** abuts against the detent **117** on the pivoting jaw member **110**. Pulling the sleeve **60** proximally closes the jaw members **110** and **120** about tissue grasped therebetween and pushing the sleeve **60** distally opens the jaw members **110** and **120** for approximating and grasping purposes.

Once actuated, handle **40** moves in a generally arcuate fashion towards fixed handle **50** about the pivot point which forces the driving flange (not shown) proximally against the drive assembly (not shown) which, in turn, pulls reciprocating sleeve **60** in a generally proximal direction to close jaw member **110** relative to jaw member **120**. Moreover, proximal rotation of the handle **40** causes the locking flange **44** to release, i.e., "unlock" the trigger assembly **70** for selective actuation. These features are shown and explained in detail with reference to commonly-owned, co-pending U.S. application Ser. No. 10/460,926.

As best illustrated in FIGS. 5A-5C, a knife channel **115a** and **115b** runs through the center of the jaw members **110** and **120**, respectively, such that a blade **185** can cut tissue grasped between the jaw members **110** and **120** when the jaw members **110** and **120** are in a closed position. More particularly, the blade **185** can only be advanced through the tissue when the jaw members **110** and **120** are closed thus preventing accidental or premature activation of the blade **185** through tissue. Put simply, the knife channel **115** (made up of half channels **115a** and **115b**) is blocked when the jaws members **110** and **120** are opened and aligned for distal activation when the jaw members **110** and **120** are closed.

As best shown in FIG. 1D, jaw member **110** includes a jaw housing **116** which has an insulative substrate or insulator **114** and an electrically conductive surface **112**. Insulator **114** is preferably dimensioned to securely engage the electrically conductive sealing surface **112**. This may be accomplished by stamping, by overmolding, by overmolding a stamped electrically conductive sealing plate, by overmolding a metal injection molded seal plate and/or other ways known in the art. It is envisioned a trigger lead **311** from switch **200** electrically connects to the seal plate **112**.

All of these manufacturing techniques produce jaw member **110** having an electrically conductive surface **112** which is substantially surrounded by an insulating substrate **114**. The insulator **114**, electrically conductive sealing surface **112** and the outer, non-conductive jaw housing **116** are preferably dimensioned to limit and/or reduce many of the known undesirable effects related to tissue sealing, e.g., flashover, thermal spread and stray current dissipation.

As best seen in FIG. 1D, jaw member **110** also includes a pivot flange **118** which includes protrusion **117**. Protrusion **117** extends from pivot flange **118** and includes an arcuately-

shaped inner surface dimensioned to matingly engage the aperture 62 of sleeve 60 upon retraction thereof. Pivot flange 118 is also dimensioned to engage pivot pin 103 to allow jaw member 110 to rotate relative to jaw member 120 upon retraction of the reciprocating sleeve 60. Pivot pin 103 also mounts to the stationary jaw member 120 within a proximal portion of jaw member 120.

Preferably, the electrically conductive surface 112 and the insulator 114, when assembled, form the longitudinally-oriented knife slot 115a defined therethrough for reciprocation of the knife blade 185. As mentioned above, knife channel 115a cooperates with corresponding knife channel 115b defined in stationary jaw member 120 to facilitate longitudinal translation of the knife blade 185 along a preferred cutting plane to effectively and accurately separate tissue along the formed tissue seal.

Jaw member 120 includes similar elements to jaw member 110 such as jaw housing 126 having an insulator 124 and an electrically conductive sealing surface 122 which is dimensioned to securely engage the insulator 124. Likewise, the electrically conductive surface 122 and the insulator 124, when assembled, include longitudinally-oriented channel 115b defined therethrough for reciprocation of the knife blade 185. As mentioned above, when the jaw members 110 and 120 are closed about tissue 420, knife channels 115a and 115b form a complete knife channel 115 to allow longitudinal translation of the knife 185 in a distal fashion to sever tissue along the tissue seal.

As mentioned above, jaw member 120 may include a series of stop members 150a-150c preferably disposed on the inner facing surfaces of the electrically conductive sealing surface 122 to facilitate gripping and manipulation of tissue and to define a gap "G" (FIG. 5A) between opposing jaw members 110 and 120 during sealing and cutting of tissue. It is envisioned that the series of stop members 150a-150c may be employed on one or both jaw members 110 and 120 depending upon a particular purpose or to achieve a desired result. A detailed discussion of these and other envisioned stop members 150a-150c as well as various manufacturing and assembling processes for attaching and/or affixing the stop members 150a-150c to the electrically conductive sealing surfaces 112, 122 are described in commonly-assigned, co-pending U.S. Application Serial No. PCT/US01/11413 which is hereby incorporated by reference in its entirety herein.

Jaw member 120 is designed to be fixed to the end of a rotating tube (not shown) which is part of the rotating assembly 80 such that rotation of the tube will impart rotation to the end effector assembly 100. Jaw member 120 is connected to a second electrical potential through the rotating tube (not shown) which is connected at its proximal end to a lead 310c from cable 310. Details relating to the mechanical and electromechanical engagement of the jaw member 120 to the rotating assembly 80 are described in above-mentioned, commonly-owned, co-pending U.S. patent application Ser. No. 10/460,926.

As mentioned above, the jaw members 110 and 120 may be opened, closed and rotated to manipulate tissue until sealing is desired. This enables the user to position and re-position the forceps 10 prior to activation and sealing. As illustrated in FIG. 1A, the end effector assembly 100 is rotatable about longitudinal axis "A" through rotation of the rotating assembly 80. It is envisioned that the unique feed path of the trigger lead 311 from the switch 200 through the rotating assembly 80, along shaft 12 and, ultimately, to the jaw member 110 enables the user to rotate the end effector assembly 100 about 180 degrees in both the clockwise and

counterclockwise direction without tangling or causing undue strain on the cable lead. The other cable lead 310c from cable 310 is fused or clipped to the proximal end of the rotating tube (not shown) and is generally unaffected by rotation of the jaw members 110 and 120. As can be appreciated, this facilitates the grasping and manipulation of tissue.

Again as best shown in FIGS. 1A and 1C, trigger assembly 70 mounts atop movable handle 40 and cooperates with the knife assembly 180 (FIGS. 2, 3, 4, and 5A-5C) to selectively translate knife 185 through a tissue seal. More particularly, the trigger assembly 70 includes a finger actuator 71 and a pivot pin 73 which mounts the trigger assembly 70 to the housing 20. Finger actuator 71 is dimensioned to abut the locking flange 44 on handle 40 when the handle 40 is disposed in a non-actuated position, i.e., the jaw members 110 and 120 are opened.

The trigger assembly 70 is designed to cooperate with a drive bar 64 which connects to the knife assembly 180. Proximal activation of the finger actuator 71 rotates the trigger assembly 70 about pivot pin 73 which, in turn, forces the drive bar 64 distally, which ultimately extends the knife 185 through tissue. A spring (not shown) may be employed to bias the knife assembly 180 in a retracted position such that after severing tissue the knife 185 and the knife assembly 180 are automatically returned to a pre-firing position. In addition, when the handle 40 is actuated and flange 90 is fully reciprocated within fixed handle 50, the locking flange 44 moves proximally allowing activation of the trigger assembly 70.

As best shown in FIG. 1A, the cable 310 is fed through the bottom of the housing 20 through fixed handle 50. A first lead 310c extends directly from cable 310 into the rotating assembly 80 and connects (via a fused clip or spring clip or the like) to tube 60 to conduct the second electrical potential to fixed jaw member 120. Second and third leads 310a and 310b extend from cable 310 and connect to the hand switch or joy-stick-like toggle switch 200. Switch 200 permits the user to selectively activate the forceps 10 in a variety of different orientations, i.e., multi-oriented activation which simplifies activation. When the switch 200 is depressed, a trigger lead 311 carries the first electrical potential to jaw member 110. More particularly, the trigger lead 311 extends from switch 200 through the rotating assembly 80 and along the upper portion of the rotating tube (not shown) and eventually connects to the movable jaw member 110. As can be appreciated, locating the switch 200 on the forceps 10 has many advantages. For example, the switch 200 reduces the amount of electrical cable in the operating room and eliminates the possibility of activating the wrong instrument during a surgical procedure due to "line-of-sight" activation.

As explained in detail above, the second electrical potential (i.e., lead 310c) is conducted to jaw member 120 through the rotating tube. The two potentials are preferably isolated from one another by insulative sheathing (or the like) which surrounds the trigger lead. Preferably, the jaw members 110 and 120 are electrically isolated from one another such that bipolar electrosurgical energy can be effectively transferred through the tissue to form a tissue seal.

Once the desired position for the sealing site is determined and the jaw members 110 and 120 are properly positioned, handle 40 may be compressed fully such that the flange 90 is reciprocated and locked within fixed handle 50. Handle 40 is now secured in position relative to fixed handle 50 which, in turn, locks the jaw members 110 and 120 in a closed position about tissue. The forceps 10 is now ready for selective application of electrosurgical energy and subse-

11

quent separation of tissue, i.e., when movable handle **10** reciprocates within fixed handle **50**, locking flange **44** moves into a position to permit activation of the trigger assembly **70** as explained above.

As can be appreciated, the combination of the mechanical advantage of the over-the-center pivot along with the assisting compressive forces associated with a compression spring (not shown) facilitate and assure consistent, uniform and accurate closure pressure about tissue within the desired working pressure range of about 3 kg/cm² to about 16 kg/cm² and, preferably about 7 kg/cm² to about 13 kg/cm². As mentioned above, at least one jaw member, e.g., **120**, may include a stop member e.g., **150a**, which limits the movement of the two opposing jaw members **110** and **120** relative to one another. Preferably, a series of stop members are to yield a consistent and accurate gap distance "G" during sealing (FIG. 5A) which ranges from about 0.001 inches to about 0.006 inches and, more preferably, between about 0.002 and about 0.003 inches. By controlling the intensity, frequency and duration of the electrosurgical energy applied to the tissue, the user can effectively seal the tissue along a predetermined tissue site.

As energy is being selectively transferred to the end effector assembly **100**, across the jaw members **110** and **120** and through the tissue, a tissue seal forms isolating two tissue halves. At this point and with other known vessel sealing instruments, the user must remove and replace the forceps **10** with a cutting instrument (not shown) to divide the tissue halves along the tissue seal which is both time consuming and tedious and may result in inaccurate tissue division across the tissue seal due to misalignment or misplacement of the cutting instrument along the ideal tissue cutting plane.

The present disclosure incorporates knife assembly **180** which, when activated via the trigger assembly **70**, progressively and selectively divides the tissue along an ideal tissue plane in precise manner to effectively and reliably divide the tissue. The knife assembly **180** allows the user to quickly separate the tissue immediately after sealing without substituting a cutting instrument through a cannula or trocar port. As can be appreciated, accurate sealing and dividing of tissue is accomplished with the same forceps **10**.

Once the tissue is divided into tissue halves, the jaw members **110** and **120** may be opened by re-grasping the handle **40** which release the flange **90** from fixed handle **50**. Details relating to the releasing of the flange from handle are described in commonly-owned, co-pending U.S. application Ser. No. 10/460,926.

Turning now to the operating characteristics of the present disclosure and as seen in the majority of the figures, forceps **10** is designed for both bipolar electrosurgical treatment of tissue (either by vessel sealing as described above or coagulation or cauterization with other similar instruments) and monopolar treatment of tissue. For example, FIGS. 1A-D and 2-4 show one embodiment of a forceps **10** which includes a monopolar element **154** which may be selectively extended and selectively activated to treat tissue. FIGS. 5A-5C show an alternate embodiment of the present disclosure which shows that the knife **185** may be extended from the distal end of the end effector assembly **100** and selectively energized to treat tissue in a monopolar fashion. FIG. 6A shows another embodiment wherein the bottom jaw member **120'** extends distally from the top jaw member **110'** to allow the surgeon to selectively energize the bottom jaw member **120'** and treat tissue in a monopolar fashion. FIG. 6B shows yet another embodiment wherein the jaw members **110"** and **120"** include tapered distal ends which are

12

selectively energized with a single electrical potential to treat tissue in a monopolar fashion.

FIGS. 1A-1D and 2-4 show one embodiment wherein a monopolar element **154** is housed for selective extension within one jaw member, e.g., jaw member **120**, of the end effector assembly **100**. More particularly, monopolar element **154** is designed to move independently from knife assembly **180** and may be extended by further proximal movement of the trigger assembly **70** (FIGS. 1A, 2 and 3) or by a separate actuator **450** (FIG. 4).

Preferably, the monopolar element **154** is connected to a reciprocating rod **65** which extends through an elongated notch **13** in the outer periphery of the shaft **12** as best seen in FIG. 1B. Drive rod **60** which actuates the knife **185** extends through the inner periphery of shaft **12**. In order to extend the monopolar element **154**, the jaw members **110** and **120** are initially closed and the knife **185** is advanced distally utilizing the trigger assembly **70** (See FIG. 2). As best shown in FIG. 1C, the trigger **71** is initially advanced to translate the knife **185** distally to cut through tissue, i.e., the "cut" stage (shown in phantom). Thereafter and as shown in FIG. 3, the trigger **71** may be further actuated in a proximal direction to extend the monopolar element **154**, i.e., the "extend" stage (shown in phantom).

It is envisioned that the trigger assembly **70** may be designed such that the monopolar element **154** may be extended when the jaw members **110** and **120** are in the open position. For example, the trigger **71** may be moved distally (or upwardly) from its original, rested, neutral or pre-actuated position to advance the monopolar element **154**. Alternatively, the monopolar element **154** may be advanced irrespective of the orientation of the jaw members **110** and **120**. For example, the trigger assembly **70** could be designed such that it can be moved laterally (i.e., perpendicular to the longitudinal axis "A") to advance the monopolar element **154** or the trigger assembly **70** could be designed such that the monopolar element **154** is extendible when the trigger **71** is moved to a proximal-most position (i.e., past the "cut" position as described above) and/or when the trigger **71** is advanced distally from the neutral or pre-actuated orientation. A return spring (not shown) may be included to return the monopolar element **154** to a non-extended position upon release of the trigger **71**.

Upon extension of the monopolar element **154**, the generator **300** is preferably configured to automatically switch the forceps **10** from a bipolar activation mode (i.e., deactivating energy delivery to jaw members **110** and **120**) to a monopolar activation mode (i.e., activating the monopolar element **154**). As can be appreciated, the forceps **10** may also (or alternatively) be configured for manual switching between the bipolar activation mode and the monopolar activation mode.

As described above, when the forceps **10** is configured for bipolar operation, the activation of switch **200** transfers energy from jaw member **110** through the tissue and to jaw member **120** to treat tissue. In the monopolar mode, activation of switch **200** (or a separate switch, e.g., a footswitch), transfers energy to the monopolar element **154**, through the tissue and to a return electrode **550**, e.g., a return pad, placed adjacent to or in contact with the patient. The monopolar activation mode allows the monopolar element **154** to quickly treat avascular tissue structures and/or quickly dissect narrow tissue planes.

As can be appreciated, it is also envisioned that the trigger assembly **70** may be electrically configured to transmit electrical energy to the monopolar element **154** when extended. For example, the trigger assembly **70** may be

configured such that proximal-most actuation of the trigger 71 (FIG. 1C) both extends and activates the monopolar element 154. An automatic safety circuit 460 (or mechanical safety lock (not shown)) may be employed which prevents the switch 200 from energizing the jaw members 110 and 120 when the monopolar element 154 is extended.

FIG. 4 shows another embodiment of the present disclosure wherein the monopolar element 154 is selectively extendible utilizing a second actuator 450. As described above, the knife 185 is advanced by actuating the trigger 71 in a generally proximal direction. The monopolar element 154 is selectively advanceable independently of the knife 185 and may be extended when the jaw members 110 and 120 are disposed in either the open configuration or closed configuration. It is envisioned that the actuator 450 may be electrically configured to activate the monopolar element 154 automatically once extended or manually by activation switch 200 or perhaps another switch (not shown). As mentioned above, a safety circuit 460 may be employed to deactivate jaw members 110 and 120 when the monopolar element 154 is extended such that activation of the switch 200 energizes the monopolar element 154. In the case of a separate activation switch for the monopolar element, the safety circuit would deactivate the switch 200.

FIG. 5A-5C show an alternate embodiment of the present disclosure wherein the knife 185 can be extended distally beyond the jaw members 110 and 120 and separately energized to treat tissue. In this instance, when the knife is extended beyond the jaw members 110 and 120, the knife 185 becomes the monopolar element.

For example and as depicted in the activation sequence shown in FIGS. 5A-5C, the knife 185 is initially seated in a neutral position during tissue approximation and grasping and during the sealing process. Once the jaw members 110 and 120 are closed about tissue, the elongated knife channel 115 (defined by upper and lower knife channels 115a and 115b, respectively) is formed to allow selective translation of the knife 185 through tissue disposed between the jaw members 110 and 120. Upon actuation of the trigger 71, the knife bar 64 forces the knife 185 distally through the tissue to the distal end of the knife channel 115. A stop 119 is included to temporarily limit the movement of the knife 185 and provide the user with positive tactile feedback as to the end of the cutting stroke. Upon further actuation of the trigger 71, the knife 185 overcomes the limiting forces associated with the stop 119 and is forced by the knife bar to further extend out of the knife channel 115 and beyond the distal ends of the jaw members 110 and 120.

It is envisioned that once the knife 185 extends beyond the jaw members 110 and 120, a safety or switch deactivates energizing circuitry to the jaw members 110 and 120 and activates the energizing circuitry to the knife 185 such that activation of the switch 200 energizes the knife 185 and the jaw members remain neutral. For example, the stop 119 may act as a safety switch such that upon being forced by the knife 185 out of or away from the knife channel 115, the stop 119 deactivates circuitry to the jaw members 110 and 120 and activates circuitry to the monopolar knife 185 and the return electrode 550. A separate lead 69 may be used to electrically communicate with the generator 300. As can be appreciated, the knife 185 may now be used in a monopolar fashion to treat tissue.

Upon release of the trigger 71, the knife 185 automatically retracts into the knife channel 115 and back to the pre-actuated position as shown in FIG. 5A. At the same time the stop 119 reverts to its original position to temporarily block the knife channel 115 for subsequent actuation.

FIG. 6A shows another embodiment of a forceps 10' according to the present disclosure wherein the lower jaw member 120' is designed to extend beyond the distal end of jaw member 110'. In order to switch from a bipolar mode of the operation to a monopolar mode, the surgeon activates a switch or control which energizes jaw member 120' to a first potential and activates a return pad 550 to a second potential. Energy is transferred from jaw member 120, through tissue, and to the return pad 550 to treat tissue. The distal end of jaw member 120' acts as the monopolar element for treating the tissue and may be shaped accordingly to enhance electro-surgical effect.

FIG. 6B shows yet another schematic embodiment of a forceps 10'' according to the present disclosure wherein the distal ends of both jaw members 110 and 120 are shaped to treat tissue when disposed in a monopolar mode. More particularly, the distal tips 112a'' and 122a'' are preferably elongated or tapered to enhance energy delivery when the forceps 10'' is disposed in the monopolar mode. When disposed in the bipolar mode, the tapered ends 112a'' and 122a'' do not effect treating tissue between electrically conductive plates 112'' and 122''.

A control switch 500 is preferably included which regulates the transition between bipolar mode and monopolar mode. Control switch 500 is connected to generator 300 via cables 360 and 370. A series of leads 510, 520 and 530 are connected to the jaw members 110, 120 and the return electrode 550, respectively. As best shown in the table depicted in FIG. 6C, each lead 510, 520, and 530 is provided with an electrical potential or remains neutral depending upon the particular "mode" of the forceps 10''. For example, in the bipolar mode, lead 510 (and, in turn, jaw member 110'') is energized with a first electrical potential and lead 520 (and, in turn, jaw member 120'') is energized with second electrical potential. As a result thereof, electro-surgical energy is transferred from jaw member 110'' through the tissue and to jaw member 120''. The return electrode 550 remains off or neutral.

In a monopolar mode, jaw member 110'' and 120'' are both energized with the same electrical potential and the return pad 550 is energized with a second electrical potential forcing the electrical current to travel from the jaw members 110'' and 120'', through the tissue and to the return electrode 550. This enables the jaw members 110'' and 120'' to treat tissue in a monopolar fashion which, as mentioned above, advantageously treats avascular tissue structures and/or allows quick dissection of narrow tissue planes. As can be appreciated, all of the leads 510, 520 and 530 may be deactivated when the forceps 10'' is turned off or idle.

Although the general operating components and inter-cooperating relationships among these components have been generally described with respect to a vessel sealing forceps 10, other instruments may also be utilized which can be configured to allow a surgeon to selectively treat tissue in both a bipolar and monopolar fashion. For example, bipolar grasping and coagulating instruments, cauterizing instruments, bipolar scissors, etc.

The present disclosure also relates to a method for treating tissue with electro-surgical energy from the electro-surgical generator 300 which includes the steps of: providing an endoscopic forceps 10 including a housing 20 having a shaft 12 affixed thereto. The shaft 12 includes first and second jaw members, 110 and 120, respectively, attached to a distal end of the shaft 12. An actuator or handle assembly 30 is included for moving jaw members 110 and 120 relative to one another from a first position wherein the jaw members 110 and 120 are disposed in spaced relation relative to one

another to a second position wherein the jaw members **110** and **120** cooperate to grasp tissue therebetween. A monopolar element **154** is also included which is housed within at least the first jaw member **120** and selectively movable from a first position within the first jaw member **120** to a second position distal to the first jaw member **120**. A return electrode **550** is provided and placed in contact with patient tissue.

The method also includes the steps of: connecting to each jaw member **110** and **120**, the monopolar element **154** and the return electrode **550** to the electrosurgical generator **300**; grasping tissue between the jaw members **110** and **120**; selectively activating the jaw members **110** and **120** to treat tissue disposed between the jaw members **110** and **120** in a bipolar fashion; and selectively activating the monopolar element **154** and the return electrode **550** independent of the jaw members **110** and **120** to treat tissue in a monopolar fashion.

Preferably, after the step of selectively activating the jaw members **110** and **120** to treat tissue, the method includes the step of: extending the monopolar element **154** from the distal end of the jaw members **110** and **120**. Advantageously, the step of selectively activating the monopolar element **154** includes deactivating the jaw members **110** and **120**.

After the step of selectively activating the jaw members **110** and **120** to treat tissue, the method may include the step of: releasing the tissue from the jaw members **110** and **120**.

From the foregoing and with reference to the various figure drawings, those skilled in the art will appreciate that certain modifications can also be made to the present disclosure without departing from the scope of the same. For example, it may be preferable to add other features to the forceps **10**, e.g., an articulating assembly to axially displace the end effector assembly **100** relative to the elongated shaft **12**.

It is envisioned that the forceps **10** may be designed such that it is fully or partially disposable depending upon a particular purpose or to achieve a particular result. For example, end effector assembly **100** may be selectively and releasably engageable with the distal end **16** of the shaft **12** and/or the proximal end **14** of shaft **12** may be selectively and releasably engageable with the housing **20** and the handle assembly **30**. In either of these two instances, the forceps **10** would be considered "partially disposable" or "reposable", i.e., a new or different end effector assembly **100** (or end effector assembly **100** and shaft **12**) selectively replaces the old end effector assembly **100** as needed. As can be appreciated, the presently disclosed electrical connections would have to be altered to modify the instrument to a reposable forceps.

Moreover, it is envisioned that the switch **200** may be decommissioned during the cutting process. Decommissioning the switch **200** when the trigger **71** is actuated eliminates unintentionally activating the forceps during the cutting process. It is also envisioned that the switch **200** may be disposed on another part of the forceps **10**, e.g., the fixed handle **40**, rotating assembly **80**, housing **20**, etc.

While several embodiments of the disclosure have been shown in the drawings, it is not intended that the disclosure be limited thereto, as it is intended that the disclosure be as broad in scope as the art will allow and that the specification be read likewise. Therefore, the above description should not be construed as limiting, but merely as exemplifications of preferred embodiments. Those skilled in the art will envision other modifications within the scope and spirit of the claims appended hereto.

What is claimed is:

1. An endoscopic forceps, comprising:

a housing having a shaft affixed thereto, the shaft including first and second jaw members attached to a distal end thereof;

an actuator for moving jaw members relative to one another from a first position wherein the jaw members are disposed in spaced relation relative to one another to a second position wherein the jaw members cooperate to grasp tissue therebetween;

a source of electrosurgical energy connected to each jaw member such that the jaw members are selectively capable of operating in a bipolar mode which enables the jaw members to conduct bipolar energy through tissue held therebetween to treat tissue; and

a monopolar element housed within at least the first jaw member and selectively movable from a first position within the first jaw member to a second position distal to the first jaw member, the monopolar element being connected to the source of electrosurgical energy and being selectively activateable independent of the jaw members.

2. An endoscopic forceps according to claim 1 wherein the monopolar element includes a sharpened cutting edge.

3. An endoscopic forceps according to claim 1 wherein the forceps includes a knife which is selectively moveable within a knife channel defined within at least one of the first and second jaw members to cut tissue disposed between the first and second jaw members.

4. An endoscopic forceps according to claim 1 wherein the forceps is a vessel sealing forceps and at least one of the jaw members includes at least one non-conductive stop member disposed thereon which controls the distance between the first and second jaw members when tissue is held therebetween.

5. An endoscopic forceps according to claim 1 wherein the monopolar element is a knife which is selectively moveable within a knife channel defined within at least one of the first and second jaw members to initially cut tissue disposed between the first and second jaw members and subsequently extend distally from the jaw members, the knife being energized to treat tissue in a monopolar fashion.

6. An endoscopic forceps according to claim 5 wherein the knife includes a safety which only allows electrical activation of the knife when the knife is extended from the distal ends of the jaw members.

7. An endoscopic forceps according to claim 3 further comprising a trigger operable to both move the knife to divide tissue disposed between the jaw members and to extend the monopolar element from the first position within the first jaw member to the second position distal to the first jaw member.

8. An endoscopic forceps according to claim 1 wherein the actuator operates to both move the jaw members relative to one another from the first to second positions to grasp tissue therebetween and the actuator operates to extend the monopolar element from the first position within the first jaw member to the second position distal to the first jaw member.

9. An endoscopic forceps according to claim 1 further comprising a second actuator which operates to extend the monopolar element from the first position within the first jaw member to the second position distal to the first jaw member.

10. A method for treating tissue with electrosurgical energy from an electrosurgical generator, the method comprising the steps of:

17

providing an endoscopic forceps comprising:

a housing having a shaft affixed thereto, the shaft including first and second jaw members attached to a distal end thereof;
 an actuator for moving jaw members relative to one another from a first position wherein the jaw members are disposed in spaced relation relative to one another to a second position wherein the jaw members cooperate to grasp tissue therebetween;
 a monopolar element housed within at least the first jaw member and selectively movable from a first position within the first jaw member to a second position distal to the first jaw member; and
 a return electrode placed in contact with patient tissue; connecting each jaw member, the monopolar element and the return electrode to the electrosurgical generator;
 grasping tissue between the jaw members;
 selectively activating the jaw members to treat tissue disposed between the jaw members in a bipolar fashion; and

18

selectively activating the monopolar element and the return electrode independent of the jaw members to treat tissue in a monopolar fashion.

11. A method according to claim **10** wherein after the step of selectively activating the jaw members to treat tissue, the method includes the step of:

extending the monopolar element from the distal end of the jaw members.

12. A method according to claim **10** wherein the step of selectively activating the monopolar element includes deactivating the jaw members.

13. A method according to claim **10** wherein after the step of selectively activating the jaw members to treat tissue, the method includes the step of:

releasing the tissue from the jaw members.

* * * * *