

US007362864B2

(12) **United States Patent**
Kryzak et al.

(10) **Patent No.:** **US 7,362,864 B2**
(45) **Date of Patent:** **Apr. 22, 2008**

(54) **FRAMING OF TRANSMIT ENCODED DATA AND LINEAR FEEDBACK SHIFTING**

(75) Inventors: **Joseph Neil Kryzak**, Ames, IA (US);
Aaron J. Hoelscher, Ankeny, IA (US)

(73) Assignee: **Xilinx, Inc.**, San Jose, CA (US)

(*) Notice: Subject to any disclaimer, the term of this patent is extended or adjusted under 35 U.S.C. 154(b) by 870 days.

(21) Appl. No.: **10/659,979**

(22) Filed: **Sep. 11, 2003**

(65) **Prior Publication Data**

US 2005/0058290 A1 Mar. 17, 2005

(51) **Int. Cl.**
H04L 9/00 (2006.01)

(52) **U.S. Cl.** **380/268**; 380/261; 380/260

(58) **Field of Classification Search** 380/268,
380/255, 265, 260, 261
See application file for complete search history.

(56) **References Cited**

U.S. PATENT DOCUMENTS

4,667,305 A 5/1987 Dill et al.
5,561,714 A 10/1996 Hershberger
5,659,718 A 8/1997 Osman et al.

FOREIGN PATENT DOCUMENTS

EP 1 133 124 A2 9/2001

OTHER PUBLICATIONS

Key distribution scheme based on two cryptosystems for hierarchical access control Bing Hu; Wu Ye; Sui-Li Feng; Xiao-Liang Wang;

Xing Xie; Advanced Communication Technology, 2006. ICACT 2006. The 8th International Conference vol. 3, Feb. 20-22, 2006.*

Scrambling and key distribution scheme for digital television Kanjanarin, W.; Amornraksa, T.; Networks, 2001. Proceedings. Ninth IEEE International Conference on Oct. 10-12, 2001 pp. 140-145.*

On Compression of Encrypted Video Schonberg, D.; Chuohao Yeo; Draper, S.C.; Ramchandran, K.; Data Compression Conference, 2007. DCC '07 Mar. 27-29, 2007 pp. 173-182.*

(Continued)

Primary Examiner—David Jung

(74) *Attorney, Agent, or Firm*—Timothy W. Markison; LeRoy D. Maunu

(57) **ABSTRACT**

Framing transmit encoded output data begins by determining a scrambling remainder between scrambling of an input code word in accordance with a 1st scrambling protocol and the scrambling of the input code word in accordance with an adjustable scrambling protocol. The processing continues by adjusting the adjustable scrambling protocol based on the scrambling remainder to produce an adjusted scrambling protocol. The processing continues by scrambling the input code word in accordance with the 1st scrambling protocol to produce a 1st scrambled code word. The processing continues by scrambling the input code word in accordance with the adjusted scrambling protocol to produce a scrambled partial code word. The processing continues by determining a portion of the 1st scrambled code word based on the scrambling remainder. The process continues by combining the scrambled partial code word with the portion of the 1st scrambled code word to produce the transmit encoded output data.

22 Claims, 10 Drawing Sheets

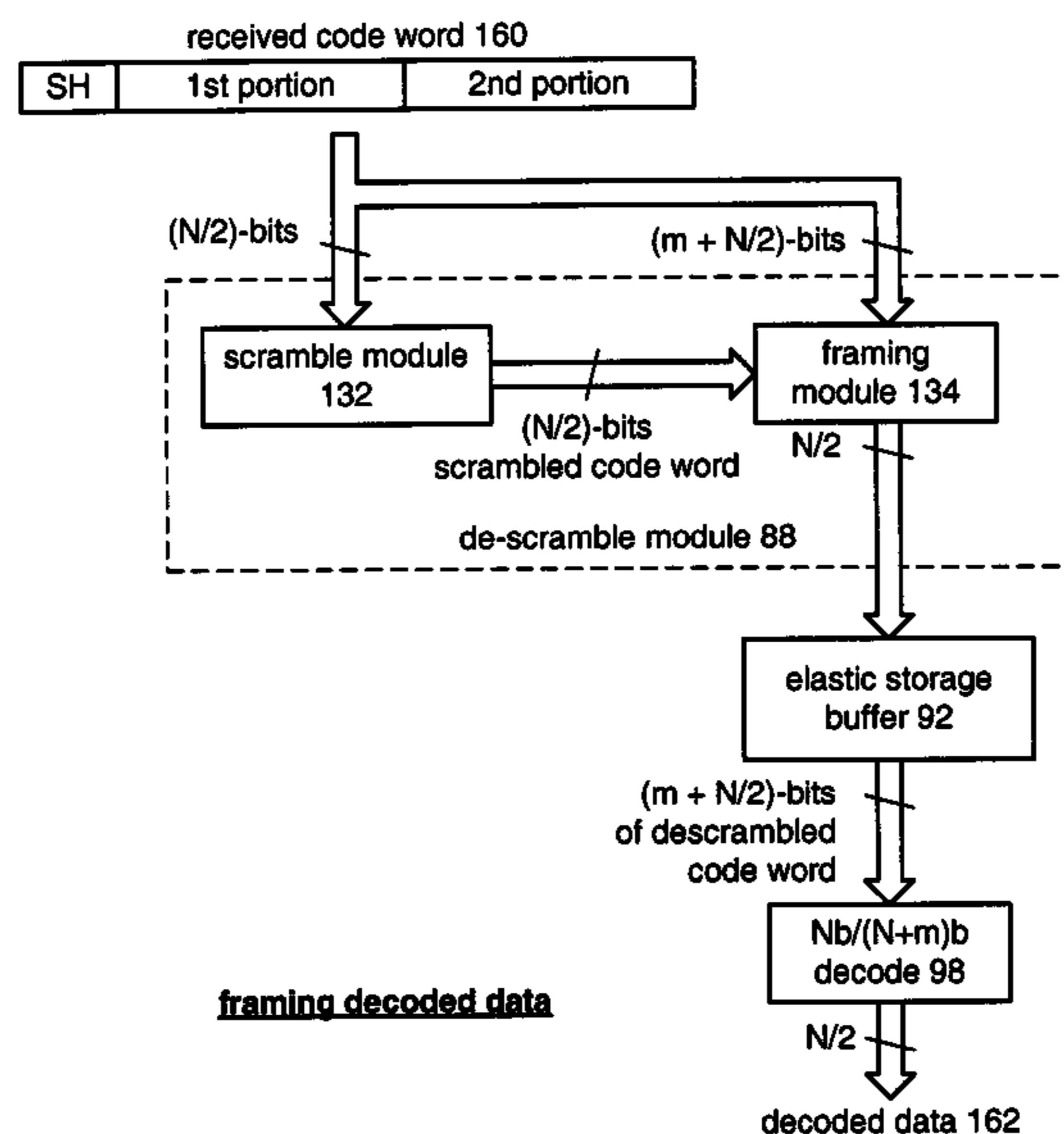

OTHER PUBLICATIONS

Encrypted video over TETRA Samarakoon, M.I.; Honary, B.; Rayne, M.; Tetra Market and Technology Developments (Ref. No. 2000/007), IEE Seminar on Feb. 10, 2000 pp. 3/1-3/5.*

A fast video encryption scheme suitable for network applications Shiguo Lian; Zhiqian Wang; Jinsheng Sun; Communications, Circuits and Systems, 2004. ICCAS 2004. 2004 International Conference on vol. 1, Jun. 27-29, 2004 pp. 566-570 vol. 1.*

U.S. Appl. No. 10/660,234, filed Sep. 11, 2003, Boecker.

U.S. Appl. No. 10/660,449, filed Sep. 11, 2003, Cory et al.

U.S. Appl. No. 10/660,191, filed Sep. 11, 2003, Kryzak et al.

U.S. Appl. No. 10/660,062, filed Sep. 11, 2003, Groen et al.

U.S. Appl. No. 10/660,448, filed Sep. 11, 2003, Groen et al.

U.S. Appl. No. 10/659,803, filed Sep. 11, 2003, Black et al.

U.S. Appl. No. 10/659,819, filed Sep. 11, 2003, Groen et al.

U.S. Appl. No. 10/659,971, filed Sep. 11, 2003, Boecker et al.

U.S. Appl. No. 10/660,254, filed Sep. 11, 2003, Groen et al.

U.S. Appl. No. 10/661,016, filed Sep. 11, 2003, Groen et al.

U.S. Appl. No. 10/659,972, filed Sep. 11, 2003, Shafer.

U.S. Appl. No. 10/659,974, filed Sep. 11, 2003, Kryzak et al.

U.S. Appl. No. 10/660,159, filed Sep. 11, 2003, Groen et al.

U.S. Appl. No. 10/660,016, filed Sep. 11, 2003, Jenkins.

U.S. Appl. No. 10/659,973, filed Sep. 11, 2003, Groen et al.

U.S. Appl. No. 10/660,190, filed Sep. 11, 2003, Groen.

U.S. Appl. No. 10/659,916, filed Sep. 11, 2003, Black et al.

U.S. Appl. No. 10/659,978, filed Sep. 11, 2003, Groen et al.

U.S. Appl. No. 10/660,235, filed Sep. 11, 2003, Boecker et al.

U.S. Appl. No. 10/659,966, filed Sep. 11, 2003, Chuang et al.

U.S. Appl. No. 10/660,243, filed Sep. 11, 2003, Shafer et al.

* cited by examiner

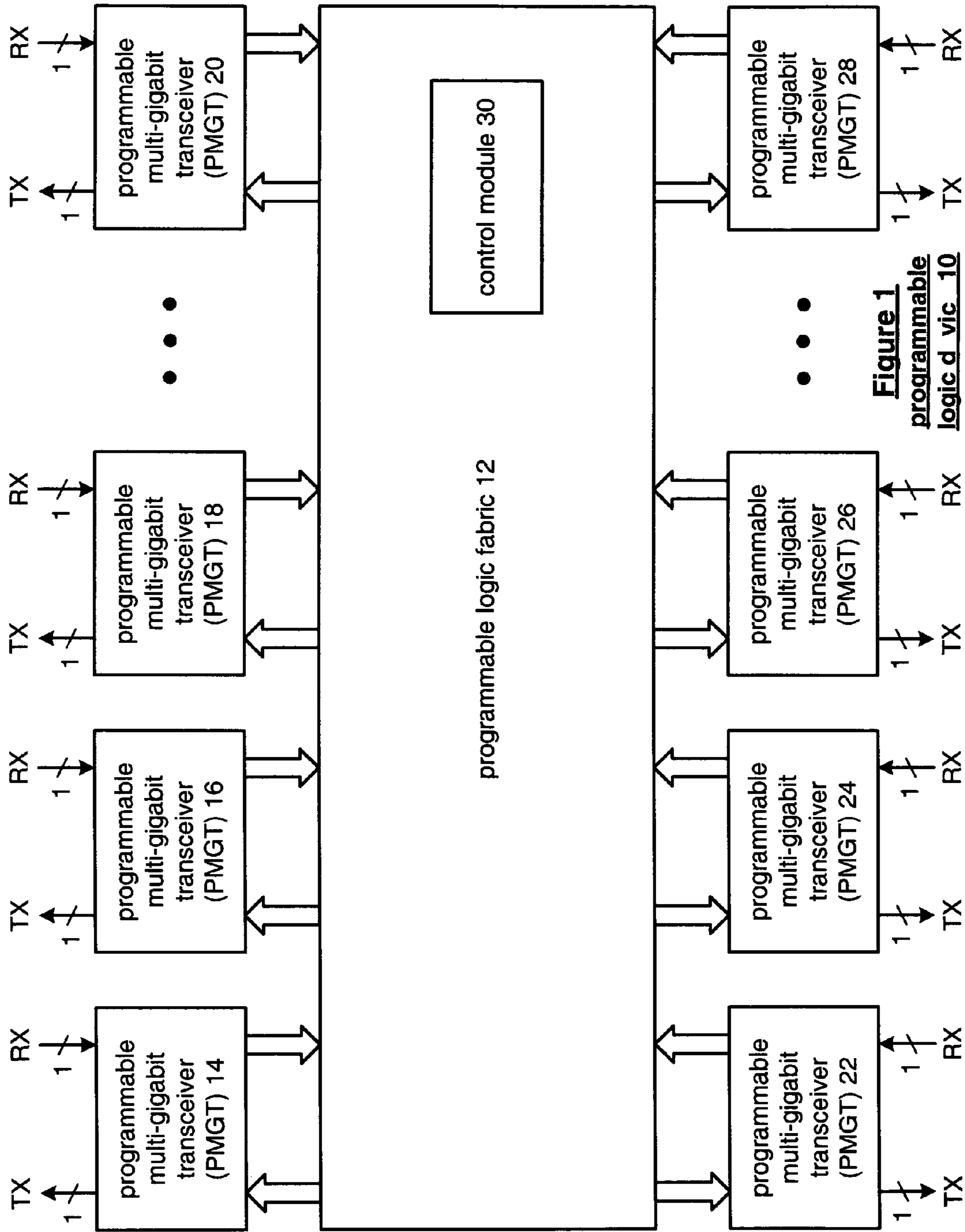

Figure 1
programmable
logic d vic 10

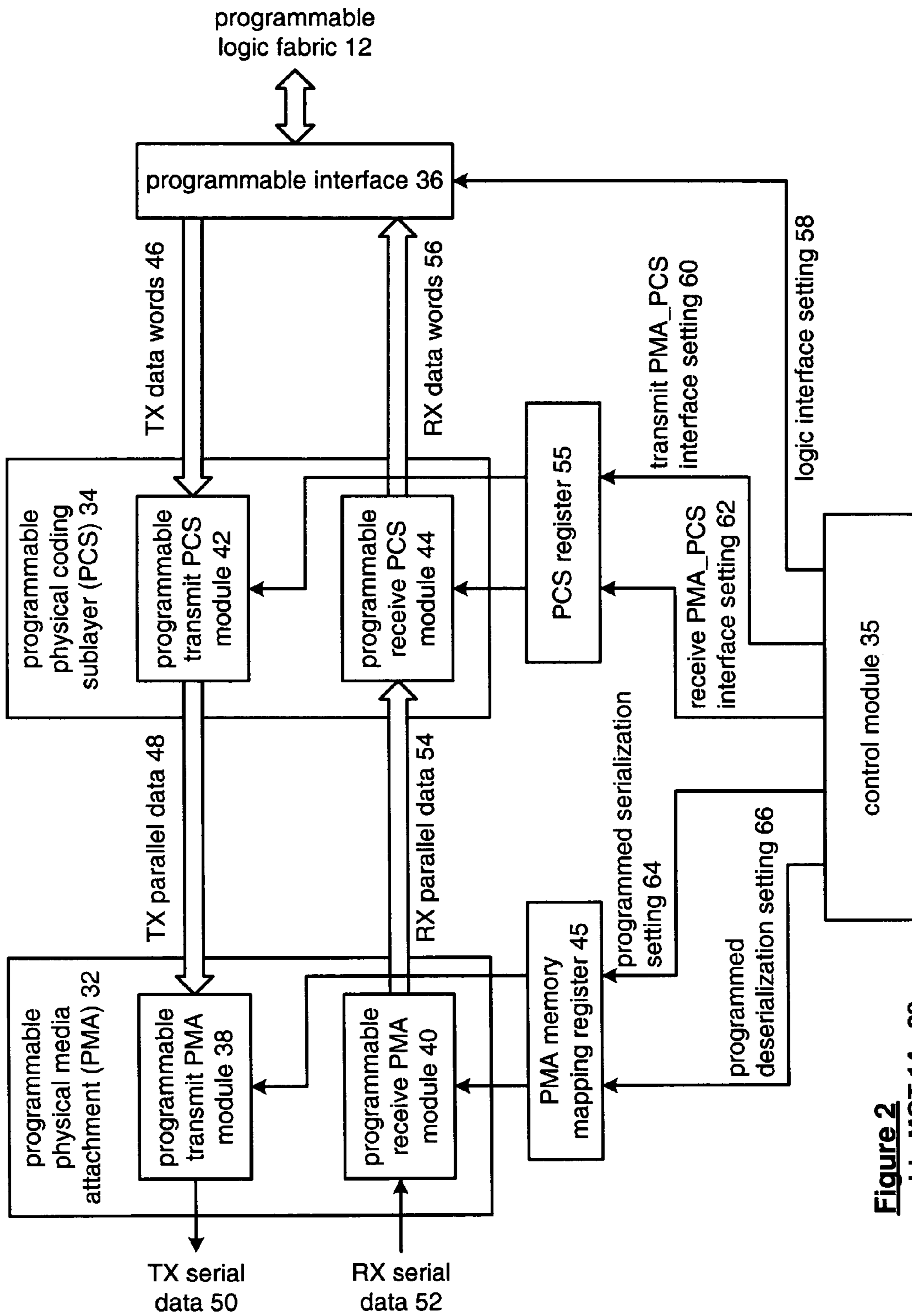

Figure 2
programmable MGT 14 - 28

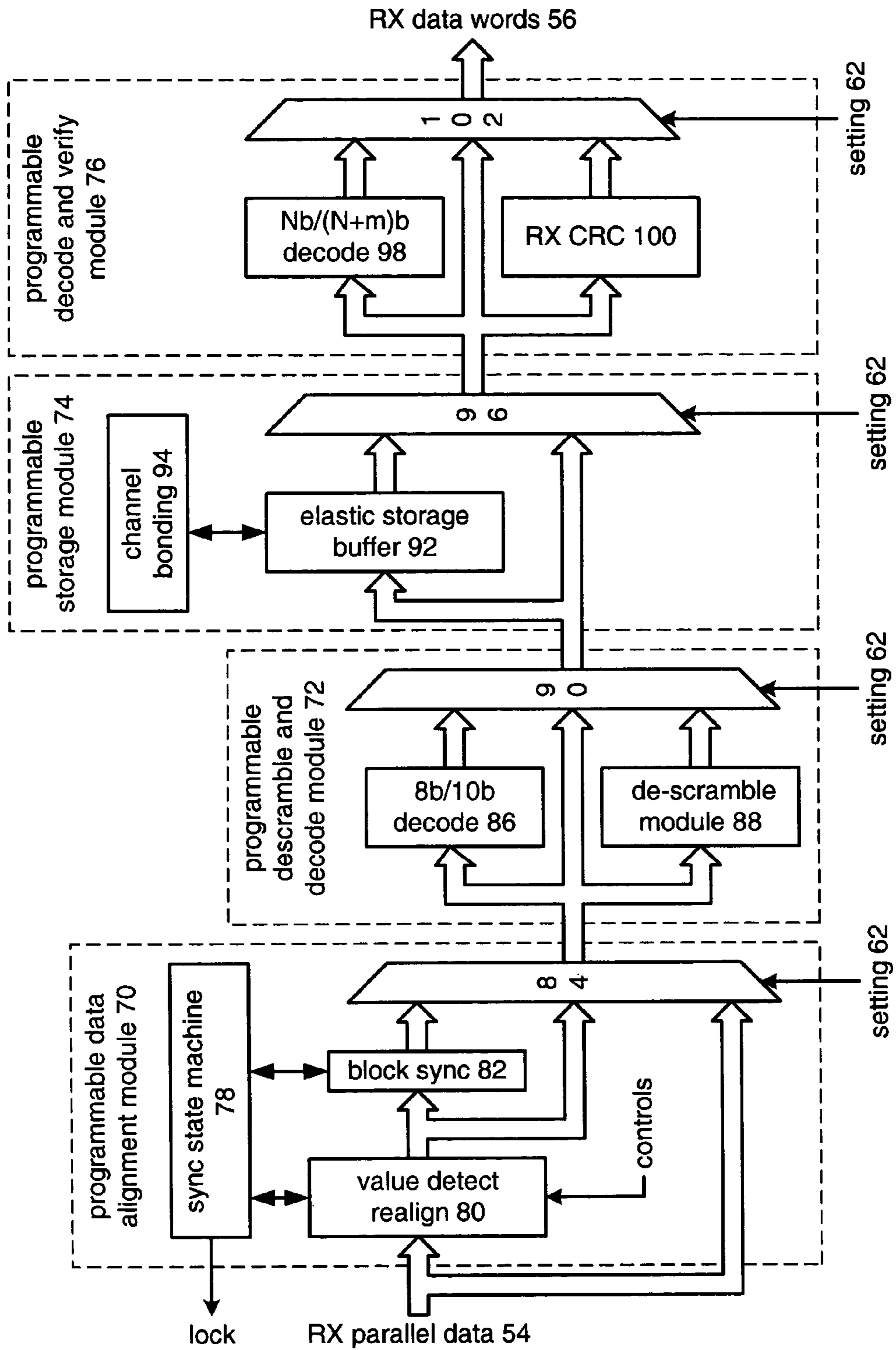

Figure 3
programmable receiver PCS
module 44

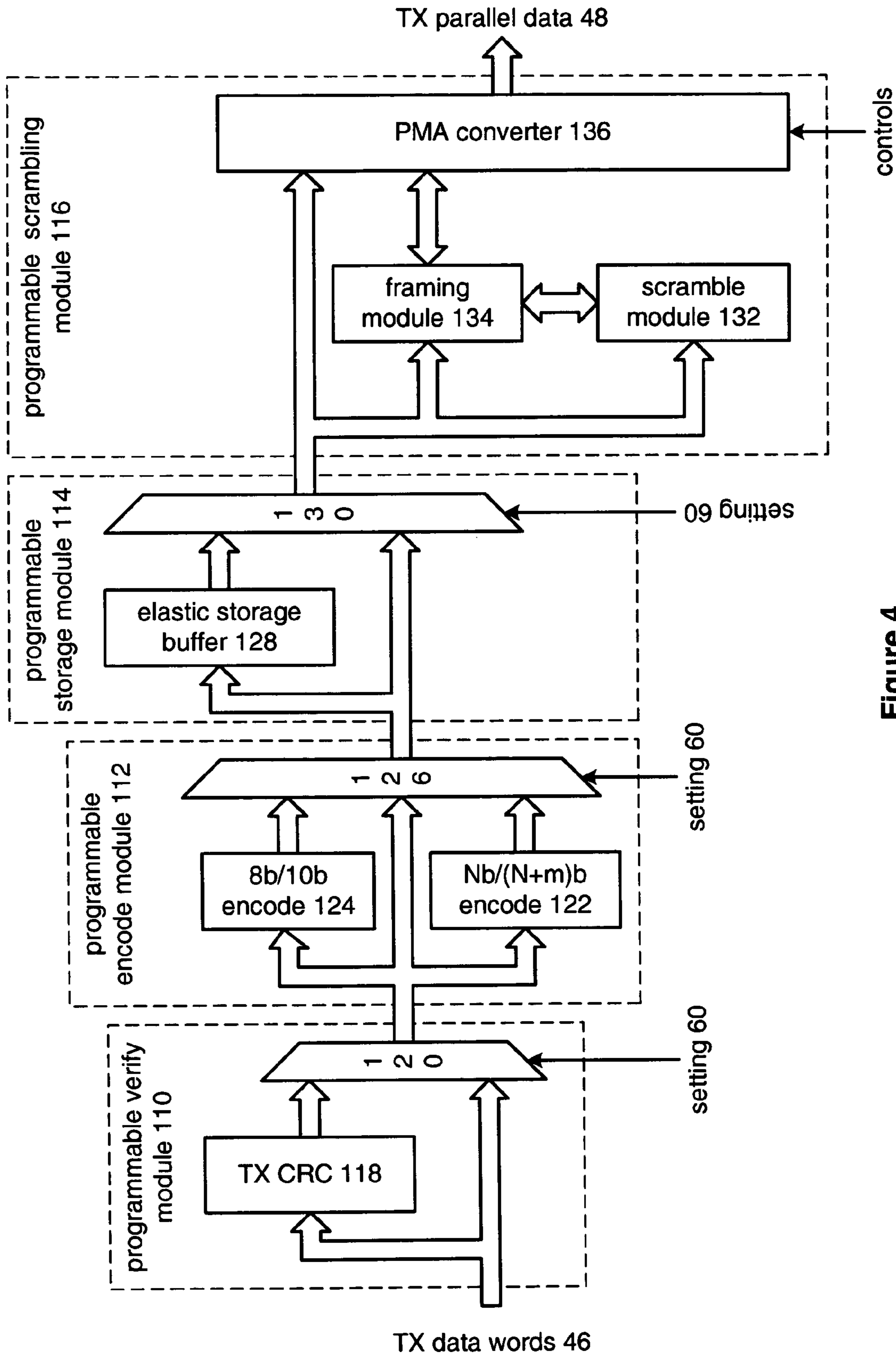

Figure 4
programmable transmit PCS module 42

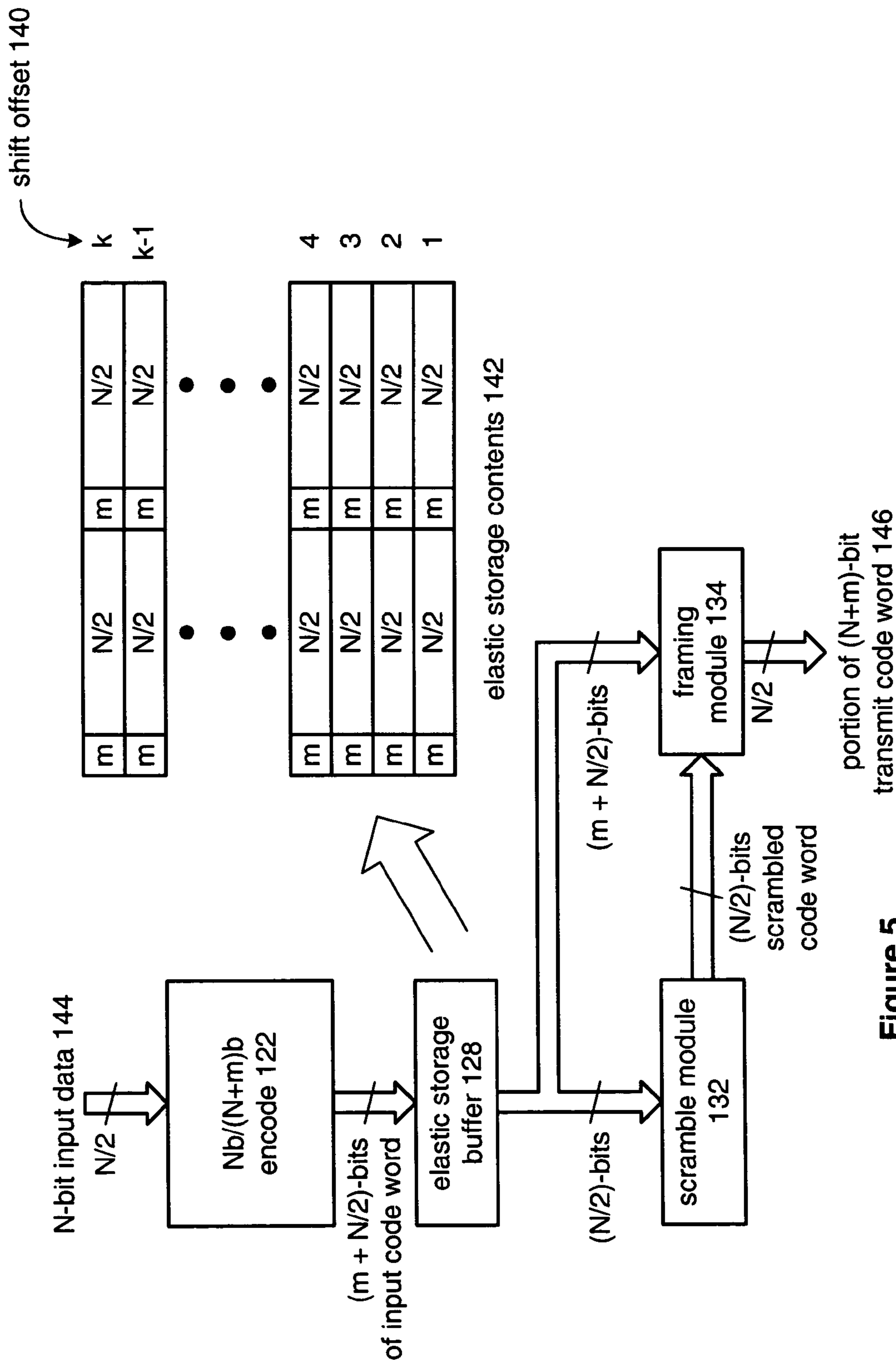
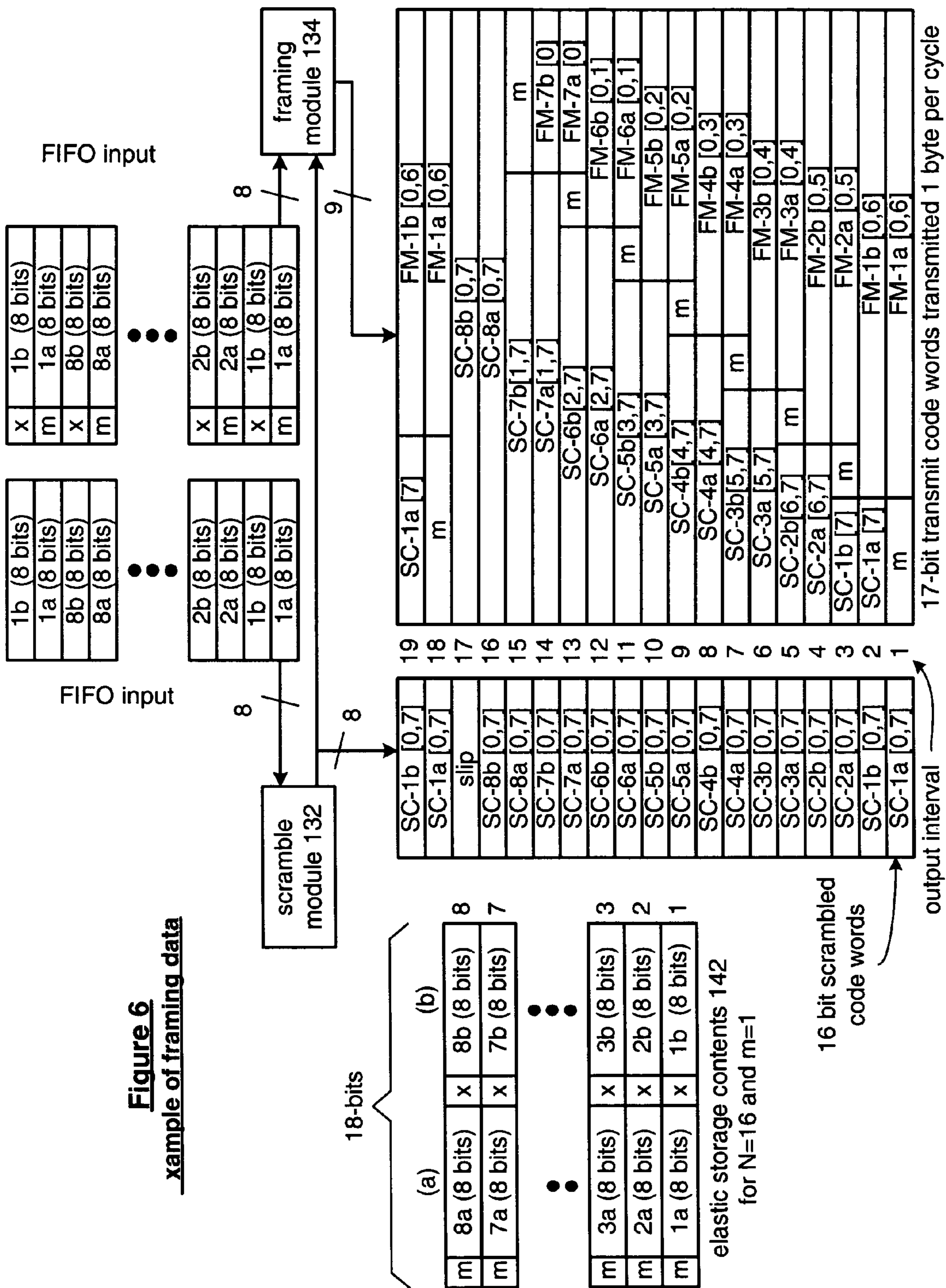

Figure 5
framing_ncod_d data



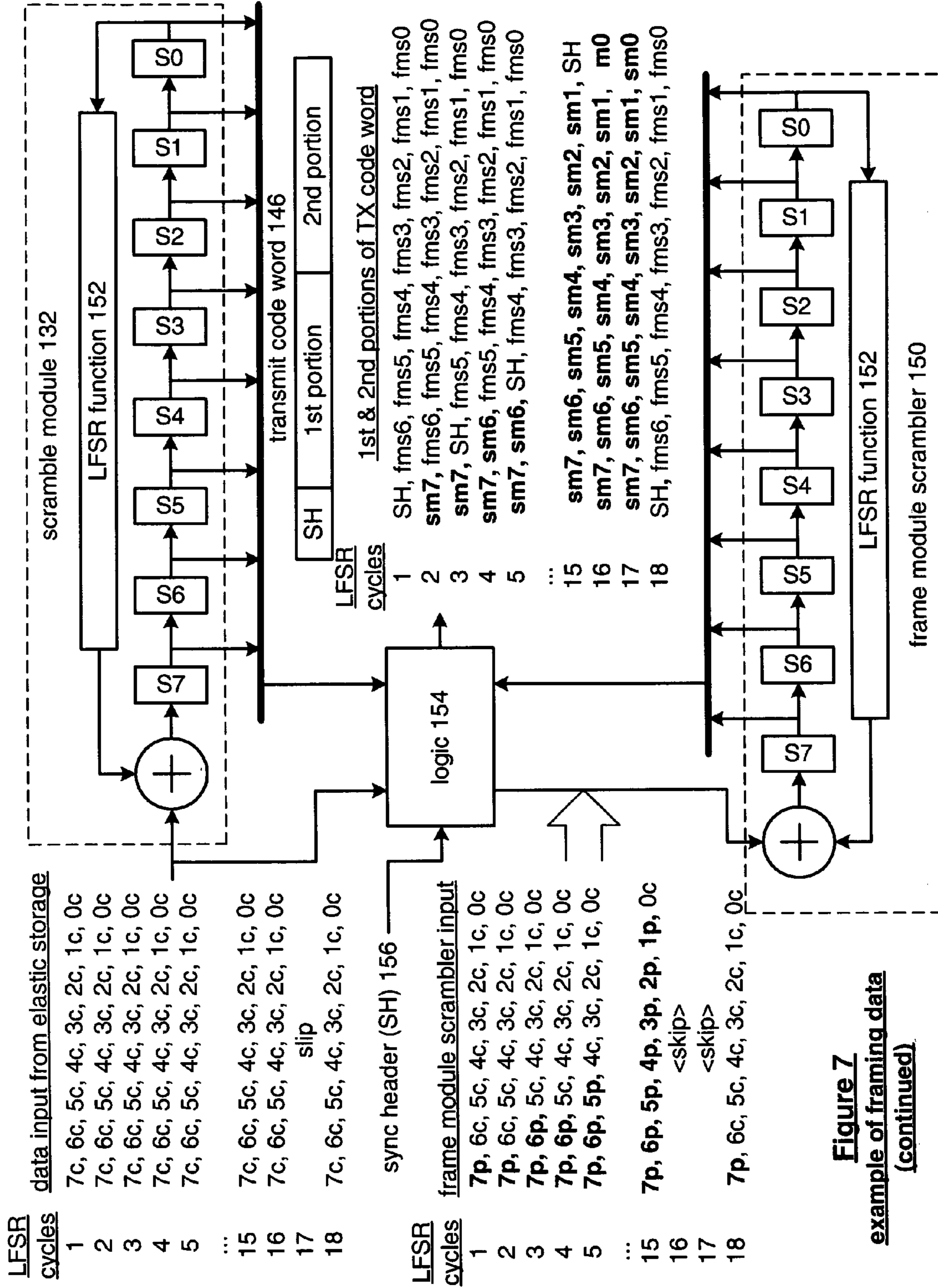

Figure 7
example of framing data
(continued)

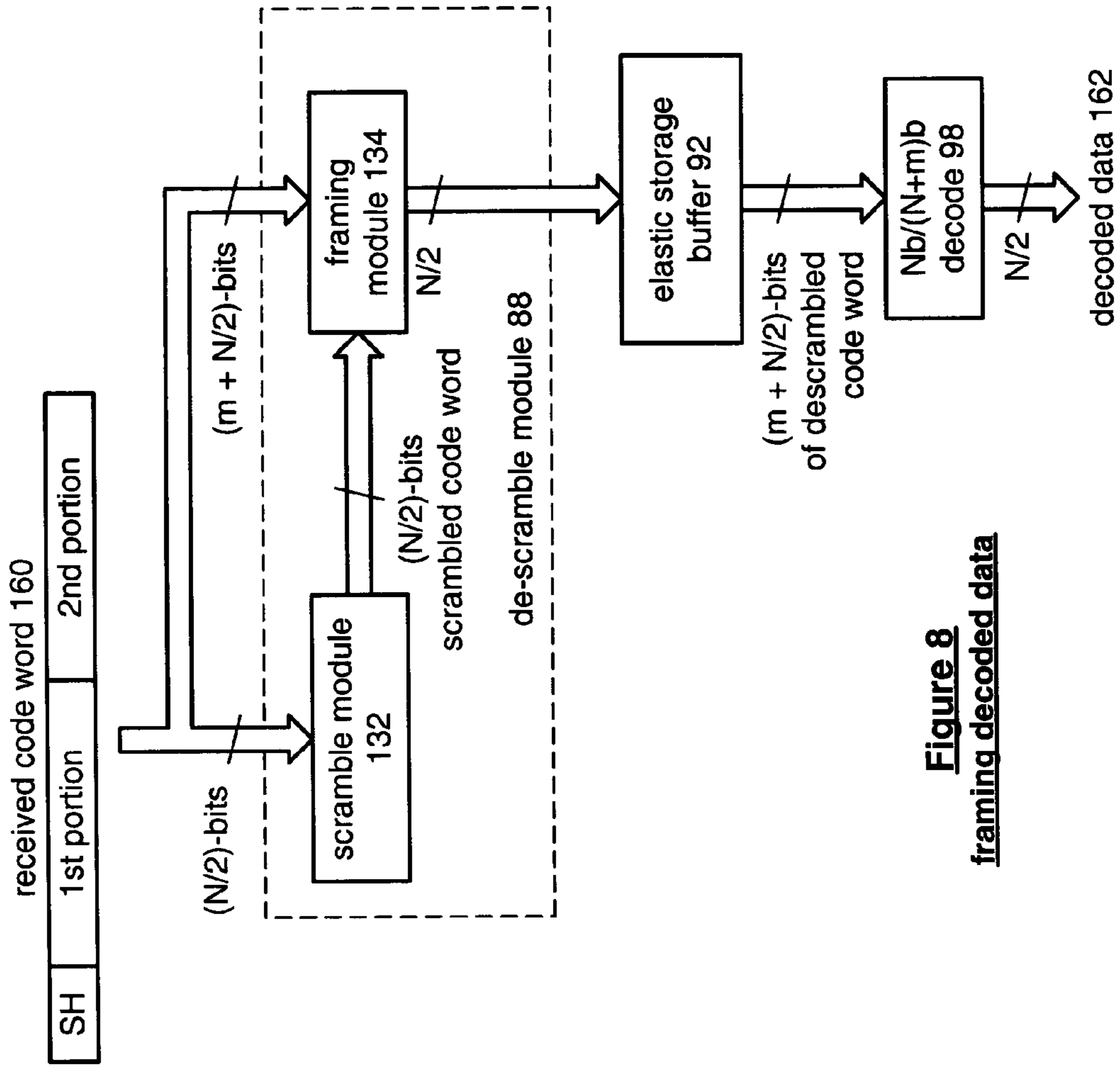

Figure 8
framing decoded data

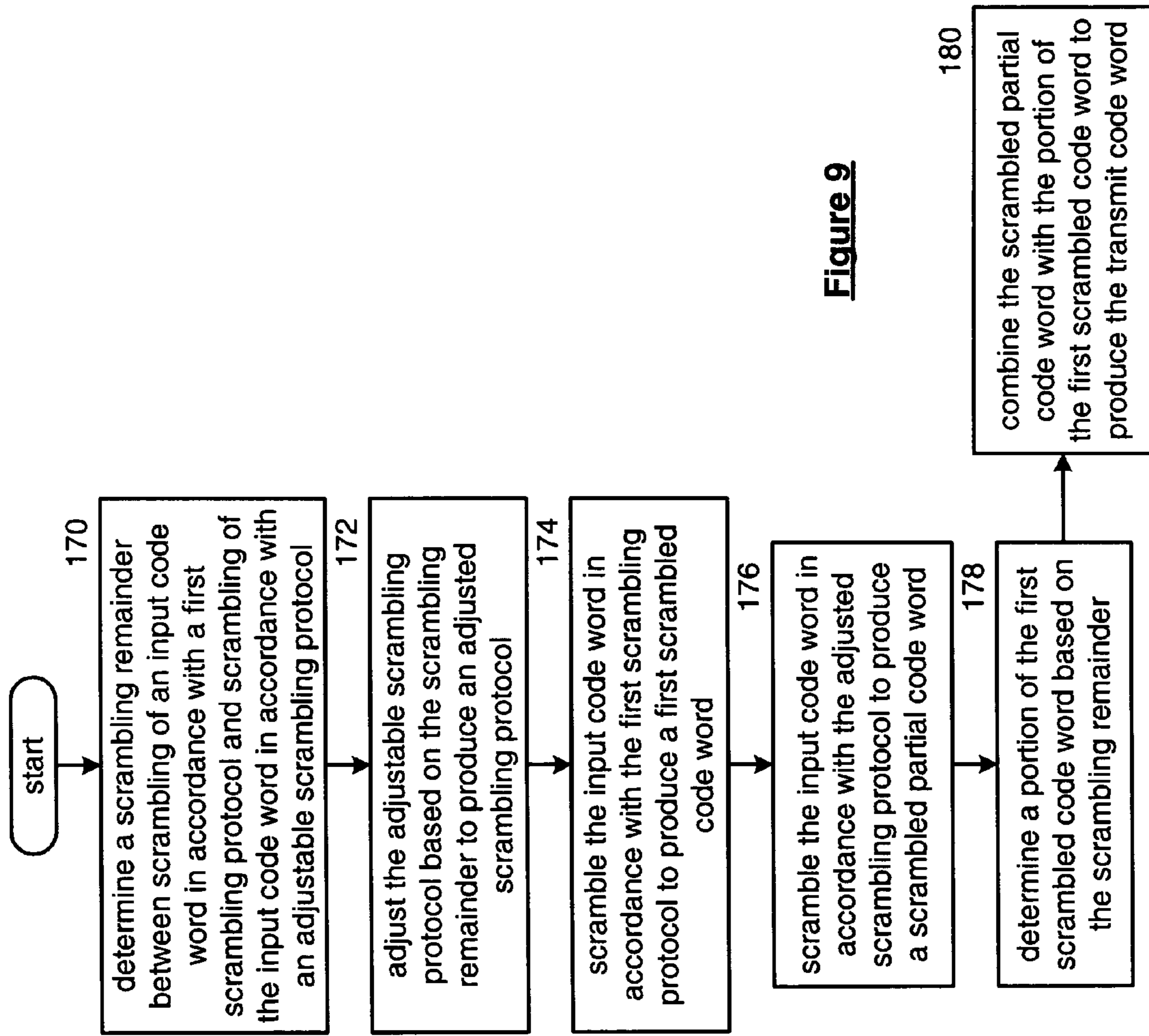

Figure 9

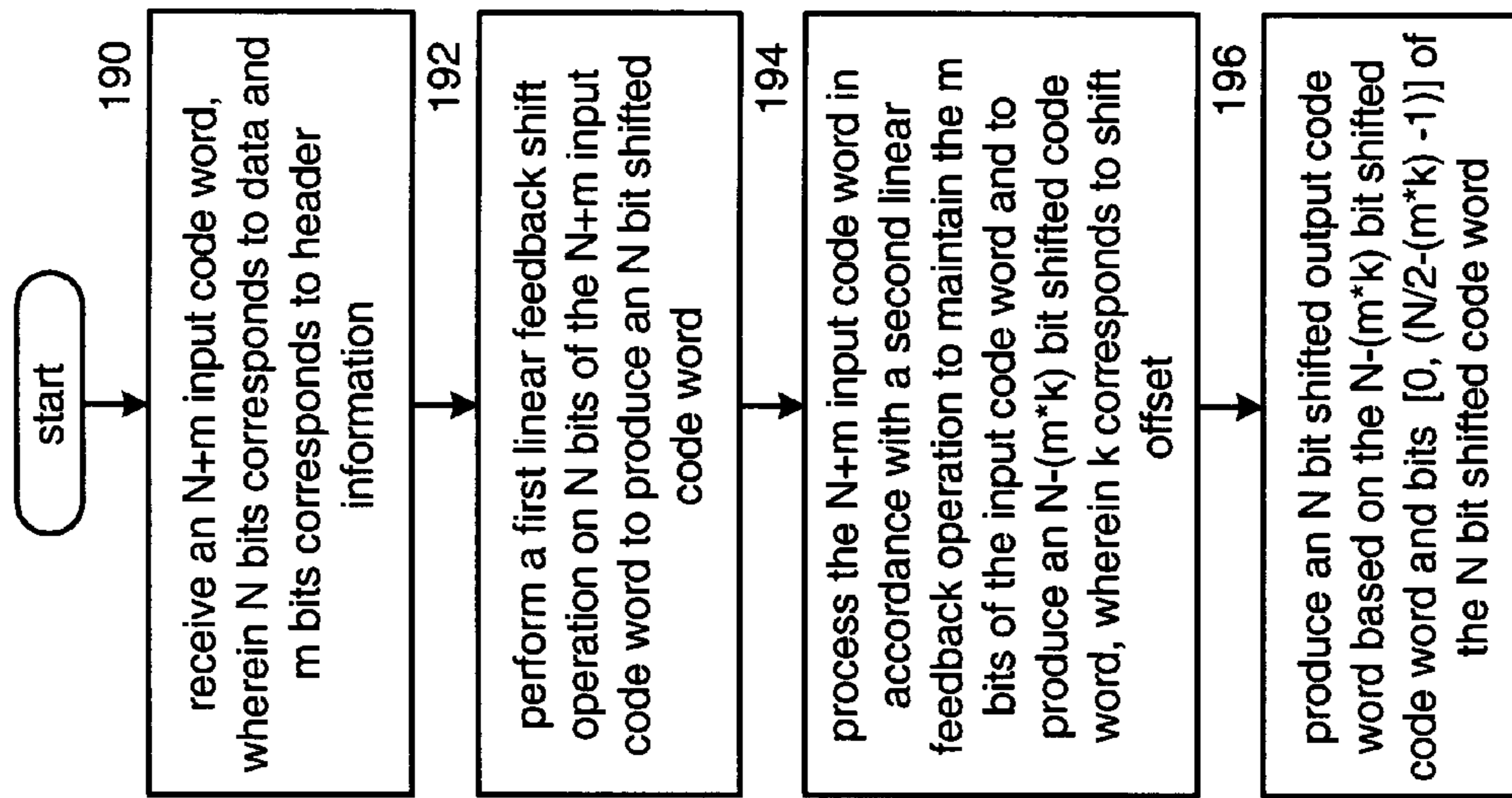

Figure
10

FRAMING OF TRANSMIT ENCODED DATA AND LINEAR FEEDBACK SHIFTING

BACKGROUND OF THE INVENTION

1. Technical Field of the Invention

This invention relates generally to communication systems and more particularly to encoding/decoding and scrambling/descrambling of data within such communication systems.

2. Description of Related Art

Communication systems are known to transport large amounts of data between a plurality of end user devices. Such end user devices include telephones, facsimile machines, computers, television sets, cellular phones, personal digital assistants, et cetera. As is also known, such communication systems may be local area networks (LAN) and/or wide area networks (WAN). A local area network is generally understood to be a network that interconnects a plurality of end user devices distributed over a localized area (e.g., up to a radius of 10 kilometers). For example, a local area network may be used to interconnect workstations distributed within an office of a single building or a group of buildings, to interconnect Internet computer based equipment distributed around a factory or hospital, et cetera.

A wide area network is generally understood to be a network that covers a wide geographic area. Wide area networks include both public data networks and enterprise wide private data networks. A public data network is established and operated by a national network administrator specifically for data transmission. Such public data networks facilitate the interworkings of equipment from different manufacturers. Accordingly, standards by the ITU-T have been established for conveying data within public data networks. Currently, there are two main types of public data networks: packet switched public data networks and circuit switched public data networks. For example, the public switched telephone network is a circuit switched public data network while the Internet is a packet switched public data network. Other examples of wide area networks include integrated service digital networks (ISDN) and broadband multi-service networks.

As is further known, communication systems may be networked together to yield larger communication systems, where such networking is typically referred to as internetworking. Internetworking is achieved via internetworking units that allow communication networks using the same or different protocols to be linked together. The internetworking units may be routers, gateways, protocol converters, bridges, and/or switches.

Regardless of the type of communication system (e.g., LAN, WAN, internetworking LAN and/or WAN), each communication system employs a data conveyance protocol to ensure that data is accurately conveyed within the system. All such data conveyance protocols are based on layers 1, 2, 3, and/or 4 of the open system interconnection (OSI) seven layer reference model. As is known, the layers include a physical layer (layer 1), a data link layer (layer 2), a network layer (layer 3), a transport layer (layer 4), a session layer (layer 5), a presentation layer (layer 6), and an application layer (layer 7).

In general, a protocol is a formal set of rules and conventions that govern how each end user device and/or data terminal equipment (i.e., the infrastructure equipment of the communication system) exchanges information within the communication system. A wide variety of protocols exist, but can generally be categorized in the one of four types of

protocols: a local area network protocol, a wide area network protocol, a routing protocol, or a network protocol. Local area network protocols operate at the physical and data link layers and define communication over various local area network and media. Wide area network protocols operate at the lowest three layers of the OSI model and define communication over the various wide area media. Routing protocols are network layer protocols that are responsible for path determination and traffic switching. Network protocols are the various upper layer protocols that exist in a given protocol suite. Examples of such protocols include asynchronous transfer mode (ATM), frame relay, TCP/IP, Ethernet, et cetera. Typically, such protocols include an encoding/decoding and/or scrambling/descrambling scheme. As is known, an encoding/decoding scheme enhances the reliability of data conveyances by encoding and/or scrambling data to include extra bits with the data to produce a code word. When the code word is received by the corresponding decoder and/or descrambler, it utilizes the extra bits to determine if the data was received without error. If the data was received without error, the decoder and/or descrambler uses the extra bits to determine and subsequently correct the error.

One such coding scheme is 64b/66b, which takes 64 bits of data and produces a 66-bit code word. In addition, the 66-bit code word is scrambled to produce a scrambled 66-bit code word. The scrambled 66-bit code word includes a 2-bit sync-header and 64 bits of scrambled encoded data. An issue arises in transmitting and subsequently receiving the scrambled 66-bit code word in that most data buses are 32-bits wide. Thus, every 2 cycles, there are 2 bits leftover, which need to be transmitted during the 3rd cycle.

The current solution to resolve this issue is to use a barrel shifter gearbox. While the barrel shifter works, it is very large with respect to die area and consumes a significant amount of power. For instance, a barrel shifter for a 32-bit bus requires 16x66 registers to store and transfer the scrambled 66-bit code words. The 66 value corresponds to the number of bits in a scrambled code word and the 16 value corresponds to the pattern of the 2 leftover bits repeating every 16 cycles (e.g., 32 bit bus divided by 2 extra bits).

Therefore, a need exists for a method and apparatus for framing code words without the need for a barrel shifter.

BRIEF SUMMARY OF THE INVENTION

The framing of transmit encoded data and linear feedback shifting of the present invention substantially meets these needs and others. In one embodiment, a transmit code word is framed by determining a scrambling remainder between scrambling of an input code word in accordance with a 1st scrambling protocol and the scrambling of the input code word in accordance with an adjustable scrambling protocol. The processing continues by adjusting the adjustable scrambling protocol based on the scrambling remainder to produce an adjusted scrambling protocol. The processing then continues by scrambling the input code word in accordance with the 1st scrambling protocol to produce a 1st scrambled code word. The processing continues by scrambling the input code word in accordance with the adjusted scrambling protocol to produce a scrambled partial code word. The processing continues by determining a portion of the 1st scrambled code word based on the scrambling remainder. The process then continues by combining the scrambled partial code word with the portion of the 1st scrambled code word to produce the transmit code word. With such a

method, encoded data, i.e., code words, may be scrambled without the need for a barrel shifter by utilizing the adjustable scrambling protocol in combination with the 1st scrambling protocol.

In another embodiment, a method for linear feedback shifting begins by receiving an N+m input code word, where N-bits of the N+m bit input code word corresponds to data and m bits of the N+m input code word corresponds to header information. The processing continues by performing a 1st linear feedback shift operation on N-bits of the N+m bit input code word to produce an N-bit shifted code word. The processing continues by processing the N+m bit input code word in accordance with a 2nd linear feedback operation to maintain the m bits of the input code word and to produce an N-(m*k) bit shifted code word, where k corresponds to a shift offset. The processing then continues by producing an N bit shifted output code word based on the N-(m*k) bit shifted code word and bits [0, (N/2-(m*k)-1)] of the N bit shifted code word. With such a method, a N+m bit code word may be shifted without the need for a barrel shifter thus considerably reducing die area requirements and power consumption.

BRIEF DESCRIPTION OF SEVERAL VIEWS OF THE DRAWINGS

FIG. 1 is a schematic block diagram of a programmable logic device in accordance with the present invention;

FIG. 2 is a schematic block diagram of a programmable multi-gigabit transceiver in accordance with the present invention;

FIG. 3 is a schematic block diagram of a programmable receive physical coding sub-layer (PCS) module in accordance with the present invention;

FIG. 4 is a schematic block diagram of a programmable transmit physical coding sub-layer (PCS) module in accordance with the present invention;

FIG. 5 is a graphic example of framing encoded data in accordance with the present invention;

FIG. 6 is a further example of framing data in accordance with the present invention;

FIG. 7 is a continuation of the FIG. 6 example of framing data in accordance with the present invention;

FIG. 8 is a diagram depicting framing decoded data in accordance with the present invention;

FIG. 9 is a logic diagram of a method for framing transmit encoded output data in accordance with the present invention; and

FIG. 10 is a logic diagram of a method for linear feedback shifting in accordance with the present invention.

DETAILED DESCRIPTION OF THE INVENTION

FIG. 1 is a schematic block diagram of a programmable logic device 10 that includes programmable logic fabric 12, a plurality of programmable multi-gigabit transceivers (PMGT) 14-28 and a control module 30. The programmable logic device 10 may be, for instance, a programmable logic array device, a programmable array logic device, an erasable programmable logic device, and/or a field programmable gate array (FPGA). When the programmable logic device 10 is a field programmable gate array (FPGA), the programmable logic fabric 12 may be implemented as a symmetric array configuration, a row-based configuration, a sea-of-gates configuration, and/or a hierarchical programmable logic device configuration. The programmable logic fabric

12 may further include at least one dedicated fixed processor, such as a microprocessor core, to further facilitate the programmable flexibility offered by a programmable logic device 10.

The control module 30 may be contained within the programmable logic fabric 12 or it may be a separate module. In either implementation, the control module 30 generates the control signals to program each of the transmit and receive sections of the programmable multi-gigabit transceivers 14-28. In general, each of the programmable multi-gigabit transceivers 14-28 performs a serial-to-parallel conversion on receive data and performs a parallel-to-serial conversion on transmit data. The parallel data may be 8-bits, 16-bits, 32-bits, 64-bits, et cetera wide. Typically, the serial data will be a 1-bit stream of data that may be a binary level signal, multi-level signal, etc. Further, two or more programmable multi-gigabit transceivers may be bonded together to provide greater transmitting speeds. For example, if multi-gigabit transceivers 14, 16 and 18 are transceiving data at 3.125 gigabits-per-second, the transceivers 14-18 may be bonded together such that the effective serial rate is 3 times 3.125 gigabits-per-second.

Each of the programmable multi-gigabit transceivers 14-28 may be individually programmed to conform to separate standards. In addition, the transmit path and receive path of each multi-gigabit transceiver 14-28 may be separately programmed such that the transmit path of a transceiver is supporting one standard while the receive path of the same transceiver is supporting a different standard. Further, the serial rates of the transmit path and receive path may be programmed from 1 gigabit-per-second to tens of gigabits-per-second. The size of the parallel data in the transmit and receive sections, or paths, is also programmable and may vary from 8-bits, 16-bits, 32-bits, 64-bits, et cetera.

FIG. 2 is a schematic block diagram of one embodiment of a representative one of the programmable multi-gigabit transceivers 14-28. As shown, the programmable multi-gigabit transceiver includes a programmable physical media attachment (PMA) module 32, a programmable physical coding sub-layer (PCS) module 34, a programmable interface 36, a control module 35, a PMA memory mapping register 45 and a PCS register 55. The control module 35, based on the desired mode of operation for the individual programmable multi-gigabit transceiver 14-28, generates a programmed deserialization setting 66, a programmed serialization setting 64, a receive PMA_PCS interface setting 62, a transmit PMA_PCS interface setting 60, and a logic interface setting 58. The control module 35 may be a separate device within each of the multi-gigabit transceivers and/or included within the control module 30. In either embodiment of the PMGT control module 35, the programmable logic device control module 30 determines the corresponding overall desired operating conditions for the programmable logic device 10 and provides the corresponding operating parameters for a given multi-gigabit transceiver to its control module 35, which generates the settings 58-66.

The programmable physical media attachment (PMA) module 32 includes a programmable transmit PMA module 38 and a programmable receive PMA module 40. The programmable transmit PMA module 38 is operably coupled to convert transmit parallel data 48 into transmit serial data 50 in accordance with the programmed serialization setting 64. The programmed serialization setting 64 indicates the desired rate of the transmit serial data 50, the desired rate of the transmit parallel data 48, and the data width of the transmit parallel data 48. The programmable receive PMA

module **40** is operably coupled to convert receive serial data **52** into receive parallel data **54** based on the programmed deserialization setting **66**. The programmed deserialization setting **66** indicates the rate of the receive serial data **52**, the desired rate of the receive parallel data **54**, and the data width of the receive parallel data **54**. The PMA memory mapping register **45** may store the serialization setting **64** and the deserialization setting **66**.

The programmable physical coding sub-layer (PCS) module **34** includes a programmable transmit PCS module **42** and a programmable receive PCS module **44**. The programmable transmit PCS module **42**, which will be described in greater detail with reference to FIG. 4, receives transmit data words **46** from the programmable logic fabric **12** via the programmable interface **36** and converts them into the transmit parallel data **48** in accordance with the transmit PMA_PCS interface setting **60**. The transmit PMA_PCS interface setting **60** indicates the rate of the transmit data words **46**, the size of the transmit data words (e.g., 1-byte, 2-bytes, 3-bytes, 4-bytes, et cetera) and the corresponding transmission rate of the transmit parallel data **48**. The programmable receive PCS module **44**, which will be described in greater detail with reference to FIG. 3, converts the receive parallel data **54** into receive data words **56** in accordance with the receive PMA_PCS interface setting **62**. The receive PMA_PCS interface setting **62** indicates the rate at which the receive parallel data **54** will be received, the width of the parallel data **54**, the transmit rate of the receive data words **56** and the word size of the receive data words **56**.

The control module **35** also generates the logic interface setting **58** that provides the rates at which the transmit data words **46** and receive data words **56** will be transceived with the programmable logic fabric **12**. Note that the transmit data words **46** may be received from the programmable logic fabric **12** at a different rate than the receive data words **56** are provided to the programmable logic fabric **12**.

As one of average skill in the art will appreciate, each of the modules within the PMA module **32** and PCS module **34** may be individually programmed to support a desired data transfer rate. The data transfer rate may be in accordance with a particular standard such that the receive path, i.e., the programmable receive PMA module **40** and the programmable receive PCS module **44** may be programmed in accordance with one standard while the transmit path, i.e., the programmable transmit PCS module **42** and the programmable transmit PMA module **38** may be programmed in accordance with another standard.

FIG. 3 is a schematic block diagram of a programmable receive PCS module **44** that includes a programmable data alignment module **70**, a programmable descramble and decode module **72**, a programmable storage module **74**, and a programmable decode and verify module **76**. The programmable data alignment module **70** includes a synchronous state machine **78**, a value detect realign module **80**, a block synchronization module **82**, and a multiplexer **84**. The programmable descramble and decode module **72** includes a 64b/66b descrambling module **88**, an 8b/10b decoding module **86** and a multiplexer **90**. The programmable storage module **74** includes a channel bonding module **94**, an elastic storage buffer **92** and a multiplexer **96**. The programmable decode and verify module **76** includes a receiver CRC (cyclic redundancy check) module **100**, a 64b/66b decoding module **98**, and a multiplexer **102**.

In operation, the programmable data alignment module **70** receives the receive parallel data **54**. Based on the receive PMA_PCS interface setting **62**, the receive parallel data **54**

may be passed via multiplexer **84** without processing, may be processed by the value detect realign module **80** and then passed via multiplexer **84** and/or further processed via the block synchronization module **82**. As such, the setting **62** may bypass the programmable data align module **70**, perform a value detection realignment and pass the realigned data and/or further utilize block synchronization, which is typically used for 10 gigabits-per-second signaling. The synchronization state machine **78** coordinates the alignment of the receive parallel data **54** via the value detect realign **80** and the block synchronization module **82**. In addition, once the value detect realignment module **80** indicates that the data is valid and the block synchronization module **82** indicates that the PCS module is now in sync with the receive parallel data **54**, the sync state machine **78** generates a lock signal.

The controls of the value detect realign module **80** include receive polarity of the signal, alignment information, et cetera.

The programmable descramble and decode module **72** receives the output of multiplexer **84** and, based on setting **62**, either passes the data via multiplexer **90**, descrambles it via the 64b/66b descrambler **88**, or decodes it via the 8b/10b decode module **86**. The 64b/66b descrambling module **88** will be described in greater detail with reference to FIG. 8. The 8b/10b decoding module **86** may be further described in co-pending U.S. patent application Ser. No. 10/660,191 filed Sep. 11, 2003, by Kryzak and Boecker entitled "Enhanced 8B/10B Encoding/Decoding and Applications Thereof."

The programmable storage module **74** may buffer the data it receives from multiplexer **90** via the elastic store buffer **92** to facilitate channel bonding or pass the data directly to multiplexer **96**. The channel bonding module **94** enables the receiver of one programmable multi-gigabit transceiver to be linked or bonded with one or more other receivers within another multi-gigabit transceiver to increase the effective serial data rate.

The programmable decode and verify module **76** receives the output of multiplexer **96** and passes it directly as the receive data word **56** in accordance with setting **62**, processes the data via a receive CRC module **100** and provides that as the output, or decodes it via the 64b/66b decoding module **98**. The 64b/66b decode module **98** is described in greater detail with reference to FIG. 8.

As one of average skill in the art will appreciate, the programmable receive PCS module **44** is readily programmable via settings **62** (which may control multiplexers **84**, **90**, **96**, and **102**) to decode the receive parallel data **54** using a variety of decoding schemes, to process channel bonding, to verify and lock the incoming data, et cetera, thereby enabling compatibility with various standards.

FIG. 4 is a schematic block diagram of the programmable transmit PCS module **42** that includes a programmable verify module **110**, a programmable encode module **112**, a programmable storage module **114**, and a programmable scramble module **116**. The programmable verify module **110** includes a transmit CRC module **118** and a multiplexer **120**. The programmable encode module **112** includes a 64b/66b encoding module **122**, an 8b/10b encoding module **124**, and a multiplexer **126**. The programmable storage module **114** includes an elastic storage buffer **128** and a multiplexer **130**. The programmable scramble module **116** includes a scramble module **132**, a framing module **134**, and a PMA converter **136**.

The programmable verify module **110** is operably coupled to receive the transmit data words **46** and either pass them

directly to the programmable encoding module **112** or perform a cyclic redundancy check upon them. The transmit PMA_PCS interface setting **60** indicates whether the transmit data words **46** will be directly passed to the programmable encode module **112** or be subject to a cyclic redundancy check. The programmable encoding module **112**, based on setting **60**, either encodes the data received from the programmable verify module **110** via the **8b/10b** encoder **124**, the **64b/66b** encoder **122** or passes the data directly to the programmable storage module **114**. The **64b/66b** encoder **122** is described in greater detail with reference to FIGS. 5-7. The **8b/10b** encoder **224** is more fully described in co-pending patent application Ser. No. 10/659,971, filed Sep. 11, 2003, by Boecker, Black and Groen, entitled "Receiver Termination Network and Application Thereof."

The programmable storage module **114**, based on setting **60**, either passes the data that it receives from the programmable encode module **112** or stores it in the elastic storage buffer **128**. The elastic storage buffer **128** allows for differing time rates between the transmit data words **46** and the transmit parallel data **48**. For example, if the transmit data words **46** are 1-byte words at a rate of 500 megahertz and the transmit parallel data **48** is 2-bytes width at 300 megahertz, the data-per-cycle rate is different between the transmit data words **46** and the transmit parallel data **48**. Accordingly, the elastic storage buffer **128** allows for data to accumulate in the elastic storage buffer and thus accommodate the differing data-per-rate discrepancies between the transmit data words **46** and the transmit parallel data **48**.

The programmable scramble module **116** receives the output of multiplexer **130** and either passes it directly to the PMA converter **136** to produce the transmit parallel data **48** based on control signals or scrambles the data via the scramble module **132** and the framing module **134**. The controls for the PMA converter **136** include polarity of the parallel data **48** and an indication of which path the data will be received from. The scramble module **132** and framing module **134** will be further described with reference to FIGS. 5-7.

As one of average skill in the art will appreciate, the programmable transmit PCS module **42** may be programmed in a variety of ways to directly pass the transmit data words **46**, encode them, scramble them, buffer them, et cetera. As such, with a wide diversity in programming abilities, the programmable transmit PCS module **42**, as well as the entire programmable multi-gigabit transceiver, may be programmed in accordance with many standards.

FIG. 5 is a diagram depicting framing of encoded data in accordance with the present invention. The framing process is implemented via an $Nb/(N+m)b$ encoder **122**, an elastic storage buffer **128**, a scrambling module **132** and a framing (or gearbox) module **134**. For instance, in one embodiment, N may be 64 and m may be 2, and, thus, the $Nb/(N+m)b$ encoder **122** may be a **64b/66b** encoder. In other embodiments, $Nb/(N+m)b$ encoder **122** may be a **64b/(64+m)b** encoder, where m is 3 or more.

In operation, the $Nb/(N+m)b$ encoder **122** receives N -bit input data **144** via a bus that has a bus width of $N/2$. For example, if the N -bit input data **144** corresponds to 64 bit data then the $N/2$ bus will be a 32-bit bus. The encoder **122** encodes the N -bit input data **144** to produce $(m+N/2)$ bits of the input code word during a processing cycle. A processing cycle may include one or more clock cycles. Thus, every 2 processing intervals, the encoder **122** outputs a complete input code word. For **64b/66b** encoding and an input bus of 32 bits, the encoder **122** outputs a 66-bit code word every two processing intervals.

The elastic storage buffer **128** stores the $(m+N/2)$ bits (e.g., 34 bits for **64b/66b** encoding) of the input code word. As shown, the elastic storage contents **142** includes a plurality of lines of memory, where each line of the elastic storage buffer **128** includes 2 sections; each storing $m+N/2$ bits of information. For **64b/66b** encoding, the elastic storage contents **142** include the 66-bit encoded code word. In this instance, the m -bits in the first section of a line (i.e., the left section) correspond to the sync-header and the $N/2$ bits store the first 32-bits of a 66-bit code word. The m -bits of the second section of a line contains null (or don't care) information and the $N/2$ bits of the second section store the second 32-bits of the 66-bit code word.

As is also shown, each line of the elastic storage contents **142** has a corresponding shift offset **140**. The shift offset (k) is an integer value in the range of 1 to $N/2m$. For example, for a 66-bit encoded code word, N is 64 and m is 2 such that the shift offset range is 1 to 16. The shift offset is used by the framing module **134** to determine how much of the incoming code word it will process to produce its corresponding output. This will be described in greater detail with reference to FIGS. 6 and 7.

The scramble module **132** receives $N/2$ bits of the input code word and scrambles them to produce an $N/2$ bits scrambled code word. The scrambling module **132** may be a linear feedback shift register that executes a generator polynomial to produce the scrambled code word. For **64b/66b** encoding the polynomial may correspond to $G(X)=1+X^{39}+X^{58}$.

The framing module **134** receives $m+N/2$ bits of the input code word per processing interval and outputs $N/2$ bits of information. For example, if the process is for **64b/66b** encoding the framing module receives 34 bits of information and outputs 32 bits of encoded information. The framing module **134** also receives the $N/2$ bit scrambled code word from the scramble module **132**. Based on the internal scrambling performed by the framing module **134**, the shift offset (k), and the $N/2$ bits scrambled code word received from scramble module **132**, the framing module **134** produces a portion of the $N+m$ bit transmit code word **146**.

FIG. 6 illustrates an example of framing data as may be performed by the circuit of FIG. 5 and/or the circuit of FIG. 8. In this example, the resulting code word is 18-bits, 16 bits of which correspond to encoded data, 1 bit for a sync-header and 1 bit of don't-care data. Accordingly, for this example, the elastic storage content **142** includes a plurality of 18 bit lines for codes words having $N=16$, and $m=1$. With $N=16$ and $m=1$, the shift offset is in the range of 1 to 8 (i.e., 1 to $N/2m$, which is 1 to $16/(2*1)=1$ to 8). As shown, the 1st line of the elastic storage (i.e., the bottom line) includes the 1-bit sync-header (m) followed by 8-bits of encoded data, which is designated as 1a. The 2nd section of this line of the elastic store stores a don't-care bit (x) followed by 8-bits of encoded data, which is designated as 1b.

The scramble module **132** in this example sequentially receives the 8-bits of the encoded data stored in the first and second sections of elastic storage and outputs an 8-bit scrambled value. As shown, the 1st 8-bits that the scramble module **132** receives corresponds to the 1a portion of the 1st code word stored in the elastic storage. Scramble module **132** scrambles these 8-bits to produce 8-bits of a scrambled code word, which is designated as SC-1a. The square bracketed values following the designation of SC-1a correspond to bit numbers of the 8-bits of the scrambled code word. The scramble module **132** continues to scramble 8-bits of the received data per scrambling interval, which may include one or more clock cycles. The resulting

scrambled contents provide 16-bit scrambled code words, where a first portion of the 16-bit scrambled code word is one line and the second portion of the 16-bit scrambled code word is on the next line.

The framing module **134** receives, per scrambling interval, 9-bits of information from the elastic storage buffer and the 8-bits scrambled output from the scramble module **132**. The framing module **134** functions to preserve the 1-bit sync-header (m) and scrambles at least a portion of the remaining 8-bits of encoded data it receives from the elastic storage buffer. During the 1st scrambling interval, the framing module **134** outputs 8-bits of data as shown in the bottom line of the 17-bit transmit code words, which are transmitted 1-byte-per-cycle. As such, the framing module **134**, based on the scrambled inputs from the scramble module **132** and the 9-bits from the elastic storage, outputs the 1-bit sync-header followed by 7-bits of a scrambled code word produced by the framing module **134** corresponding to scrambling of the 1a inputted code word section. As such, the designation FM-1a [0,6] corresponds to 7 scrambled bits of the input 1a produced by framing module **134**. Accordingly, the 1st portion of the 1st code word 1a is not completely represented in the 1st line outputted by the framing module **134**. The framing module **134** outputs the remaining 7th scrambled bit produced by the scrambling module **132**, which is designated SC-1a [7], during the next scrambling interval. The remaining portion of the 2nd interval output of framing module **134** corresponds to the scrambling performed by the framing module on 7-bits of the 2nd portion (1b) of the 1st code word.

As shown, during the 2nd output interval of framing module **134** only 7-bits are outputted that correspond to the 2nd portion (1b) of the 1st code word. Thus, on the 3rd output interval of framing module **134**, it first outputs the remaining bit of the 2nd portion of the 1st code word that was produced by scrambling module **132**, which is designated SC-1b[7]. The framing module then outputs the sync-header for the 2nd code word stored in the elastic storage. In the same interval, the framing module **134** outputs 6 scrambled bits of the 1st portion of the 2nd code word it produces, which is designated as FM-2a[0,5].

At this point, only 6 of the 8 bits have been outputted for the scrambling of the 1st portion of the 2nd code word. Thus, on the 4th output interval, the framing module **134** begins by outputting bits 6 and 7 of the 1st portion of the 2nd code word produced by the scramble module **132**, which is designated SC-2a[6,7]. The remaining output during the 4th interval corresponds to the scrambling of 6-bits produced of the 2nd portion of the 2nd code word produced by framing module **134**, which is designated FM-2b[0,5].

During the 5th output interval, the framing module **134** first outputs the remaining 2 bits of the scrambling of the 2nd portion of the 2nd code word produced by scrambling module **132**, which is designated SC-2b[6,7]. The framing module **134** then outputs the 1-bit sync-header for the 3rd code word m followed by 5-bits of scrambled code word of the 1st portion of the 3rd code word produced by framing module **134**, which is designated FM-3a[0,4].

During the 6th output interval, the framing module **134** first outputs the remaining 3-bits of the scrambling of the 1st portion of the 3rd code word as produced by scrambling module **132**, which is designated SC-3a[5,7]. The framing module **134** also outputs 5-bits of the scrambling it produces regarding the scrambling of the 2nd portion of the 3rd code word, which is designated FM-3b[4,0].

As can be seen over the next intervals 7-15, the framing module **134** outputs one less bit of the scrambled code word

it produces every two intervals and one more bit from the scrambled module every two intervals. At output cycle 16 of framing module **134**, the offset shifting of the output of the framing module has looped completely around such that the framing module **134** during output cycle 16 outputs the scrambled code word produced by scrambling module **132**, which is designated SC-8a[0,7]. Similarly, for output cycle 17, the framing module **134** outputs the scrambled code word portion produced by scrambling module **132**, which is designated SC-8b[0,7].

To maintain alignment of the outputting of the scramble module **132** with the outputting of framing module **134**, the scrambling module **132** slips, or skips an output interval every 16 intervals to maintain alignment with the outputting of framing module **134**. The slipping results because the framing module **134** needs to output 17 bits of code word per two intervals while the scramble module only outputs 16 bits of code words per two intervals. Thus, every 16 intervals of outputting a 17-bit code word, requires the outputting by the scrambling module **132** to slip one cycle.

By slipping, or skipping, an interval, as shown at output interval 17, the process of outputting the 17-bit code words by the framing module is repeated at output interval 18, which has the same output bit pattern as output interval 1.

As one of average skill in the art will appreciate, the example of FIG. 6 may be extended to a N-bit/N+m bit encoding system where the shift offset is in a value ranging from 1 to N/2m. In an embodiment, N may be equal to 64. As one of average skill in the art will also appreciate, during the 1st two intervals, which corresponds to the shift offset having a value of 1, the framing module **134** outputs bits 0 through N/2-(m*k)-1 bits of the N-bit shifted code word. Thus, for intervals 1 and 2, where the shift offset k is 1, the framing module **134** outputs bits 0-6 of the 1st code word where N is 16, m is 1 and k is 1. Continuing with the example, during the 3rd and 4th output cycles, where the shift offset is 2, the framing module outputs 6 bits of information (e.g., bits 0-5).

FIG. 7 continues the example of framing data and as shown in FIG. 6 and further illustrates details of scrambling module **132** and framing module **134**. The framing module **134** includes logic circuitry **154** and framing module scrambler **150**. The framing module scrambler **150** is a linear feedback shift register (LFSR) and has a corresponding LFSR function **152**. For example, the LFSR function may be implemented as a generating polynomial, which for 64b/66b is $G(x)=1+X^{39}+X^{58}$. The scrambling module **132** includes an identical LFSR structure to that of the framing module scrambler.

The scrambling module **132** receives data inputs from the elastic storage device. In this example, it receives 8 bits of a code word per LFSR cycle. As shown, the LFSR cycles are listed as 1-18. During the first LFSR cycle, the scramble module **132** receives 8 bits of a first portion of a first code word. During the second LFSR cycle, the scramble module **132** receives 8 bits of the second portion of the first code word. Accordingly, the scramble module **132** receives the first portion of a code word during odd numbered LFSR cycles and receives the second portion of the code word during the even numbered LFSR cycles. Each portion of a code word in this example includes 8-bits, which are designated [0c-7c]. The lower case C indicates that the data being received is current for this particular LFSR cycle.

For each LFSR cycle, the scrambling module **132** executes the LFSR function **152** on the current 8 bits of a code word to produce a scrambled code word as illustrated in FIG. 6. Thus, during the 1st LFSR cycle the scrambling

11

module **132** outputs the scrambled code word, which in FIG. **6**, has the designation of SC-1a[0,7].

The logic circuitry **154** is operably coupled to receive the current scrambled code word produced by the scramble module **132** and to provide an 8-bit input to the framing module scramble **150**. The logic circuitry **154** is also operably coupled to provide the output of the framing module **134**. The logic circuitry **154** is also operably coupled to receive the sync-header **156** from the elastic storage device and to provide it at the appropriate time and in the appropriate location of the transmit code word **146**.

As previously discussed in FIG. **6**, the framing module **134** uses at least a portion of the scrambled resultant produced by scramble module **132** to produce the resultant transmit code word **146**. To maintain alignment of the scrambling of data, the logic circuit **154** utilizes the previous input from the elastic store and/or a previous output of the scrambling module in a corresponding bit position as part of the input to the frame module scrambler **150**. For instance, during the 1st LFSR cycle, the logic **154** selects the 7th bit from a previous code word inputted to, or outputted from, the scramble module **132** in bit position 7 of the frame module scrambler input, which is designated as 7p. The remaining bits of frame module scrambler input are the 7 current bits of the data input from the elastic store, which are designated 0c-6c. As such, the frame module scrambler **150** is scrambling 8-bits, 1 from a previous input or output of scramble module **132** and the remaining 7 bits from the current input from the elastic storage device. The same bit pattern is repeated for cycle 2.

During the 1st LFSR cycle, the logic **154** outputs part of the 1st portion of the transmit code word **146** and the sync-header (SH). As shown, the output includes the sync header followed by 7 bits of scrambled data produced by the frame module scrambler **150**, which are designated fms6-fms0. During the 2nd LFSR cycle, the logic **154** utilizes a previous bit outputted by the scramble module **132**, which is designated as sm7, and 7 bits outputted by the frame module scrambler **150** to produce the next scrambled output. At this point, the code word **146** is 1-bit short of being complete. This bit is outputted during the 3rd LFSR cycle.

During the 3rd LFSR cycle, while the scramble module receives all 8-bits of the current input, the frame module scrambler only receives 6 of the current 8 bits, 5c-0c and receives bits 6 and 7 from the previous input or output of scramble module **132**. The same input pattern occurs with respect to the 4th LFSR cycle. Also, the 3rd LFSR cycle, the logic **154** outputs the sync header for the 2nd code word, and 6 bits of scrambled data produced by the frame module scrambler **150**. Note that the 6 bits of the scrambled data produced by the frame module scrambler correspond to the 6 bits of the current input being received by the frame module scrambler **150**.

Accordingly, the input bits having a "p" designation to the frame module scrambler act as place holders such that the frame module scrambler is effectively adjusted to scramble only the bits of the current input code word portion. The scrambling by the frame module scrambler continues as shown for LFSR cycles 4-14.

At the 15th LFSR cycle, the 1st portion of an 8th code word is inputted to the scramble module **132** and a portion of that input is provided to the framing module **150**. As shown during the 15th cycle, the frame module scrambler input has 7 of the 8 bits coming from the previous input and/or output of scramble module **132** and only 1 bit, bit position 0, coming from the current data input from the elastic storage device. The resulting output for cycle 15 has 7 bits corre-

12

sponding to the previously scrambled output of scramble module **132** and 1-bit of sync-header. On the 16th and 17th cycles, the frame module scrambler receives no input and the entire output for cycles 16 and 17 are produced by scramble module **132**. As also shown, the 17th cycle input to the scramble module **132** is skipped to realign the inputting of data into the scrambling module and the frame module scrambler.

FIG. **8** is a logic diagram of framing decoded data. The framing apparatus includes the descramble module **88** that includes a scrambling module **132** and framing module **134**, elastic storage buffer **92** and an Nb/(N+m)b decoder **98**. In general, the descramble module **88** receives a receive code word **160** that includes a sync-header, a 1st portion and a 2nd portion. The descramble module **88** descrambles the data, which is provided to the elastic storage buffer **92**. The elastic storage buffer **92** provides, during each processing interval, the Nb/(N+m)b decoder with m+N/2 bits of data. The decoder performs an inverse function of the encoder (as was described in connection with FIGS. 5-7).

As indicated, the scramble function and descramble function are identical to the framing of encoded data. In essence, the scramble function is multiplying one code word with a subsequent code word to produce the next code word. As is generally known in the coding art, code words are unique values and have the properties that one code word multiplied, using finite field arithmetic, with another code word yields a third code word or the same code word. For example, 0 is one valid code word, thus any code word multiplied with 0 results in that same code word. Further, code word 1 multiplied with code word 2 equals code word 3. Similarly, code word 3 multiplied with code word 2 equals code word 1. Based on this principle, the scrambling process is one ordered finite field multiplication of code words, for example code word 1 multiplied with code word 2 to produce code word 3, and the descrambling process is a reverse ordered finite field multiplication of codes words, for example, code word 3 multiplied with code word 2 equals code word 1. Thus, by performing the finite field mathematics in reverse order of the scrambling function, the descrambling function is obtained. Accordingly, the same concepts for the scrambling or framing of data as indicated in FIGS. 5 and 6 apply to the descrambling and/or deframing of data by the descramble module **88** of FIG. **8**.

The programmable receive PCS module **44** of FIG. **3** and/or the programmable transmit PCS module **42** of FIG. **4** may perform the method for framing data as shown in FIG. **9**. The process begins at Step 170 where a scrambling remainder between scrambling of an input code word in accordance with a 1st scrambling protocol and scrambling of the input code word in accordance with an adjustable scrambling protocol is determined. The scrambling remainder corresponds to the number of bits being used from the scramble module to complete the scrambling of a code word. With reference to FIG. **6**, the scrambling remainder for cycles 2 and 3 is 1, the scrambling remainder for cycles 4 and 5 is 2, et cetera.

Further, the scrambling remainder may be determined based on a current modulo count for the scrambling of the input code word in accordance with the 1st scrambling protocol and is based on the bit size difference between the transmit encoded output and the 1st scrambled code word. This was illustrated and discussed with reference to FIGS. 6 and 7. The 1st scrambling protocol and the adjustable scrambling protocol may be implemented as a linear feedback shift register that implements one or more generator polynomials. In one embodiment, the adjustable scrambling

13

protocol is based on the generator polynomial of the 1st scrambling protocol where a number of stages in the linear feedback shift register are determined based on the scrambling remainder.

The process then proceeds to Step 172 where the adjustable scrambling protocol is adjusted based on the scrambling remainder to produce an adjusted scrambling protocol. This was illustrated in FIG. 7 where the input to the frame module scrambler is adjusted. The process then proceeds to Step 174 where the input code word is scrambled in accordance with the 1st scramble protocol to produce a 1st scrambled code word. with reference to FIGS. 6 and 7, the 1st scrambling protocol corresponds to the scrambling of the input code word by the scrambling module 132.

The process then proceeds to Step 176 where the input code word is scrambled in accordance with the adjusted protocol to produce a scrambled partial code word. This corresponds to the scrambling performed by the frame module scrambler 150 of FIGS. 6 and/or 7. Note that at cycle 15, 16 and 17, the pattern begins to rollover with respect to the scrambling. As such, when a rollover condition exists, as at cycle 16 and/or 17 the scrambling by the frame module scrambler 150 is not utilized and the resulting outputted scrambled word is produced by scramble module 132. Once the rollover is complete, the pattern repeats as in accordance with cycle 1. As an alternate approach to adjusting the scrambled protocol, the frame module scrambler 150 may have shift stages (i.e., S0-S7 in FIG. 7) removed based on the scrambling remainder such that the LFSR function 152 is adjusted.

The process then proceeds to Step 178 where a portion of the 1st scrambled word is determined based on the scrambling remainder. The portion corresponds to the particular LFSR cycle, as shown in FIG. 7, being implemented. During cycles 2 and 3 the scrambling remainder is 1, during cycles 4 and 5 the scrambling remainder is 2, et cetera. As such, based on this scrambling remainder, the portion of the scrambled resultant produced by scrambling module 132 is used. The process then proceeds to Step 180 where the scrambled partial code word is combined with the portion of the 1st scrambled code word to produce the transmit code word. This is illustrated in FIGS. 6 and 7 as the output of the framing module 134.

FIG. 10 illustrates a logic diagram of linear feedback shifting that may be performed by the programmable receive PCS module 44 of FIG. 3 and/or the programmable transmit PCS module 42 of FIG. 4. The process begins at step 190 where an N+m input code word is received. N-bits of the input code word correspond to data and the m bits correspond to header information. For example, N may be 64 and m may be 2 for 64b/66b encoding. Note that the encoding may be extended to 64b/(64+X)b encoding where X is a value greater than 3.

The process then proceeds to step 192 where a first linear feedback shift operation is performed on N bits of the N+m input code word to produce an N bit shifted code word. The process then proceeds to step 194 where the N+m input code word is processed in accordance with a second linear feedback operation to maintain the m bits of the input code word and to produce an N-(m*k) bit shifted code word, wherein k corresponds to shift offset. The process then proceeds to Step 196 where an N-bit shifted output code word is based on the N-m*k bit shifted code word and bits [0,N/2-(m*k)-1] of the N-bit shifted code word. This again was illustrated with reference to the examples of FIGS. 6 and 7.

14

The preceding discussion has presented a method and apparatus for framing transmit encoded data and linear feedback shifting. By utilizing the 1st scrambling protocol as may be implemented via the scramble module 132 and an adjustable scrambling protocol as implemented by the frame module 134, scrambling and descrambling of code words is achieved without the need for a barrel shifter, which reduces die area and power consumption. As one of average skill in the art will appreciate, other embodiments may be derived from the teaching of the present invention without deviating from the scope of the claims.

What is claimed is:

1. A method for framing a transmit code word, the method comprising:

- 15 determining a scrambling remainder between scrambling of an input code word in accordance with a first scrambling protocol and scrambling of the input code word in accordance with an adjustable scrambling protocol;
- 20 adjusting the adjustable scrambling protocol based on the scrambling remainder to produce an adjusted scrambling protocol;
- scrambling the input code word in accordance with the first scrambling protocol to produce a first scrambled code word;
- 25 scrambling the input code word in accordance with the adjusted scrambling protocol to produce a scrambled partial code word;
- determining a portion of the first scrambled code word based on the scrambling remainder;
- 30 combining the scrambled partial code word with the portion of the first scrambled code word to produce the transmit code word; and
- outputting the transmit code word.
- 35 2. The method of claim 1, wherein the determining the scrambling remainder further comprises:
 - determining a current modulo count for the scrambling of the input code word in accordance with the first scrambling protocol during the first timing interval, wherein the modulo count is based on a bit size difference between the transmit code word and the first scrambled code word.
 - 40 3. The method of claim 1, wherein the first scrambling protocol comprises a generator polynomial for an M-bit input code word.
 - 45 4. The method of claim 3, wherein the adjustable scrambling protocol further comprises finite field multiplication of the generator polynomial with the M-bit input code word via a programmable linear feedback shift register, wherein a number of stages of the linear feedback shift register are determined in accordance with the scrambling remainder.
 - 50 5. The method of claim 1 further comprising:
 - encoding a 64-bit digital value utilizing a 64b/66b encoding protocol to produce an encoded code word, wherein the encoded code word includes the input code word and a second input code word, wherein the input code word includes an 2-bit sync header and the second input code word includes 2-bits of null information.
 - 55 6. The method of claim 5 further comprising:
 - 60 scrambling the second input code word in accordance with the first scrambling protocol to produce a second scrambled code word;
 - scrambling the second input code word in accordance with the adjusted scrambling protocol to produce a second scrambled partial code word;
 - 65 determining a portion of the second scrambled code word based on the scrambling remainder; and

15

combining the second scrambled partial code word with the portion of the second scrambled code word to produce a second transmit code word.

7. The method of claim 6, wherein the first scrambling protocol further comprises:

performing a function of $G(x)=1+X^{39}+X^{58}$ on the input code word and the second input code word.

8. The method of claim 6 further comprising:

determining rollover of the scrambling of the second input code word in accordance with the first scrambling protocol, and of the scrambling of the second input code word in accordance with the adjusting scrambling protocol, prior to the scrambling of the second input code word in accordance with the adjusted scrambling protocol; and

when the rollover exists:

scrambling the second input code word in accordance with the first scrambling protocol to produce the second scrambled code word; and

utilizing the second scrambled partial code word as the second transmit code word.

9. The method of claim 1 further comprises:

encoding a 64-bit digital value utilizing a 64b/(64+m)b encoding protocol to produce an encoded code word, wherein the encoded code word includes the input code word and a second input code word, wherein the input code word includes an m-bit sync header and the second input code word includes m-bits of null information, where m is greater than or equal to three.

10. The method of claim 1, wherein the adjusting the adjustable scrambling protocol further comprises:

reducing stages of a linear feedback shift register based on the scrambling remainder to produce the adjusted scrambling protocol.

11. The method of claim 1, wherein the adjusting the adjustable scrambling protocol further comprises:

shifting the input code word to produce a shifted input code word based on the scrambling remainder; and

loading an adjustable linear feedback shift register with the shifted input code word from a linear feedback shift register performing the first scrambling protocol.

12. An apparatus for framing a transmit code word, the apparatus comprising:

an encoding module for generating input code word from input data; and

a scrambling module operably coupled to:

determine a scrambling remainder between scrambling of an input code word in accordance with a first scrambling protocol and scrambling of the input code word in accordance with an adjustable scrambling protocol;

adjust the adjustable scrambling protocol based on the scrambling remainder to produce an adjusted scrambling protocol;

scramble the input code word in accordance with the first scrambling protocol to produce a first scrambled code word;

scramble the input code word in accordance with the adjusted scrambling protocol to produce a scrambled partial code word;

determine a portion of the first scrambled code word based on the scrambling remainder;

combine the scrambled partial code word with the portion of the first scrambled code word to produce the transmit code word; and

output the transmit code word.

16

13. The apparatus of claim 12, wherein the scrambling module further functions to determine the scrambling remainder by:

determining a current modulo count for the scrambling of the input code word in accordance with the first scrambling protocol during the first timing interval, wherein the modulo count is based on a bit size difference between the transmit code word and the first scrambled code word.

14. The apparatus of claim 12, wherein the first scrambling protocol further comprises a generator polynomial for an M-bit input code word.

15. The apparatus of claim 14, wherein the adjustable scrambling protocol further comprises finite field multiplication of the generator polynomial with the M-bit input code word via a programmable linear feedback shift register, wherein a number of stages of the linear feedback shift register are determined in accordance with the scrambling remainder.

16. The apparatus of claim 12, wherein the encoding module further functions to:

encode, as the input data, a 64-bit digital value utilizing a 64b/66b encoding protocol to produce an encoded code word, wherein the encoded code word includes the input code word and a second input code word, wherein the input code word includes an 2-bit sync header and the second input code word includes 2-bits of null information.

17. The apparatus of claim 16, wherein the scrambling module further functions to:

scramble the second input code word in accordance with the first scrambling protocol to produce a second scrambled code word;

scramble the second input code word in accordance with the adjusted scrambling protocol to produce a second scrambled partial code word;

determine a portion of the second scrambled code word based on the scrambling remainder; and

combining the second scrambled partial code word with the portion of the second scrambled code word to produce a second transmit code word.

18. The apparatus of claim 17, wherein the scrambling module further functions, in accordance with the first scrambling protocol, to:

perform a function of $G(x)=1+X^{39}+X^{58}$ on the input code word and the second input code word.

19. The apparatus of claim 17, wherein the scrambling module further functions to:

determine roll-over of the scrambling of the second input code word in accordance with the first scrambling protocol and of the scrambling of the second input code word in accordance with the adjusting scrambling protocol prior to the scrambling of the second input code word in accordance with the adjusted scrambling protocol;

when the roll-over exists:

scramble the second input code word in accordance with the first scrambling protocol to produce a second scrambled code word; and

utilize the second scrambled partial code word as the second transmit code word.

20. The apparatus of claim 12, wherein the encoding module further functions to:

encode a 64-bit digital value utilizing a 64b/(64+m)b encoding protocol to produce an encoded code word, wherein the encoded code word includes the input code word and a second input code word, wherein the input

17

code word includes an m-bit sync header and the second input code word includes m-bits of null information, where k is greater than or equal to three.

21. The apparatus of claim **12**, wherein the scrambling module further functions to adjust the adjustable scrambling protocol by:

reducing stages of a linear feedback shift register based on the scrambling remainder to produce the adjusted scrambling protocol.

18

22. The apparatus of claim **12**, wherein the scrambling module further functions to adjust the adjustable scrambling protocol by:

shifting the input code word to produce a shifted input code word based on the scrambling remainder; and loading an adjustable linear feedback shift register with the shifted input code word from a linear feedback shift register performing the first scrambling protocol.

* * * * *