



US007347907B1

(12) **United States Patent**
Mayle et al.

(10) **Patent No.:** **US 7,347,907 B1**
(45) **Date of Patent:** **Mar. 25, 2008**

(54) **ADJUSTABLE ROOF FITMENT AND METHOD OF MAKING THE SAME**

(76) Inventors: **Steven R. Mayle**, 2274 Augusta Dr., Fremont, OH (US) 43420; **Robert L. Mayle**, 2047 Hyde Rd., Port Clinton, OH (US) 43452

(*) Notice: Subject to any disclaimer, the term of this patent is extended or adjusted under 35 U.S.C. 154(b) by 0 days.

(21) Appl. No.: **11/307,091**

(22) Filed: **Jan. 23, 2006**

Related U.S. Application Data

(60) Division of application No. 10/876,827, filed on Jun. 24, 2004, now abandoned, which is a continuation of application No. 10/125,768, filed on Apr. 18, 2002, now Pat. No. 6,754,993.

(51) **Int. Cl.**
B32B 37/00 (2006.01)

(52) **U.S. Cl.** **156/71; 156/82; 156/272.2**

(58) **Field of Classification Search** 156/82, 156/272.2, 272.4, 379.6, 379.9, 497, 499, 156/71

See application file for complete search history.

(56) **References Cited**

U.S. PATENT DOCUMENTS

4,652,321 A 3/1987 Greko
4,799,986 A 1/1989 Janni
4,872,296 A 10/1989 Janni

4,909,135 A 3/1990 Greko
4,947,614 A 8/1990 Mayle
5,014,486 A 5/1991 Mayle
5,605,019 A 2/1997 Maziekien et al.
5,706,610 A 1/1998 Mayle
5,775,052 A 7/1998 Mayle
5,850,719 A 12/1998 Mayle
5,930,969 A 8/1999 Mayle et al.
5,983,592 A 11/1999 Mayle
6,021,616 A 2/2000 Mayle
6,110,311 A 8/2000 Mayle et al.
6,199,326 B1 3/2001 Mayle
6,374,549 B1 4/2002 Mayle
6,754,993 B1 6/2004 Mayle

Primary Examiner—James Sells
(74) *Attorney, Agent, or Firm*—Standley Law Group LLP

(57) **ABSTRACT**

An adjustable corner fitment for a roof and a method and apparatus for making the same are provided. The adjustable corner fitment may be comprised of a top membrane portion and a base membrane portion. The top membrane portion may have a cutout that may extend from a side of the top membrane portion. The base membrane portion may have four-sides. The first side of the base membrane portion is preferably connected to the second side of the base membrane portion at a first angle greater than 90 degrees, and the third side of the base membrane portion is preferably connected to the fourth side of the base membrane portion at a second angle greater than 90 degrees. It is preferred that the top membrane portion and the base membrane portion are made from thermoplastic olefin (TPO) material or polyvinyl chloride (PVC) material.

19 Claims, 10 Drawing Sheets

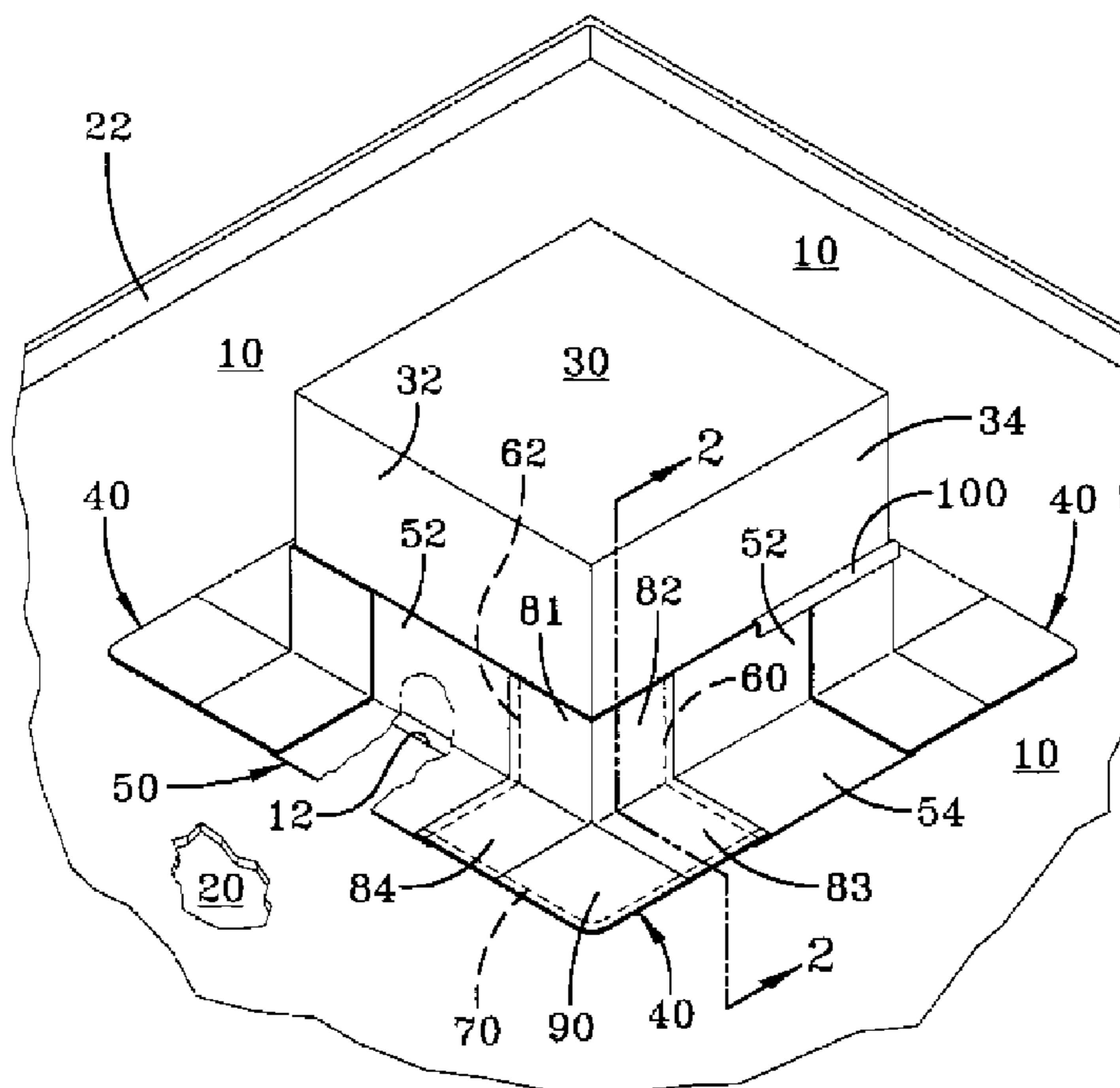

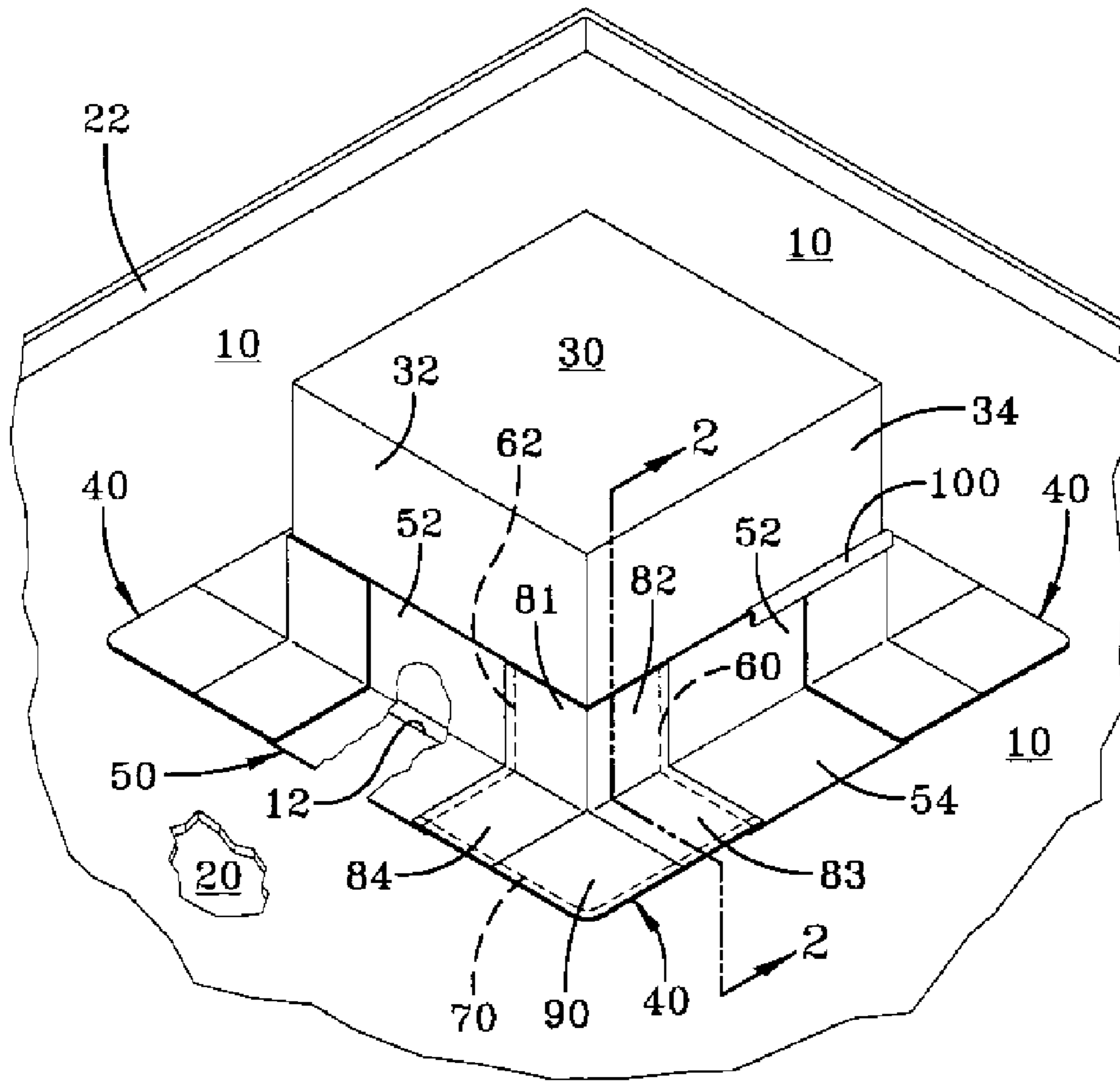

FIG-1

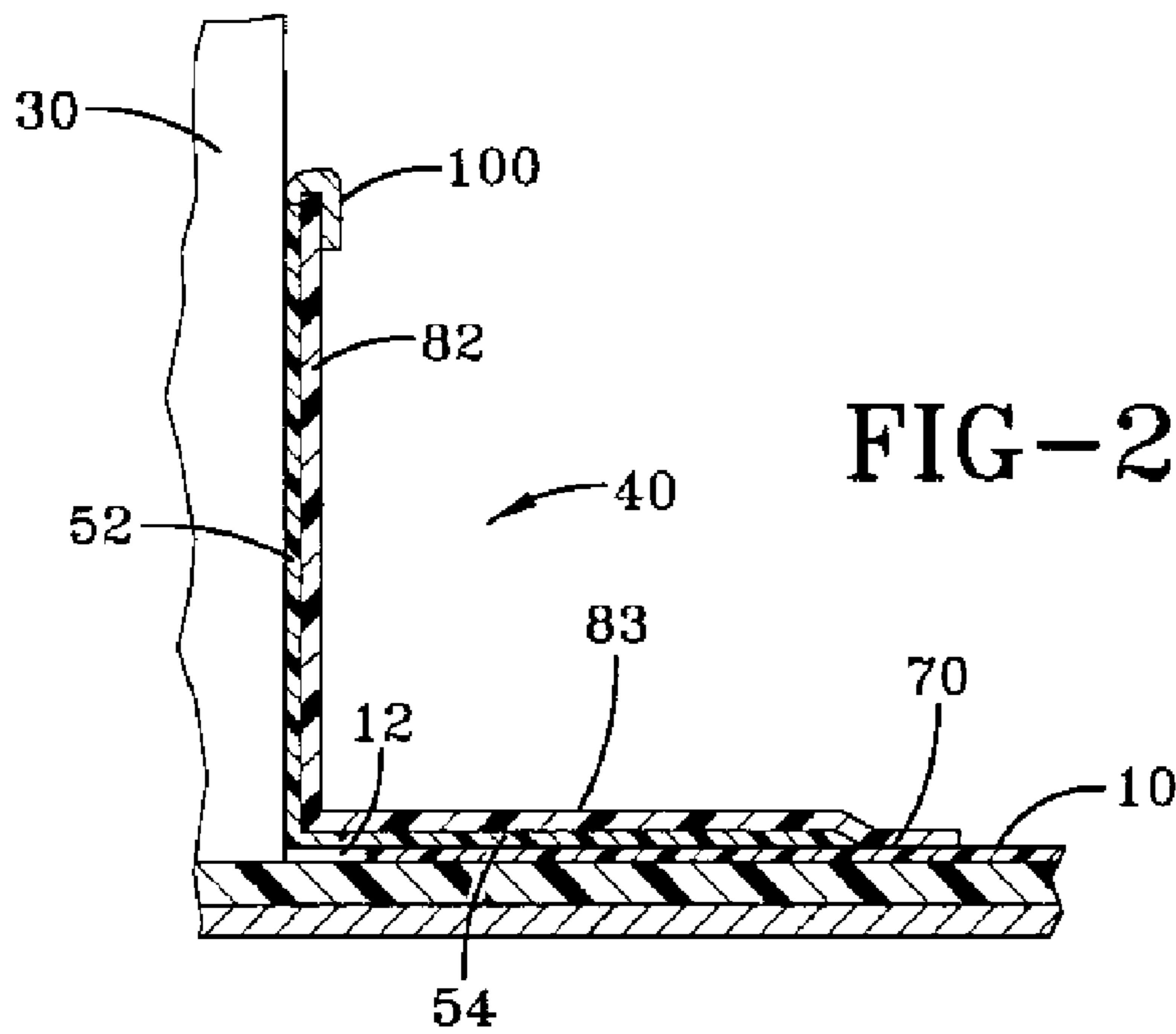

FIG-2

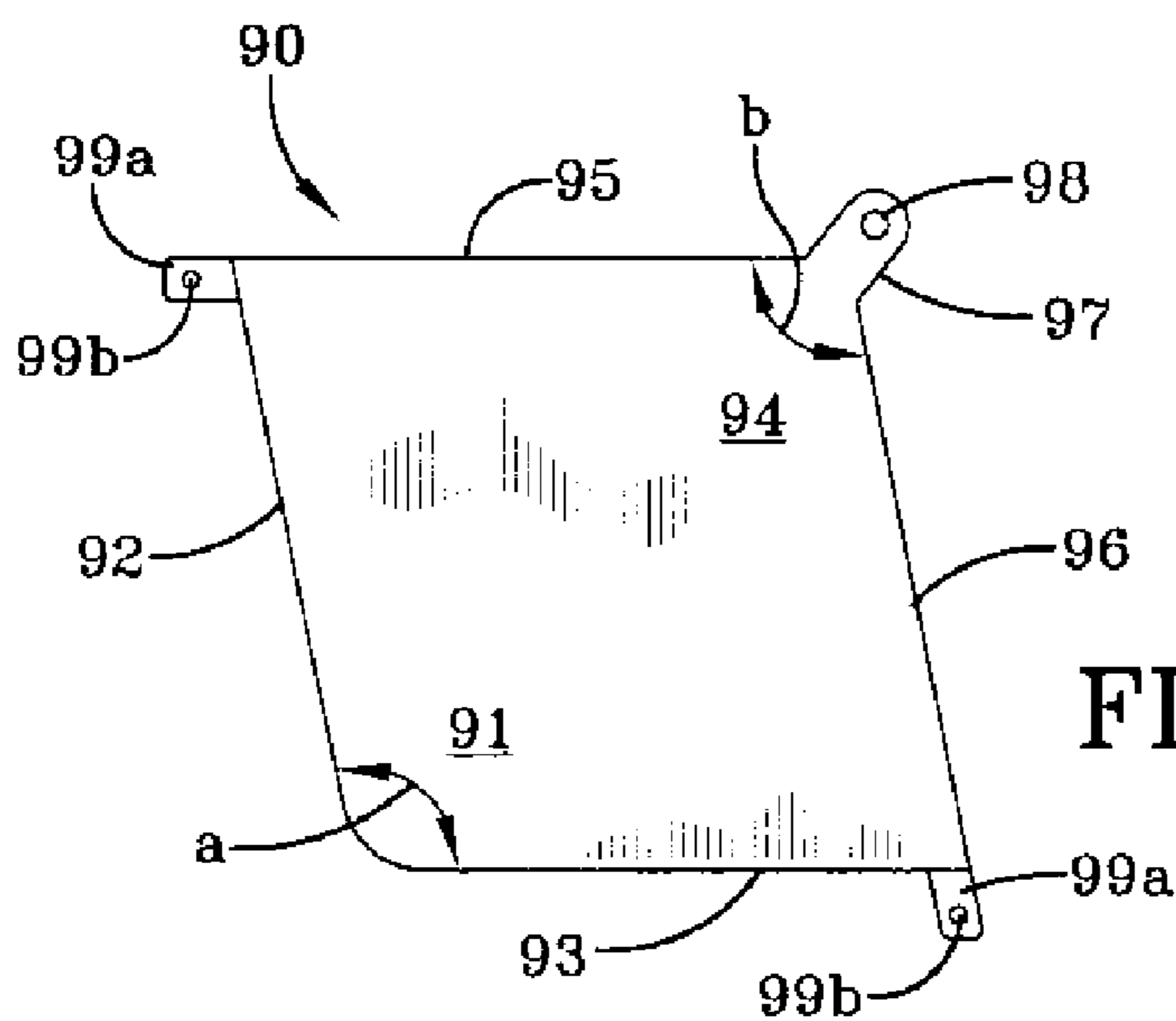

FIG-3A

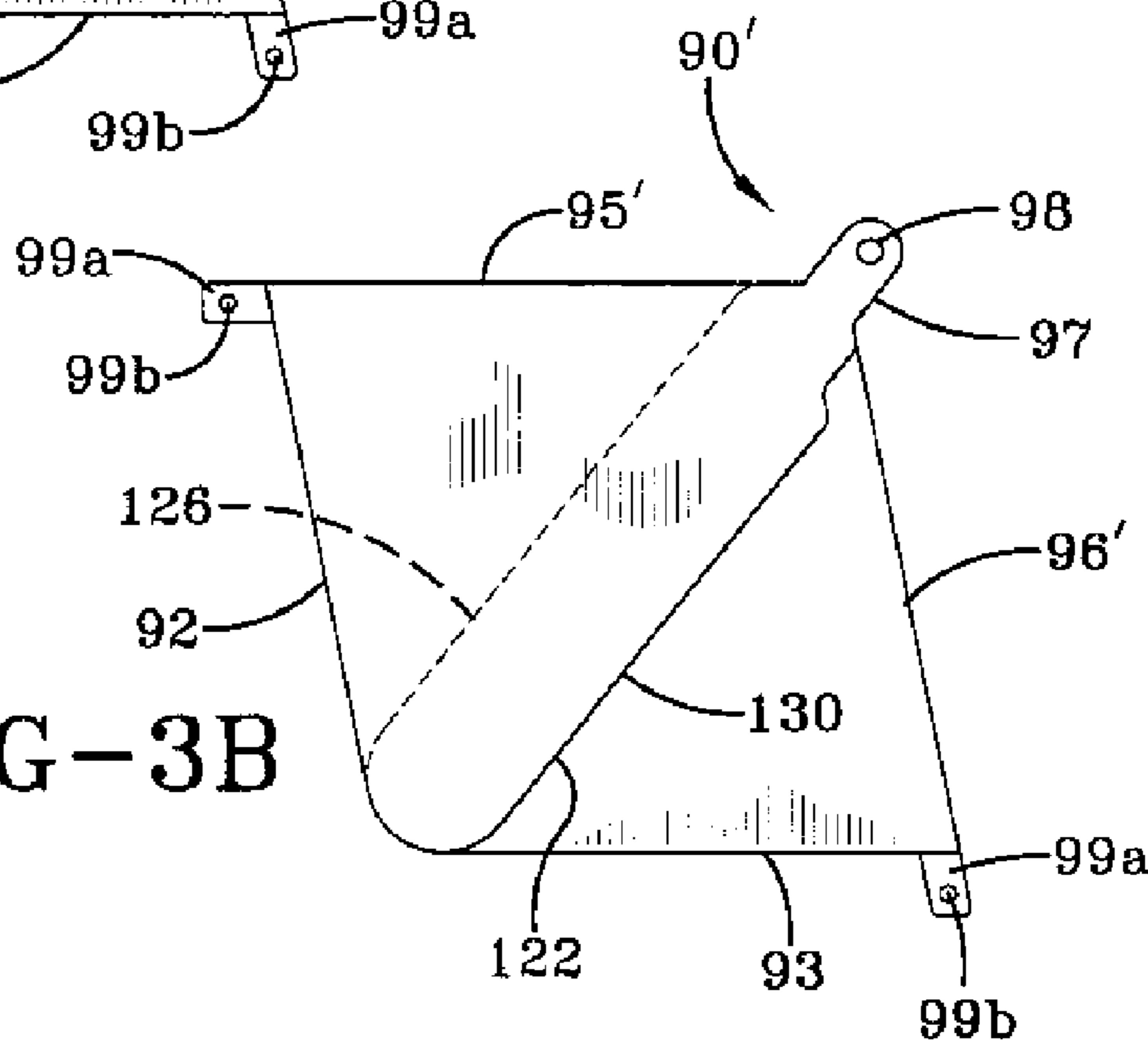

FIG-3B

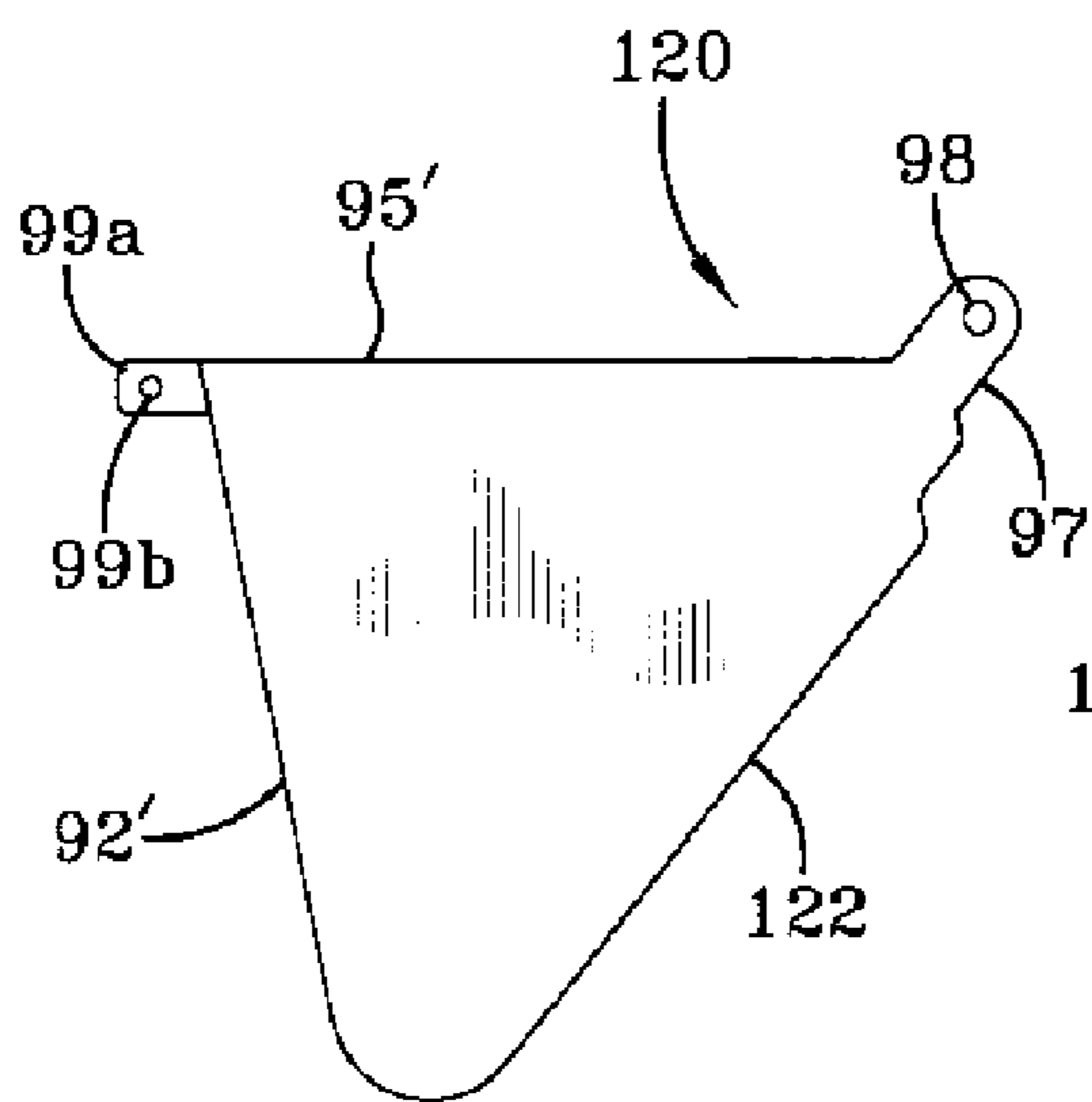

FIG-3C

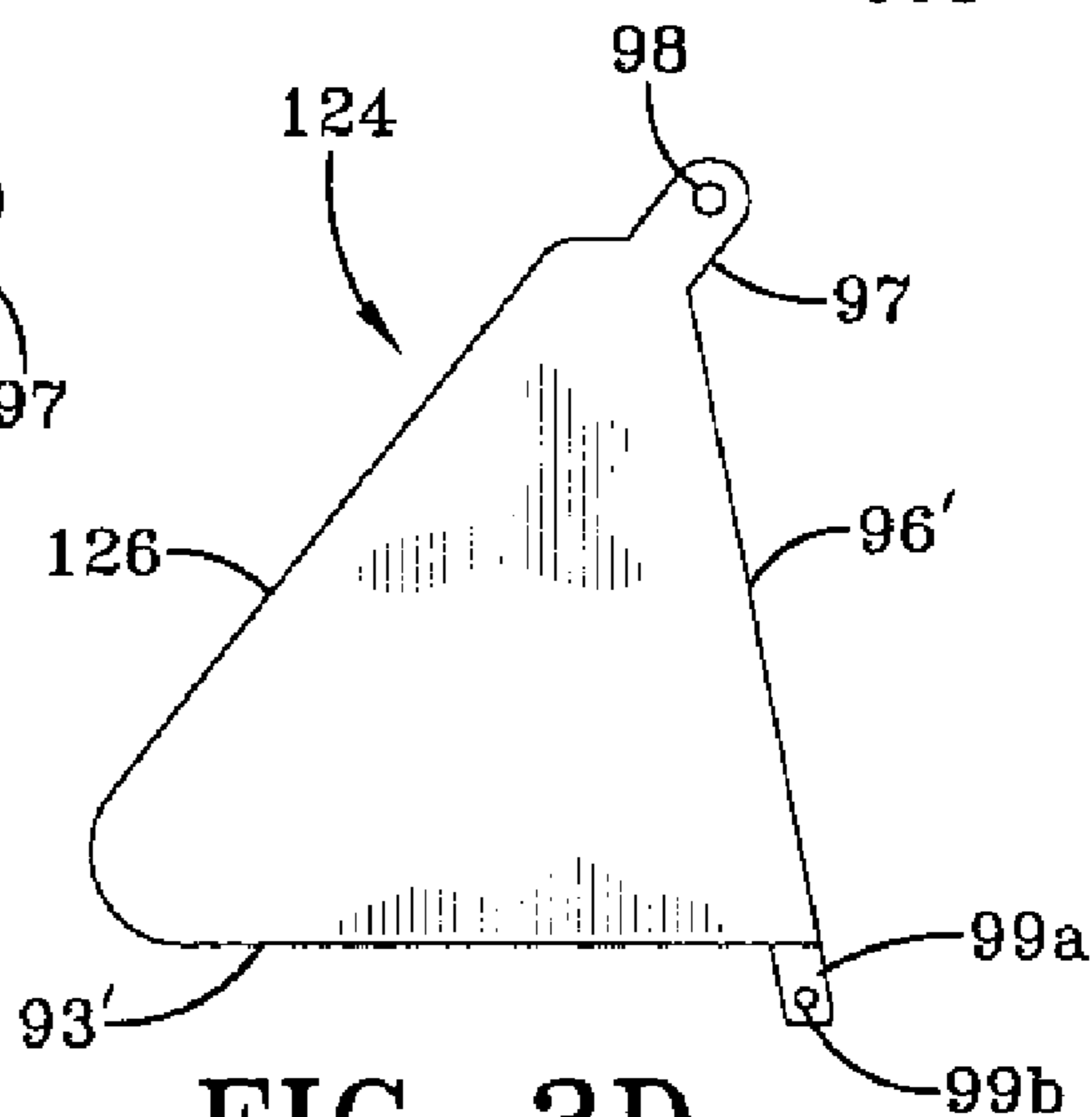

FIG-3D

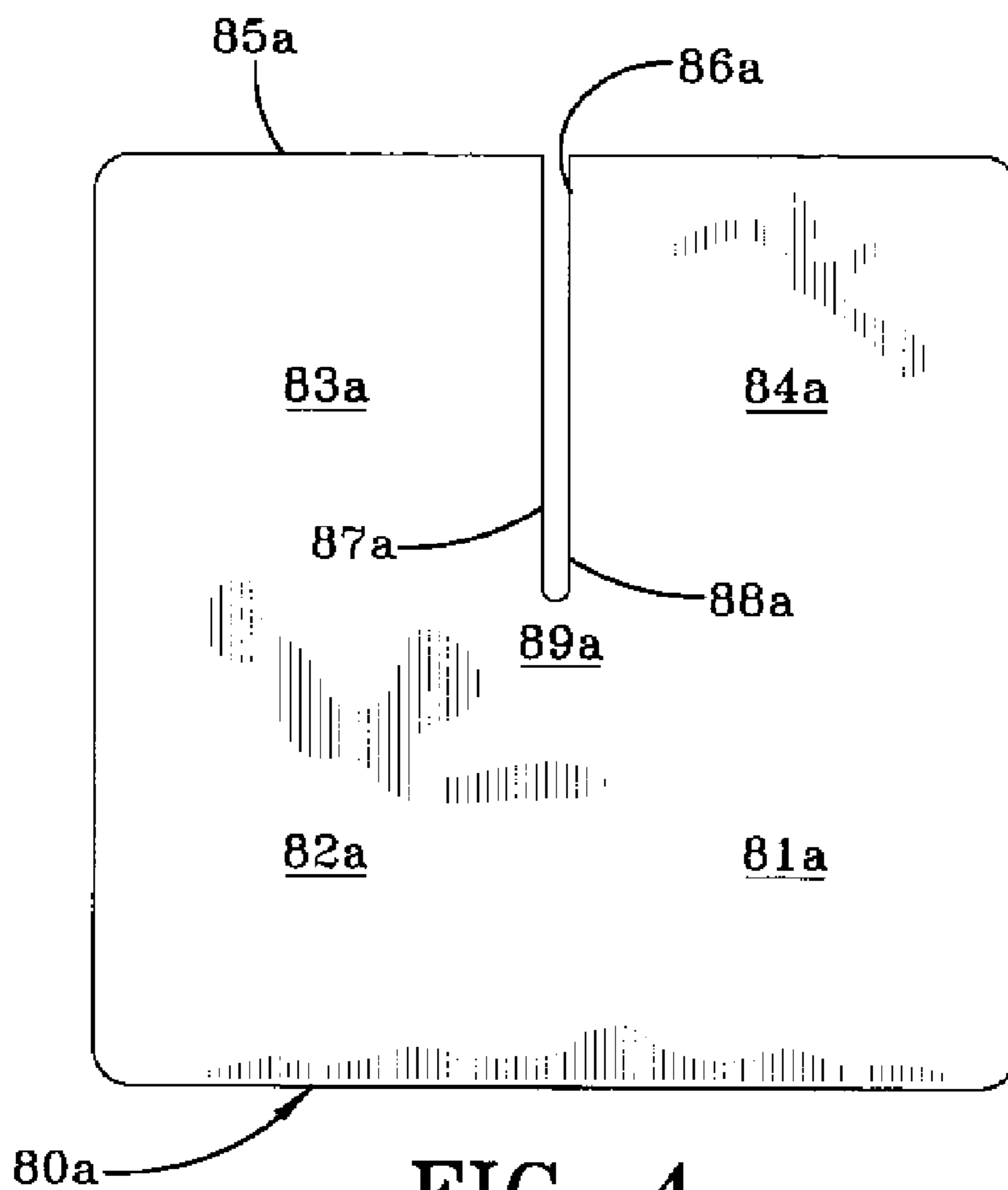

FIG-4

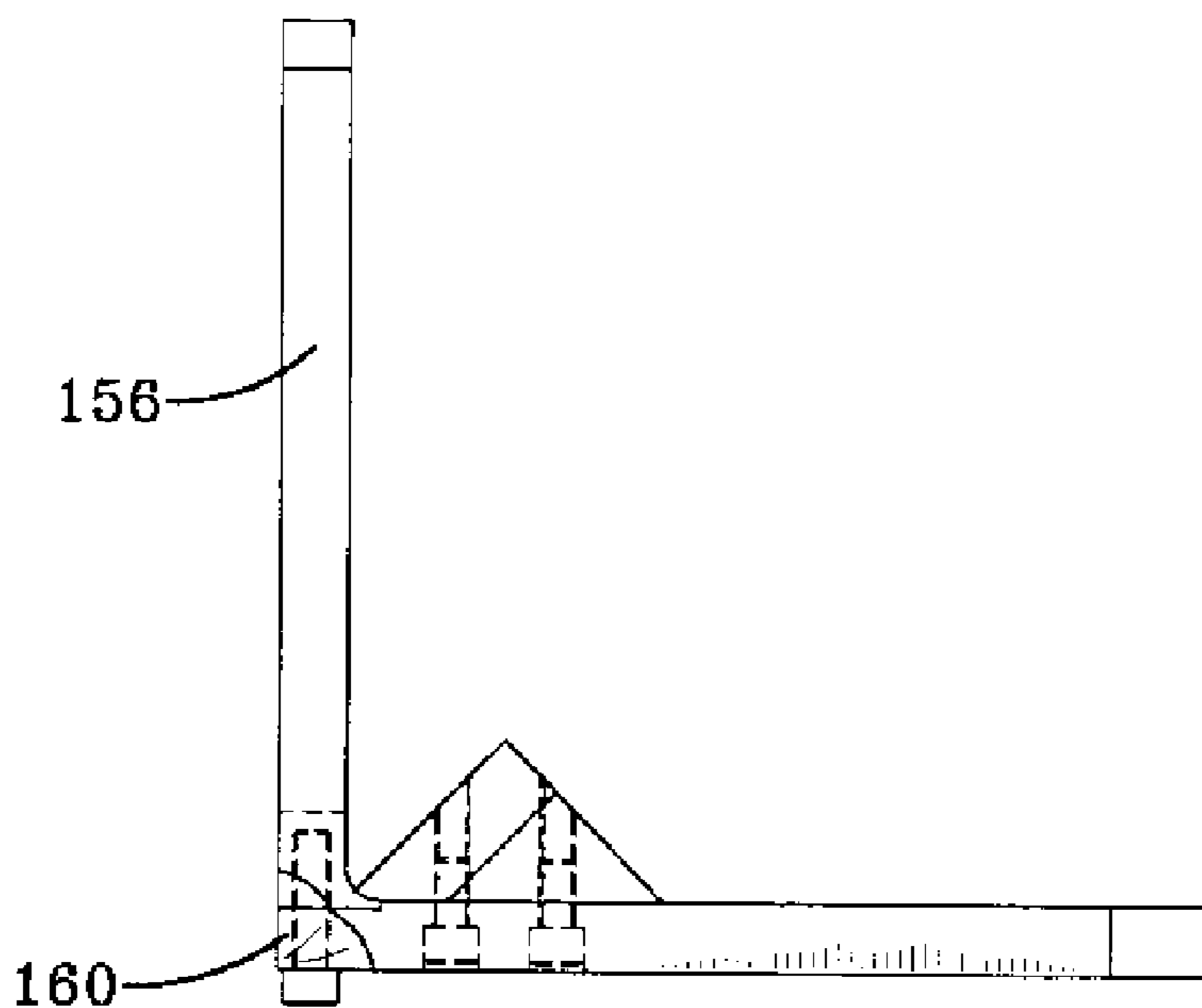

FIG-5

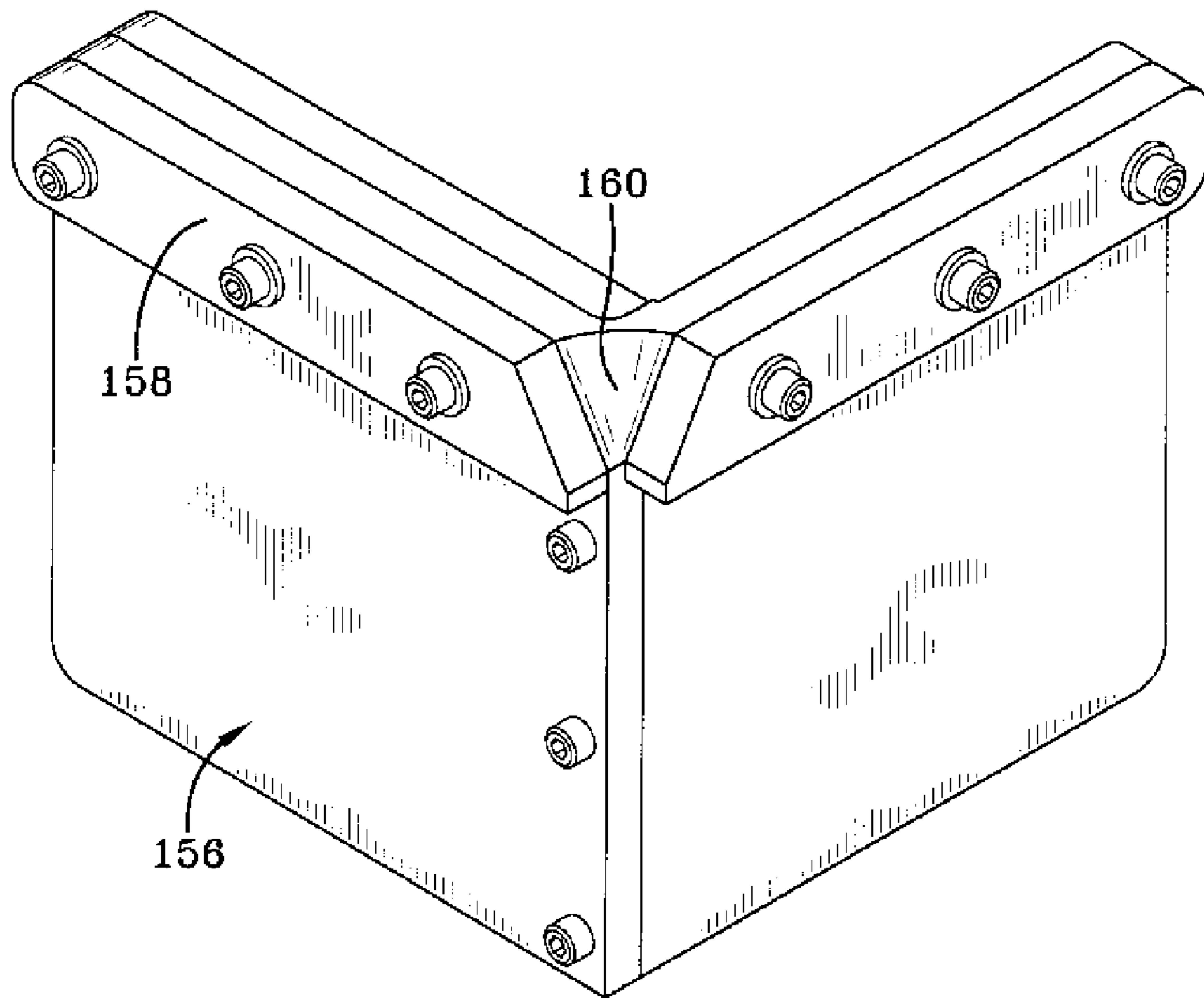

FIG-6

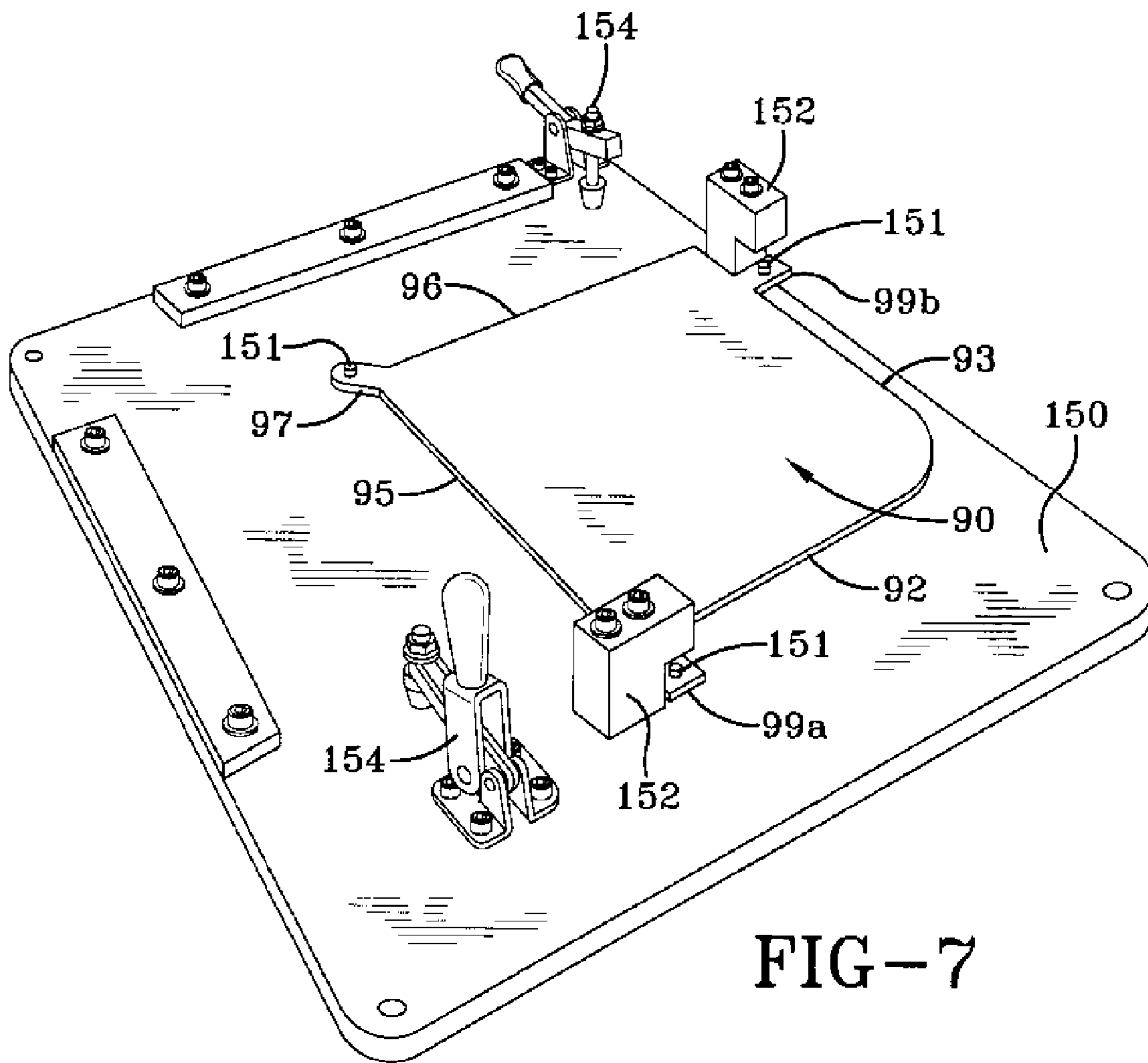
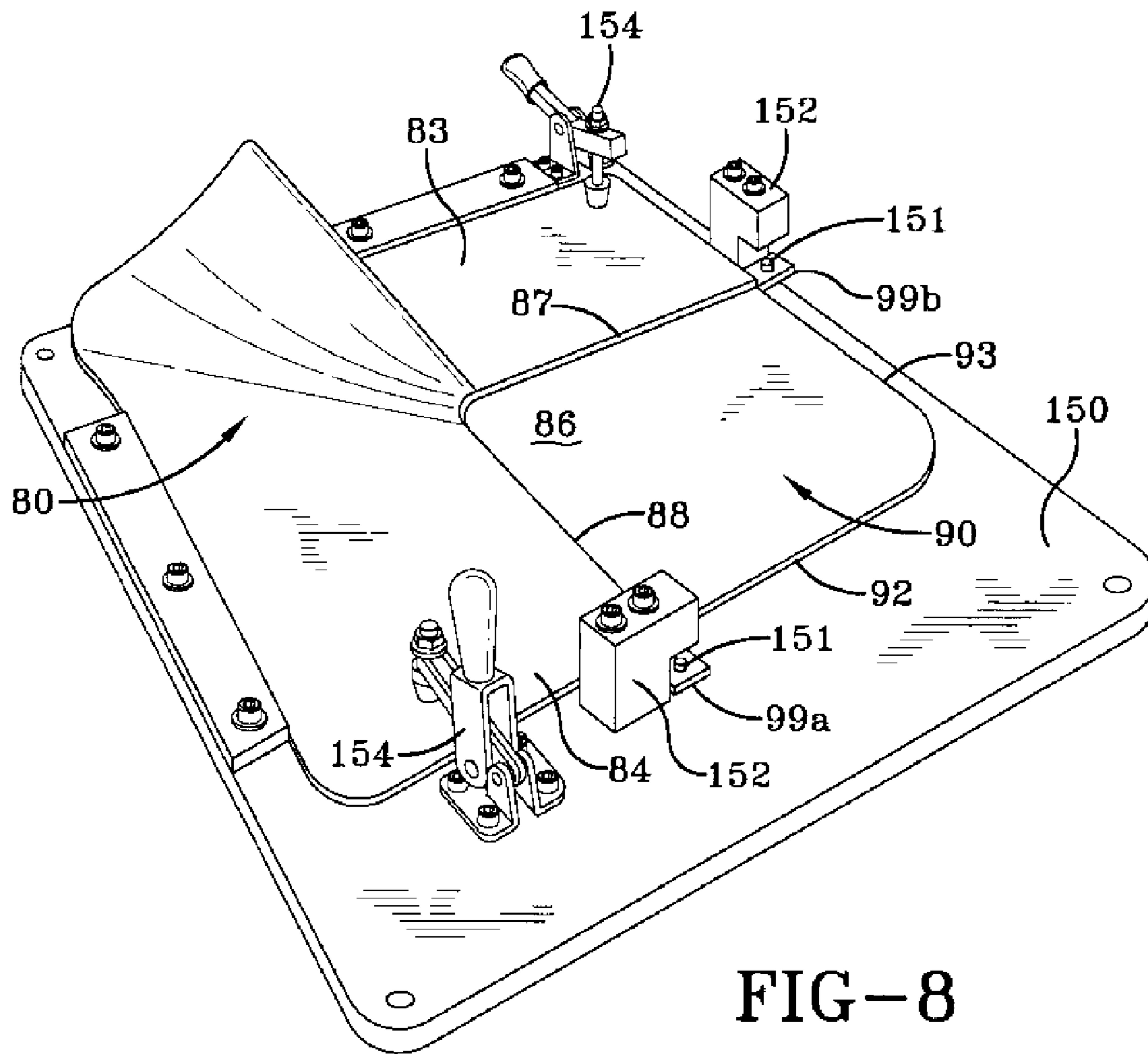
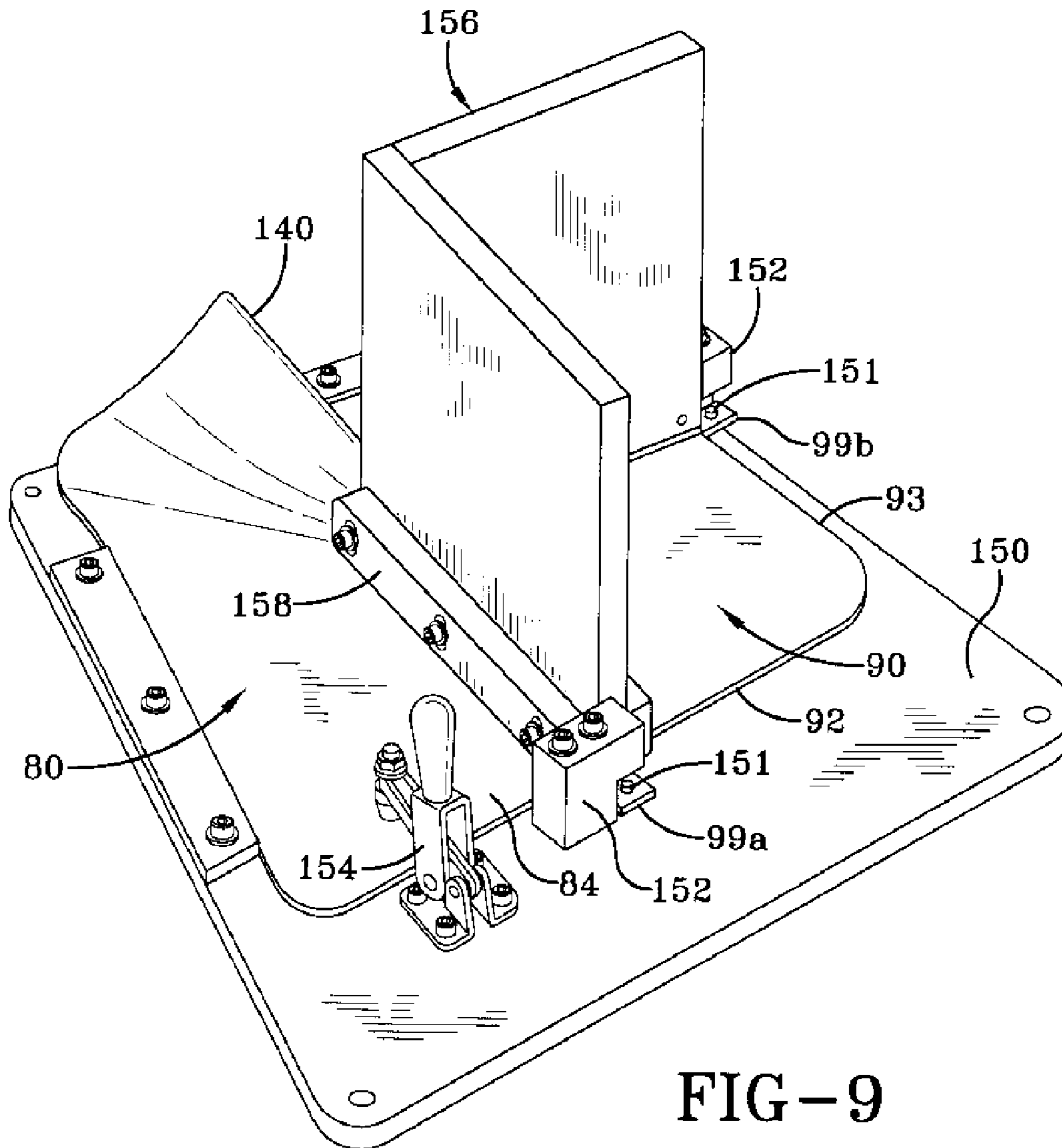

FIG-7





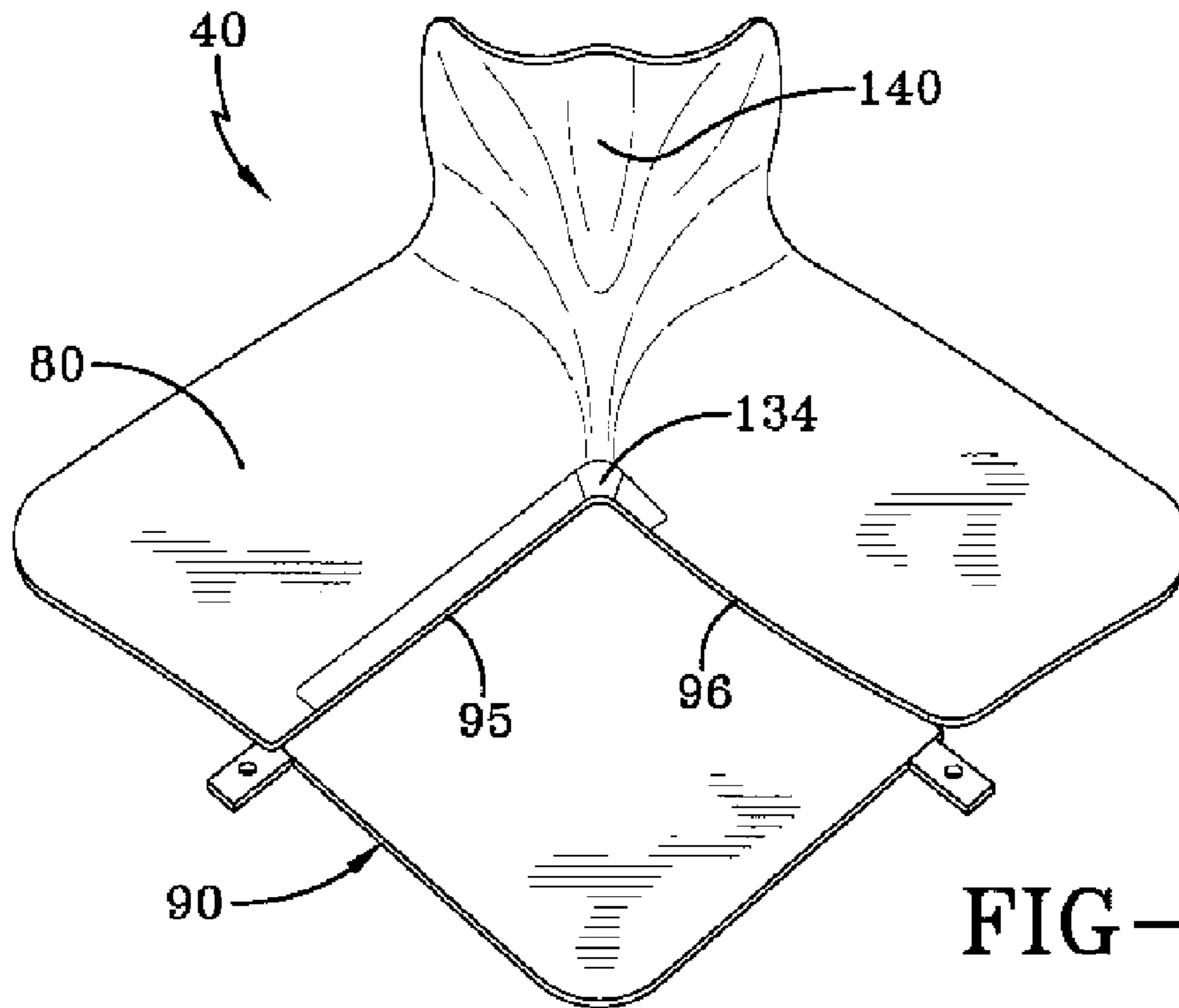

FIG-10

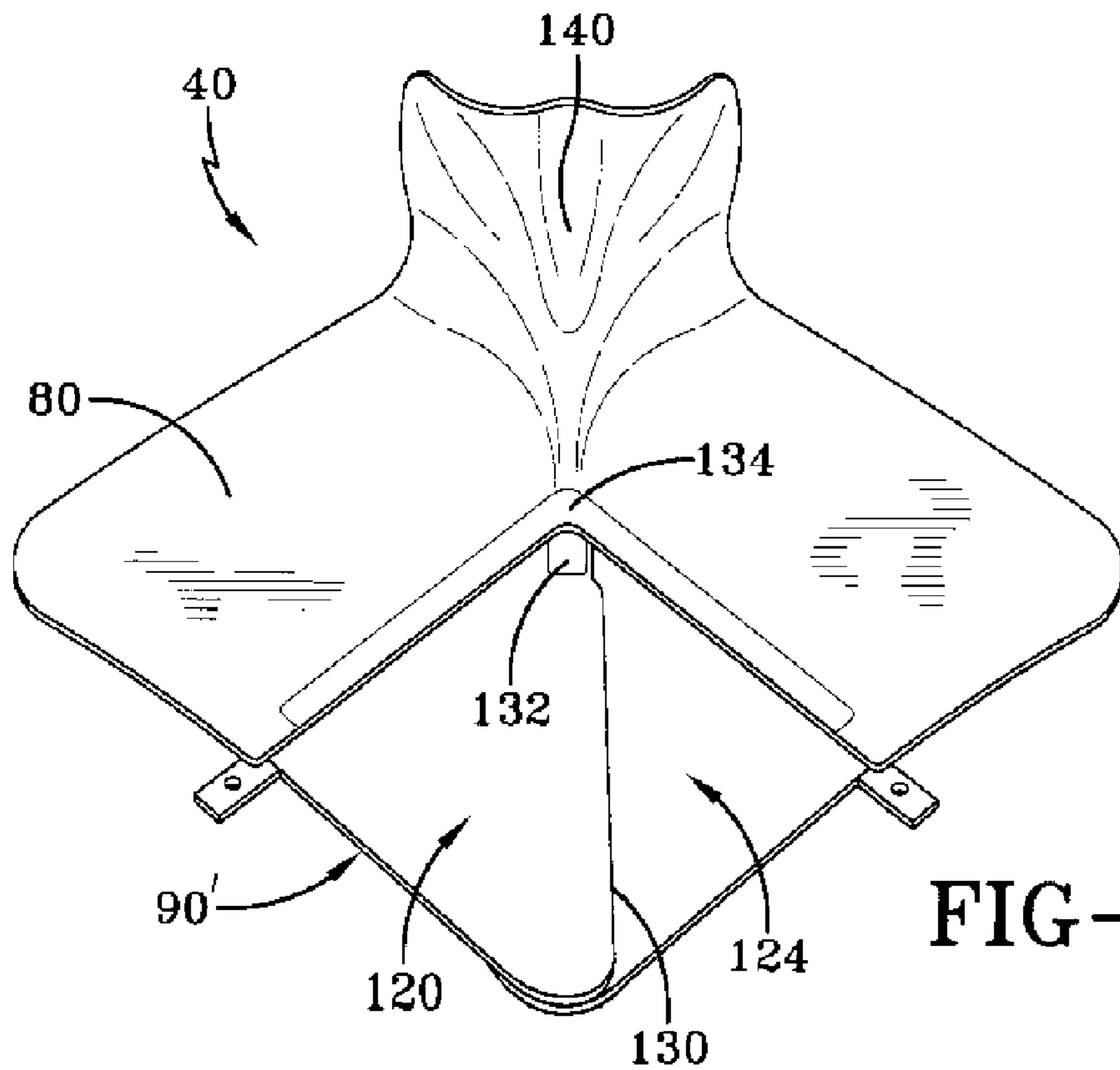

FIG-11

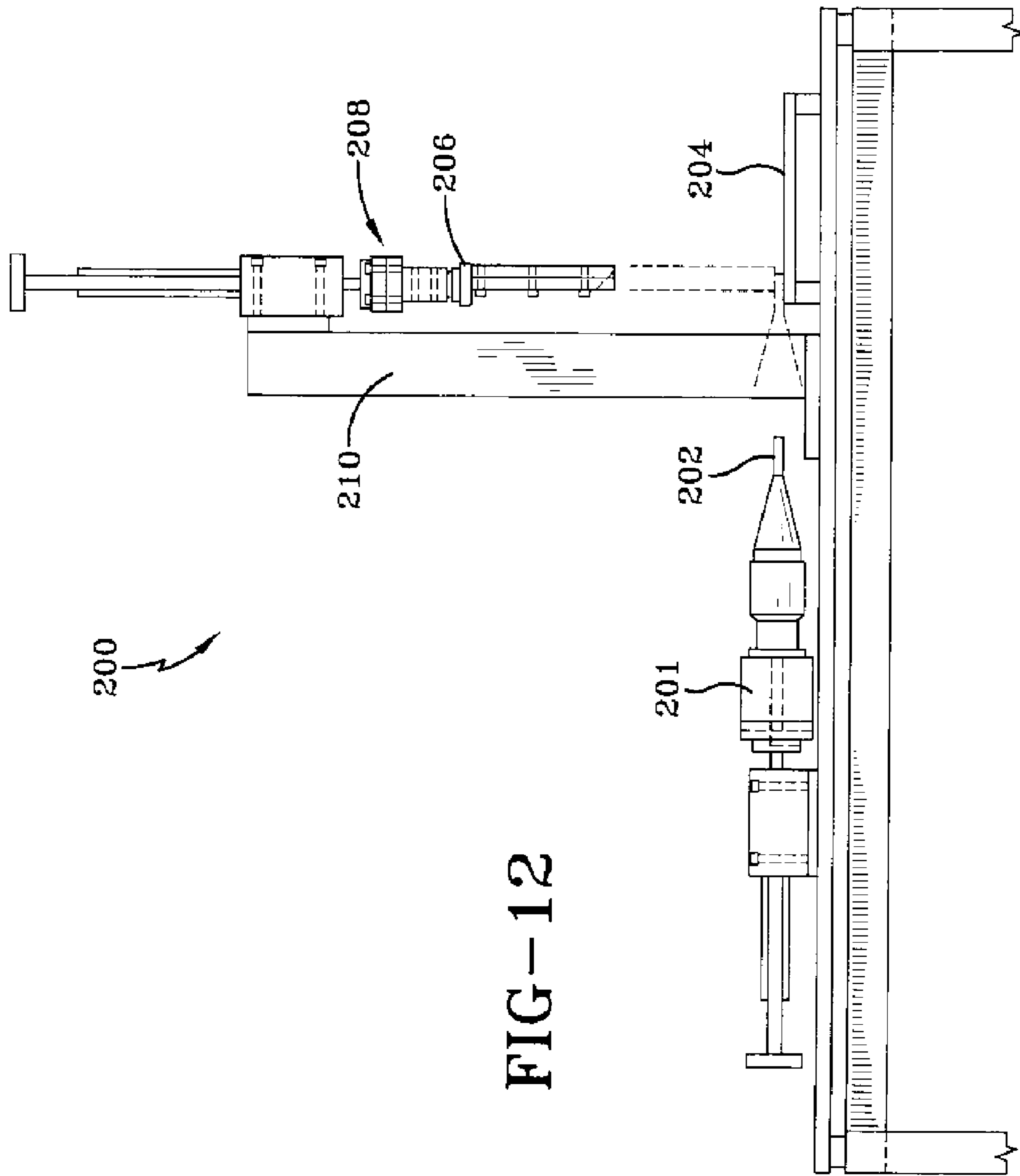

FIG-12

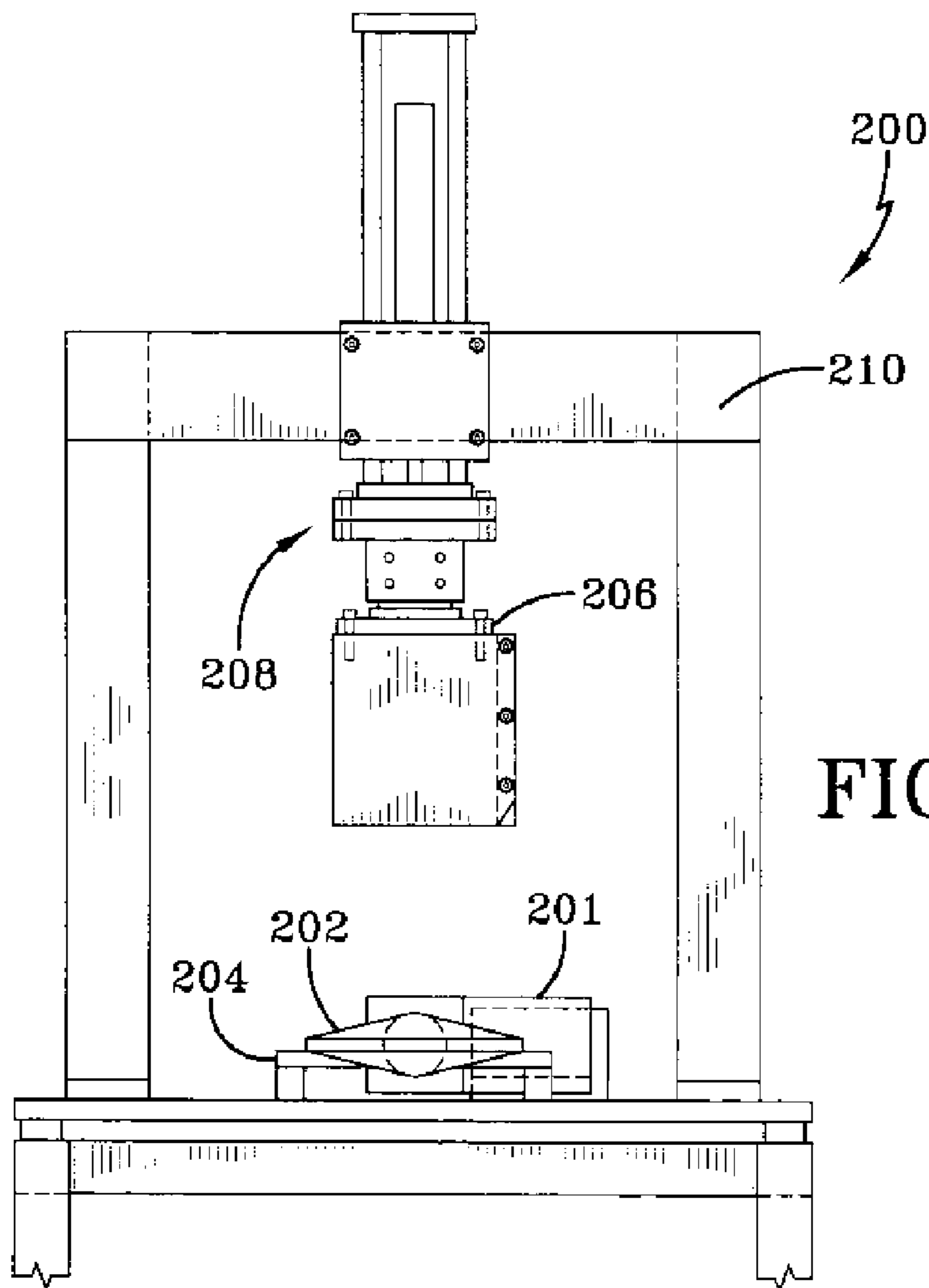

FIG-13

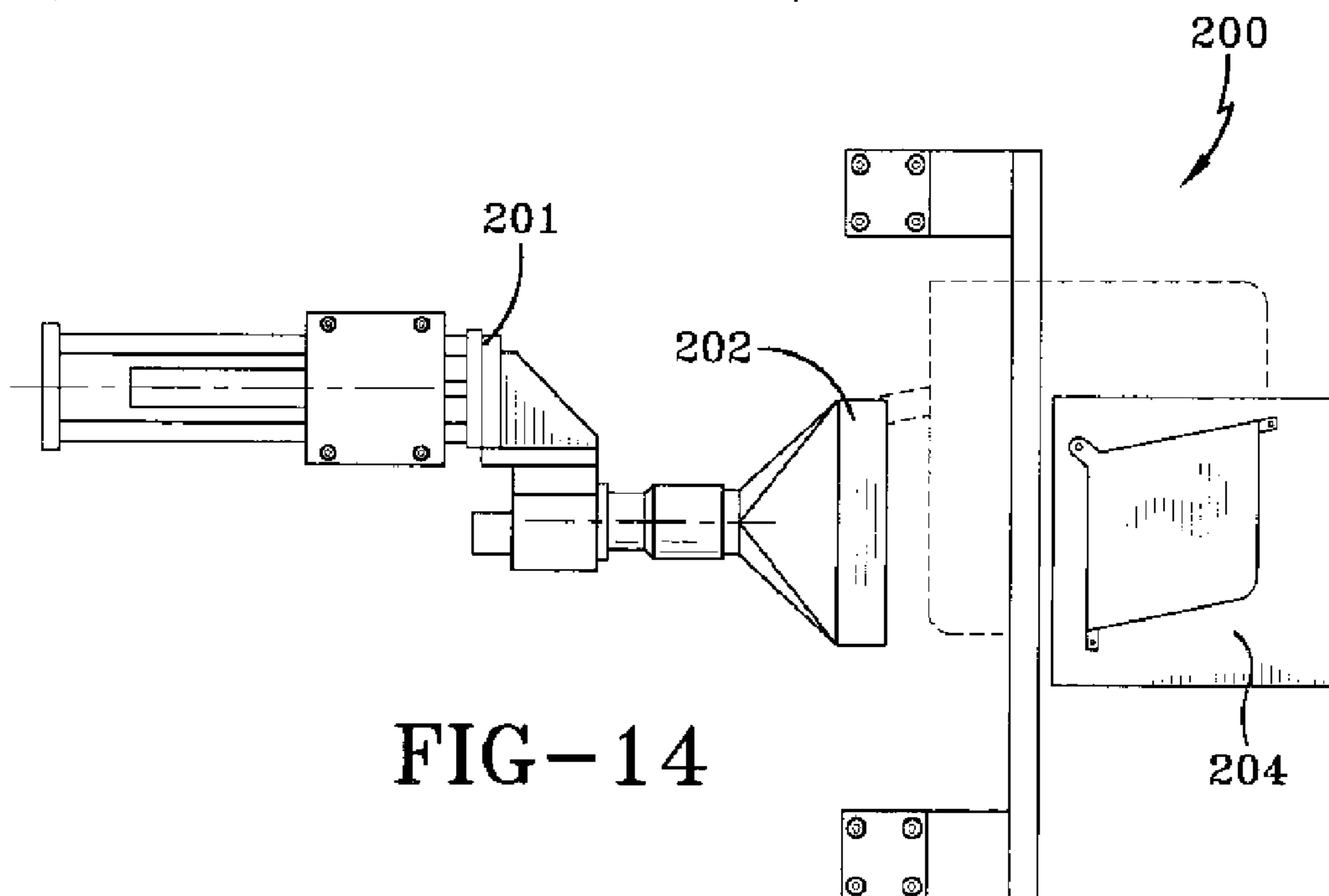

FIG-14

1

**ADJUSTABLE ROOF FITMENT AND
METHOD OF MAKING THE SAME****CROSS REFERENCES TO RELATED
APPLICATIONS**

The present application is a divisional application of U.S. patent application Ser. No. 10/876,827 filed on Jun. 24, 2004, now abandoned which is a continuation of U.S. patent application Ser. No. 10/125,768, filed on Apr. 18, 2002, now U.S. Pat. No. 6,754,993.

TECHNICAL FIELD

The present invention, at least to the extent disclosed in the exemplary embodiments, relates generally to roof-covering membranes, and more particularly, to an adjustable corner fitment and roof membrane system. Polymer-coated membranes may be used to cover substantially flat roofs. The membrane is preferably custom designed for the particular roof on which it is to be used. The roof measurements may be provided to a factory which may create a unitary membrane from separate pieces which have been heat welded together.

**BACKGROUND AND SUMMARY OF THE
INVENTION**

Items such as vents, ductwork, air conditioning units, and the like commonly protrude from the surface of a roof. The size and location of these items is preferably provided to the factory which creates the membrane. With this information, the factory may make provisions for these items in the membrane.

Providing a water-tight seal around a protrusion in a roof presents a number of problems. U.S. Pat. No. 4,872,296 discloses a method and a fitment which have been used to cover the corners of protrusions. The fitment of this patent comprises a first generally rectangular member segment, a side being part-way split interjacent its ends, and a second member segment with a triangularly-shaped corner portion conformed to loop shape and having its marginal edges overlying portions of the first segment contiguous to the split and being welded thereto in a continuous weld seam. This method and fitment work best when the angle of the corner is a right angle and the angle between the roof and the protrusion is a right angle.

In many cases, however, the corner is not a right angle, the protrusion is not at a right angle to the roof, or there is some other irregularity in the protrusion, such as the bottom and the top being different sizes. In these situations, known fitments and methods do not provide satisfactory results. The membrane must be folded or "bunched" in order to conform the membrane to the underlying structure. The folding and bunching is unsightly, and water may collect in the folds which may have deleterious effects on the roofing membrane and/or may lead to localized leaks at seams and at other places in the membrane. In addition, folding can lead to cracking of the roof membrane over time due in part to stress induced by the fold lines. Therefore, a need exists for an adjustable fitment and roof membrane system that provides a smooth transition no matter what the shape or angle of the underlying protrusion and that eliminates the need to fold or bunch the fitment or the roof membrane.

U.S. Pat. No. 5,706,610 provides one embodiment of an adjustable roof membrane which includes a universal fitment and a universal boot. The disclosure of U.S. Pat. No.

2

5,706,610 is hereby incorporated by reference. In this embodiment, the universal fitment has a body with preferably three sides, a tab, and a neck connecting a corner of the body to the tab. The body is preferably either substantially square or substantially triangular. The patent also discloses an embodiment of a universal boot. The universal boot has a generally rectangular section with a split extending vertically in a side, and it has a fitment with a body having at least three sides, a tab, and a neck connecting a corner of the body to the tab. The tab of the fitment is preferably welded to the back of the rectangular section above the split.

U.S. Pat. No. 6,199,326 provides another embodiment of an adjustable roof membrane which includes a universal fitment. The disclosure of U.S. Pat. No. 6,199,326 is hereby incorporated by reference. In this embodiment, the universal fitment is an adjustable corner fitment for a roof. The adjustable corner fitment is comprised of a top membrane and a bottom membrane. The top membrane has a cutout. The cutout extends from a side of the top membrane. The base membrane portion has a first side, a second side, a third side and a fourth side. The first side is connected to the second side at a first angle greater than 90 degrees, and the third side is connected to the fourth side at a second angle greater than 90 degrees. The base membrane portion is conformed to loop shape such that the first side and the second side underlie portions of the top membrane contiguous to the cutout. The first side of the base membrane may be completely welded to the top membrane prior to installation. However, the second side of the base membrane is adjustable relative to the top membrane prior to installation on the roof. Consequently, an installer is able to adjust the corner fitment to a corner in the field to eliminate unnecessary buckling of the corner fitment or the roof membrane. After adjusting the corner fitment to the corner, the installer may then completely weld the second side of the base membrane to the top membrane.

An exemplary embodiment of the present invention provides another adjustable fitment and roof membrane system and a method for making the adjustable fitment and roof membrane system. The fitment may be useful with roof membranes to cover exposed roof areas around a vertical protrusion in a roof. As used herein, a vertical protrusion includes all protrusions that have a vertical component. The fitment may be partially secured to a roof membrane, a boot, and/or a spanning strip prior to being positioned at the corner of a vertical protrusion. Alternatively, the fitment may be positioned independently of the other components at the corner of a vertical protrusion. After the fitment is positioned at the corner of a vertical protrusion, a floating portion of the fitment may be adjusted to fit the corner of the vertical protrusion so that there is minimal or no folding or bunching of the material of the fitment. In this adjusted position, the floating portion of the fitment may be dielectrically welded, hot air bonded or otherwise secured to another portion of the fitment, and the fitment may be finally dielectrically welded, hot air bonded or otherwise secured to the roof membrane, the boot, and/or the spanning strips.

The prefabricated roofing fitment of an exemplary embodiment of the present invention may be made from thermoplastic olefin (TPO), polyvinyl chloride (PVC), or any other suitable material. TPO material is much less expensive than other roof membrane material, but has not been used in the roofing industry in the past because TPO is non-conductive material and therefore, cannot be dielectrically welded. Material such as polyvinyl chloride (PVC) has been commonly used in the roofing industry since it can be easily dielectrically welded. However, PVC is much more

3

expensive than TPO. Accordingly, PVC lends itself to dielectric welding or hot air bonding, while TPO lends itself to hot air bonding. With the hot air bonding apparatus and methods of the exemplary embodiment a fully TPO fitment is achieved.

An exemplary embodiment of the present invention may utilize any material suitable for constructing the fitments claimed herein. Examples of the materials utilized in the embodiments may be comprised of polyvinyl chloride (PVC), thermoplastic olefin (TPO), or rubber, and any mixtures thereof. The exemplary embodiment may be made from or use any material that is heat bondable, glue bondable, or solvent bondable. The exemplary embodiment may be made with or use a material that is compatible with dielectric welding, hot air bonding, solvent fusion, adhesive bonding, heat welding, melt bonding, vibration welding, ultrasonic welding, heat staking, or other methods commonly known to those experienced in the field of this art.

In addition to the novel features and advantages mentioned above, other objects and advantages are achieved, at least in the preferred embodiments, by the invention as shown and described below.

BRIEF DESCRIPTION OF THE DRAWINGS

A better understanding of the invention will be had when reference is made to the appended drawings, wherein identical parts are identified by identical part numbers and wherein:

FIG. 1 is a perspective view of an exemplary embodiment of an adjustable roof membrane system of the present invention;

FIG. 2 is a cross sectional view taken along line 2-2 of FIG. 1;

FIG. 3a is a top plan view of an exemplary embodiment of a base membrane portion;

FIG. 3b is a top plan view of an exemplary embodiment of a base membrane portion which has a middle adjustment feature;

FIGS. 3c and 3d are top plan views of an exemplary embodiment of the two components that form the base membrane portion with a middle adjustment feature of FIG. 3b;

FIG. 4 is a top plan view of an exemplary embodiment of a top membrane portion;

FIG. 5 is a top plan view of an exemplary embodiment of a die used in the method of making a fitment;

FIG. 6 is a perspective view of an exemplary embodiment of a die used in the method of making a fitment;

FIG. 7 is a perspective view of an exemplary embodiment of a base membrane portion secured to a base plate;

FIG. 8 is a perspective view of an exemplary embodiment of a top membrane portion and a base membrane portion secured to a base plate;

FIG. 9 is a perspective view of an exemplary embodiment of a die positioned on a top membrane portion and a flat base membrane portion;

FIG. 10 is a perspective view of an exemplary embodiment of an adjustable corner fitment that is not completely sealed so that it may be adjusted after positioning and then sealed to conform exactly to a specific protrusion, thereby eliminating "buckling" of the fitment or roofing membrane;

FIG. 11 is a perspective view of an exemplary embodiment of an adjustable corner fitment of the present invention that has a middle adjustment feature;

FIG. 12 is a side view of an exemplary embodiment of the apparatus used in hot air bonding;

4

FIG. 13 is an end view of the FIG. 12 apparatus; and FIG. 14 is a top plan view of the FIG. 12 apparatus.

DETAILED DESCRIPTION OF PREFERRED EMBODIMENT(S)

Referring primarily to FIGS. 1 and 2, a polymer-membrane 10 is shown overlying a roof 20. The roof 20 may have a surrounding parapet 22. In addition, a protrusion 30 may extend from the roof 20. An opening 12 in the membrane 10 preferably allows the sides 32, 34 of the protrusion 30 to extend through the membrane 10. After the membrane 10 is in place on the roof 20, a preferred embodiment of a fitment 40 of the present invention may be installed to substantially prevent moisture from entering the roof 20 at a corner of the protrusion 30.

In one embodiment of an adjustable roof membrane system of the present invention, fitments 40 may be joined by spanning strips 50 as shown in FIG. 1. Each spanning strip 50 preferably has an upper portion 52 and a bottom portion 54. The bottom portion 54 may be dielectrically welded, hot air bonded or otherwise sealed along its length to the membrane 10, and the fitments 40 may be dielectrically welded, hot air bonded or otherwise sealed to the membrane 10 and the spanning strips 50 as shown at 60, 62, and 70. Although not shown in the figures, it should also be recognized that the fitments 40 may be positioned at the corners of a vertical protrusion such that they are overlapped by the spanning strips 50.

A fitment 40 preferably has a top membrane portion 80 and a base membrane portion 90. As illustrated in FIG. 4, the top membrane portion 80 is preferably substantially rectangular and may be comprised of quadrants 81, 82, 83, and 84. The top membrane portion 80 has a cutout 86. The cutout 86 preferably divides quadrant 83 from quadrant 84, and it preferably extends from about the middle of side 85 to about the center portion 89 of the top membrane portion 80. As shown in FIG. 4, the cutout 86 may have substantially parallel sides 87, 88. For one example of the cutout 86, the sides 87, 88 may be separated by about one-half inch. However, the cutout 86 may increase in width as the cutout 86 extends from the center portion 89 towards the side 85.

In addition to the embodiment shown in FIG. 4, the top membrane portion 80 may take the form of many different shapes. The shape of the top membrane portion 80 may vary depending on the application. For example, the top membrane portion 80 may have a different number of sides, it may have curved sides, or it may have sides of different lengths. For another example, the cutout 86 may extend from a portion of a side other than the middle, it may extend at an angle which is not perpendicular, or it may have a different shape, length, or width.

Referring back to the embodiment of the adjustable roof membrane system shown in FIG. 1, quadrants 81, 82 of the top membrane portions 80 and upper portions 52 of the spanning strips 50 may be secured by an adhesive or other suitable means to the sides 32, 34 of the protrusion 30. A band 100 may be used to join the top edges of quadrants 81, 82 and upper portions 52. In addition, an adhesive, a bead of mastic, a bead of sealant, or any similar material may be used to form a tight seal between the band 100 and the sides 32, 34 of the protrusion 30.

Referring to FIG. 3a, the base membrane portion 90 is preferably comprised of a first generally triangular portion 91, a second generally triangular portion 94, and a tab 97 which has a hole 98. Sides 92, 93 of the first generally triangular portion 91 are preferably joined at a radiused

5

corner. In addition, sides **92**, **93** extend at an angle *a* which is greater than about 90 degrees. On the other hand, sides **95**, **96** of the second generally triangular portion **94** are connected by the tab **97**. The sides **95**, **96** extend at an angle *b* which is greater than about 90 degrees. By making the angles *a*, *b* greater than about 90 degrees, the fitment **40** is preferably adjustable. In other words, the angles *a*, *b* preferably help to substantially eliminate the need to fold or bunch the fitment **40** when the corner is not a right angle, when the protrusion **30** is not at a right angle to the roof **20**, or when there is some other irregularity in the protrusion **30**.

However, the base membrane portion **90** is not limited to the configuration as described above. The base membrane portion **90** may have any other shape that is suitable and may have side tabs **99a**, which may have a hole **99b**, on the corner between side **92** and side **95** and/or the corner between side **93** and side **96**.

In another exemplary embodiment, the base membrane portion **90'** may be comprised of two separate triangular shaped portions **120**, **124**, as shown in FIGS. **3b-3d**. The first triangular shaped portion **120** may preferably be comprised of three sides **95'**, **92'**, **122**, a tab **97** which may have a hole **98**, and a side tab **99a** which may have a hole **99b**. Side **95'** and side **122** are preferably connected by a tab **97**, while side **95'** and side **92'** are preferably connected by a side tab **99a**. The second triangular shaped portion **124** may preferably be comprised of three sides **96'**, **93'**, **126**, a tab **97** which may have a hole **98**, and a side tab **99a** which may have a hole **99b**. Side **96'** and side **126** are preferably connected by a tab **97**, while side **96'** and side **93'** are preferably connected by a side tab **99a**. In an exemplary embodiment, the first triangular shaped portion **120** and the second triangular shaped portion **124** are arranged to form a base membrane portion **90'**.

The base membrane portion **90'** may be substantially similar to base membrane portion **90**. However, base membrane portion **90'** has a middle adjustment feature **130** which allows the fitment **40** to be adjusted when sides **95'** and **96'** are sealed to the top membrane portion **80**. The middle adjustment feature **130** is preferably formed by the overlapping of side **122** on the first triangular shaped portion **120** and side **126** on the second triangular shaped portion **124**.

An exemplary method of making a fitment **40** begins by placing the base membrane portion **90** on a base plate **150** so that it is substantially flat, as shown in FIG. **7**. The base membrane portion **90** may be held in place by any type of securing device. However, in an exemplary embodiment, the base membrane portion **90** may be held in place on the base plate **150** by placing the holes **98**, **99b** on the tab **97** and the sides tabs **99a** over the pegs **151** located on the base plate **150**. Next, the top membrane portion **80** may be placed over the base membrane portion **90**, as shown in FIG. **8**. The side **87** of the cutout **86** of the top membrane portion **80** may overlap the side **96** of the base membrane portion **90**, while the side **88** of the cutout **86** of the top membrane portion **80** may overlap the side **95** of the base membrane portion **90**.

The top membrane portion **80** may be held in place on the base plate **150** by any type of securing device **154**. In an exemplary embodiment, the top membrane portion **80** may be held in place by a securing device **154** which may press the quadrant **83** of the top membrane portion **80** against the base plate **150** and another securing device **154** which may press the quadrant **84** of the top membrane portion **80** against the base plate **150**, as shown in FIG. **8**.

Once the base membrane portion **90** and the top membrane portion **80** are secured in place on the base plate **150**, the portions **80**, **90** may be sealed. One exemplary method

6

of sealing portions **80** and **90** may be by dielectric welding. In order to weld, a die **156** may be placed on the overlapping portion of the top membrane portion **80** and base membrane portion **90**, as shown in FIG. **9**. In an exemplary embodiment, the die **156** may be L-shaped. However, the die **156** may have any suitable configuration to conform to the type of seal that is desired. Also, the die **156** may be any width that may accomplish a seal. However, the width of the die **156** may preferably correspond with the width of the seal that is desired.

The die **156** used for dielectric welding may also contain non-conductive strips **158** on the bottom of the die **156**. These non-conductive strips **158** may be made from any material that is not conductive. The non-conductive strips **158** may be in any configuration that will enable the desired seal to be achieved. The non-conductive strips **158** prevent the heat from the radio frequency electric field during dielectric welding from being generated in the areas of the base membrane portion **90** or top membrane portion **80** that are not to be sealed, thereby controlling the location of the seal.

Another exemplary embodiment provides for, once the die **156** is in place, a heat source to be placed in contact with the die **156**. Heat may be transferred from the heat source through the die **156** to the top membrane portion **80** and the base membrane portion **90**, thereby forming a weld. Non-conductive strips may comprise part of the die **156**, thereby controlling the location of the seal between the top membrane portion **80** and the base membrane portion **90**.

Another exemplary method of sealing the top and base membrane portions **80** and **90** may be by hot air bonding. Once the top membrane portion **80** and the base membrane portion **90** are secured to the base plate **150**, as shown in FIG. **8**, hot air may be inserted between the edges of the overlapping portions **80**, **90**. Specifically, hot air may be inserted between overlapping side **88** of the top membrane portion **80** and side **95** of the base membrane portion **90** and/or hot air may be inserted between overlapping side **87** of the top membrane portion **80** and side **96** of the base membrane portion **90**, or any other desired configuration.

The insertion of hot air may be done manually or by any type of suitable apparatus. An exemplary embodiment of an apparatus for inserting the hot air for hot air bonding is shown in FIGS. **12-14**. The hot air insertion apparatus **200** may contain a base **204**, a heat gun **201** with nozzle **202**, a vertical support member **210**, and a vertical retractable arm **208** with a connecting element **206**. A base membrane portion **90** may be secured to the base **204** so that it is substantially flat, while a top membrane portion **80** may be held in place by the connecting element **206** at the end of the vertical retractable arm **208**. The vertical support member **210** holds the vertical retractable arm **208** substantially above the base **204**.

Once the base membrane portion **90** is secured on the base **204** and the top membrane portion **80** is secured by the connecting element **206** on the vertical retractable arm **208**, the vertical retractable arm **208** may be lowered until the top membrane portion **80** is just above the base membrane portion **90** on the base **204**. In an exemplary embodiment, the vertical retractable arm **208** may be lowered so that the top membrane portion **80** is about a half-inch above the base membrane portion **90** on the base **204**. Next, the heat gun **201** may extend horizontally toward the base **204** until the nozzle **202** is substantially in between the overlapping portions (sides) of the top membrane portion **80** and the base membrane portion **90**. The nozzle **202** emits hot air from the heat gun **201** to the substantially overlapping areas of the top

and base membrane portions **80**, **90** that are to be bonded together. The nozzle **202** emits hot air for a sufficient amount of time to enable the membrane portions **80**, **90** to be bonded together.

After the heat gun **201** emits hot air, via the nozzle **202**, for a sufficient amount of time, the heat gun **201** may retract horizontally away from the base **204**. Then the connecting element **206** on the vertical retracting arm **208** presses down on the top membrane portion for a determined amount of time then releases the top membrane portion **80** and retract upwards. Next, a die may be placed on the overlapping portion of the top membrane portion **80** and base membrane portion **90**—in order to provide a pressure over the weld being formed by the fusion of the respective heated sections of portions **80** and **90**. The die **156** may be shaped as shown in FIG. 9. The die may remain in place for a sufficient amount of time to allow the membrane portions **80**, **90** to be bonded together, thereby forming the fitment **40** having a hot air bond.

In another preferred embodiment, the fitment **40** may be made according to the methods described above. However, the base membrane portion **90** may be a base membrane portion **90'**. This base membrane portion **90'** may be comprised of two triangular shaped portions **120**, **124**. This base membrane portion **90'** has a middle adjustment feature **130** which allows the fitment **40** to be adjusted around a protrusion **30** when sides **95'** and **96'** are sealed to the top membrane portion **80** prior to installation. In an exemplary embodiment, the middle adjustment feature **130** may have a partially sealed portion **132** extending from the radius **134** of the fitment **40**. This partially sealed portion **132** is preferably about a half-inch in length, but can be any suitable length. FIG. 11 illustrates a fitment **40** with a middle adjustment feature **130**.

Various sizes and shapes of dies **156** may be used to correspond to the type of seal that may be desired. For example, prior to installation, only one side **95**, **96** may be completely sealed, only the tab **97** may be completely sealed, or both sides **95**, **96** may be completely sealed. If both sides **95**, **96** are not completely sealed prior to installation, the unsealed sides **95** and/or **96** may be sealed after installation of the fitment **40**.

Additionally, the die **156** that is used to make the present fitment **40** may contain a concave cutout portion **160** on the bottom corner, as shown in FIG. 6. This concave cutout portion **160** forces the pucker at **140** (to the extent a pucker develops) of the top membrane portion **80** to be substantially located in the center of the top membrane portion **80** at the radius **134**. This concave cutout portion **160** provides a pucker **140** that is consistently in the same place, i.e., the center of the top membrane portion **80** at the radius **134**, as shown in FIGS. 10 and 11 where it will not cause structural integrity problems.

An example of a fitment **40** prior to installation is shown in FIGS. 10 and 11. In an exemplary embodiment, preferably only one of the sides **95**, **96** may be completely sealed to the top membrane portion **80** prior to installation on the roof **20**. Preferably, only a portion, if any at all, of the other side **95**, **96** may be sealed to the top membrane portion **80** prior to installation. This preferably enables the fitment **40** to be adjusted in the field to a corner that is not a right angle, a protrusion **30** that is not at a right angle to a roof **20**, and/or an irregularly-shaped protrusion **30**. In a fitment **40** that has a middle adjustment feature **130**, both sides **95'** and **96'** are sealed to the top membrane portion **80** prior to installation. However, the middle adjustment feature **130** is not sealed prior to installation and enables the fitment **40** to be adjusted

in the field to the corner or protrusion **30** on the roof **20**. It should be noted that after sealing, the base membrane portion **90** remains substantially flat.

After the fitment **40** is adjusted to the roof **20** and to the protrusion **30** in the field to substantially eliminate any folding or bunching, the unsealed side **95** and/or **96** may be sealed along its entire length to the top membrane portion **80** or the middle adjustment feature **130** may be sealed.

Those skilled in the art should also recognize that the top membrane portion **80** may be sealed to the base membrane portion **90** prior to installation so that sides **95**, **96** may both be adjusted in the field. For one example, the top membrane portion **80** may be sealed only to the tab **97** of the base membrane portion **90** prior to installation. For another example, the top membrane portion **80** may be sealed only to the tab **97** and a limited portion of one or each side **95**, **96** of the base membrane portion **90** prior to installation. For another example, the top membrane portion **80** may be sealed to both sides **95'**, **96'** so that the middle adjustment feature **130** may be adjusted in the field.

The die **156** used in forming the fitment **40** of an exemplary embodiment may be made of various types of material that is suitable to conducting heat. In an exemplary embodiment, the die **156** may be made of various metals, including but not limited to, steel and aluminum. The non-conductive strips **158** on the die **156** may be made of various types of material that is non-conductive such as, but not limited to, rubber.

Other embodiments of an adjustable roof membrane system may also exist. The fitments **40** may be used in conjunction with a universal boot such as the one disclosed in U.S. Pat. No. 5,706,610. The fitments **40** may be adjusted and secured to the corners of the protrusion **30**. A boot may be placed around the protrusion **30** and over the fitments **40**. The boot may then be sealed to the fitments **40**. For another example, a boot may first be placed around and secured to the protrusion **30**. The fitments **40** may be placed around the corners of the protrusion **30** such that they overlap the boot. The fitments **40** may then be adjusted and sealed to the boot.

In an exemplary embodiment the fitment **40** may be made from thermoplastic olefin (TPO), polyvinyl chloride (PVC) and any other suitable material. TPO material is much less expensive than other roof membrane material, but has not been used in the roofing industry in the past because TPO is non-conductive material and therefore, cannot be dielectrically welded. Material such as polyvinyl chloride (PVC) has been commonly used in the roofing industry since it can be easily dielectrically welded. However, PVC is much more expensive than TPO. TPO material may be used because it may be easily and efficiently hot air bonded to form a seal, as described above. Additionally, using TPO material greatly reduces the cost associated with the adjustable fitments and roof membrane system. PVC material may be because it may easily be dielectrically welded or hot air bonded. Accordingly, PVC and any other suitable material may be used in the method(s) of forming a fitment **40** that use dielectric welding or hot air bonding, while TPO and any other suitable material may be used in the method(s) of forming a fitment **40** that use hot air bonding.

PVC, TPO and other suitable material may be used when the assembly of the component portions of the fitment **40** uses a mode for attachment other than hot air bonding and dielectric welding, such as caulking or adhesives. The preferred embodiments herein disclosed are not intended to be exhaustive or to unnecessarily limit the scope of the invention. The preferred embodiments were chosen and described in order to explain the principles of the present invention so

9

that others skilled in the art may practice the invention. Having shown and described preferred embodiments, those skilled in the art will realize that many variations and modifications may be made to affect the described invention. Many of those variations and modifications will provide the same result and fall within the spirit of the claimed invention. It is the intention, therefore, to limit the invention only as indicated by the scope of the claims.

What is claimed is:

1. A method of making an adjustable corner fitment, comprising the steps of:

placing a base membrane portion on a base, wherein said base membrane portion is substantially flat;

aligning a top membrane portion with said base membrane portion, wherein said alignment creates an overlapping area between said top membrane portion and said base membrane portion, while said base membrane portion remains substantially flat; and

sealing a portion of said overlapping area of said top membrane portion and said base membrane portion, wherein a portion of said fitment remains adjustable.

2. The method of claim 1, wherein said seal is made by dielectric welding.

3. The method of claim 1, wherein said seal is made by hot air bonding.

4. The method of claim 1, wherein said overlapping alignment creates a radiused corner.

5. The method of claim 4, wherein said sealing a portion of said overlapping alignment area of said top membrane portion and said base membrane portion comprises the steps of:

placing a die over said overlapping alignment area to be sealed, wherein said die is made from material that is conductive, wherein said die has a bottom corner which has a concave cutout, wherein said concave cutout portion is aligned with said radiused corner; and

adding a heat source, wherein said heat source is in contact with said die, wherein heat is conducted through said die to said overlapping alignment area of said top membrane portion and said base membrane portion, thereby forming a seal that is a dielectric weld at the overlapping alignment area of said top membrane portion and said base membrane portion.

6. The method of claim 4 wherein said sealing a portion of said overlapping alignment area of said top membrane portion and said base membrane portion comprises the steps of:

inserting a hot air source in between said overlapping alignment area of said top membrane portion and said base membrane portion for a sufficient amount of time; removing said hot air source from in between said overlapping alignment area of said top membrane portion and said base membrane portion; and

placing a die over said overlapping alignment area, wherein said die has a bottom corner which has a concave cutout portion, wherein said concave cutout portion is aligned with said radiused corner, wherein said die remains in place until said overlapping alignment area bonds together, thereby forming a seal that is a hot air bond at the overlapping alignment area of said top membrane portion and said base membrane portion.

7. The method of claim 4, wherein said sealing a portion of said overlapping alignment area of said top membrane portion and said base membrane portion comprises the steps of:

10

inserting an adhesive material in between said overlapping alignment area of said top membrane portion and said base membrane portion; and

placing a die over said overlapping alignment area, wherein said die has a bottom corner which has a concave cutout portion, wherein said concave cutout portion is aligned with said radiused corner, wherein said die remains in place until said overlapping alignment area bonds together, thereby forming a seal at the overlapping alignment area of said top membrane portion and said base membrane portion.

8. The method of claim 1, wherein said alignment is made by overlapping a first side of a cutout on said top membrane portion with a first side of said base membrane portion and overlapping a second side of said cutout on said top membrane portion with a second side of said base membrane portion.

9. The method of claim 8, wherein said overlapping alignment creates a radiused corner.

10. The method of claim 9, wherein said sealing a portion of said overlapping area of said top membrane portion and said base membrane portion comprises the steps of:

placing a die over said overlapping area to be sealed, wherein said die is made from material that is conductive, wherein said die has a bottom corner which has a concave cutout portion, wherein said concave cutout portion is aligned with said radiused corner; and

adding a heat source, wherein said heat source is in contact with said die, wherein heat is conducted through said die to said overlapping area of said top membrane portion and said base membrane portion, thereby forming a seal that is a dielectric weld at the overlapping area of said top membrane portion and said base membrane portion.

11. The method of claim 9, wherein said sealing a portion of said overlapping area of said top membrane portion and said base membrane portion comprises the steps of:

inserting a hot air source in between said overlapping area between said top membrane portion and said base membrane portion for a sufficient amount of time; removing said hot air source from in between said overlapping area between said top membrane portion and said base membrane portion; and

placing a die over said overlapping area, wherein said die has a bottom corner which has a concave cutout portion, wherein said concave cutout portion is aligned with said radiused corner, wherein said die remains in place until said overlapping area bonds together, thereby forming a seal that is a hot air bond at the overlapping area of said top membrane portion and said base membrane portion.

12. The method of claim 9, wherein said radiused corner is greater than 90 degrees.

13. The method of claim 9, wherein said radiused corner is 90 degrees or less.

14. The method of claim 1, further comprising placing said fitment around a protrusion to be sealed.

15. The method of claim 14, further comprising adjusting said fitment around said protrusion to be sealed.

16. The method of claim 15, further comprising sealing said remaining adjustable portion of said overlapping area of said top membrane portion and said base membrane portion.

17. The method of claim 16, further comprising sealing said fitment to said protrusion and a roof membrane.

18. The method of claim 1, wherein said seal is made between a first side of a cutout on said top membrane portion with a first side of said base membrane portion, and a second

11

side of said cutout on said top membrane portion and a second side of said base membrane portion remains adjustable.

19. The method of claim **1**, wherein said seal is made between a first side of a cutout on said top membrane portion 5 with a first side of said base membrane portion and said seal

12

is made between a second side of said cutout on said top membrane portion and a second side of said base membrane portion, and a middle adjustment feature remains adjustable.

* * * * *