



US007335080B2

(12) **United States Patent**
Arias

(10) **Patent No.:** **US 7,335,080 B2**
(45) **Date of Patent:** ***Feb. 26, 2008**

(54) **COLLAPSIBLE FLOTATION DEVICE**

(75) Inventor: **David A. Arias**, Virginia Beach, VA
(US)

(73) Assignee: **Kelsyus, LLC**, Virginia Beach, VA
(US)

(*) Notice: Subject to any disclaimer, the term of this patent is extended or adjusted under 35 U.S.C. 154(b) by 0 days.

This patent is subject to a terminal disclaimer.

(21) Appl. No.: **11/554,197**

(22) Filed: **Oct. 30, 2006**

(65) **Prior Publication Data**

US 2007/0066163 A1 Mar. 22, 2007

Related U.S. Application Data

(63) Continuation of application No. 11/143,703, filed on Jun. 3, 2005, now Pat. No. 7,134,930, which is a continuation of application No. 10/847,339, filed on May 18, 2004, now Pat. No. 7,147,528, which is a continuation of application No. 10/295,906, filed on Nov. 18, 2002, now Pat. No. 7,097,524, which is a continuation of application No. 09/772,739, filed on Jan. 30, 2001, now Pat. No. 6,485,344.

(60) Provisional application No. 60/238,988, filed on Oct. 10, 2000.

(51) **Int. Cl.**
B63C 9/08 (2006.01)
B63B 35/58 (2006.01)

(52) **U.S. Cl.** 441/131; 441/40

(58) **Field of Classification Search** 441/131
See application file for complete search history.

(56) **References Cited**

U.S. PATENT DOCUMENTS

722,801 A	3/1903	Bourne, Jr.
772,690 A	10/1904	Baswitz
856,279 A	6/1907	Moore
1,190,743 A	7/1916	Fageol
1,479,903 A	1/1924	Erland
1,960,474 A	5/1934	Browne
2,119,023 A	5/1938	Pickard
2,173,963 A	9/1939	Eubank
2,190,566 A	2/1940	Julian
2,207,025 A	7/1940	Rison
2,334,924 A	11/1943	Hansen
2,344,010 A	3/1944	Walsh

(Continued)

FOREIGN PATENT DOCUMENTS

EP 0974293 1/2000

(Continued)

OTHER PUBLICATIONS

Swimways Corp., v. Overbreak, LLC, Order, Case No. 1:04cv627, dated Jan. 18, 2005.

(Continued)

Primary Examiner—Jesús D Sotelo

(57) **ABSTRACT**

A device comprises a spring and a sleeve. The spring is configured to form a closed loop. The spring is moveable between a coiled configuration when the spring is collapsed and an uncoiled configuration when the spring is expanded. The spring defines a circumference while in the uncoiled configuration. The spring is disposed within the sleeve.

20 Claims, 5 Drawing Sheets

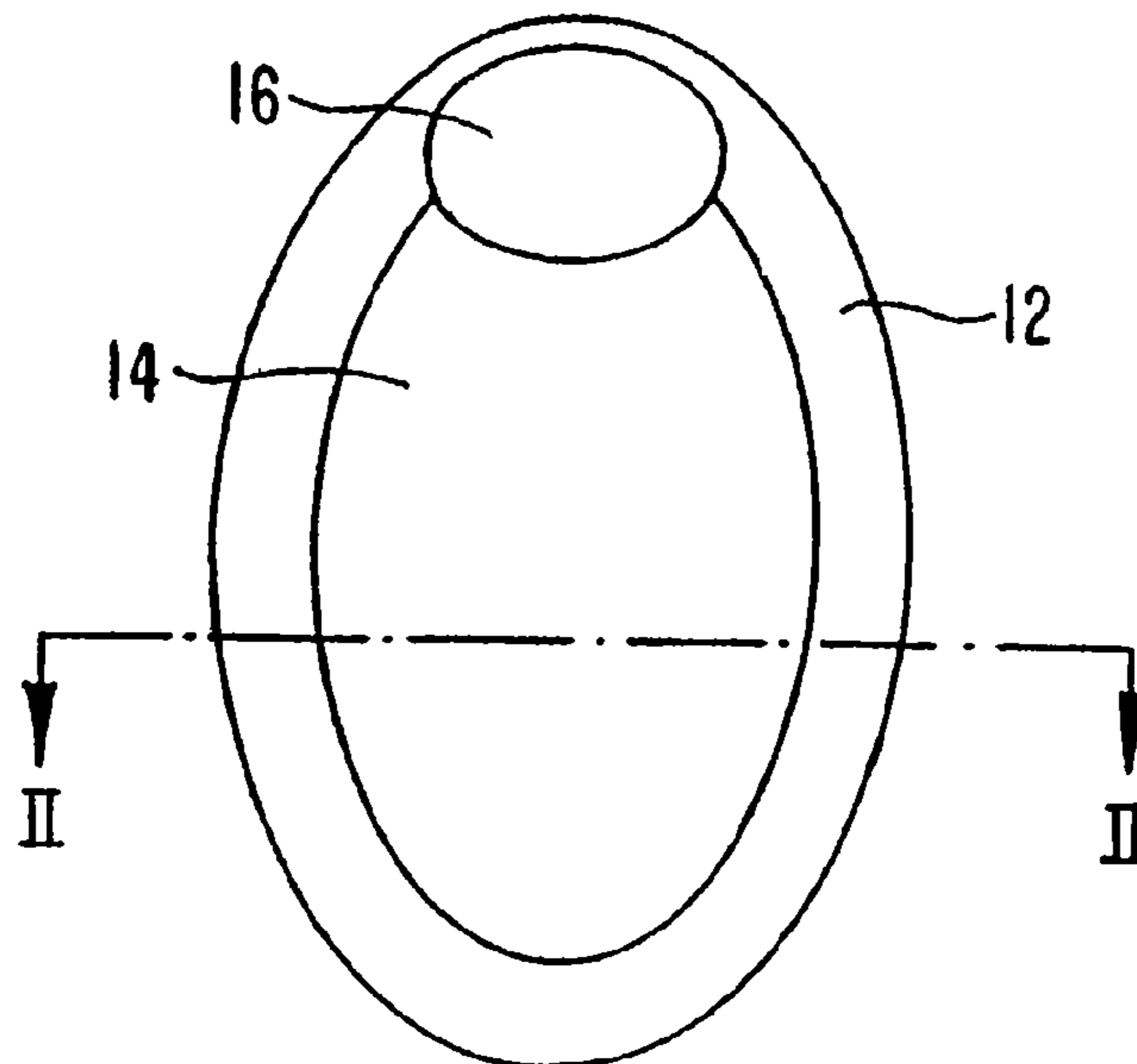

U.S. PATENT DOCUMENTS

2,357,789 A	9/1944	Levy	5,396,917 A	3/1995	Hazinski et al.
2,360,715 A	10/1944	Perry	5,430,980 A	7/1995	Ferrier
2,420,344 A	5/1947	Alexander	5,433,433 A	7/1995	Armell
2,442,105 A	5/1948	Vacheron	5,435,025 A	7/1995	Gerard et al.
2,637,861 A	5/1953	Kethledge	5,454,643 A	10/1995	Sullivan
2,731,997 A	1/1956	Muth et al.	5,467,794 A	11/1995	Zheng
2,803,291 A	8/1957	Meyer	D366,177 S	1/1996	Dean
2,803,839 A	8/1957	Mosley	5,520,561 A	5/1996	Langenohl
2,870,464 A	1/1959	Lalick	5,533,653 A	7/1996	Kaufman
2,953,184 A	9/1960	Erstad	5,560,385 A	10/1996	Zheng
3,052,895 A	9/1962	Lo Vico	5,571,036 A	11/1996	Hannigan
3,336,610 A	8/1967	Geddings	5,579,799 A	12/1996	Zheng
3,339,218 A	9/1967	Stamberger	5,592,961 A	1/1997	Chin
3,602,930 A	9/1971	Channon	D378,772 S	4/1997	Hall
3,775,782 A	12/1973	Rice et al.	5,618,110 A	4/1997	Sullivan
3,842,454 A	10/1974	Young	5,618,246 A	4/1997	Zheng
3,860,976 A	1/1975	Suyama	5,619,759 A	4/1997	Hansen et al.
3,862,876 A	1/1975	Graves	RE35,571 E	7/1997	McLeese
3,960,161 A	6/1976	Norman	5,644,807 A	7/1997	Battistella
3,990,463 A	11/1976	Norman	5,688,052 A	11/1997	Compton
4,097,944 A	7/1978	Yulish	5,693,398 A	12/1997	Granger
4,200,942 A	5/1980	Case	D389,362 S	1/1998	Boulatian
4,231,125 A	11/1980	Tittl	5,718,612 A	2/1998	Elsholz
D261,464 S	10/1981	Smith	5,729,846 A	3/1998	Sullivan
4,296,788 A	10/1981	Slater	5,730,529 A	3/1998	Fritz et al.
4,435,236 A	3/1984	Inae et al.	5,810,695 A	9/1998	Sass
4,478,587 A	10/1984	Mackal	D400,749 S	11/1998	Bechtold, Jr.
4,512,049 A	4/1985	Henry	5,885,123 A	3/1999	Clifford
4,561,480 A	12/1985	Underwood et al.	5,976,023 A	11/1999	Cho
4,576,375 A	3/1986	Roberts	6,030,300 A	2/2000	Zheng
4,709,430 A	12/1987	Nicoll	D425,357 S	5/2000	Waring
4,766,918 A	8/1988	Oderkirk	D426,415 S	6/2000	Le Gette et al.
4,815,784 A	3/1989	Zheng	6,073,283 A	6/2000	Zheng
4,825,892 A	5/1989	Norman	6,113,453 A	9/2000	Stuffelbeam
4,858,634 A	8/1989	McLeese	6,170,100 B1	1/2001	Le Gette et al.
4,861,300 A	8/1989	Casagrande et al.	6,192,635 B1	2/2001	Zheng
4,942,838 A	7/1990	Boyer et al.	6,223,673 B1	5/2001	Mears et al.
4,944,707 A	7/1990	Silverglate	6,225,940 B1	5/2001	Ohlsen
4,946,067 A	8/1990	Kelsall	6,276,979 B1	8/2001	Saltel
4,951,333 A	8/1990	Kaiser et al.	D447,661 S	9/2001	Le Gette et al.
4,976,642 A	12/1990	Wilkie	D449,193 S	10/2001	Le Gette et al.
4,986,781 A	1/1991	Smith	6,343,391 B1	2/2002	Le Gette et al.
5,024,262 A	6/1991	Huang	6,478,038 B1	11/2002	Le Gette et al.
5,038,812 A	8/1991	Norman	6,485,344 B2	11/2002	Arias
5,045,011 A	9/1991	Lovik	6,634,040 B2	10/2003	Le Gette et al.
5,056,172 A	10/1991	Kaiser et al.	7,097,524 B2	8/2006	Arias
5,059,463 A	10/1991	Peters	7,134,930 B2	11/2006	Arias
5,070,807 A	12/1991	Lewis	7,147,528 B2	12/2006	Arias
5,088,723 A	2/1992	Simmons	2003/0068940 A1	4/2003	Arias
D325,489 S	4/1992	Pratt			
5,116,273 A	5/1992	Chan			
5,123,869 A	6/1992	Schipmann			
D328,324 S	7/1992	Wang			
5,163,192 A	11/1992	Watson			
5,163,461 A	11/1992	Ivanovich et al.			
5,186,667 A	2/1993	Wang			
5,206,964 A	5/1993	Wilson, Sr.			
5,213,147 A	5/1993	Zheng			
5,261,131 A	11/1993	Kilby			
5,299,331 A	4/1994	Badillo			
D349,593 S	8/1994	Hensley			
5,334,067 A	8/1994	Henry et al.			
5,345,627 A	9/1994	Cammarata			
5,358,440 A	10/1994	Zheng			
5,385,518 A	1/1995	Turner			

FOREIGN PATENT DOCUMENTS

EP	1 008 706 A2	6/2000
FR	2697421	11/1992
GB	258077	9/1926
JP	48-024199 U	3/1973
JP	52-002895 U	1/1977
JP	1-133961 U	9/1989
JP	4-065567 U	6/1992

OTHER PUBLICATIONS

Swimways Corp., v. Overbreak, LLC, Memorandum Opinion, Case No. 1:04cv627, dated Jan. 21, 2005.
 Merriam-Websters Collegiate Dictionary (10th ed. 1998) pp. 190, 337, 598.
 "How to Fold a Bicycle Tire," <http://www.rideyourbike.com/tirefold.html>, pp. 1-2.

FIG. 1

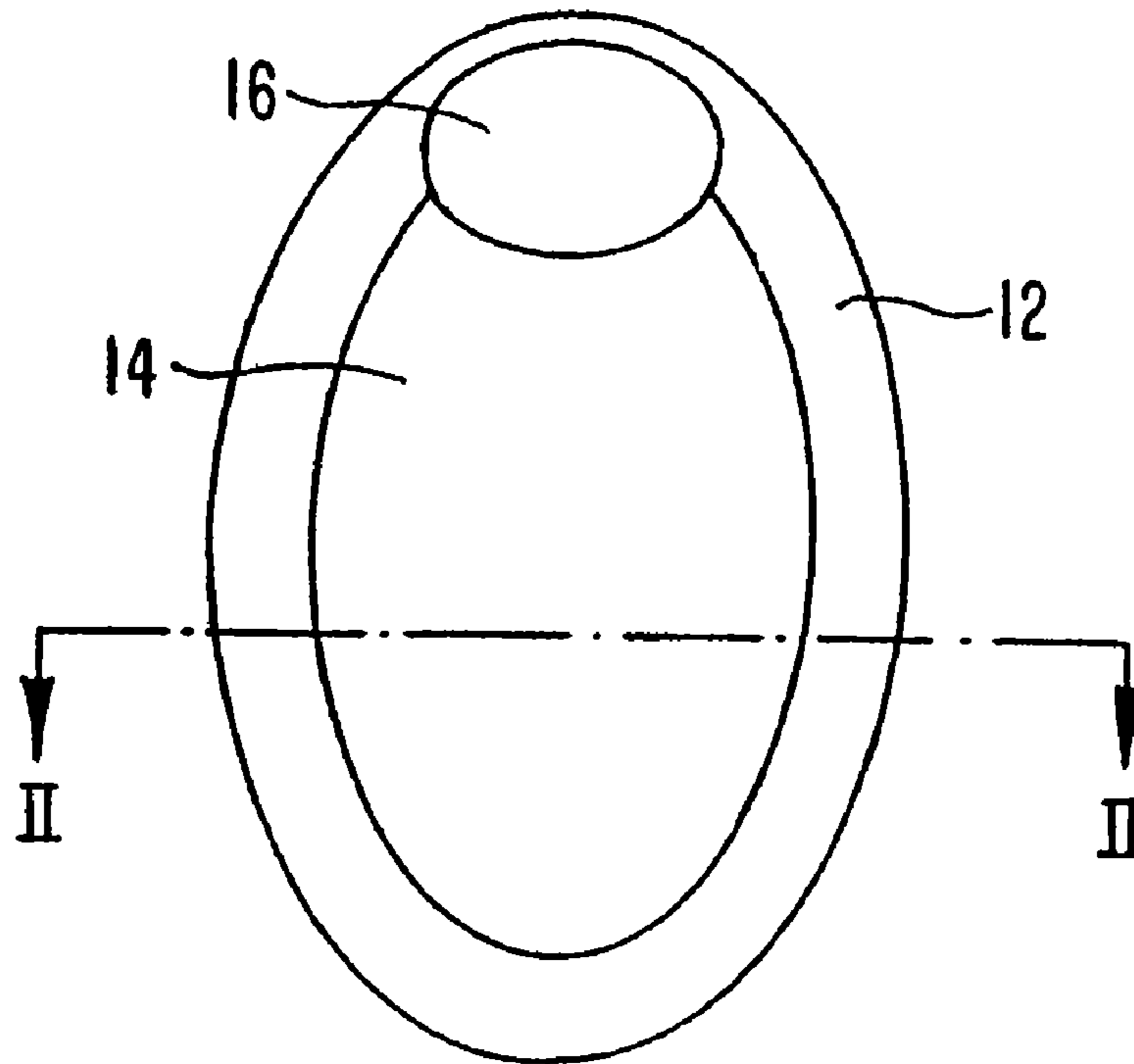

FIG. 2

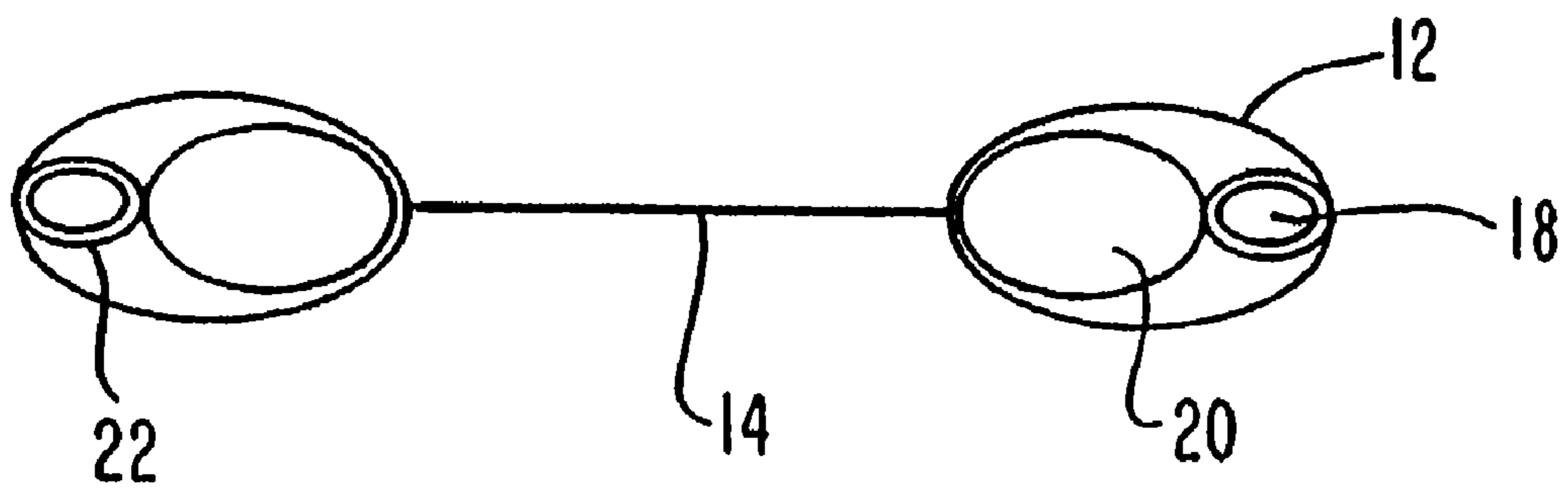

FIG. 3

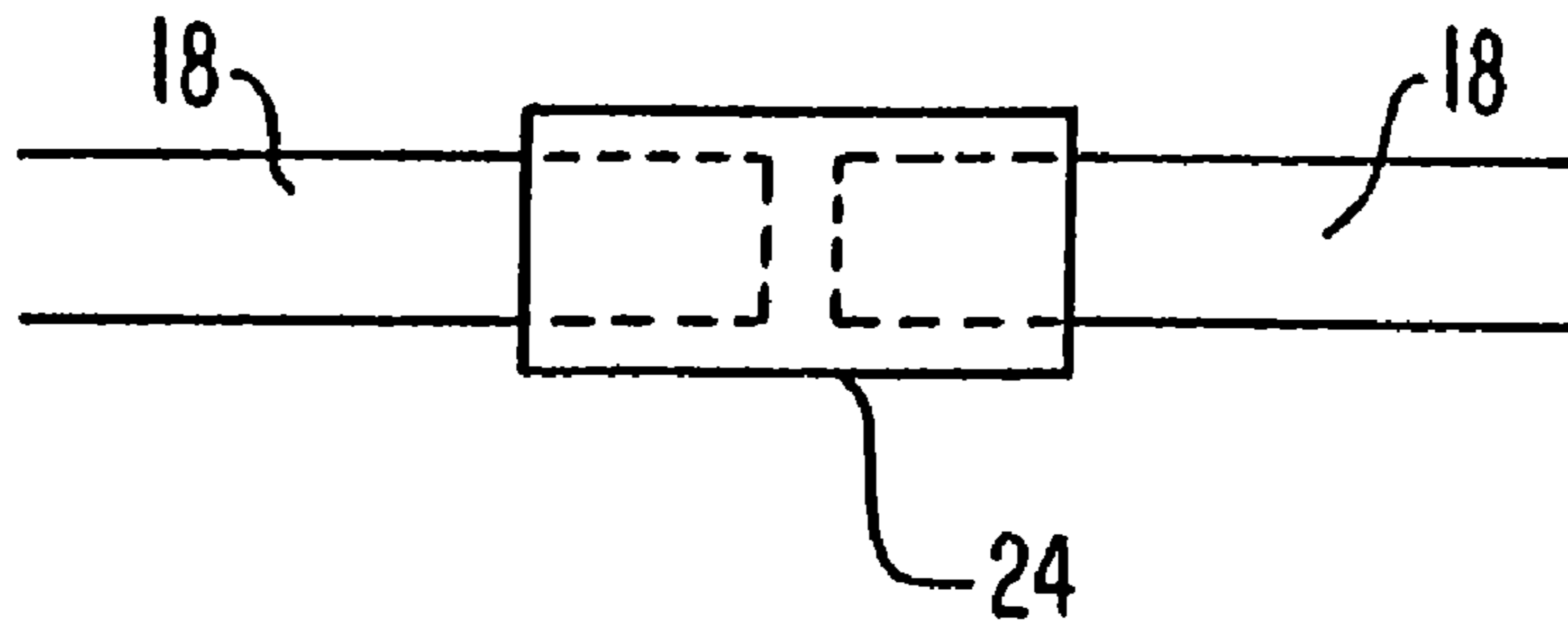

FIG. 4

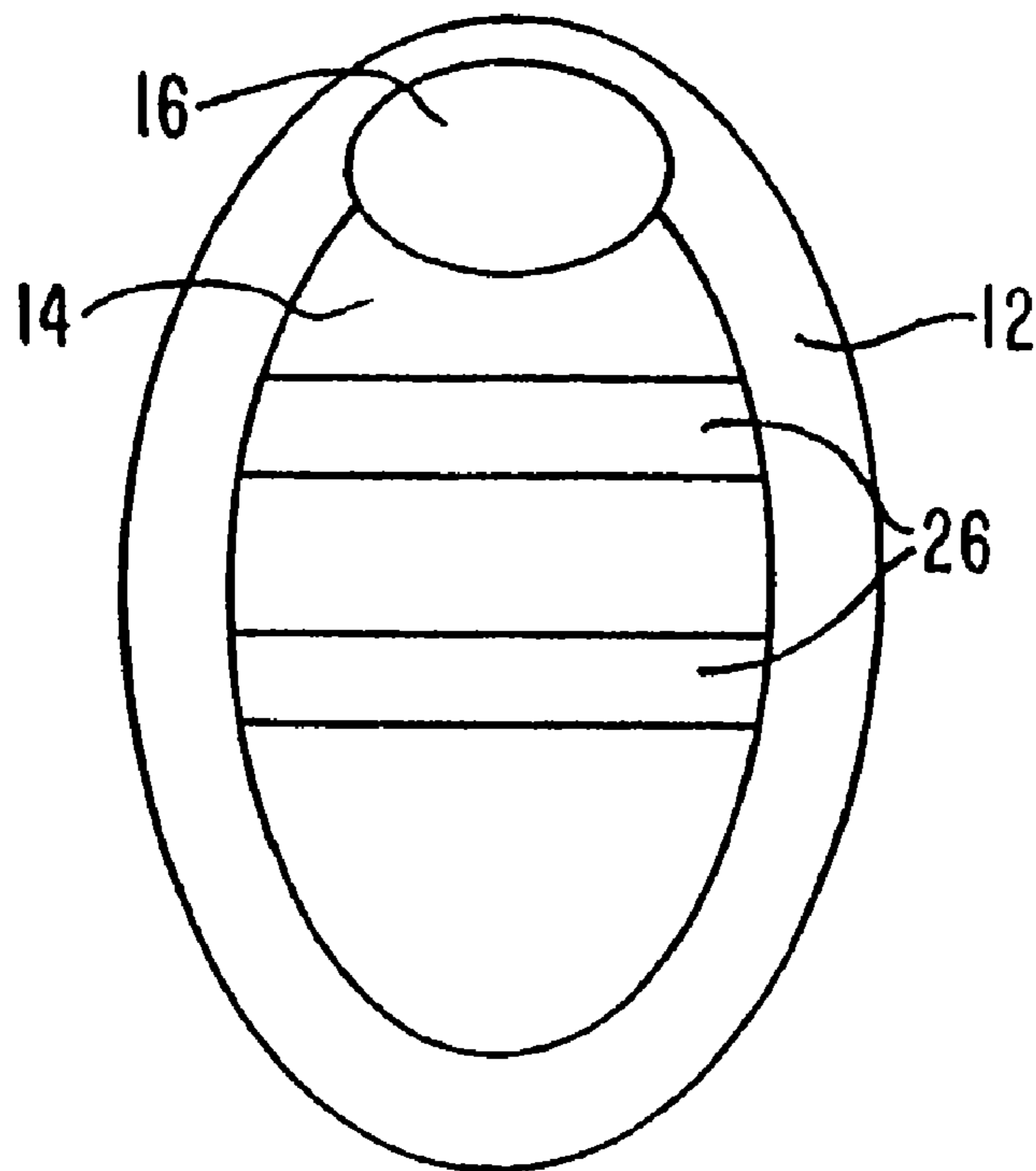

FIG. 5

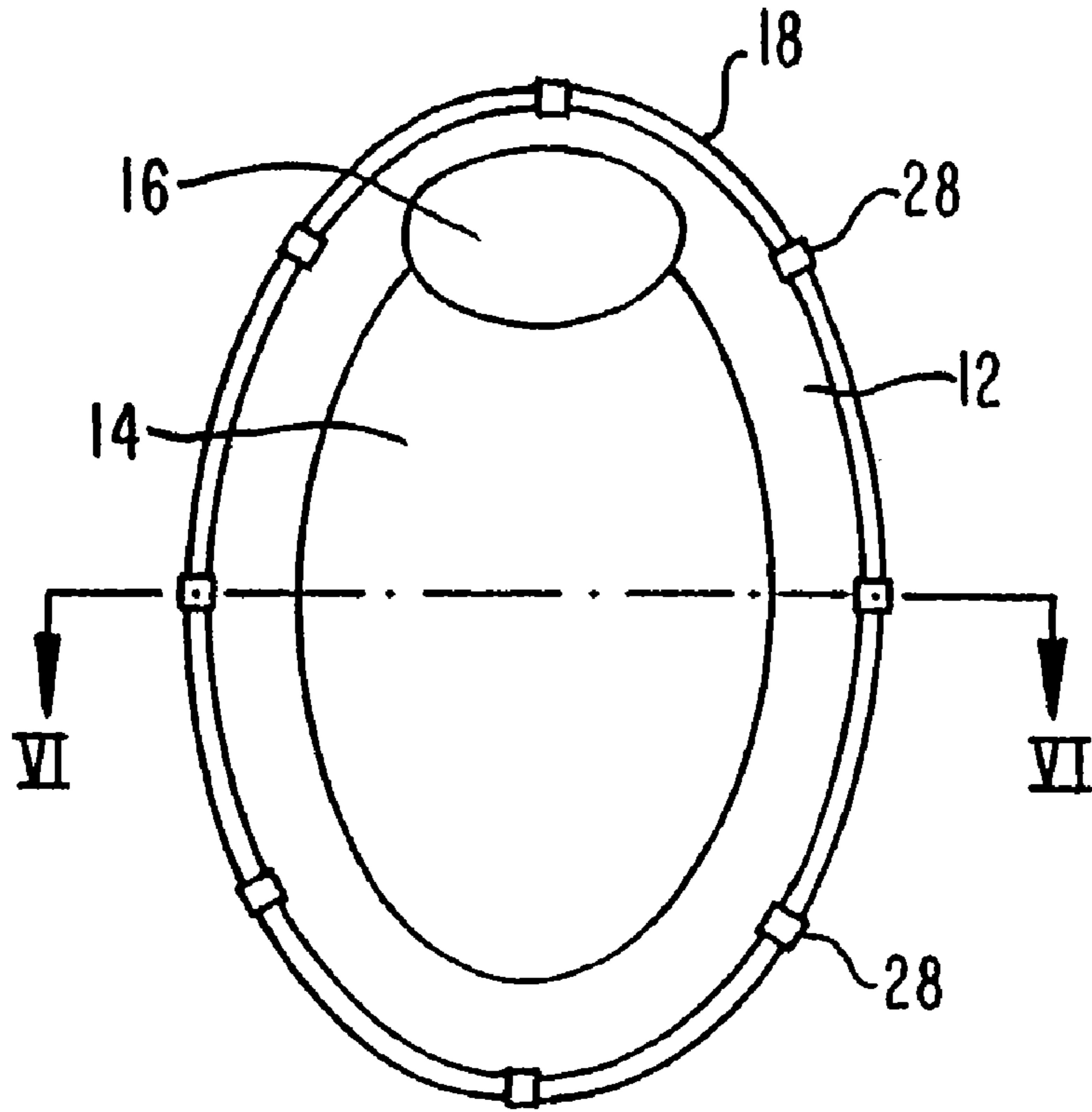

FIG. 6

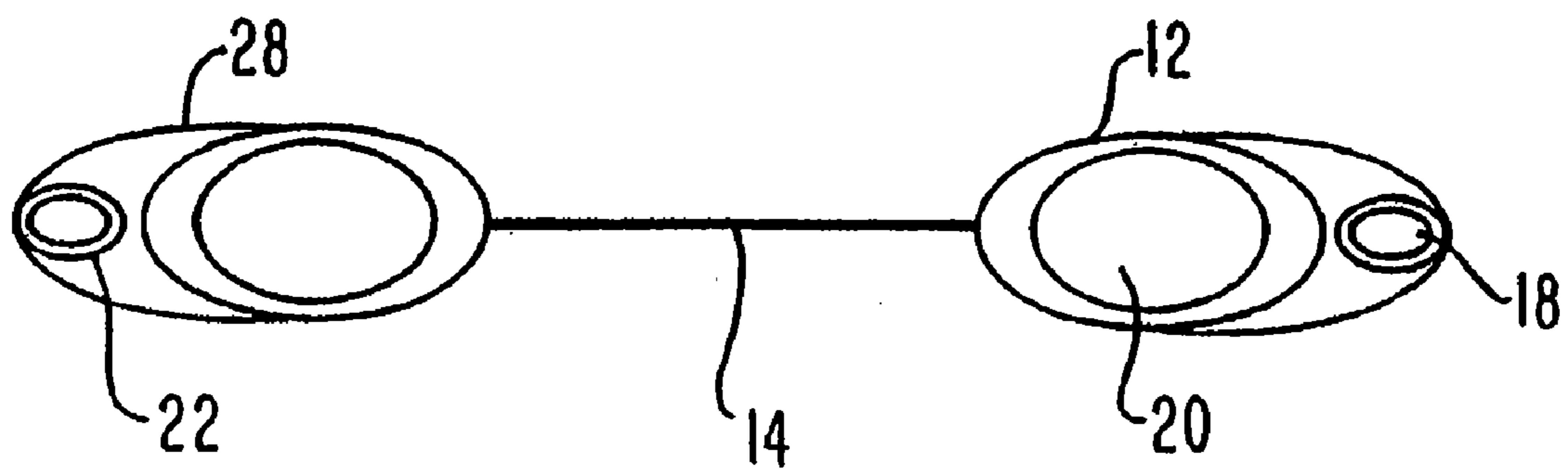

FIG. 7

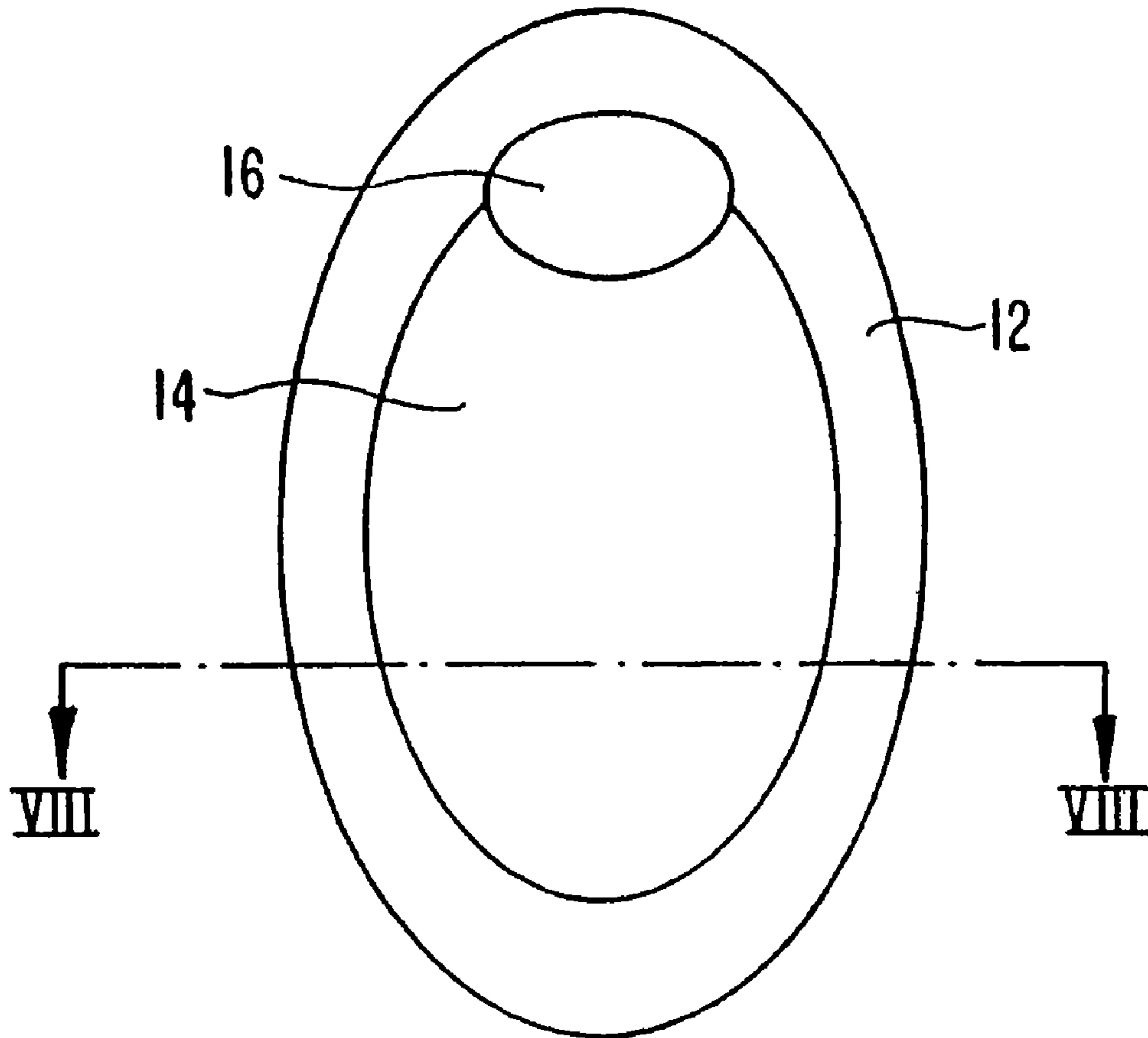

FIG. 8

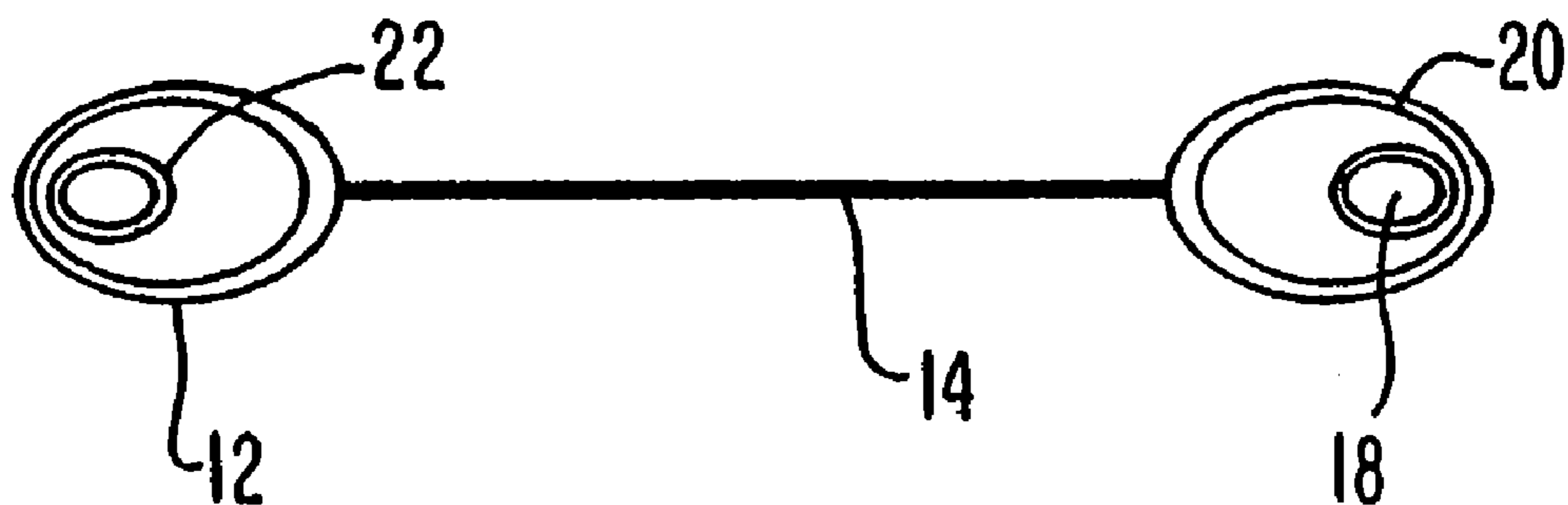
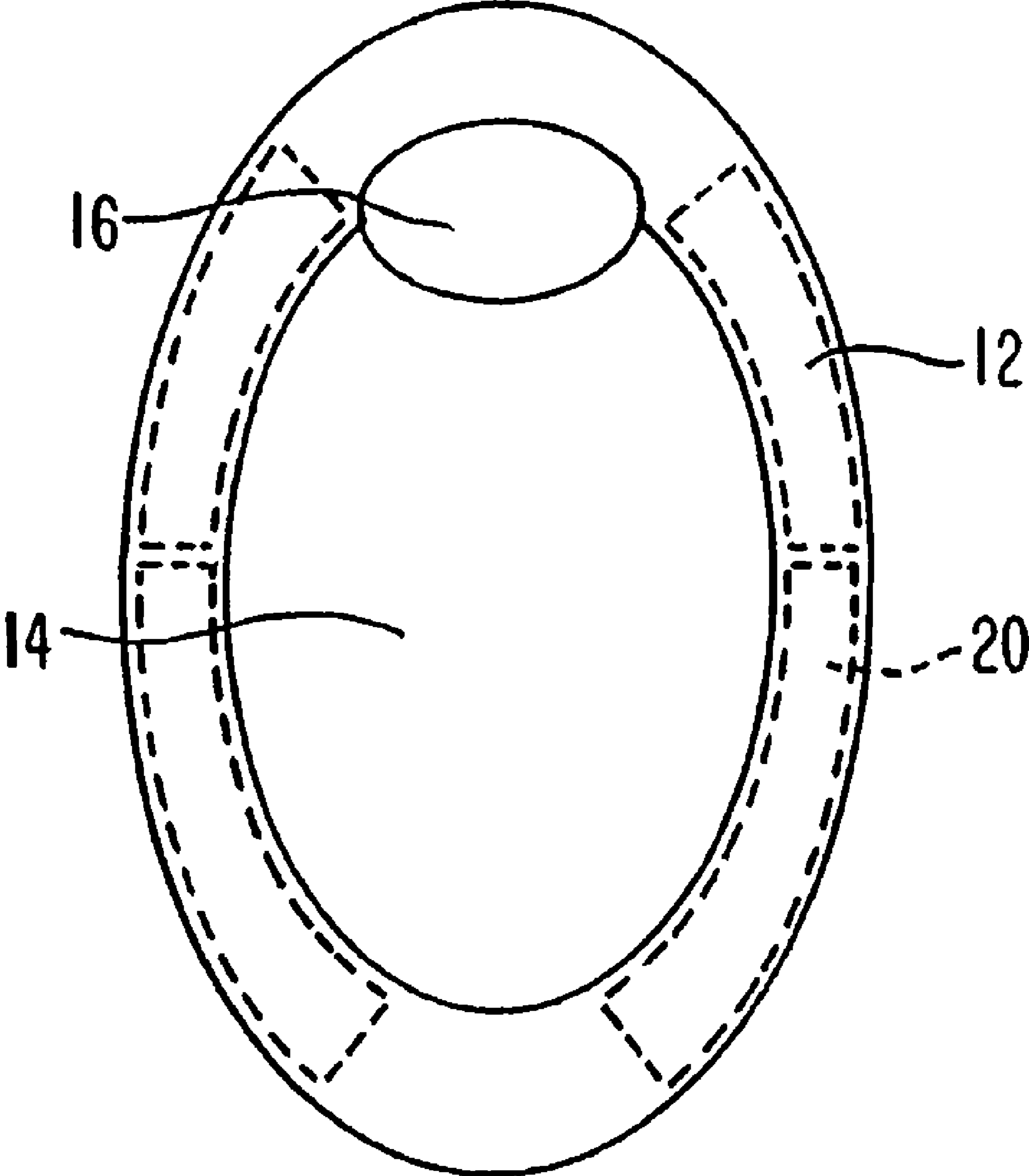

FIG. 9



COLLAPSIBLE FLOTATION DEVICE**CROSS REFERENCE TO RELATED APPLICATION**

This application is a continuation of U.S. application Ser. No. 11/143,703, filed Jun. 3, 2005, (now U.S. Pat. No. 7,134,930), which is a continuation of U.S. application Ser. No. 10/847,339, filed May 18, 2004, (now U.S. Pat. No. 7,147,528), which is a continuation of U.S. application Ser. No. 10/295,906, filed Nov. 18, 2002, (now U.S. Pat. No. 7,097,524), which is also a continuation of U.S. application Ser. No. 09/772,739, filed Jan. 30, 2001, (now U.S. Pat. No. 6,485,344), which claims priority from U.S. Provisional Application Ser. No. 60/238,988, filed Oct. 10, 2000; the disclosures of which are incorporated herein by reference.

BACKGROUND OF THE INVENTION**1. Field of the Invention**

The present invention relates to inflatable flotation devices. In particular, the present invention relates to inflatable flotation devices which are collapsible through use of a spring mechanism.

2. Description of the Related Art

Inflatable flotation devices are well known in the form of floats, rafts, lifeboats, life preservers and other like devices. Previously known devices generally maintain their shape through air pressure alone and generally collapse when deflated.

In one of many examples, U.S. Pat. No. 3,775,782 issued to Rice et al. describes an inflatable rescue raft. When deflated, the raft can be rolled into a compact size.

Also well known in the art are collapsible items which are collapsible through the use of a collapsible metal or plastic spring. U.S. Pat. No. 4,815,784 shows an automobile sun shade which uses these collapsible springs. The springs are also used in children's play structures (U.S. Pat. Nos. 5,618,246 and 5,560,385) and tent-like shade structures (U.S. Pat. Nos. 5,579,799 and 5,467,794).

The collapsible springs are typically retained or held within fabric sleeves provided along the edges of a piece of fabric or other panel. The collapsible springs may be provided as one continuous loop, or may be a strip or strips of material connected at the ends to form a continuous loop. These collapsible springs are usually formed of flexible coilable steel, although other materials such as plastics are also used. The collapsible springs are usually made of a material which is relatively strong and yet is flexible to a sufficient degree to allow it to be coiled. Thus, each collapsible spring is capable of assuming two configurations, a normal uncoiled or expanded configuration, and a coiled or collapsed configuration in which the spring is collapsed into a size which is much smaller than its open configuration. The springs may be retained within the respective fabric sleeves without being connected thereto. Alternatively, the sleeves may be mechanically fastened, stitched, fused, or glued to the springs to retain them in position.

SUMMARY OF THE DISCLOSURE

A device comprises a spring and a sleeve. The spring is configured to form a closed loop. The spring is moveable between a coiled configuration when the spring is collapsed and an uncoiled configuration when the spring is expanded. The spring defines a circumference while in the uncoiled configuration. The spring is disposed within the sleeve. The

sleeve includes an inflatable portion disposed about at least a portion of the circumference.

It is therefore an object of the present invention to provide a collapsible flotation device.

It is another object of the present invention to provide a collapsible flotation device which is easily collapsed and extended to full size through a mechanical means.

It is yet another object of the present invention to provide a collapsible flotation device which is easily collapsed and extended to full size through the use of a spring.

It is yet a further object of the present invention to provide a collapsible flotation device which requires minimal force to twist and fold into the collapsed configuration.

Finally, it is an object of the present invention to accomplish the foregoing objectives in a simple and cost effective manner.

DESCRIPTION OF THE DRAWINGS

FIG. 1 is a top view of the preferred embodiment of the present invention;

FIG. 2 is a cross sectional view of the preferred embodiment of the present invention taken along line II-II of FIG. 1;

FIG. 3 is a view of a joining method as used in one embodiment of the present invention;

FIG. 4 is a top view of an alternate embodiment of the present invention;

FIG. 5 is a top view of another alternate embodiment of the present invention;

FIG. 6 is a cross section view of the alternate embodiment of the present invention across line VI-VI of FIG. 5; and

FIG. 7 is a top view of an alternative embodiment of the present invention;

FIG. 8 is a cross sectional view of the embodiment of the present invention, taken along line VIII-VIII of FIG. 7; and

FIG. 9 is a plan view of another embodiment of the present invention.

DETAILED DESCRIPTION OF THE PREFERRED EMBODIMENTS

The following detailed description is of the best presently contemplated modes of carrying out the invention. This description is not to be taken in a limiting sense, but is made merely for the purpose of illustrating general principles of embodiments of the invention.

The present invention provides a collapsible flotation device. The device includes a coilable metal or plastic spring. The coilable spring can be made from other materials, however, it is important that the coilable spring be made from a material that is strong and flexible. The spring must be coilable such that it folds on top of itself to become more compact. In its uncoiled state, the coilable spring can be round or oval or any shape satisfactory for use as a flotation device. Because it is to be used in water, the coilable spring is preferably either manufactured from a waterproof material or coated to protect any material which is not waterproof. The coilable spring can be a single continuous element or can include a joining means, such as a sleeve, for joining the ends of one or more spring elements together. The coilable spring can be of any appropriate shape and dimension. The coilable spring also has memory such that is biased to return to its uncoiled configuration when not held in the coiled configuration.

Stretched across the coilable spring is a flexible panel of material. The flexible panel can be one continuous piece or

3

can be made up of several different types of material. In a preferred embodiment, the center portion of the flexible panel is mesh to allow water to flow through while the perimeter edges are nylon or polyester. At the edges of the flotation device, the material is a double thickness, forming a pocket around the perimeter of the flotation device. In this pocket are one or more inflatable chambers. One inflatable chamber may surround the entire perimeter of the flotation device or it may be divided into two or more inflatable chambers with each inflatable chamber having a means for inflating and deflating the inflatable chamber. In a preferred embodiment, one inflatable chamber is specifically designed to accommodate the user's head. In this embodiment, the pocket formed by the material is wider along a small portion of the perimeter of the flotation device to allow for a wider inflatable chamber. This will prevent the user's head from sinking below the rest of the user's body. The size of the inflatable chamber can vary significantly and need only be as wide as necessary to support the user's body weight. A preferred embodiment includes an inflatable chamber which is 3 inches in diameter when inflated. The inflatable chamber can be made from any appropriate float material but is preferably resistant to punctures. The coilable spring may also be located within the perimeter pocket. If one inflatable chamber is selected, the coilable spring can be placed inside or outside the inflatable chamber. If multiple inflatable chambers are used, the coilable spring will be outside the inflatable chambers. Alternatively, the coilable spring may be located outside the perimeter pocket along the outer edge of the flotation device. The coilable spring may be attached to the flexible panel through mechanical means such as fastening, stitching, fusing, or gluing.

A preferred embodiment of the flotation device is shown in FIGS. 1 and 2 in its expanded configuration. The perimeter pocket 12 portion of the flexible panel is nylon while the central portion 14 of the flexible panel is made from a mesh material. The pillow 16 is part of the perimeter pocket 12 as it includes a double layer of fabric to accept an inflatable chamber 20 between the layers of fabric. In this particular embodiment, there are two inflatable chambers 20 in the perimeter pocket of the flotation device and one in the pillow 16, each of which includes a means for inflating the inflatable chamber 20. The inflation means is a valve on the underside of the flotation device. The inflatable chambers 20 in the perimeter pocket of the flotation device expand to approximately a 3-inch diameter when inflated. The coilable spring 18 is made from flexible, collapsible steel and is coated with a layer of PVC 22 to protect the coilable spring 18 from corroding and rusting due to contact with water during normal use of the flotation device. The coilable spring 18 also has memory such that will open to its uncoiled configuration when not held in the coiled configuration. The coilable spring 18 can be a single unitary element or can include sleeves 24 for joining the ends of one or more strips as shown in FIG. 3 in which the ends of the coilable spring 18 within the sleeve 24 are shown in dashed lines for clarification.

Alternatively or in addition to the perimeter inflatable chambers, the device can include inflatable chambers 26 which cross the panel as shown in FIG. 4. FIGS. 5 and 6 show a further alternate embodiment of the present invention in which the coilable spring 18 is attached to the external perimeter of the pocket portion 12 of the flexible panel through the use of a mechanical means. In this particular embodiment, several loops 28 are used to attach the coilable spring 18 to the pocket portion 12 of the flexible panel.

4

While the description above refers to particular embodiments of the present invention, it will be understood that many modifications may be made without departing from the spirit thereof. The accompanying claims are intended to cover such modifications as would fall within the true scope and spirit of the present invention.

What is claimed is:

1. An apparatus, comprising:

a spring forming a closed loop and being moveable between a coiled configuration when the spring is collapsed and an uncoiled configuration when the spring is expanded;

a first flexible material having an outer perimeter;

a second flexible material different from the first flexible material, the second flexible material defining an interior volume, an inner perimeter and an outer perimeter, the inner perimeter of the second flexible material being coupled to the outer perimeter of the first flexible material, the second flexible material being coupled to the spring; and

an inflatable chamber valve accessible from outside of the second flexible material, the inflatable chamber valve configured to communicate air to at least a portion of the interior volume of the second flexible material.

2. The apparatus of claim 1, wherein:

the second flexible material defines a substantially toroidal shape when an inflatable chamber associated with the inflatable chamber valve is inflated and the spring is in the uncoiled configuration.

3. The apparatus of claim 1, further comprising:

a coating disposed on an outer surface of the spring.

4. The apparatus of claim 1, further comprising:

a plurality of fastening members coupling the spring to the second flexible material.

5. The apparatus of claim 1, further comprising:

a plurality of fastening members coupling the spring to the second flexible material, the plurality of fastening members including at least a first loop and a second loop.

6. The apparatus of claim 1, wherein the inflatable chamber valve is a first inflatable chamber valve, the apparatus further comprising:

a second inflatable chamber valve accessible from outside of the second flexible material, the second inflatable chamber valve configured to communicate air to a portion of the interior volume of the second flexible material different from the portion of interior volume associated with the first inflatable chamber valve.

7. The apparatus of claim 1, further comprising:

an inflatable bladder coupled to the first flexible material, the inflatable bladder defining a pillow portion disposed at least partially within the outer perimeter of the first flexible material.

8. An apparatus, comprising:

a panel having a central portion formed with a first material and a perimeter portion formed with a second material different than the first material, the perimeter portion of the panel defining an interior volume within which an inflatable chamber is defined; and

a spring coupled to the perimeter portion of the panel and configured to form a closed loop, the spring being moveable between a coiled configuration when the spring is collapsed and an uncoiled configuration when the spring is expanded,

5

the apparatus configured to buoyantly support a body weight of a user disposed on the panel when the inflatable chamber is inflated and the spring is in the uncoiled configuration.

9. The apparatus of claim 8, further comprising: 5

an inflatable bladder, the inflatable bladder being disposed within the interior volume of the perimeter portion of the panel and corresponding to the inflatable chamber.

10. The apparatus of claim 8, wherein the spring is disposed within the interior volume of the perimeter portion 10 of the panel.

11. The apparatus of claim 8, further comprising:

a plurality of fastening members coupling the spring to the perimeter portion of the panel.

12. The apparatus of claim 8, wherein the first material is 15 mesh.

13. The apparatus of claim 8, further comprising:

an inflatable bladder coupled to the central portion of the panel, the inflatable bladder defining a pillow portion disposed at least partially within an interior area within 20 the closed loop.

14. An apparatus, comprising:

a spring forming a closed loop and being moveable between a coiled configuration when the spring is collapsed and an uncoiled configuration when the 25 spring is expanded;

a first flexible material having an outer perimeter; and
a second flexible material defining an interior volume and an inner perimeter, the inner perimeter of the second flexible material being coupled to the outer perimeter of 30 the first flexible material, the second flexible material

6

being coupled to the spring, the second flexible material defining a substantially toroidal shape when an inflatable chamber within at least a portion of the interior volume of the second flexible material is inflated and the spring is in the uncoiled configuration.

15. The apparatus of claim 14, further comprising an inflatable chamber valve accessible from outside of the second flexible material, the inflatable chamber valve configured to communicate air to the inflatable chamber.

16. The apparatus of claim 14, wherein the spring is disposed within the interior portion of the second flexible material.

17. The apparatus of claim 14, wherein the first flexible material includes a mesh central portion.

18. The apparatus of claim 14, further comprising: an inflatable bladder disposed within the interior volume of the second flexible material and defining the inflatable chamber.

19. The apparatus of claim 14, further comprising: an inflatable bladder that extends from a first point to a second point across a central portion of the first flexible material.

20. The apparatus of claim 14, further comprising: a first inflatable bladder disposed at least partially within the interior volume of the second flexible material; and a second inflatable bladder disposed at least partially within the interior volume of the second flexible material.

* * * * *