

US007306591B2

(12) **United States Patent**
Thomas et al.

(10) **Patent No.:** **US 7,306,591 B2**
(45) **Date of Patent:** **Dec. 11, 2007**

(54) **APPARATUS AND METHODS FOR
TREATING FEMALE URINARY
INCONTINENCE**

(75) Inventors: **Simon W. H. Thomas**, Danville, CA
(US); **Peter S. Edelstein**, Menlo Park,
CA (US); **John T. To**, Newark, CA
(US); **Benjamin T. Nordell**, San Mateo,
CA (US)

(73) Assignee: **Novasys Medical, Inc.**, Newark, CA
(US)

(*) Notice: Subject to any disclaimer, the term of this
patent is extended or adjusted under 35
U.S.C. 154(b) by 536 days.

5,588,960 A	12/1996	Edwards et al.	
5,607,422 A	3/1997	Smeets et al.	
5,630,812 A *	5/1997	Ellman et al. 606/41
5,868,708 A	2/1999	Hart et al.	
5,882,346 A	3/1999	Pomeranz et al.	
5,957,920 A	9/1999	Baker	
5,964,755 A	10/1999	Edwards	
6,015,407 A	1/2000	Rieb et al.	
6,035,238 A	3/2000	Ingle et al.	
6,056,744 A *	5/2000	Edwards 606/41
6,077,257 A	6/2000	Edwards et al.	
6,081,749 A	6/2000	Ingle et al.	
6,091,995 A	7/2000	Ingle et al.	
6,156,032 A	12/2000	Lennox et al.	

(21) Appl. No.: **10/273,900**

(22) Filed: **Oct. 16, 2002**

(65) **Prior Publication Data**
US 2003/0181897 A1 Sep. 25, 2003

Related U.S. Application Data

(63) Continuation-in-part of application No. 10/207,689,
filed on Jul. 25, 2002, which is a continuation-in-part
of application No. 09/678,500, filed on Oct. 2, 2000,
now Pat. No. 6,470,219.

(51) **Int. Cl.**
A61B 18/18 (2006.01)

(52) **U.S. Cl.** **606/27**

(58) **Field of Classification Search** **606/27-52,**
606/41; 607/101

See application file for complete search history.

(56) **References Cited**

U.S. PATENT DOCUMENTS

5,366,490 A	11/1994	Edwards et al.	
5,454,782 A *	10/1995	Perkins 604/20
5,458,596 A	10/1995	Lax et al.	
5,569,241 A	10/1996	Edwards	

(Continued)

Primary Examiner—Michael Peffley
Assistant Examiner—Pete Vrettakos

(74) *Attorney, Agent, or Firm*—Jones Day; Nicola A. Pisano

(57) **ABSTRACT**

Apparatus and methods are provided for treating female urinary incontinence by applying a form of energy to tissue in the vicinity of the urethra and/or bladder outlet to change tissue compliance without substantially narrowing the urethral and/or bladder outlet lumen. The apparatus comprises an elongated shaft having a means for treating urethral tissue and an expandable member deployable distal of the means for treating. The expandable member is configured to be anchored against the bladder outlet to dispose the means for treating at a desired treatment site in the urethra using only tactile feedback. The means for treating may include a needleless RF electrode, an ultrasound transducer, or a cryogenic probe configured to be advanced through a hollow needle, each of which are designed to reduce or eliminate symptoms associated with urinary incontinence.

12 Claims, 12 Drawing Sheets

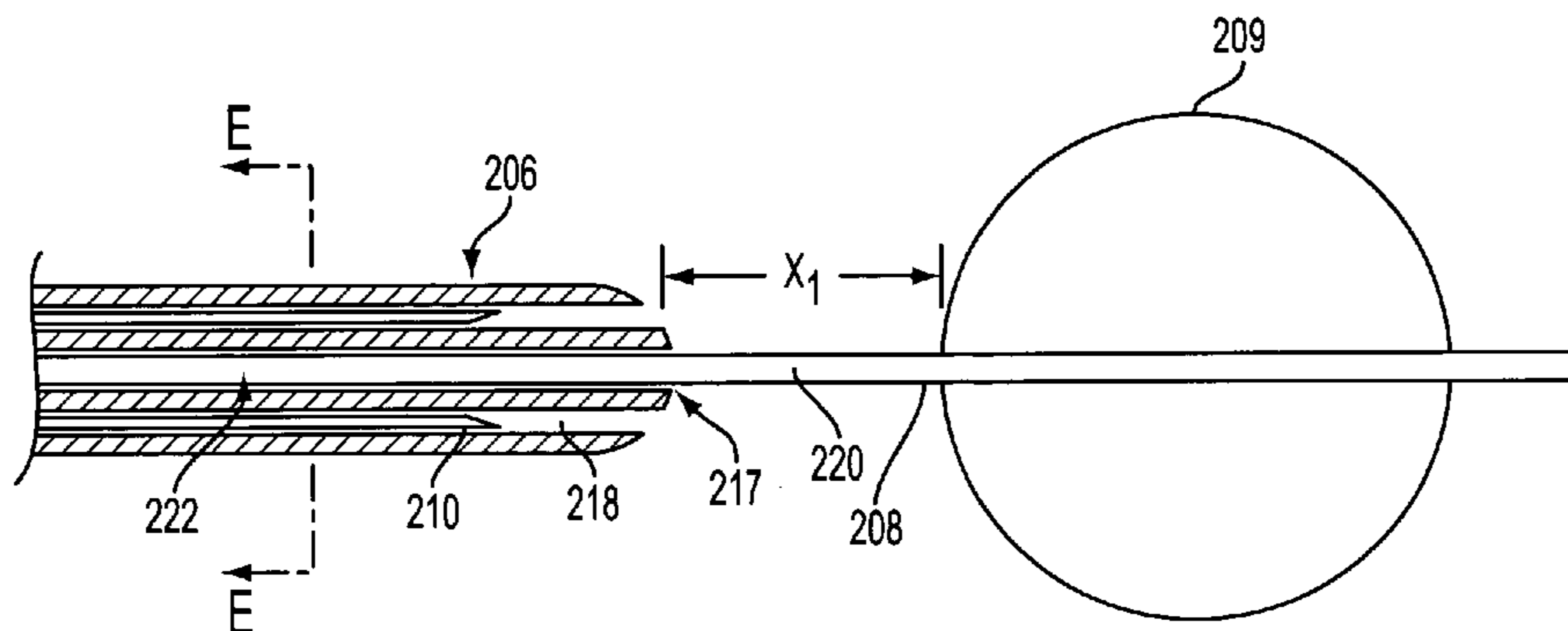

US 7,306,591 B2

Page 2

U.S. PATENT DOCUMENTS

6,156,060	A	12/2000	Roy et al.	6,463,331	B1 *	10/2002	Edwards	607/101
6,216,704	B1	4/2001	Ingle et al.	6,470,219	B1 *	10/2002	Edwards et al.	607/101
6,241,753	B1	6/2001	Knowlton	6,480,746	B1	11/2002	Ingle et al.		
6,254,598	B1	7/2001	Edwards et al.	6,743,226	B2 *	6/2004	Cosman et al.	606/41
6,283,987	B1	9/2001	Laird et al.						

* cited by examiner

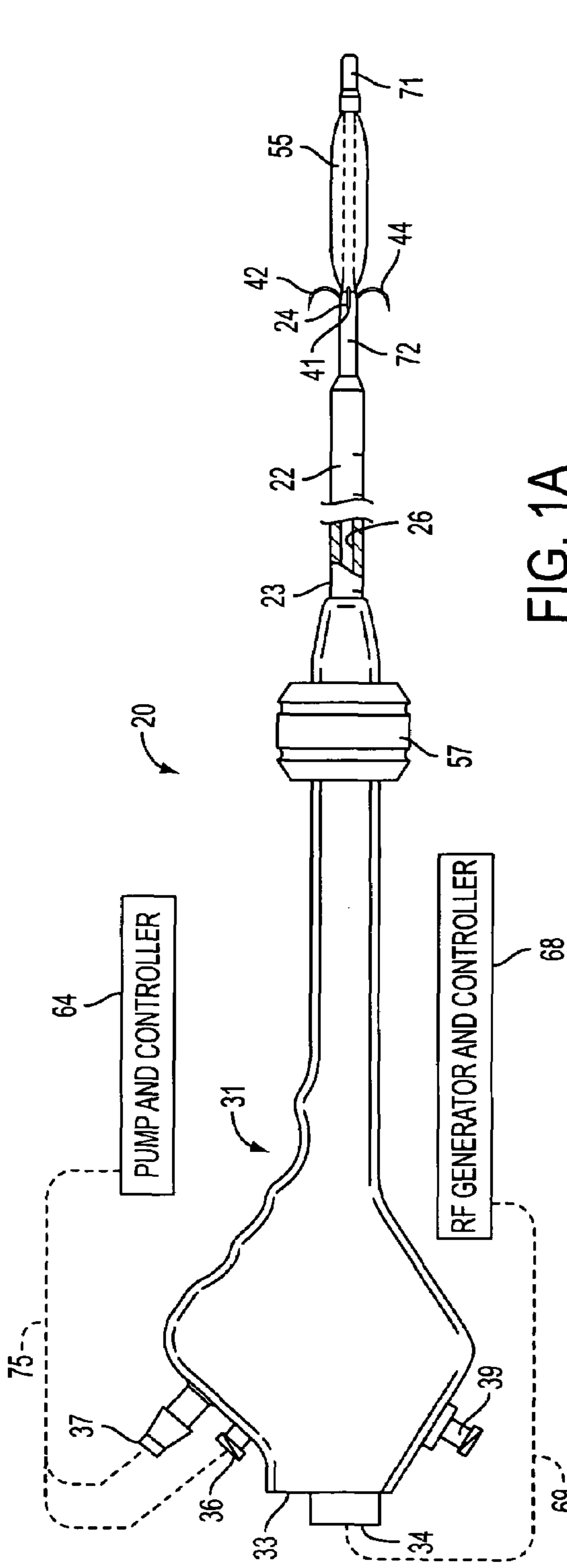

FIG. 1A

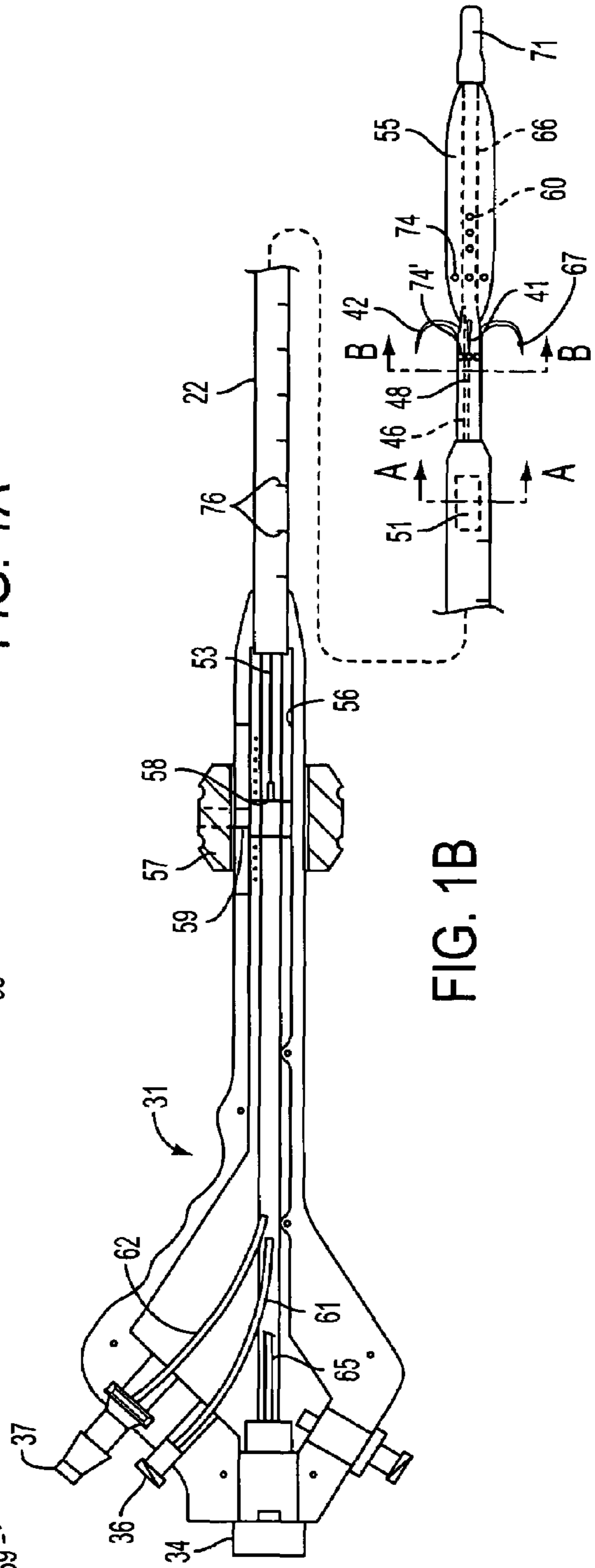

FIG. 1B

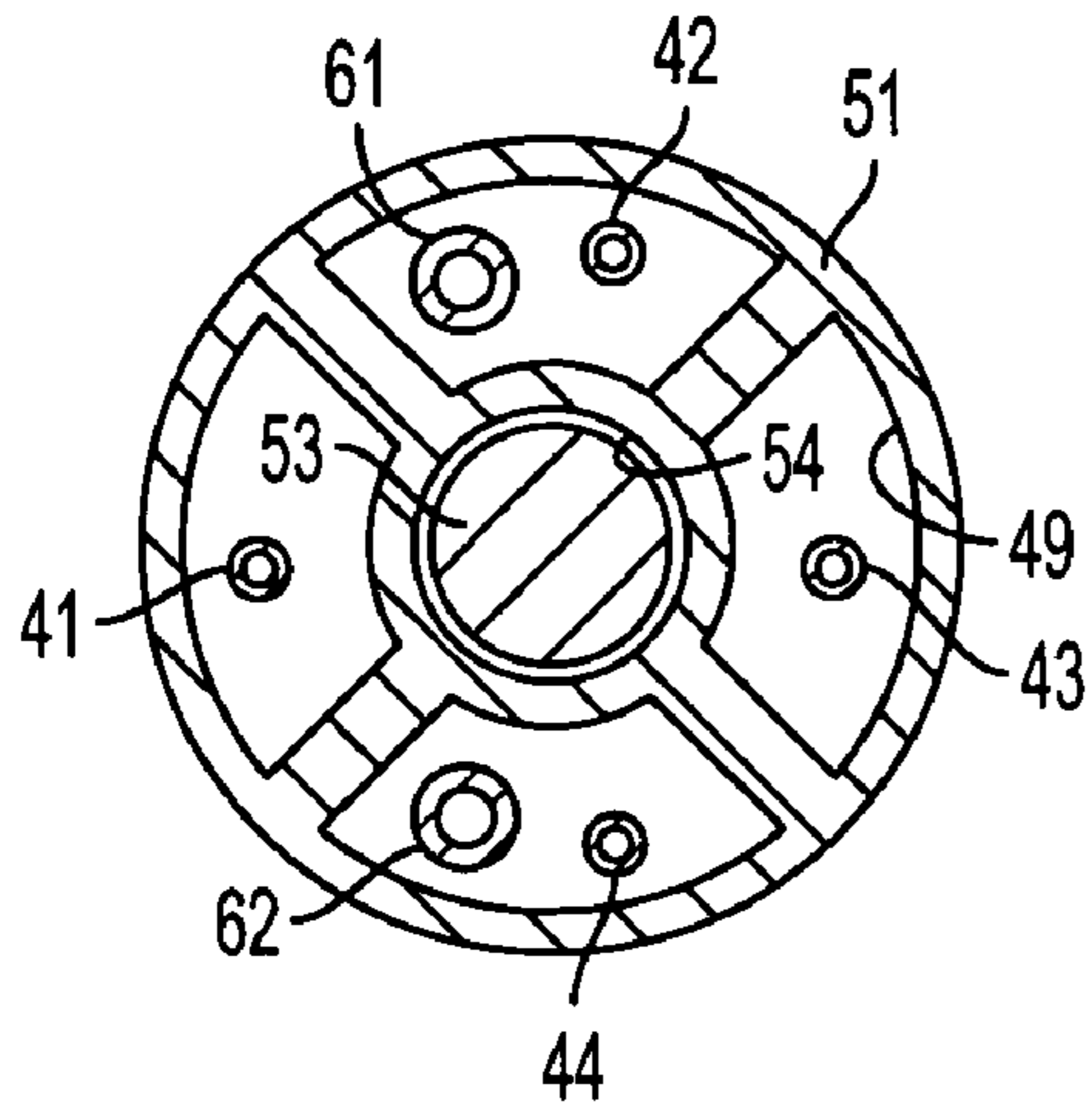

FIG. 1C

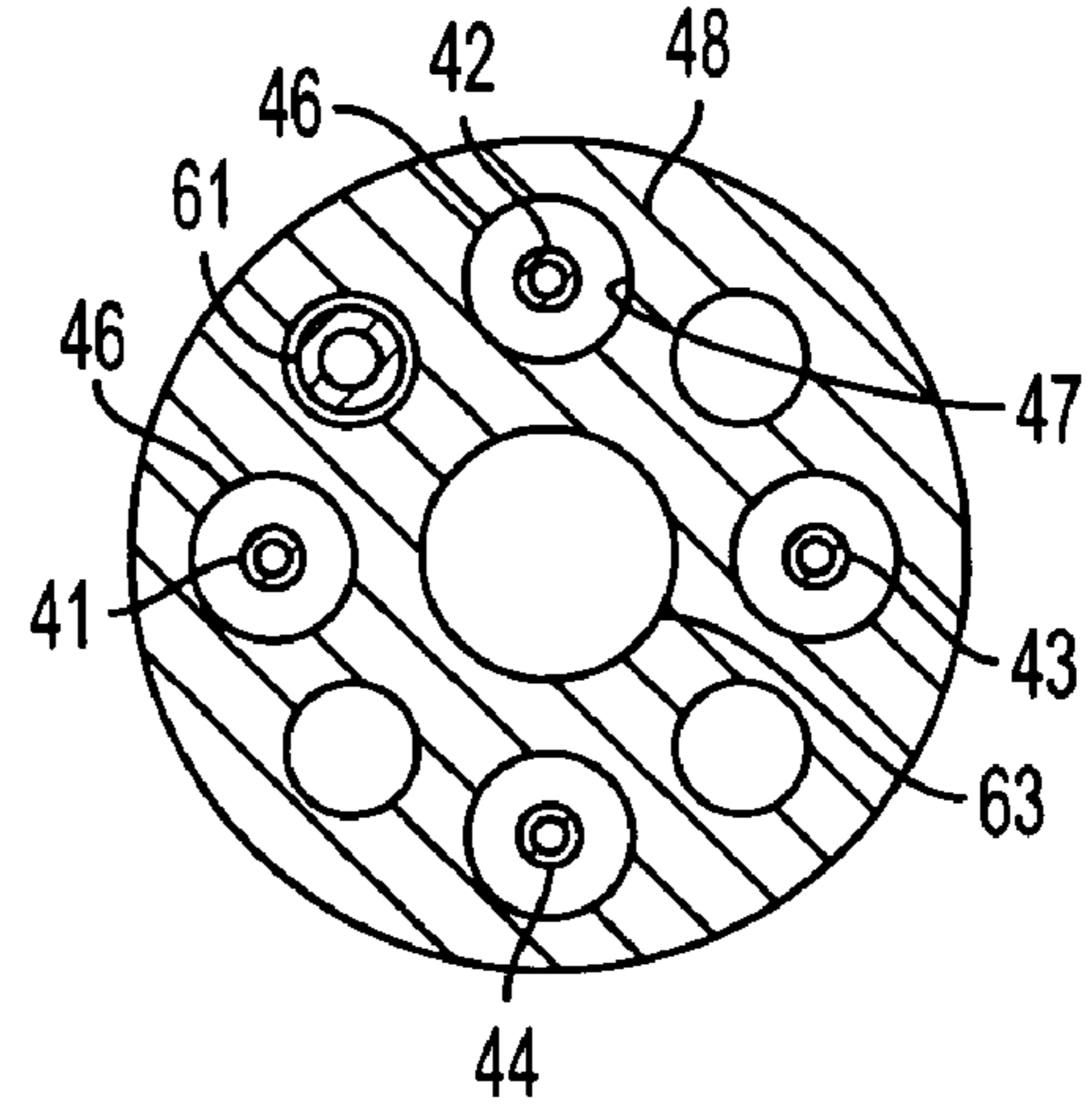

FIG. 1D

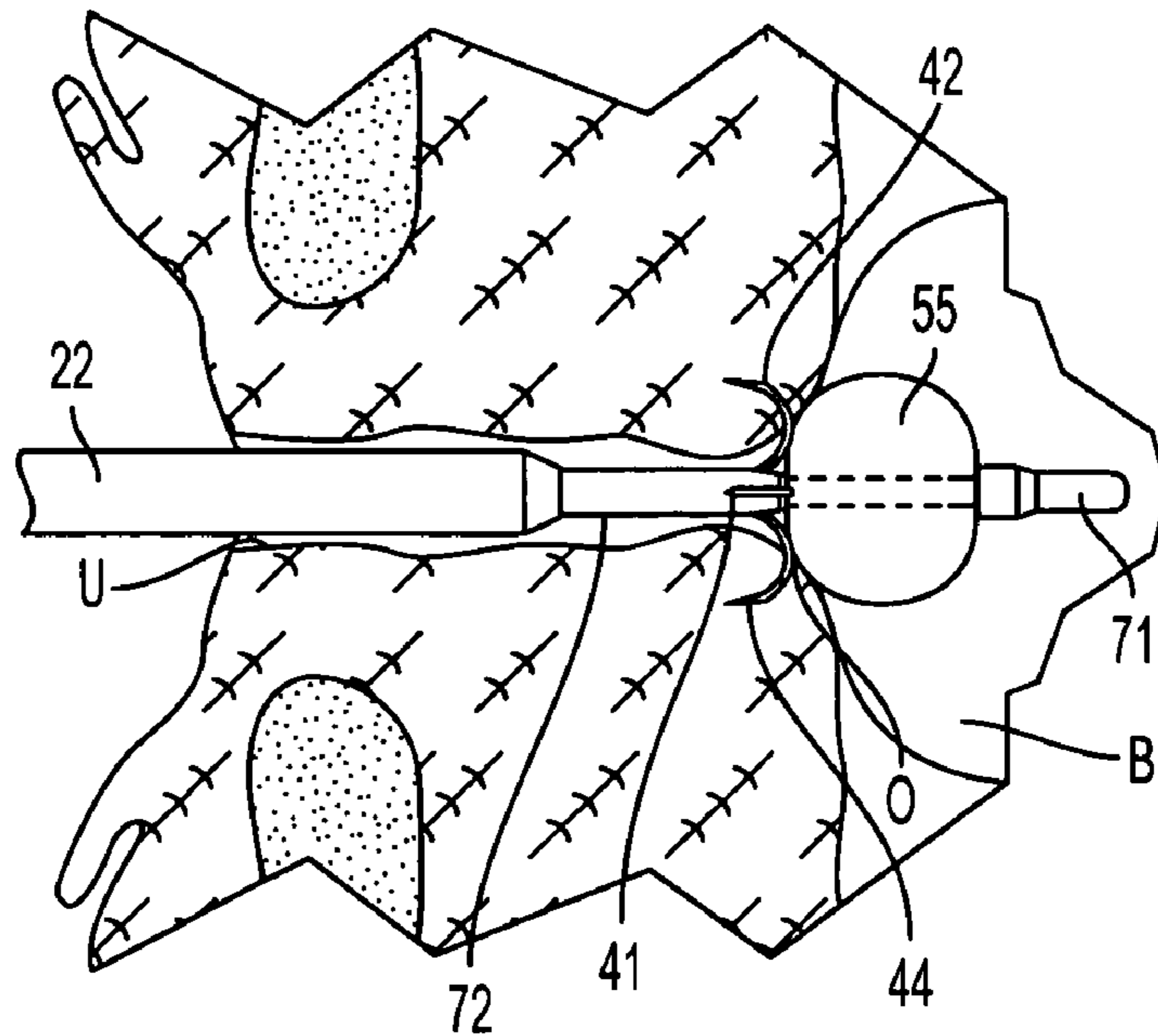

FIG. 1E

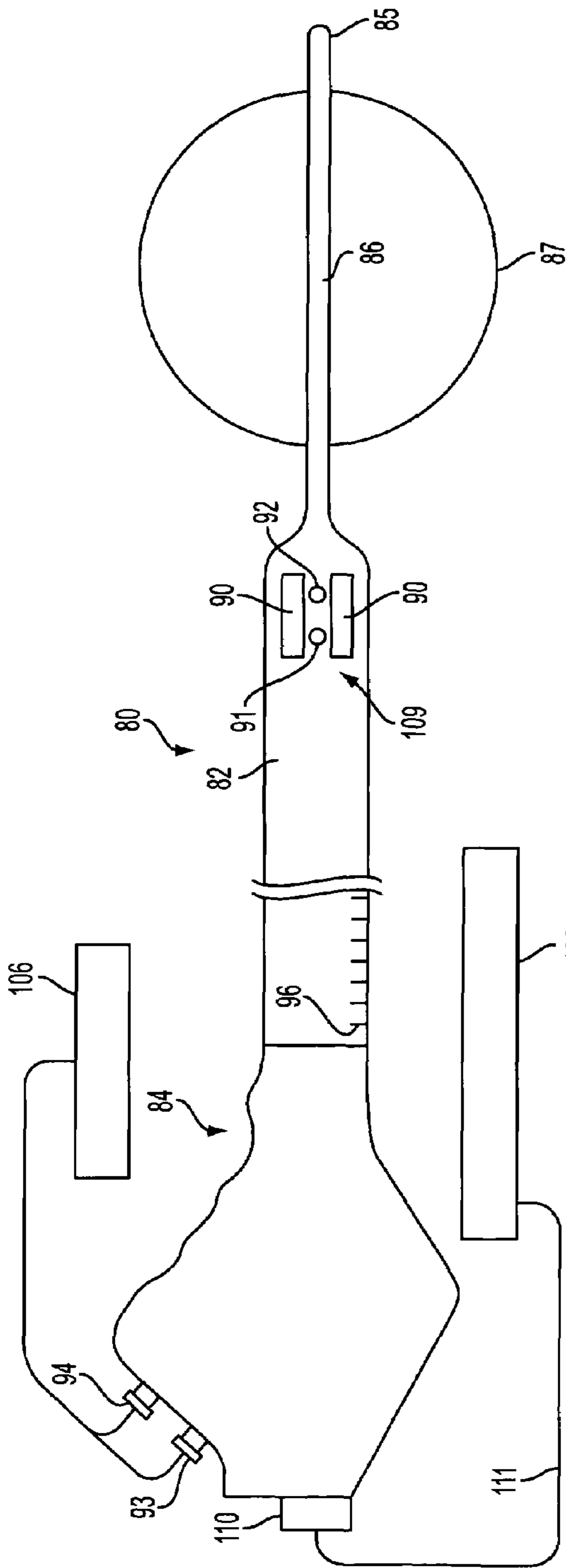

FIG. 2A

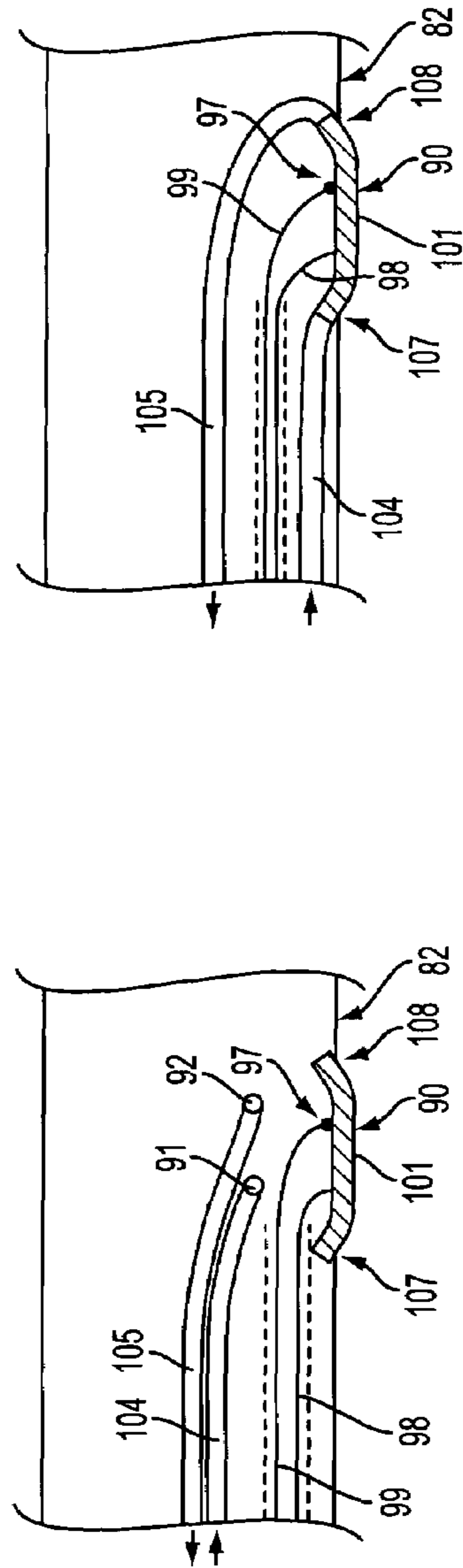

FIG. 2B

FIG. 2C

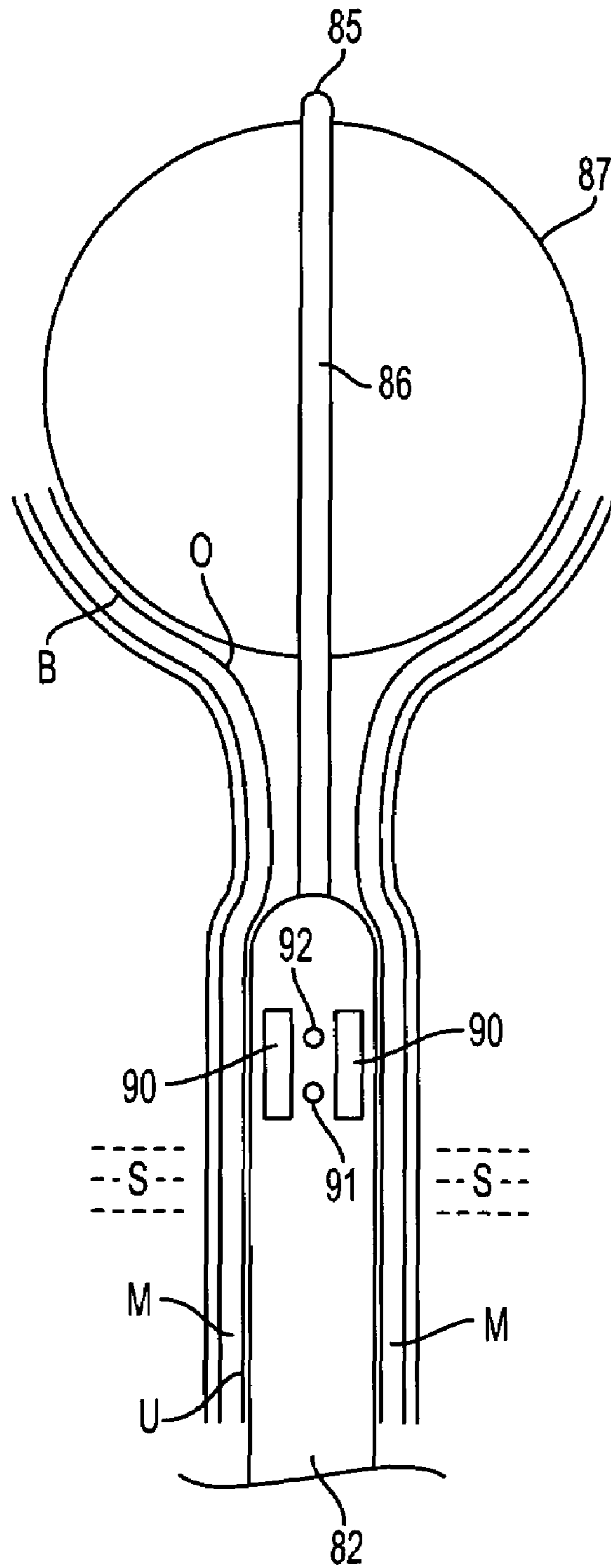

FIG. 3

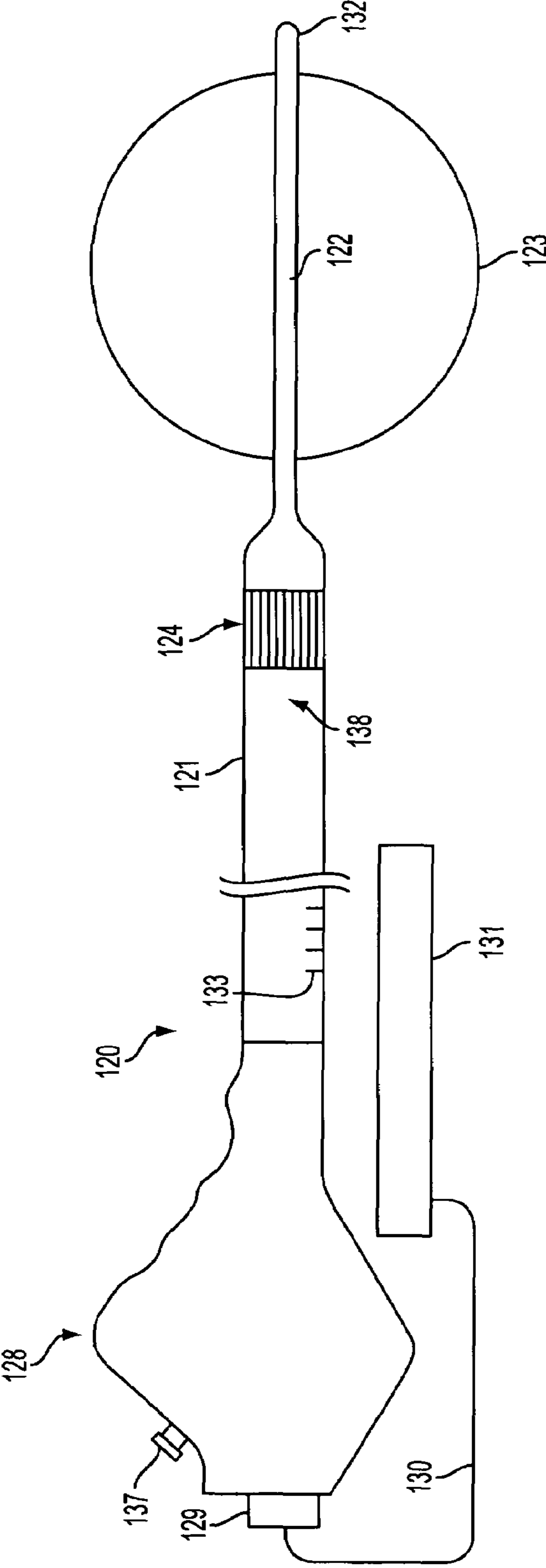

FIG. 4

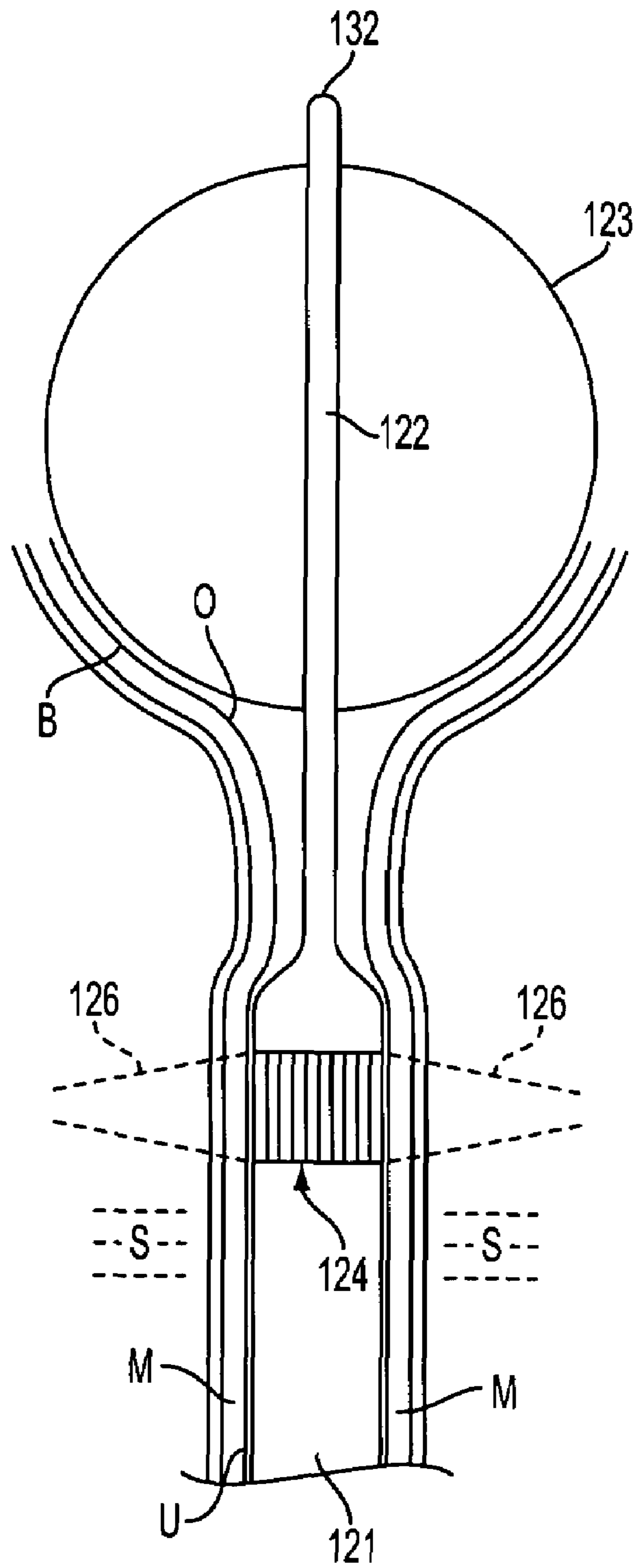

FIG. 5

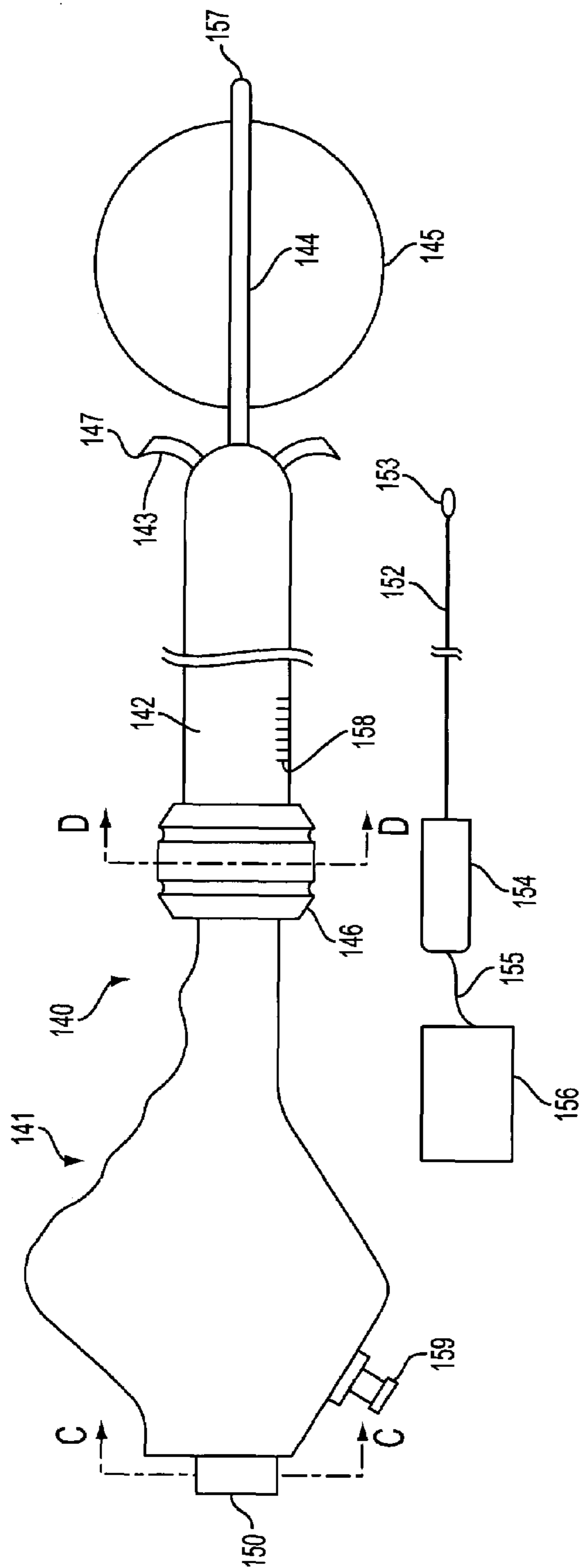

FIG. 6A

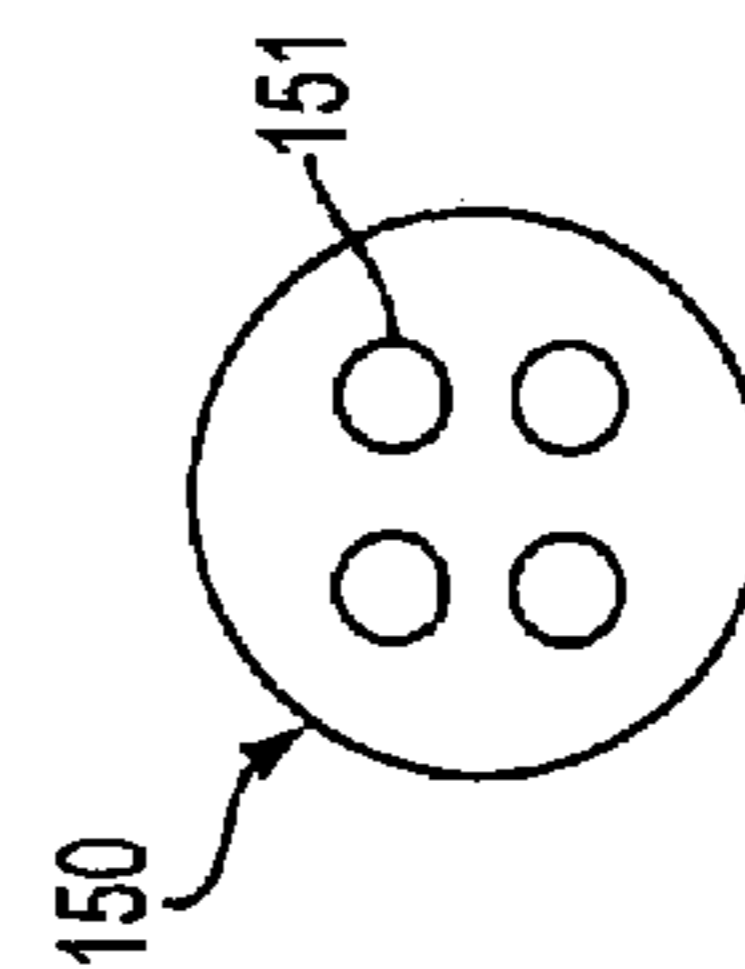

FIG. 6B

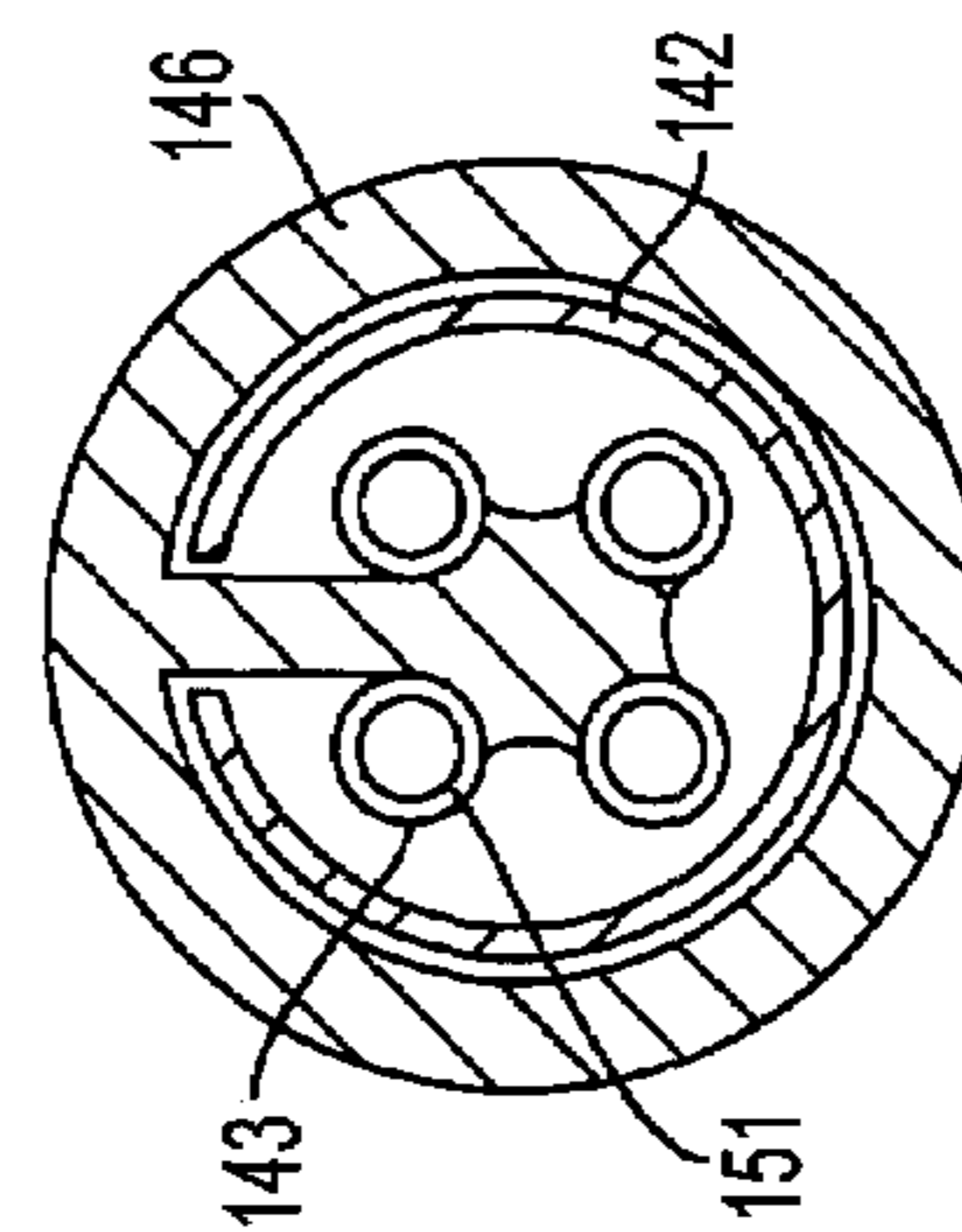

FIG. 6C

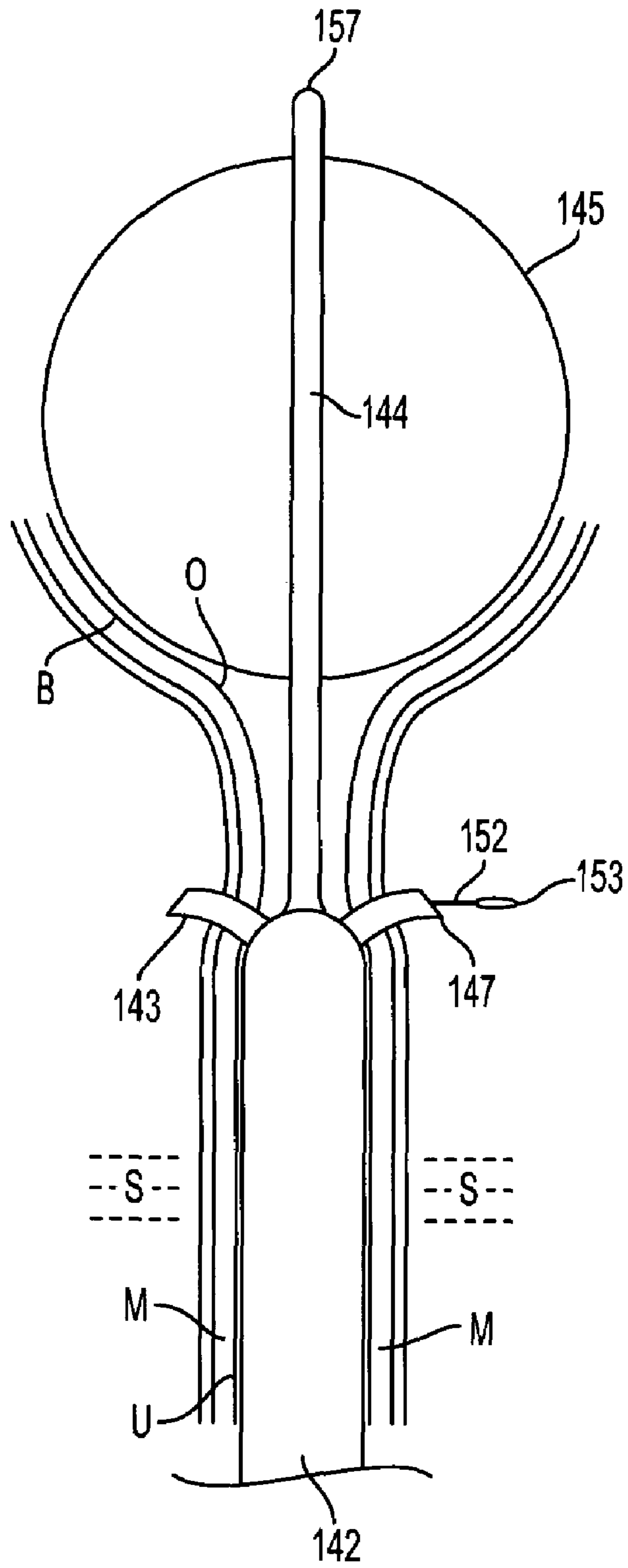

FIG. 7

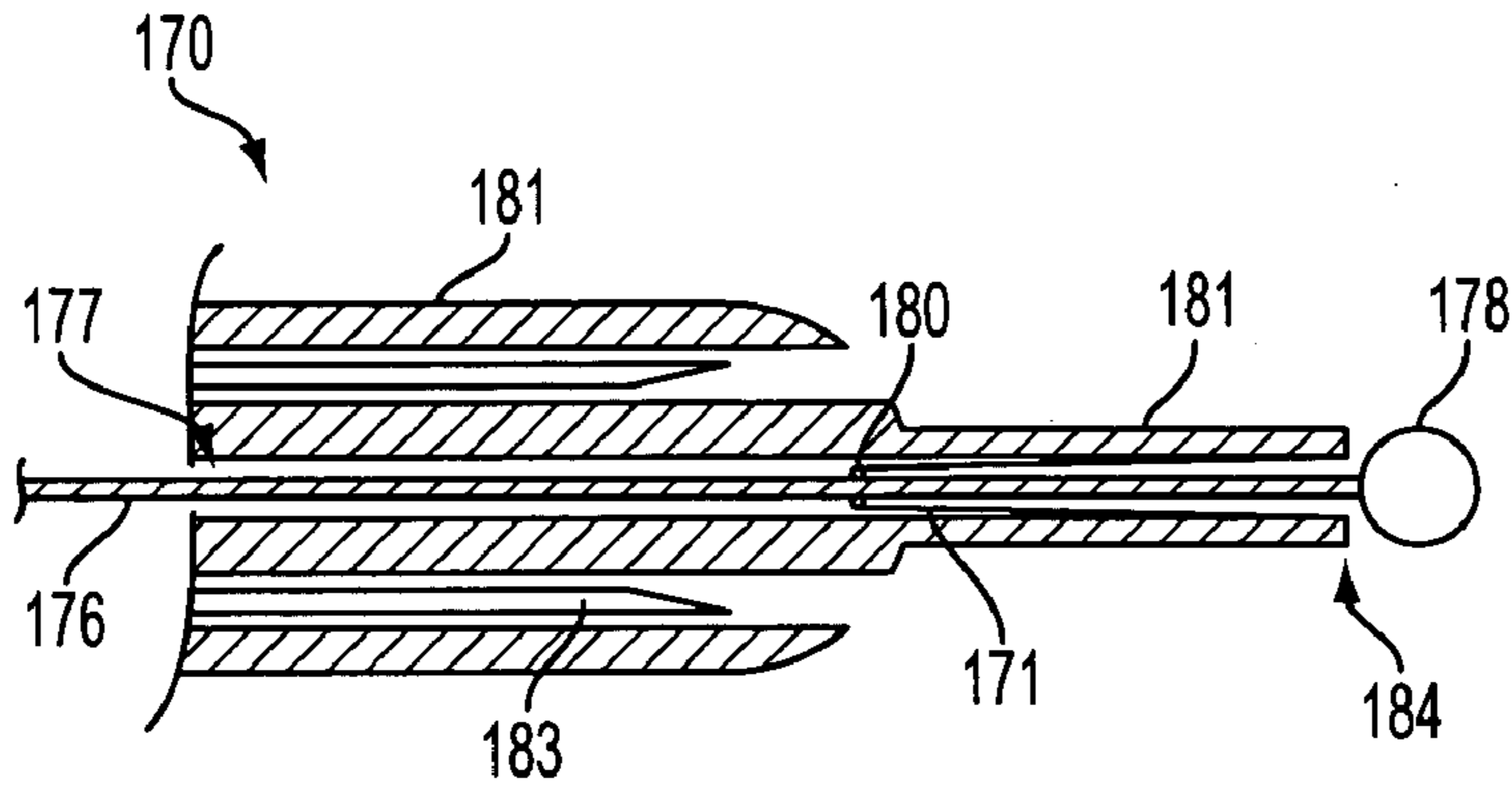

FIG. 8A

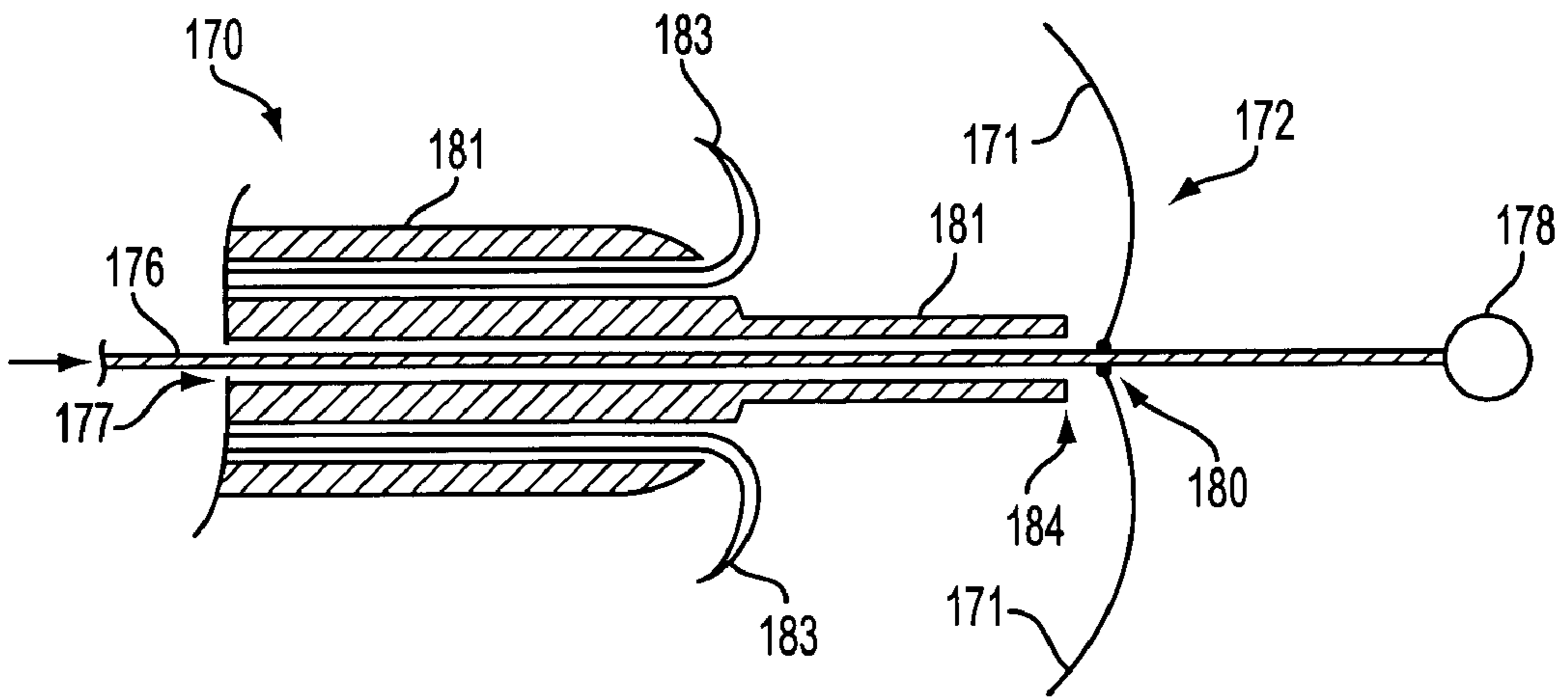

FIG. 8B

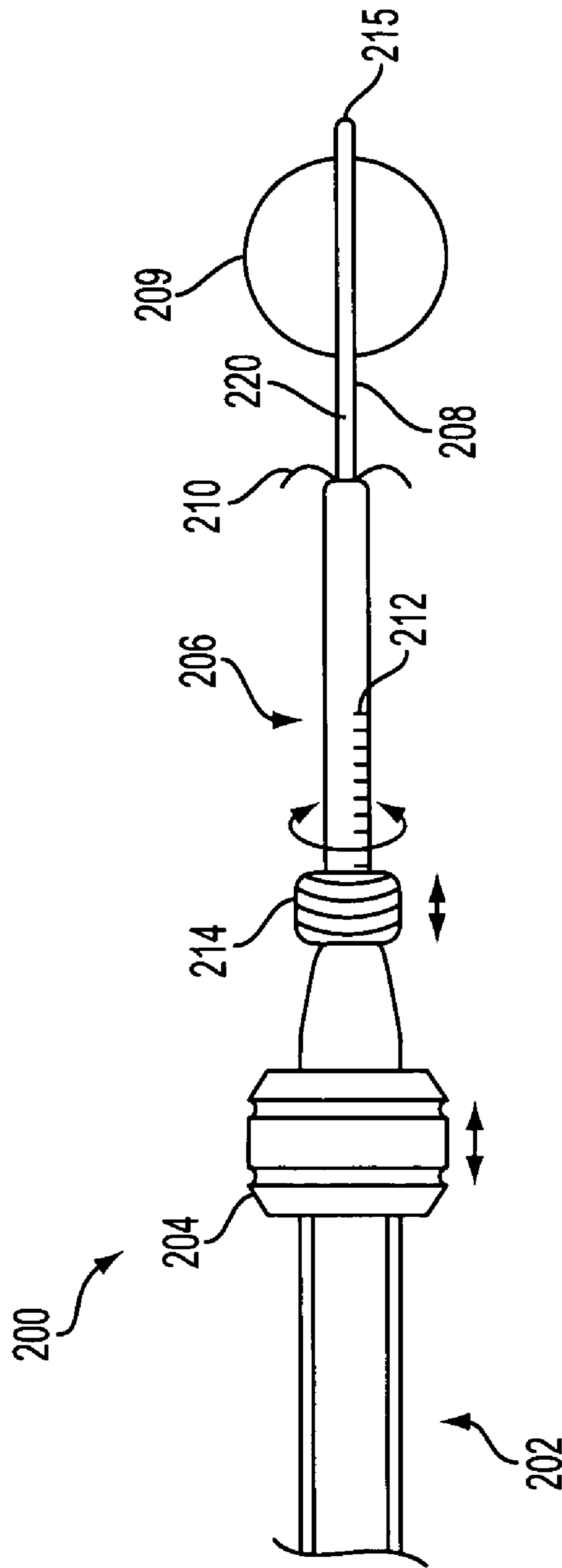

FIG. 9

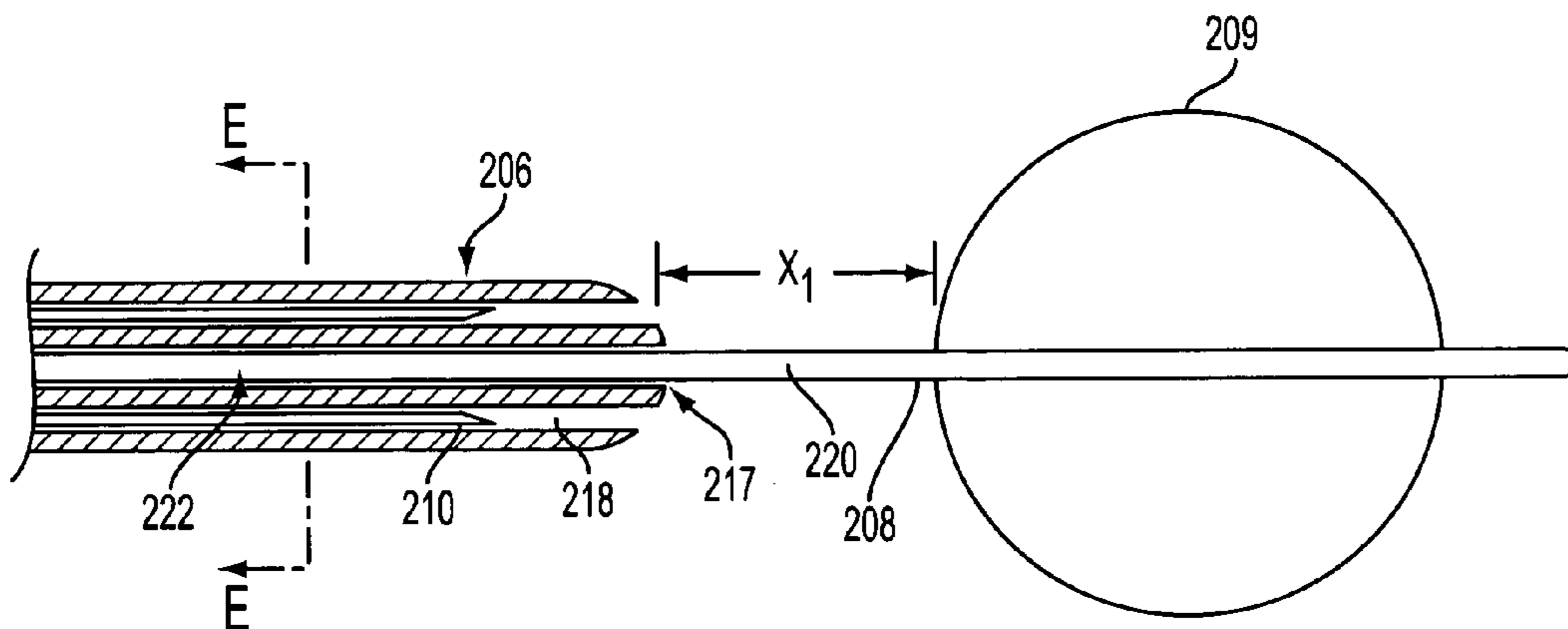

FIG. 10A

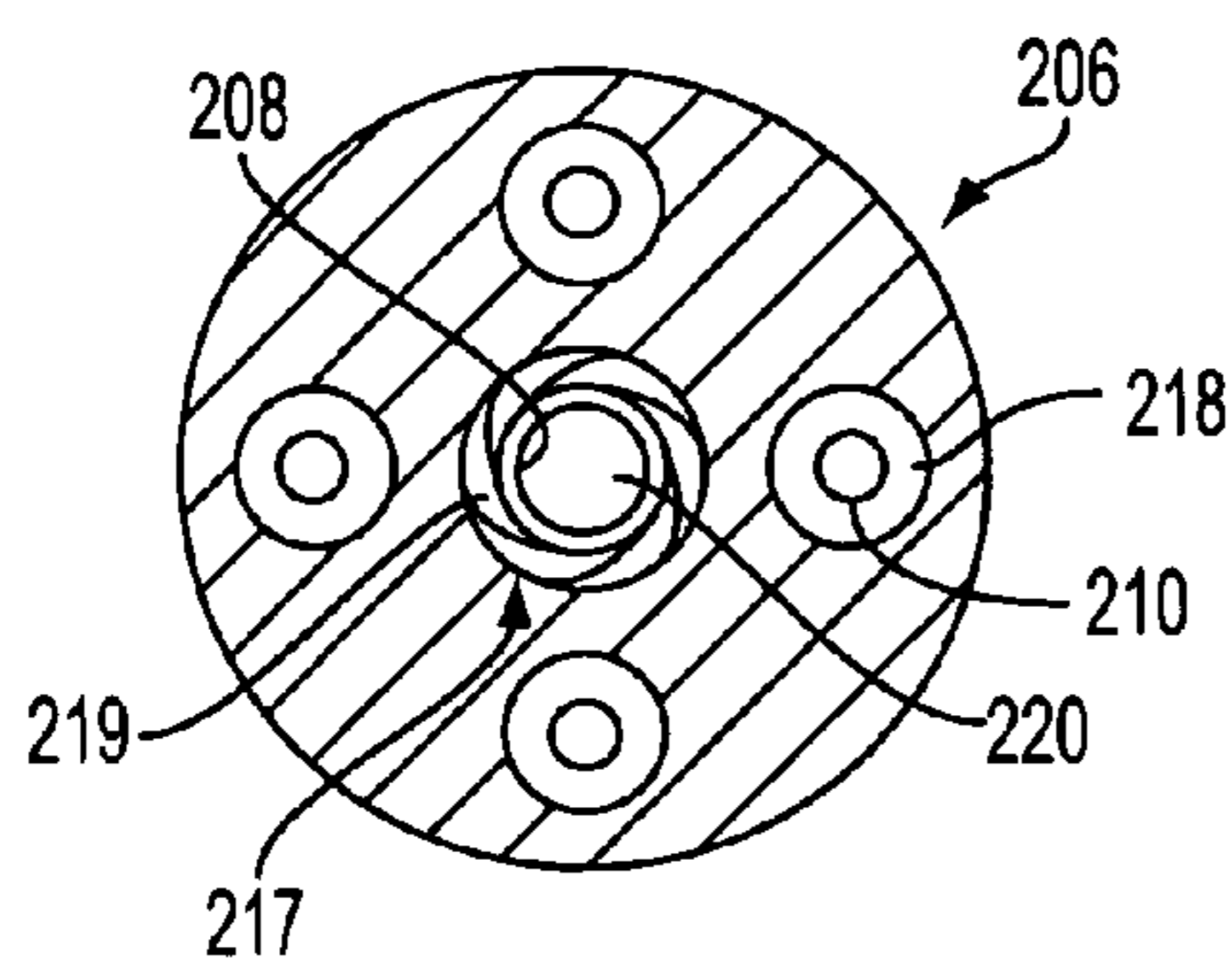

FIG. 10B

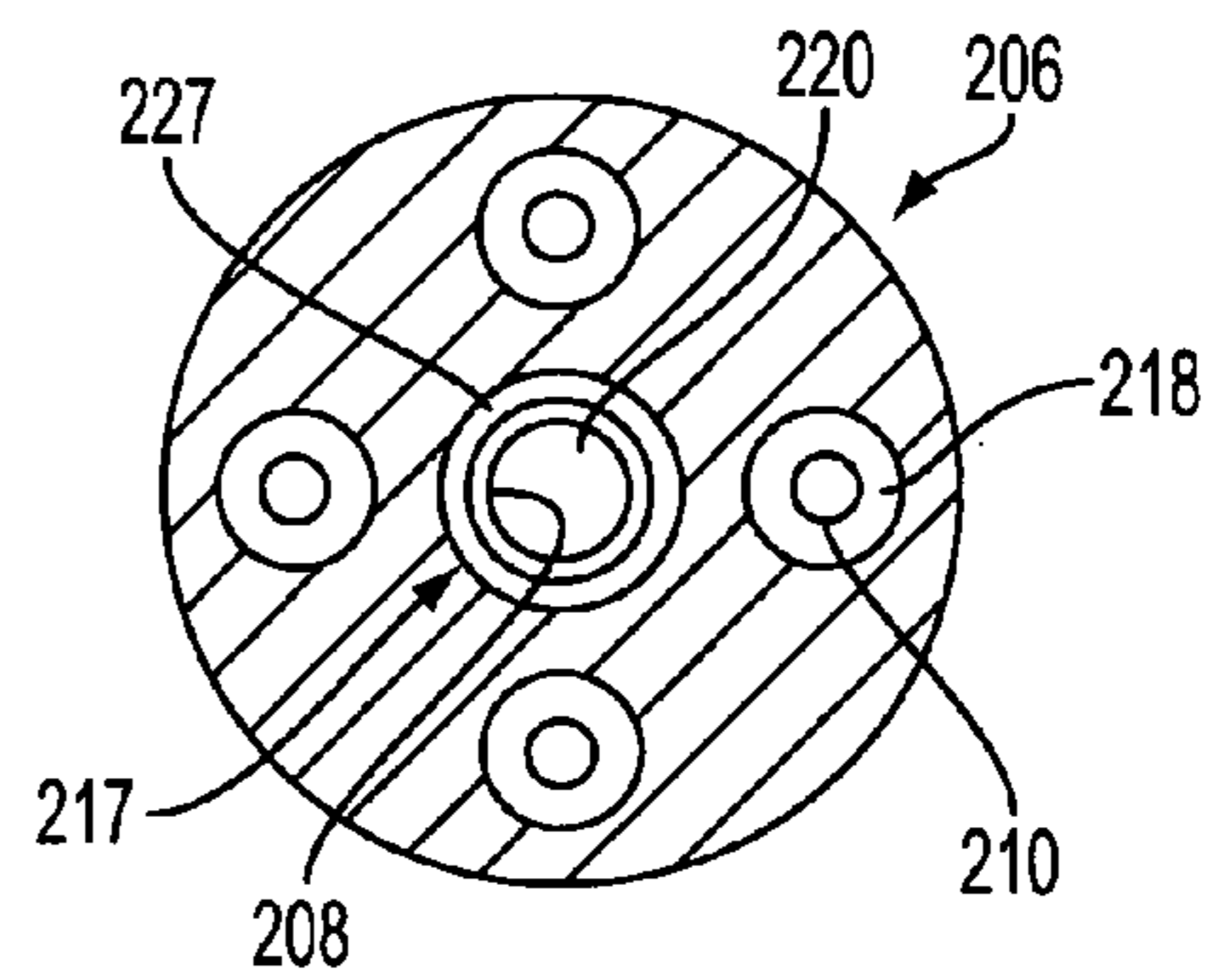

FIG. 10C

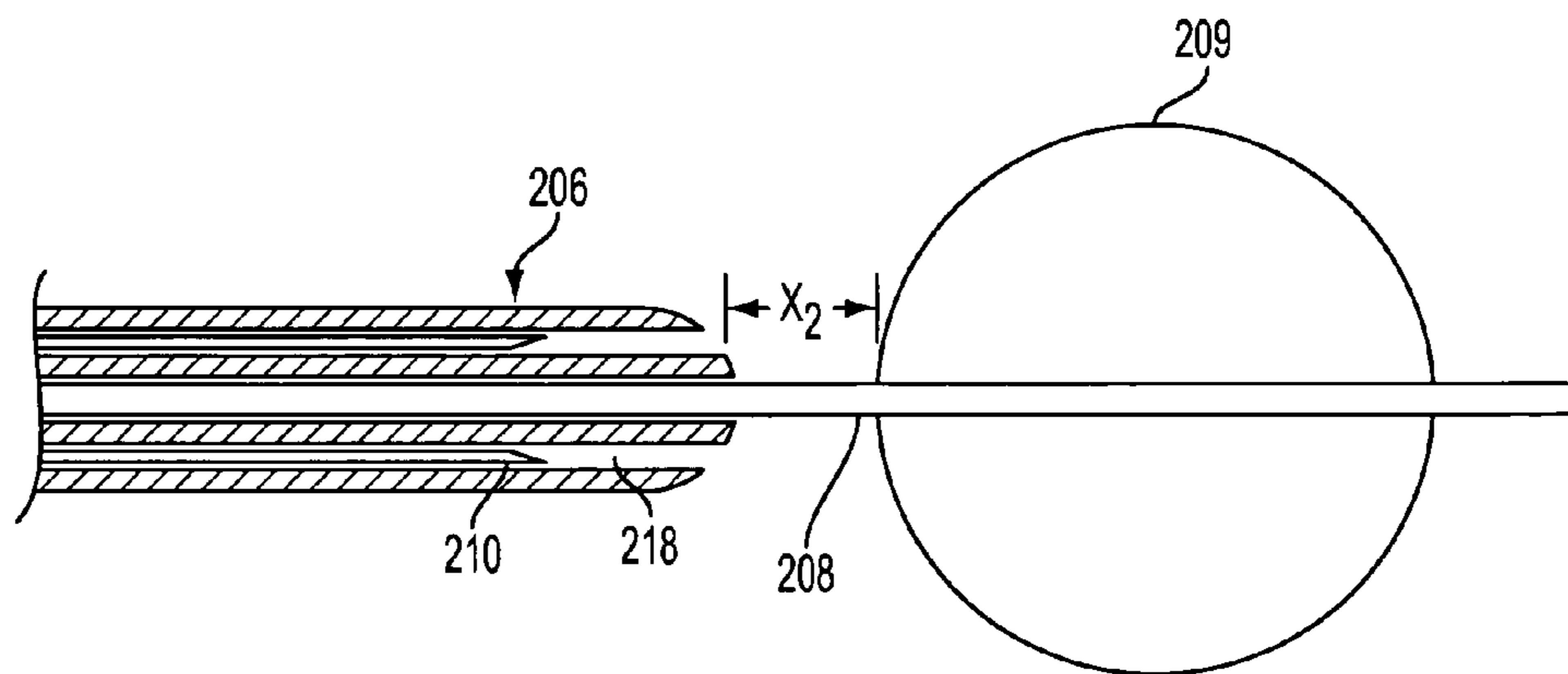

FIG. 10D

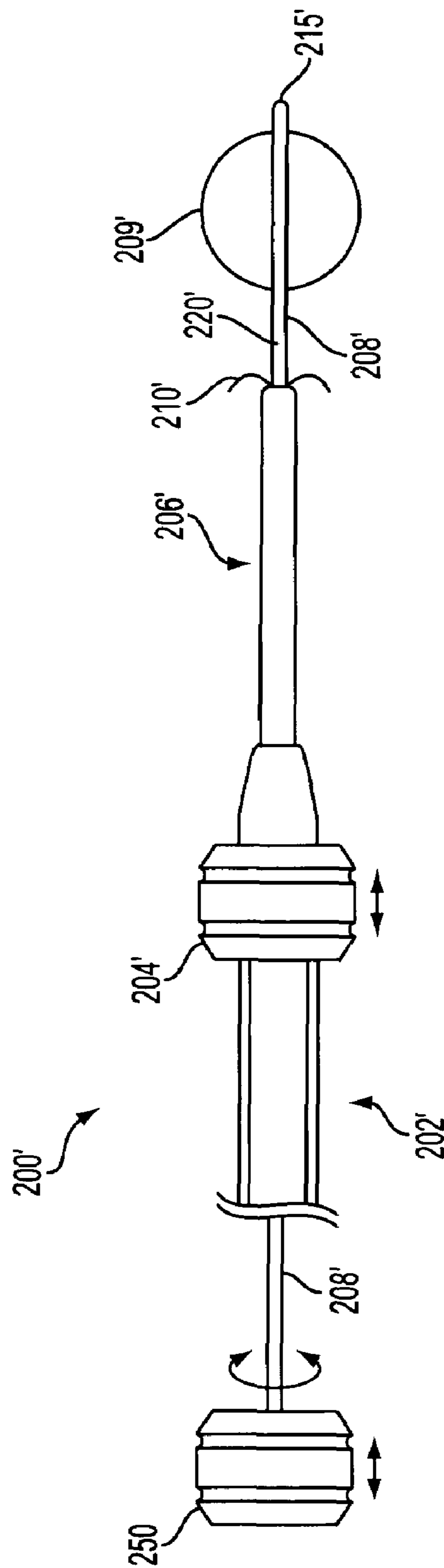

FIG. 11

1

**APPARATUS AND METHODS FOR
TREATING FEMALE URINARY
INCONTINENCE**

REFERENCE TO RELATED APPLICATIONS

The present application is a continuation-in-part of U.S. patent application Ser. No. 10/207,689, filed Jul. 25, 2002, which is a continuation-in-part of U.S. patent application Ser. No. 09/678,500, now U.S. Pat. No. 6,470,219, filed Oct. 2, 2000.

FIELD OF THE INVENTION

This invention relates to apparatus and methods for treating urinary incontinence, and more particularly, for treating female urinary incontinence in humans by applying a selected form of energy to tissue in the vicinity of the urethra and/or bladder outlet to cause a change in tissue compliance without substantially narrowing the urethral lumen and/or bladder outlet.

BACKGROUND OF THE INVENTION

The term "urinary incontinence" refers to the involuntary leakage of urine from the body in an uncontrolled manner. One cause of incontinence is increased mobility of the bladder outlet (bladder outlet hypermobility) where the bladder and proximal urethra do not maintain their normal anatomic positions during transient periods of increased bladder pressure due to increased intra-abdominal pressure. In addition, there is a small region of circular muscle surrounding the middle portion of the urethra in the female called the "urethral sphincter," which also participates in the controlled release of urine from the bladder. If the bladder outlet becomes too mobile and/or if the urinary sphincter or any other part of the urinary system malfunctions, the result may be urinary incontinence.

Urinary incontinence can generally be characterized into two types, one of which is called "stress incontinence" and the other "urge incontinence." Stress incontinence refers to involuntary loss of urine during coughing, laughing, sneezing, jogging or other physical activity that causes a sufficient increase in intra-abdominal pressure. Urge incontinence refers to the involuntary loss of urine due to unwanted bladder contraction that may be associated with an uncontrollable desire to urinate. "Mixed incontinence" refers to a combination of both urge and stress incontinence.

Heretofore, many different types of treatment have been utilized to treat female urinary incontinence including surgical and non-surgical procedures including the injection, under cystoscopic and/or fluoroscopic visualization, of collagen or other material into the tissue surrounding or adjacent to the bladder outlet and/or proximal urethra. In addition, drug therapy also has been utilized, for example, drugs to treat the detrusor muscle, which is the bladder wall muscle responsible for contracting and emptying the bladder. All of these procedures and therapies have drawbacks, are relatively expensive, and in the case of injections, require the equipment and training necessary to perform cystoscopic and/or fluoroscopic visualization of the urethra and bladder outlet. There is therefore a need for a new and improved apparatus and method for treatment of female urinary incontinence.

In view of the drawbacks of previously-known devices, it would be desirable to provide apparatus and methods for treating female urinary incontinence using an elongated

2

shaft configured to be introduced via the urethral orifice and advanced through the urethral lumen to enable energy delivery to surrounding tissue.

It further would be desirable to provide apparatus and methods for treating female urinary incontinence that allow a physician to remodel the urethral wall and/or bladder outlet without the need for a visualization device, e.g., a cystoscope or fluoroscope.

It still further would be desirable to provide apparatus and methods for treating female urinary incontinence by techniques that do not carry risks associated with surgical incisions, such as infection and herniation, and do not result in external scarring.

SUMMARY OF THE INVENTION

In view of the foregoing, it is an object of the present invention to provide apparatus and methods for treating female urinary incontinence using an elongated shaft configured to be introduced via the urethral orifice and advanced through the urethral lumen to enable energy delivery to surrounding tissue.

It further is an object of the present invention to provide apparatus and methods for treating female urinary incontinence that allow a physician to remodel the urethral wall and/or bladder outlet without the need for a visualization device, e.g., a cystoscope or fluoroscope.

It still further is an object of the present invention to provide apparatus and methods for treating female urinary incontinence by techniques that do not carry risks associated with surgical incisions, such as infection and herniation, and do not result in external scarring or require dressings or bandages.

These and other objects of the present invention are accomplished by providing apparatus comprising a handle, an elongated shaft having a distal region, an expandable member, and means for treating the submucosal layer of the urethral wall and/or bladder outlet to cause a change in tissue compliance without substantially narrowing the urethral and/or bladder outlet lumen.

In a preferred embodiment, the handle is coupled to a proximal end of the elongated shaft and is manipulated by the physician to insert the distal region into a patient's urethra, either individually or using an appropriate introducer sheath. The handle includes an actuator for deploying the expandable member.

In accordance with one aspect of the present invention, the expandable member is deployable at a predetermined distance distal of the means for treating. The expandable member may comprise a balloon or mechanically actuated basket that is configured to be moved between a contracted position, which permits insertion of the expandable member through the urethra and into the patient's bladder, and a deployed position, wherein the expandable member anchors against the bladder outlet. The expandable member facilitates tactile alignment of the means for treating at a desired treatment site, without the need for direct visualization.

In one embodiment of the present invention, the means for treating comprises at least one needleless electrode embedded in a lateral surface of the elongated shaft. The needleless electrode is coupled to a radio frequency generator/controller that causes the electrode to reach a desired temperature to heat the urethral tissue. In accordance with principles of the present invention, cooling fluid is provided in the vicinity of the electrode to cool the urethral and bladder outlet mucosa during the provision of RF energy. The application of RF energy causes denaturation of collagen in small

localized areas where treatment is delivered. Following cessation of energy delivery, these microscopic foci of denatured collagen renature and heal, ultimately creating minute areas of decreased tissue compliance without substantial anatomic change.

In an alternative embodiment of the present invention, the means for treating comprises an ultrasound transducer disposed on the elongated shaft. The ultrasound transducer is coupled to an ultrasound generator/controller. Ultrasound beams generated by the transducer may be focused in accordance with known techniques to cause a rise in tissue temperature at a desired distance beneath the mucosal layer of the urethra. Collagen denaturation and subsequent renaturation caused by the rise in temperature changes the tissue compliance in the vicinity of the urethra and/or bladder outlet without substantial anatomic change.

In a further alternative embodiment of the present invention, the means for treating comprises at least one hollow needle having contracted and deployed states and a cryogenic probe adapted to be inserted through the hollow needle. In the contracted state, the hollow needle is disposed within the confines of the elongated shaft, while in the deployed state, the hollow needle extends beyond the elongated shaft to pierce through urethral tissue and/or bladder outlet mucosa. The cryogenic probe is advanced through the hollow needle to a treatment site within the urethral tissue to locally freeze tissue and cause necrosis, which in turn causes remodeling of tissue in the vicinity of the urethra and/or bladder outlet.

Methods of using the apparatus of the present invention to induce localized areas of decreased tissue compliance, and to reduce or eliminate the effects of urinary incontinence, also are provided.

BRIEF DESCRIPTION OF THE DRAWINGS

Further features of the invention, its nature and various advantages will be more apparent from the accompanying drawings and the following detailed description of the preferred embodiments, in which:

FIGS. 1A-1E are, respectively, side and side sectional views of a device to treat urinary incontinence, cross-sectional views along lines A-A and B-B of FIG. 1B, and a schematic view depicting use of apparatus of FIG. 1A;

FIGS. 2A-2C are, respectively, a side view of a first embodiment of the present invention and side sectional views of alternative means for cooling the mucosa in conjunction with the apparatus of FIG. 2A;

FIG. 3 is a schematic view depicting the use of apparatus of FIG. 2;

FIG. 4 is a side view of an alternative embodiment of the present invention;

FIG. 5 is a schematic view depicting the use of apparatus of FIG. 4;

FIGS. 6A-6C are, respectively, a side view of a further alternative embodiment of the present invention, and cross-sectional views along lines C-C and D-D of FIG. 6A;

FIG. 7 is a schematic view depicting the use of apparatus of FIG. 6;

FIGS. 8A-8B are side sectional views illustrating the use of an alternative expandable member;

FIG. 9 is a side view of a device that allows movement of a means for treating with respect to an expandable member;

FIGS. 10A-10D are, respectively, a side sectional view of apparatus of FIG. 9 in a first position, cross-sectional views along line E-E of FIG. 10A illustrating two alternative

configurations, and a side sectional view of apparatus of FIG. 9 in a second position; and

FIG. 11 is a side view of a device that allows movement of an expandable member with respect to a means for treating.

DESCRIPTION OF THE PREFERRED EMBODIMENTS

Referring now to FIG. 1, a device to treat urinary incontinence, described in U.S. patent application Ser. No. 09/678,500, which is herein incorporated by reference in its entirety, is shown. Apparatus 20 comprises semi-rigid elongated tubular shaft 22 having proximal and distal extremities 23 and 24, distal region 72, and lumen 26 extending from proximal extremity 23 to distal extremity 24.

Handle 31 has proximal and distal ends, and is configured to be grasped by the human hand. The distal end of handle 31 is coupled to proximal extremity 23 of elongated shaft 22. The proximal end of handle 31 preferably comprises rear surface 33 through which electrical connector 34 extends. Handle 31 further comprises fluid-in port 36, fluid-out port 37 and, optionally, auxiliary port 39.

It will be apparent to those skilled in the art that handle 31 may comprise any suitable exterior shape that is configured to be grasped by a human hand, and is not intended to be limited by the exterior shapes depicted herein. An illustrative, alternative handle shape is depicted in commonly-assigned U.S. patent application Ser. No. 10/207,689, which is herein incorporated by reference in its entirety.

Plurality of needle electrodes 41-44, which are sharpened at their distal extremities, are disposed within distal region 72 of elongated shaft 22 in a contracted state. Needle electrodes 41-44 assume a preformed shape in a deployed state, i.e., when they are no longer constrained within elongated shaft 22, and preferably comprise a shape-memory material such as a nickel-titanium alloy. In the deployed state, needle electrodes 41-44 curve outwardly and downwardly to provide a fishhook-like configuration, as shown in FIG. 1A. Needle electrodes 41-44 are disposed in suitable angular positions, as for example, spaced circumferentially in a single plane 90° apart. This is accomplished by slideably mounting needle electrodes 41-44 in plurality of PEEK hypo tubes 46 in four spaced-apart lumens 47 of Pebax block 48, as shown in FIG. 1D.

Pebax block 48 is mounted in a fixed position in distal region 72 of elongated shaft 22. Needle electrodes 41-44 extend proximally through hypo tubes 46 and are mounted in fixed positions in four lumens 49 spaced apart in Pebax block 51, as shown in FIG. 1C.

Pebax block 51 is slideably mounted within elongated shaft 22. Rod 53 has a distal extremity mounted in a fixed position in centrally disposed lumen 54 of block 51 and extends proximally from block 51 and into recess 56 of handle 31. Slide block 58 has outwardly extending protrusion 59 coupled to rod 53, as shown in FIG. 1B. Knob 57 is slideably mounted on the exterior of handle 31 and is secured to protrusion 59, e.g., using a screw. Movement of knob 57 longitudinally with respect to handle 31 causes needle electrodes 41-44 to be moved between extended and retracted positions in hypo tubes 46.

Cooling liquid preferably is supplied via elongated shaft 22 so that it is discharged in the vicinity of needle electrodes 41-44 via tubing 61. Tubing 61 is in turn connected to fitting 36. Tubing 62 is connected to fitting 37 and extends distally into lumen 26 of tubular member 22, through block 51, and terminates at block 48, where it is placed in communication

5

with return lumen 63 in block 48. Tubing 61 continues through block 48 and opens into shaft 66, which extends distally from block 48.

Expandable member 55 is disposed on shaft 66 and illustratively comprises a balloon. As will be described hereinbelow with respect to FIGS. 8A-8B, expandable member 55 alternatively may comprise a mechanically self-deployable basket.

Shaft 66 has openings 60 disposed within expandable member 55. Openings 60 are in fluid communication with tubing 61 and are used to inflate expandable member 55. Expandable member 55 is provided with plurality of openings 74 through which the cooling liquid introduced into expandable member 55 may escape and be discharged in the vicinity of needle electrodes 41-44 to cool the tissue being treated, as hereinafter described. The cooling liquid, after it has performed its function, is aspirated through central return lumen 63 to fitting 37. Alternatively, openings 74 may be disposed directly in a lateral surface of shaft 22, as depicted by openings 74' in FIG. 1B.

Fittings 36 and 37 are connected by tubing 75 to irrigation pump/controller 64, as depicted in FIG. 1A. Controller 64 supplies a cooling liquid, such as room temperature water, to fitting 36 and may also aspirate the liquid through fitting 37 after it has been used.

Plurality of insulated wires 65 are connected to electrical connector 34 with slack being provided within handle 31. Electrical connector 34 is adapted to be connected to RF generator/controller 68 by cable 69, as depicted in FIG. 1A.

Wires 65 extend distally through lumen 26 of elongated shaft 22, through lumens in blocks 48 and 51, and are coupled to four thermocouple wires (not shown) extending through hollow needles 41-44. The thermocouple wires are connected to thermocouples 67, which are mounted in sharpened tips of needles 41-44 for measuring needle-tip temperatures, as shown in FIG. 1B.

Referring now to FIG. 1E, a preferred method for treating urinary incontinence using apparatus 20 is described. Atraumatic tip 71, which is disposed distal of expandable member 55, is inserted into urethra U of a patient with expandable member 55 and needles 41-44 being provided in contracted states. Elongated shaft 22 is distally advanced within urethra U so that expandable member 55 is positioned within bladder B, e.g., using markings 76 of FIG. 1B. Expandable member 55 then is deployed, e.g., by inflating a balloon via fluid-in port 36. Expandable member 55 then is retracted proximally so that expandable member 55 is anchored against bladder outlet O, as shown in FIG. 1E.

After expandable member 55 has been seated against bladder outlet O, a physician distally advances knob 57 with respect to handle 31 to cause needles 41-44 to be advanced from their retracted positions within distal region 72 of elongated shaft 22. Needles 41-44 move distally and side-wise beyond the outer cylindrical profile of elongated shaft 22 and into the urethral tissue in the vicinity of bladder outlet O, as shown in FIG. 1E.

After needles 41-44 have been deployed, radio frequency energy is supplied from RF generator/controller 68. As is well known to those skilled in the art, such a generator may be configured to provide impedance readings that give an indication of whether or not needle electrodes 41-44 have been properly positioned within the tissue.

Liquid is introduced in the vicinity of needle electrodes 41-44 via irrigation pump/controller 64 and openings 74, as described hereinabove, to cool the mucosal layer of the urethral wall. Radio frequency energy then is supplied to the needle electrodes at a power level ranging from 1 to 10 watts

6

for a period of time ranging from 60 to 90 seconds to achieve approximately an 70° C. temperature in the tissue being treated, while the overlying mucosal tissue is preserved by the cooling liquid flow. In accordance with one aspect of the present invention, it is desirable that the tissue not to reach a temperature of 100° C. Therefore, RF generator 68, utilizing the information supplied from thermocouples 67, is programmed to automatically turn off if the temperature reaches a pre-set temperature, e.g., 80° C. Otherwise, for the duration of the treatment, the RF power is adjusted to maintain the tissue being treated at the desired target temperature.

Once the first RF treatment has been completed, the radio frequency energy is turned off and knob 57 is retracted to withdraw needle electrodes 41-44 into their retracted positions within distal region 72 of elongated shaft 22. The device then may be rotated a predetermined angle, the needles redeployed and another radio frequency energy treatment may be applied to surrounding tissue. During this entire procedure, irrigation liquid is introduced through openings 74 of expandable member 55 and/or openings 74' of shaft 22. As the irrigation fluid progressively fills the bladder during each RF treatment, the geometry of the bladder outlet changes as the bladder is filled such that repeated seating of the expandable member results in the electrode location moving progressively towards the bladder outlet.

In connection with the RF treatments described hereinabove, tiny sites of collagen in the vicinity of the treatment site renature over the ensuing weeks. Such treatment results in changes in tissue compliance of the bladder outlet and/or urethral walls to cause a significant improvement in urinary incontinence.

Referring now to FIGS. 2-3, a first embodiment of the present invention that utilizes a plurality of needleless electrodes to treat urinary incontinence is described. Apparatus 80 comprises elongated shaft 82 having proximal and distal ends and distal region 86 disposed adjacent to the distal end. Handle 84 is provided in accordance with handle 31 of FIG. 1, except as noted below, and is coupled to the proximal end of elongated shaft 82.

Elongated shaft 82 further comprises at least one needleless electrode 90 capable of transmitting radio frequency energy. Needleless electrode 90 may comprise a hollow, curved surface, as depicted in FIGS. 2B-2C, and preferably is manufactured from stainless steel. Needleless electrode 90 preferably is embedded into a lateral surface of elongated shaft 82 so that curved regions 107 and 108 of electrode 90 extend within an interior portion of elongated shaft 82, while outer surface 101 of electrode 90 is disposed outside of and faces away from elongated shaft 82, as shown in FIGS. 2B-2C.

Elongated shaft 82 further comprises irrigation port 91 and optional aspiration port 92, which are coupled to irrigation tubing 104 and aspiration tubing 105, respectively. Irrigation tubing 104 and aspiration tubing 105 extend proximally from their respective ports 91 and 92, through elongated shaft 82 and handle 84, and are coupled to fluid-in and fluid-out ports 93 and 94, respectively. Fluid-in and fluid-out ports 93 and 94 in turn are coupled to fluid controller 106.

In FIGS. 2A and 2B, irrigation and aspiration ports 91 and 92 are illustratively disposed in a lateral surface of elongated shaft 82 adjacent to electrode 90. In an alternative embodiment shown in FIG. 2C, irrigation and aspiration ports 91 and 92 may be omitted and irrigation and aspiration tubing 104 and 105 may be coupled to first and second curved ends

107 and 108 of hollow electrode 90, respectively. In this embodiment, fluid infused into irrigation tubing 104 flows through hollow electrode 90 to provide a cooling effect upon outer surface 101, then is aspirated through tubing 105.

Apparatus 80 of FIG. 2 further comprises wire 98 and thermocouple wire 99, each having proximal and distal ends. The distal ends of wire 98 and thermocouple wire 99 are coupled to needleless electrode 90, as shown in FIGS. 2B-2C, while the proximal ends extend through elongated shaft 82 and handle 84. Wire 98 and thermocouple wire 99 preferably are coupled to electrical connector 110 of handle 84, which in turn is connected to RF generator/controller 109 by cable 111.

Apparatus 80 further comprises expandable member 87 that is deployable at a predetermined distance distal of needleless electrode 90. Expandable member 87 may comprise a balloon that is disposed on distal region 86 or, alternatively, a self-expanding mechanical basket as described hereinbelow with respect to FIGS. 8A-8B.

Referring now to FIG. 3, a preferred method for using apparatus 80 of FIG. 2A is described. In a first step, atraumatic tip 85 at the distal end of elongated shaft 82 is inserted into a patient's urethra U with expandable member 87 in a contracted state. Expandable member 87 is positioned within bladder B, e.g., using measurement indicia 96 disposed near the proximal end of elongated shaft 82 (see FIG. 2A). Expandable member 87 is deployed and handle 84 is retracted proximally so that expandable member 87 is anchored against bladder outlet O.

In accordance with the present invention, retracting expandable member 87 against bladder outlet O positions needleless electrodes 90 at a desired treatment site within urethra U using only tactile feedback. Once properly positioned, liquid is introduced to irrigation port 91 via irrigation pump 106 to provide a cooling effect to mucosal layer M of the urethra. Radio frequency energy then is supplied to needleless electrode 90 to achieve a temperature of approximately 70° C. in the tissue being treated, i.e., the submucosal tissue S of the urethral wall. The overlying mucosal tissue M is preserved by the cooling liquid flow. Preferably, the submucosal tissue is not heated to a temperature significantly higher than 70° C. Therefore, RF generator 109, utilizing the information supplied from thermocouple 97, preferably is programmed to automatically turn off if the temperature reaches a pre-set temperature, as for example, 80° C. Otherwise, for the duration of the treatment, the RF power is adjusted to maintain the submucosal tissue at the desired target temperature.

After this first RF treatment has been completed, the radio frequency energy is turned off and the device can be advanced into the bladder lumen and rotated a predetermined angle so that needleless electrode 90 may contact a new interior surface of urethra U. Once electrode 90 has been rotated to the desired angle, handle 84 is retracted proximally to seat expandable member 87 in bladder outlet O, and RF energy is provided to needleless electrode 90, as described hereinabove. Upon completion of the procedure, expandable member 87 is contracted and elongated shaft 82 is removed from the patient's urethra.

As described hereinabove with respect to the embodiment of FIGS. 1A-1E, the RF treatments produce collagen denaturation in small, localized areas where the treatment is delivered, followed by collagen renaturation and remodeling over the ensuing weeks and months, thereby resulting in changes in tissue compliance within the urethra and/or bladder outlet.

Referring now to FIGS. 4-5, a further alternative embodiment of the present invention is described wherein high intensity focused ultrasound (HIFU) is applied to treat urinary incontinence. HIFU involves directing high intensity ultrasound waves at the selected tissue to create heat in a precise area and cause coagulation and tissue necrosis.

In FIG. 4, apparatus 120 comprises elongated shaft 121 having proximal and distal ends and distal region 122 disposed adjacent to the distal end. Handle 128 is coupled to the proximal end of elongated shaft 121 and may comprise inflation port 137 that is in fluid communication with expandable member 123, illustratively a balloon. Alternatively, expandable member 123 may comprise a self-expanding mechanical basket as described hereinbelow with respect to FIGS. 8A-8B.

Elongated shaft 121 further comprises therapeutic ultrasound transducer 124 disposed on elongated shaft 121 just proximal of distal region 122. Ultrasound transducer 124 is capable of transmitting at therapeutic ultrasound frequencies. Transducer 124 preferably comprises an annular phased array, and is coupled to a transmission cable (not shown) disposed in a lumen of elongated shaft 121. The transmission cable extends proximally and is coupled to electrical connector 129 of handle 128. Electrical connector 129 in turn is connected to ultrasound generator/controller 131 by cable 130, as depicted in FIG. 4.

Referring now to FIG. 5, a preferred method of using apparatus 120 of FIG. 4 is described. Atraumatic tip 132 at the distal end of elongated shaft 121 is inserted into a patient's urethra U with expandable member 123 in a contracted state. Expandable member 123 is positioned within a patient's bladder B, e.g., using measurement indicia 133 of FIG. 4. Expandable member 123 then is deployed and handle 128 is retracted proximally so that expandable member 123 is anchored against bladder outlet O. In accordance with the present invention, retracting expandable member 123 against bladder outlet O positions transducer 124 at a desired treatment site within urethra U using only tactile feedback.

Ultrasound generator/controller 131 is turned on and set to the desired frequency to cause transducer 124 to emit ultrasonic beams. Ultrasound beams 126 are focused to cause a rise in tissue temperature at a desired distance beneath mucosal layer M of urethra U. The heating of the desired submucosal tissue causes localized denaturation of the tissue. The change in submucosal tissue created by the denaturation and renaturation of the collagen results in changes in tissue compliance of the urethral wall and/or bladder outlet, thereby reducing urinary incontinence.

Referring now to FIGS. 6-7, a further alternative embodiment of the present invention is described whereby cryogenic therapy is used to treat urinary incontinence by controlled freezing of selected urethral tissue.

In FIG. 6A, cryogenic therapy apparatus 140 comprises elongated shaft 142 having proximal and distal ends and reduced diameter distal region 144 disposed adjacent to the distal end. Handle 141 is coupled to the proximal end of elongated shaft 142 and may comprise inflation port 159 that is in fluid communication with expandable member 145, illustratively a balloon. Alternatively, expandable member 145 may comprise a self-expanding mechanical basket as described hereinbelow with respect to FIGS. 8A-8B.

Apparatus 140 further comprises at least one hollow needle 143 and cryogenic probe 152. Needle 143 has proximal and distal ends and sharpened tip 147 disposed at the distal end. The proximal end of each hollow needle 143 is coupled to knob 146. Although four hollow needles are

illustrated in FIG. 6C, it will be apparent to those skilled in the art that greater or fewer needles may be used.

Handle **141** further comprises proximal port **150** having at least one probe insertion hypotube **151**, as depicted in FIG. 6B. Each probe insertion hypotube **151** corresponds to a 5 respective needle **143**. Each probe insertion hypotube **151** comprises an outer diameter that preferably is slightly smaller than an inner diameter of hollow needle **143**. A proximal end of each probe insertion hypotube **151** is affixed to proximal port **150** while a distal end of each hypotube **151** extends into the proximal end of its respective hollow needle **143** to create an overlap between the distal end of the hypotube and the proximal end of the needle, as shown in FIG. 6C. This overlap allows needles **143** to move with respect to probe insertion hypo tubes **151** when knob **146** is actuated.

Cryogenic probe **152** has proximal and distal ends and tip **153** disposed at the distal end. Handle **154** is coupled to the proximal end of cryogenic probe **152** and is configured to be grasped by a physician. Cryogenic probe **152** is powered and controlled by cryogenic generator **156** via wire **155**, which is coupled to handle **154**. Cryogenic probe **152** comprises an outer diameter configured to be inserted into probe insertion hypotube **151** and through hollow needle **143**.

Referring now to FIG. 7, a preferred method of using apparatus **140** of FIG. 6A to treat urinary incontinence is described. Atraumatic tip **157** at the distal end of elongated shaft **142** is inserted into a patient's urethra U with needle **143** in a contracted state, i.e., retracted within the confines of elongated shaft **142**, and also with expandable member **145** provided in a contracted state. Expandable member **145** is positioned within a patient's bladder B, e.g., using measurement indica **158**. Expandable member **157** then is deployed within bladder B and handle **141** is retracted proximally so that expandable member **157** is anchored against bladder outlet O. In accordance with one aspect of the present invention, retracting expandable member **157** against bladder outlet O positions needle **143**, when deployed, at a desired treatment site within urethra U using only tactile feedback.

Needle **143** then is actuated by distally advancing knob **146**, which urges needle **143** to extend beyond elongated shaft **142**, pierce mucosal layer M of urethra U, and extend into submucosal layer S. Needle **143** preferably comprises a shape-memory material that causes the distal end to curve to a predetermined shape when needle **143** is no longer confined within elongated shaft **142**.

Cryogenic probe **152** then is inserted into probe insertion hypotube **151** at proximal port **150** and is advanced distally via probe insertion hypotube **151** into hollow needle **143**. Cryogenic probe **152** is advanced distally until it extends distal of needle **143** and into submucosal layer S of the urethra, as shown in FIG. 7. Needle **143**, having a larger diameter relative to probe **152**, serves to dilate the submucosal tissue prior to insertion of the probe so that the probe encounters reduced resistance from the tissue.

Cryogenic generator **156** is turned on and set to the desired temperature, which preferably is between about -80° F. and -110° F., to cause local regions of the submucosal tissue to freeze. The local regions of tissue and tip **153** may freeze together for about three minutes, after which time probe **152** is defrosted and removed from within elongated shaft **142** and handle **141**. If desired, a physician then may re-insert probe **152** into a different insertion hypotube **151** and the procedure may be repeated through a different needle **143** to treat another region within submucosal layer S. In accordance with principles of the present

invention, the application of cryogenic probe **152** to the submucosal tissue causes small localized regions of submucosal tissue to undergo necrosis, after which tissue healing ensues. This results in altered tissue elasticity, tensile strength, and tissue compliance in the urethra and/or bladder outlet, and causes a significant improvement in urinary incontinence.

Referring now to FIGS. 8A-8B, an alternative expandable member is described for use with any of the treatment techniques described hereinabove. Apparatus **170** comprises self-expandable basket **172**, shown in a deployed state in FIG. 8B, instead of a balloon. Basket **172** preferably comprises a plurality of flexible struts **171** joined to rod **176** via hinges **180**. Struts **171**, which may be covered by a biocompatible elastomeric membrane (not shown), are constrained in a contracted position within central lumen **177** of elongated shaft **181**, as illustrated in FIG. 8A. Struts **171**, which preferably comprise a shape-memory material such as Nitinol, assume a predetermined curvature extending radially outward from elongated shaft **181** in the deployed state, i.e., when struts **171** are no longer effectively constrained within central lumen **177**, as shown in FIG. 8B.

Rod **176** has proximal and distal ends and is disposed through central lumen **177**. Preferably, rod **176** includes atraumatic distal tip **178** disposed at the distal end. The proximal end of rod **176** is configured to be manipulated by a physician.

In operation, atraumatic tip **178** and elongated shaft **181** are inserted into the patient's urethra in a manner described hereinabove. Once distal end **184** of elongated shaft **181** is positioned within a patient's bladder, the proximal end of rod **176** is advanced distally by a physician to self-deploy mechanically expandable basket **172**, as depicted in FIG. 8B. Once basket **172** is deployed within the bladder, elongated shaft **181** and rod **176** are retracted proximally to cause basket **172** to become anchored against the bladder outlet.

At this time, needles **183** may be deployed from elongated shaft **181** to penetrate the urethral wall to perform a radio frequency treatment of the tissue. Alternatively, needles **183** may be omitted and needleless radio frequency waves or ultrasound beams may be used to treat incontinence, as described hereinabove.

After the preferred treatment is completed, basket **172** is returned to the contracted configuration by retracting rod **176** proximally with respect to elongated shaft **181** to cause struts **171** to be contained within central lumen **177**.

Referring now to FIGS. 9-10, apparatus and methods for longitudinally advancing the spacing between the tissue treating elements and the expandable member are described. In FIG. 9, apparatus **200** is provided in accordance with apparatus **20** of FIG. 1, except as noted below. Apparatus **200** comprises handle **202** and knob **204**, which are similar in structure to handle **31** and knob **57** of FIG. 1, respectively.

Apparatus **200** further comprises elongated shaft **206** having proximal and distal ends and actuator **214** disposed about the proximal end. Measurement indica **212** preferably are provided on a lateral surface of elongated shaft **206**. Illustratively, needle electrodes **210** are shown for providing energy to the submucosal layer of the urethral wall, although it will be apparent that needleless electrodes, an ultrasound transducer or cryogenic probe, as described hereinabove, may be substituted for needle electrodes **210**.

Apparatus **200** further comprises shaft **208** having proximal and distal ends and expandable member **209** disposed on the distal end. Shaft **208** preferably is affixed to an interior surface of handle **202** and may include inflation

lumen 220 extending between the proximal and distal ends that communicates with expandable member 209.

Referring now to FIG. 10A, a side sectional view of the distal end of apparatus 200 is provided. Elongated shaft 206 preferably comprises central lumen 217 having an inner diameter slightly larger than an outer diameter of expandable member shaft 208. Inflation lumen 220 is in fluid communication with expandable member 209, while lumens 218 house needle electrodes 210 in the contracted state (see FIG. 10A).

Region 222 of shaft 208 may be threaded to provide threaded interface 219 between shaft 208 and central lumen 217 of elongated shaft 206, as shown in FIG. 10B. Threaded interface 219 provides for controlled longitudinal movement of elongated shaft 206 with respect to shaft 208 when actuator 214 of FIG. 9 is rotated circumferentially.

Referring to FIG. 10C, the threaded interface between elongated shaft 206 and shaft 208 is omitted and small gap 227 is provided between central lumen 217 and shaft 208. Gap 227 allows for straight translation of elongated shaft 206 with respect to shaft 208 when actuator 214 is longitudinally advanced and handle 202 is held stationary.

Using the technique of FIGS. 9-10, a physician may perform a first treatment at a distance of about x_1 from the bladder outlet, as shown in FIG. 10A, assuming that expandable member 209 is disposed within the bladder and then retracted against the bladder outlet. The physician then may perform a second treatment at a distance of about x_2 from the bladder outlet by actuator 214 as described hereinabove. Measurement indica 212 may be used as a distance guide when a physician manipulates the distance between x_1 and x_2 using actuation handle 214.

Referring now to FIG. 11, an alternative embodiment of apparatus configured to longitudinally advance the spacing between the tissue treating elements and the expandable member is described. In FIG. 11, apparatus 200' is provided substantially in accordance with apparatus 200 of FIGS. 9-10, except as noted below.

In the embodiment of FIG. 11, shaft 208' extends through elongated shaft 206' and preferably is coupled to actuator 250 instead of being affixed to an interior surface of handle 202', as described in the embodiment of FIGS. 9-10. Actuator 250 may be disposed about handle 202' in a manner similar to the manner in which knob 57 of FIG. 1 is disposed about handle 31, as described hereinabove. Alternatively, actuator 250 may be disposed proximal of handle 202'. For example, shaft 208' may extend through handle 202', through an aperture or port (not shown) disposed at the proximal end of handle 202', and then may be coupled to actuator 250 proximal of the handle.

Apparatus 200' may comprise a threaded interface between shaft 208' and a central lumen of elongated shaft 206', as described in FIG. 10B hereinabove. The threaded interface provides for controlled longitudinal movement of shaft 208' with respect to elongated shaft 206' when actuator 250 is rotated circumferentially and handle 202' is held stationary.

Alternatively, a small gap, such as described hereinabove with respect to FIG. 10C, may be provided between the central lumen of elongated shaft 206' and shaft 208'. This permits straight translation of shaft 208' with respect to elongated shaft 206' when actuator 250 is advanced or retracted and handle 202' is held stationary. Measurement indica (not shown) may be disposed on handle 202' or shaft 208' to determine the spacing between tissue treating elements 210' and expandable member 209'.

Handle 202' also may comprise a central lumen, e.g., as described hereinabove with respect to FIGS. 10B-10C, that guides shaft 208' through handle 202'. The central lumen of handle 202' may be used alone or in conjunction with the central lumen of elongated shaft 206' to serve as a guide for shaft 208' along the length of the device.

While preferred illustrative embodiments of the invention are described above, it will be apparent to one skilled in the art that various changes and modifications may be made therein without departing from the invention. The appended claims are intended to cover all such changes and modifications that fall within the true spirit and scope of the invention.

The invention claimed is:

1. An apparatus for remodeling at least one treatment site within the lower urinary tract of a female patient, the lower urinary tract including a urethra having a urethral lumen and a bladder having a bladder outlet, the apparatus comprising:

an elongated shaft having proximal and distal ends and a distal region disposed adjacent to the distal end;

a handle coupled to the proximal end;

a plurality of needles configured to selectively extend from within the shaft, the plurality of needles configured for treating a submucosal layer of the urethra or bladder outlet to cause a reduction in the compliance of the submucosal layer; and

an expandable member deployable at a predetermined distance distal of the plurality of needles, the expandable member adapted to be deployed in the bladder and anchored against the bladder outlet,

wherein the plurality of needles does not substantially narrow the urethral lumen and bladder outlet, and wherein the expandable member comprises a self-expandable basket.

2. The apparatus of claim 1, wherein the self-expandable basket comprises a plurality of flexible struts coupled to a rod, and wherein the rod is disposed within a central lumen of the elongated shaft.

3. The apparatus of claim 2, wherein the self-expandable basket comprises a contracted state, in which the plurality of flexible struts are constrained within the central lumen of the elongated shaft, and a deployed state, in which the plurality of flexible struts assume a predetermined curvature extending radially outward from the elongated shaft.

4. The apparatus of claim 3, wherein the plurality of flexible struts comprise a shape-memory material.

5. An apparatus for remodeling at least one treatment site within the lower urinary tract of a female patient, the lower urinary tract including a urethra having a urethral lumen and a bladder having a bladder outlet, the apparatus comprising:

an elongated shaft having proximal and distal ends and a distal region disposed adjacent to the distal end;

a handle coupled to the proximal end;

a plurality of needles configured to selectively extend from within the shaft, the plurality of needles configured for treating a submucosal layer of the urethra or bladder outlet to cause a reduction in the compliance of the submucosal layer; and

an expandable member deployable at a predetermined distance distal of the plurality of needles, the expandable member adapted to be deployed in the bladder and anchored against the bladder outlet,

wherein the plurality of needles does not substantially narrow the urethral lumen and bladder outlet, and wherein the elongated shaft further comprises a plurality of measurement indica suitable for use in positioning the expandable member within the bladder.

13

6. The apparatus of claim 5, wherein the expandable member comprises a balloon that is affixed to the distal region of the elongated shaft.

7. The apparatus of claim 5, further comprising at least one irrigation port disposed in a lateral surface of the elongated shaft and configured to provide irrigation fluid in the vicinity of the plurality of needles.

8. An apparatus for remodeling at least one treatment site within the lower urinary tract of a female patient, the lower urinary tract including a urethra having a urethral lumen and a bladder having a bladder outlet, the apparatus comprising:
 an elongated shaft having proximal and distal ends and a distal region disposed adjacent to the distal end;
 a handle coupled to the proximal end;
 a plurality of needles configured to selectively extend from within the shaft, the plurality of needles configured for treating a submucosal layer of the urethra or bladder outlet to cause a reduction in the compliance of the submucosal layer; and
 an expandable member deployable at a predetermined distance distal of the plurality of needles, the expandable member adapted to be deployed in the bladder and anchored against the bladder outlet, wherein the plurality of needles does not substantially narrow the urethral lumen and bladder outlet, and
 a cryogenic probe.

9. The apparatus of claim 8, wherein at least one of the plurality of needles is hollow, and wherein the cryogenic probe is configured to be longitudinally advanced through the hollow needle.

14

10. An apparatus for remodeling at least one treatment site within the lower urinary tract of a female patient, the lower urinary tract including a urethra having a urethral lumen and a bladder having a bladder outlet, the apparatus comprising:
 an elongated shaft having proximal and distal ends and a distal region disposed adjacent to the distal end;
 a handle coupled to the proximal end;
 a plurality of needles configured to selectively extend from within the shaft, the plurality of needles configured for treating a submucosal layer of the urethra or bladder outlet to cause a reduction in the compliance of the submucosal layer; and
 an expandable member deployable at a predetermined distance distal of the plurality of needles, the expandable member adapted to be deployed in the bladder and anchored against the bladder outlet,
 wherein the plurality of needles does not substantially narrow the urethral lumen and bladder outlet, and
 wherein a distance between the means for treating and the expandable member may be longitudinally adjusted.

11. The apparatus of claim 10, wherein the expandable member is disposed on a shaft, the apparatus further comprising a threaded interface between the shaft and a central lumen of the elongated shaft.

12. The apparatus of claim 10, wherein the expandable member is disposed on a shaft, the apparatus further comprising an actuator coupled to the shaft.

* * * * *