

US007302168B2

(12) **United States Patent**
Nonomura et al.

(10) **Patent No.:** **US 7,302,168 B2**
(45) **Date of Patent:** ***Nov. 27, 2007**

(54) **OPTICAL DISK, REPRODUCTION APPARATUS, REPRODUCTION METHOD, AND RECORDING MEDIUM**

(75) Inventors: **Tomoyuki Nonomura**, Osaka (JP); **Masaya Yamamoto**, Osaka (JP); **Yoshihiro Mori**, Osaka (JP); **Yasushi Uesaka**, Hyogo (JP); **Masayuki Kozuka**, Arcadia, CA (US)

(73) Assignee: **Matsushita Electric Industrial Co., Ltd.**, Kadoma (JP)

(*) Notice: Subject to any disclaimer, the term of this patent is extended or adjusted under 35 U.S.C. 154(b) by 0 days.

This patent is subject to a terminal disclaimer.

(21) Appl. No.: **11/428,492**

(22) Filed: **Jul. 3, 2006**

(65) **Prior Publication Data**

US 2006/0239662 A1 Oct. 26, 2006

Related U.S. Application Data

(60) Continuation of application No. 11/124,539, filed on May 6, 2005, which is a division of application No. 10/338,060, filed on Jan. 7, 2003, now Pat. No. 6,907,188, which is a continuation of application No. 09/525,336, filed on Mar. 10, 2000, now Pat. No. 6,574,419.

(30) **Foreign Application Priority Data**

Mar. 12, 1999 (JP) 11-067559

(51) **Int. Cl.**

H04N 5/91 (2006.01)

(52) **U.S. Cl.** 386/95; 386/126

(58) **Field of Classification Search** 386/46, 386/95, 96, 104, 105, 106, 121, 125, 126
See application file for complete search history.

(56) **References Cited**

U.S. PATENT DOCUMENTS

4,794,465 A	12/1988	Van Luyt et al.
5,555,098 A	9/1996	Parulski
5,630,006 A	5/1997	Hirayama et al.
5,684,804 A	11/1997	Baronetti et al.
5,687,160 A	11/1997	Aotake et al.
5,870,523 A	2/1999	Kikuchi et al.
5,875,303 A	2/1999	Huizer et al.
5,966,352 A	10/1999	Sawabe et al.
6,067,400 A	5/2000	Saeki
6,122,436 A	9/2000	Okada et al.

(Continued)

FOREIGN PATENT DOCUMENTS

CN 1173698 A 3/1997

(Continued)

Primary Examiner—Huy Nguyen

(74) *Attorney, Agent, or Firm*—Renner, Otto, Boisselle & Sklar, LLP

(57) **ABSTRACT**

An optical disk includes an audio data storage area for storing audio data; a still picture data storage area for storing a plurality of pieces of still picture data; and a management area for storing reproduction control information for controlling reproduction of the audio data and the plurality of pieces of still picture data. The reproduction control information has flag information representing specified still picture data among the plurality of pieces of still picture data.

10 Claims, 31 Drawing Sheets

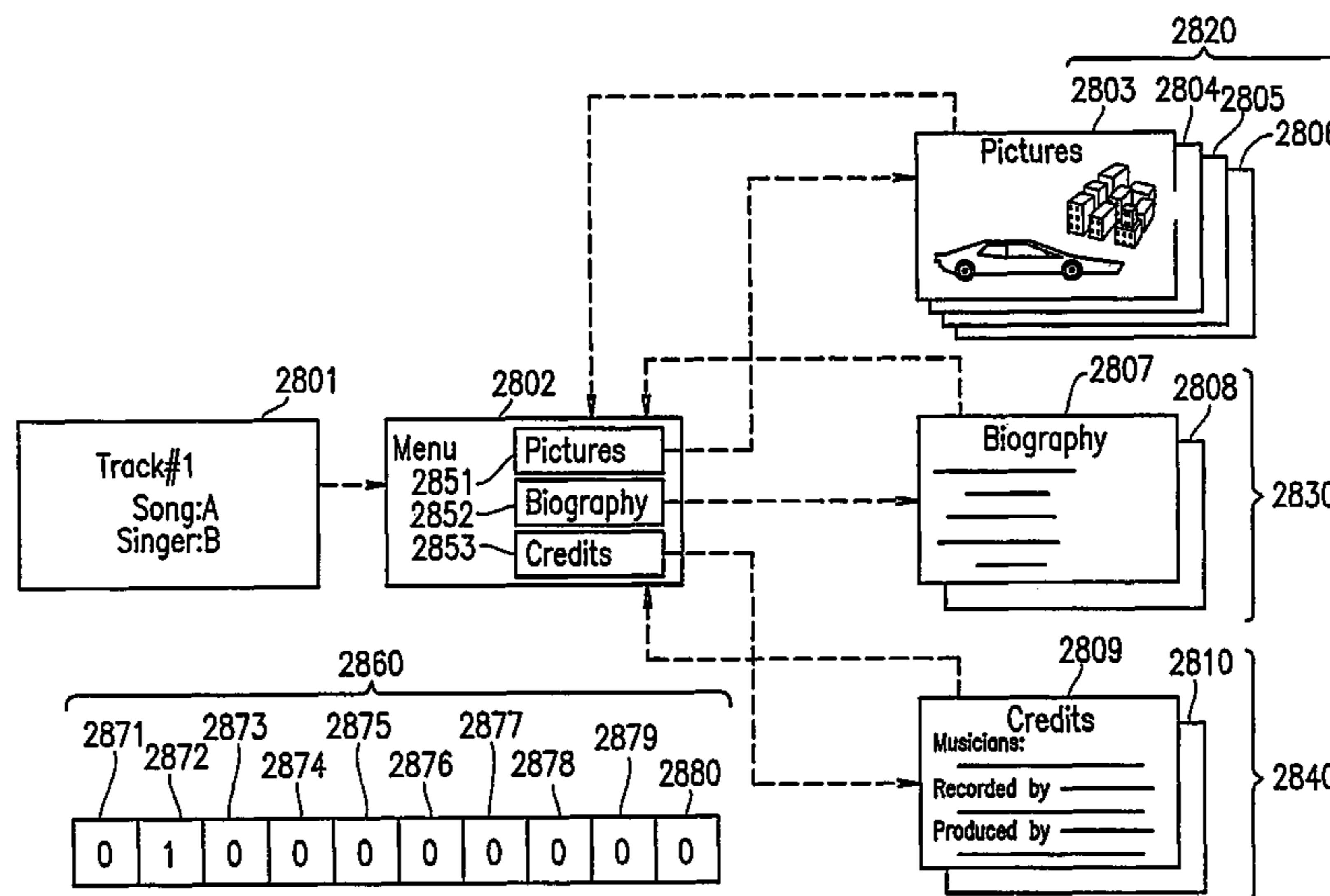

US 7,302,168 B2

Page 2

U.S. PATENT DOCUMENTS					
			EP	0 942 609	3/1999
			EP	0 951 021	4/1999
6,157,769	A	12/2000	JP	11-331780	11/1999
6,526,223	B1	2/2003	KR	2001-0022703	3/2001
6,574,419	B1	6/2003	KR	2001-0022704	3/2001
6,907,188	B2 *	6/2005	WO	94/14159	7/1993
			WO	99/08281	2/1999
			WO	99/08282	2/1999
FOREIGN PATENT DOCUMENTS					
EP	0 757 350	8/1996			
EP	0 892 404	7/1998			
EP	0 910 082	10/1998			

* cited by examiner

FIG. 1A

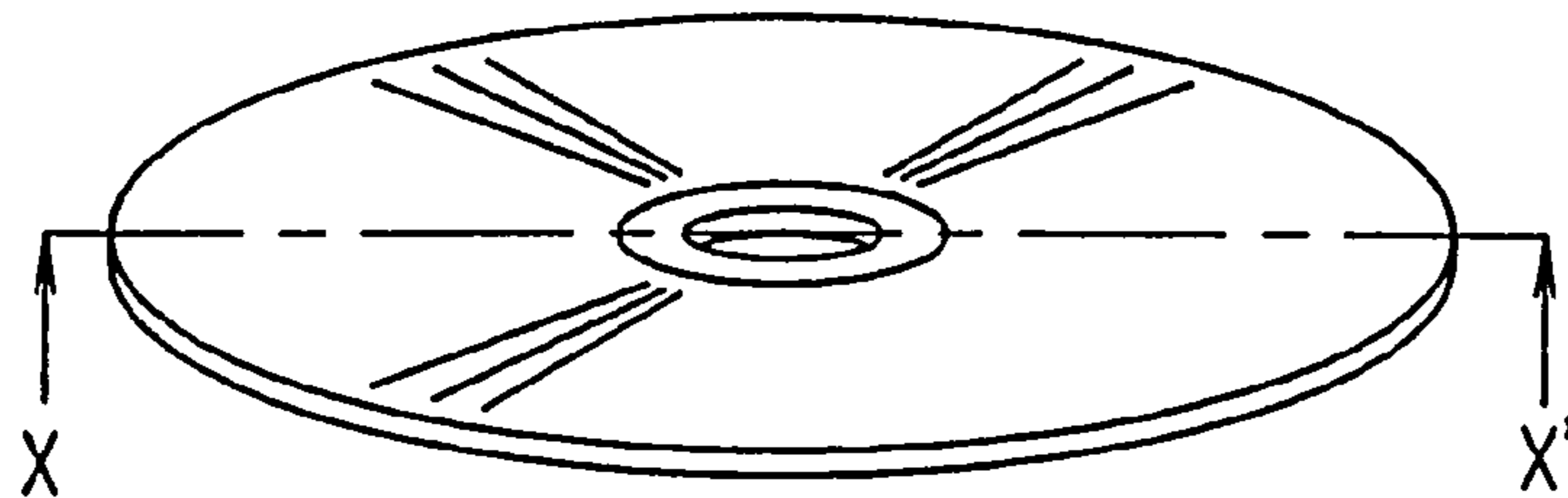

FIG. 1B

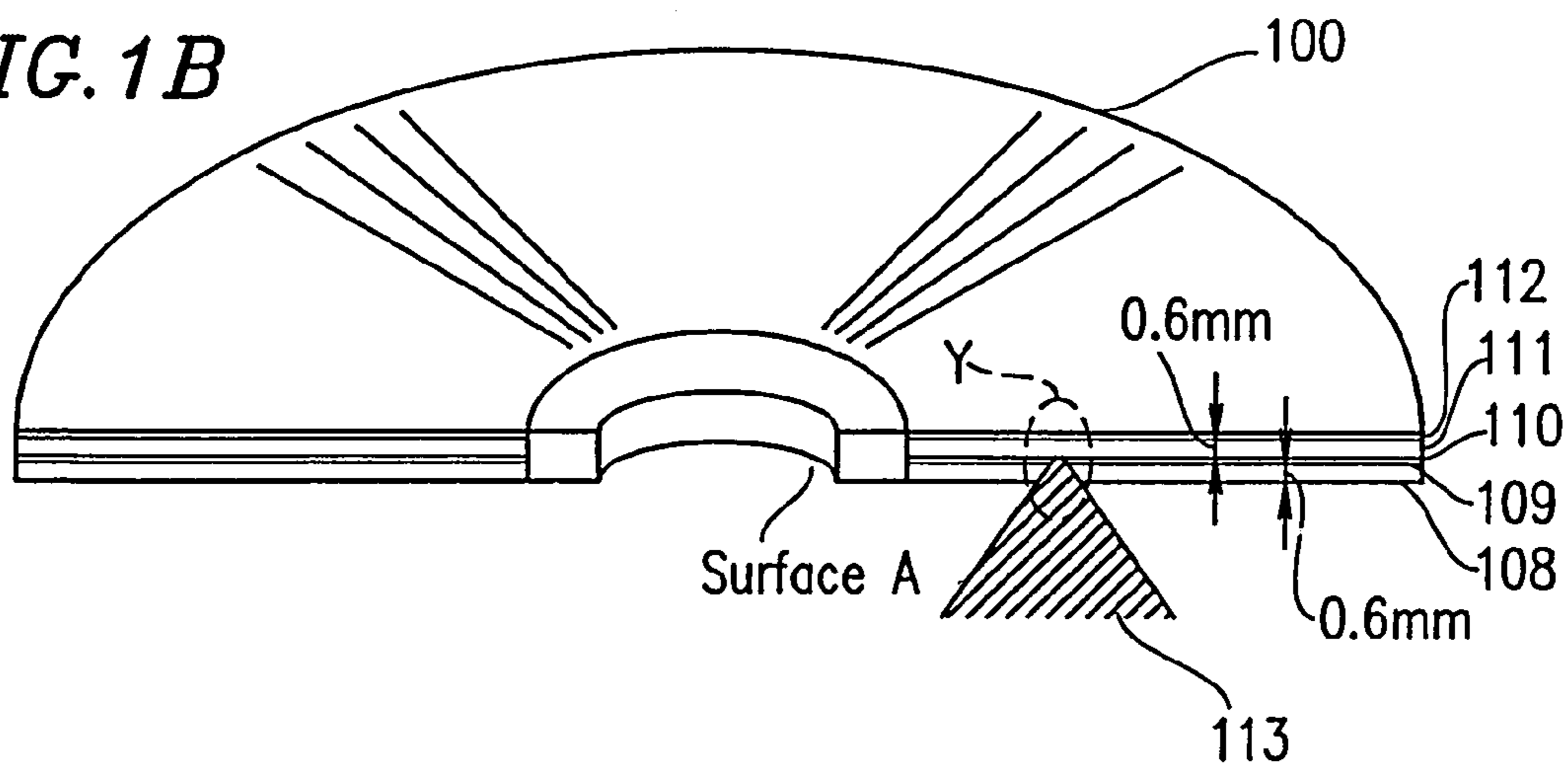

FIG. 1C

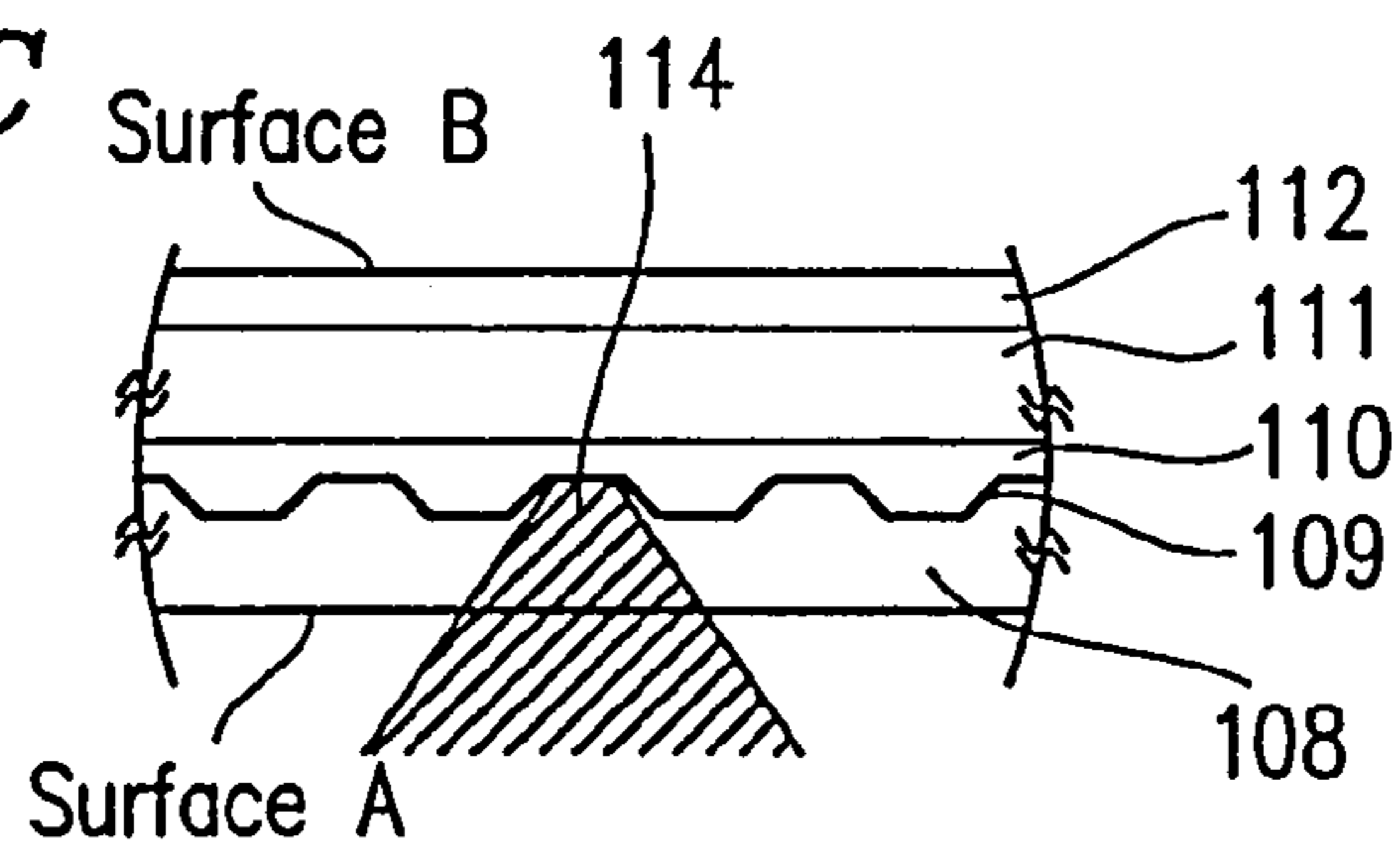

FIG. 1D

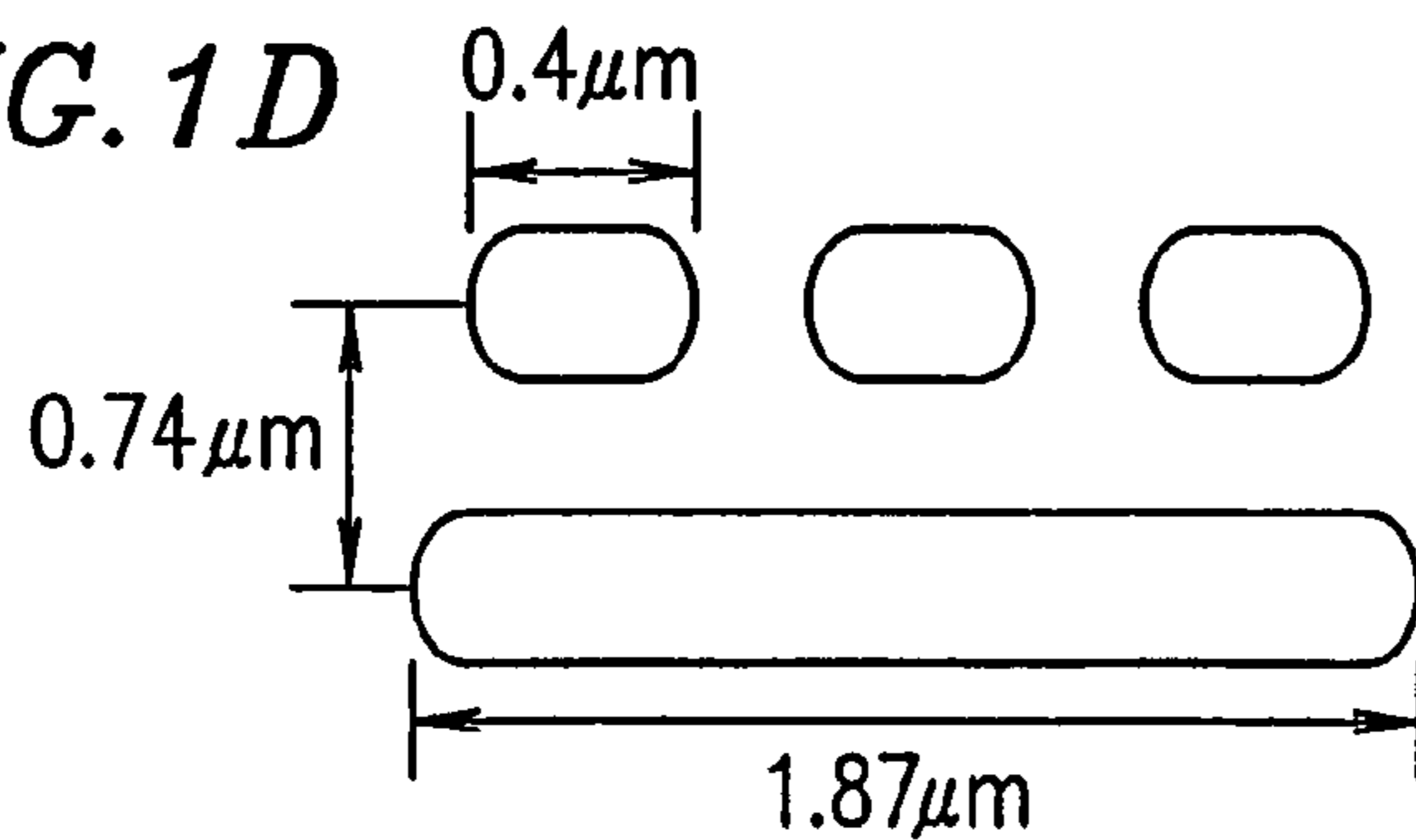

FIG. 2A

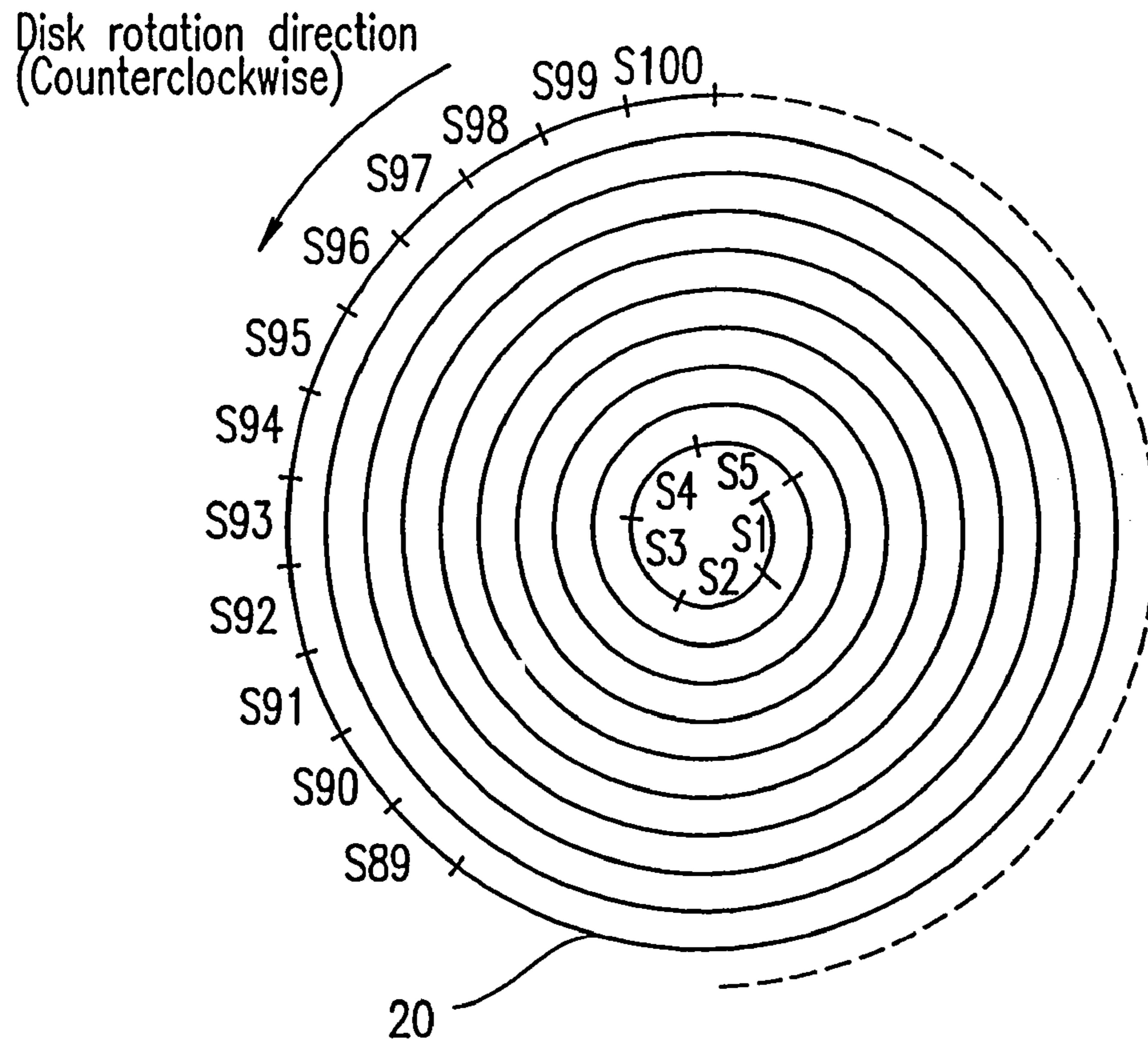
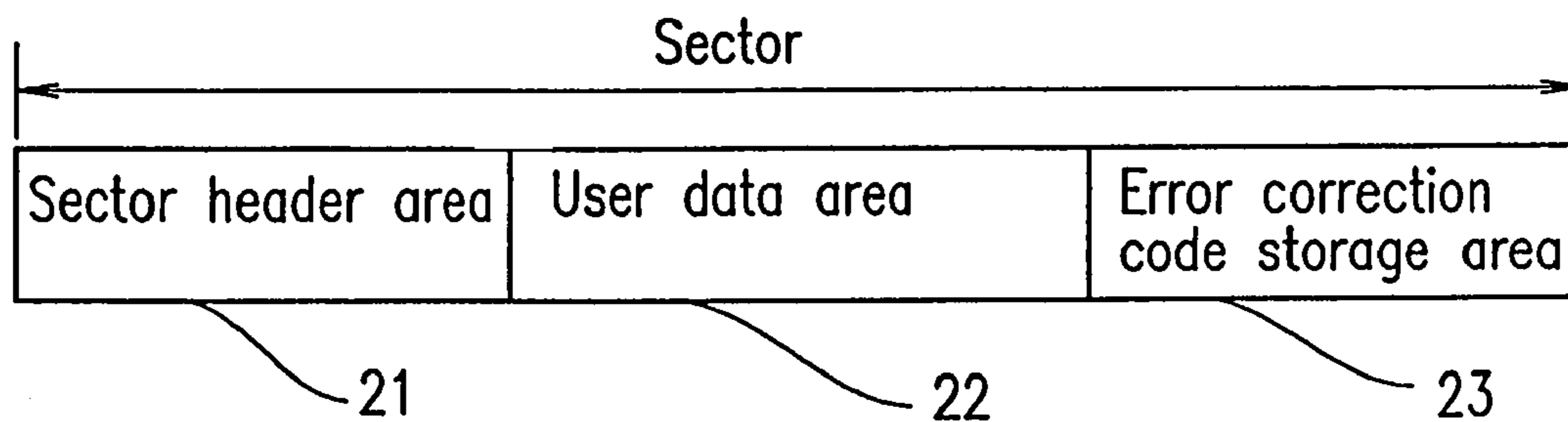

FIG. 2B



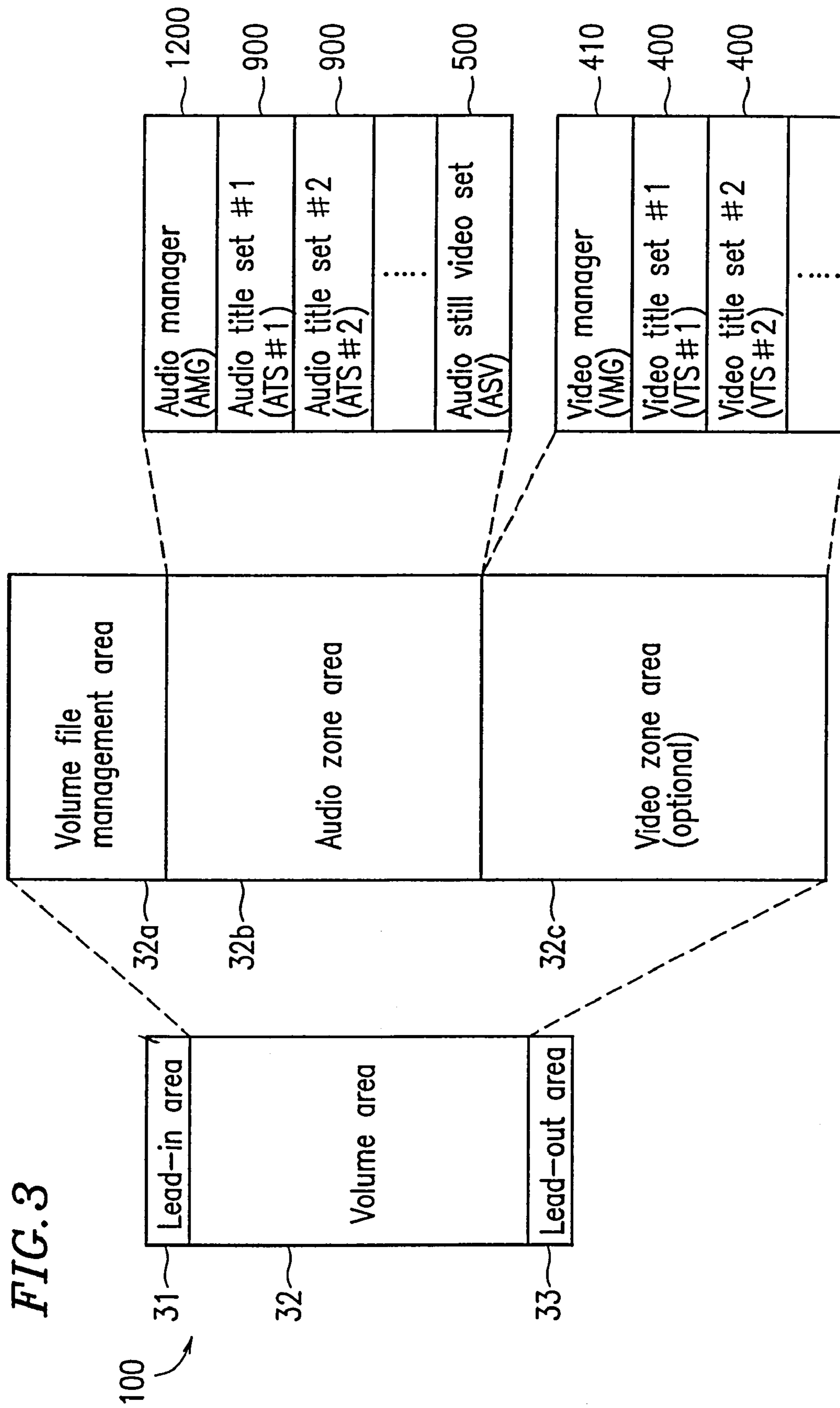

FIG. 4

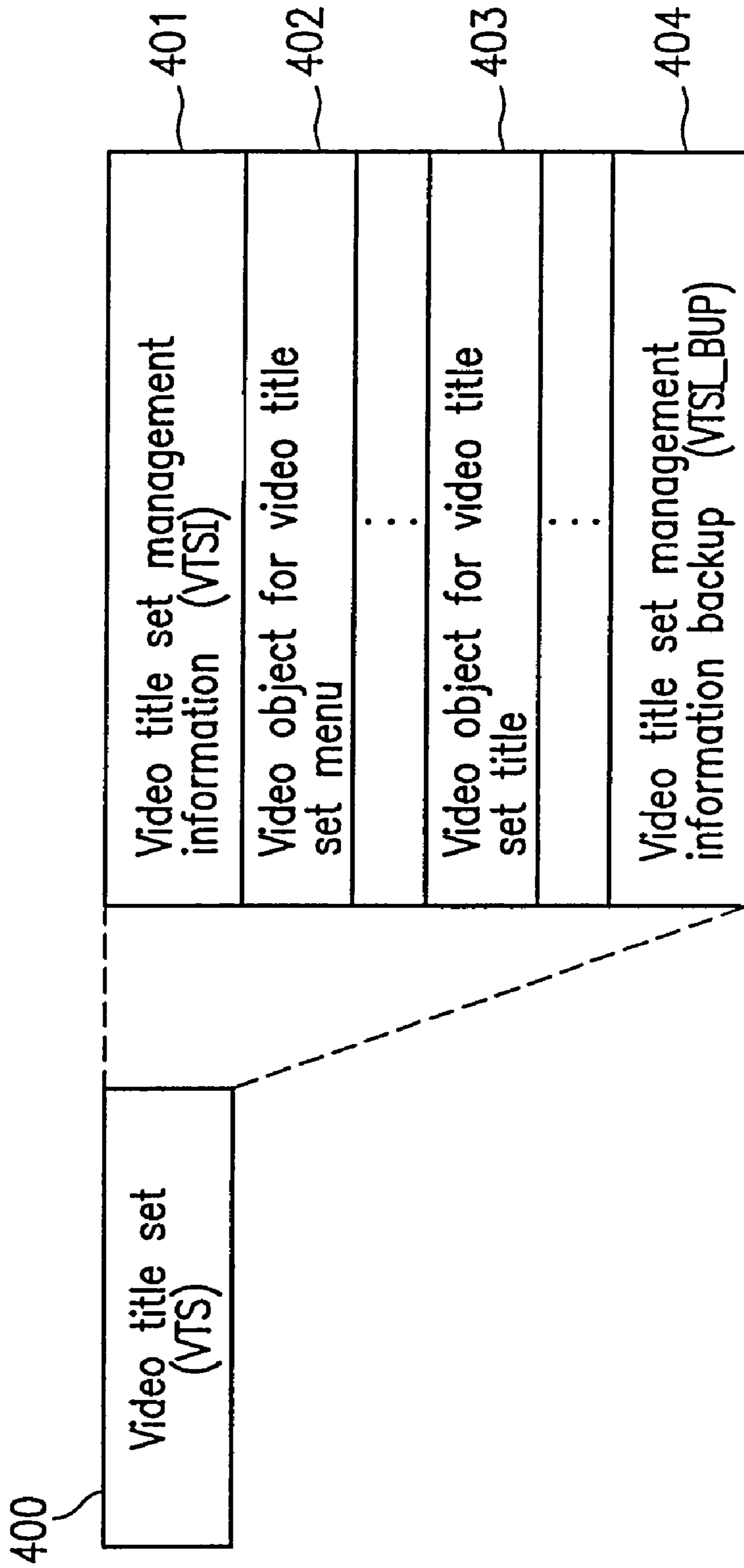

FIG. 5

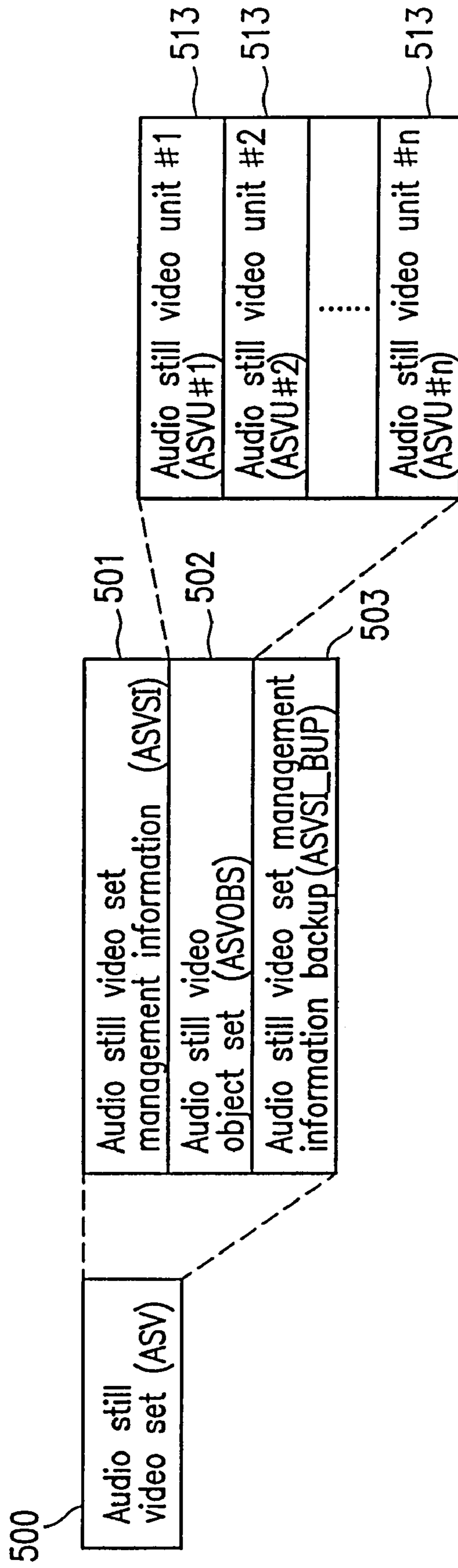

FIG. 6A

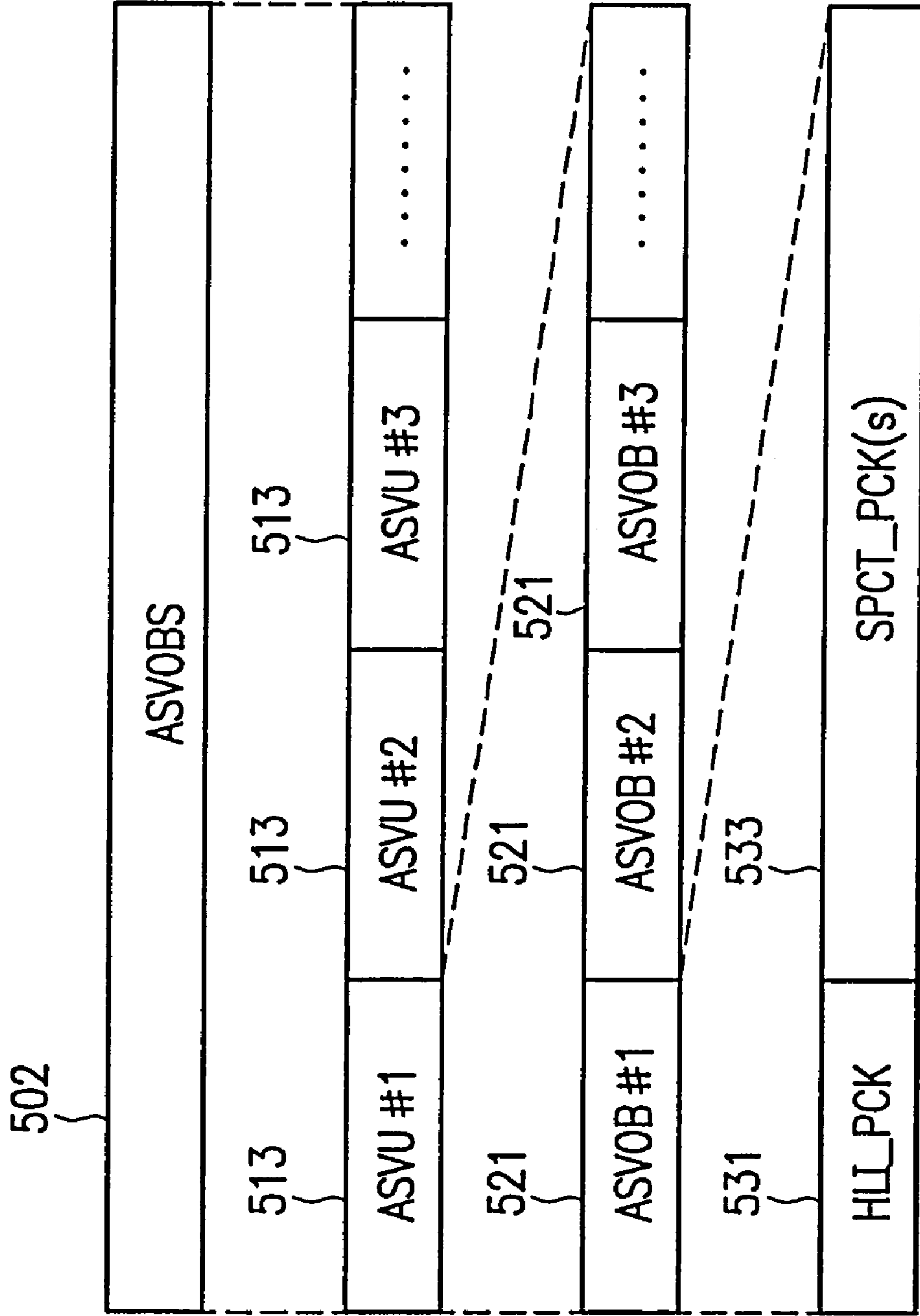

FIG. 6B

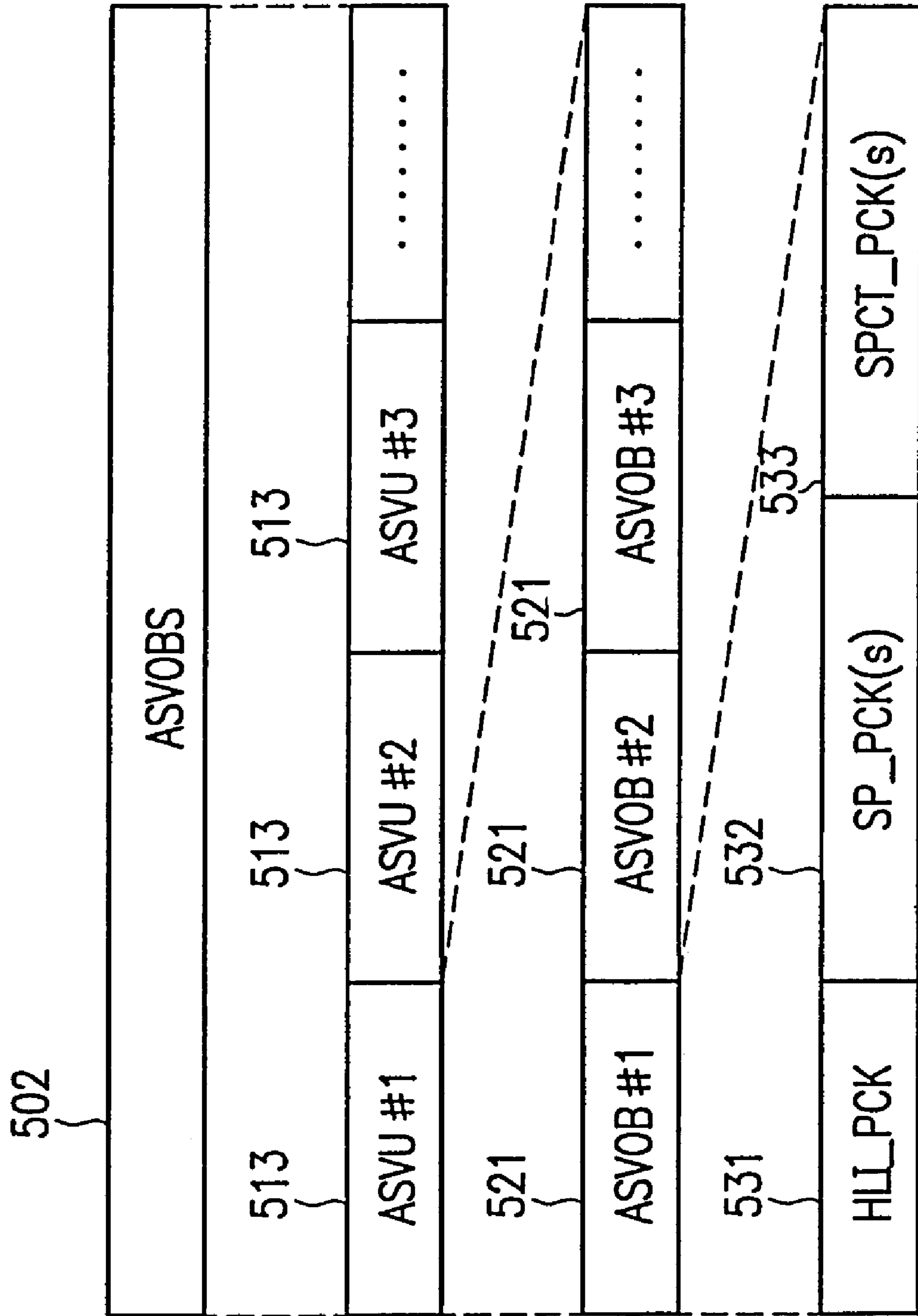
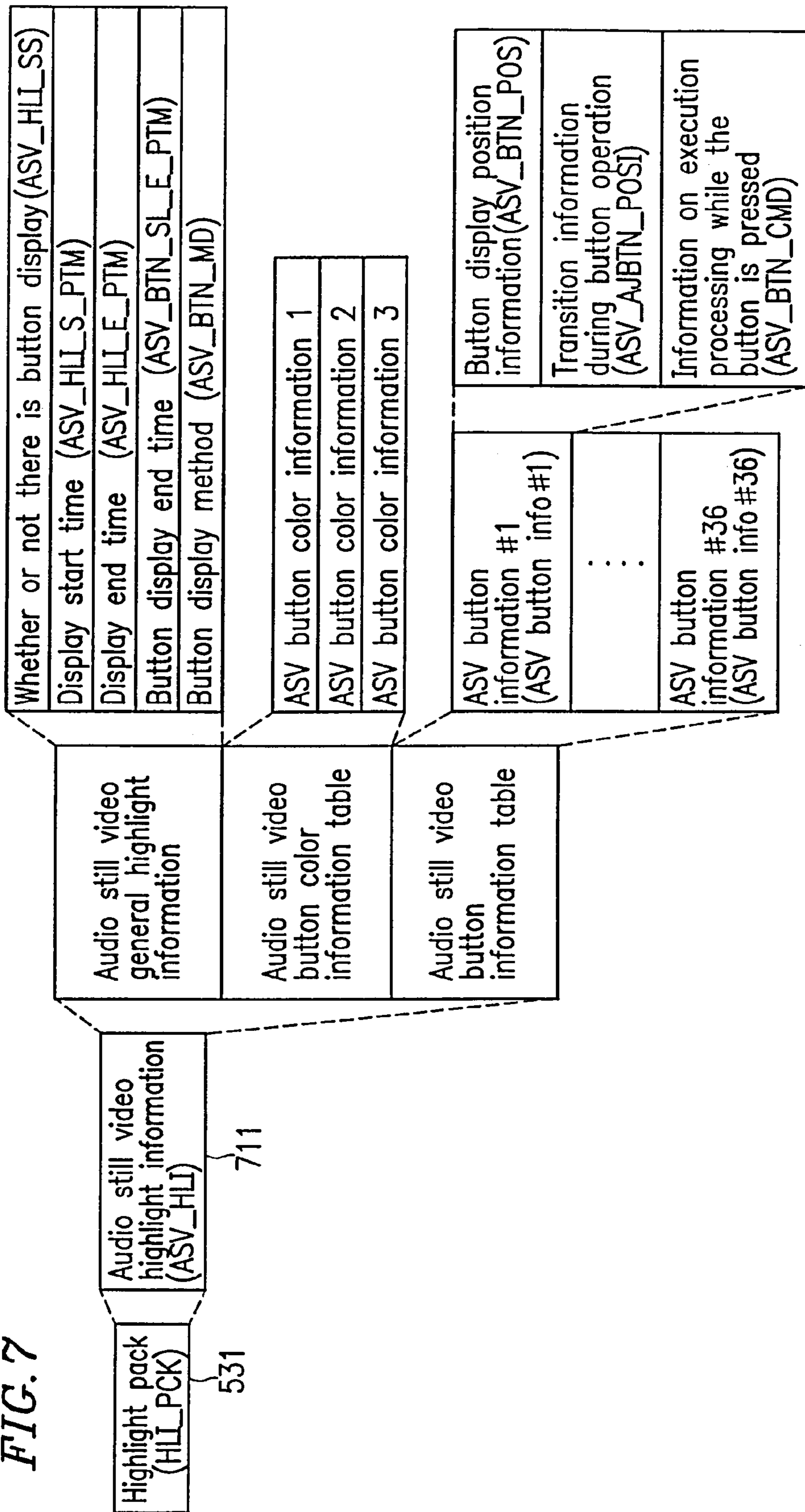
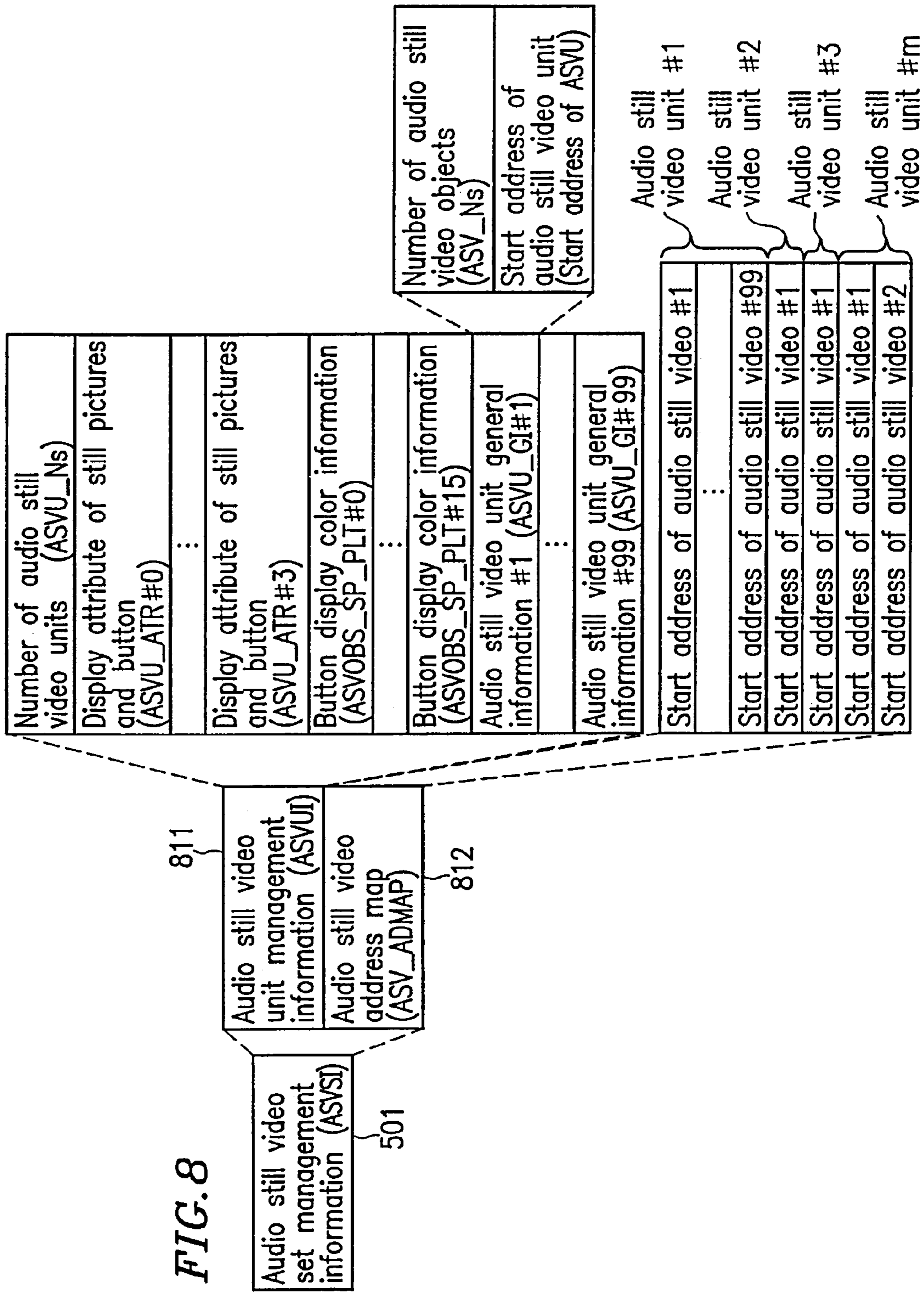

FIG. 7





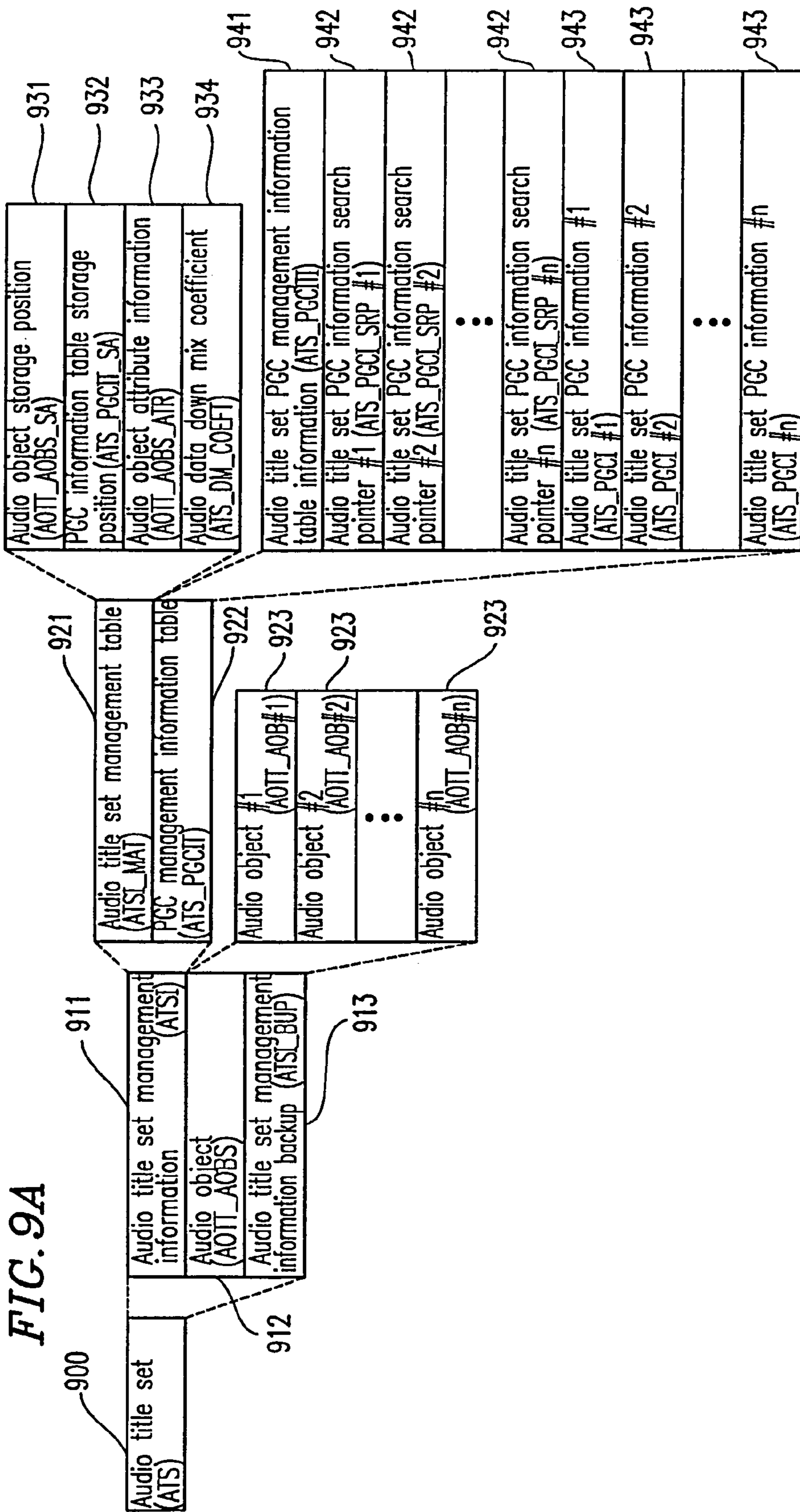
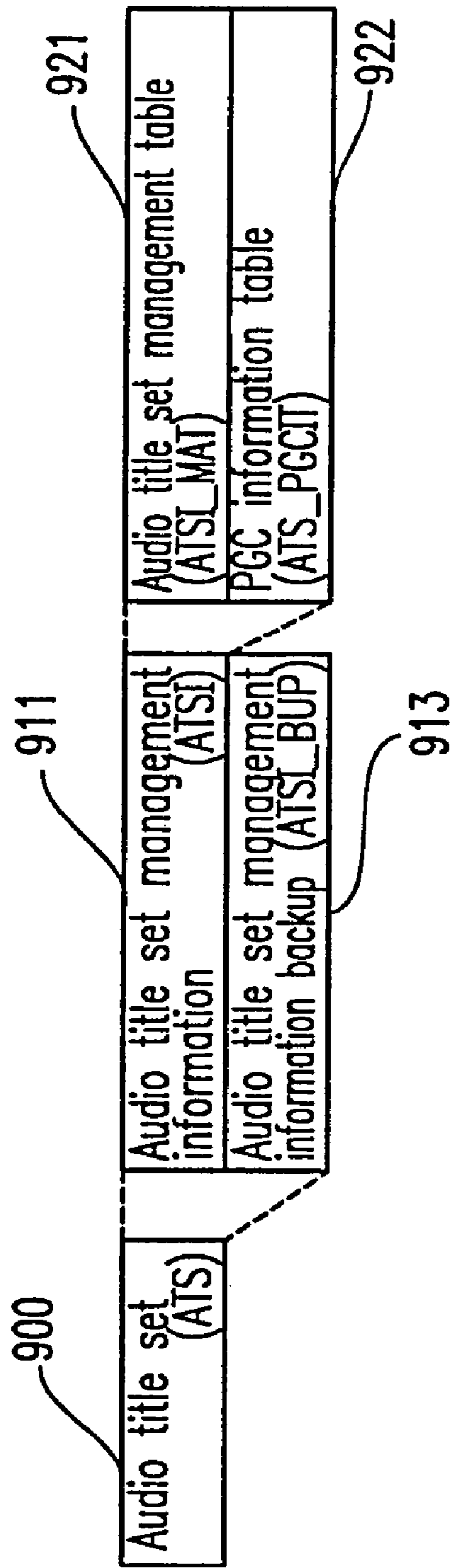

FIG. 9B



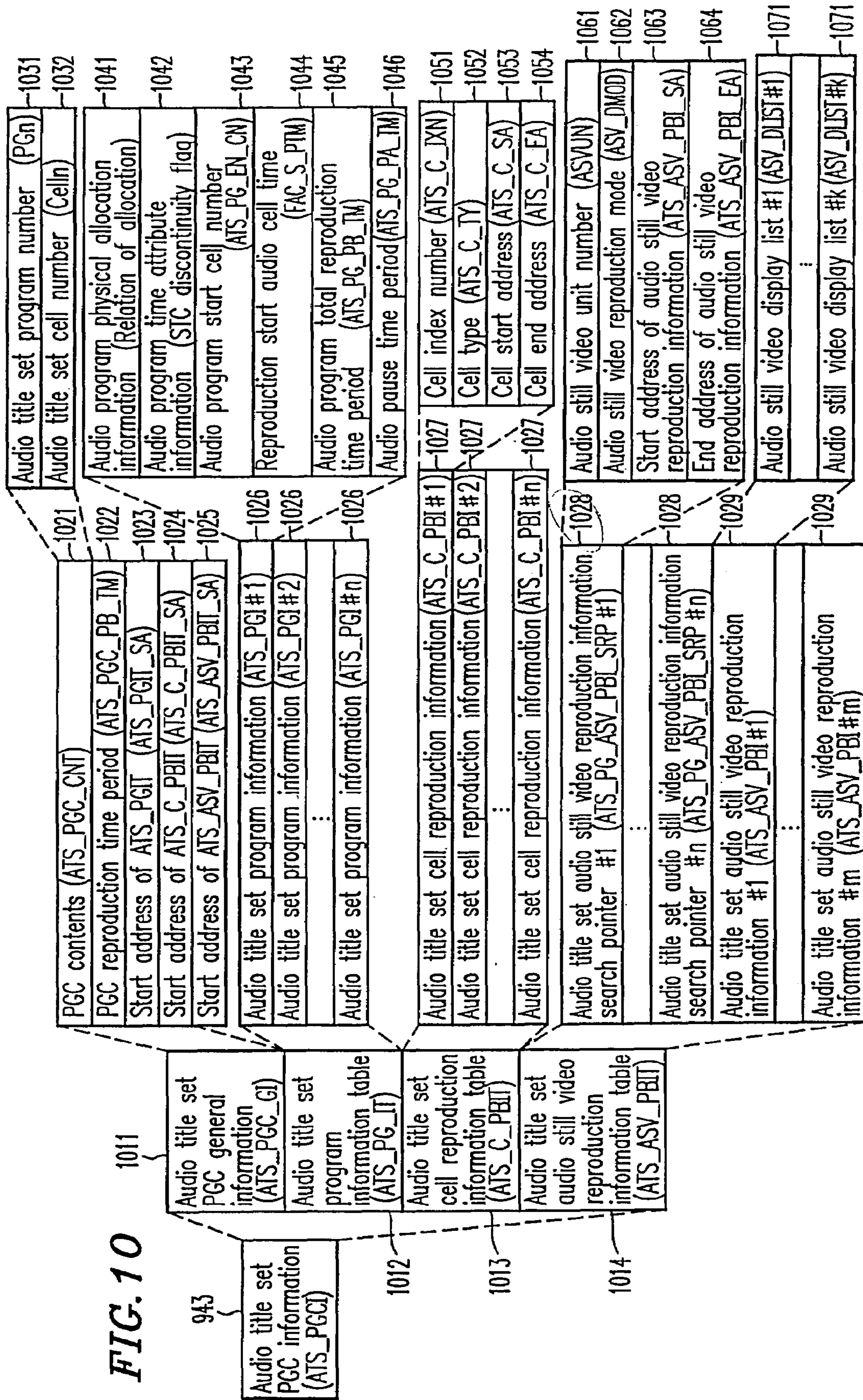

FIG. 11A

ASV number	1101
Specified video stream existence flag (Entry DLIST flag)	1102
FOSL BTNN:Forcedly selected button number	1103
Program number	1104
Display timing information	1105
Start effect mode	1106
End effect mode	1107
Start effect period	1108
End effect period	1109

FIG. 11B

Reserved	
Specified video stream existence flag (Entry DLIST flag)	1102
FOSL BTNN:Forcedly selected button number	1103
Program number	1104
Display timing information	1105
Start effect mode	1106
End effect mode	1107
Start effect period	1108
End effect period	1109

FIG. 11C

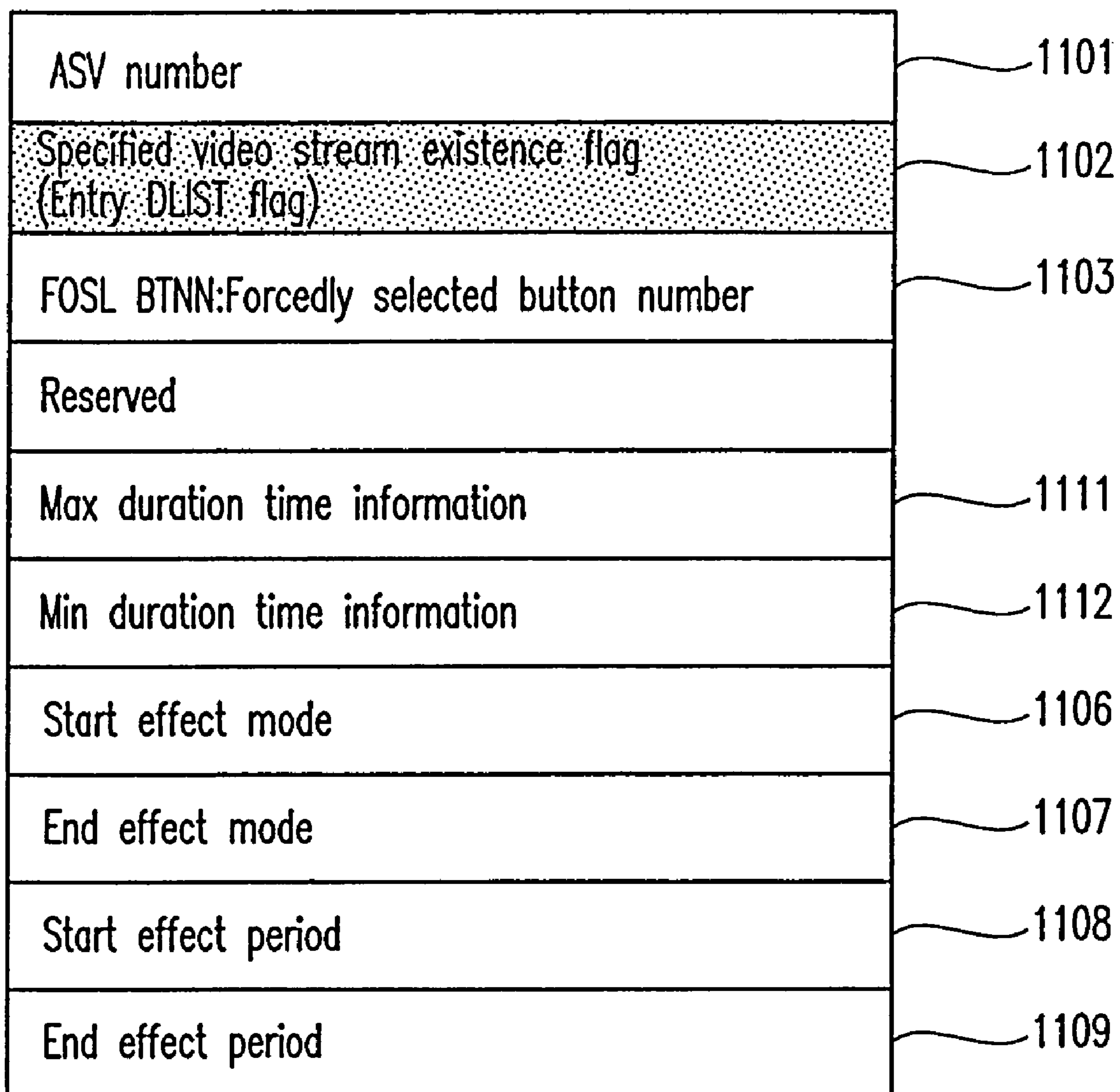
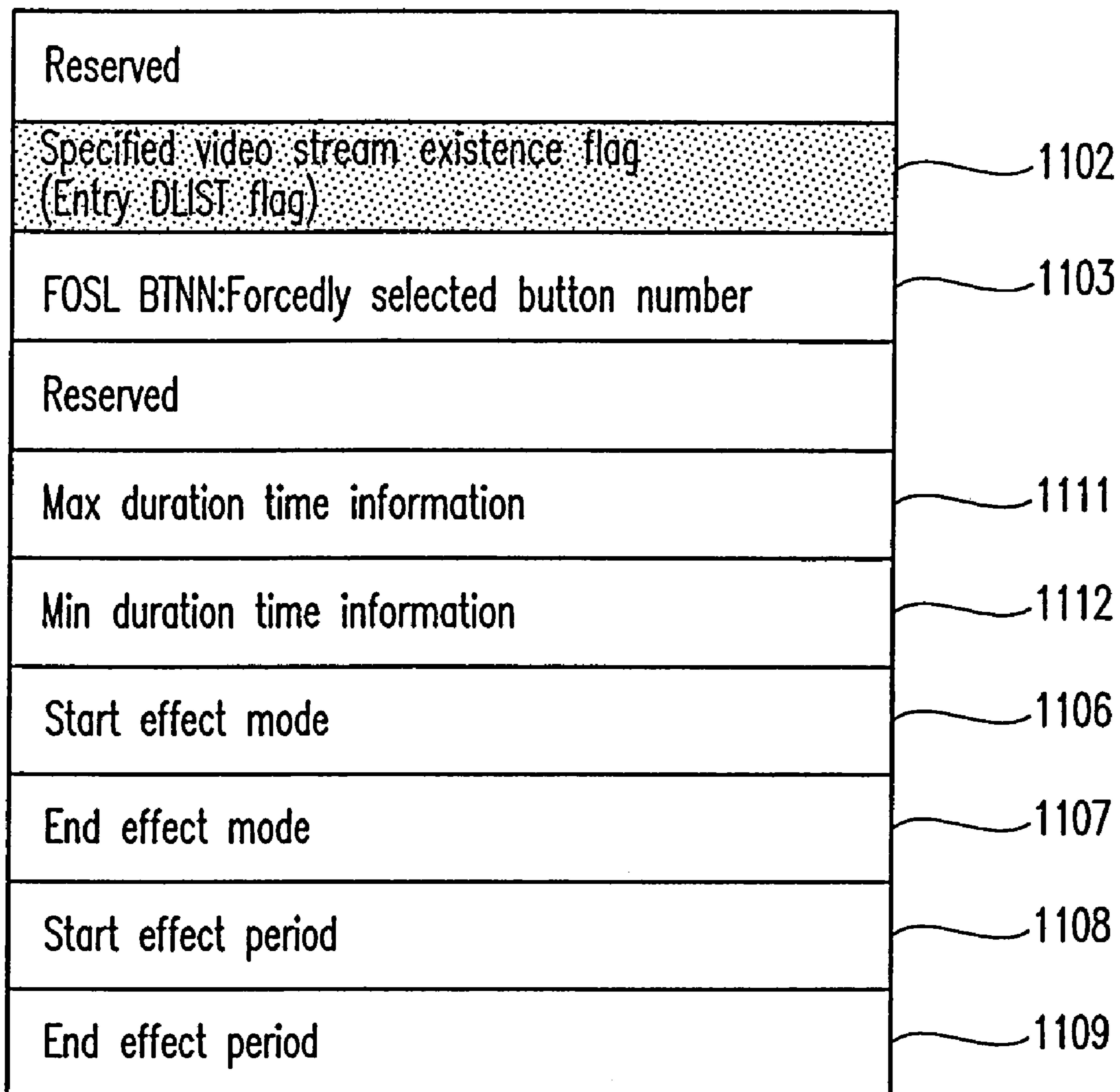

FIG. 11D



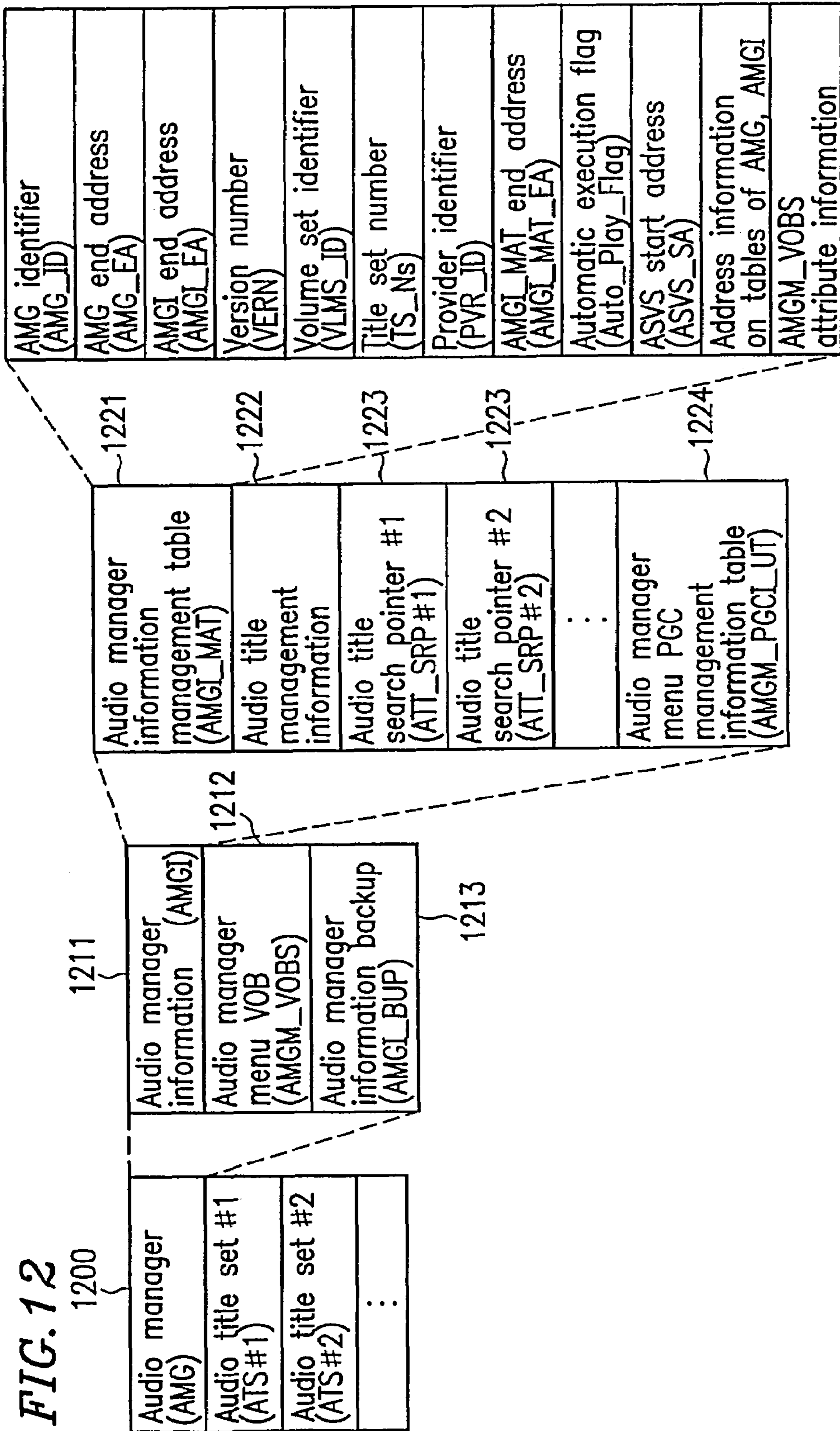

FIG. 13

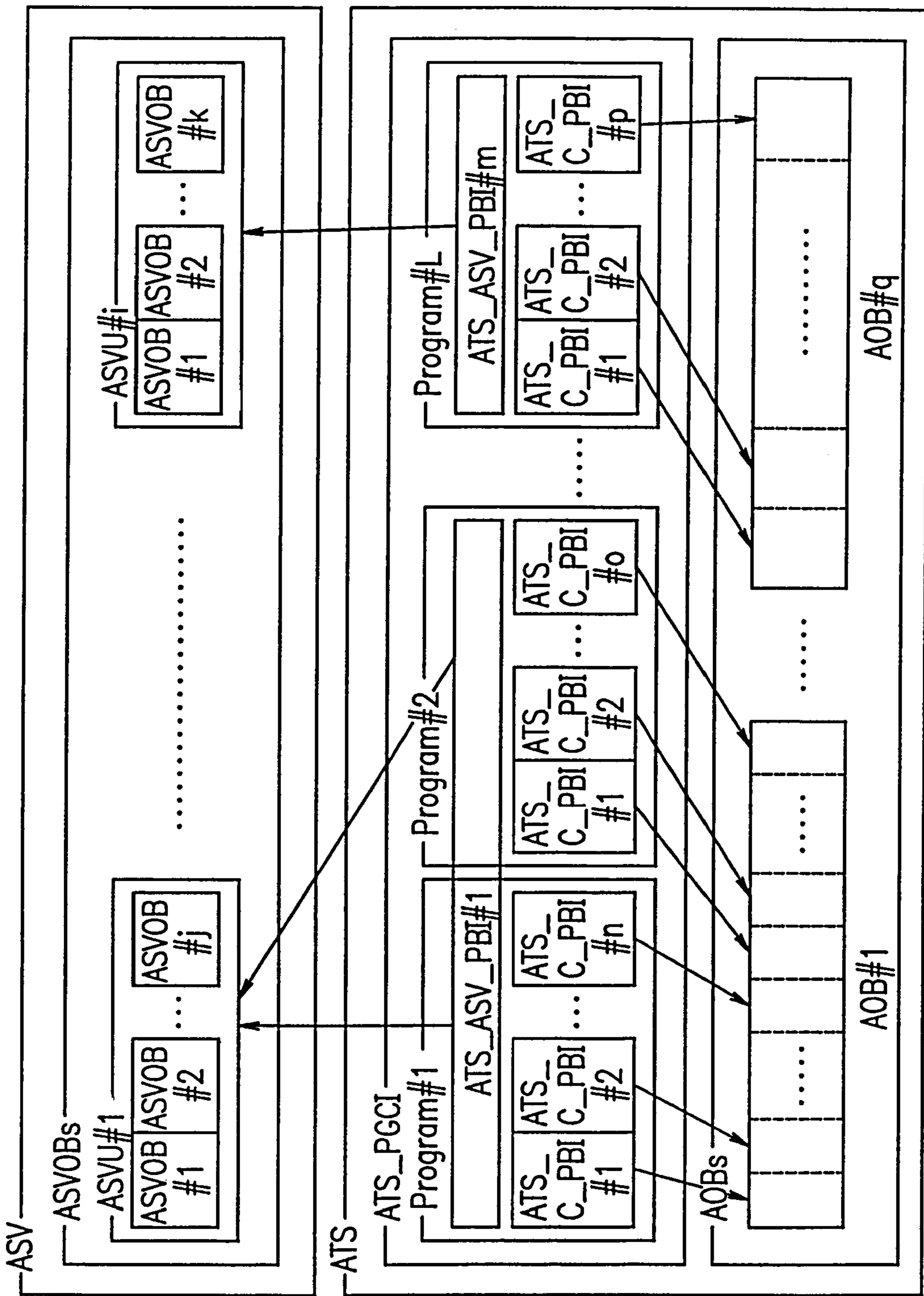

FIG. 14

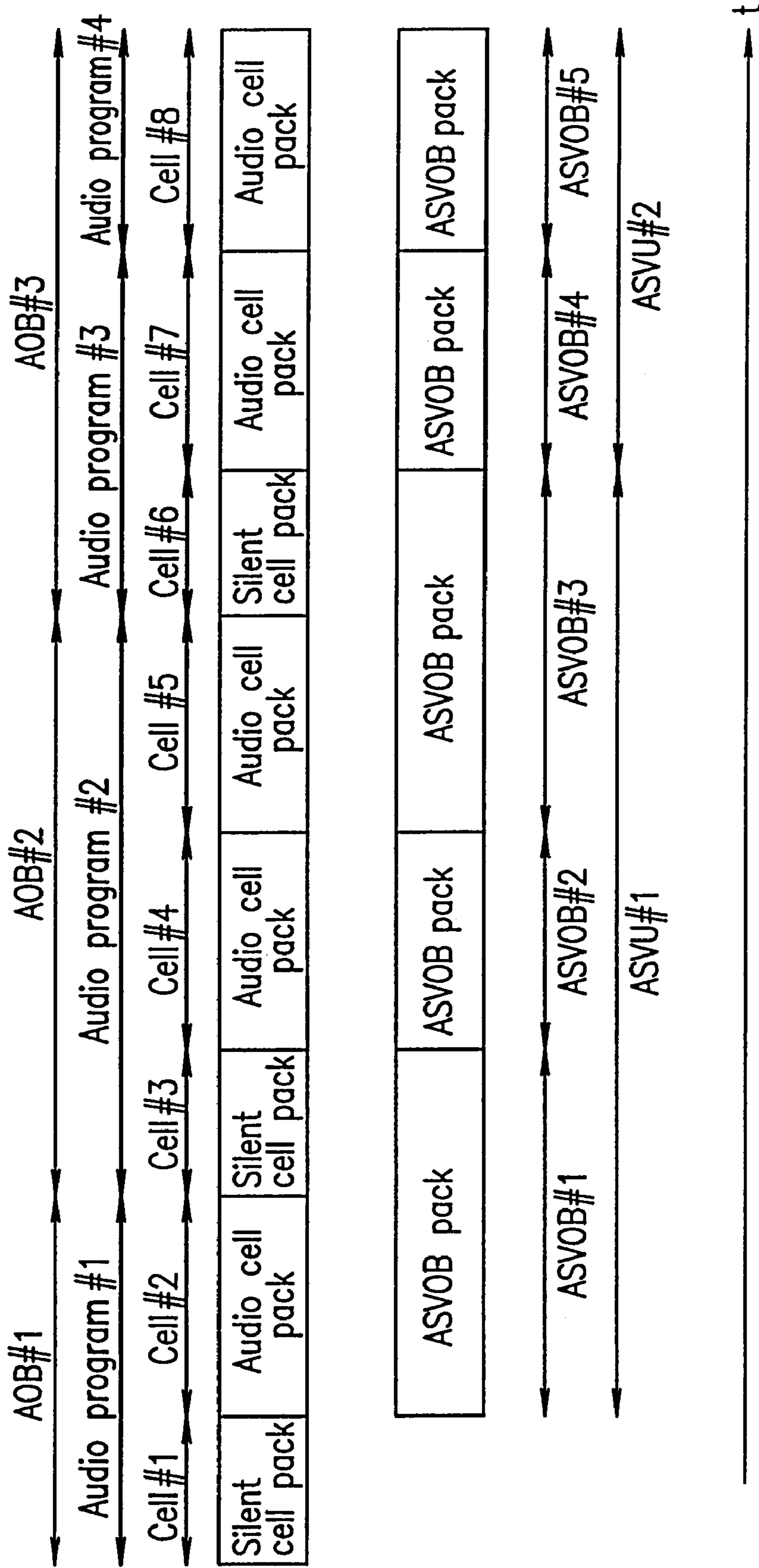

FIG. 15

	1041	1042	1043	1044	1045	1046	1061	1062	1063	1064
	Physical allocation information	Time attribute information	Start cell number	Reproduction start audio cell time	Audio program total reproduction time period	Audio pause time period	ASVU number	ASV reproduction mode	ATS_ASV_PBI start address	ATS_ASV_PBI end address
Audio program #1	No-Continue	No-Continue	1	90,000	5,490,000	90,000	1	SlideShow	(Leading address of #1)	(Final address of #1)
Audio program #2	Continue	No-Continue	3	90,000	10,890,000	90,000	1	SlideShow	(Leading address of #1)	(Final address of #1)
Audio program #3	No-Continue	No-Continue	6	90,000	5,490,000	90,000	2	Browsable	(Leading address of #2)	(Final address of #2)
Audio program #4	Continue	Continue	8	5,490,000	5,400,000	0	2	Browsable	(Leading address of #2)	(Final address of #2)

FIG. 16A

	1101	1102	1103	1104	1105	1106	1108	1107	1109
	ASV number	Specified video stream existence flag	Forcedly selected button number	Audio program number	Display timing information	Start effect mode	Start effect duration	End effect mode	End effect duration
ATS_ASV_PBI#1	1	1	1	1	90,000	1	352	1	352
Display list #1	1	1	1	1	90,000	1	352	1	352
Display list #2	2	0	2	2	90,000	1	352	1	352
Display list #3	3	0	3	2	5,580,000	1	352	2	352

1071 ~
 1029 {
 1071 ~
 1071 ~

FIG. 16B

	1101	1102	1103	1104	1111	1112	1106	1108	1107	1109
	ASV number	Specified video stream existence flag	Forcedly selected button number	Audio program number	Maximum display time information	Minimum display time information	Start effect mode	Start effect duration	End effect mode	End effect duration
1029 { 1071 ~	4	0	4	3	5,490,000	5,490,000	2	352	2	352
1071 ~	5	0	5	4	5,490,000	5,490,000	2	352	2	352

ATS_ASV_PBI#2

FIG. 17

1027

1051 1052 1053 1054

	Cell index number	Cell type	Cell start address	Cell end address
Cell #1	0	Silent	0	95
Cell #2	1	Audio	96	14,975
Cell #3	0	Silent	14,976	15,071
Cell #4	1	Audio	15,072	20,831
Cell #5	2	Audio	20,832	26,591
Cell #6	0	Silent	26,592	26,687
Cell #7	1	Audio	26,688	41,567
Cell #8	2	Audio	41,568	56,443

FIG. 18

	ASV start address
ATS_PG_ASV_PBI #1	0
ATS_PG_ASV_PBI #2	50
ATS_PG_ASV_PBI #3	100
ATS_PG_ASV_PBI #4	150
ATS_PG_ASV_PBI #5	200

FIG. 19

	ASVOB number	Start ASVOB number
ASVU_GI #1	3	1
ASVU_GI #2	2	4

FIG. 20A

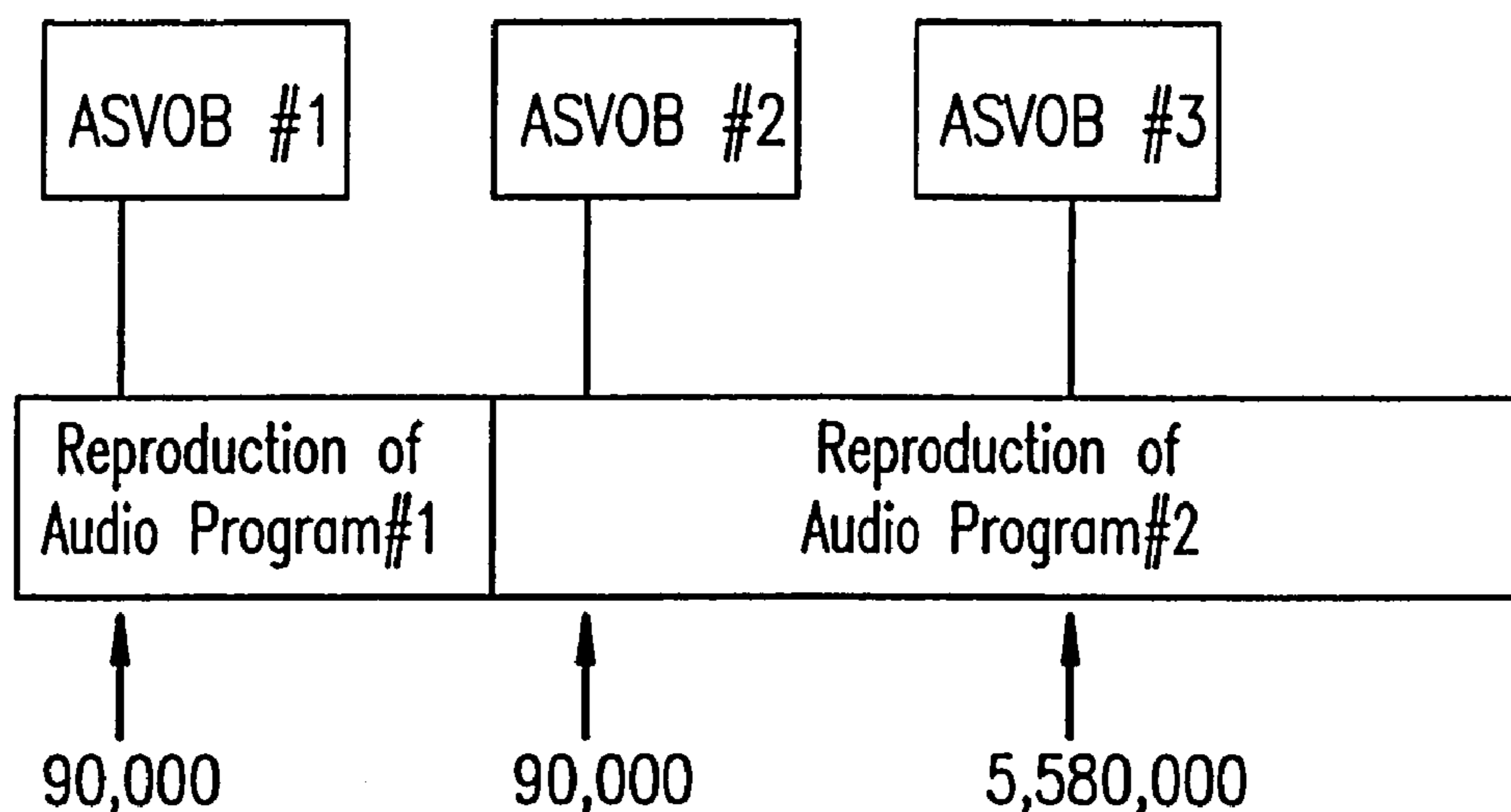
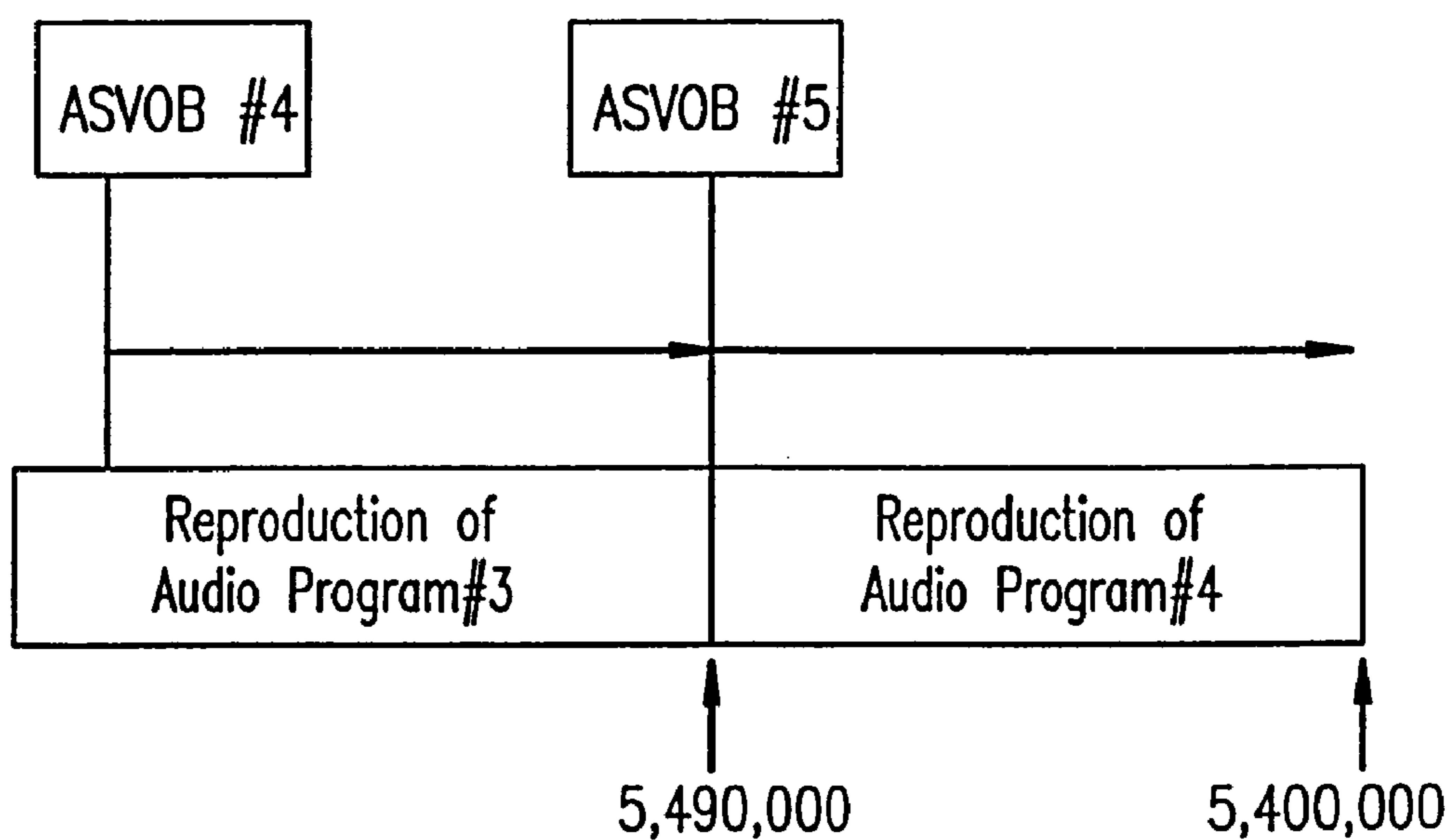

FIG. 20B



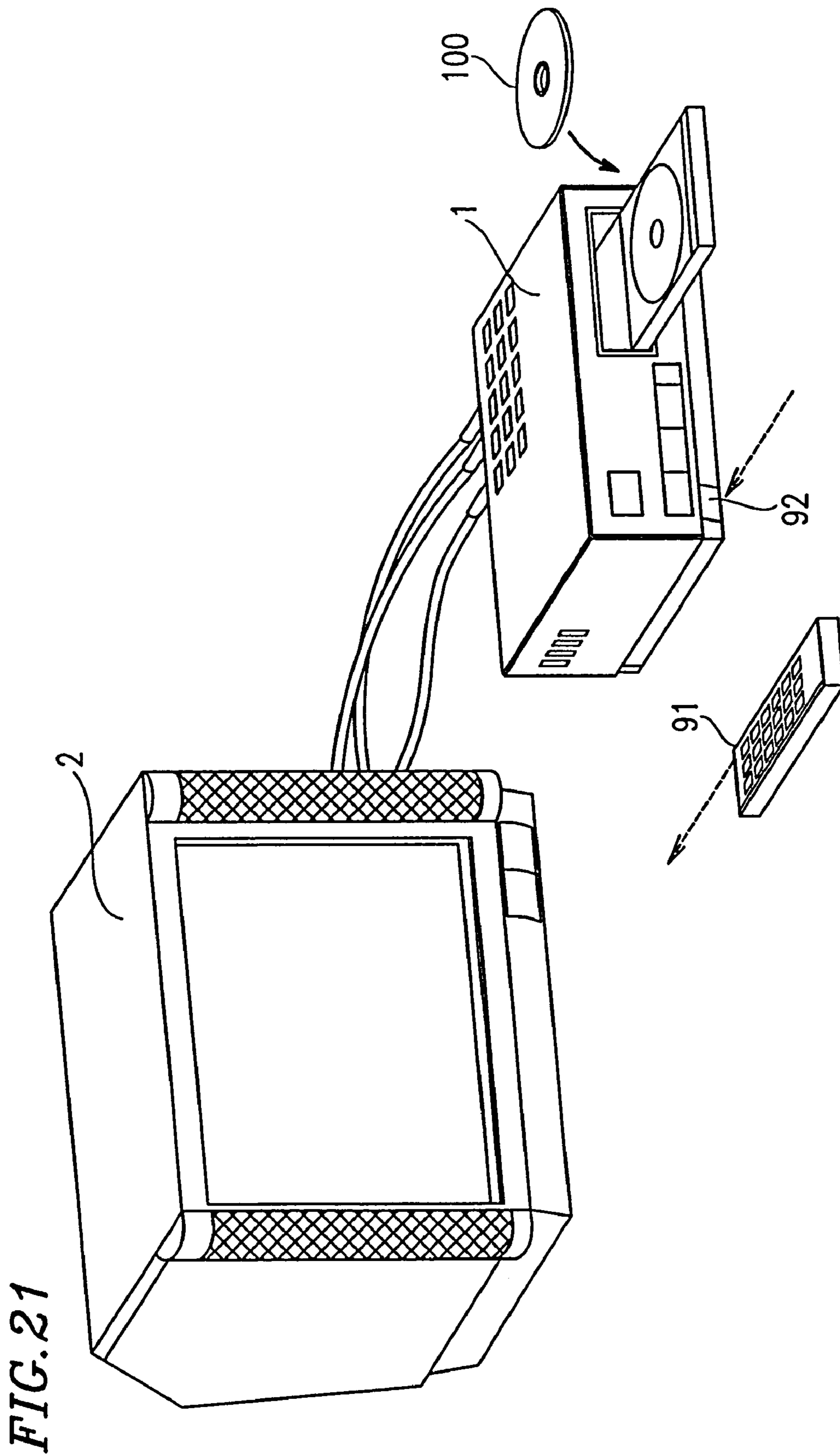
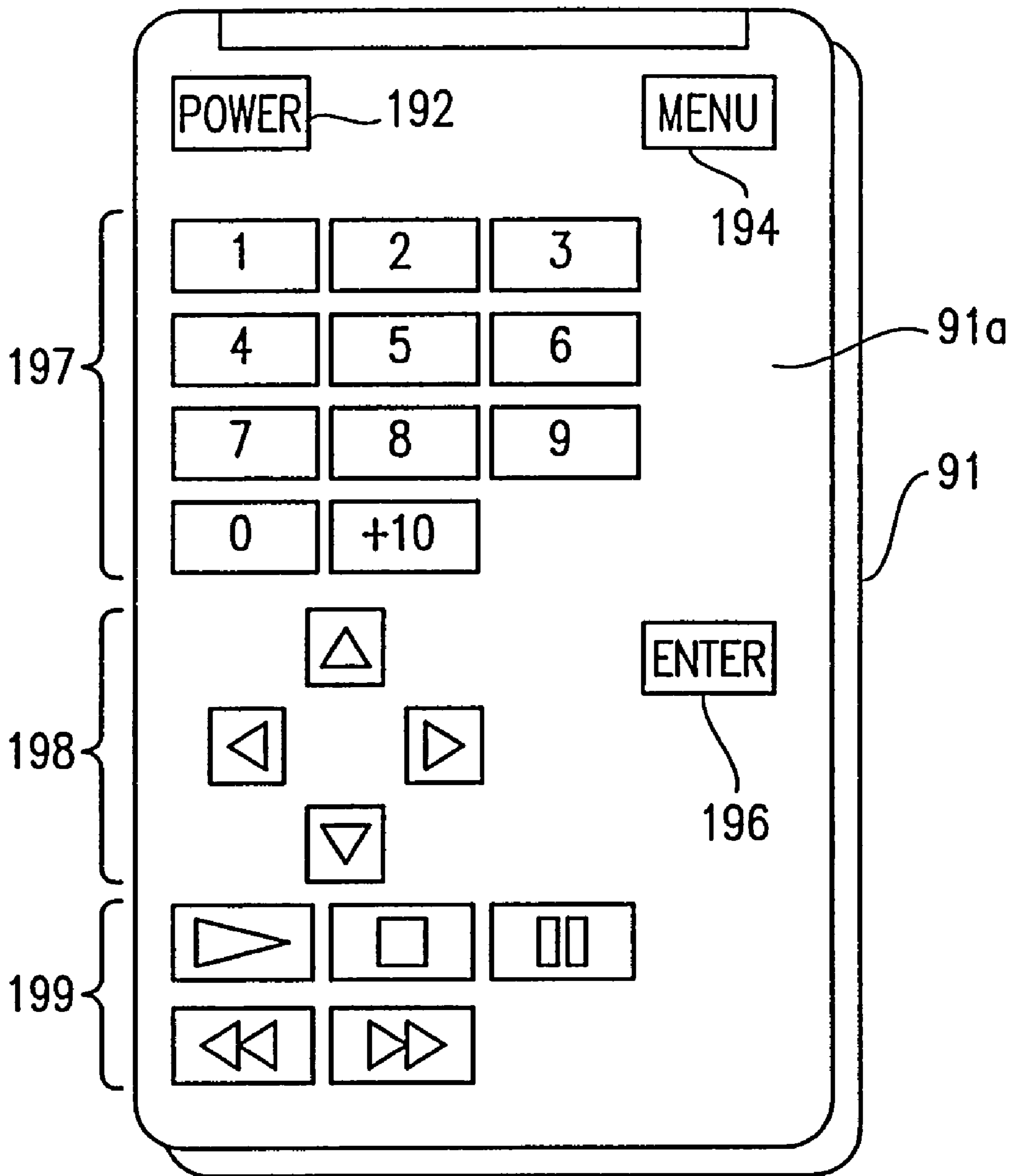

FIG. 22



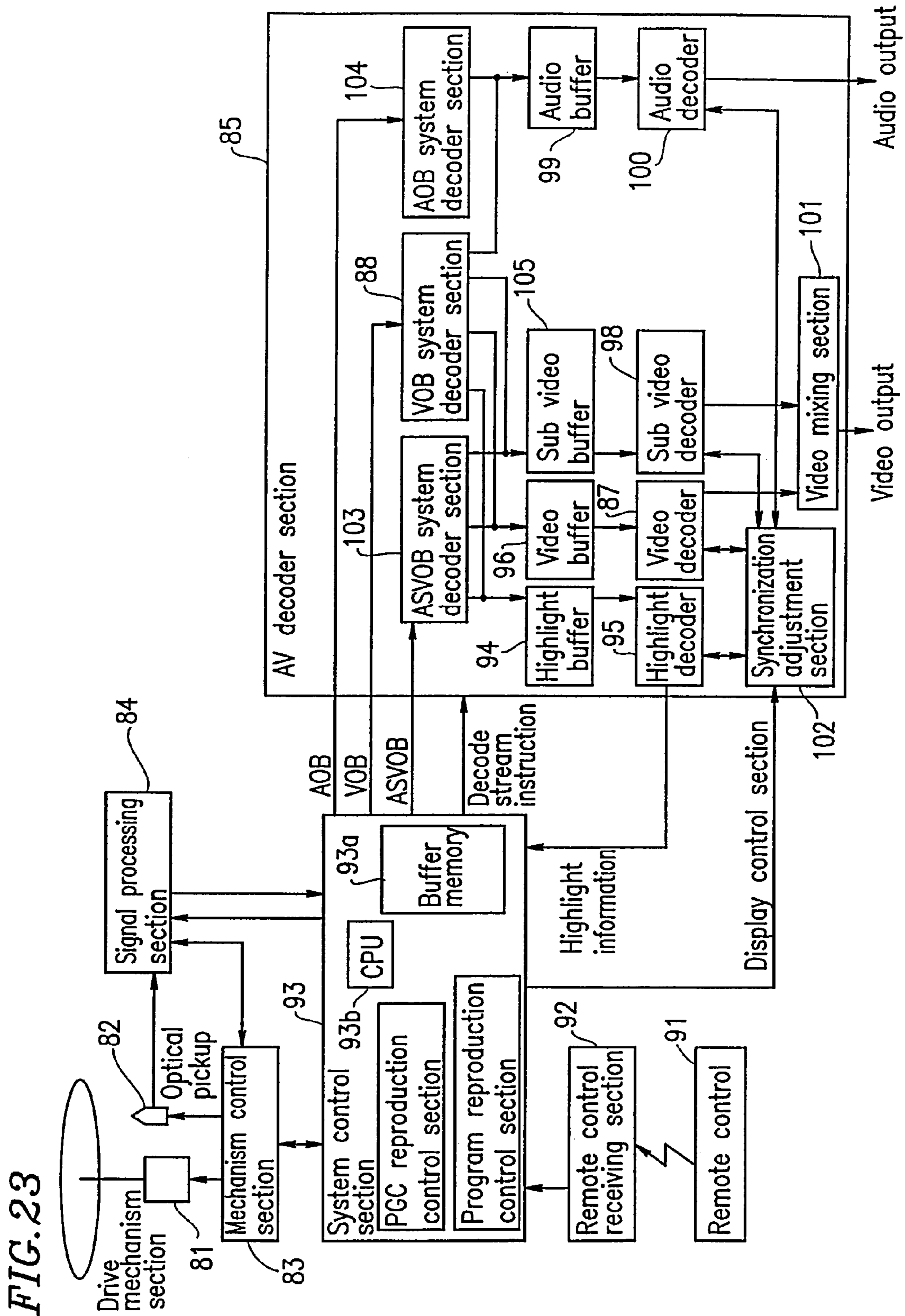

FIG. 24

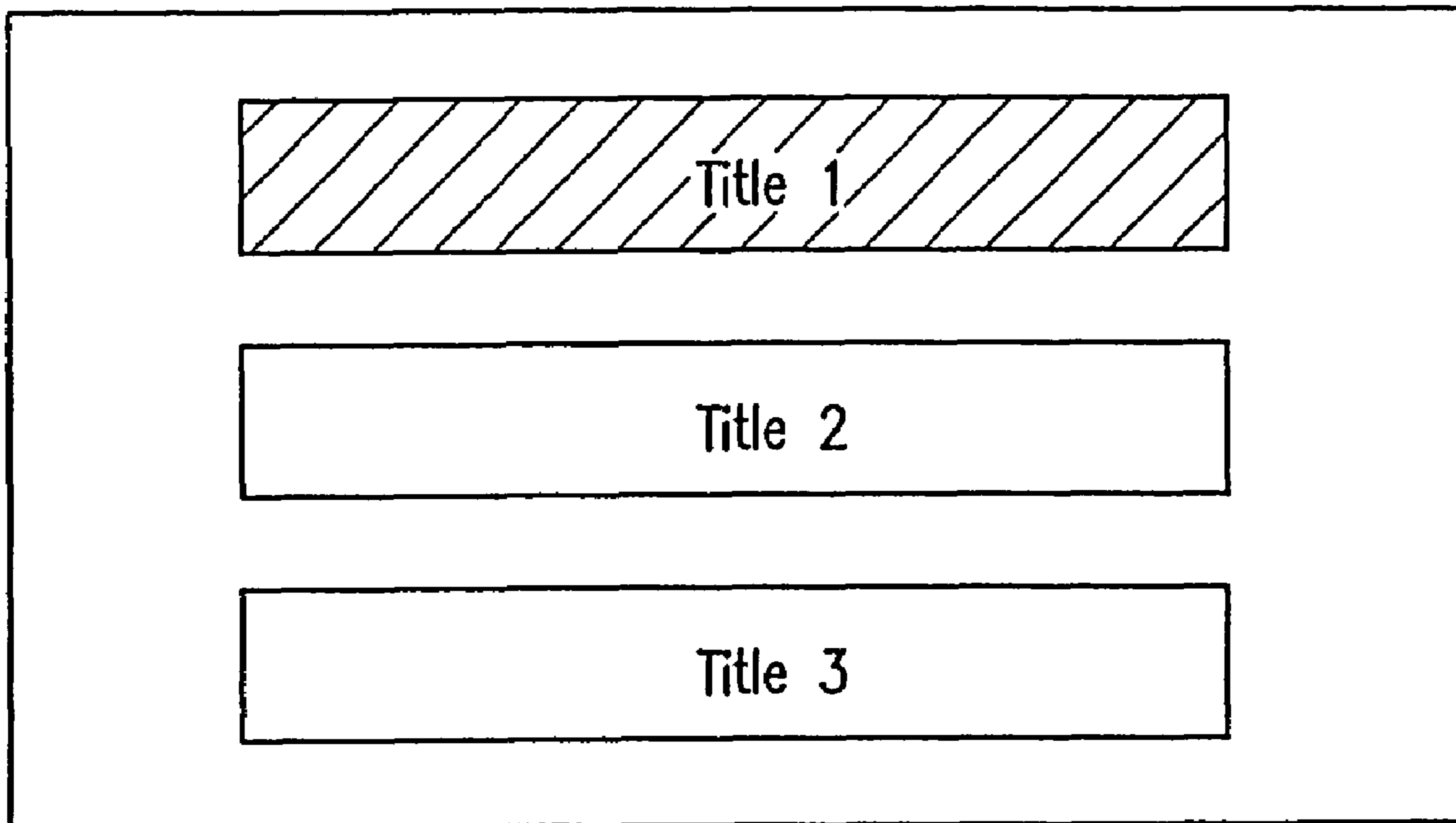

FIG. 25

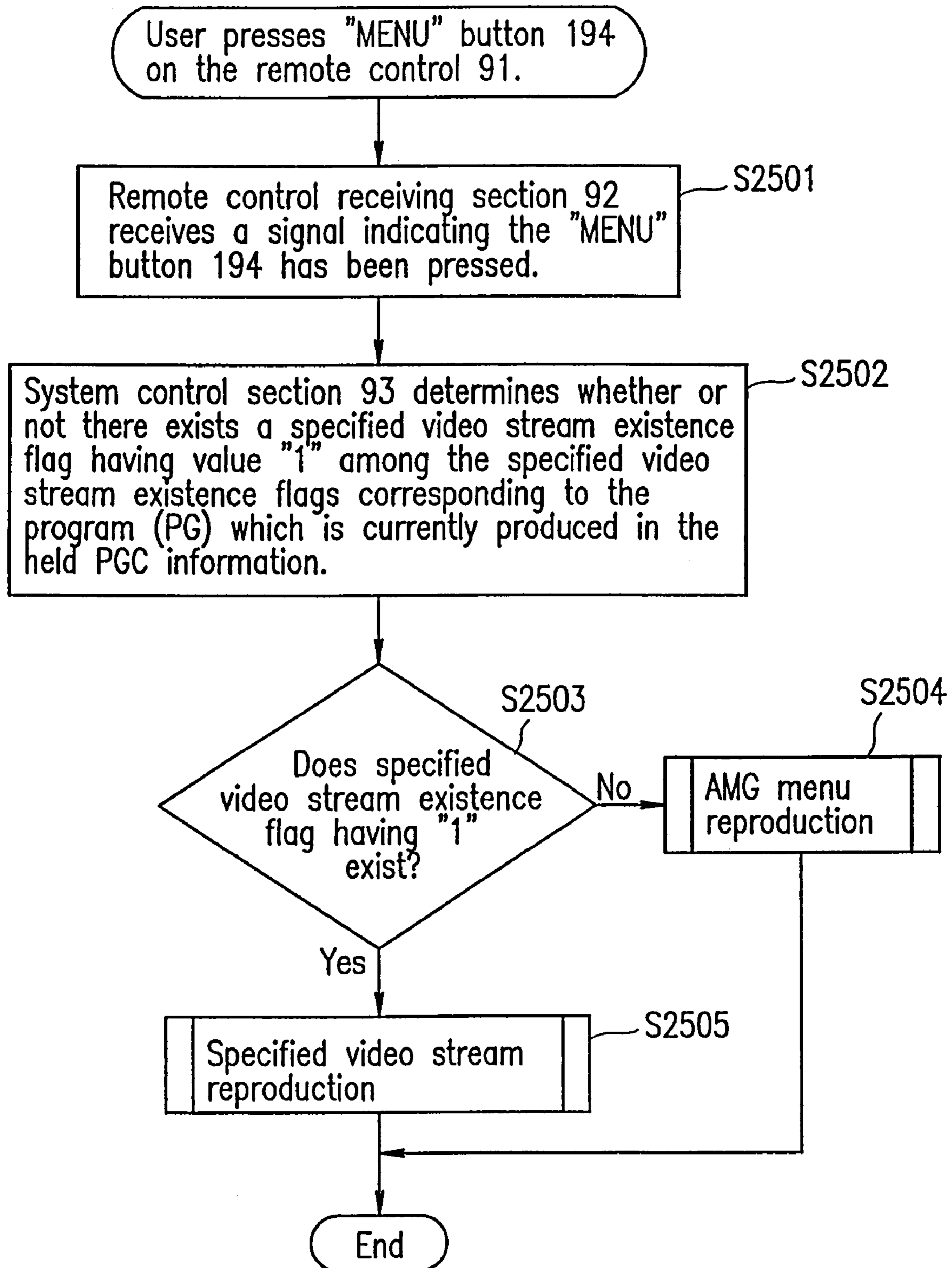

FIG. 26

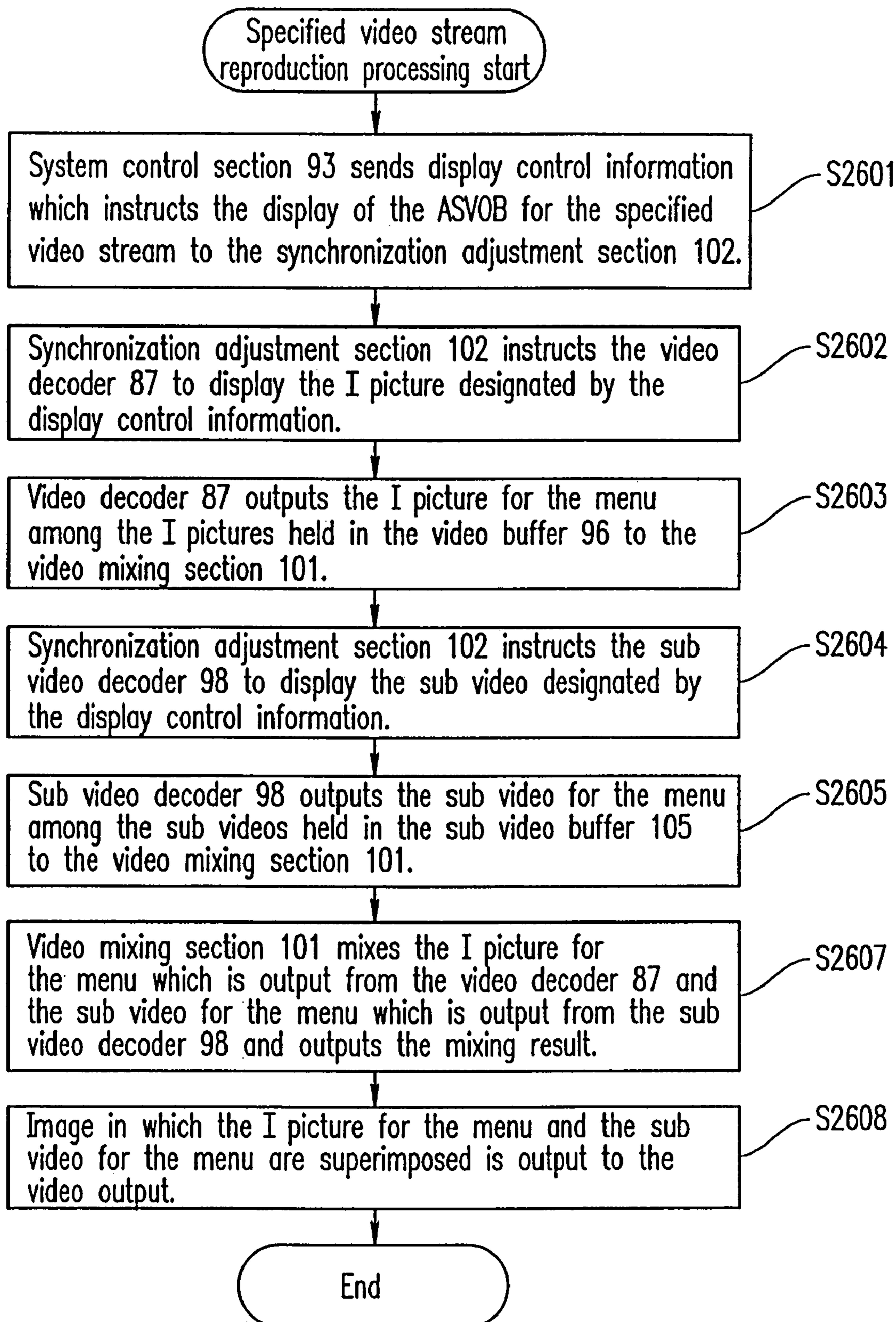
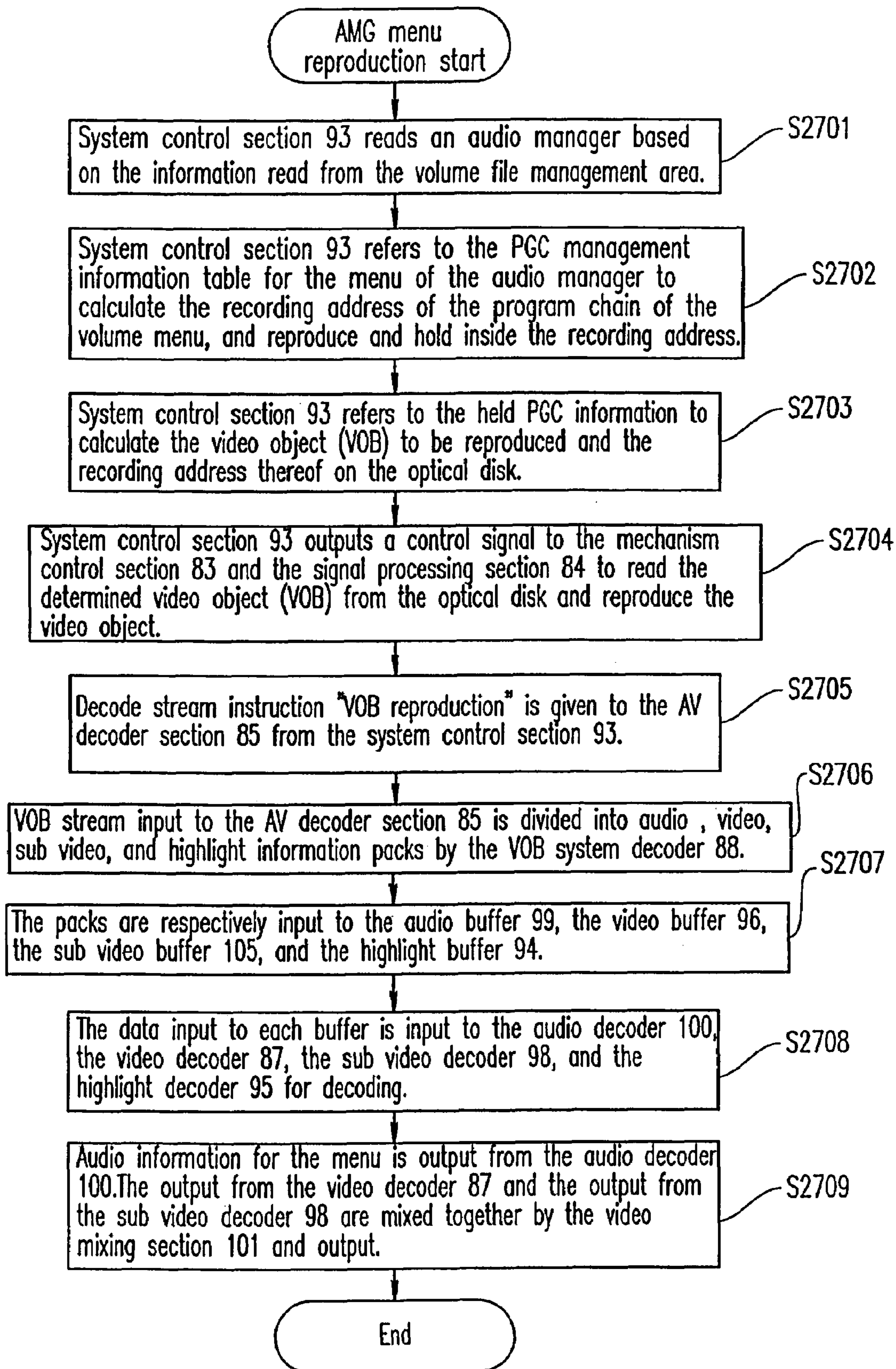

FIG. 27



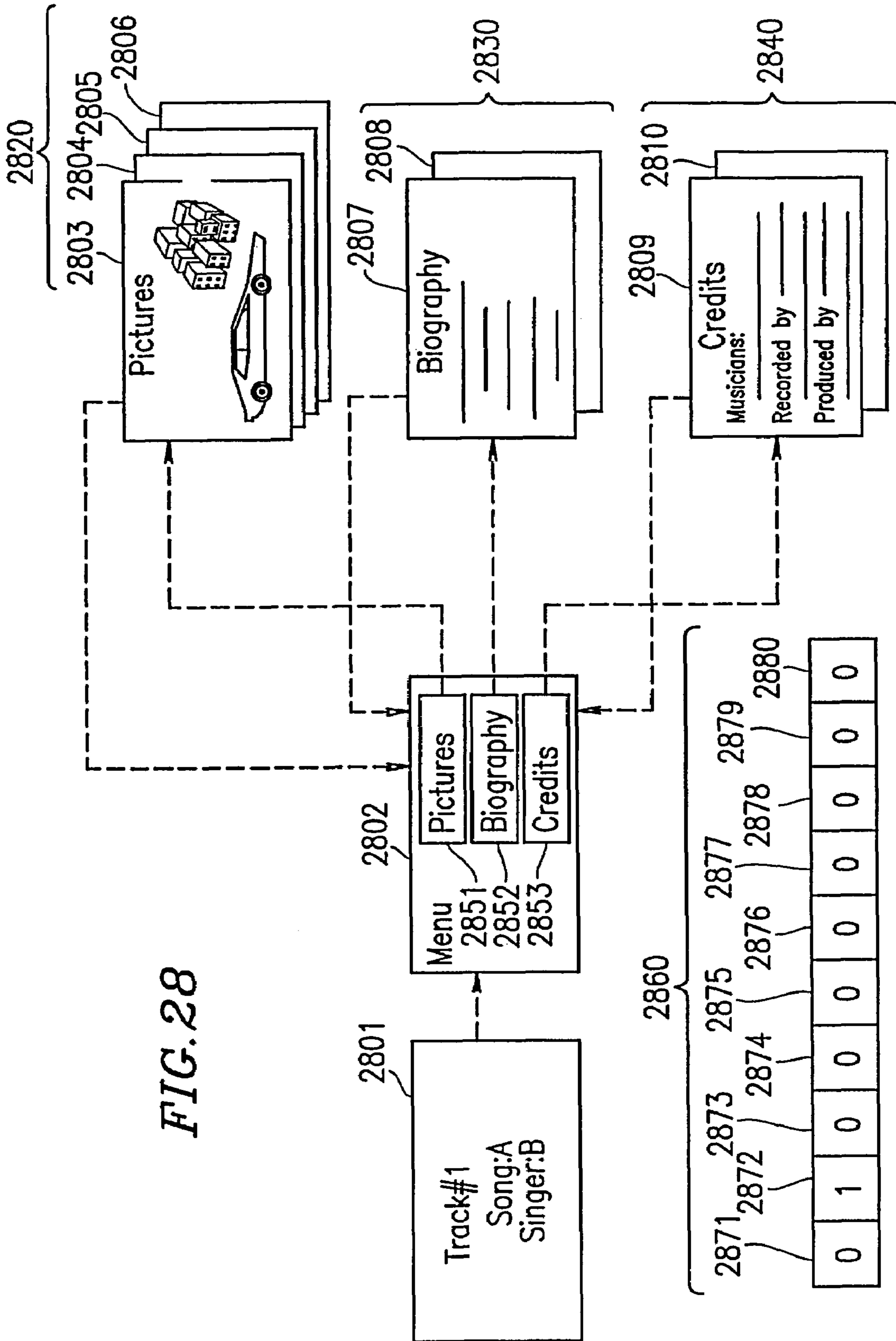

FIG. 28

**OPTICAL DISK, REPRODUCTION
APPARATUS, REPRODUCTION METHOD,
AND RECORDING MEDIUM**

This is a continuation application of application Ser. No. 11/124,539, filed May 6, 2005, which is a divisional of application Ser. No. 10/338,060, filed Jan. 7, 2003, now U.S. Pat. No. 6,907,188, which is a continuation of application Ser. No. 09/525,336, filed Mar. 10, 2000, now U.S. Pat. No. 6,574,419, the entire disclosures of which are each incorporated herein by reference.

BACKGROUND OF THE INVENTION

1. Field of the Invention:

The present invention relates to an optical disk having audio data and still picture data recorded thereon, a reproduction apparatus and a reproduction method for reproducing information recorded on the optical disk, and a recording medium having a program stored thereon for causing the reproduction apparatus to carrying out a method for reproducing information recorded on the optical disk.

2. Description of the Related Art:

One application for a DVD-Audio is a "slide show" application for reproducing a plurality of still pictures in a prescribed order synchronously with (or asynchronously with) reproduction of audio information. A typical "slide show" application is a music application for sequentially displaying still pictures related to the lyrics of a song synchronously with reproduction of the song.

In a conventional music application, a plurality of still pictures to be displayed for a specific song and the order of displaying the plurality of still pictures are predetermined.

Title producers have demanded a system in which a plurality of still picture groups are prepared for a specific song and one of the still picture groups is selectively displayed. Herein, the term "still picture group" refers to a group of a plurality of still pictures.

In order to select one of the plurality of still picture groups in accordance with an input from a user, a menu needs to be displayed. Preferably, such a menu can be retrieved at an arbitrary time by operating a button on a device such as a remote control or the like.

However, the contents of the menu are different from one song to another. Providing a menu retrieval button for each song requires many menu retrieval buttons, which makes operation by a remote control or other devices difficult.

SUMMARY OF THE INVENTION

According to an aspect of the invention, an optical disk includes an audio data storage area for storing audio data; a still picture data storage area for storing a plurality of pieces of still picture data; and a management area for storing reproduction control information for controlling reproduction of the audio data and the plurality of pieces of still picture data. The reproduction control information has flag information representing specified still picture data among the plurality of pieces of still picture data.

In one embodiment of the invention, the flag information represents that the specified still picture data is not included in the plurality of pieces of still picture data.

According to another aspect of the invention, a reproduction apparatus for reproducing information stored on the above-described optical disk is provided. The reproduction apparatus includes a reading section for reading the audio data and the plurality of pieces of still picture data from the

optical disk; and a reproduction control section for controlling reproduction of the audio data and the plurality of pieces of still picture data in accordance with the reproduction control information. The reproduction control section specifies the specified still picture data among the plurality of pieces of still picture data in accordance with the flag information.

In one embodiment of the invention, the flag information represents that the specified still picture data is not included in the plurality of pieces of still picture data.

According to still another aspect of the invention, a reproduction method for reproducing information stored on the above-described optical disk is provided. The method includes the steps of reading the audio data and the plurality of pieces of still picture data from the optical disk; and controlling reproduction of the audio data and the plurality of pieces of still picture data in accordance with the reproduction control information. The step of controlling includes the step of specifying the specified still picture data among the plurality of pieces of still picture data in accordance with the flag information.

In one embodiment of the invention, the flag information represents that the specified still picture data is not included in the plurality of pieces of still picture data.

According to still another aspect of the invention, a recording medium having recorded thereon a program for causing a reproduction apparatus to carry out a reproduction method for reproducing information stored on the above-described optical disk is provided. The reproduction method includes the steps of reading the audio data and the plurality of pieces of still picture data from the optical disk; and controlling reproduction of the audio data and the plurality of pieces of still picture data in accordance with the reproduction control information. The step of controlling includes the step of specifying the specified still picture data among the plurality of pieces of still picture data in accordance with the flag information.

In one embodiment of the invention, the flag information represents that the specified still picture data is not included in the plurality of pieces of still picture data.

Thus, the invention described herein makes possible the advantages of providing an optical disk, a reproduction apparatus, a reproduction method, and a recording medium for allowing specific still picture data (for example, a menu) which is different among a plurality of audio programs (for example, a plurality of songs) included in an audio title set to be retrieved by operating a common button.

These and other advantages of the present invention will become apparent to those skilled in the art upon reading and understanding the following detailed description with reference to the accompanying figures.

BRIEF DESCRIPTION OF THE DRAWINGS

FIG. 1A is an external view of an optical disk **100** in an example according to the present invention;

FIG. 1B is a view illustrating a cross-section of the optical disk **100**;

FIG. 1C is a view illustrating an enlarged cross-section of the optical disk **100**;

FIG. 1D is a view illustrating pits formed in the optical disk **100**;

FIG. 2A is a view illustrating a track of the optical disk **100**;

FIG. 2B is a diagram illustrating a sector structure of optical disk **100**;

3

FIG. 3 is a diagram illustrating a logical structure of the optical disk 100;

FIG. 4 is a diagram illustrating a data structure of a video title set 400;

FIG. 5 is a diagram illustrating a data structure of an audio still video set 500;

FIG. 6A is a diagram illustrating a data structure of an audio still video unit 513;

FIG. 6B is a diagram illustrating a data structure of the audio still video unit 513;

FIG. 7 is a diagram illustrating a data structure of a highlight pack 531;

FIG. 8 is a diagram illustrating a data structure of an audio still video set management information 501;

FIG. 9A is a diagram illustrating a data structure of an audio title set 900;

FIG. 9B is a diagram illustrating a data structure of the audio title set 900;

FIG. 10 is a diagram illustrating a data structure of PGC information 943;

FIG. 11A is a diagram illustrating a data structure of an audio still video display list 1071;

FIG. 11B is a diagram illustrating a data structure of the audio still video display list 1071;

FIG. 11C is a diagram illustrating a data structure of the audio still video display list 1071;

FIG. 11D is a diagram illustrating a data structure of the audio still video display list 1071;

FIG. 12 is a diagram illustrating a data structure of an audio manager 1200;

FIG. 13 is a diagram schematically illustrating the correspondence between ASVs and ATSSs stored in the optical disk 100;

FIG. 14 is a diagram schematically illustrating the correspondence among audio programs, AOBs, cells, ASVUs and ASVOBs stored in the optical disk 100;

FIG. 15 is a diagram showing exemplary contents of program information 1026 and an audio still video reproduction information search pointer 1028;

FIG. 16A is a diagram showing exemplary contents of audio still video reproduction information (ATS_ASV_PBI#1) 1029;

FIG. 16B is a diagram showing exemplary contents of audio still video reproduction information (ATS_ASV_PBI#2) 1029;

FIG. 17 is a diagram showing exemplary contents of cell reproduction information 1027;

FIG. 18 is a diagram showing exemplary contents of ATS_PG_ASV_PBI#1 through #5;

FIG. 19 is a diagram showing exemplary contents of audio still video unit general information (ASVU_GI);

FIG. 20A is a diagram schematically illustrating the correspondence between the reproduction timing of the audio program and the display timing of the still picture;

FIG. 20B is a diagram schematically illustrating the correspondence between the reproduction timing of the audio program and the display timing of the still picture;

FIG. 21 is an external view of a DVD player 1, and a TV monitor 2 and a remote control 91 which are connected to the DVD player 1;

FIG. 22 is a view illustrating an exemplary operation panel 91a of the remote control 91;

FIG. 23 is a block diagram illustrating the structure of the DVD player 1 in an example according to the present invention;

FIG. 24 is a view illustrating an exemplary video menu;

4

FIG. 25 is a flowchart illustrating an operation of a reproduction apparatus when the "menu" button 194 of the remote control 91 is pressed;

FIG. 26 is a flowchart illustrating specified video stream reproduction processing;

FIG. 27 is a flowchart illustrating AMG menu reproduction processing; and

FIG. 28 is a view illustrating an image of a title which can be created by the specified video stream reproduction processing.

DESCRIPTION OF THE EMBODIMENTS

Hereinafter, the present invention will be described by way of illustrative examples with reference to the accompanying drawings.

First, a structure of the optical disk will be described.

(1) Physical Structure of an Optical Disk

FIG. 1A is an external view of an optical disk 100 in an example according to the present invention. The optical disk 100 is, for example, a DVD which is a multi-media optical disk. FIG. 1B is a view showing a cross-section of the optical disk 100 taken long line X-X' in FIG. 1A. FIG. 1C is an enlarged view of section Y shown in FIG. 1B.

As shown in FIG. 1B, the optical disk 100 is formed by laminating a first transparent substrate 108, an information layer 109, an adhesive layer 110, a second transparent layer 111, and a printing layer 112 for printing a label, in this order.

The first transparent substrate 108 and the second transparent substrate 111 are reinforcing substrates formed of an identical material. In the example shown in FIG. 1B, the first transparent substrate 108 and the second transparent substrate 111 each have a thickness of about 0.6 mm. The first transparent substrate 108 and the second transparent substrate 111 can have a thickness in the range of about 0.5 mm to about 0.7 mm.

The adhesive layer 110 is provided between the information layer 109 and the second transparent substrate 111 in order to adhere the information layer 109 and the second transparent substrate 111.

Among the two main surfaces of the information layer 109, the main surface in contact with the first transparent substrate 108 has a reflective film (not shown) provided thereon. The reflective film is formed of a thin metal film or the like. The reflective film has concave and convex pits which are formed at a high density by a molding technology.

FIG. 1D shows a shape of the pits formed in the reflective film. In the example shown in FIG. 1D, each pit has a length of about 0.4 μm to about 2.13 μm . The optical disk 100 has one spiral track formed therein. Each pit is formed along the spiral track so that two pits adjacent in the radial direction of the optical disk 100 are about 0.74 μm apart from each other. Thus, a plurality of pits are formed in the spiral track.

When the optical disk 100 is irradiated by an optical beam 113, an optical spot 114 is formed on the information layer 109 as shown in FIG. 1C. Information stored on the optical disk 100 is detected as a change in the reflectance of a portion of the information layer 109 irradiated with the optical spot 114.

The diameter of the optical spot 114 on the optical disk 100 is about $1/1.6$ of the diameter of an optical spot on a CD (compact disk). The reason is that the numeral aperture (NA) of an objective lens for the optical disk 100 is larger than the numerical aperture NA of an objective lens for the CD, and

the wavelength λ of the optical beam for the optical disk **100** is shorter than the wavelength λ for the CD.

The optical disk **100** having such a physical structure can have about 4.7 Gbyte of information stored on one side thereof. The capacity of about 4.7 Gbytes is close to 8 times the recording capacity of the conventional CD. Such a large recording capacity of the optical disk **100** can significantly improve the quality of moving pictures, and also can significantly extend the reproduction time period of moving pictures. Whereas the reproduction time period of the conventional video CD is 74 minutes, the reproduction time period of the DVD is 2 hours or more.

The fundamental technology which realized such a large recording capacity is the reduction in the spot diameter D of the optical beam. The spot diameter D is given by the expression: spot diameter D =wavelength λ of the laser beam/numerical aperture NA of the objective lens. Accordingly, the spot diameter D can be reduced by shortening the wavelength λ of the laser beam and increasing the numerical aperture NA of the objective lens. It should be noted that when the numerical aperture NA of the objective lens is increased, frame aberration occurs due to the relative inclination (i.e., tilt) of the surface of the optical disk **100** with respect to the axis of the optical beam. For the optical disk **100**, the frame aberration is reduced by reducing the thickness of the first and/or second transparent substrates **108** and **111**. When the thickness of the first and/or second transparent substrates **108** and **111** is reduced, there can be another problem that the mechanical strength of the optical disk **100** is lowered. The strength of the optical disk **100** is reinforced by providing another substrate to the first and/or second transparent substrates **108** and **111**, thus solving the problem of the mechanical strength.

In order to read information recorded on the optical disk **100**, red semiconductor laser light having a wavelength as short as 650 nm and an objective lens having a numerical aperture (NA) as large as about 0.6 mm are used. By further using a transparent substrate as thin as about 0.6 mm as each of the first and second transparent substrates **108** and **111**, information of about 4.7 Gbytes is allowed to be recorded on one side of the optical disk **100** having a diameter of 120 mm.

FIG. 2A schematically shows a spiral track **20** is formed in the information layer **109** of the optical disk **100** from an inner portion toward an outer periphery. The spiral track **20** is divided into prescribed units referred to as sectors. In FIG. 2A, the sectors are represented by $S1, S2, \dots, S99$ and $S100$. Information recorded on the optical disk **100** is read on a sector-by-sector basis.

FIG. 2B shows an internal structure of the sector. The sector includes a sector header area **21**, a user data area **22**, and an error correction code storage area **23**.

The sector header area **21** has a sector address for identifying the sector and an error detection code for the sector address stored therein. Based on the sector address, a disk reproduction apparatus determines from which sector among the plurality of sectors information should be read.

The user data area **22** can have 2 kbytes information stored therein.

In the error correction code storage area **23**, an error correction code for the sector header area **21** and the user data area **22** included in the sector which includes the error correction code storage area **23** are stored. For reading data from the user data area **22**, the disk reproduction apparatus performs error detection using the error correction code and

performs error correction in accordance with the results of the error detection. Thus, data reading reliability is guaranteed.

(2) Logical Structure of the Optical Disk

FIG. 3 shows a logical structure of the optical disk **100**. As shown in FIG. 3, the optical disk **100** includes a lead-in area **31**, a volume area **32**, and a lead-out area **33**. These areas are located from an inner portion toward an outer periphery of the optical disk **100** in the order of the lead-in area **31**, the volume area **32**, and the lead-out area **33**. These areas can be identified by identification information included in the sector addresses of physical sectors. The physical sectors are located in an increasing order of the sector addresses thereof.

The lead-in area **31** has data for stabilizing an operation of the disk reproduction apparatus at the start of reading, and the like, stored therein.

The lead-out area **33** does not have any meaningful data stored therein. The lead-out area **33** is used for notifying the disk reproduction apparatus of the termination of reproduction.

The volume area **32** has digital data corresponding to the application stored therein. The physical sectors included in the volume area **32** are managed as logical blocks. The logical blocks are respectively supplied with and identified with logical block numbers. The first physical sector in the volume area **32** is supplied with logical block number 0, and the physical sectors following the first physical sector are supplied with sequential logical block numbers after 0.

As shown in FIG. 3, the volume area **32** includes a volume file management area **32a**, an audio zone area **32b**, and a video zone area **32c**. The volume file management area **32a** and the audio zone area **32b** are indispensable, but the video zone area **32c** is optional. In other words, the video zone area **32c** does not need to be existent.

In the volume file management area **32a**, file system management information for managing a plurality of logical blocks as a file in accordance with ISO 13346 is stored.

The file system management information is information representing the correspondence between file names of a plurality of files and addresses of a plurality of logical blocks occupied by each file. The disk reproduction apparatus realizes access to the optical disk **100** on a file-by-file basis based on the file system management information. Specifically, the disk reproduction apparatus refers to the file system management information to obtain addresses of the logical blocks corresponding to a given file name, and accesses the logical blocks based on the obtained addresses. Thus, digital data of a desired file can be read.

The audio zone area **32b** includes an audio manager (AMG: Audio Manager) **1200** and at least one audio title set (ATS: Audio Title Set) **900** stored therein. The audio zone area **32b** can have an audio still video set (ASV: Audio Still Video Set) **500**.

The audio title set **900** includes a plurality of pieces of audio data and management information for managing the reproduction order of the plurality of pieces of audio data. The audio title set **900** has a data structure for allowing audio data to be managed based on the unit referred to as an audio title. Typically, an audio title corresponds to a music album including one or more tunes.

The video zone area **32c** includes a video manager (VMG: Video Manager) **410** and at least one video title set (VTS: Video Title Set) **400** stored therein.

The video title set **400** includes a plurality of pieces of video data and management information for managing the

reproduction order of the plurality of pieces of video data. The video title set **400** has a data structure for allowing video data to be managed based on the unit referred to as a video title. Typically, a video title corresponds to a video clip album including one or more video clips.

(3) Video Zone Area **32c**

The video zone area **32c** includes the video manager **410** and at least one video title set **400**.

(3.1) Video Title Set **400**

FIG. **4** shows a data structure of the video title set **400**. The video title set **400** includes a plurality of video objects for video title set menu (VTSM_VOB: Video Object for Video Title Set Menu) **402**, a plurality of video objects for video title set title (VTSTT_VOB: Video Object for Video Title Set Title) **403**, video title set management information (VTSI) **401** for managing the information such as reproduction control information of a plurality of video objects, and video title set management information backup (VTSI_BUP) **404**.

(3.1.1) Video Object for Video Title Set Title **403**

The video object for video title set title **403** is packetized in units of 2 kbytes. The video object for video title set title **403** includes video data compressed by the MPEG1 format or the MPEG2 format. The video object for video title set title **403** can include a plurality of pieces of audio data in addition to the video data. In this case, the audio data can be encoded by the LPCM, AC3, MPEG-AUDIO or DTS format.

The video object for video title set title **403** includes a main video stream. The video object for video title set title **403** can include a plurality of sub video streams in addition to the main video stream. In this case, the sub video stream is obtained by connecting a plurality of pieces of run-length-compressed still picture data and control information into one piece of data. The sub video stream is used for displaying subtitles or for displaying a button on the video.

(3.1.2) Video Object for Video Title Set Menu **402**

The video object for video title set menu **402** will not be described since it is irrelevant to the gist of the present invention. Hereinafter, the video object for video title set title **403** and the video object for video title set menu **402** may be referred to as "VOB".

(3.1.3) Video Title Set Management Information **401**

The video title set management information **401** includes information (not shown) for managing the reproduction order of the video objects for video title set menu **402** and the video objects for video title set title **403**, and reproduction control information (not shown).

The reproduction control information includes attribute information regarding each of video, audio and sub video. The attribute information regarding video includes, for example, information representing encoding format, aspect ratio, resolution and frame rate. The attribute information regarding audio includes, for example, information representing encoding format, quantization number, quantization frequency, and number of channels. The reproduction control information can include the number of audio streams and the number of sub video streams.

The video title set management information **401** can include various information other than the above-mentioned information. Such information will not be described herein since it is irrelevant to the gist of the present invention.

(3.2) Video Manager

The video manager will not be described herein since it is irrelevant to the gist of the present invention.

The items which are not described in sections (3.1) and (3.2) are described in detail in "DVD-Specification for Read-Only Disc Part 3 Video Specifications". If necessary, refer to this document.

(4) Audio Zone Area **32b**

The audio zone area **32b** includes the audio manager **1200** and at least one audio title set **900**. The audio zone area **32b** can include the audio still video set **500**.

(4.1) Audio Still Video Set **500**

FIG. **5** shows a data structure of the audio still video set **500**. The audio still video set **500** includes audio still video set management information (ASVSI) **501**, an audio still video object set (ASVOBS) **502**, and audio still video set management information backup (ASVSI_BUP) **503**.

The audio still video object set (ASVOBS) **502** includes a plurality of audio still video units (ASVU: Audio Still Video Unit) **513**.

(4.1.1) Audio Still Video Unit **513**

FIGS. **6A** and **6B** show a data structure of one audio still video unit **513**. One audio still video unit **513** can include up to 99 audio still video objects (ASVOB: Audio Still Video Object) **521**. It should be noted that the size of one audio still video unit **513** is limited to 2 Mbytes at the maximum.

The audio still video object **521** includes a highlight back (HLI_PCK) **531** and at least one still picture pack (SPCT_PCK) **533**. The audio still video object **521** can also include at least one sub video pack (SP_PCK) **532**. The audio still video object **521** does not need to include any sub video pack **532**.

FIG. **6A** shows an exemplary data structure of the audio still video object **521** (ASVOB#1) not including any sub video pack; and FIG. **6B** shows an exemplary data structure of the audio still video object **521** (ASVOB#1) including a sub video pack **532**.

In the sub video pack **532**, up to 3 sub video streams can be described. The sub video pack **532** has a code for identifying a sub video stream similarly to the case of the DVD-Video Standard.

In the still picture pack **533**, only still picture data is recorded. Unlike the DVD-Video Standard, no moving picture is recorded in the still picture pack **533**. One audio still video object **521** can include a plurality of still picture packs **533**. In this case, the plurality of still picture packs **533** correspond to data for one still picture. Unlike the DVD-Video Standard, audio data cannot be recorded in the audio still video object **521**.

FIG. **7** shows a data structure of the highlight pack **531**.

The highlight pack **531** includes audio still video highlight information (ASV_HLI: Audio Still Video Highlight Information) **711**.

The audio still video highlight information **711** has the following information regarding the corresponding audio still video object **521** recorded therein: whether or not there is button display, display start time, display end time, button display end time, button display method, button color information, button display position information, transition information during button operation, information on execution processing while the button is pressed, and the like.

(4.1.2) Audio Still Video Set Management Information **501**

The audio still video set management information **501** includes reproduction control information and management information on the audio still video unit **513**.

FIG. 8 shows a data structure of the audio still video set management information **501**. The audio still video set management information **501** includes audio still video unit management information (ASVUI: Audio Still Video Unit Information) **811** and an audio still video address map (ASV_ADMAP: Audio Still Video Address Map) **812**.

The audio still video unit management information **811** includes the number of audio still video units **513** included in the audio still video set **500**, display attribute of still pictures and the button, button display color information, and audio still video unit general information.

The audio still video unit general information includes the number of audio still video objects **521** included in the audio still video unit **513** and the start address of the audio still video unit **513**.

The audio still video address map **812** includes address information on the audio still video objects **521** included in the audio still video unit **513**.

(4.2) Audio Title Set **900**

The audio title set **900** has one of two data structures selectively. That is, the audio title set **900** has one of two different data structures in accordance with whether the audio title set **900** includes an audio object (AOB: Audio Object) or not. Hereinafter, the audio object may be referred to as “AOB”.

FIG. 9A shows a data structure of the audio title set **900** when including audio objects.

As shown in FIG. 9A, the audio title set **900** includes a plurality of audio objects **923**, audio title set management information (ATSI) **911** for managing reproduction order information and the reproduction control information of the plurality of audio objects **923**, and audio title set management information backup (ATSI_BUP) **913**.

FIG. 9B shows a data structure of the audio title set **900** when not including any audio object.

As shown in FIG. 9B, the audio title set **900** does not include any audio object **923**. In this case, the video object for video title set title **403** is reproduced instead of the audio object **923**. Such reproduction is performed by causing the audio title set **900** to refer to the video objects for video title set title **403** included in the video title set **400**.

As shown in FIG. 9B, the audio title set **900** includes audio title set management information **911** for managing reproduction order information and reproduction control information of the plurality of video objects for video title set title **403**, and the audio title set management information backup **913**.

(4.2.1) Audio Object **923**

Each audio object **923** is packetized in units of 2 kbytes. The audio object **923** includes audio data encoded by the LPCM format, packetized PCM format (which is a loss-less compression format), AC3 format, DTS format, or the like. The audio object **923** can include real-time text data in addition to the audio data. The real-time text data is considered to be used for displaying lyrics or the like.

(4.2.2) Audio Title Set Management Information **911** (when the Audio Title Set **900** Includes an Audio Object **923**)

The audio title set management information **911** includes reproduction order management information and reproduction control information on the plurality of audio objects **923**. The reproduction order of the plurality of audio objects **923** is designated by a program chain (PGC) similarly to the case of the DVD-Video Standard.

As shown in FIG. 9A, the audio title set management information **911** includes an audio title set management table (ATSI_MAT) **921** and a PGC management information table (ATS_PGCIT) **922**.

The audio title set management table **921** is header information of the audio title set management information **911**. The audio title set management table **921** includes an audio object storage position **931**, a PGC management information table storage position **932**, audio object attribute information **933**, an audio data down mix coefficient **934** and the like.

The PGC management information table **922** includes audio title set PGC management information table information (ATS_PGCITI) **941**, and a plurality of audio title set PGC information search pointers (ATS_PGCI_SRP) **942**, and a plurality of pieces of audio title set PGC information (ATS_PGCI) **943**. Hereinafter, the audio title set PGC information **943** may be referred to as “PGC information 943”.

The audio title set PGC management information table information **941** is header information of the PGC management information table **922**. In the audio title set PGC management information table information **941**, the number of the audio title set PGC information search pointers **942** stored in the PGC management information table **922** and the like are stored.

Each audio title set PGC information search pointer **942** is index information of a plurality of program chains stored in the PGC management information table **922**. The audio title set PGC information search pointer **942** is used for designating PGC information which is first executed for each title.

In each piece of the PGC information **943**, the recording position of at least one audio object **923** on the optical disk **100** and the reproduction order thereof are described. Reproduction of identical audio objects **923** can be described in different pieces of PGC information **943**.

FIG. 10 shows a data structure of one piece of PGC information **943**. The PGC information **943** includes audio title set PGC general information (ATS_PGC_GI) **1011**, an audio title set program information table (ATS_PG_IT) **1012**, an audio title set cell reproduction information table (ATS_C_PBIT) **1013**, and an audio title set audio still video reproduction information table (ATS_ASV_PBIT) **1014**.

The audio title set PGC general information **1011** includes an audio title set program number **1031** (which shows the number of programs included in one audio title), an audio title set cell number **1032** (which shows the number of cells included in one audio title), PGC reproduction time period **1022**, address information **1023** on the audio title set program information table **1012**, address information **1024** on the audio title set cell reproduction information table **1013**, and address information **1025** on the audio title set audio still video reproduction information table **1014**.

Hereinafter, the “program” refers to an audio program included in an audio title. For example, when the audio title corresponds to a music album, a “program” corresponds to a tune included in the music album.

In the audio title set program information table **1012**, a plurality of pieces of audio title set program information (ATS_PGI) **1026** are described. The audio title set program information (ATS_PGI) **1026** represents information on programs included in one audio title.

In each of the plurality of pieces of audio title set program information **1026**, the following information is described: audio program physical allocation information **1041** (which shows whether or not an AOB corresponding to the present audio program and an AOB corresponding to the immedi-

ately previous audio program are recorded at physically continuous positions on the optical disk **100**), audio program time attribute information **1042** (which shows whether or not the time information on the AOB corresponding to the present audio program and the time information on the AOB corresponding to the immediately previous audio program are continuous to each other), an audio program start cell number **1043** (which shows the first cell number included in the audio program), reproduction start audio cell time **1044** (which shows reproduction start time of the first audio cell included in the audio program), audio program total reproduction time period **1045** (which shows the total reproduction time period of the audio program), audio pause time period **1046** (which shows the silent time period before the reproduction of the first audio cell included in the audio program is started), and the like.

In the audio title set cell reproduction information table **1013**, a plurality of pieces of audio title set cell reproduction information (ATS_C_PGI) **1027** are described. Each piece of audio title set cell reproduction information **1027** represents information on the cell corresponding to the AOB to be reproduced.

In each piece of the plurality of pieces of audio title set cell reproduction information **1027**, the following information is described: a cell index number **1051** showing the order of the cells included in the audio program, a cell type **1052** showing the type of the cell, a cell start address **1053** showing the start address of the cell, a cell end address **1054** showing the end address of the cell, and the like.

The cell type **1052** shows, for example, whether the cell is a silent cell or an audio cell. The cell start address **1053** and the cell end address **1054** are described with, for example, the relative address with respect to the first pack of the first AOB included in the audio title set **900**.

The audio title set audio still video reproduction information table **1014** includes a plurality of audio title set audio still video reproduction information search pointers (ATS_PG_ASV_PBI_SRP) **1028** and a plurality of pieces of audio title set audio still video reproduction information (ATS_ASV_PBI) **1029**.

Each audio title set audio still video reproduction information search pointer **1028** corresponds to each program included in one audio title set. Accordingly, the number of the audio title set audio still video reproduction information search pointers **1028** is equal to the number of pieces of the audio title set program information **1026**.

In each audio title set audio still video reproduction information search pointer **1028**, the following information is described: an audio still video unit number (ASVUN) **1061** (which shows the audio still video unit **513** used for program reproduction), an audio still video reproduction mode (ASV_DMOD) **1062**, and a start address **1063** and an end address **1064** of the audio still video reproduction information (ATS_ASV_PBI) **1029** used for program reproduction.

As the audio still video unit number **1061**, the number in conformity to the recording order of the audio still video units **513** stored in the audio still video set **500** is described. By this number, the audio still video unit **513** used for program (PG) reproduction is specified.

The audio still video reproduction mode **1062** includes a display timing mode and a display order mode. As the display timing mode, "slide show mode" or "browsable mode" can be designated; and as the display order mode, "sequential mode", "random mode" or "shuffle mode" can be designated.

Each piece of audio title set audio still video reproduction information **1029** includes a plurality of audio still video display lists (ASV_DLIST) **1071**. As the data structure of the audio still video display list **1071**, four different data structures usable in accordance with the audio still video reproduction mode **1062** are defined. Two data structures are defined for the display timing mode, one for the "slide show mode" and one of the "browsable mode". Two data structures are defined for the display order mode, one for the "sequential mode" and one for "random mode" or "shuffle mode". Thus, four (2×2) data structures are defined. Hereinafter, the four data structures will be described one by one.

FIG. **11A** shows a data structure of the audio still video display list **1071** when the display timing mode is the "slide show mode" and the display order mode is the "sequential mode".

In the audio still video display list **1071**, the following information is described: an ASV number (ASV Number) **1101**, a specified video stream existence flag (Entry DLIST Flag) **1102**, a forcedly selected button number (FOSL_BTNN: Forcedly Selected Button Number) **1103**, a program number (Program Number) **1104**, display timing information (Display Timing) **1105**, a start effect mode (Start effect mode) **1106**, an end effect mode (End effect mode) **1107**, a start effect period (Start effect period) **1108**, and an end effect period (End effect period) **1109**.

The ASV number **1101** is information for designating the audio still video object **521** to be displayed among at least one audio still video object **521** included in the audio still video unit **513**.

The specified video stream existence flag **1102** has value "1" or "0". The value "1" of the specified video stream existence flag **1102** indicates that the audio still video reproduced in accordance with the audio still video reproduction information **1029** including the specified video stream existence flag **1102** is the specified video stream to be used for the menu. The value "0" of the specified video stream existence flag **1102** indicates that the audio still video reproduced in accordance with the audio still video reproduction information **1029** including the specified video stream existence flag **1102** is a video stream other than the specified video stream to be used for the menu.

Within one program (PG), only two states are permitted: in one state, one of a plurality of specified video stream existence flags **1102** has the value "1" and the other flags have the value "0"; in the other state, all the plurality of specified video stream existence flags **1102** have the value "0". Existence of a specified video stream existence flag **1102** having the value "1" in the program (PG) indicates that a specified video stream to be used for the menu exists in the program. Non-existence of a specified video stream existence flag **1102** having the value "1" in the program (PG) (i.e., all the specified video stream existence flags **1102** in the program (PG) have the value "0") indicates that there is no specified video stream to be used for the menu in the program.

The forcedly selective button number **1103** indicates the button number selected as default when the still picture designated by the ASV number **1101** is displayed.

The program number **1104** and the display timing information **1105** are information for designating the timing to start the display of the still picture designated by the ASV number **1101**. In other words, when the reproduction of the program designated by the program number **1104** reaches a display time designated by the display timing information **1105**, the display of the still picture and the button is started in accordance with the display list **1071**.

The start effect mode **1106** and the end effect mode **1107** are information for designating display effects provided when a still picture is switched to another still picture. For example, display effects such as “fade”, “cut”, “dissolve” and “wipe” can be designated by the start effect mode **1106** and the end effect mode **1107**.

The start effect period **1108** and the end effect period **1109** are information indicating the time period in which the display effect designated by the start effect mode **1106** and the end effect mode **1107** is maintained.

FIG. **11B** shows a data structure of the audio still video display list **1071** when the display timing mode is the “slide show mode” and the display order mode is the “random mode” or the “shuffle mode”.

The data structure shown in FIG. **11B** is identical with the data structure shown in FIG. **11A** except that the ASV number **1101** in FIG. **11A** is replaced with a reserved (Reserved) area in FIG. **11B**.

In the display list **1071** in FIG. **11B**, the ASV number **1101** does not need to be designated. The reason is that although the timing to switch one still picture to another is designated by the program number **1104** and the display timing information **1105**, the next still picture to be displayed is determined randomly.

In the “random mode”, the audio still video object to be displayed next is determined completely randomly among the audio still video unit. In the “shuffle mode”, the audio still video object is determined randomly, but the audio still video object once selected is not selected again until all the other audio still video objects have been selected.

The contents in the reserved area is not specified. The reserved area is, for example, blank.

FIG. **11C** shows a data structure of the audio still video display list **1071** when the display timing mode is “browsable mode” and the display order mode is “sequential mode”.

The data structure shown in FIG. **11C** is identical with the data structure shown in FIG. **11A** except that the program number **1104** in FIG. **11A** is replaced with a reserved (Reserved) area in FIG. **11C** and that the display timing information **1105** in FIG. **11A** is replaced with a maximum display duration time period (Max duration time) **1111** and a minimum display duration time period (Min duration time) **1112** in FIG. **11C**.

In the display list **1071** in FIG. **11C**, neither the program number **1104** nor the display timing information **1105** need to be designated. The reason is that in the “browsable mode”, one still picture is switched to another still picture in response to the input from the user at arbitrary timing. Thus, the viewer is allowed to change pages freely.

The maximum display duration time period **1111** is used for automatically executing page forwarding even when there is no input from the user. When there is no input from the user even after the time period designated by the maximum display duration time period **1111** passes, the still picture is automatically switched to the next still picture.

The minimum display duration time **1112** is used for displaying the still picture designated by the ASV number **1101** for at least a minimum duration. Until the time period designated by the minimum display duration time **1112** passes, the still picture is not switched to the next still picture even if there is an input from the user.

FIG. **11D** shows a data structure of the audio still video display list **1071** when the display timing mode is the “browsable mode” and the display order mode is the “random mode” or the “shuffle mode”.

(4.2.3) Audio Title Set Management Information **911** (when the Audio Title Set **900** does not Include an Audio Object **923**)

Referring again to FIG. **9B**, the audio title set **900** refers to the video objects for video title set title included in another video title set. As a result, a video object for video title set title is reproduced instead of the audio object. In this case, the basic structure that the audio title set management information **911** includes the audio title set management table **921** and the PGC management information table **922** is maintained.

The audio title set management table **921** and the PGC management information table **922** are different in this case from the case where the audio title set **900** includes the audio object **923** in the following points.

In the audio title set management table **921**, address information on the video title set including the video object referred to and the storage position of the video object in the video title set are described instead of the audio object storage position **931**.

The PGC management information table **922** does not include the audio title set audio still video reproduction information table. The reason is that it is not necessary to refer to the audio still video since the video object already includes video information.

(4.3) Audio Manager **1200**

FIG. **12** shows a data structure of the audio manager **1200**. The audio manager **1200** is information for reproduction control which the disk reproduction apparatus first refers to for reproducing the optical disk **100** with priority being put on audio information.

The audio manager **1200** includes audio manager information (AMGI) **1211**, an audio manager menu VOB (AMGM_VOBS) **1212**, and audio manager information backup (AMGI_BUP) **1213**.

The audio manager information **1211** includes an audio manager information management table (AMGI_MAT) **1221** including attribute information and pointer information, audio title management information **1222** including the number of audio titles and the like, a plurality of audio title search pointers (ATT_SRP) **1223** each including audio title search information, and an audio manager menu PGC management information table (AMGM_PGCI_UT) **1224** including PGC information for an audio manager menu.

The audio manager information management table **1221** includes an AMG identifier (AMG_ID) for identifying the audio manager **1200**, an AMG end address (AMG_EA) which is an end address for table management, an AMGI end address (AMGI_EA), a version number (VERN), a volume set identifier (VLMS_ID), a title set number (TS_Ns) showing the number of title sets included in the volume, a provider identifier (PVR_ID) for identifying the provider which created the disk, an AMGI_MAT end address (AMGI_MAT_EA), an automatic execution flag (Auto_Play_Flag) for defining the operation of the reproduction apparatus when the disk is inserted, and ASVS start address (ASVS_SA) for recording the position of the audio still picture set, address information on tables for AMG and AMGI, and AMGM_VOBS attribute information including VOB attribute information included in the audio manager.

Although not shown in FIG. **12**, each audio title search pointer table (ATT_SRP) **1223** includes “audio title type” indicating the type of each title, “in-title program number” indicating the number of programs included in the title, “title reproduction time period” indicating the reproduction time period of the title, “audio title set number” indicating the

audio title set number to which each title belongs, "ATS title number" indicating the title number of each title in the audio title set, and "ATS address" indicating the address of the audio title set to which each title belongs.

FIG. 13 schematically shows the correspondence between the ASV and ATS stored in the optical disk 100.

The ATS can include a plurality of pieces of PGC information (ATS_PGCI). However, in the example shown in FIG. 13, the ATS includes one piece of PGC information (ATS_PGCI).

In the PGC information, the reproduction order of audio programs in an audio program group (Program #1, Program #2, . . . Program #L) is described. Each audio program is an access unit of audio data. Each audio program includes a plurality of pieces of audio cell reproduction information (ATS_C_PBI). The audio cell reproduction information is a minimum management unit. The audio cell reproduction information points to an AOB including actual audio data. Thus, the audio data to be reproduced corresponding to the audio program is determined.

In the PGC information, audio still video reproduction information (ATS_ASV_PBI) indicating how the still picture should be reproduced is described on a program-by-program basis. A plurality of audio programs can share the same audio still video reproduction information. In the example shown in FIG. 13, Program #1 and Program #2 share ATS_ASV_PBI#1. The reason for this is that the audio still video reproduction information table (ATS_ASV_PBIT) is structured so that ATS_PG_ASV_PBI_SRP corresponding to the audio program can point to one of the plurality of pieces of ATS_ASV_PBI.

The PGC information designates an ASVU included in the ASV in order to display a plurality of still pictures in relation to the reproduction of the audio program.

The ASVU is also a unit used by the reproduction apparatus for buffering still picture data. More specifically, before reproducing one audio program, the reproduction apparatus reads a still picture data group in the designated ASVU from the optical disk 100. Accordingly, the reproduction apparatus does not need to read the still picture data group from the optical disk 100 during the reproduction of the audio program (for example, music program).

Before reproducing the next audio program, the reproduction apparatus determines whether or not the still picture data group in the ASVU required for the next audio program exists in a main memory of the reproduction apparatus. When the still picture data group in the ASVU required for the next audio program exists in the main memory of the reproduction apparatus, the reproduction apparatus does not need to newly read the still picture data group from the optical disk 100.

When the audio title producer desires to quickly switch one audio program to the next audio program, the PGC information can be structured so that an audio program and the next audio program share one ASVU. By structuring the PGC information in this manner, the reproduction apparatus does not need to buffer the still picture data group in the ASVU required for the next audio program. As a result, the reproduction apparatus can quickly switch two audio programs reproduced continuously.

The ATS_ASV_PBI manages the order of still pictures to be displayed in the form of a display list (ASV_DLIST). In the display list (ASV_DLIST), the still picture in the ASVU to be displayed is designated by the ASV number.

As described above, the PGC information allows different still pictures to be displayed for different audio programs. The PGC information also allows the same still picture to be

displayed for a plurality of audio programs. When one audio program is switched to another audio program, the still pictures to be displayed can be switched with no need for muting.

FIG. 14 schematically shows the correspondence among the audio programs, AOBs, cells, ASVUs and ASVOBs stored on the optical disk 100. Such a correspondence is defined by the PGC information (ATS_PGCI). In FIG. 14, arrow t represents the time axis.

In the example shown in FIG. 14, one audio title includes four audio programs. Audio program #1 corresponds to AOB#1, audio program #2 corresponds to AOB#2, and audio programs #3 and #4 correspond to AOB#3. Herein, the AOBs are recorded on the optical disk 100 in the order of AOB#1, AOB#2 and then AOB#3.

Audio program #1 includes cells #1 and #2; audio program #2 includes cells #3, #4 and #5; audio program #3 includes cells #6 and #7; and audio program #4 includes cell #8. Cells #1, #3 and #6 are silent cells, and cells #2, #4, #5, #7 and #8 are audio cells.

Audio programs #1 and #2 correspond to ASVU #1, and audio programs #3 and #4 correspond to ASVU #2. The display of ASVOB#1 is started in synchronization with the reproduction start of cell #2; the display of ASVOB#2 is started in synchronization with the reproduction start of cell #4; the display of ASVOB#3 is started in synchronization with the reproduction start of cell #5; and the display of ASVOB#4 is started in synchronization with the reproduction start of cell #7; and display of ASVOB#5 is started in synchronization with the reproduction start of cell #8.

FIG. 15 shows exemplary contents of the program information 1026 and contents of the audio still video reproduction information search pointer 1028 regarding each of audio programs #1 through #4. In the example shown in FIG. 15, it is assumed that the reproduction time period of each and every audio cell is 60 seconds (5,400,000 in PTS (Presentation Time Stamp)) and that the reproduction time period of each and every silent cell is 1 second (90,000 in PTS).

FIG. 16A shows exemplary contents of the audio still video reproduction information 1029 (ATS_ASV_PBI#1) corresponding to audio programs #1 and #2 shown in FIG. 14.

FIG. 16B shows exemplary contents of the audio still video reproduction information 1029 (ATS_ASV_PBI#2) corresponding to audio programs #3 and #4 shown in FIG. 14.

FIG. 17 shows exemplary contents of the cell reproduction information 1027 regarding each of cells #1 through #8 shown in FIG. 14. In the example shown in FIG. 17, it is assumed that the audio data is encoded at a sampling rate of 48 kHz and 16 bits, and 2 ch. In this case, the number of packs of the silent cells is 96 and the number of packs of the audio cells is 5760.

FIG. 18 shows exemplary contents of ATS_PG_ASV_PBI#1 through #5. In the example shown in FIG. 18, it is assumed that the number of still picture packs is 50.

FIG. 19 shows exemplary contents of audio still video unit general information (ASVU_GI).

The addresses 1063 and 1064 (FIG. 15) of the audio still video reproduction information included in the audio still video reproduction information search pointer 1028 can be represented by, for example, a relative address using the position at which the first ASVOB is recorded as a reference address. However, so long as the position of the ASVOB on the optical disk 100 can be specified, addresses 1063 and 1064 can be each represented by an arbitrary address. For example, when the audio still video unit general information

(ASVU_GI) includes address information usable as the reference address, the addresses **1063** and **1064** can be represented by relative addresses with respect to that reference address.

In the example shown in FIG. **15**, the ASV reproduction mode **1062** of audio programs **#1** and **#2** is "slide show". In this case, the still picture is reproduced in synchronization with audio information. Since the ASVU number **1061** of audio programs **#1** and **#2** is "1", ASVU#1 is read to the buffer of the reproduction apparatus before the reproduction of audio programs **#1** and **#2**. Next, ATS_ASV_PBI#1 is referred to based on the addresses **1063** and **1064** of ATS_ASV_PBI. As a result, the display of still pictures corresponding to display lists **#1**, **#2** and **#3** of the ATS_ASV_PBI#1 shown in FIG. **16A** is started at the display timing designated by the program number **1103** and the display timing information **1105**. The display timing is in synchronization with the reproduction time of audio information to be reproduced together with the still pictures.

In other words, the display of the still picture designated by display list **#1** of ATS_ASV_PBI#1 is started when PTS becomes 90,000 during the reproduction of AOB#1. The display of the still picture designated by display list **#2** of ATS_ASV_PBI#1 is started when PTS becomes 90,000 during the reproduction of AOB#2. The display of the still picture designated by display list **#3** of ATS_ASV_PBI#1 is started when PTS becomes 5,580,000 during the reproduction of AOB#2.

When the ASV reproduction mode **1062** is "slide show", the display of the still picture is displayed at the timing predetermined in synchronization with the audio reproduction time as described above. The still picture cannot be updated by the user's instruction.

FIG. **20A** schematically shows the relationship between the reproduction timing of the audio program and the display timing of the still picture when the ASV reproduction mode **1062** is "slide show".

In the example shown in FIG. **15**, the ASV reproduction mode **1062** of audio programs **#3** and **#4** is "browsable". In this case, the still picture is reproduced asynchronously with the audio information. The display of the still pictures corresponding to the display lists **#1** and **#2** of ATS_ASV_PBI#2 shown in FIG. **16B** is updated in response to the user's operation or command. When no user's operation is performed within the display duration time period designated by the maximum display time period information **1111**, the still picture is automatically switched to the next still picture.

For reproducing audio program **#3**, ASVU#2 is selected based on the ASVU number **1061** corresponding to audio program **#3**. Before the reproduction of the audio program **#3**, ASVU#2 is read into the buffer of the reproduction apparatus. Next, the ATS_ASV_PBI#2 is referred to based on the addresses **1063** and **1064** of ATS_ASV_PBI. Since the audio program number **1104** of display list **#1** of ATS_ASV_PBI#2 is "3", ASVOB#4 is displayed based on the ASV number **1101** of display list **#1**.

When a button of a remote control or the like corresponding to Next_DLIST is pressed, which instructs the reproduction of the next display list, ASVOB#5 is displayed based on the ASV number **1101** of display list **#2** of ATS_ASV_PBI#2. When the display is switched from ASVOB#4 to ASVOB#5, the display effects in accordance with start effect mode **1106**, the end effect mode **1107**, the start effect period **1108**, and the end effect period **1109** are provided.

When there is no user's operation during the display duration time period of 5,490,000 (i.e., about 1 minute) designated by the maximum display time period information **1111** of display list **#1**, ASVOB#5 is displayed based on the ASV number **1101** of the next display list **#2**. The display duration time period 5,490,000 matches the reproduction time period of audio program **#3**.

After the reproduction of audio program **#3** is completed, audio program **#4** is reproduced. When there is a user's operation during the reproduction of audio program **#3**, the display of ASVOB#4 is switched to the display of ASVOB#5 during the reproduction of audio program **#3**. When there is no user's operation during the reproduction of audio program **#3**, the display of ASVOB#5 is started simultaneously with the start of the reproduction of audio program **#4**.

When the reproduction is started from audio program **#4**, ASVU#2 is selected based on the ASVU number **1061** corresponding to audio program **#4**, and ASVU#2 is read into the buffer of the reproduction apparatus before the audio program **#4** is reproduced. Then, ATS_ASV_PBI#2 is referred to based on the addresses **1063** and **1064** of ATS_ASV_PBI. Since the first display list, among the display lists included in ATS_ASV_PBI#2, which has audio program number **1104** of "4" is display list **#2**, ASVOB#5 is displayed based on the ASV number **1101** of display list **#2**.

After ASVOB#5 is displayed, the display of ASVOB#5 is changed in response to the user's operation or command. The audio program number of the display list is only effective when the ASVU is changed. In this case, the audio program number of the display list is referred to in order to determine the first ASVOB to be reproduced.

FIG. **20B** schematically shows the relationship between the reproduction timing of the audio program and the display timing of the still picture when the ASV reproduction mode **1062** is "browsable".

When the value of the maximum display time period information **1111** is a value representing "infiniteness", the corresponding ASVOB is continuously displayed until the user's operation is performed or a command is executed. As the value representing infiniteness, the maximum value (i.e., binary value in which all digits are "1") is usable, but other values are also usable. In the case of the "browsable mode", a value representing "infiniteness" can always be set in the maximum display time period information **1111**.

As described above, AOB and ASVOB are reproduced simultaneously by a decoder, unlike the reproduction of VOB.

The reproduction method of VOB and the reproduction method of AOB and ASVOB are identical with each other in that video information is output together with the audio information. However, in the case of ASVOB, the video information is still picture information including only I picture.

The reproduction method of VOB and the reproduction method of AOB and ASVOB are different from each other in the following points.

A first difference is in the storage position of the data. In the case of VOB, the audio information and the video information are multiplexed together and recorded on the optical disk as one system stream. In the case of AOB and ASVOB, the audio information and the video information are recorded in different areas of the optical disk as different system streams.

A second difference is in the synchronization method of the audio information and the still picture information. VOBs are processed for reproduction by a decoder one by

one. An STC, which is a reference clock, is reset by an SCR (System Clock Reference) in the “pack header” in the first pack of the system stream. The decoder refers to the STC to output the audio information and the still picture information at the output timing represented by the PTS in the “packet header” in each pack.

AOBs and ASVOBs are processed for reproduction simultaneously by a decoder. A plurality of ASVOBs to be reproduced in synchronization with an AOB are read from the optical disk and input to the decoder before the AOB. The ASVOBs input to the decoder are not displayed immediately, unlike the VOB. The ASVOBs are decoded in accordance with the MPEG decode model. More specifically, the STC, which is the reference clock, is reset by the SCR in the first pack of each ASVOB. The ASVOB is decoded in accordance with the PTS in the packet. It can be considered that the post-decoding data of the plurality of ASVOBs to be reproduced in synchronization with the AOB is accumulated in the decoder, but actually, pre-decoding ASVOB data is accumulated in an appropriate buffer in the decoder.

When the ASVOB is completely input to the decoder, the AOB is read from the optical disk and input to the decoder. When the AOB is input to the decoder, the STC as the reference clock is reset by the SCR in the first pack of the AOB in a similar manner to the case of the VOB. The decoder refers to the STC to output the AOB at the output timing represented by the PTS in each pack header.

The information indicating the output timing of the ASVOB is stored in the display list, which is included in the PGC information. The area of the optical disk storing the information indicating the output timing of the ASVOB is different from the area of the optical disk storing the ASVOB. The information indicating the output timing of the ASVOB is supplied to the decoder separately from the ASVOB. Each ASVOB in the decoder is not output in synchronization with the STC, but is output in accordance with the information indicating the output timing of the ASVOB stored in the display list.

Thus, the output timing of the AOB is determined by the PTS accompanying the AOB itself, whereas the output timing of the ASVOB is determined by the information in the display list which is stored in a different area from the area storing the ASVOB.

Hereinafter, a reproduction apparatus for reproducing the information stored on the optical disk **100** will be described.

FIG. **21** shows an external view of a DVD player **1** as an exemplary reproduction apparatus for reproducing information stored in the optical disk (DVD) **100**, and a large-screen household TV monitor **2** and a remote control **91** which are connected to the DVD player **1**.

The DVD player **1** has an opening on a front surface of a chassis thereof. A driving mechanism (not shown) for loading the DVD **100** is provided in the DVD player **1** along a depth direction of the opening.

On the front surface of the DVD player **1**, a remote control receiving section **92** having a light receiving element for receiving infrared rays from the remote control **91** is provided. When the user operates a button of the remote control **91**, the infrared rays in accordance with the input from the user are emitted from the remote control **91**. In response to the infrared rays received, the remote control receiving section **92** generates an interrupt signal which indicates that a signal is received from the remote control **91**.

On a rear surface of the DVD player **1**, a video output terminal and an audio output terminal (neither is shown) are provided. By connecting AV cords to the output terminals, a

video signal reproduced from the DVD **100** can be output to the TV monitor **2**. Thus, the user can enjoy the video reproduced from the DVD **100** through the large-screen household TV monitor **2** having a size of 33 inches or 35 inches.

As can be appreciated from the above, the DVD player **1** is not connected to a computer such as a personal computer for use but is connected to a household TV monitor such as the TV monitor **2** for use as a household electric appliance.

On the surface of the remote control **91**, a plurality of buttons loaded by springs are provided. The remote control **91** outputs a code corresponding to the pressed button in the form of infrared rays.

FIG. **22** shows an exemplary operational panel **91a** of the remote control **91**. Various buttons are provided on the operational panel **91a**.

A “power” button **192** is used for turning on or off the DVD player **1**.

A “menu” button **194** is used for retrieving a title menu in the DVD **100** while video information or audio information in the DVD **100** is reproduced in accordance with the program chain. The “menu” button **194** is also used for retrieving a specified video stream (for example, branching menu) while a specified audio program included in the selected title is reproduced.

Numerical buttons (ten keys) **197** are used for instructing the DVD player **1** to perform chapter jump in the case of a movie, selection of a tune in the case of music, or the like.

Cursor buttons **198** are used for moving the cursor upward, downward, rightward and leftward to select an item.

An “enter” button **196** is used for finalizing the item selected by the cursor. When the cursor is positioned on the item, the item is displayed with a selection color defined by item color information in a management information pack. When the selection of the item is finalized by pressing the “enter” button **196**, the item is displayed with a finalization color defined by item color information in the management information pack.

Buttons **199** are used for instructing the DVD player **1** to perform operations such as “reproduction”, “stop”, “pause”, “fast forward”, “rewinding” and the like. The buttons **199** are common with other AV apparatuses.

FIG. **23** shows a structure of a DVD player **1** in an example according to the present invention. As shown in FIG. **23**, the DVD player **1** includes a drive mechanism section **81**, an optical pickup **82**, a mechanism control section **83**, a signal processing section **84**, an AV decoder section **85**, the remote control receiving section **92**, and a system control section **93**.

The drive mechanism section **81** includes a table (not shown) on which the DVD **100** is set, and a motor (not shown) for clamping and rotating the DVD **100** set on the table. The motor is, for example, a spindle motor. The table on which the DVD **100** is to be set moves inward and outward the chassis by an eject mechanism section (not shown). The user sets the DVD **100** on the table where the table is outside the chassis. Then, the table having the DVD **100** thereon is moved inside the chassis. Thus, the DVD **100** is loaded on the DVD player **1**.

The mechanism control section **83** controls a mechanism system including the drive mechanism section **81** for driving the DVD **100** and the optical pickup **82** for reading a signal stored on the DVD **100**. Specifically, the mechanism control section **83** adjusts the speed of the motor in accordance with the position of the track indicated by the system control section **93**. The mechanism control section **83** also controls

the movement of the optical pickup **82** by controlling an actuator (not shown) of the optical pickup **82**. When the accurate position of the track is detected by servo control, the mechanism control section **83** waits for a desired physical sector and then continuously reads signals from the desired physical sector.

The signal processing section **84** processes the signal read by the optical pickup **82** with amplification, waveform rectification, binarization, demodulation, error detection, and other processing. The signal read by the optical pickup **82** is converted into digital data and stored in a buffer memory **93a** of the system control section **93** on a logical block-by-logical block unit.

The system control section **93** includes a CPU **93b**. Reproduction processing performed by the reproduction apparatus (for example, PGC reproduction control processing, program reproduction control processing, and the like) can be stored on a recording medium in the form of a program. Such a recording medium can be a floppy disk or a CD-ROM. The program stored on the recording medium is installed in the system control section **93** via, for example, a floppy disk drive (not shown). The CPU **93b** executes the program installed in the system control section **93** from the recording medium. Thus, the system control section **93** can execute reproduction processing corresponding to the installed program.

The AV decoder section **85** includes an ASVOB system decoder section **103**, an AOB system decoder section **104**, and a VOB system decoder section **88**. The AV decoder section **85** is structured so as to operate these three system decoders **103**, **104** and **88** to operate synchronously or asynchronously with one another. To the ASVOB system decoder section **103**, an ASVOB including still picture data is input. To the AOB system decoder section **104**, an AOB including audio data is input. To the VOB system decoder section **88**, a VOB for video title set menu including audio data and video data in a multiplexed state and the like are input.

The ASVOB system decoder section **103** receives an ASVOB stream and distinguishes a stream ID and a sub stream ID in the header of each packet included in the ASVOB stream from each other to divide the ASVOB stream into a video packet, a PCI (highlight) packet, and a sub video packet.

The AOB system decoder section **104** receives an AOB stream and divides the data based on the packet header included in the AOB stream.

The VOB system decoder section **88** receives a VOB stream and distinguishes a stream ID and a sub stream ID in the header of each packet included in the VOB stream from each other to divide the VOB stream into an audio packet, a video packet, a PCI (highlight) packet, and a sub video packet.

The AV decoder section **85** includes a highlight buffer **94**, a video buffer **96**, a sub video buffer **105**, an audio buffer **99**, a highlight decoder **95**, a video decoder **87**, a sub video decoder **98**, an audio decoder **100**, a synchronization adjustment section **102**, and a video mixing section **101**.

The highlight information output from the PCI (highlight) packets of the ASVOB system decoder section **103** and the VOB system decoder section **88** is temporarily stored in the highlight buffer **94**.

The video packets output from the ASVOB system decoder section **103** and the VOB system decoder section **88** are temporarily stored in the video buffer **96**.

The sub video packets output from the ASVOB system decoder section **103** and the VOB system decoder section **88** are temporarily stored in the sub video buffer **105**.

The audio packets output from the AOB system decoder section **104** and the VOB system decoder section **88** are temporarily stored in the audio buffer **99**.

The highlight decoder **95** decodes the highlight information from the PCI (highlight) packets which is stored in the highlight buffer **94**. The decoded highlight information is output to the system control section **93**.

The video decoder **87** decodes the video data stored in the video buffer **96**.

The sub video decoder **98** decodes the sub video data stored in the sub video buffer **105**.

The audio decoder **100** decodes the audio data stored in the audio buffer **99**. The output from the audio decoder **100** (decoding result) is output as an audio output.

The video mixing section **101** mixes the output from the video decoder **87** (decoding result) and the output from the sub video decoder **98** (decoding result) to generate one piece of video data. The output from the video mixing section **101** is output as a video output.

The synchronization adjustment section **102** manages the synchronization of operations of the highlight decoder **95**, the video decoder **87**, the sub video decoder **98** and the audio decoder **100**.

Before starting the reproduction, the system control section **93** determines whether the reproduction mode is video-oriented or not. When the reproduction mode is determined to be video-oriented, the video manager is read based on the information read from the volume file management area.

The system control section **93** refers to the PGC management information table for the menu of the video manager to calculate a recording address of the program chain for the volume menu. The system control section **93** reproduces and holds inside the recording address. When the recording address of the program chain for the volume menu is held inside, the system control section **93** refers to the held PGC information to calculate the video object (VOB) to be reproduced and the recording address thereof on the optical disk **100**. When the video object to be reproduced is determined, the system control section **93** outputs a control signal to the mechanism control section **83** and the signal processing section **84** to retrieve the determined video object from the optical disk **100** and reproduces the video object in the following manner.

The VOB is input to the AV decoder section **85**. A decode stream instruction "VOB reproduction" is given to the AV decoder section **85** from the system control section **93**.

The VOB stream input to the AV decoder section **85** is divided into various packs included in the VOB stream by the VOB system decoder section **88**. Audio, video, sub video, and highlight information packs are respectively input to the audio buffer **99**, the video buffer **96**, the sub video buffer **105**, and the highlight buffer **94**. The highlight buffer **94** buffers only the highlight information in the PCI (highlight) packet in the highlight information pack.

The data input to each buffer is input to the audio decoder **100**, the video decoder **87**, the sub video decoder **98**, and the highlight decoder **95** for decoding.

The audio information for the menu is output from the audio decoder **100**. The output from the video decoder **87** and the output from the sub video decoder **98** are mixed together by the video mixing section **101**. The mixing result is output as a video output. The output from the highlight decoder **95** is read into the system control section **93**. As a

result, the button information or the like of each menu is stored in the memory in the system control section 93.

In this manner, a video menu for allowing the user to select one of a plurality of titles is displayed.

FIG. 24 shows an exemplary menu.

The user views the video menu shown in FIG. 24, and selects and finalizes one of a plurality of items in the video menu. For example, the user selects and finalizes the item in which he/she is interested.

It is assumed that the user designates a menu item number corresponding to either one of "title 1", "title 2" or "title 3" shown in FIG. 24 using the remote control 91. The system control section 93 receiving the designation of the menu item number from the remote control 91 refers to the button information of the highlight information in the PCI (highlight) pack included in the VOB of the video menu which is being reproduced to execute the control command corresponding to the designated number. The button information is pre-stored in the memory. The control command is, for example, "PlayTitle #n", wherein, "n" represents the title number to be reproduced.

For executing the command "PlayTitle #n", the system control section 93 refers to a title search pointer table, which is a part of the audio manager, to determine the audio title set (ATS) and the title number in the ATS.

When the audio title set is selected, the system control section 93 outputs a control signal to the mechanism control section 83 and the signal processing section 84 to reproduce the audio title set management information of the selected audio title set, sequentially reads the audio title set PGC information search pointers, which are a part of the audio title set management information, and determines the PGC information of the program chain for starting the reproduction of the title to be reproduced.

When the PGC information is determined, the system control section 93 outputs a control signal to the mechanism control section 83 and the signal processing section 84 to reproduce the determined PGC information and hold the PGC information in the inside buffer for PGC information.

When the PGC information for starting the reproduction of the title is held, the system control section 93 refers to the held PGC information to obtain the ASVU number of the first audio program information. The system control section 93 refers to the audio still video unit general information (ASVU_GI) corresponding to the ASVU number to read the ASVOB corresponding to the first audio program of the PGC information from the optical disk and input the audio still video unit general information to the AV decoder section 85. A decode stream instruction "ASVOB reproduction" is given to the AV decoder section 85 from the system control section 93. The AV decoder section 85 divides the ASVOB into packs and packets by the ASVOB system decoder section 103 and stores the packs and packets in the corresponding buffers.

The size of the video buffer 96 needs to be equal to or greater than the maximum value of the sum of the sizes of the ASVOBs in the ASVU. In order to guarantee that the optical disk 100 is reproducible by any player, all the reproduction apparatuses are required to include a video buffer 96 of a certain capacity or greater. The certain capacity is the maximum value of the total data amount of the ASVOBs included in the ASVU. In this example, the maximum value is 2 Mbytes. One I picture is 100 kbytes to 200 kbytes, and thus the 10 to 20 I pictures can be reproduced together with the audio information.

When all the ASVOBs included in the ASVU are completely input to the ASVOB system decoder section 103,

neither the highlight decoder 95, nor the video decoder 87, nor the sub video decoder 98 performs decoding. When all the ASVOBs are stored in the corresponding buffers, the audio object to be reproduced and the recording address thereof are determined by the audio title set program information table and audio title set cell reproduction information table. The AOB determined in this manner is reproduced by a control signal output to the mechanism control section 83 and the signal processing section 84.

The AOB read from the optical disk 100 is input to the AV decoder section 85. A decode stream instruction "AOB reproduction" is given to the AV decoding section 85 from the system control section 93. The AOB is made into an audio stream by the AOB system decoder section 104. The audio stream is input to the audio decoder 100 through the audio buffer 99. Thus, the audio data is prepared to be output. When the audio data is prepared to be output, the STC (reference clock) in the synchronization adjustment section 102 is reset by the SCR in the first pack of the AOB. The audio data of the AOB is output at the timing of the PTS stored in the packet header. When the output of the AOB is started, the first I picture of the ASVOB, and the highlight information and the sub picture information for the menu item which is to be displayed in an overlapping state with the I picture are decoded and output at the instruction of the synchronization adjustment section 102. It is not guaranteed that the PTS is described in all the packets of the AOB, but the audio decoder 100 outputs the audio data while supplementing the PTS.

The system control section 93 hold the still picture reproduction information of the PGC information. The still picture reproduction information includes the display timing of the still picture. The system control section 93 outputs the display control information of the still picture information to the synchronization adjustment section 102 of the AV decoder section 85 in accordance with the display timing of the still picture reproduction information. The display control information includes a wait period until the I picture of the ASVOB to be updated is designated and the update thereof is displayed. The synchronization adjustment section 102 instructs the video decoder 87 to output the designated I picture at the designated timing in accordance with the input display control information.

In other words, the ASVOB is output in accordance with the display timing information stored in an area which is different from the area storing the ASVOB, unlike the case of the AOB or VOB.

In this manner, before the audio data is reproduced, the ASVU data corresponding to the audio data is all stored in the corresponding buffers. Therefore, the highlight buffer 94, the video buffer 96, and the sub video buffer 105 need to have a capacity larger than that of the buffer defined in the MPEG2 or DVD-Video Standard.

FIG. 25 is a flowchart of an exemplary operation of the DVD player 1 when the "menu" button 194 of the remote control 91 is pressed.

When the user presses the "menu" button 194 of the remote control 91, the remote receiving section 92 receives a signal indicating that the "menu" button 194 has been pressed (step S2501).

The system control section 93 determines whether or not there exists a specified video stream existence flag having value "1" among the specified video stream existence flags corresponding to the program (PG) which is currently reproduced in the held PGC information (i.e., whether the specified video stream exists or not) (step S2502).

When it is determined that all the specified video stream existence flags are "0" in step S2503, the AMG menu reproduction processing (FIG. 27) is retrieved (step S2504).

When it is determined that there exists a specified video stream existence flag having value "1" among the specified video stream existence flags in step S2503, the specified video stream reproduction processing (FIG. 26) is retrieved (step S2505).

FIG. 26 is a flowchart of specified video stream reproduction processing. The specified video stream reproduction processing indicates reproduction of a specified still picture among a plurality of still pictures corresponding to the audio program. The specified still picture is, for example, used as a menu for allowing the user to select one of the plurality of still picture groups.

The system control section 93 sends display control information which instructs the display of the ASVOB for the specified video stream from the held PGC information to the synchronization adjustment section 102 (step S2601). The ASVOB for the specified video stream is, for example, the final ASVOB in the ASVU.

The synchronization adjustment section 102 instructs the video decoder 87 to display the I picture designated by the display control information (step S2602).

The video decoder 87 outputs the I picture used for the menu among the I pictures held in the video buffer 96 to the video mixing section 101 (step S2603).

The synchronization adjustment section 102 instructs the sub video decoder 98 to display the sub video designated by the display control information (step S2604).

The sub video decoder 98 outputs the sub video used for the menu among the sub videos held in the sub video buffer 105 to the video mixing section 101 (step S2605).

The video mixing section 101 mixes the I picture used for the menu which is output from the video decoder 87 and the sub video used for the menu which is output from the sub video decoder 98 and outputs the mixing result (step S2607).

An image in which the I picture for the menu and the sub video for the menu are superimposed is output to the video output (step S2608). The image is displayed on, for example, the TV monitor 2 connected to the DVD player 1. The user can watch the image displayed on the TV monitor 2.

FIG. 27 is a flowchart of AMG menu reproduction processing. The AMG menu reproduction processing indicates reproduction of the AMG menu, which is a video menu for allowing the user to select the title to be reproduced among a plurality of titles shown in FIG. 24.

The system control section 93 reads an audio manager based on the information read from the volume file management area (step S2701).

The system control section 93 refers to the PGC management information table for the menu of the audio manager to calculate the recording address of the program chain of the volume menu, and reproduce and hold inside the recording address (step S2702).

When the recording address of the program chain of the volume menu is held inside, the system control section 93 refers to the held PGC information to calculate the video object (VOB) to be reproduced and the recording address thereof on the optical disk 100 (step S2703).

When the video object to be reproduced is determined, the system control section 93 outputs a control signal to the mechanism control section 83 and the signal processing section 84 to read the determined video object (VOB) from the optical disk 100 and reproduce the video object (step S2704).

The VOB system stream is input to the AV decoder section 85. Simultaneously, a decode stream instruction "VOB reproduction" is given to the AV decoder section 85 from the system control section 93 (step S2705).

The VOB stream input to the AV decoder section 85 is divided into various packs (i.e., audio, video, sub video, and highlight information packs) included in the VOB stream by the VOB system decoder section 88 (step S2706).

The packs are respectively input to the audio buffer 99, the video buffer 96, the sub video buffer 105, and the highlight buffer 94 (step S2707). The highlight buffer 94 buffers only the highlight information in the PCI (highlight) packet in the highlight information pack.

The data input to each buffer is input to the audio decoder 100, the video decoder 87, the sub video decoder 98, and the highlight decoder 95 for decoding (step S2708).

The audio information for the menu is output from the audio decoder 100. The output from the video decoder 87 and the output from the sub video decoder 98 are mixed together by the video mixing section 101 and output (step S2709).

The output from the highlight decoder 95 is read into the system control section 93. As a result, the button information or the like of each menu is stored in the memory in the system control section 93. In this manner, the AMG menu shown in FIG. 24 is displayed.

FIG. 28 shows an image of a title which can be created by the specified video stream reproduction processing described with reference to FIG. 26.

In FIG. 28, reference numerals 2801 through 2810 represent still pictures reproduced with high quality audio information. The dotted arrows represent the order of display of the still pictures.

FIG. 28 shows a still picture group 2820 labeled "Pictures", a still picture group 2830 labeled "Biography", and a still picture group 2840 labeled "Credits". Herein, the term "still picture group" refers to a plurality of one or more still pictures which are grouped together.

The still picture group 2820 includes still pictures 2803 through 2806 which are photos of players of tunes and pictures related to the tune. The still picture group 2830 includes still pictures 2807 and 2808 representing summary of the career and list of works of the players of the tunes as texts and photos. The still picture group 2840 includes still pictures 2809 and 2810 representing the players, recording engineers, producers and the like of the tunes mainly as texts.

The still picture 2802 labeled "Menu" is used for selecting one of the plurality of still picture groups. On the still picture 2802, a "Pictures" button 2851 and a "Biography" button 2852, and a "Credits" button 2853 are displayed.

The still pictures 2801 through 2810 shown in FIG. 28 are reproduced in the order described in the reproduction control information which is stored on the optical disk 100. However, the still picture 2802 is structured so as to be displayed after switching from another arbitrary still picture in response to the input from the user. For example, when the user presses the "Menu" button 194 on the remote control 91 while the still picture group 2820 labeled "Pictures" are reproduced, the still picture which is being reproduced is switched to the still picture 2802 without any interruption in sound reproduced. As a result, the any one of the still picture groups 2820, 2830 and 2840 can be selected.

When the "Pictures" button 2851 is selected while the still picture 2802 is displayed, the still picture 2802 is switched to a still picture in the still picture group 2820 (for example, the still picture 2803) without any interruption in sound

reproduced. When the “Biography” button **2852** or the “Credits” button **2853** is selected while the still picture **2802** is displayed, the still picture **2802** is switched to another still picture in a similar manner.

For displaying the still picture **2802**, the above-mentioned ASVOB for the specified video stream is used.

In FIG. **28**, reference numeral **2860** represents flag information indicating the specified still picture acting as a menu among the plurality of still pictures **2801** through **2810**. The flag information **2860** includes a plurality of specified video stream existence flags **2871** through **2880** respectively corresponding to the plurality of still pictures **2801** through **2810**. Each of the plurality of specified video stream existence flags **2871** through **2880** can be included in, for example, the display list **1071** as the specified video stream existence flag **1102** shown in FIGS. **11A** through **11D**.

In the example shown in FIG. **28**, the still picture **2802** is the specified still picture acting as the menu. Accordingly, the value of the specified video stream existence flag **2872** corresponding to the still picture **2802** is set to “1”. The value of the specified video stream existence flags **2871** and **2873** through **2880** corresponding to all the other still pictures **2801** and **2803** through **2810** is set to “0”. When the “Menu” button **194** on the remote control **91** is pressed, the still picture **2802** corresponding to the specified video stream existence flag **2872** having the value “1” is displayed regardless of which other still picture is being reproduced.

The value of “0” of all the specified video stream existence flags **2871** through **2880** included in the flag information **2860** indicates that the plurality of still pictures **2801** through **2810** do not include any specified still picture acting as the menu.

The flag information **2860** can be defined for each of a plurality of audio programs (for examples, a plurality of tunes) included in the audio title set.

By using the flag information **2860** defined for each of the plurality of audio programs (for examples, a plurality of tunes) included in the audio title set, different specified still pictures (for example, menus) for different audio programs (for examples, different tunes) can be retrieved by a common button (for example, the “menu” button **194** of the remote control **91**).

The present invention is not limited to the above-described example.

In the above example, the specified video stream existence flag **1102** is stored in the audio still video reproduction information (ATS_ASV_PBI) **1029** as shown in FIGS. **11A** through **11D**. However, the storage position of the specified video stream existence flag **1102** is not limited to this. The specified video stream existence flag **1102** can be stored in other positions on the optical disk **100**. Alternatively, additional information can be added to the specified video stream existence flag **1102** and stored. In this manner, high speed reproduction is realized.

For example, the area in each of FIGS. **11A** and **11B** (“slide show mode”) which stores the program number **1104** is replaced with a reserved area in each of FIG. **11C** and **11D** (“browsable mode”). In the case where the existence of the specified video stream existence flag **1102** is permitted only in the “browsable mode”, the number of the audio still video display list (ASV_DLIST) **1071** referring to the specified video stream for the menu can be recorded in the reserved area. Specifically, when the number is “0”, it is understood that there is no specified video stream for the menu; and when the number is not “0”, it is understood that the number is the number of the ASV_DLIST, which is to be referred to.

Referring to FIG. **10**, bit 7 of the audio still video reproduction mode (ASV_DMOD) **1062** in the audio still video reproduction information search pointer (ATS_PG_ASV_PBI_SRP) **1028** in the audio title set audio still video reproduction information table (ATS_ASV_PBIT) **1014** may be a reserved area. In such a case, a flag indicating whether or not the specified video stream for the menu exists in this program (PG) can be recorded in bit 7 of the ASV reproduction mode **1062**. In this case, it is easier to confirm that there is no specified video stream for the menu in the program (PG) than in the case of recording the specified video stream existence flag **1102** in the audio still video display list (ASV_DLIST) **1071** shown in FIGS. **11A** through **11D**. The reason is that when the flag is recorded in bit 7 of the ASV reproduction mode **1062**, it is possible to confirm that there is no specified video stream for the menu in the program (PG) merely by checking bit 7 of the ASV reproduction mode **1062** instead of checking all the specified video stream existence flags **1102** in the display list **1071**.

Referring to FIG. **10**, bit 7 and bit 6 of the audio still video reproduction mode (ASV_DMOD) **1062** in the audio still video reproduction information search pointer (ATS_PG_ASV_PBI_SRP) **1028** in the audio title set audio still video reproduction information table (ATS_ASV_PBIT) **1014** may be reserved areas. In such case, a specified video stream existence flag can be recorded in each of bit 7 and bit 6. When bit 7 of the ASV reproduction mode **1062** is 1, it is understood that the ASVOB reproduced in the first audio still video display list (ASV_DLIST) **1071** in the audio still video reproduction information (ATS_ASV_PBI) **1029** designated by the audio still video reproduction information search pointer **1028** is the specified video stream used as the menu. When bit 6 of the ASV reproduction mode **1062** is 1, it is understood that the ASVOB reproduced in the final audio still video display list (ASV_DLIST) **1071** in the audio still video reproduction information (ATS_ASV_PBI) **1029** designated by the audio still video reproduction information search pointer **1028** is the specified video stream used as the menu. By this method, the reproduction apparatus can always determine whether or not there is a specified video stream used as the menu, by referring to the specified position.

Referring to FIG. **10**, bits 7 through 4 of the audio still video reproduction mode (ASV_DMOD) **1062** in the audio still video reproduction information search pointer (ATS_PG_ASV_PBI_SRP) **1028** in the audio title set audio still video reproduction information table (ATS_ASV_PBIT) **1014** may be reserved areas. In such a case, the number of the audio still video display list (ASV_DLIST) **1071** referring the specified video stream can be recorded in bits 7 through 4 of the ASV reproduction mode. Specifically, when the number is “0”, it is understood that there is no specified video stream for the menu; and when the number is a value other than “0” (1 through 15), it is understood that the number is the number of the ASV_DLIST to be referred to. By this method, the reproduction apparatus can determine whether or not there is a specified video stream and specify the position of the specified video stream, by referring to the audio still video reproduction information search pointer **1028**. As a result, the search performed by the reproduction apparatus becomes easier.

Referring to FIG. **10**, the 5th byte of audio title set program information (ATS_PG) **1026** in the audio title set program information table (ATS_PG_IT) **1012** may be a reserved area. In such a case, the number of the audio still video display list (ASV_DLIST) **1071** referring the specified video stream can be recorded in the 5th byte of the audio title

set program information (ATS_PG) 1026. Specifically, when the number is "0", it is understood that there is no specified video stream for the menu; and when the number is a value other than "0" (1 through 255), it is understood that the number is the number of the ASV_DLIST to be referred to. 5 By this method, the reproduction apparatus can determine whether or not there is a specified video stream and specify the position of the specified video stream, by referring to the audio title set program information 1026. As a result, the search performed by the reproduction apparatus becomes 10 easier.

Referring to FIG. 8, bits 55 through 50 of the audio still video unit general information (ASVU_GI) in the audio still video unit management information (ASVUI) 811 may be a reserved area. In such a case, the number of the audio still 15 video display list (ASV_DLIST) 1071 referring the specified video stream can be recorded in bits 55 through 50 of the audio still video unit general information. Specifically, when the number is "0", it is understood that there is no specified video stream for the menu; and when the number is a value 20 other than "0" (1 through 63), it is understood that the number is the number of the ASV_DLIST to be referred to.

In the above-described example, when the "menu" button 194 of the remote control 91 is pressed, the AMG menu is displayed where the specified video stream flag is 0, and the 25 ASVOB for the specified video stream for the menu where the specified video stream flag is 1. Alternatively, the display of the AMG menu and the ASVOB for the specified video stream for the menu can be assigned to different buttons. For example, it can be structured so that when the "Title" button 30 of the remote control 91 is pressed, the AMG menu is reproduced; and when the "menu" button is pressed, the ASVOB for the specified video stream for the menu is reproduced.

As described above, according to the optical disk, reproduction apparatus and reproduction method of the present invention, different specified still pictures (for examples, 35 menus) can be retrieved for different audio programs (for example, different tunes) included in one audio title, by operating a common button.

The specified still picture can be displayed with no interruption in the sound.

Since different specified still pictures (for examples, menus) can be displayed for different audio programs (for example, different tunes), an optimum menu can be displayed 45 for each of the plurality of audio programs.

Various other modifications will be apparent to and can be readily made by those skilled in the art without departing from the scope and spirit of this invention. Accordingly, it is not intended that the scope of the claims appended hereto be 50 limited to the description as set forth herein, but rather that the claims be broadly construed.

The invention claimed is:

1. An information recording medium for storing control information that when processed by a processor in a reproduction apparatus controls the reproduction apparatus to reproduce information stored on the information recording 55 medium, the information recording medium comprising:

- an audio data storage area for storing a plurality of pieces of audio data for at least one audio program; 60
- a still picture data storage area for storing a plurality of pieces of still picture data; and
- a management area for storing reproduction control information which defines a reproduction order of the plurality of pieces of audio data and a display order of the 65 plurality of pieces of still picture data to be displayed simultaneously with the reproduction of the plurality of

pieces of audio data, the reproduction order of the plurality of pieces of audio data and the display order of the plurality of pieces of still picture data being defined separately by the reproduction control information,

wherein the reproduction control information has specified still picture information indicating specified still picture data to be independently displayed by a specified operation regardless of the display order of the plurality of pieces of still picture data, the reproduction apparatus using the control information to reproduce the audio data and the still picture data from the information recording medium.

2. An information recording medium according to claim 1, wherein the specified still picture information represents that specified still picture data is not included in the plurality of pieces of still picture data.

3. A reproduction apparatus for reproducing information stored on the information recording medium according to claim 1, the reproduction apparatus comprising:

- a reading section for reading the plurality of pieces of audio data and the plurality of pieces of still picture data from the information recording medium; and
- a reproduction control section for controlling a display order of the plurality of pieces of still picture data to be displayed simultaneously with the reproduction of the plurality of pieces of audio data in accordance with the reproduction control information,

wherein the reproduction control section specifies the specified still picture data among the plurality of pieces of still picture data in accordance with the specified still picture information.

4. A reproduction apparatus according to claim 3, wherein the specified still picture information represents that specified still picture data is not included in the plurality of pieces of still picture data.

5. A reproduction method for reproducing information stored on the information recording medium according to claim 1, the method comprising the steps of:

- reading the plurality of pieces of audio data and the plurality of pieces of still picture data from the information recording medium; and
- controlling a display order of the plurality of pieces of still picture data to be displayed simultaneously with the reproduction of the plurality of pieces of audio data in accordance with the reproduction control information, wherein the step of controlling includes the step of specifying the specified still picture data among the plurality of pieces of still picture data in accordance with the specified still picture information.

6. A reproduction method according to claim 5, wherein the specified still picture information represents that specified still picture data is not included in the plurality of pieces of still picture data.

7. A recording medium having recorded thereon a program that when executed by a processor in a reproduction apparatus causes the reproduction apparatus to execute steps in a reproduction method for reproducing information stored on the information recording medium according to claim 1, wherein the reproduction method includes the steps of:

- reading the plurality of pieces of audio data and the plurality of pieces of still picture data from the information recording medium; and
- controlling a display order of the plurality of pieces of still picture data to be displayed simultaneously with the reproduction of the plurality of pieces of audio data in accordance with the reproduction control information,

31

wherein the step of controlling includes the step of specifying the specified still picture data among the plurality of pieces of still picture data in accordance with the information.

8. A recording medium according to claim 7, wherein the specified still picture information represents that specified still picture data is not included in the plurality of pieces of still picture data.

9. A recording medium having recorded thereon a program that when executed by a processor in a reproduction apparatus causes the reproduction apparatus to execute steps in a reproduction method for reproducing information stored on an information recording medium recorded by a recording method comprising storing a plurality of pieces of audio data for at least one audio program in an audio data storage area on the information recording medium; storing a plurality of pieces of still picture data in a still picture data storage area on the information recording medium; and storing reproduction control information in a management area on the information recording medium which defines a reproduction order of the plurality of pieces of audio data and a display order of the plurality of pieces of still picture data to be displayed simultaneously with the reproduction of the plurality of pieces of audio data, the reproduction order of the plurality of pieces of audio data and the display order

32

of the plurality of pieces of still picture data being defined separately by the reproduction control information, wherein the reproduction control information has specified still picture information indicating specified still picture data to be independently displayed by a specified operation regardless of the display order of the plurality of pieces of still picture data,

wherein the reproduction method includes the steps of: reading the plurality of pieces of audio data and the plurality of pieces of still picture data from the information recording medium; and

controlling a display order of the plurality of pieces of still picture data to be displayed simultaneously with the reproduction of the plurality of pieces of audio data in accordance with the reproduction control information, wherein the step of controlling includes the step of specifying the specified still picture data among the plurality of pieces of still picture data in accordance with the information.

10. A recording medium according to claim 9, wherein the specified still picture information represents that specified still picture data is not included in the plurality of pieces of still picture data.

* * * * *