

US007294942B2

(12) **United States Patent**
Lee et al.

(10) **Patent No.:** **US 7,294,942 B2**
(45) **Date of Patent:** **Nov. 13, 2007**

(54) **OUTER ROTOR TYPE MOTOR FOR DRUM TYPE WASHING MACHINE AND METHOD FOR FABRICATING THE SAME**

(75) Inventors: **Deug Hee Lee**, Changwon-si (KR);
Seung Bong Choi, Changwon-si (KR);
Byung Hwan Ahn, Changwon-si (KR)

(73) Assignee: **LG Electronics Inc.**, Seoul (KR)

(*) Notice: Subject to any disclaimer, the term of this patent is extended or adjusted under 35 U.S.C. 154(b) by 0 days.

(21) Appl. No.: **11/008,407**

(22) Filed: **Dec. 10, 2004**

(65) **Prior Publication Data**

US 2005/0127775 A1 Jun. 16, 2005

(30) **Foreign Application Priority Data**

Dec. 10, 2003 (KR) 10-2003-0089721
Dec. 10, 2003 (KR) 10-2003-0089722
Dec. 10, 2003 (KR) 10-2003-0089723
Dec. 10, 2003 (KR) 10-2003-0089724
Dec. 10, 2003 (KR) 10-2003-0089726

(51) **Int. Cl.**

H02K 3/34 (2006.01)
H02K 1/18 (2006.01)
D09F 37/30 (2006.01)

(52) **U.S. Cl.** **310/43**; 310/216; 310/217;
310/254; 68/140; 68/12.16

(58) **Field of Classification Search** 310/43,
310/216, 217, 67 R, 51, 254, 258, 259, 215;
68/140, 12.16

See application file for complete search history.

(56) **References Cited**

U.S. PATENT DOCUMENTS

1,669,113 A * 5/1928 Wood 310/258

4,365,180 A * 12/1982 Licata et al. 310/216
5,038,460 A 8/1991 Ide et al.
5,907,206 A 5/1999 Shiga et al.
6,049,930 A * 4/2000 Hisano et al. 8/159
6,127,760 A * 10/2000 Nagasaki et al. 310/254
6,460,382 B1 * 10/2002 Kim et al. 68/140
2003/0146671 A1 * 8/2003 Diehl et al. 310/254
2004/0068857 A1 4/2004 Park et al.

FOREIGN PATENT DOCUMENTS

EP 1094144 A3 8/2001
EP 1428924 6/2004
GB 2275134 A 8/1994
JP 2000-116037 4/2000
JP 2000-166146 6/2000
JP 2003079080 A * 3/2003
KR 2001-37517 10/1999
KR 1999-81171 11/1999
KR 2001-37518 5/2001

OTHER PUBLICATIONS

Partial European Search Report EP 0425 7613, Apr. 8, 2005.

* cited by examiner

Primary Examiner—Karl Tamai
Assistant Examiner—David W. Scheuermann
(74) *Attorney, Agent, or Firm*—McKenna Long & Aldridge LLP

(57) **ABSTRACT**

Direct coupling type motor for drum type washing machine having a stator which can reduce material required for fabrication, and a weight after fabrication, simplify a fabrication process, and can be mounted on a fixing side, such as a tub or a bearing housing securely, and a rotor which can enhance rigidity an outer rotor and protect a surface of the outer rotor.

38 Claims, 25 Drawing Sheets

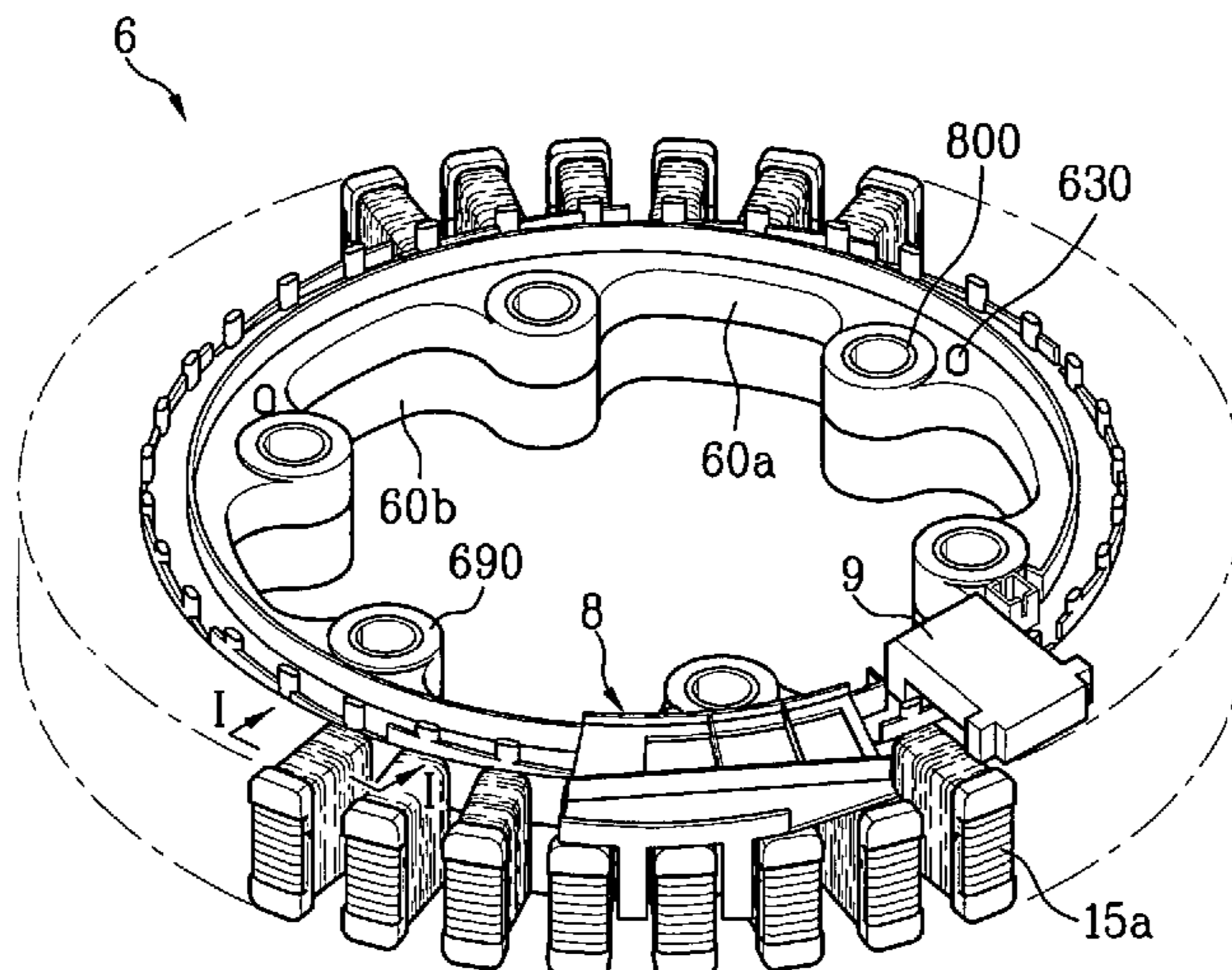

FIG. 1

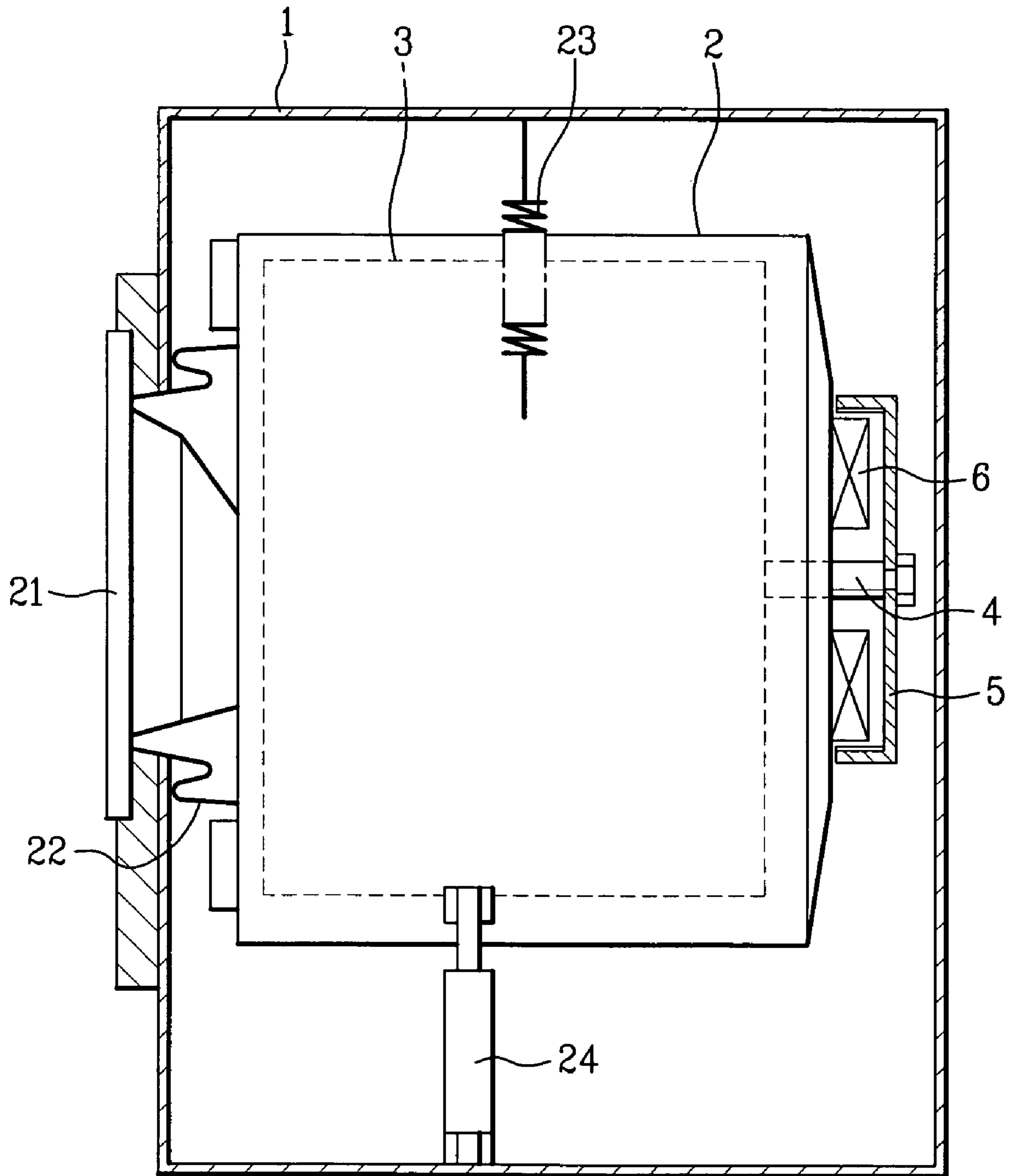

FIG. 2

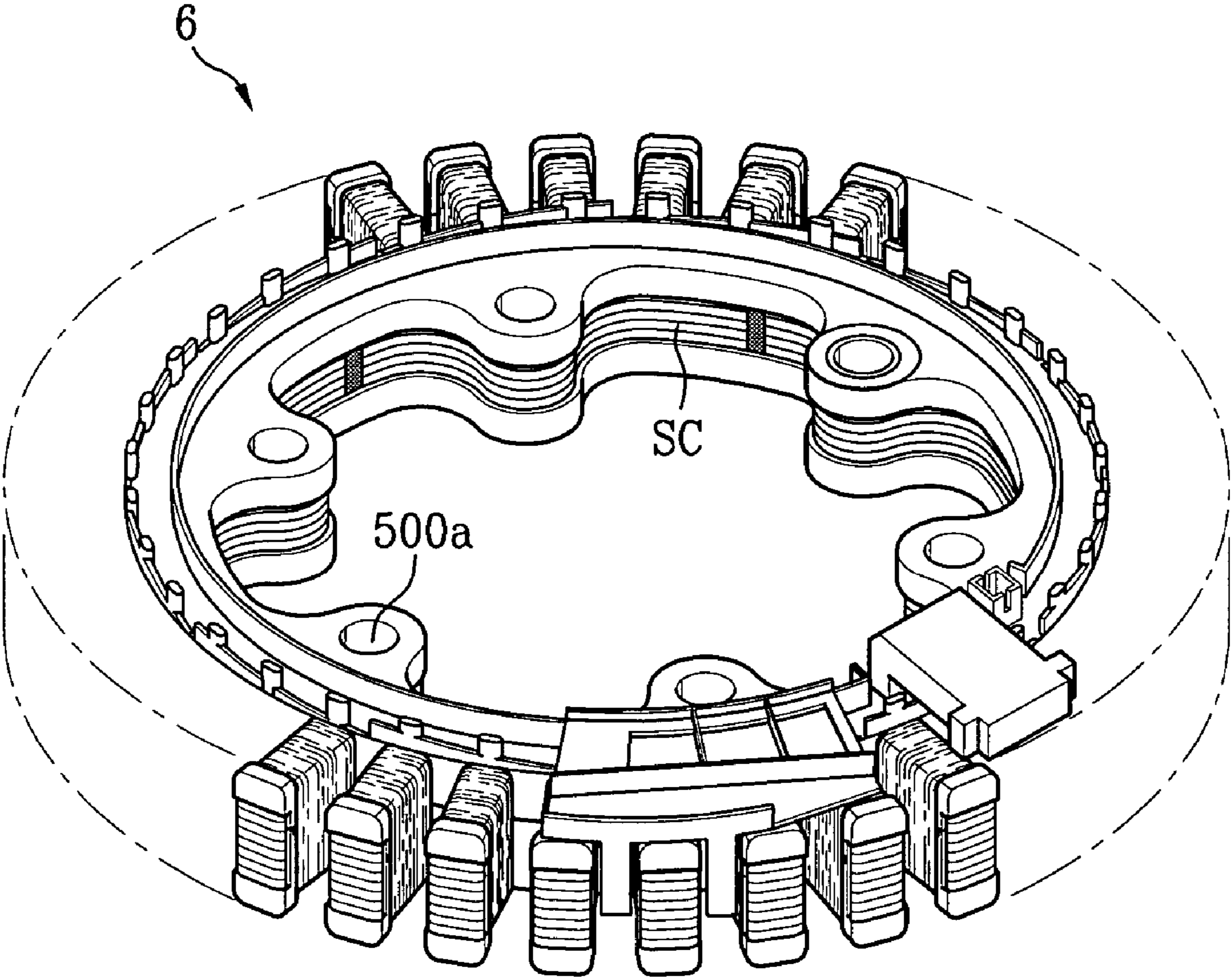

FIG. 3

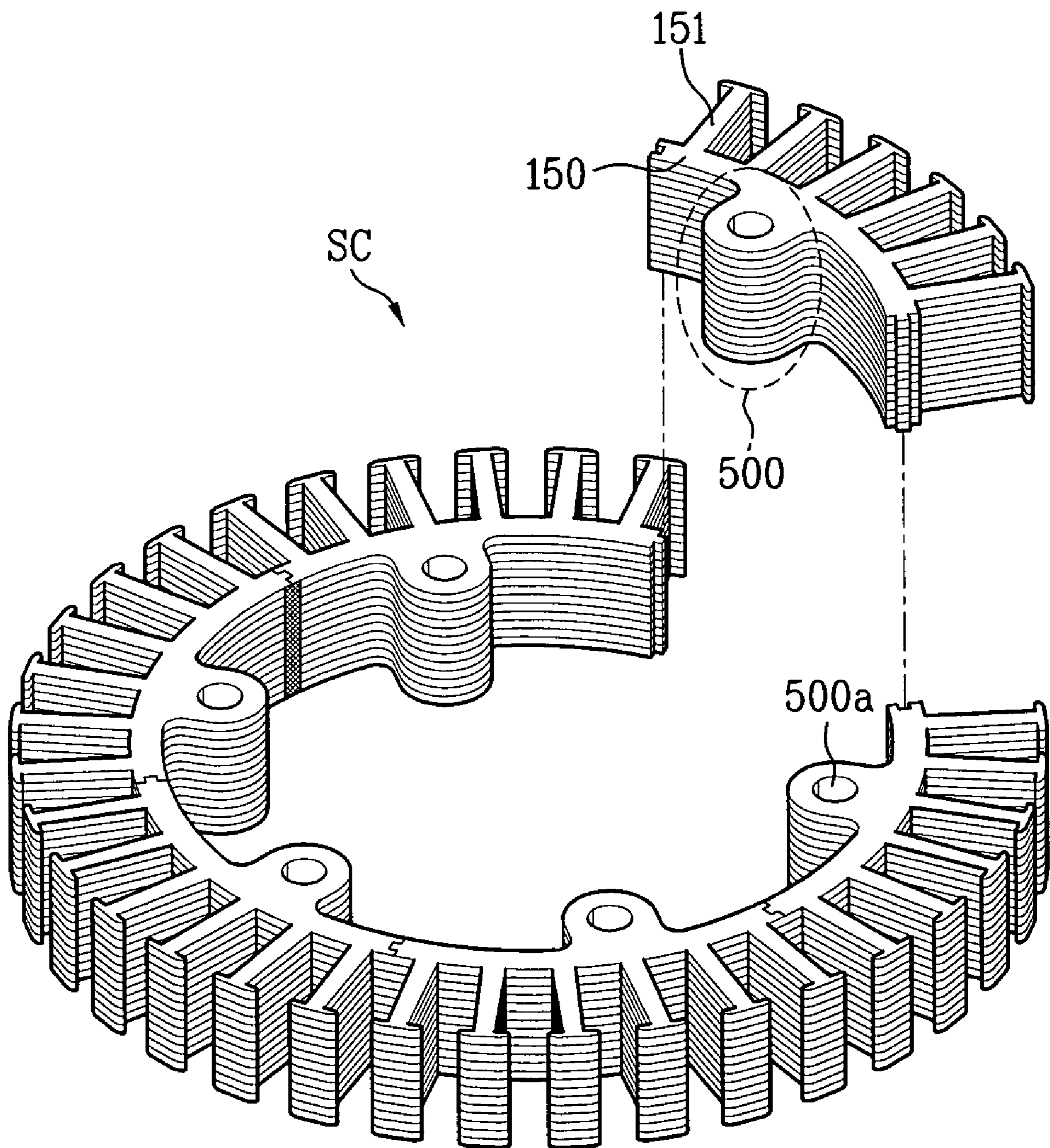

FIG. 4

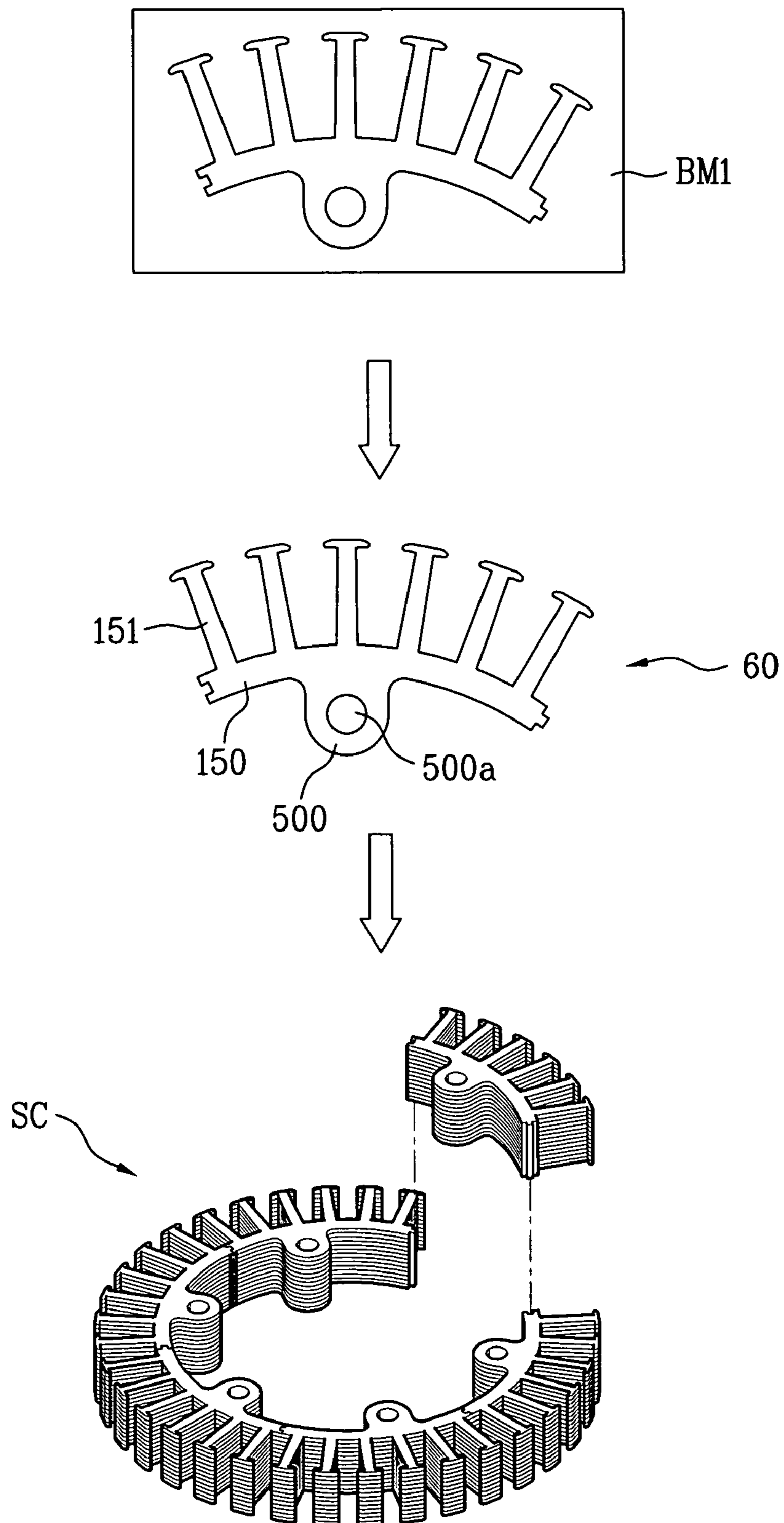

FIG. 5

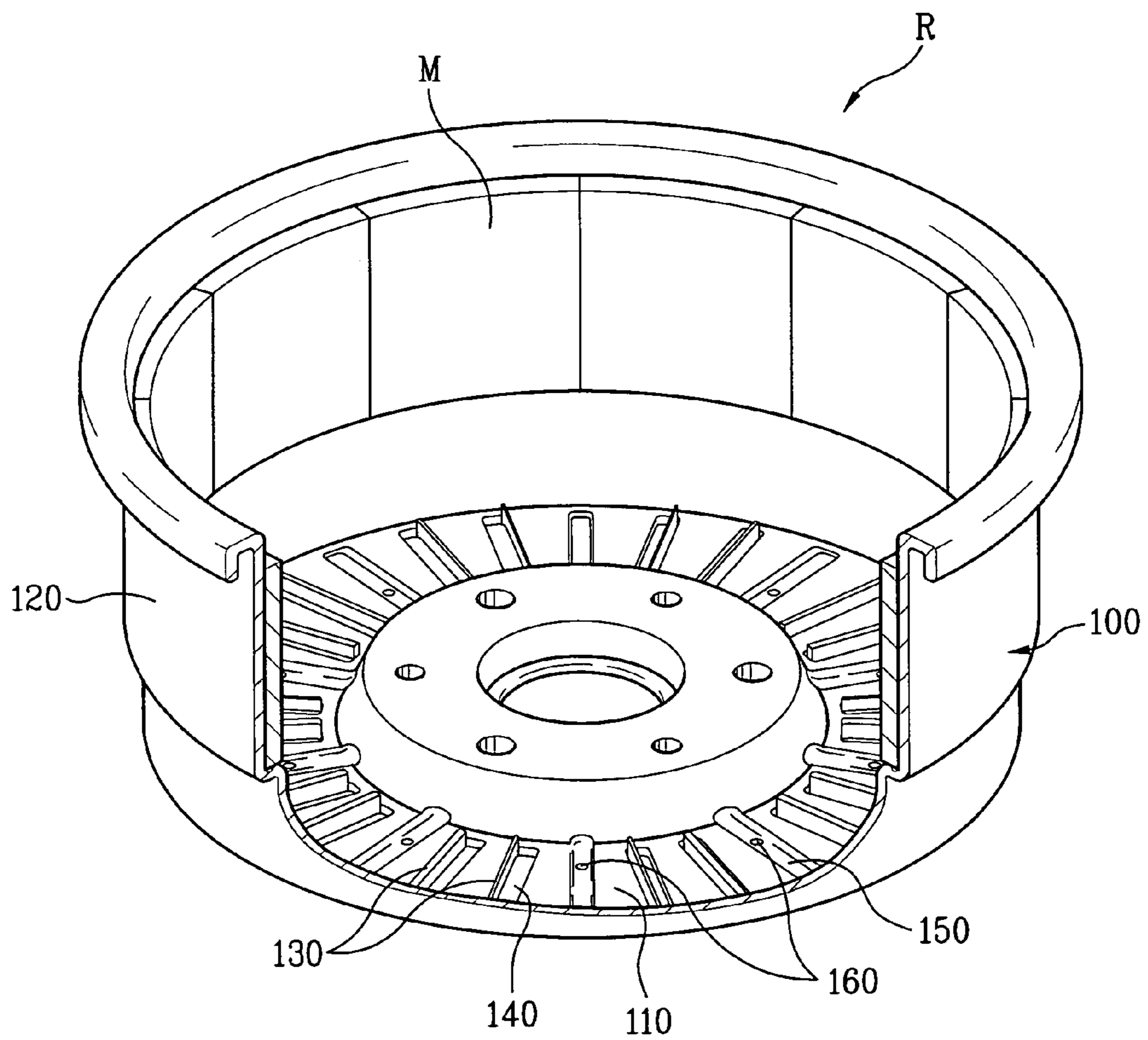

FIG. 6

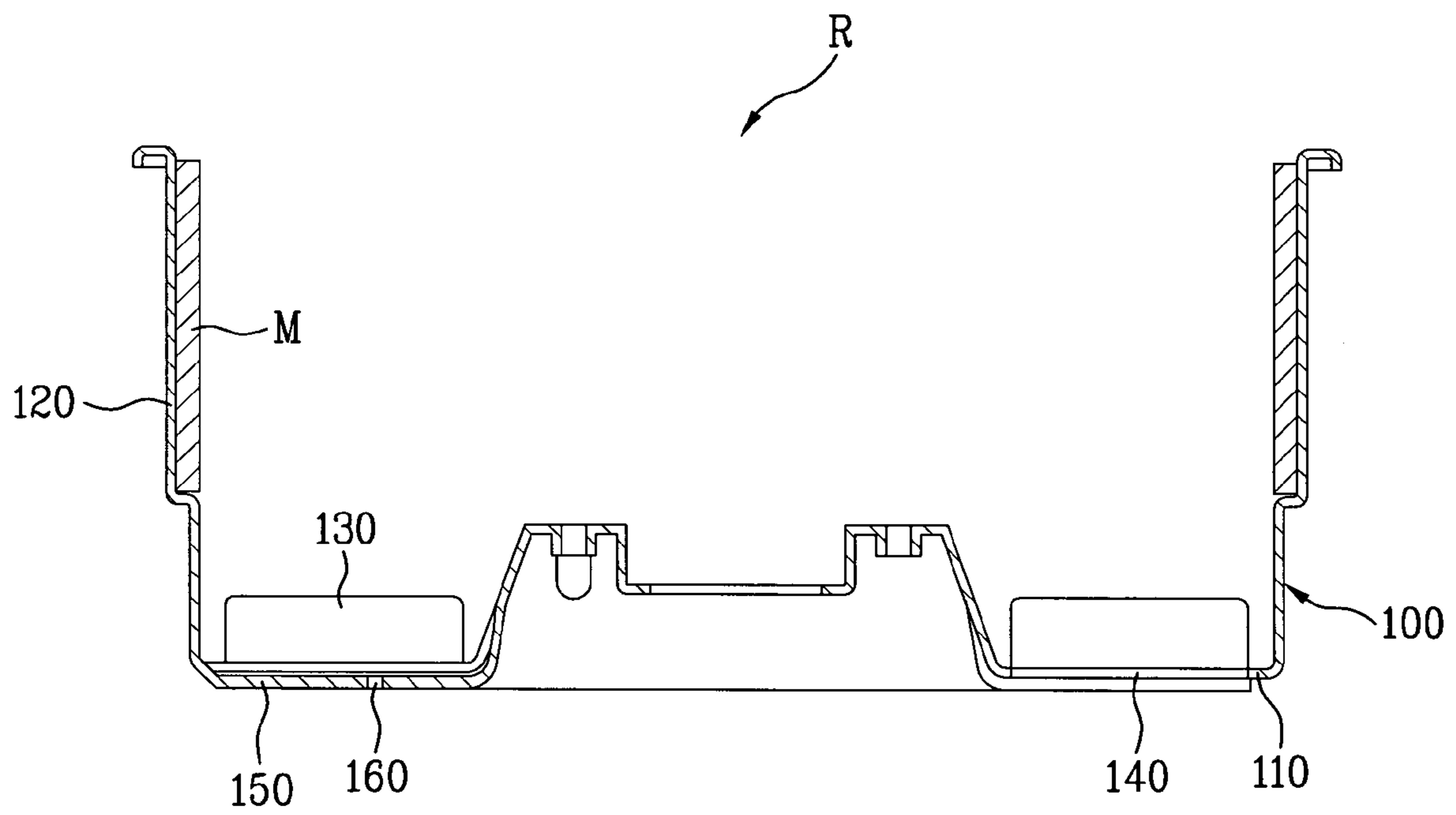

FIG. 7

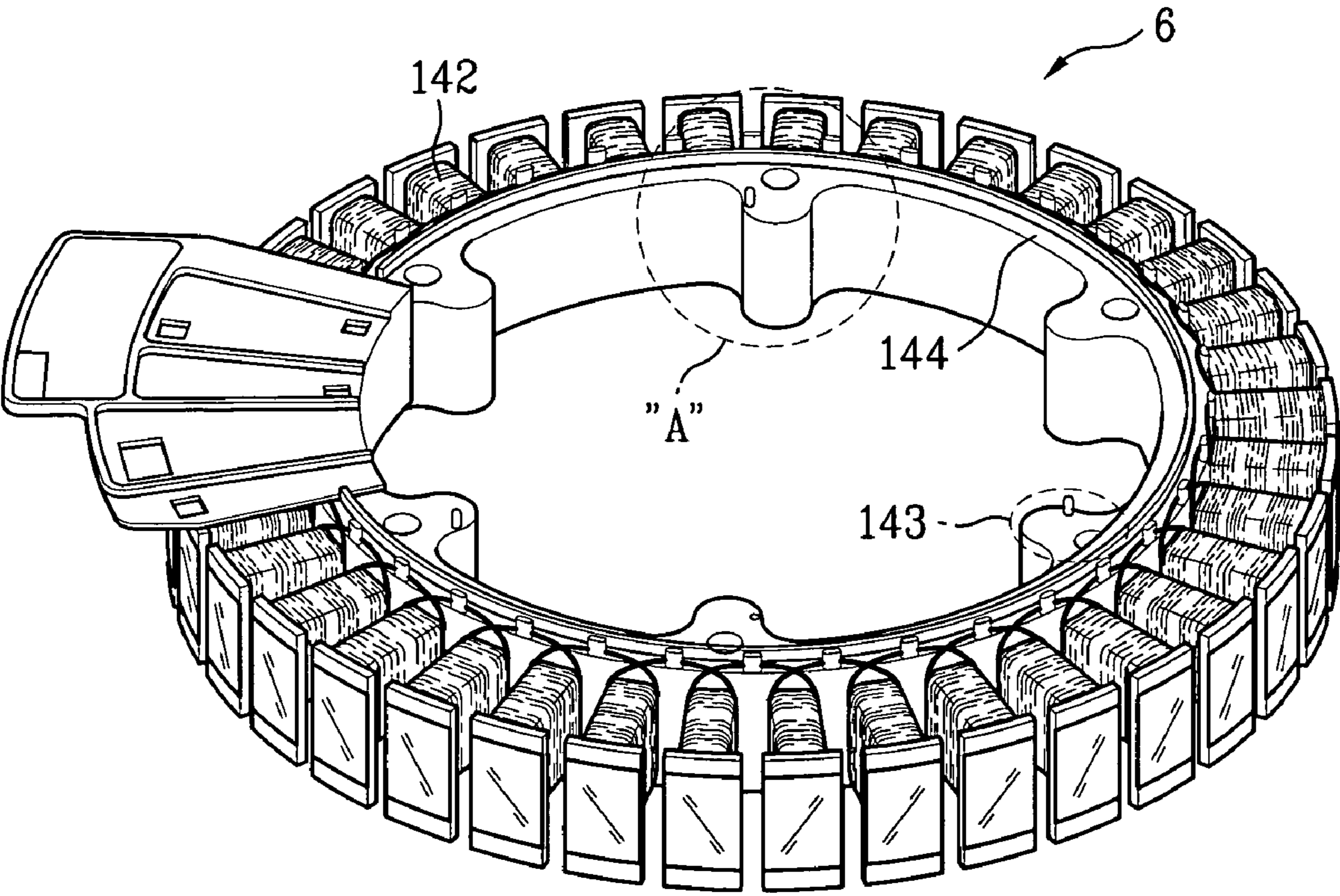

FIG. 8

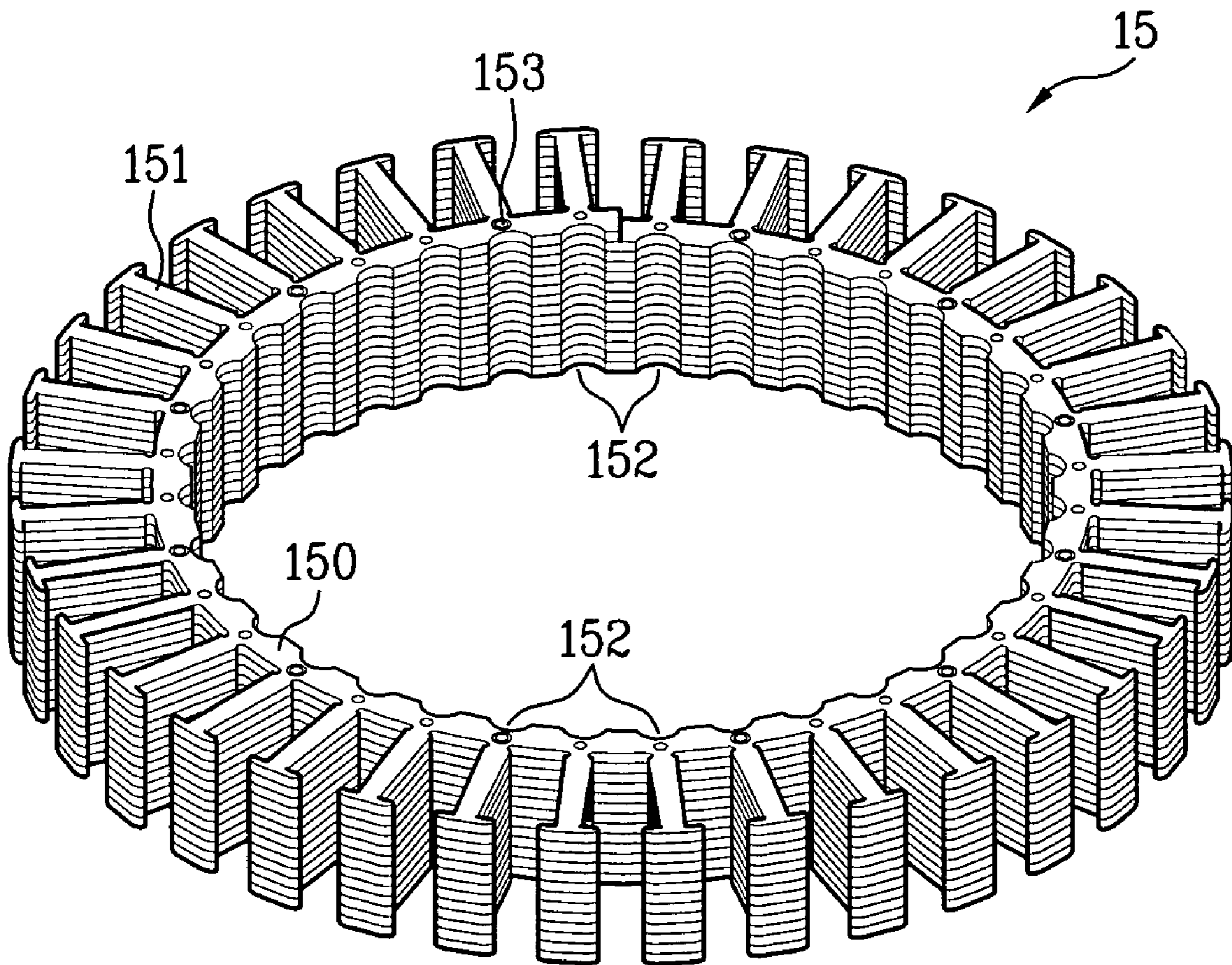

FIG. 9

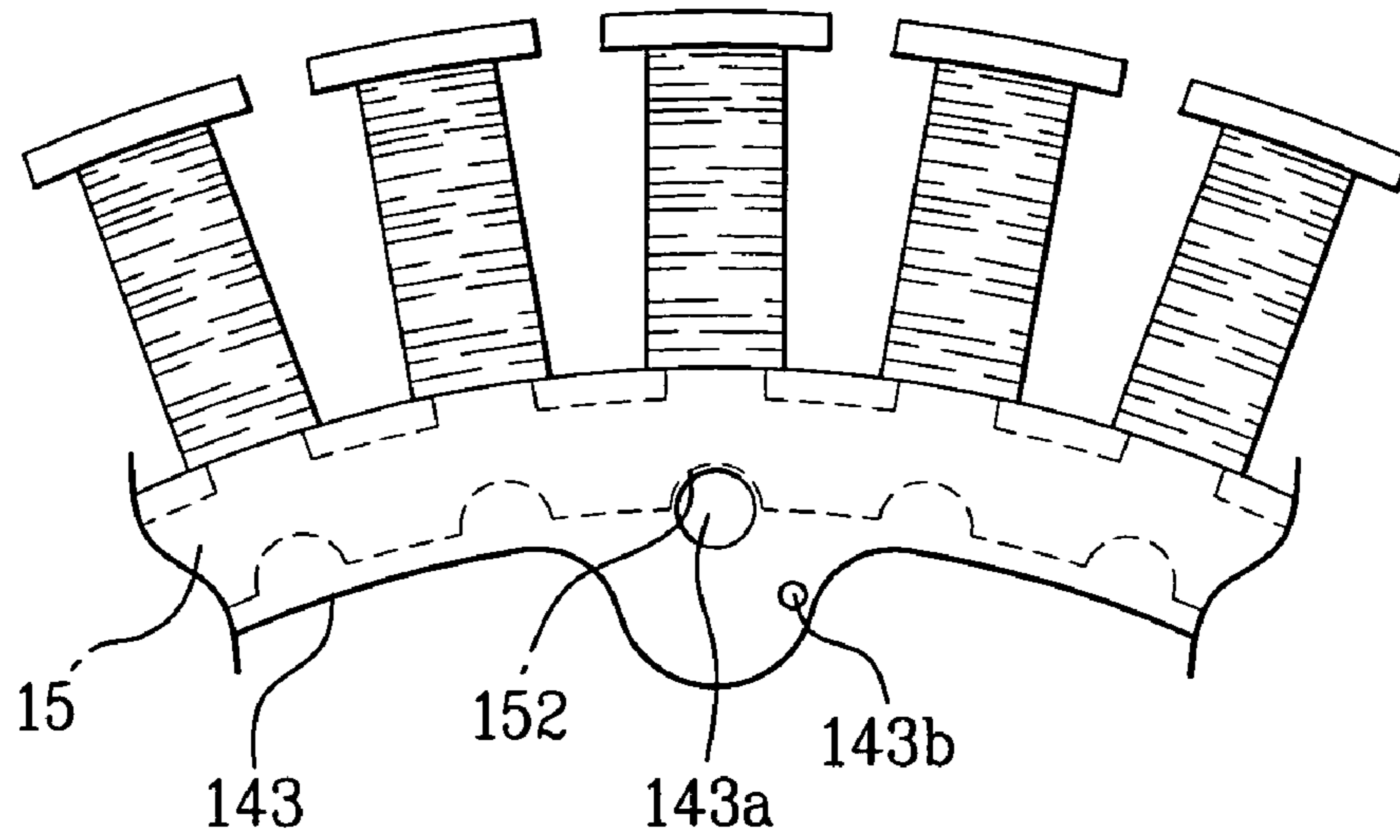

FIG. 10

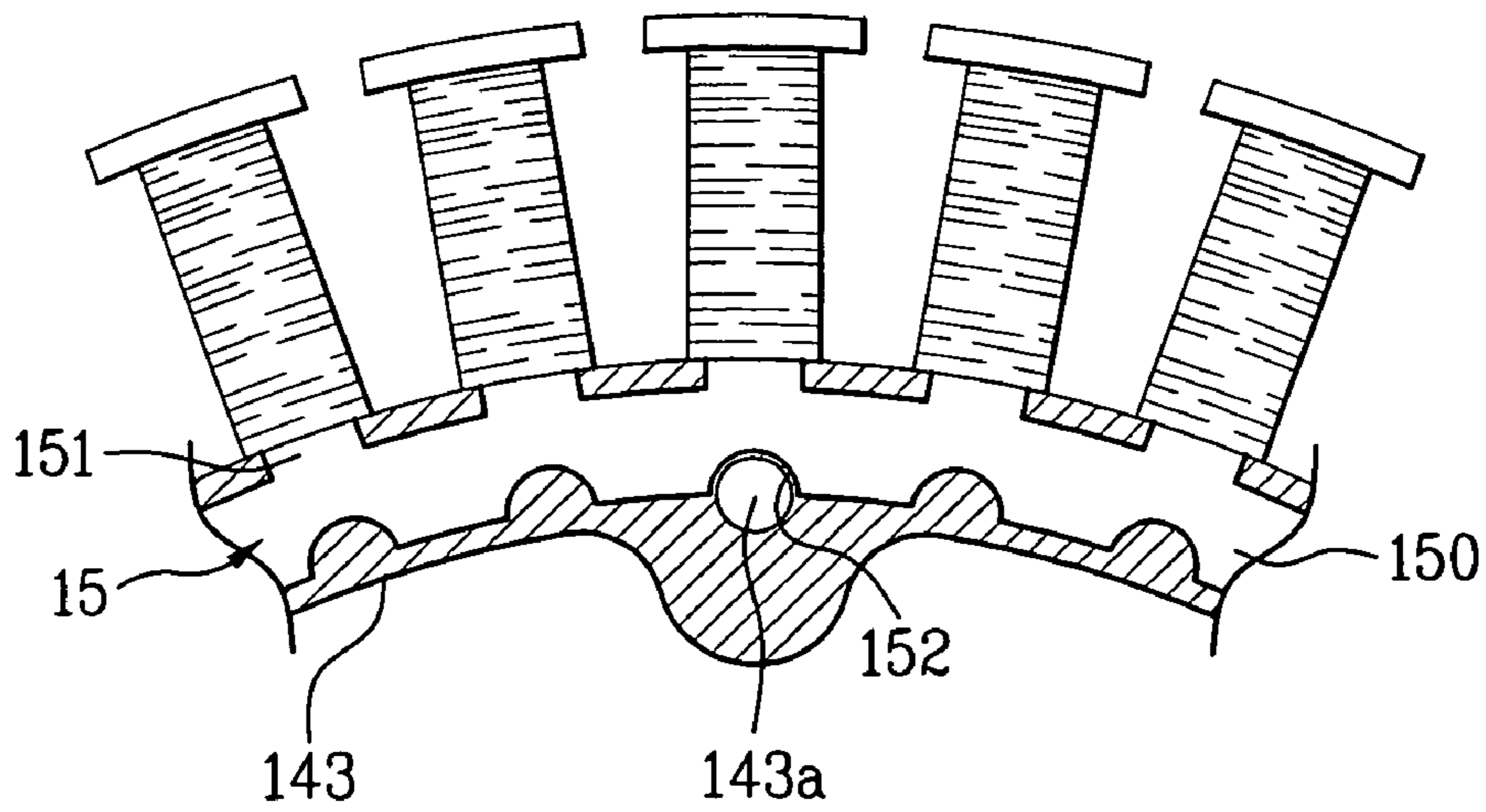

FIG. 11

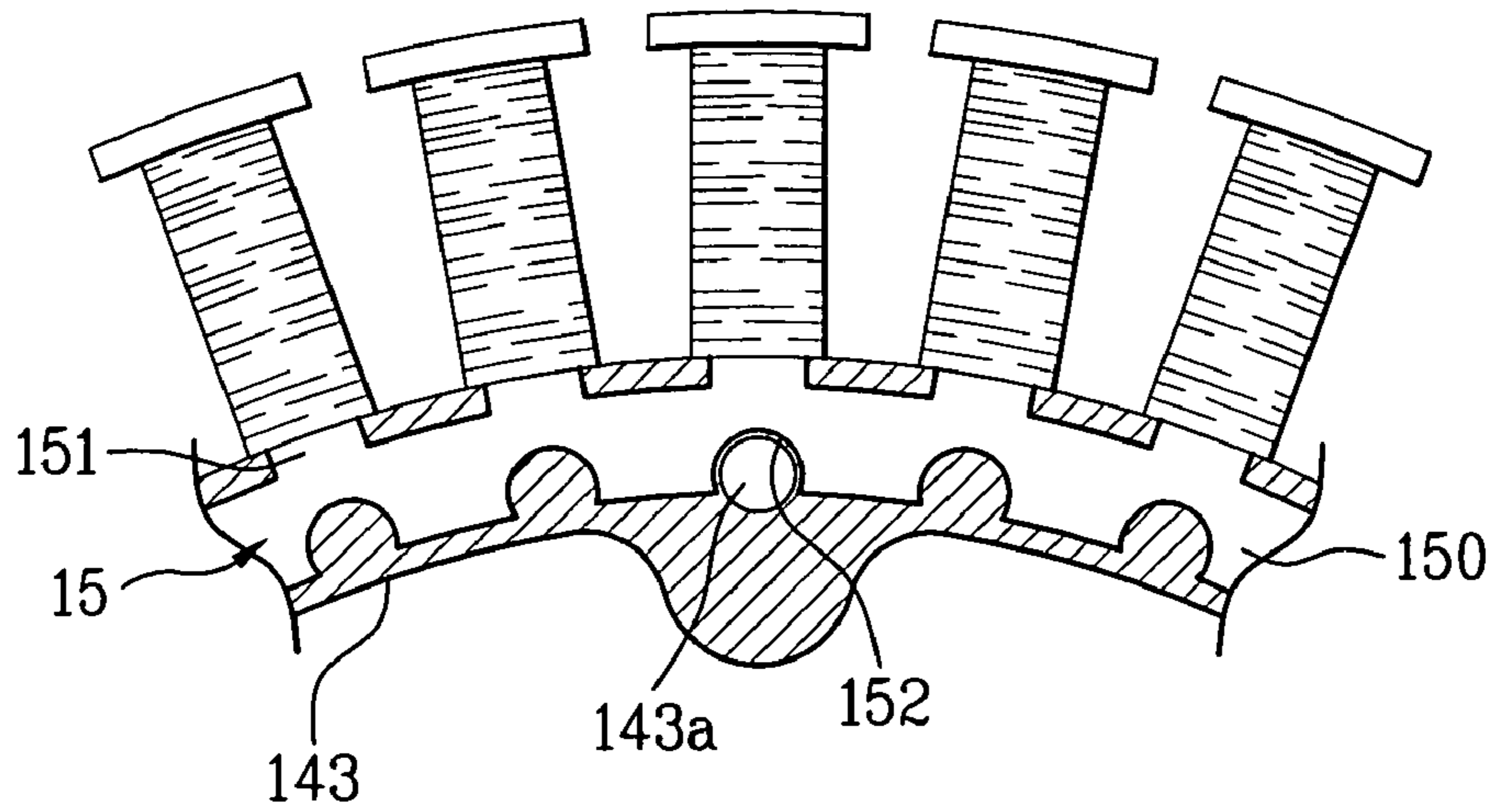

FIG. 12

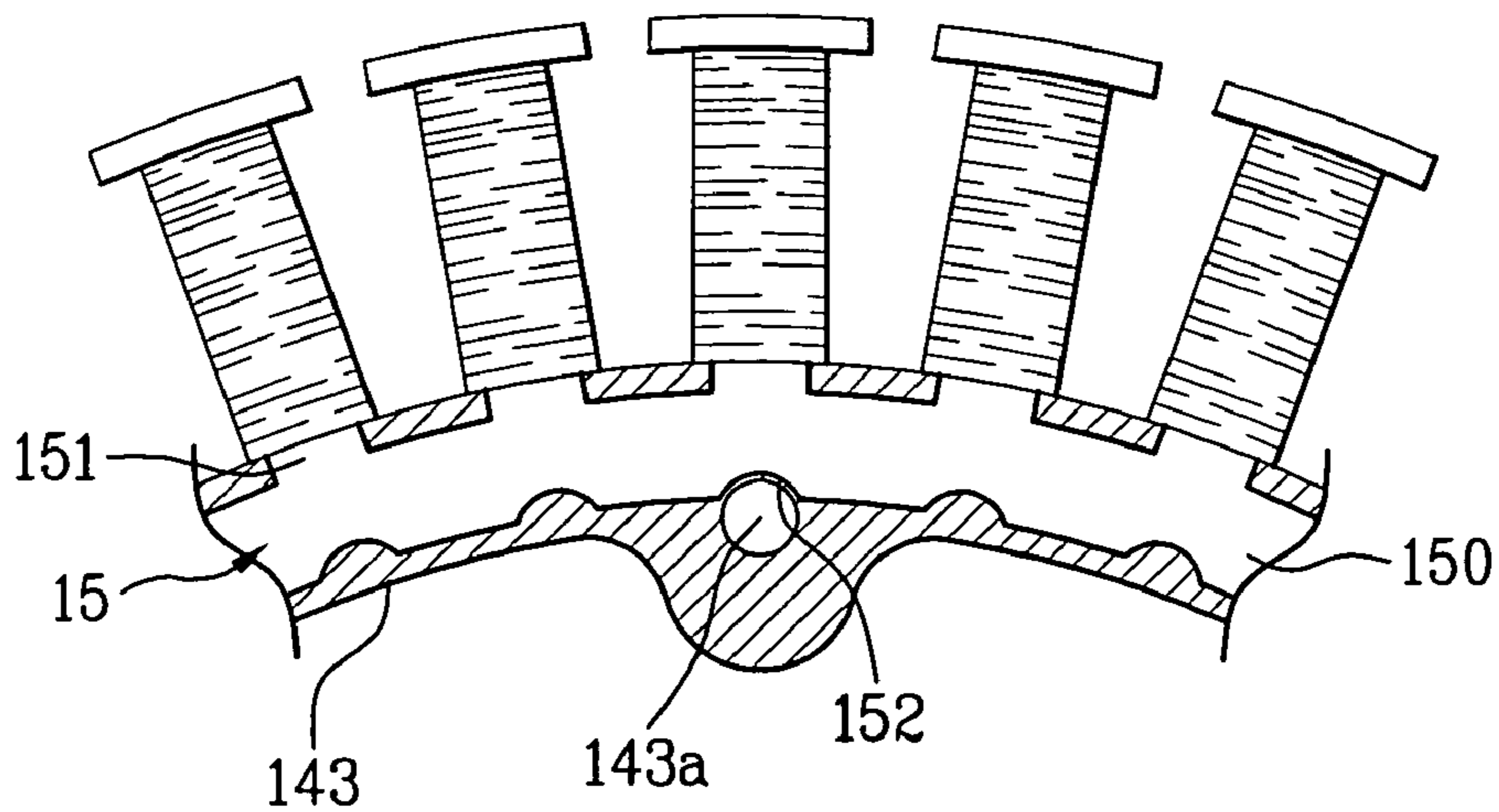

FIG. 13

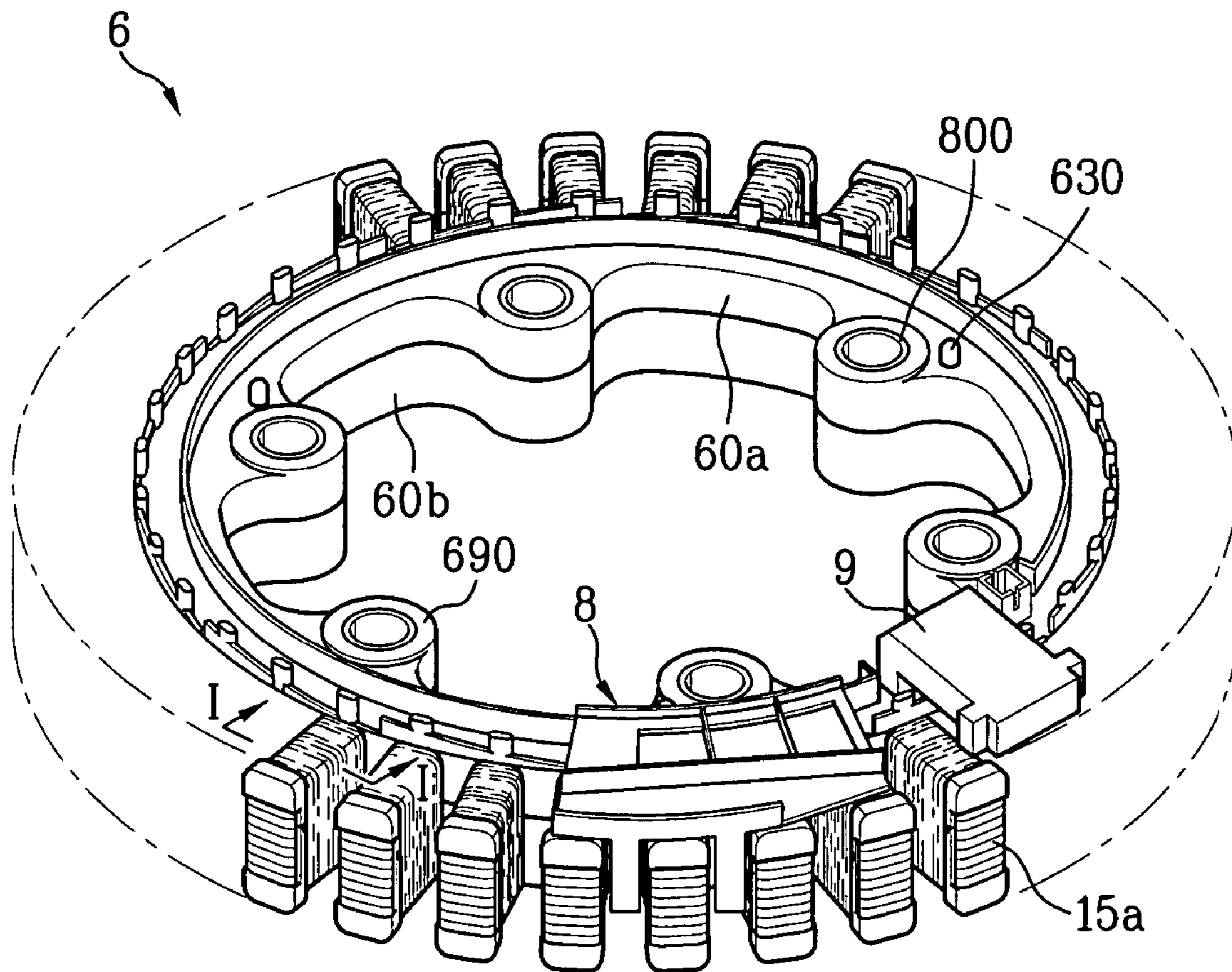

FIG. 14

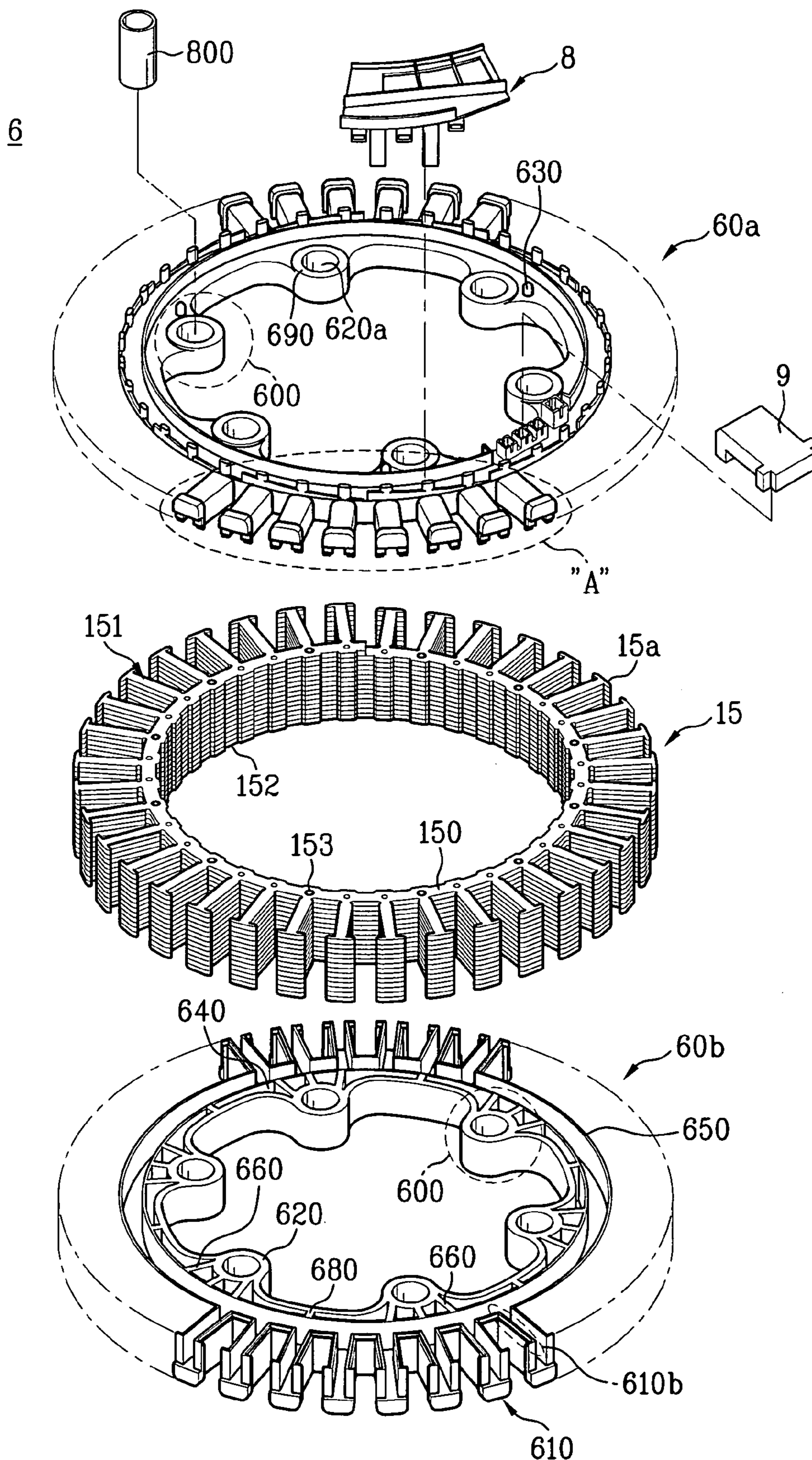

FIG. 15

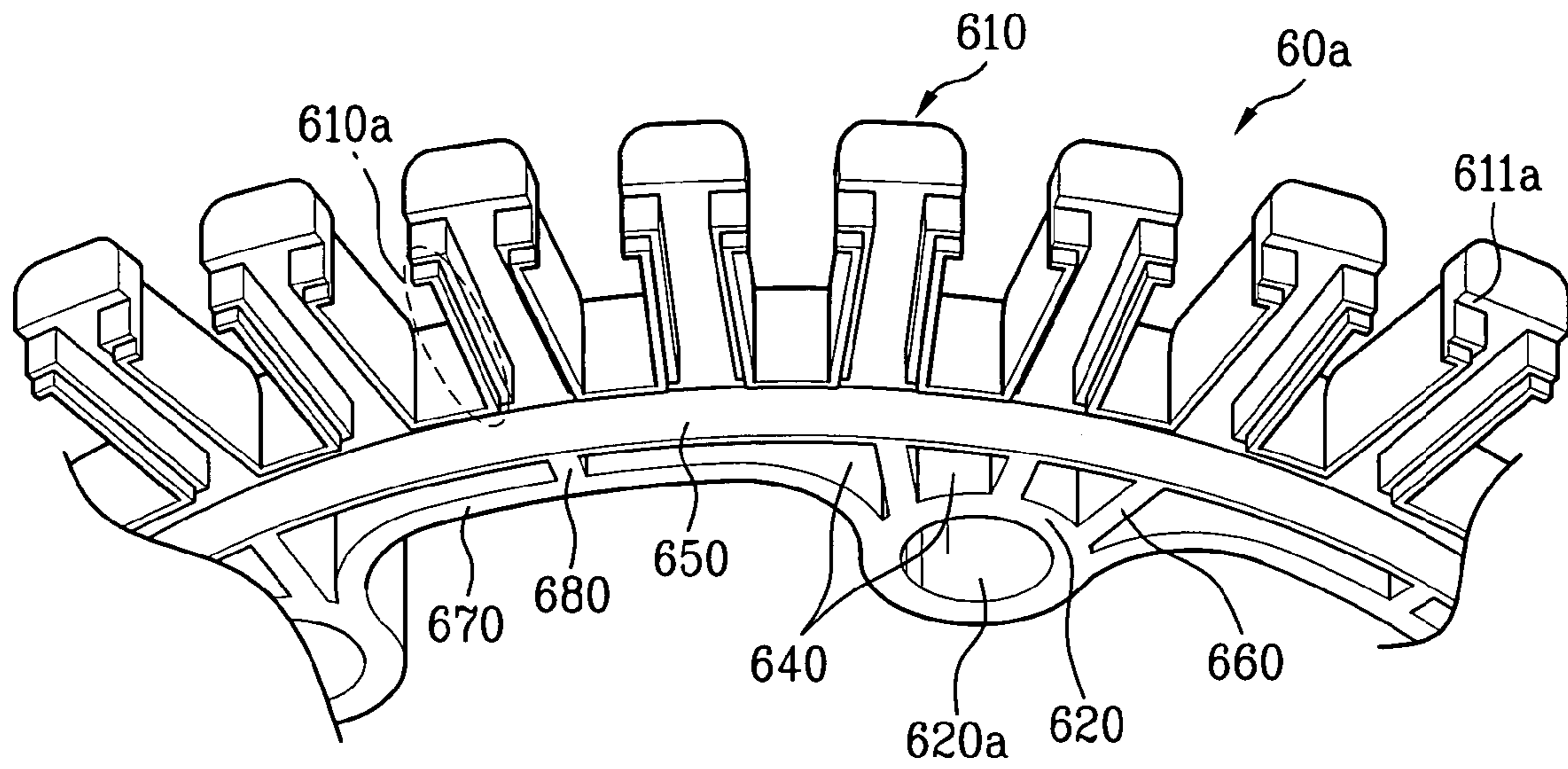

FIG. 16

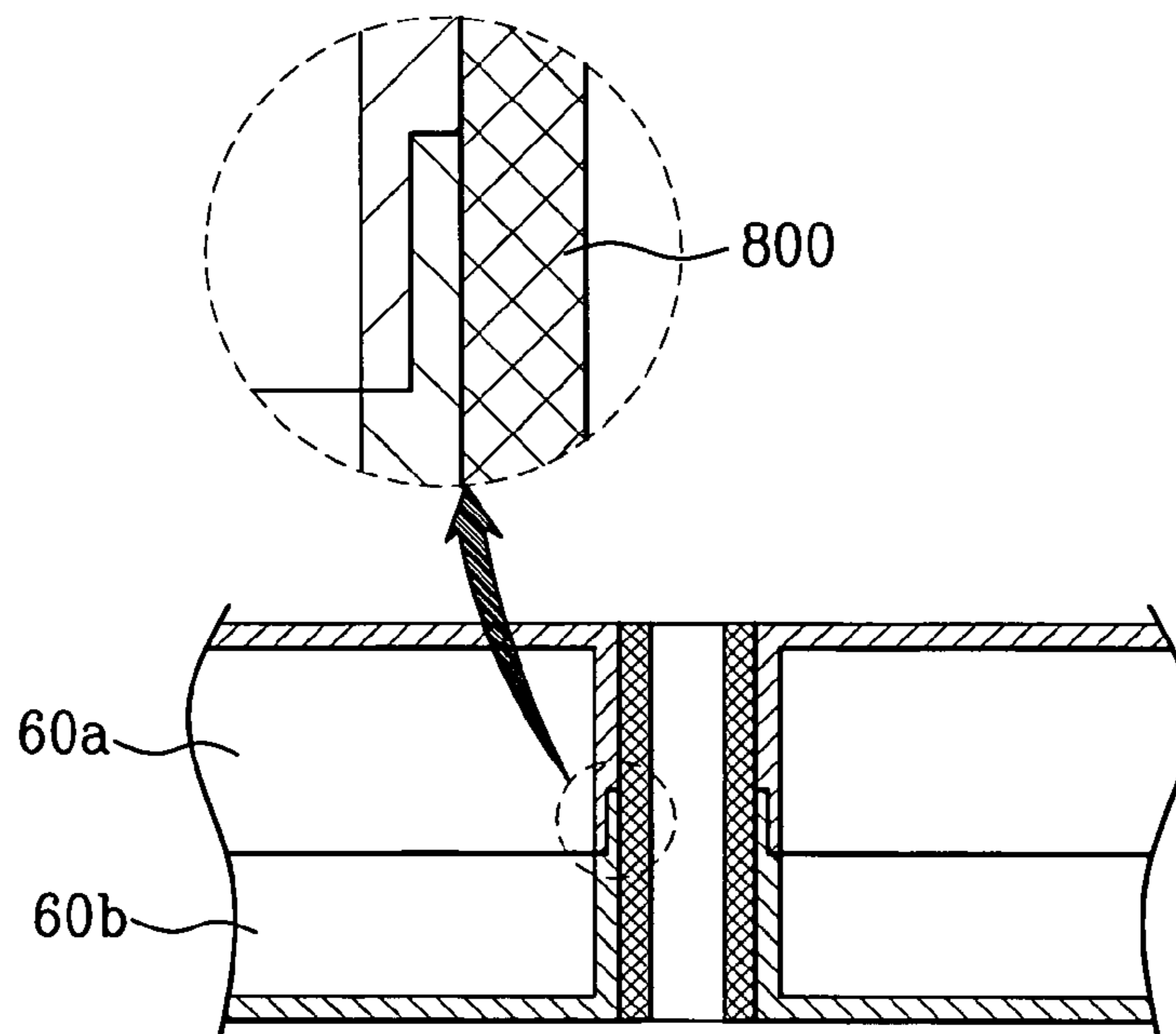

FIG. 17

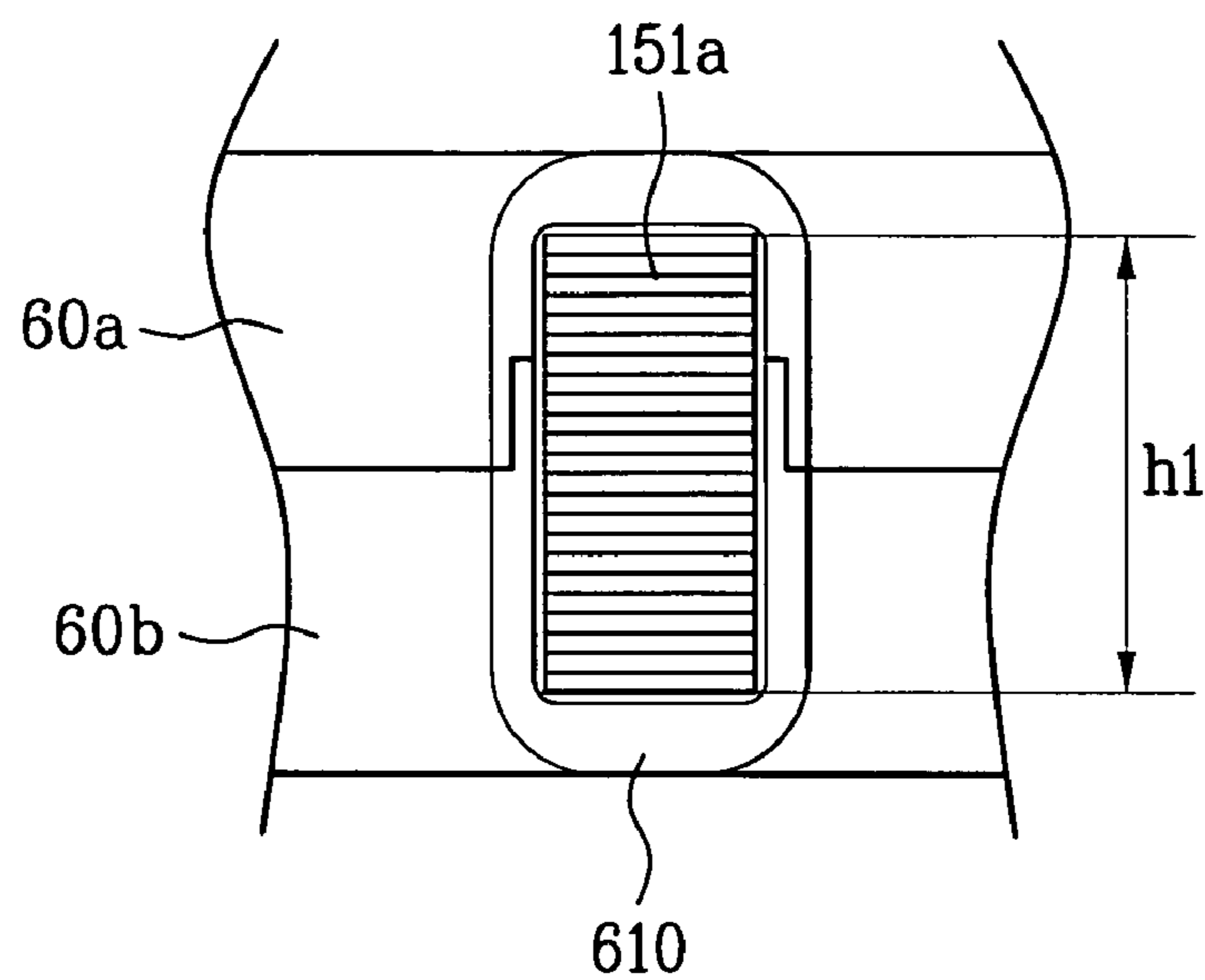

FIG. 18

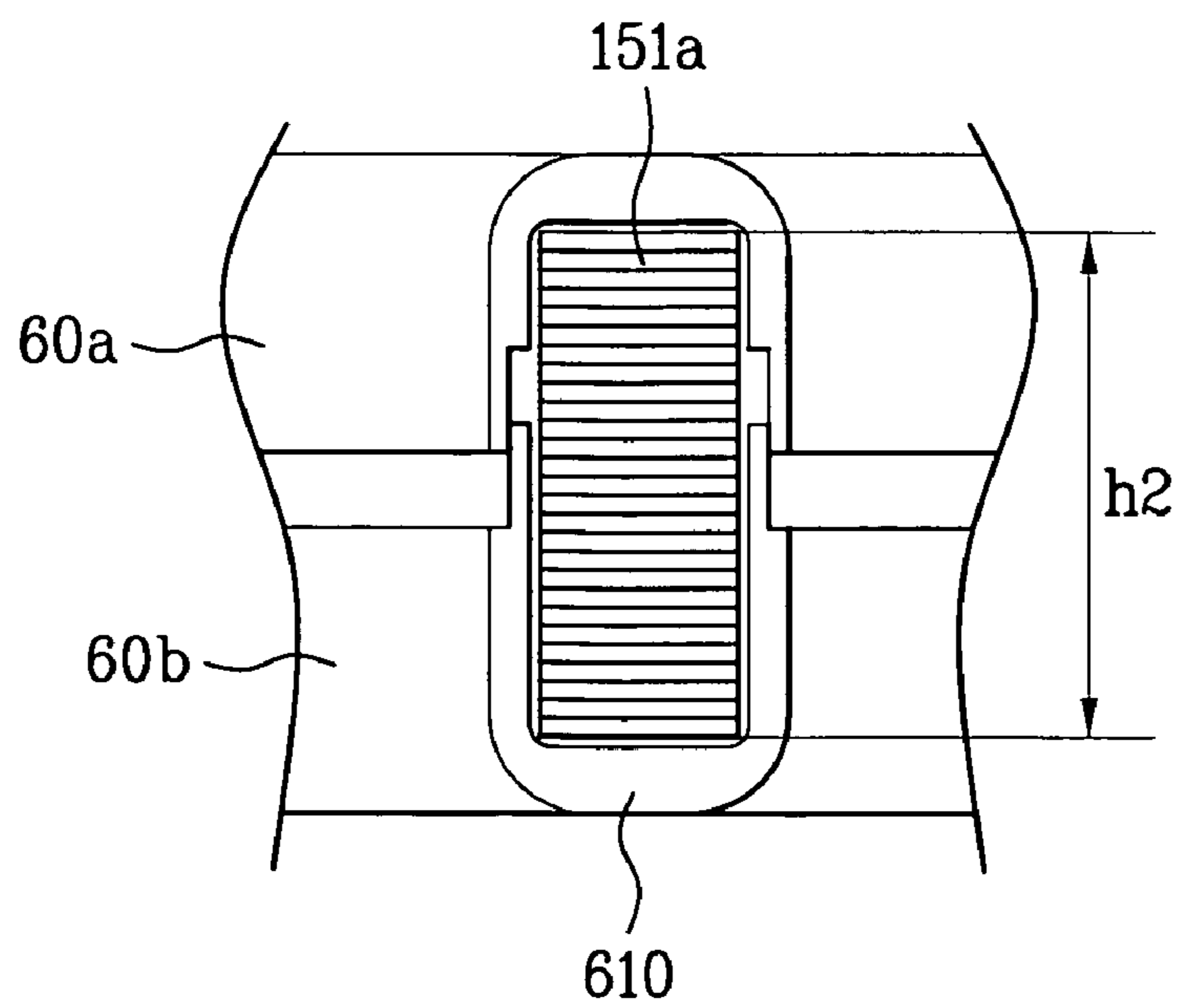

FIG. 19

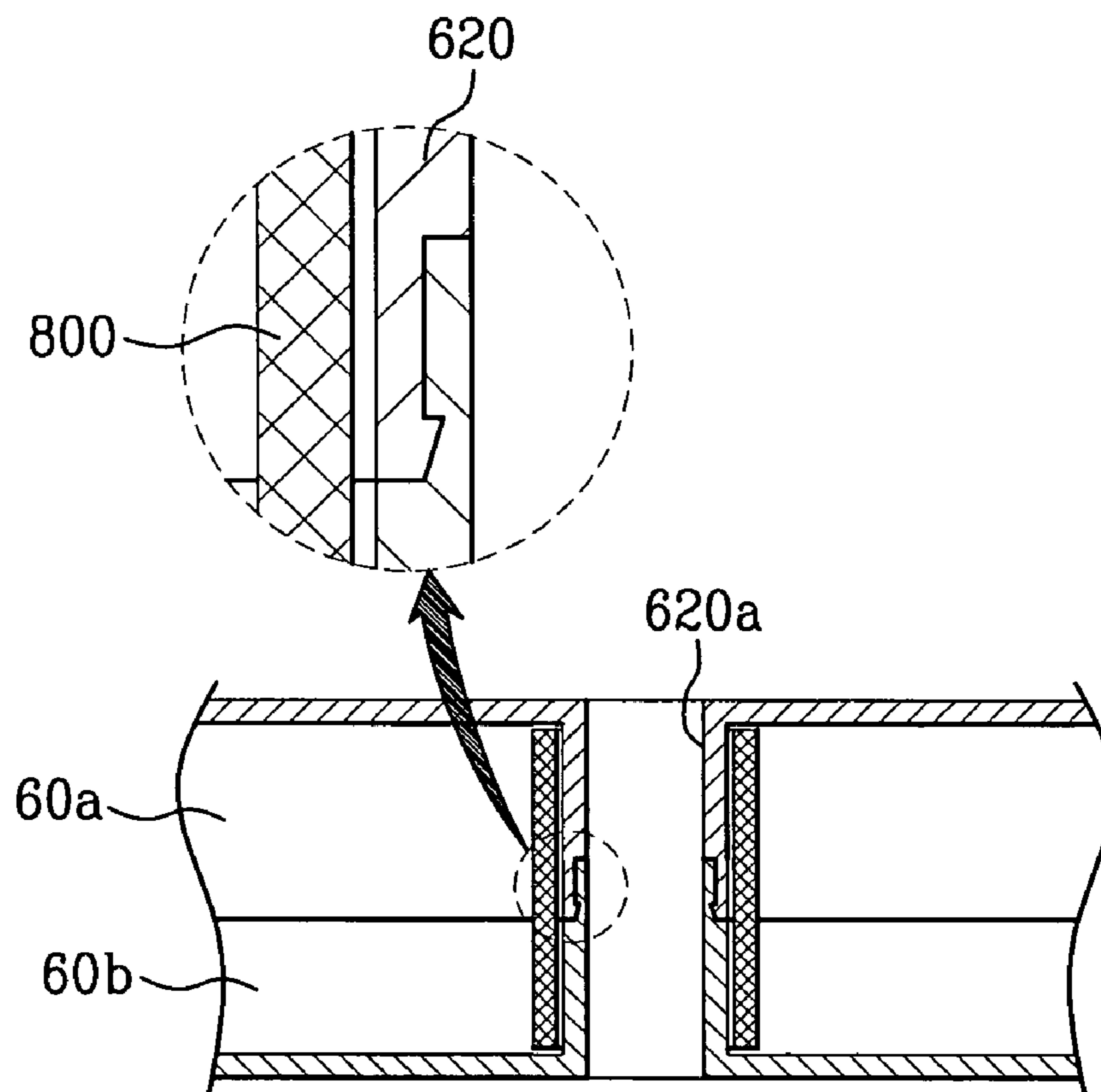

FIG. 20

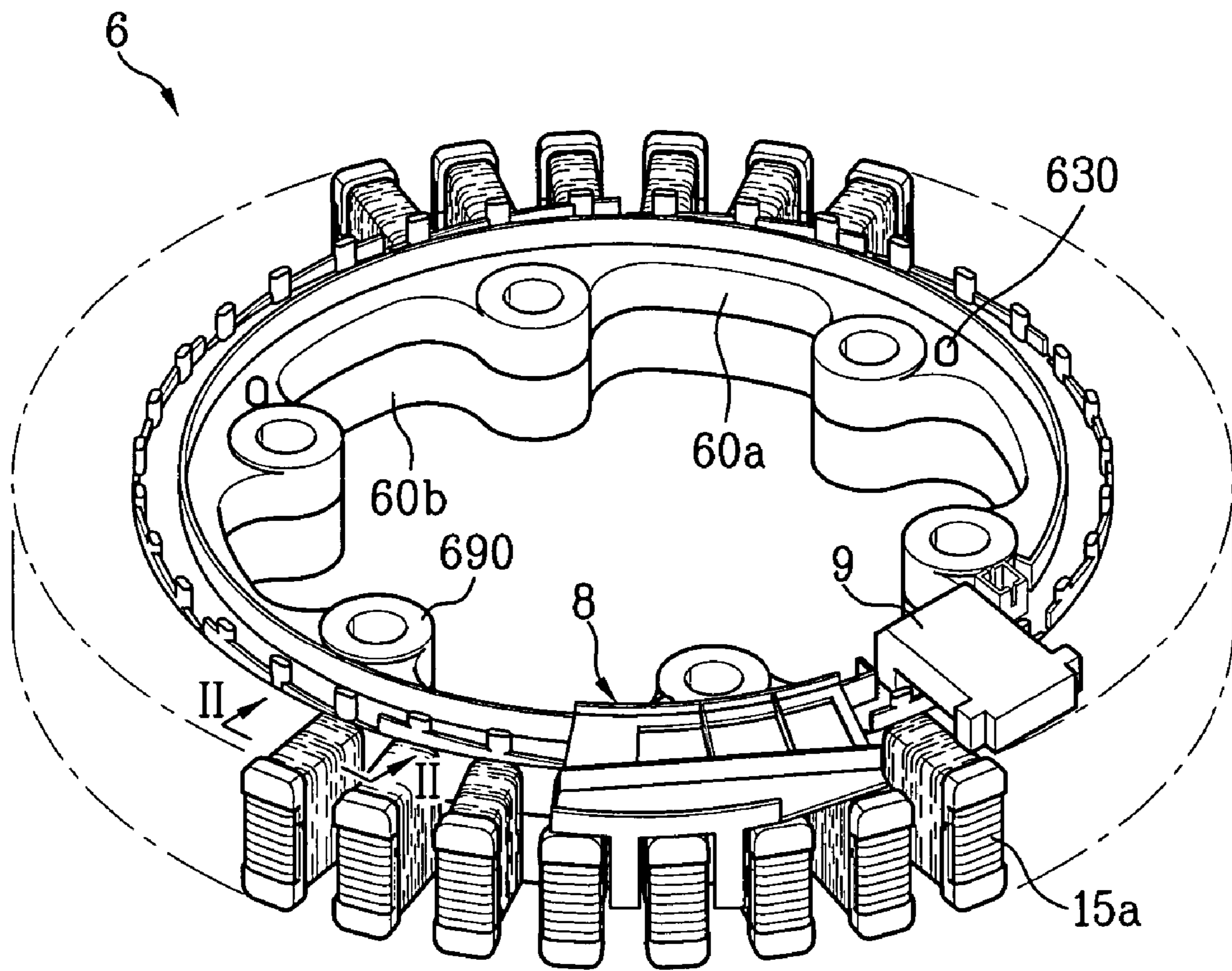

FIG. 21

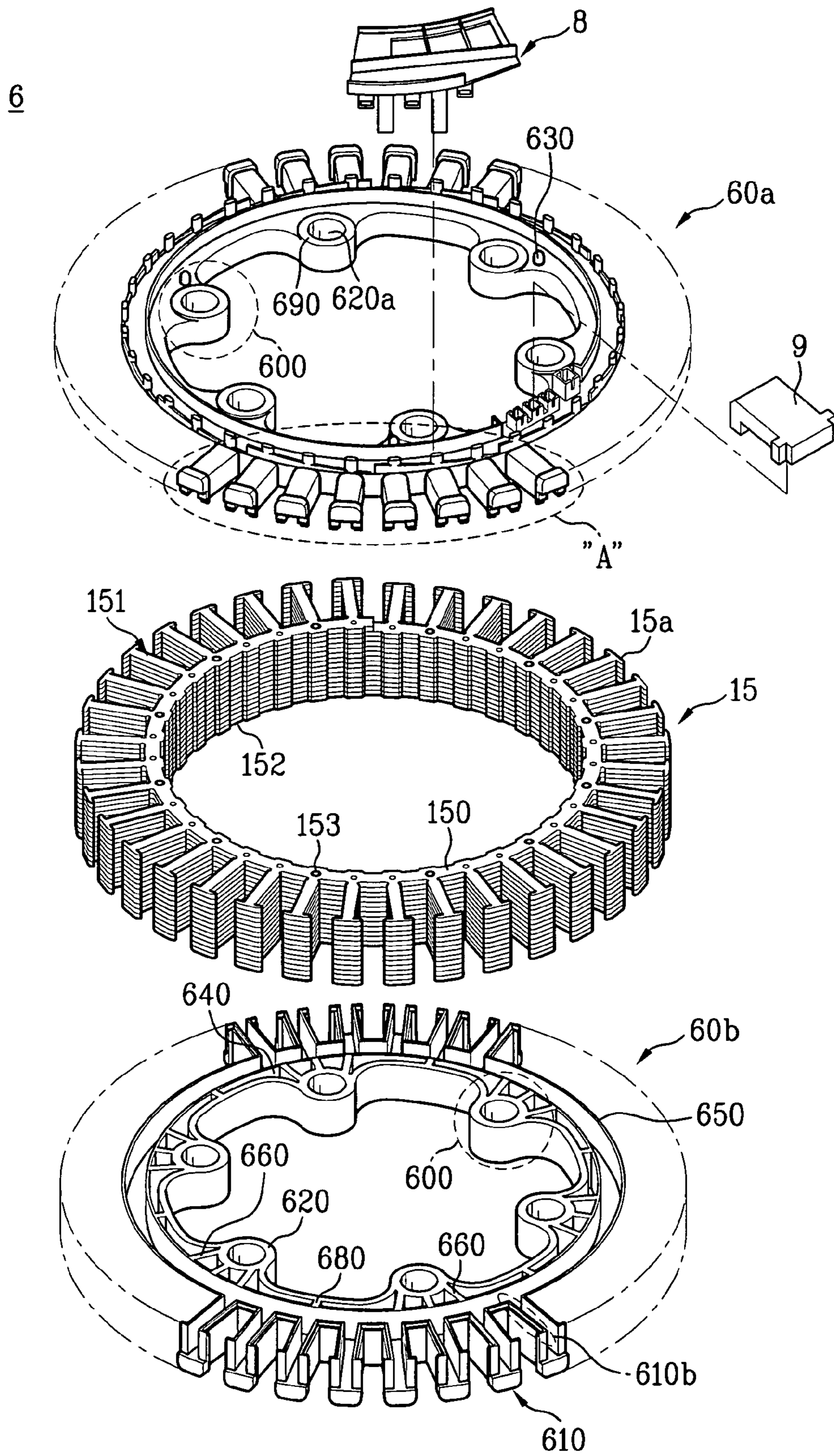

FIG. 22

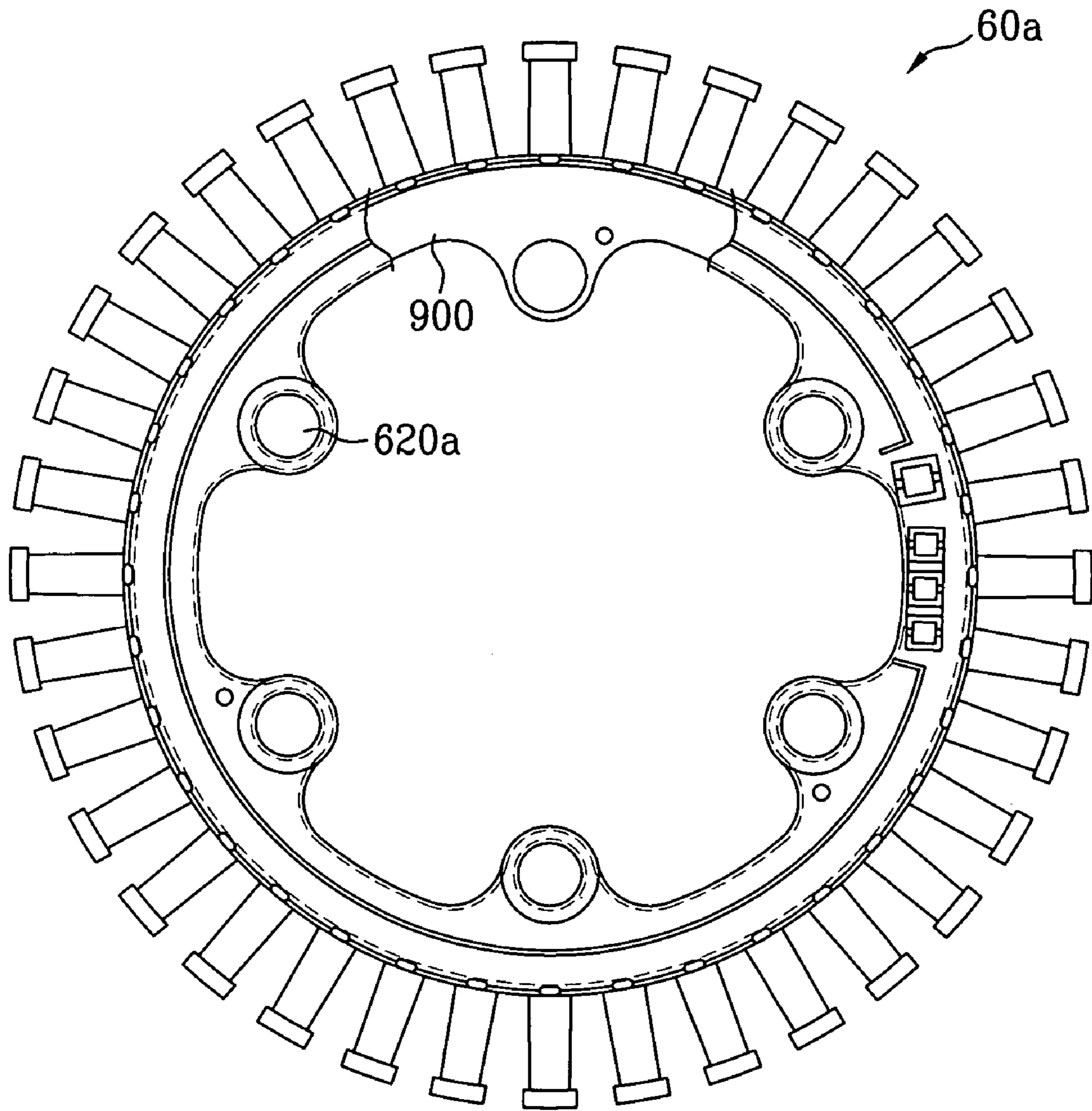

FIG. 23

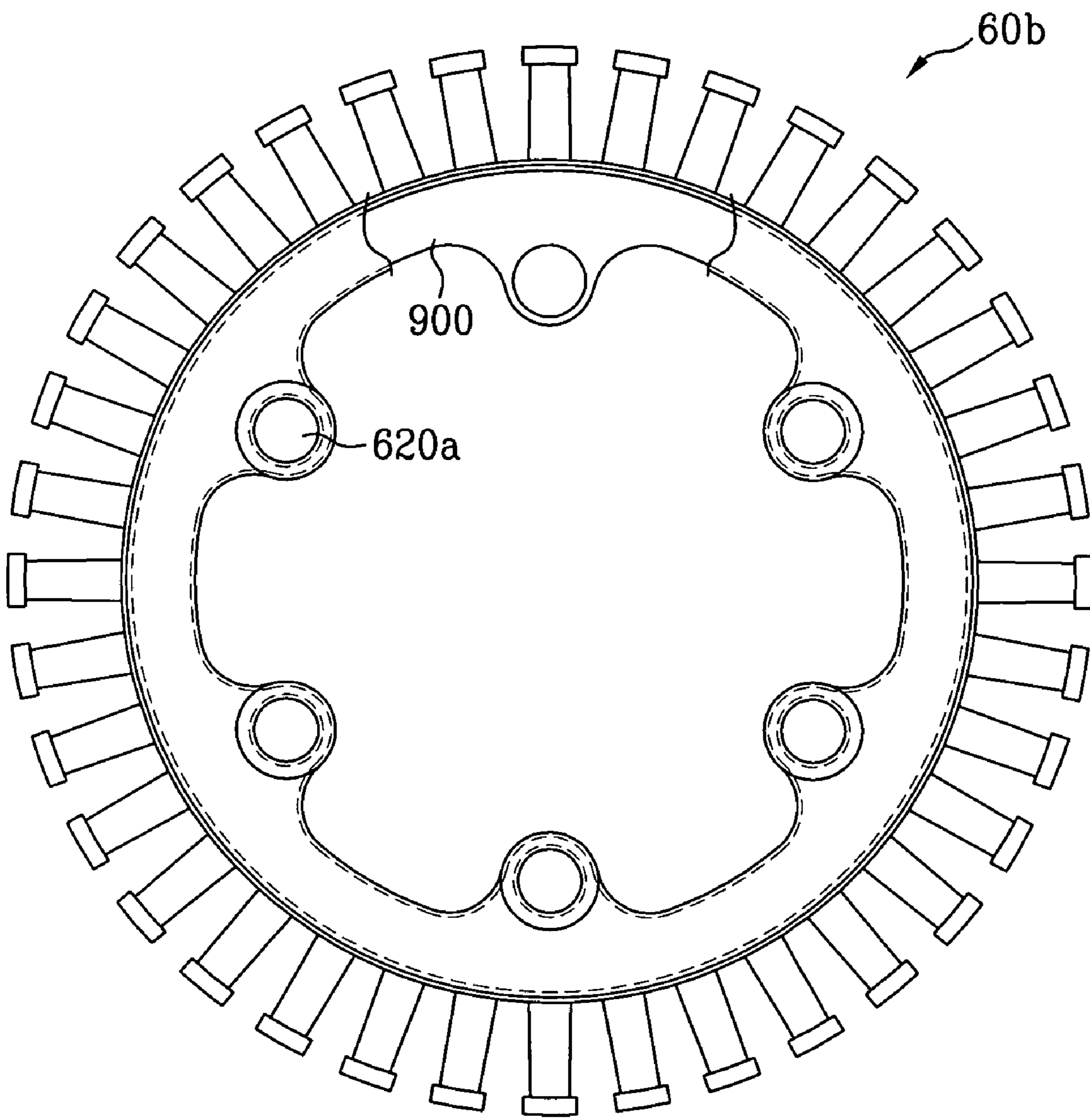

FIG. 24

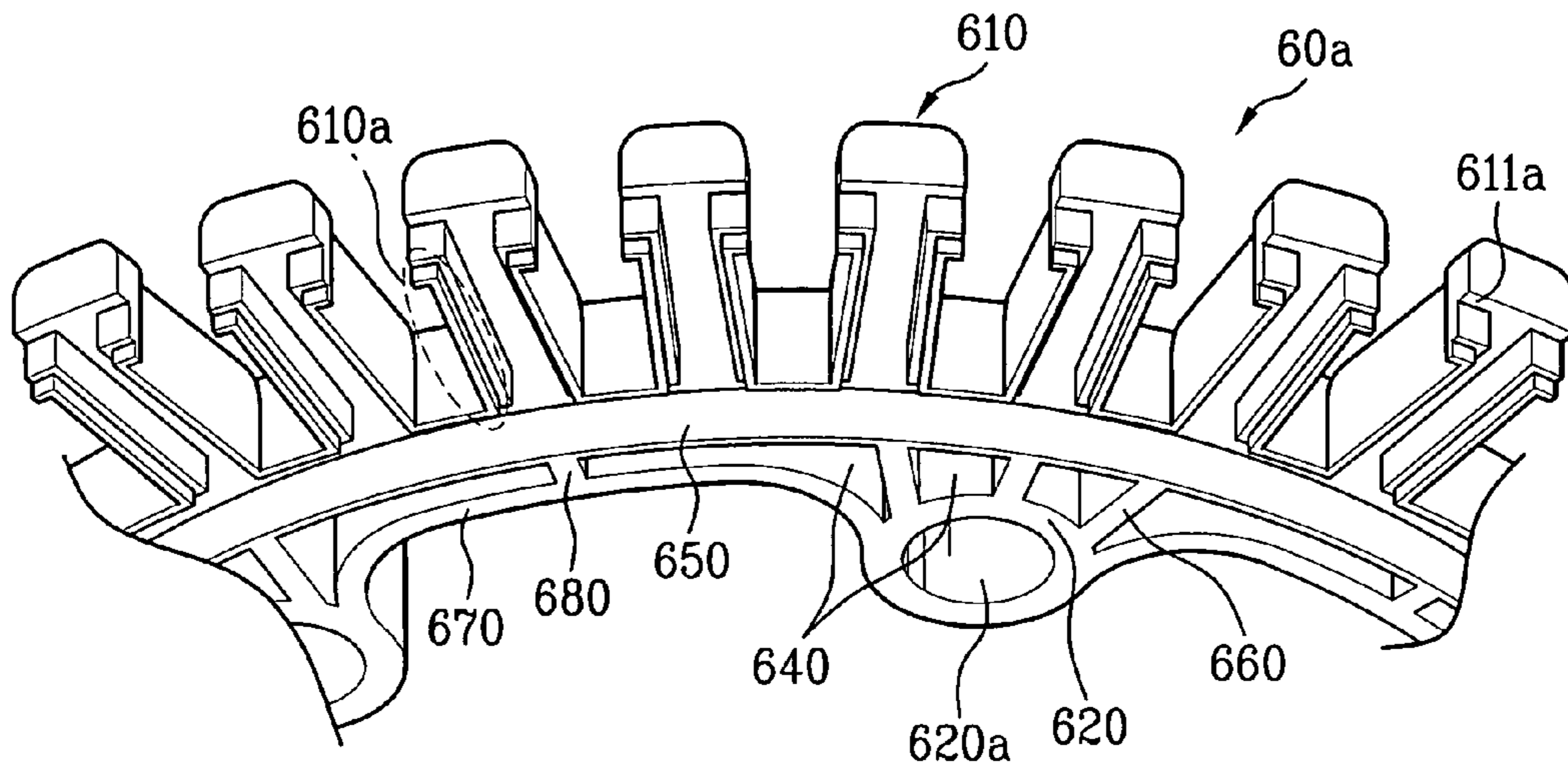

FIG. 25

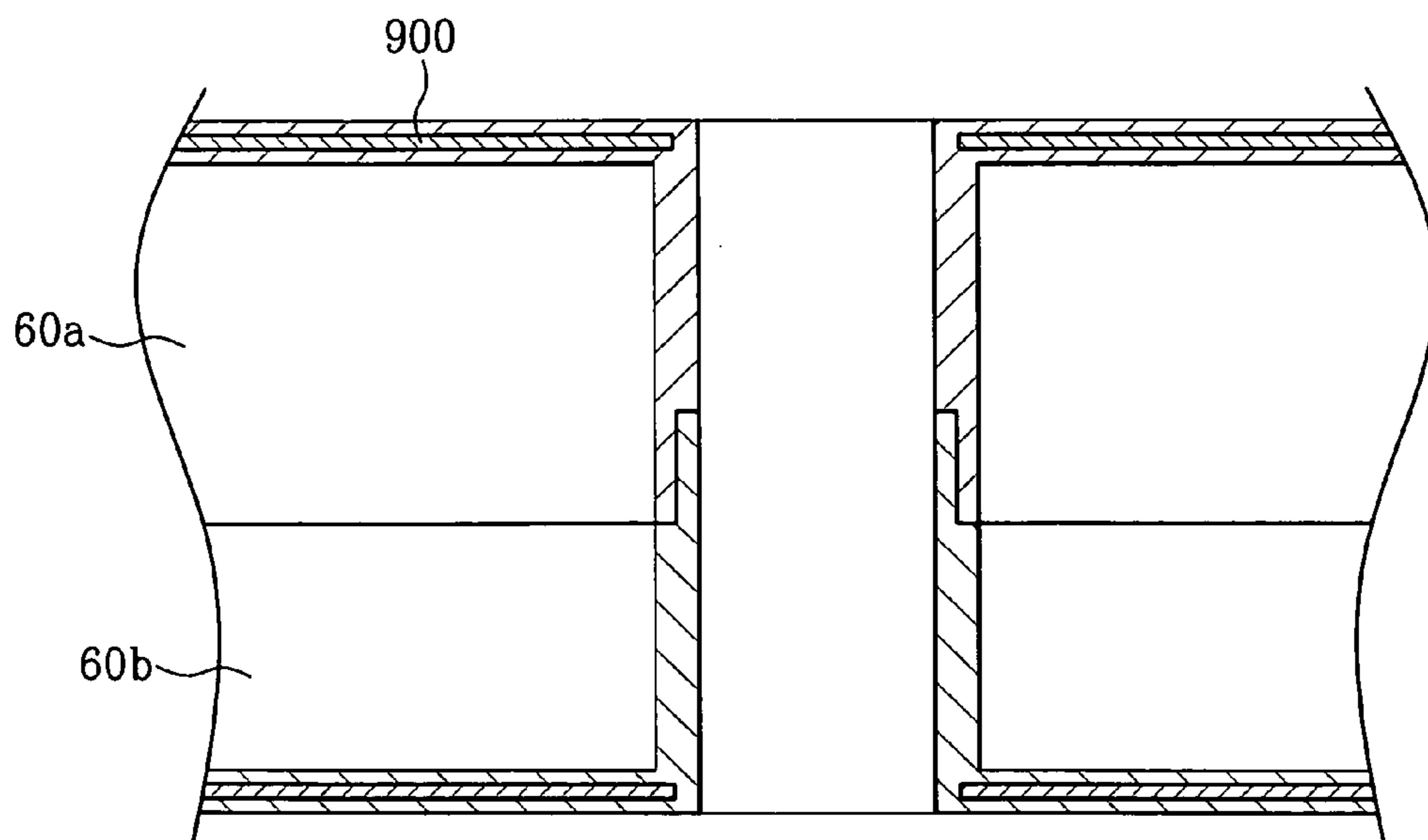

FIG. 26

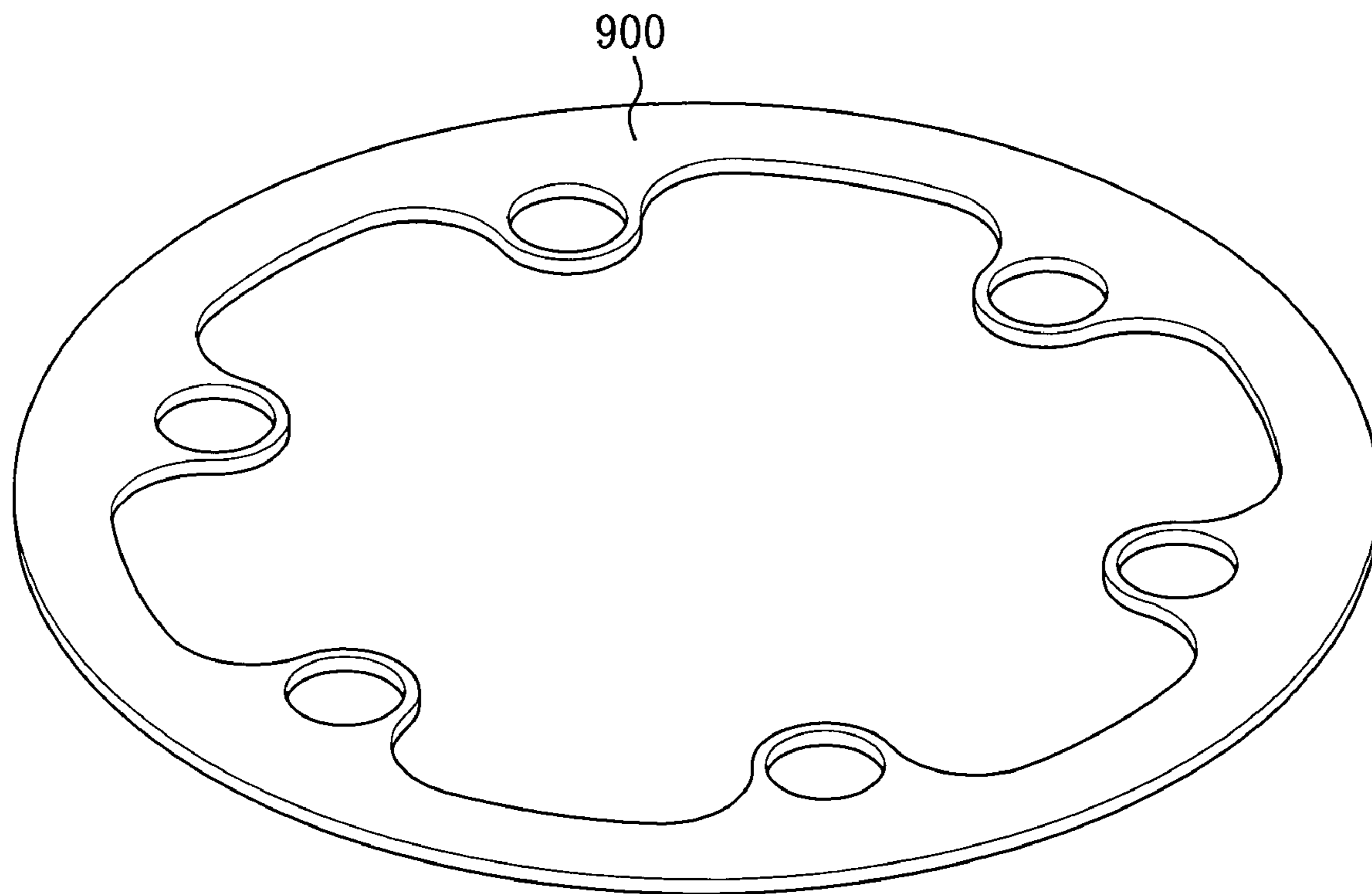

FIG. 27

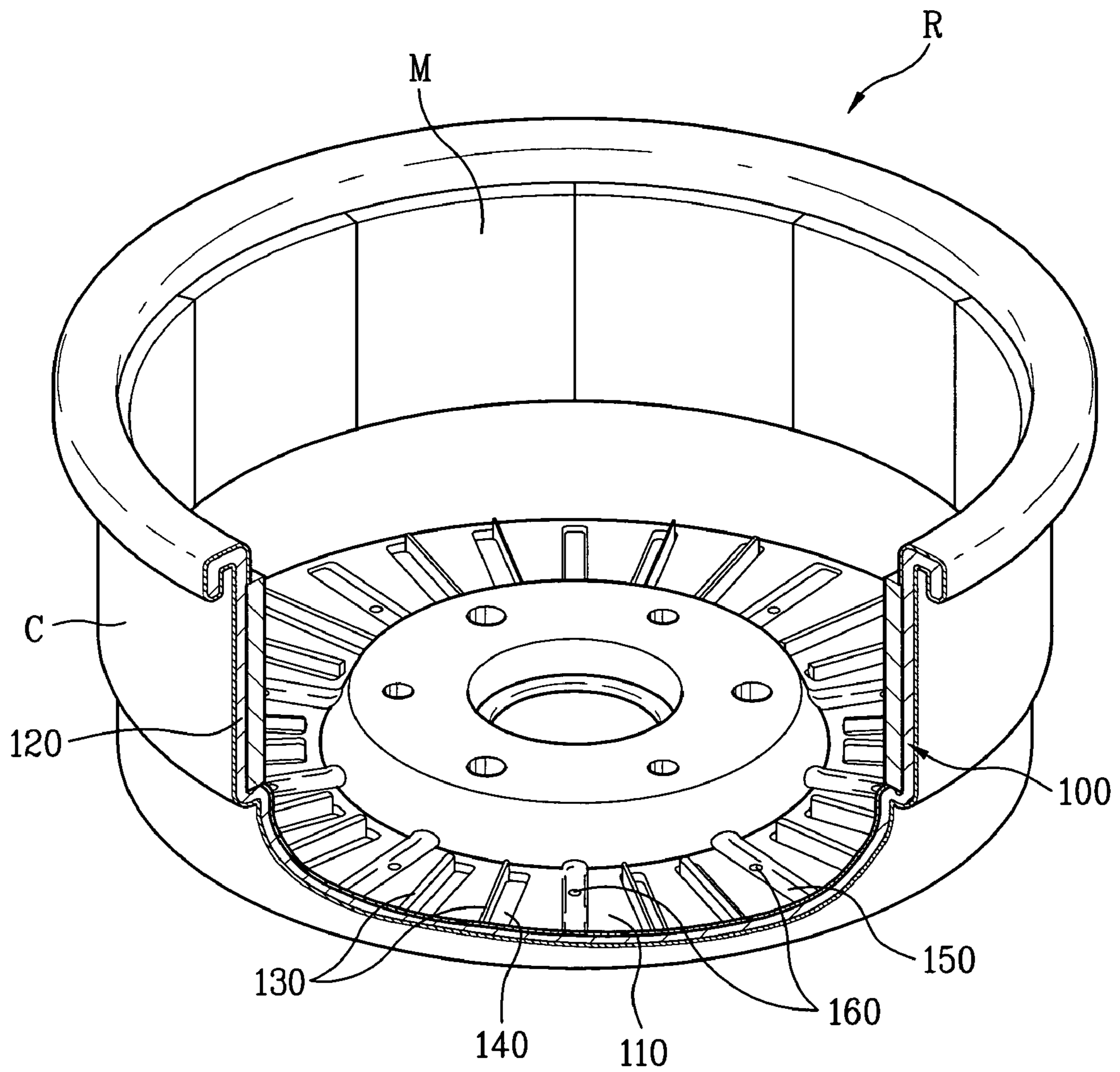

FIG. 28

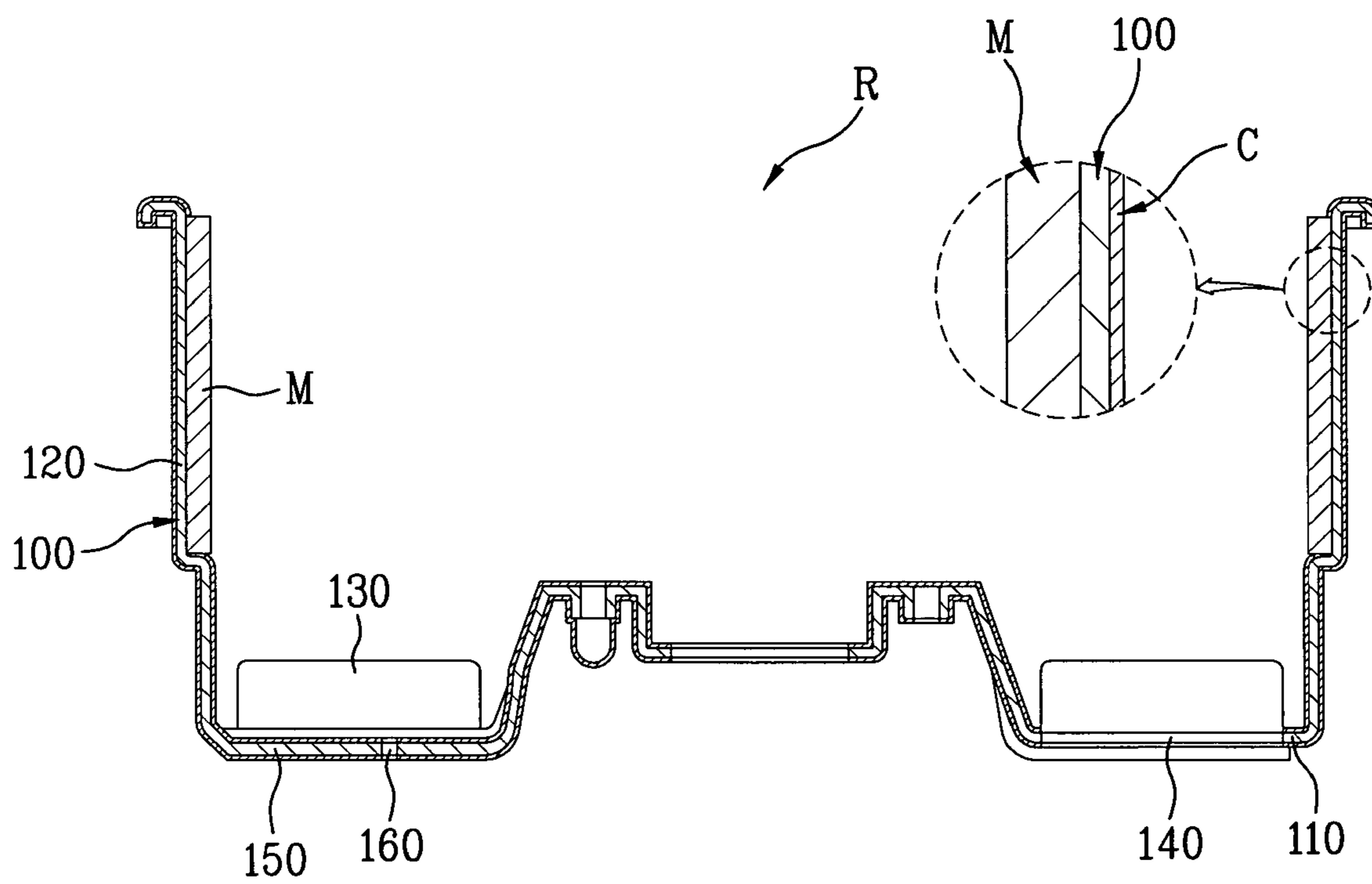

FIG. 29

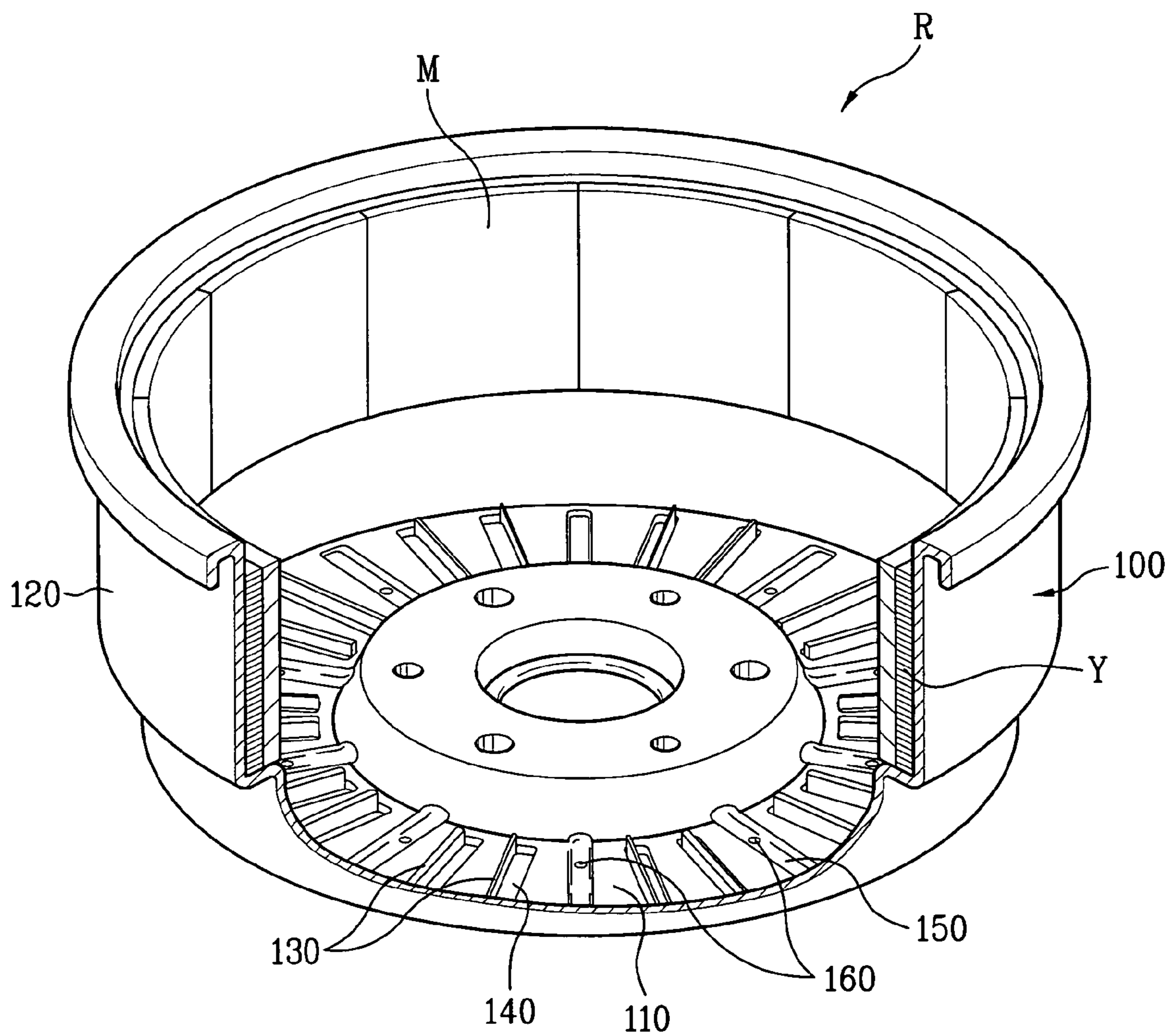
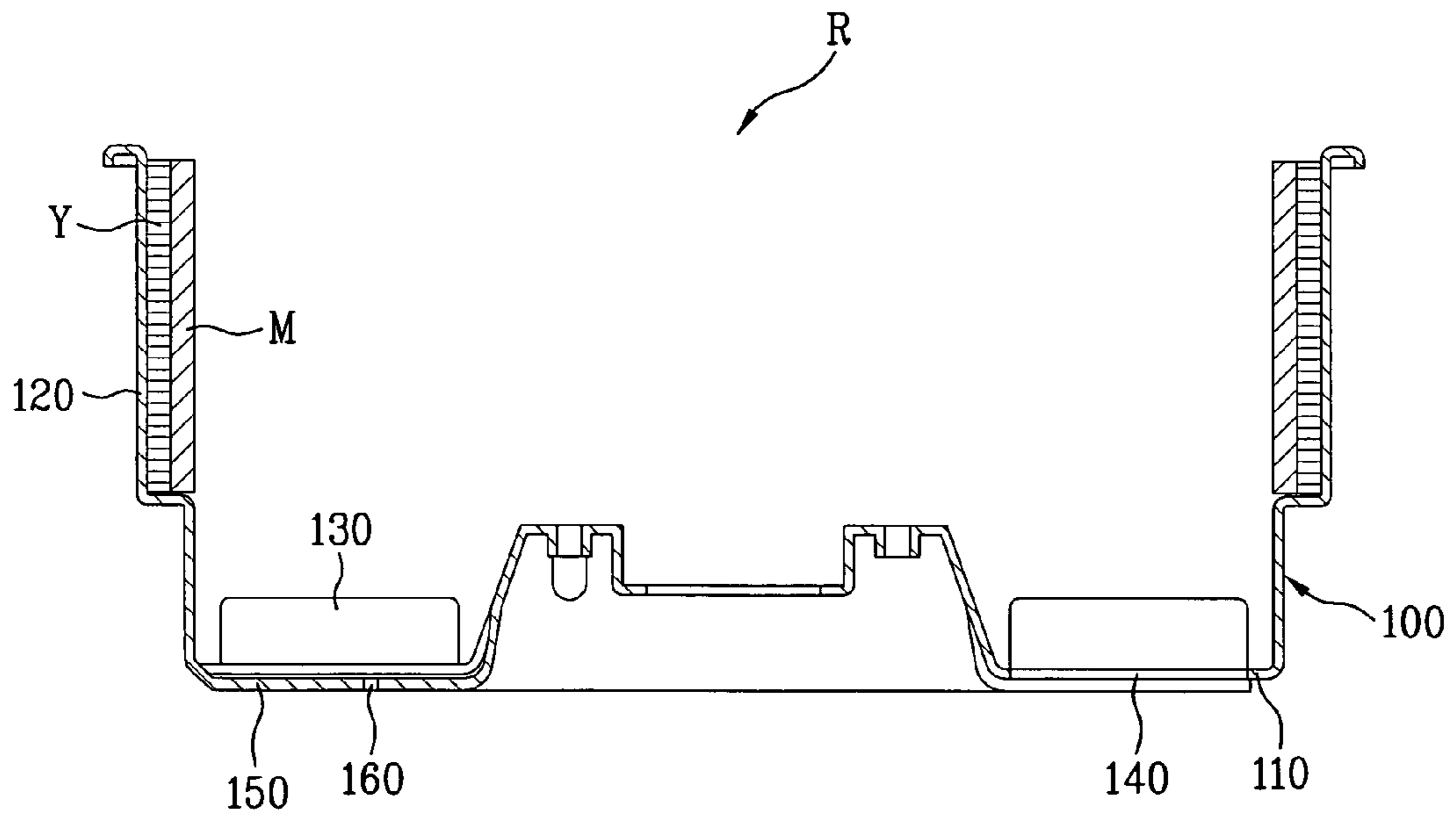

FIG. 30



1

OUTER ROTOR TYPE MOTOR FOR DRUM TYPE WASHING MACHINE AND METHOD FOR FABRICATING THE SAME

CROSS-REFERENCE TO RELATED APPLICATIONS

This application claims the benefit of Korean Application Nos. P2003-0089721, 0089722, 0089723, 0089724, and 0089726 all of which were filed on Dec. 10, 2003, and are hereby incorporated by reference as if fully set forth herein.

BACKGROUND OF THE INVENTION

1. Field of the Invention

The present invention relates to drum type washing machines, and more particularly, to an outer rotor type BLDC motor applicable to a direct coupling type drum type washing machine, and a method for fabricating the same.

2. Discussion of the Related Art

In general, a drum type washing machine washes laundry by using a friction force between a drum rotated by a driving power of a motor and laundry in a state detergent, washing water, and the laundry are introduced into the drum, shows almost no damage to, and entangling of the laundry, and has pounding, and rubbing washing effects.

In the related art drum type washing machines, there are an indirect coupling type in which the driving power is transmitted from the motor to the drum through a belt wound on a motor pulley and a drum pulley indirectly, and a direct coupling type in which a rotor of a BLDC motor is coupled to the drum directly, to transmit the driving power from the motor to the drum, directly.

The type in which the driving power of the motor is transmitted to the drum, not directly, but indirectly through the motor pulley and the drum pulley, has much energy loss in the course of power transmission, and causes much noise in the course of power transmission.

According to this, for solving the problems of the indirect coupling type drum type washing machines, it is the present trend that use of the direct coupling type drum type washing machines with the BLDC motor is increasing, as example of which there are Korean Laid Open Patent Nos. 2001-37517, and 2001-37518.

A related art direct coupling type drum type drum type washing machine and a structure of a motor thereof will be described with reference to FIGS. 1 to 6, briefly. FIG. 1 illustrates a longitudinal section of a related art drum type washing machine.

Referring to FIG. 1, the related art drum type washing machine is provided with a tub 2 mounted on an inside of a cabinet 1, and a drum 3 rotatably mounted on a central portion of an inside of the tub 2. There is a motor in rear of the tub 2, wherein a stator 6 is secured to a rear wall of the tub, and a rotor 5 surrounds the stator 6, and is connected to the drum 3 with a shaft passed through the tub.

In the meantime, there are a door 21 mounted on a front of the cabinet 1, and a gasket 22 between the door 21 and the tub 2.

There are hanging springs 23 between an inside surface of an upper portion of the cabinet 1, and an upper portion of an outside circumferential surface of the tub 2, and a friction damper 24 between the inside surface of a lower portion of the cabinet 1, and a lower portion of the outside circumferential surface of the tub 2.

2

FIG. 2 illustrates a perspective exterior view of the stator in FIG. 1, and FIG. 3 illustrates a perspective view of a divisional type core DC applied to the stator in FIG. 2.

In a related art method for fabricating the core, a sheet of metal plate is pressed to form a unit core having Ts 151, a base portion 150, and projected portions 500 opposite to the Ts 151 each for forming fastening hole 500a therein, the unit cores are stacked to form a unit core assembly, and the unit core assemblies are connected to each other in a circumferential direction, to complete fabrication of the stator core, called the divisional core DC.

The projected portion 500 provides the fastening hole 620a for fastening the stator 6 to the rear wall of the tub, and serves to endure a fastening force of a bolt.

However, the method for fabricating the stator 6 by means of the divisional cores DC has, not only a complicate fabrication process, but also loss of much material.

Therefore, even if a helical type core HC is favorable, in which a sheet of steel plate having the Ts 151 and the base portions 150 is stacked turning in a helix for reducing the material loss, and making the fabrication process simple, since it is required to bend the sheet of metal punched out in a shape of a stripe into the helix, the helical core has a drawback in that the projected portion for fastening the stator to the tub can not be formed on an inner side of the core.

This is because, if the projected portion 500 is formed on the inner side of the core in fabrication of the helical core HC, a large width of the core at a portion having the projected portion formed thereon impedes bending of the core.

Therefore, currently, for employing the helical type core HC, a stator structure is required, in which a function the same with the projected portion of the divisional core DC is made to be carried out, not by the core itself, but by other portion.

For reference, a reason why it is important to secure an adequate rigidity of the projected portion having the fastening hole formed in for fastening the stator to the tub is as follows.

The washing machine in which the drum is directly rotated by the BLDC motor has the stator mounted on a rear portion of the tub, directly. In a case of the motor for a large capacity drum type washing machine with more than 1.5 kg of stator net weight, and a spinning speed in a range of 600~2000 RPM, it is liable that a fastened portion of the stator 6 is broken due to the stator weight, and vibration, shaking, and deformation of the rotor 5 in the high speed rotation.

Particularly, in a case of the drum type washing machine, in which the BLDC motor is used, and the stator 6 is secured to the tub rear wall, where an axis direction of the stator 6 is substantially parallel to ground, the vibration generated during operation of the washing machine causes intensive damage to the fastening portion of the stator 6 to the tub

Thus, an adequate rigidity of the projected portion having the fastening hole formed wherein is very important in fastening the stator 6 to the tub.

A related art outer rotor will be described with reference to FIGS. 5 and 6.

Referring to FIGS. 5 and 6, because the outer rotor R pressed of a steel plate (hereafter called as "steel plate rotor") has a stepped portion along a circumferential direction formed a sidewall 120 extended from a circumference of a bottom 110 of the rotor frame 100 perpendicular to a bottom 100 surface, to support magnets M when the magnets

M are attached to an inside surface of the sidewall **120** of the rotor frame **100**, fabrication of the outer rotor is easy.

Moreover, there are a plurality of radial cooling fins **130** around a center portion of the bottom **110** of the rotor frame **100** of the steel plate rotor R to blow air toward the stator (not shown) to cool down heat generated at the stator.

The cooling fins **130** are lanced toward an opened side of the rotor, and openings formed by the lancing serve as vent holes.

There are embossed portions **150** between adjacent cooling fins **130** on the bottom **110** of the rotor frame **100** for reinforcing strength of the rotor, and there are drain holes **160** in the embossed portions **150** for draining water.

However, the related art steel plate rotor R has the following problems.

Despite of anti-rusting heat treatment of a surface of the related art steel plate rotor R, rust occurs on a portion of the surface scratched during transportation or other situations.

The surface of the rotor also corrodes due to chemical reaction of detergent stuck to the surface of the rotor as the drum type washing machine is used for a long time.

In the meantime, during the spinning for water extraction, the sidewall **120** of the related art steel plate rotor **100** throbs intensely due to electromagnetic interaction (attraction and repulsion) with the stator, leading to increase noise.

SUMMARY OF THE INVENTION

Accordingly, the present invention is directed to an outer rotor type BLDC motor for a drum type washing machine, and a method for fabricating the same that substantially obviates one or more problems due to limitations and disadvantages of the related art.

An object of the present invention is to provide an outer rotor type BLDC motor for a drum type washing machine, which has a stator that can reduce material and weight required for fabrication, has a simple fabrication process, and can be mounted on a fixed side, such as a tub or a bearing housing securely.

Another object of the present invention is to provide a new stator structure which can be mounted on a fixed side, such as a tub or a bearing housing securely while reducing material for fabrication as described before so as to be suitable for a BLDC motor of a drum type washing machine, which has a weight over 1.5 kg only of the stator, and a rotation speed varying 0~2,000 RPM or over.

Another object of the present invention is to provide an outer rotor type BLDC motor for a drum type washing machine, which can prevent scratch on a surface of the steel plate outer rotor from occurring effectively, and cut off reaction of the surface with detergent effectively, for extending a lifetime of the motor, and improving reliability.

A further object of the present invention is to provide an outer rotor type BLDC motor for a drum type washing machine, which can enhance a rigidity of the outer rotor, solve the problem of throbbing and consequential noise.

Additional advantages, objects, and features of the invention will be set forth in part in the description which follows and in part will become apparent to those having ordinary skill in the art upon examination of the following or may be learned from practice of the invention. The objectives and other advantages of the invention may be realized and attained by the structure particularly pointed out in the written description and claims hereof as well as the appended drawings.

To achieve these objects and other advantages and in accordance with the purpose of the invention, as embodied

and broadly described herein, an outer rotor type motor for a drum type washing machine includes an annular stator core having multiple layers formed by winding a base portion in a shape of stripe with Ts projected from the base portion in a helix starting from a bottom layer to a top layer, an insulator insert molded to cover an outside surface of the stator core for insulating the stator core electrically, and fastening portions formed as one body with the insulator each projected from an inside circumferential surface of the stator core toward a center of the stator, for fixedly securing the stator to the tub, wherein the base portion of the stator core has an arc shaped slots each for reducing stress in winding the core as well as serving as a portion of a fastening hole, and each of the fastening portion of the insulator formed to cover the slots has a fastening hole formed therein.

In another aspect of the present invention, an outer rotor type motor for a drum type washing machine includes an annular stator core having multiple layers formed by winding a steel plate with a stripe shape of base portion and Ts projected from the base portion in a helix starting from a bottom layer to a top layer such that a layer overlaps with a next layer, an upper insulator of an electric insulating material covered on an upper side of the stator core in a shape complementary to a shape of the stator core, and a lower insulator of an electric insulating material covered on a lower side of the stator core at the time of assembly with the upper insulator in a shape complementary to a shape of the stator core, wherein each of the upper insulator and the lower insulator includes three or more than three fastening portions formed as one body therewith projected from an inside of the stator core toward a center of the stator for fastening the stator to a fixing side of the tub, and the fastening portion has a fastening hole for securing the stator to a tub wall with fastening members.

In another aspect of the present invention, an outer rotor type motor for a drum type washing machine includes an annular stator core having multiple layers formed by winding a steel plate with a stripe shape of base portion and Ts projected from the base portion in a helix starting from a bottom layer to a top layer such that a layer overlaps with a next layer, an upper insulator of an electric insulating material covered on an upper side of the stator core in a shape complementary to a shape of the stator core, and a lower insulator of an electric insulating material covered on a lower side of the stator core at the time of assembly with the upper insulator in a shape complementary to a shape of the stator core, wherein each of the upper insulator and the lower insulator includes three or more than three fastening portions formed as one body therewith projected from an inside of the stator core toward a center of the stator for fastening the stator to a fixing side of the tub, the fastening portion has a boss of a fastening hole for securing the stator to a tub wall, and there is a cylindrical metal placed around the boss.

In another aspect of the present invention, an outer rotor type motor for a drum type washing machine includes an annular stator core having multiple layers formed by winding a steel plate with a stripe shape of base portion and Ts projected from the base portion in a helix starting from a bottom layer to a top layer such that a layer overlaps with a next layer, an upper insulator of an electric insulating material covered on an upper side of the stator core in a shape complementary to a shape of the stator core, and a lower insulator of an electric insulating material covered on a lower side of the stator core at the time of assembly with the upper insulator in a shape complementary to a shape of

5

the stator core, annular supporters respectively inserted in the upper insulator and the lower insulator; wherein each of the upper insulator and the lower insulator, and the supporters inserted therein includes fastening portions projected from an inside of the stator core toward a center of the stator for fastening the stator to a fixing side of the tub, and the fastening portion has a fastening hole for securing the stator to a tub wall with fastening members.

In further aspect of the present invention, an outer rotor type motor for a drum type washing machine includes a stator core stacked by winding in a helix, an insulator of an insulating material having an upper side piece, and a lower side piece to cover the core when the upper side piece, and the lower side piece are joined together, an annular supporter of metal inserted in at least one of the upper insulator and the lower insulator, and fastening portions formed as one body with the upper, and lower insulators, and/or the supporter inserted therein, each of the fastening portions being projected from an inside of the stator core toward a center thereof for securing the stator to a fixing side of the tub.

In still further aspect of the present invention, an outer rotor type motor for a drum type washing machine includes an outer rotor of steel plate having a bottom, a sidewall extended from the bottom in perpendicular thereto substantially, and magnets on an inside of the sidewall, wherein the rotor frame and a back yoke are formed as one unit so that the rotor frame also serves as the back yoke, and the rotor frame has one coat of synthetic resin applied to at least an outside surface of the rotor frame.

In the meantime, in still further aspect of the present invention, an outer rotor type motor for a drum type washing machine includes an outer rotor of steel plate having a bottom, a sidewall extended from the bottom in perpendicular thereto substantially, and magnets on an inside of the sidewall, wherein an annular back yoke is mounted on an inside surface of the sidewall of the outer rotor, and the magnets are attached to an inside surface of the back yoke.

In still yet further aspect of the present invention, a method for fabricating an outer rotor type motor for a drum type washing machine includes the steps of forming an annular stator core having multiple layers formed by winding a steel plate with a stripe shape of base portion and Ts projected from the base portion in a helix starting from a bottom layer to a top layer such that a layer overlaps with a next layer, insert molding the stator core such that an insulating material covers the stator core, and an inside of a slot forms a portion of a fastening hole, and winding coils on Ts of the stator coil.

It is to be understood that both the foregoing general description and the following detailed description of the present invention are exemplary and explanatory and are intended to provide further explanation of the invention as claimed.

BRIEF DESCRIPTION OF THE DRAWINGS

The accompanying drawings, which are included to provide a further understanding of the invention and are incorporated in and constitute a part of this application, illustrate embodiment(s) of the invention and together with the description serve to explain the principle of the invention. In the drawings;

FIG. 1 illustrates a longitudinal section of a related art direct coupling type drum type washing machine, schematically;

FIG. 2 illustrates a perspective view of an exterior of the stator in FIG. 1;

6

FIG. 3 illustrates a perspective view of the divisional core in FIG. 2;

FIG. 4 illustrates a reference drawing showing a fabrication process of the divisional core in FIG. 3;

FIG. 5 illustrates a perspective view of the outer rotor in FIG. 1, with a partial cut away view;

FIG. 6 illustrates a section of FIG. 5;

FIG. 7 illustrates a perspective view of an exterior of the stator in accordance with a first preferred embodiment of the present invention;

FIG. 8 illustrates a perspective view of the core in the stator in FIG. 7;

FIG. 9 illustrates a plan view of key portions of FIG. 7;

FIG. 10 illustrates a cross sectional view of FIG. 9, showing an inside of a fastening portion for reference;

FIGS. 11 and 12 illustrate cross sectional views equivalent to FIG. 10, showing key portions of slots in accordance with another preferred embodiments of the present invention;

FIG. 13 illustrates an exterior perspective view of a stator in accordance with a second preferred embodiment of the present invention;

FIG. 14 illustrates a disassembled perspective view of FIG. 13;

FIG. 15 illustrates a bottom perspective view of a portion of the upper insulator in FIG. 14;

FIG. 16 illustrates a section showing a fastening portion across a line I-I in FIG. 13;

FIGS. 17 and 18 are reference drawings, illustrating a versatility of application of the insulators;

FIG. 19 illustrates a section of a fastening portion corresponding to FIG. 16 in accordance with another preferred embodiment;

FIG. 20 illustrates a perspective view of an exterior of a stator in accordance with a third preferred embodiment of the present invention;

FIG. 21 illustrates a disassembled perspective view of FIG. 20;

FIG. 22 illustrates a plan view of an upper insulator;

FIG. 23 illustrates a plan view of a lower insulator;

FIG. 24 illustrates a perspective view of a bottom of a portion of the upper insulator in FIG. 21;

FIG. 25 illustrates a section of a fastening portion across a line II-II in FIG. 21;

FIG. 26 illustrates a perspective view of a supporter of a metal ring shape applicable to the stator in FIG. 20;

FIG. 27 illustrates a perspective view of an outer rotor in accordance with a fourth preferred embodiment of the present invention, with a partial cut away view;

FIG. 28 illustrates a section of FIG. 27;

FIG. 29 illustrates a perspective view of an outer rotor in accordance with a fifth preferred embodiment of the present invention, with a partial cut away view; and

FIG. 30 illustrates a section of FIG. 29.

DETAILED DESCRIPTION OF THE INVENTION

Reference will now be made in detail to the preferred embodiments of the present invention, examples of which are illustrated in the accompanying drawings FIGS. 7 to 34. Wherever possible, the same reference numbers will be used throughout the drawings to refer the same or like parts.

A first embodiment of the present invention will be described.

FIG. 7 illustrates a perspective view of an exterior of the stator in accordance with a first preferred embodiment of the

present invention, FIG. 8 illustrates a perspective view of the core in the stator in FIG. 7, FIG. 9 illustrates a plan view of key portions of FIG. 7, and FIG. 10 illustrates a cross sectional view of FIG. 9, showing an inside of a fastening portion for reference.

The stator 6 of a direct coupling type motor in accordance with a first preferred embodiment of the present invention includes an annular stator core 15 having multiple layers formed by winding a steel plate with Ts 151 and base portion 150 in a helix starting from a bottom layer to a top layer such that a layer overlaps with the next layer, an insulator 144 insert molded to cover an outside surface of the stator core for insulating the stator core electrically, and three or more fastening portions 143 formed as one body with the insulator 144 each projected from an inside circumferential surface of the stator core 15 toward a center of the stator 6, for fixedly securing the stator 6 to the tub 2, wherein the base portion 150 of the stator core 15 has arc shaped slots 152 each for reducing stress in winding the core as well as serving as a portion of a fastening hole 143a, and each of the fastening portion 143 of the insulator 144 formed to cover the slots 152 has a fastening hole 143a formed therein.

A process for fabricating the stator in accordance with a preferred embodiment of the present invention will be described.

A Core having the stripe shaped base portion 150 with the arc shaped slots 152, and Ts 151 projected from the base portion 150 is punched from an electric sheet, a base metal. In this instance, of the core is straight.

Then, the punched core is wound in a helix from a bottom layer to a top layer such that a layer overlaps with the next layer, to form a multiple layered annular stator core 15.

In view of a geometric characteristic, the stator core 15 is also called as a helical core HC, and the multiple layers thereof are fastened with rivets 153 passed through pass through-holes in the base portion 150.

The arc shaped slots 152 reduce stress during winding the core, enabling to wind the core with a smaller force.

Then, an insert molding is performed to cover the stator core 15 with an insulating material, such as plastic, or the like.

The insulating material covers the stator core 15 such that an inside of the slot 152 forms a portion of the fastening hole 143a.

That is, in an inside direction of the slot 152, there is the fastening portion 143 of the insulator 144, and the fastening portion has a bolt fastening hole 143a.

After finishing the insert molding, a coil is wound around each of the Ts 151 of the core 15.

The foregoing stator core in accordance with a first preferred embodiment of the present invention works as follows.

Different from the divisional core, the application of so called helical core HC, formed by stacking a steel plate having Ts 151 and a base portion 150 while winding in a helix, to the embodiment as the stator core 15 permits the embodiment to omit steps of aligning, and welding the core segments, to simplify a fabrication process.

Moreover, different from the divisional core, since the stator core 15 has no projected portion, the stator core 15 permits to reduce waste of material.

That is, the method for fabricating a stator in accordance with the embodiment not only has a simple fabrication process, but also permits to reduce waste of material.

Furthermore, by improving structures of the stator core 15 and the insulator 144, the stator 6 has an adequate rigidity

against bolt fastening force even is the stator 6 has no projected portion on the core itself like the divisional core DC.

That is, the arc shaped slot 152 is formed in an inside surface of the helical type stator core, and the insulator 144 is formed on an exterior of the core by insert molding, wherein the insulator 144 on the exterior of the core forms a circular hole together with the arc shaped slot on the inside of the core.

That is, since the stator core 15 has a shape of a helical core HC with an inside of the slot 152 being a portion of the bolt fastening hole 143a, at the time of bolt fastening for securing the stator 6 to the tub 2, a portion of bolt head of the bolt presses down an upper surface of the insert molded core, and rest of the bolt head presses down an upper surface of the fastening portion 143 of the insulator 144.

According to this, the stator 6 can effectively prevent a fastening portion of the stator 6 suffering from breakage caused by vibration at the spinning, and shaking and deformation of the rotor 5 even at a large capacity drum type washing machine having a weight over 1.5 kg only of the stator, and a spinning speed ranging 600~2,000 RPM.

As a positioning projection 143b in the vicinity of the fastening hole 143a of the fastening portion 143 fits in a positioning hole (not shown) in the tub 2, fastening of the stator 6 is easy.

Thus, the positioning projection enables an easy assembly of the stator 6 with the tub 2, and a serviceman to make an easy repair at the time of after service.

Of course, the positioning projection may be formed on the tub 2, and the positioning hole may be formed in the fastening portion 143.

FIGS. 11 and 12 illustrate cross sectional views equivalent to FIG. 10, showing key portions of slots in accordance with another preferred embodiments of the present invention, wherein it can be noted that the slot 152 in the base portion 150 of the stator core 15 may be greater than a semicircle as shown in FIG. 11 or smaller than semicircle as shown in FIG. 12.

In other words, a center of a radius of the slot 152 may be positioned on an inside, or outside of the slot.

That is, more than one half of an area of the fastening hole 143a may be positioned on an inside of the slot as shown in FIG. 11, or on an outside of the slot as shown in FIG. 12.

In a case of FIG. 11, a contact area between the bolt head and the stator core 15 is large, to increase a supporting force against the bolt fastening force.

Moreover, the case permits an easy bending of the core at the time of winding the stator core in a helix.

A case of FIG. 12 is applicable to a general small sized motor because the contact area between the bolt head and the stator core 15 is small, to reduce the supporting force against the bolt fastening force.

Along with this, in the vicinity of the fastening hole 143a of the fastening portion, there is a positioning projection 143b in complementary to a positioning hole (not shown) in the tub 2.

A second preferred embodiment of the present invention will be described with reference to FIGS. 13~19.

FIG. 13 illustrates an exterior perspective view of a stator in accordance with a second preferred embodiment of the present invention, FIG. 14 illustrates a disassembled perspective view of FIG. 13, FIG. 15 illustrates a bottom perspective view of a portion of the upper insulator in FIG. 14, and FIG. 16 illustrates a section showing a fastening portion across a line I-I in FIG. 13.

The stator **6** of an outer rotor type motor in accordance with a second preferred embodiment of the present invention includes an annular stator core **15** having multiple layers formed by winding a steel plate with a stripe shape of base portion **150** and Ts **151** projected from the base portion **150** in a helix starting from a bottom layer to a top layer such that a layer overlaps with a next layer, an upper insulator **60a** of an electric insulating material covered on an upper side of the stator core **15** in a shape complementary to a shape of the stator core **15**, and a lower insulator **60b** of an electric insulating material covered on the lower side of the stator core **15** at the time of assembly with the upper insulator **60a** in a shape complementary to a shape of the stator core **15**, wherein each of the upper insulator **60a** and the lower insulator **60b** includes three or more than three fastening portions **600** formed as one body therewith projected from an inside of the stator core **15** toward a center of the stator **6** for fastening the stator **6** to a fixing side of the tub.

The fastening portion **600** (see FIG. **14**) has a fastening hole **620a** (see FIG. **15**) for securing the stator **6** to a fixing side, such as the tub, with a fastening member. The fastening hole **620a** is constructed of a boss **620** projected to a back side of the fastening portion **600**.

Each of the upper insulator **60a** and the lower insulator **60b** has a supporting rib **650** on an inside along a circumferential direction thereof in contact with the stator core **15** for supporting an inside surface of the core.

The fastening portion **600** of each of the upper insulator **60a** and the lower insulator **60b** has at least one reinforcing rib **660** connected between the boss **620** of the fastening hole **620a** and the supporting rib **650** for spreading fastening force concentrated on the boss **620** and reinforcing a strength of the fastening portion **600**.

In the meantime, the fastening portion **600** of each of the upper insulator **60a** and the lower insulator **60b** has a reinforcing rib **670** at an inside circumference thereof, and at least one connection rib **680** connected between the reinforcing rib **670** and the supporting rib **650** which supports an inside surface of the core in a radial direction, for providing a supporting force.

The reinforcing rib **670**, together with the reinforcing rib **660**, connects between the bosses **620** having fastening holes of the upper, and lower insulators, to spread the fastening force concentrated on the boss, and reinforce a strength of the fastening portion **600**.

In the meantime, each of the upper insulator **60a** and the lower insulator **60b** has tips **610a** and **610b** on opposite sidewalls of each of the Ts **610** thereof having shapes in complementary to each other for fitting in at the time of assembly to form a flush surface.

Each of the tips **610a** and **610b** on each of the Ts **610** has a "└" shape if the other side has a "┌" shape.

At the opposite end surfaces substantially perpendicular to the opposite sidewall surfaces of the teeth **610** of the upper insulator **60a** and the lower insulator **60b**, there are also the tips **610a** and **610b** having shape in complementary to each other.

The teeth **610** of each of the upper insulator **60a** and the lower insulator **60b** has a seating surface **611a** at an end for seating a core shoe **151a** of the stator core **15**.

Along with this, in the vicinity of the fastening hole **620a** of the fastening portion **600** of the upper insulator **60a**, there is a positioning projection **630** having a shape in complementary to a positioning hole or a slot (not shown) in the fixing side of the tub.

There is a cylindrical metal **800** in the fastening hole **620a**, a spring pin having an elasticity owing to an incised portion, or a hollow pin enabling press fit in the fastening hole **620a**, serves as a bushing.

In the meantime, the fastening hole **620a** of each of the upper insulator **60a** and the lower insulator **60b** has a land around the fastening hole **620a** for preventing the bolt head from being brought into direct contact with the cylindrical metal **800** at the time of bolt fastening.

The base portion **150** of the stator core **15** has slots **152** for reducing stress at the time of winding in formation of the core to make the winding easy, and the multiple layers thereof are fastened with rivets **153** passed through pass through holes in the base portion **150**.

In FIG. **14**, an unexplained reference numeral **8** denotes a hole sensor assembly for controlling the motor, and **9** denotes a tap housing assembly for tapping power to supply the power to a stator side.

The work of the second embodiment stator will be described.

Different from the divisional core DC, the application of so called helical core HC, formed by stacking a steel plate having Ts **151** and a base portion **150** while winding in a helix, to the embodiment as the stator core **15** also permits the embodiment to omit steps of aligning, and welding the core segments, to simplify a fabrication process.

Moreover, different from the divisional core, since the stator core **15** has no projected portion, the stator core **15** permits to reduce waste of material.

That is, a method for fabricating a stator of the embodiment not only simplifies a fabrication process, but also reduces waste of material.

Moreover, even if the stator **6** of the embodiment improves structures of the upper, and the lower insulator **60a**, and **60b** such that no projected portions are formed at the core itself for supporting the fastening force at the time of fastening the stator **6** to the tub side, the stator **6** still has a rigidity enough to support the bolt fastening force.

That is, by providing structures that work the same with the projected portion of the divisional core to the fastening portions **600** of the upper, and lower insulators **60a**, and **60b**, stator **6** can be provided, to which the helical core HC is applicable.

Moreover, spaces **640** between the ribs **650**, **660**, **670**, and **680** at a back side of the fastening portion **600** dampen and attenuate vibration occurred during driving the motor, to improve mechanical reliability of the stator **6**, and contribute to save material of the insulators.

The supporting ribs **650** of the upper insulator **60a** and the lower insulator **60b** formed at an inside in contact with the stator core **15** along the circumferential direction support an inside surface of the stator core **15**.

The reinforcing rib **660** connected between the boss **620** of the fastening hole **620a** and the supporting rib **650** at each of the fastening portion **600** of the upper insulator **60a** and the lower insulator **60b** spreads the fastening force concentrated on the boss **620**, and reinforces a strength of the fastening portion **600**.

According to this, the stator **6** can effectively prevent a fastening portion of the stator **6** suffering from breakage caused by vibration at the spinning, and shaking and deformation of the rotor **5** even at a large capacity drum type washing machine having a weight over 1.5 kg only of the stator, and a spinning speed ranging 600~2,000 RPM.

11

As a positioning projection **630**, or **143b** in the vicinity of the fastening hole **620a** of the fastening portion **600** fits in a positioning hole (not shown) in the tub **2**, fastening of the stator **6** is easy.

Thus, the positioning projection enables an easy assembly of the stator **6** with the tub **2**, and a serviceman to make an easy repair at the time of after service.

Of course, the positioning projection **630** may be formed on the tub **2**, and the positioning hole may be formed in the fastening portion **600**.

In the meantime, FIGS. **17** and **18** are reference drawings, illustrating a versatility of application of the insulators, wherein it can be noted that the upper, and lower insulators **60a** and **60b** are applicable even if a total height of the helical core varies within a certain range.

That is, FIG. **17** illustrates a case when a total height **h1** of the core is a height which permits tips **610a** and **610b** of the upper, and lower insulators **60a** and **60b** fit exactly, and FIG. **18** illustrates a case when a total height of the core is a height greater than a case of FIG. **17** such that the tips **610a** (see FIGS. **14** and **15**) and **610b** (see FIG. **15**) of the upper, and lower insulators **60a** and **60b** unable to fit exactly, but spaced a certain distance.

Even if the total height **h2** of the core is greater than a height that permits the tips **610a** and **610b** of the upper, and lower insulators **60a** and **60b** fit exactly, such that there is a space between the tips **610a** and the **610b**, because the insulation against the core **Ts** is still achievable, the upper, and lower insulators **60a** and **60b** are applicable to the case of FIG. **18**, too.

Thus, since the separate type upper, and lower insulators of the embodiment are applicable to the core regardless of the total height of the core within a certain range of the total height, the separate type upper, and lower insulators of the embodiment can improve workability on an assembly line.

FIG. **19** illustrates a section of a fastening portion corresponding to FIG. **16** in accordance with another preferred embodiment, wherein a cylindrical metal **800** is mounted on an outside of the boss **620** of the fastening hole **620a** in the fastening portion **600** of each of the upper, and lower insulators **60a**, and **60b**.

That is, in this embodiment, a boss **620** of the fastening hole **620a** which is formed to secure the stator **6** to a fixing side, such as the tub, is formed on a back side of the upper and lower insulators **60a**, and **60b**, and a cylindrical metal **800** is placed around the boss. This placement of the cylindrical metal on the outside of the boss is made possible owing to the separable upper, and lower insulators.

A third embodiment stator core will be described with reference to FIGS. **20**~**26**.

FIG. **20** illustrates a perspective view of an exterior of a stator in accordance with a third preferred embodiment of the present invention, FIG. **21** illustrates a disassembled perspective view of FIG. **20**, FIG. **22** illustrates a plan view of an upper insulator, and FIG. **23** illustrates a plan view of a lower insulator.

FIG. **24** illustrates a perspective view of a bottom of a portion of the upper insulator in FIG. **21**, FIG. **25** illustrates a section of a fastening portion across a line II-II in FIG. **21**, and FIG. **26** illustrates a perspective view of a supporter of a metal ring shape applicable to the stator in FIG. **20**.

Referring to FIGS. **20**~**26**, the stator **6** of an outer rotor type motor in accordance with a third preferred embodiment of the present invention includes an annular stator core **15** having multiple layers formed by winding a steel plate with a stripe shape of base portion **150** and **Ts** **151** projected from the base portion **150** in a helix starting from a bottom layer

12

to a top layer such that a layer overlaps with a next layer, an upper insulator **60a** of an electric insulating material covered on an upper side of the stator core **15** in a shape complementary to a shape of the stator core **15**, a lower insulator **60b** of an electric insulating material covered on the lower side of the stator core **15** at the time of assembly with the upper insulator **60a** in a shape complementary to a shape of the stator core **15**, and annular supporters **900** of metal inserted to the upper insulator and the lower insulator, respectively.

Each of the upper insulator, the lower insulator, and the supporters **900** inserted in the upper insulator and the lower insulator respectively has three or more than three fastening portions **600** projected from an inside of the stator core **15** toward the center of the stator **6** for securing the stator **6** to a fixing side of the tub.

The fastening portion **600** has a fastening hole **620a** for securing the stator **6** to a fixing side, such as the tub, with fastening members. The fastening hole **620a** is constructed of a boss **620** projected on a back side of the fastening portion **600**.

Each of the upper insulator **60a** and the lower insulator **60b** has a supporting rib **650** on an inside along a circumferential direction thereof in contact with the stator core **15** for supporting an inside surface of the core.

The fastening portion **600** of each of the upper insulator **60a** and the lower insulator **60b** or **60b** has at least one reinforcing rib **660** connected between the boss **620** of the fastening hole **620a** and the supporting rib **650** for spreading fastening force concentrated on the boss **620** and reinforcing a strength of the fastening portion **600**.

In the meantime, it is preferable that the fastening portion **600** of each of the upper insulator **60a** and the lower insulator **60b** has a reinforcing rib **670** at an inside circumference thereof in the back side, and at least one connection rib **680** connected between the reinforcing rib **670** and the supporting rib **650** which supports an inside surface of the core in a radial direction, for providing a supporting force.

In the meantime, each of the upper insulator **60a** and the lower insulator **60b** has tips **610a** and **610b** on opposite sidewalls of each of the **Ts** **610** thereof having shapes in complementary to each other for fitting in at the time of assembly.

Each of the tips **610a** and **610b** on each of the **Ts** **610** has a "L" shape if the other side has a "┐" shape.

At the opposite end surfaces substantially perpendicular to the opposite sidewall surfaces of the teeth **610** of the upper insulator **60a** and the lower insulator **60b**, there are also the tips **610a** and **610b** having shape in complementary to each other.

The teeth **610** of each of the upper insulator **60a** and the lower insulator **60b** has a seating surface **611a** at an end for seating a core shoe **151a** of the stator core **15**.

Along with this, in the vicinity of the fastening hole **620a** of the fastening portion **600** of the upper insulator **60a**, there is a positioning projection **630** having a shape in complementary to a positioning hole or a slot (not shown) in the fixing side of the tub.

The metal supporters **900** inserted in the upper insulator **60a** and the lower insulator **60b** serve as portions to support the fastening force when the fastening force is applied for securing the stator **6** to a tub wall.

In the meantime, the fastening hole **620a** of each of the upper insulator **60a** and the lower insulator **60b** has a land around the fastening hole **620a** for landing of the bolt head at the time of bolt fastening.

There may be a metal tube or a spring pin on an inside of the fastening hole **620**, for reinforcing strength of the fastening portion.

The base portion **150** of the stator core **15** has slots **152** for reducing stress at the time of winding in formation of the core to make the winding easy, and the multiple layers thereof are fastened with rivets **153** passed through pass through holes in the base portion **150**.

In FIG. **21**, unexplained reference numeral **8** denotes a hole sensor assembly for controlling the motor, and **9** denotes a tap housing assembly for tapping power to supply the power to a stator side.

The work of the third embodiment stator will be described.

Different from the divisional core DC, the application of so called helical core HC, formed by stacking a steel plate having Ts **151** and a base portion **150** while winding in a helix, to the embodiment as the stator core **15** permits the embodiment to omit steps of aligning, and welding the core segments, to simplify a fabrication process.

Moreover, different from the divisional core, since the stator core **15** has no projected portion, the stator core **15** can reduce waste of material.

That is, a method for fabricating a stator of the embodiment not only simplifies a fabrication process, but also reduces waste of material.

Moreover, even if the stator **6** of the embodiment improves structures of the upper, and the lower insulator **60a**, and **60b** such that no projected portions are formed at the core itself for supporting the fastening force at the time of fastening the stator **6** to the tub side, the stator **6** still has a rigidity enough to support the bolt fastening force.

That is, by providing structures that work the same with the projected portion of the divisional core to the fastening portions **600** of the upper, and lower insulators **60a**, and **60b**, and the fastening portions **600** of the supporter **900** inserted in the upper, and lower insulators **60a** and **60b**, a stator **6** can be provided, to which the helical core HC is applicable.

Especially, different from the second embodiment, because the supporters **900** are inserted in the upper, and lower insulators **60a**, and **60b** additionally, which are formed of metal, such as steel plate, the stator core of the third embodiment have adequate rigidity against the bolt fastening force.

Moreover, spaces **640** between the ribs **650**, **660**, **670**, and **680** at a back side of the fastening portion **600** dampen and attenuate vibration occurred during driving the motor, to improve mechanical reliability of the stator **6**, and contributes to save material of the insulators.

The supporting ribs **650** of the upper insulator **60a** and the lower insulator **60b** formed at an inside in contact with the stator core **15** along the circumferential direction support an inside surface of the stator core **15**.

The reinforcing rib **660** connected between the boss **620** of the fastening hole **620a** and the supporting rib **650** at each of the fastening portion **600** of the upper insulator **60a** and the lower insulator **60b** spreads the fastening force concentrated on the boss **620**, and reinforces a strength of the fastening portion **600**.

According to this, the stator **6** can effectively prevent a fastening portion of the stator **6** suffering from breakage caused by vibration at the spinning, and shaking and deformation of the rotor **5** even at a large capacity drum type washing machine having a weight over 1.5 kg only of the stator, and a spinning speed ranging 600~2,000 RPM.

As a positioning projection **630**, or **143b** in the vicinity of the fastening hole **620a** of the fastening portion **600** fits in a positioning hole (not shown) in the tub **2**, fastening of the stator **6** is easy.

Thus, the positioning projection enables an easy assembly of the stator **6** with the tub **2**, and a serviceman to make an easy repair at the time of after service.

Of course, the positioning projection **630** may be formed on the tub **2**, and the positioning hole may be formed in the fastening portion **600**.

In the meantime, alike the second embodiment (see FIGS. **17** and **18**), the insulators of the third embodiment are also versatile.

That is, since the separate type upper, and lower insulators of the embodiment are applicable to the core regardless of the total height of the core within a certain range of the total height, the separate type upper, and lower insulators of the embodiment can improve workability on an assembly line.

In the meantime, in a case a metal bushing **800** is press fit to an inside of the fastening hole like the second embodiment (see FIG. **14**), a supporting force against the bolt fastening force at the time of fastening the stator can be enhanced further.

A fourth embodiment of the present invention will be described with reference to FIGS. **27**, and **28**. FIG. **27** illustrates a perspective view of an outer rotor in accordance with a fourth preferred embodiment of the present invention, with a partial cut away view, and FIG. **28** illustrates a section of FIG. **27**.

Referring to FIGS. **27** and **28**, the outer rotor R in accordance with the fourth embodiment of the present invention includes a rotor frame **100** of a steel plate, to serve as a back yoke too. The rotor frame **100** has synthetic resin coated on an outside surface thereof.

The rotor frame **100** of a steel plate includes a bottom **110**, and a sidewall **120** substantially perpendicular to the bottom, wherein the sidewall **120** of the rotor frame **100** also serves as a back yoke, and inside, and outside surfaces of the rotor frame **100** inclusive of an outside surface of the sidewall **120** have a coat C of synthetic resin.

The synthetic resin is coated by injection molding or the like, to a thickness below 3 mm.

The work of the outer rotor of the embodiment is as follows.

Owing to the synthetic resin coated layer C on the surface of the rotor frame **100**, even if the outer rotor R is scratched on the surface of the rotor during transportation or other situation, the synthetic resin coated layer C is scratched, but the surface of the rotor frame **100** inside of the coated layer C is not scratched, to protect the surface of the rotor frame **100**.

Moreover, because the synthetic resin coated layer C on the surface of the outer rotor R serves as a protection film, to prevent water or detergent from infiltrating into the surface of the rotor frame **100**, rusting or corrosion of the surface of the rotor frame **100** can be prevented.

Despite of the anti-rusting heat treatment on a surface of the related art steel plate rotor R, though the related art steel plate rotor R has problems in that rust occurs on a portion of the surface scratched during transportation or other situations as water infiltrates during use of the product, or the rust occurs on the surface due to chemical reaction of the detergent during long time use of the product, the outer rotor R of the present invention can prevent such problems owing to the protection of the synthetic resin coated layer C on the surface of the rotor frame **100**.

15

Particularly, the drawings of the embodiment illustrate that the synthetic resin is coated on an entire surface of the rotor, it is preferable that at least the outside circumferential surface of the sidewall **120** of the rotor frame **100** which has a high probability of coming into contact with water or detergent, and is liable to be scratched is coated with synthetic resin without fail, even if an entire surface, such as an inside surface and the outside surface, is not coated with synthetic resin, taking weight increase of the rotor, and a cooling time period increase of the synthetic resin in the injection molding caused by the synthetic resin coating into account.

Particularly, because the rotor becomes heavier, and a cooling time period of the synthetic resin becomes longer if a thickness of the coated synthetic resin is thicker than 3 mm, which is not favorable for mass production, it is preferable that the thickness of the synthetic resin is below 3 mm.

In the meantime, the outer rotor R of the embodiment also has a step portion along a circumferential direction having a supporting surface for seating the magnets M on the sidewall **120** of the rotor frame **100**.

Moreover, there are a plurality of radial cooling fins **130** around a center portion of the bottom **110** of the rotor frame **100** of the outer rotor R to blow air toward the stator to cool down heat generated at the stator.

The pass through holes **140** formed in parallel to the cooling fins **130** serve as vent holes, the embossed portions **150** between adjacent cooling fins **130** on the bottom **110** of the rotor frame **100** reinforces the rotor frame **100**, and water is drained through the drain holes **160** in the embossed portions **150**.

A fifth embodiment of the present invention will be described in detail, with reference to FIGS. **29** and **30**.

FIG. **29** illustrates a perspective view of an outer rotor in accordance with a fifth preferred embodiment of the present invention, with a partial cut away view, and FIG. **30** illustrates a section of FIG. **29**.

Referring to FIGS. **29** and **30**, the outer rotor R includes a rotor frame having a bottom **110**, and a sidewall **120** extended in a substantially vertical direction from a circumference of the bottom **110**, wherein an annular back yoke Y is mounted on an inside surface of the sidewall **120** of the rotor frame **100**, and magnets M are in turn attached to an inside surface of the back yoke Y

In this instance, it is preferable that a step portion is provided on the sidewall **120** of the rotor frame of the outer rotor R for forming a supporting surface the magnets M are to be seated thereon.

The annular yoke may be formed as one body without discontinued portion, or one body with discontinued portions.

The annular yoke formed as one body with discontinued portions may abut at the discontinued portions, or the discontinued portions may be welded, to connect the discontinued portions.

In the meantime, the annular back yoke Y may be a stack of thin plates, or one body without the stacking.

The back yoke Y may be secured to an inside surface of the sidewall **120** of the rotor frame of the outer rotor R, or the like.

Moreover, alike the fourth embodiment, it is preferable that the outer rotor of the embodiment also has a plurality of cooling fins **130** around a center of the bottom **110** of the rotor frame **100**, lanced toward an open side of the rotor frame **100**.

16

The pass through holes **140** formed parallel to the cooling fins **130** by lancing serve as vent holes.

There are embossed portions **150** between adjacent cooling fins **130** on the bottom **110** of the rotor frame **100** for reinforcing strength of the rotor, and there are drain holes **160** in the embossed portions **150** for draining water.

The work of the embodiment (i.e., the fifth embodiment) is as follows.

As the outer rotor R of the embodiment has the annular back yoke Y mounted on the inside surface of the sidewall **120** of the rotor frame **100**, and the magnets M attached to the inside surface of the back yoke Y again, rigidity of the outer rotor R is enhanced owing to the back yoke Y

That is, in a structure in which the back yoke Y is mounted at a position far from the center of the outer rotor R, and the magnets M are mounted at a position near to the center of the outer rotor R, which increases rigidity of the sidewall of the outer rotor R significantly owing to the back yoke Y which is in close contact with the rotor frame sidewall **120** of the outer rotor R, the throbbing of the rotor during spinning can be prevented, effectively.

Moreover, as the supporting surface at the sidewall **120** of the rotor frame **100** supports the back yoke Y and the magnets M at the same time, mounting of the back yoke is easy.

In the meantime, there are a plurality of radial cooling fins **130** around a center portion of the bottom **110** of the rotor frame **100** to blow air toward the stator to cool down heat generated at the stator.

Moreover, the pass through holes **140** formed in parallel to the cooling fins **130** serve as vent holes, and embossed portions **150** between adjacent cooling fins **130** on the bottom **110** of the rotor frame **100** reinforce strength of the rotor, and drain holes **160** in the embossed portions **150** drain water.

Though the present invention has been described taking the drum type washing machine as an example, the present invention is applicable to a pulsator type washing machine, too.

The present invention has the following advantages.

The present invention can reduce material and weight required for fabrication of the stator of the BLDC motor for a drum type washing machine, simplifies the fabrication process, and enables secure mounting of the stator on a fixing side, such as the tub.

Especially, because the present invention enables to reduce materials of the stator core and the insulator, and secure mounting of the stator on a fixing side, such as the tub or the bearing housing like the divisional core, the present invention is more suitable to a BLDC motor for a drum type washing machine that has a weight of 1.5 kg only of the stator, and a rotation speed varied 0~2,000 RPM or over.

The drum type washing machine of the present invention permits easy assembly of the stator and the tub on an assembly line, as well as easy repair during services.

Moreover, the employment of the helical core HC of which winding is easy permits to prevent waste of base metal, permits easy fabrication, and improves mechanical reliability and extends a lifetime owing to the enhanced rigidity of the fastening portion of the stator that reduces noise and vibration.

The coating of synthetic resin on a surface of the outer rotor of steel plate can prevent scratching of the surface of the outer rotor which is liable to occur during transportation.

Along with this, the effective cut off of chemical reaction with detergent even in a long time use extends a lifetime of the motor and improves reliability.

The back yoke Y in close contact with an inside surface of the sidewall 120 of the rotor frame 100 permits to increase rigidity of the sidewall of the outer rotor R significantly, to prevent the rotor from throbbing occurred at the time of spinning.

It will be apparent to those skilled in the art that various modifications and variations can be made in the present invention without departing from the spirit or scope of the inventions. Thus, it is intended that the present invention covers the modifications and variations of this invention provided they come within the scope of the appended claims and their equivalents.

What is claimed is:

1. An outer rotor type motor for a drum type washing machine comprising:

an annular stator core having multiple layers formed by winding a base portion in a shape of a stripe with Ts projected from the base portion in a helix starting from a bottom layer to a top layer;

an insulator, insert molded to cover an outside surface of the stator core for insulating the stator core electrically; and

fastening portions formed as one body with the insulator, each fastening portion having a fastening hole for fixedly securing the stator to a tub of the washing machine and projected from an inside circumferential surface of the insulator toward a center of the stator, wherein the fastening portions are formed to continuously extend from an upper end of the stator core to a lower end of the stator core.

2. The outer rotor type motor as claimed in claim 1, wherein the base portion of the stator core comprises arc shaped slots, each for reducing stress in winding the core as well as serving as a portion of a fastening hole.

3. The outer rotor type motor as claimed in claim 2, wherein the arc shaped slot is smaller or greater than a semicircle.

4. The outer rotor type motor as claimed in claim 1, wherein the fastening portion of the insulator includes a positioning projection in the vicinity of the fastening hole thereof having a shape in complementary to a positioning hole in a fixing side, such as a tub.

5. An outer rotor type motor for a drum type washing machine comprising:

an annular stator core having multiple layers formed by winding a steel plate with a stripe shape of base portion and Ts projected from the base portion in a helix starting from a bottom layer to a top layer such that a layer overlaps with a next layer;

an upper insulator of an electric insulating material covered on an upper side of the stator core in a shape complementary to a shape of the stator core; and

a lower insulator of an electric insulating material covered on a lower side of the stator core at the time of assembly with the upper insulator in a shape complementary to a shape of the stator core,

wherein each of the upper insulator and the lower insulator includes three or more than three fastening portions formed as one body therewith projected from an inside of the upper and lower insulator toward a center of the stator for fastening the stator to a fixing side of the tub, and each of the fastening portions has a fastening hole for securing the stator to a tub wall with fastening members, and each of the fastening portions extends to contact an adjacent fastening portion.

6. The outer rotor type motor as claimed in claim 5, wherein the fastening hole in the fastening portion is constructed of a boss projected toward a back side of the fastening portion.

7. The outer rotor type motor as claimed in claim 5, wherein each of the upper insulator and the lower insulator includes a supporting rib on an inside along a circumferential direction thereof in contact with the stator core for supporting an inside surface of the core.

8. The outer rotor type motor as claimed in claim 5, wherein the fastening portion of each of the upper insulator and the lower insulator includes at least one reinforcing rib connected between the boss of the fastening hole and the supporting rib for spreading fastening force concentrated on the boss and reinforcing a strength of the fastening portion.

9. The outer rotor type motor as claimed in claim 5, wherein the fastening portion of each of the upper insulator and the lower insulator includes at least one reinforcing rib connected between the bosses for spreading the fastening force concentrated on the boss, and reinforce a strength of the fastening portion.

10. The outer rotor type motor as claimed in claim 5, wherein each of the upper insulator and the lower insulator includes tips on opposite sidewalls of each of the Ts thereof having shapes in complementary to each other for fitting in at the time of assembly to form a flush surface.

11. The outer rotor type motor as claimed in claim 10, wherein the tips on opposite sidewalls of each of the Ts include "L" shape if the other side of the upper, and lower insulators includes a "┐" shape.

12. The outer rotor type motor as claimed in claim 10, further comprising tips having shape in complementary to each other at the opposite end surfaces substantially perpendicular to the opposite sidewall surfaces of the T of the upper insulator and the lower insulator.

13. The outer rotor type motor as claimed in claim 5, wherein the T of each of the upper insulator and the lower insulator includes a seating surface at an end for seating a core shoe of the stator core.

14. The outer rotor type motor as claimed in claim 5, wherein the fastening portion of the insulator includes a positioning projection in the vicinity of the fastening hole thereof having a shape in complementary to a positioning hole or slot in a fixing side, such as a tub.

15. The outer rotor type motor as claimed in claim 5, further comprising a cylindrical metal on an inside of the fastening hole.

16. The outer rotor type motor as claimed in claim 15, wherein the cylindrical metal is a spring pin having elasticity owing to a portion incised along a length direction of an outside surface.

17. The outer rotor type motor as claimed in claim 15, wherein the cylindrical metal is a hollow pin press fit in the fastening hole, the cylindrical metal having no incised portion.

18. The outer rotor type motor as claimed in claim 5, wherein each of the upper insulator and the lower insulator includes a land around the fastening hole.

19. An outer rotor type motor for a drum type washing machine comprising:

an annular stator core having multiple layers formed by winding a steel plate with a stripe shape of base portion and Ts projected from the base portion in a helix starting from a bottom layer to a top layer such that a layer overlaps with a next layer;

19

an upper insulator of an electric insulating material covered on an upper side of the stator core in a shape complementary to a shape of the stator core; and a lower insulator of an electric insulating material covered on a lower side of the stator core at the time of assembly with the upper insulator in a shape complementary to a shape of the stator core, wherein each of the upper insulator and the lower insulator includes three or more than three fastening portions formed as one body therewith projected from an inside of the upper and lower insulator toward a center of the stator for fastening the stator to a fixing side of the tub, the fastening portion has a boss of a fastening hole for securing the stator to a tub wall, and there is a cylindrical metal placed around the boss, and each of the fastening portions extends to contact an adjacent fastening portion.

20. The outer rotor type motor as claimed in claim **19**, wherein the stator core includes; multiple layers formed by winding in a helix starting from a bottom layer to a top layer, a plurality of Ts projected outwardly in a radial direction from the base portion of the stator core, and slots in the base portion of the stator core for reducing stress during winding the core.

21. An outer rotor type motor for a drum type washing machine comprising:

a stator core stacked by winding in a helix; an insulator of an insulating material having an upper side piece, and a lower side piece to cover the core when the upper side piece, and the lower side piece are joined together;

coils wound on the Ts of the stator core respectively; and fastening portions formed as one body with the insulator, each of the fastening portions includes an extended portion extended to an inside of the insulator, and a projected portion projected toward an inside again from the extended portion, wherein the fastening portions are formed to continuously extend from an upper end of the stator core to a lower end of the stator core.

22. The outer rotor type motor as claimed in claim **21**, wherein the stator core includes;

multiple layers formed by winding in a helix starting from a bottom layer to a top layer, a plurality of Ts projected outwardly in a radial direction from the base portion of the stator core, and slots in the base portion of the stator core for reducing stress during winding the core.

23. The outer rotor type motor as claimed in claim **21**, wherein the multiple layers are fastened by rivets passed through pass through holes in the base portion.

24. The outer rotor type motor as claimed in claim **22**, wherein the bottom layer and the top layer of the stator core are welded to predetermined portions of the base portion, respectively.

25. An outer rotor type motor for a drum type washing machine comprising:

an annular stator core having multiple layers formed by winding a steel plate with a stripe shape of base portion and Ts projected from the base portion in a helix starting from a bottom layer to a top layer such that a layer overlaps with a next layer;

an upper insulator of an electric insulating material covered on an upper side of the stator core in a shape complementary to a shape of the stator core; and a lower insulator of an electric insulating material covered on a lower side of the stator core at the time of assembly with the upper insulator in a shape complementary to a shape of the stator core;

20

annular supporters respectively inserted in the upper insulator and the lower insulator;

wherein each of the upper insulator and the lower insulator, and the supporters inserted therein, includes fastening portions projected from an inside of the upper and lower insulator toward a center of the stator for fastening the stator to a fixing side of the tub, and the fastening portion has a fastening hole for securing the stator to a tub wall with fastening members, and each of the fastening portions extends to contact with an adjacent fastening portion.

26. The outer rotor type motor as claimed in claim **25**, wherein the base portion of the stator core includes slots for reducing stress during winding the core.

27. The outer rotor type motor as claimed in claim **25**, wherein the fastening hole in the fastening portion is constructed of a boss projected from a back side of the fastening portion.

28. The outer rotor type motor as claimed in claim **25**, wherein each of the upper insulator and the lower insulator includes a supporting rib on an inside along a circumferential direction thereof in contact with the stator core for supporting an inside surface of the core.

29. The outer rotor type motor as claimed in claim **25**, wherein the fastening portion of each of the upper insulator and the lower insulator includes at least one reinforcing rib connected between the boss of the fastening hole and the supporting rib for spreading fastening force concentrated on the boss and reinforcing a strength of the fastening portion.

30. The outer rotor type motor as claimed in claim **25**, wherein the fastening portion of each of the upper insulator and the lower insulator includes at least one reinforcing rib connected between the bosses for spreading the fastening force concentrated on the boss, and reinforce a strength of the fastening portion.

31. The outer rotor type motor as claimed in claim **25**, further comprising tips having shape in complementary to each other at the opposite end surfaces substantially perpendicular to the opposite sidewall surfaces of the T of the upper insulator and the lower insulator.

32. The outer rotor type motor as claimed in claim **31**, wherein the tips on opposite sidewalls of each of the Ts include "L" shape if the other side of the upper, and lower insulators includes a "┐" shape.

33. The outer rotor type motor as claimed in claim **25**, wherein the T of each of the upper insulator and the lower insulator includes a seating surface at an end for seating a core shoe of the stator core.

34. The outer rotor type motor as claimed in claim **25**, wherein the fastening portion of the insulator includes a positioning projection in the vicinity of the fastening hole thereof having a shape in complementary to a positioning hole or slot in a fixing side, such as a tub.

35. The outer rotor type motor as claimed in claim **25**, further comprising a metal tube or a spring pin on an inside of the fastening hole.

36. The outer rotor type motor as claimed in claim **25**, wherein each of the upper insulator and the lower insulator includes a land around the fastening hole.

37. An outer rotor type motor for a drum type washing machine comprising:

a stator core stacked by winding in a helix;

an insulator of an insulating material having an upper side piece, and a lower side piece to cover the core when the upper side piece, and the lower side piece are joined together;

21

an annular supporter of metal inserted in at least one of the upper insulator and the lower insulator; and fastening portions formed as one body with the upper, and lower insulators, and/or the supporter inserted therein, each of the fastening portions being projected from an inside of the upper and lower insulator toward a center thereof for securing the stator to a fixing side of the tub, and the fastening portions are formed to continuously extend from an upper end of the stator core to a lower end of the stator core.

22

38. The outer rotor type motor as claimed in claim 37, wherein the stator core includes; multiple layers formed by winding in a helix starting from a bottom layer to a top layer, a plurality of Ts projected outwardly in a radial direction from the base portion of the stator core, and slots in the base portion of the stator core for reducing stress during winding the core.

* * * * *