

US007290901B2

(12) **United States Patent**
Sotokawa et al.

(10) **Patent No.:** **US 7,290,901 B2**
(45) **Date of Patent:** ***Nov. 6, 2007**

(54) **LIGHT SOURCE DEVICE, AND DISPLAY DEVICE, DISPLAY MODULE, INFORMATION HANDLING APPARATUS AND PORTABLE INFORMATION HANDLING APPARATUS COMPRISING SAME**

(75) Inventors: **Akio Sotokawa**, Kawasaki (JP); **Seiji Hachisuka**, Kawasaki (JP)

(73) Assignee: **Fujitsu Limited**, Kawasaki (JP)

(*) Notice: Subject to any disclaimer, the term of this patent is extended or adjusted under 35 U.S.C. 154(b) by 0 days.

This patent is subject to a terminal disclaimer.

(21) Appl. No.: **11/315,232**

(22) Filed: **Dec. 23, 2005**

(65) **Prior Publication Data**

US 2006/0098436 A1 May 11, 2006

Related U.S. Application Data

(63) Continuation of application No. 10/663,708, filed on Sep. 17, 2003, now Pat. No. 7,070,291, which is a continuation of application No. PCT/JP02/02622, filed on Mar. 19, 2002.

(30) **Foreign Application Priority Data**

Mar. 19, 2001 (JP) 2001-078546

(51) **Int. Cl.**
F21V 29/00 (2006.01)

(52) **U.S. Cl.** **362/263**; 362/264; 362/218; 362/294

(58) **Field of Classification Search** 362/31, 362/263, 264, 218, 561, 294, 217
See application file for complete search history.

(56) **References Cited**

U.S. PATENT DOCUMENTS

3,379,868 A	4/1968	Taillon
3,636,341 A	1/1972	Miller
3,917,971 A	11/1975	Muzeroll
4,866,327 A	9/1989	Fischer et al.
4,914,553 A	4/1990	Hamada et al.
4,924,368 A	5/1990	Northrop et al.

(Continued)

FOREIGN PATENT DOCUMENTS

EP	0 276 888 A2	8/1988
----	--------------	--------

(Continued)

OTHER PUBLICATIONS

Information List (Form 1)—List of Prior Arts date Mar. 23, 2007.

(Continued)

Primary Examiner—Laura Tso

(74) *Attorney, Agent, or Firm*—Westerman, Hattori, Daniels & Adrian, LLP.

(57) **ABSTRACT**

A light source device includes a discharge tube, a reflector for reflecting a light radiated from the discharge tube, and support members for supporting the discharge tube to the reflector. The support member or the discharge tube is formed of a heat insulating structure so as to prevent a temperature drop of a portion of the discharge tube near electrodes thereof. By this arrangement, it is possible to prolong the operational life of the discharge tube.

18 Claims, 6 Drawing Sheets

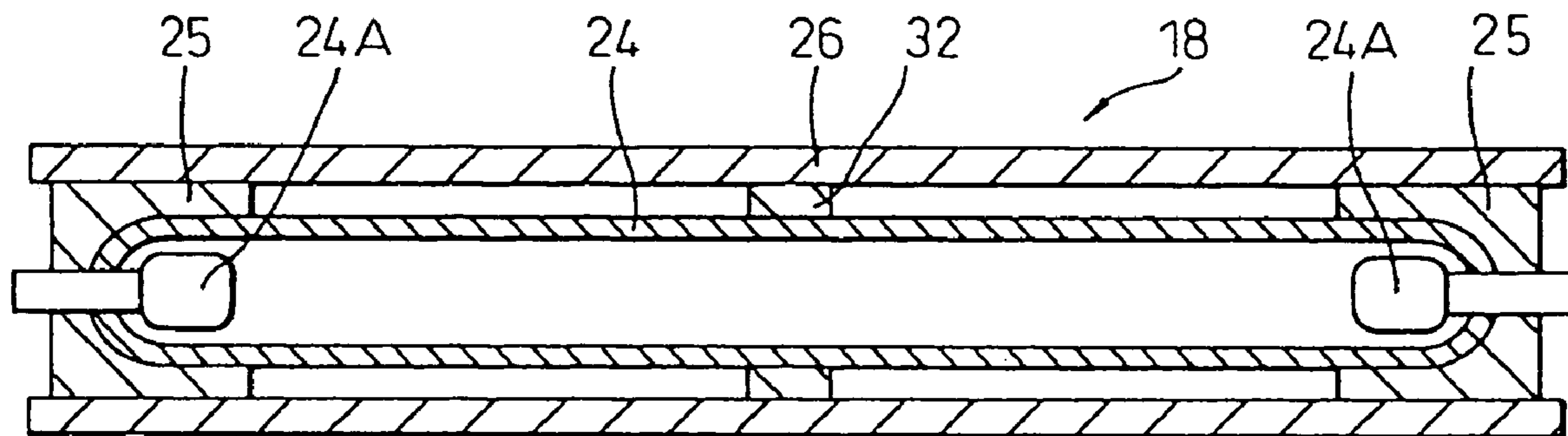

US 7,290,901 B2

Page 2

U.S. PATENT DOCUMENTS

5,291,379 A 3/1994 Lu
5,697,696 A 12/1997 Kuroda et al.
6,147,724 A 11/2000 Yoshii et al.
6,254,244 B1 7/2001 Ukai et al.
7,070,291 B2* 7/2006 Sotokawa et al. 362/632
2002/0113534 A1 8/2002 Hayashi et al.

JP 10-333149 A 12/1998
JP 11-84381 3/1999
JP 11-149815 A 6/1999
JP 11-295734 A 10/1999
JP 2000-123788 4/2000
JP 2000-173542 A 6/2000
JP 2000-214461 A 8/2000

FOREIGN PATENT DOCUMENTS

EP 0 389 280 A1 9/1990
JP 4-67626 U 6/1992
JP 7-288019 10/1995
JP 07-325302 A 12/1995
JP 8-55608 2/1996
JP 10-106315 A 4/1998

OTHER PUBLICATIONS

European Search Report dated Mar. 15, 2007, issued in corresponding European Application No. 02 70 5359.
United States Patent and Trademark Office PTO/892 dated Mar. 30, 2006, issued in corresponding US Appl. No. 11,315,231.

* cited by examiner

Fig. 1

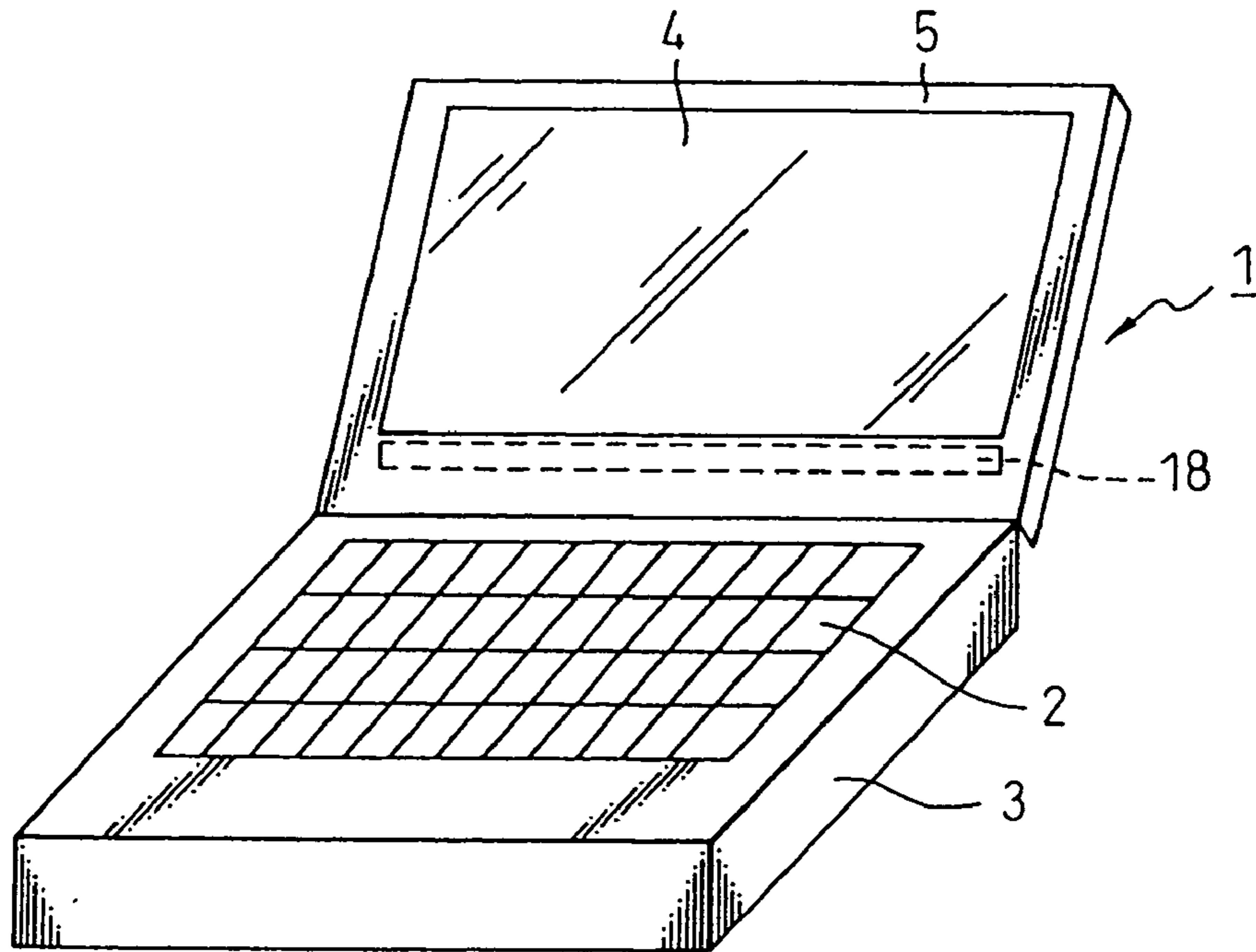

Fig. 2

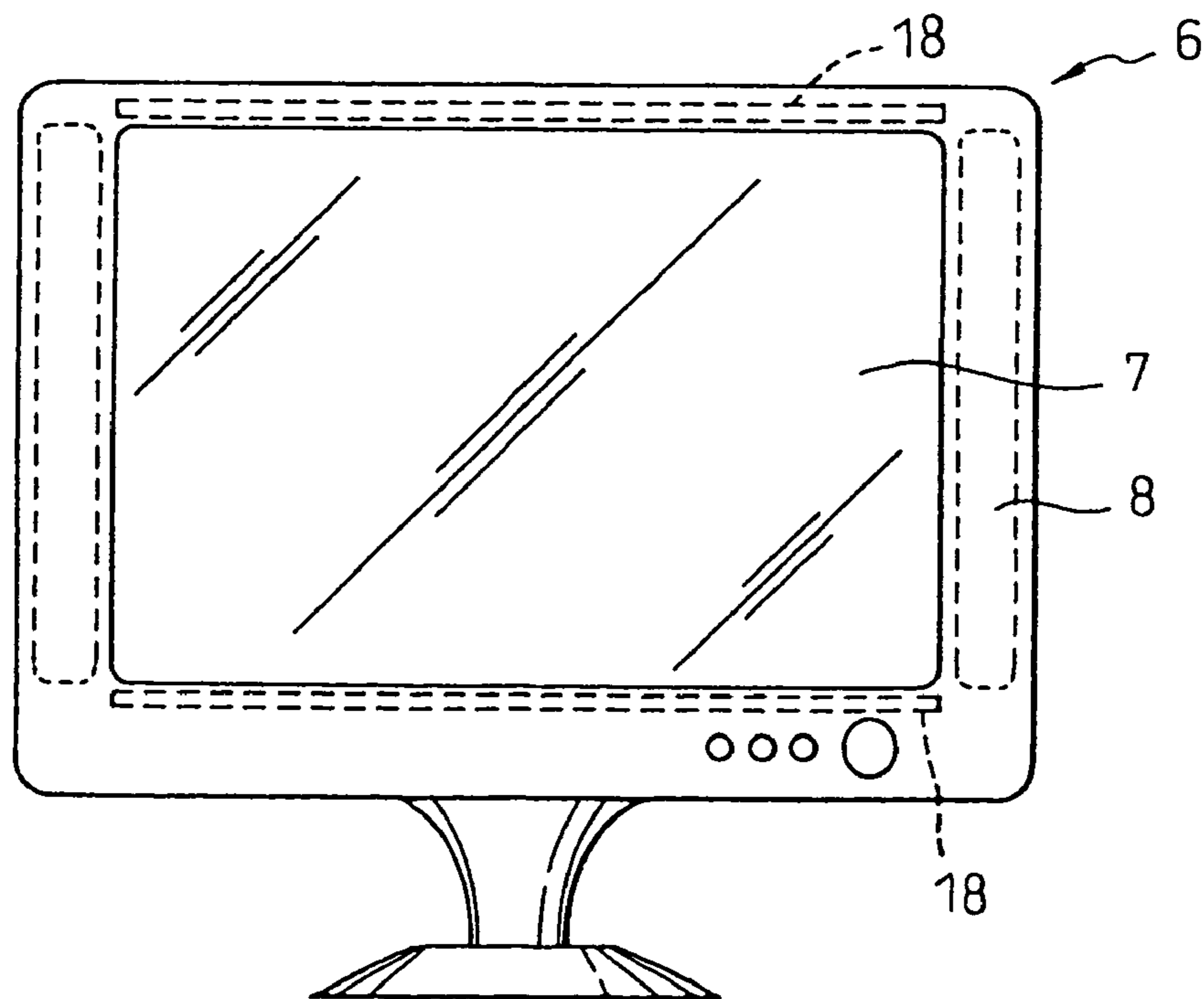

Fig. 3

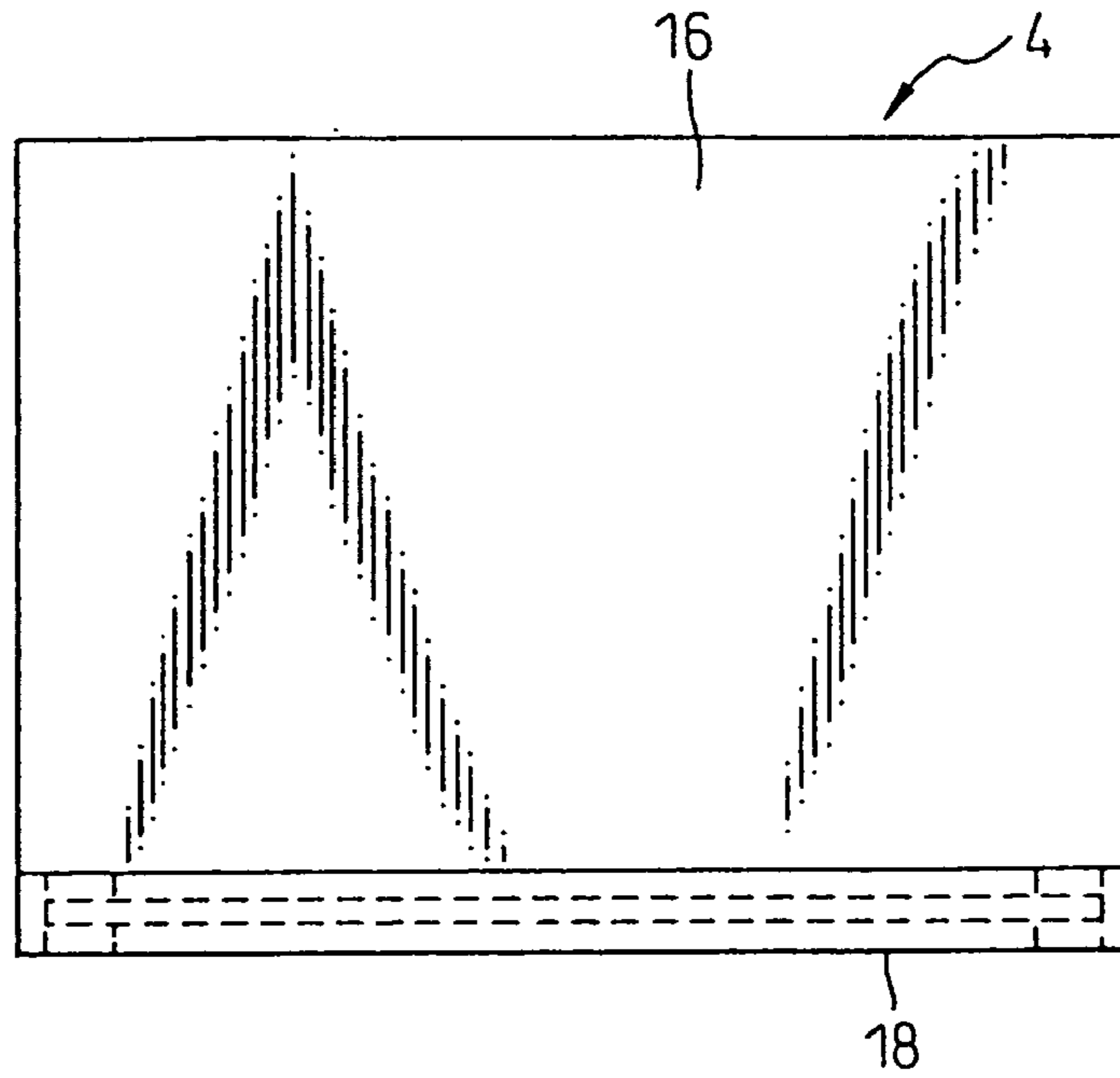

Fig. 4

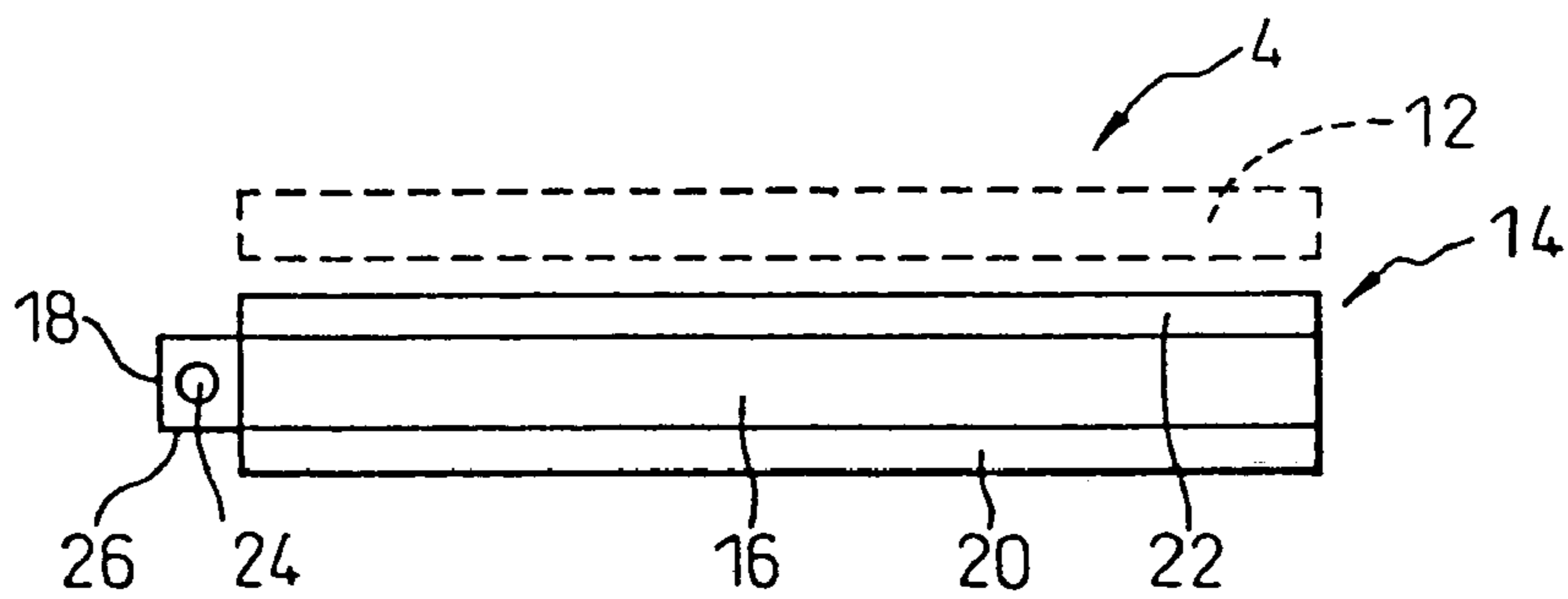

Fig. 5

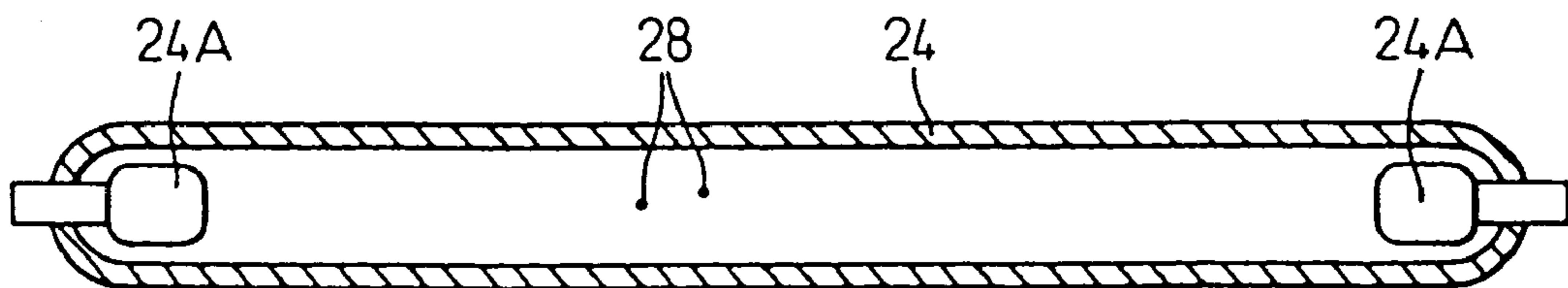

Fig. 6

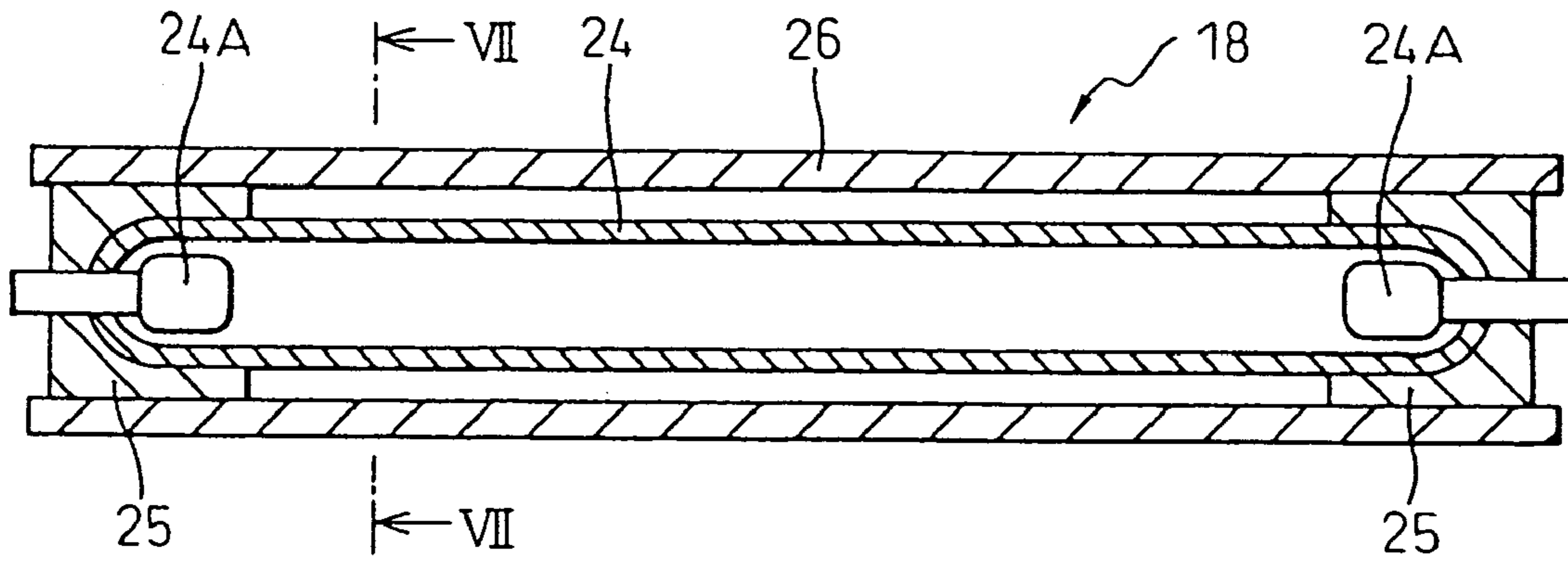

Fig. 7

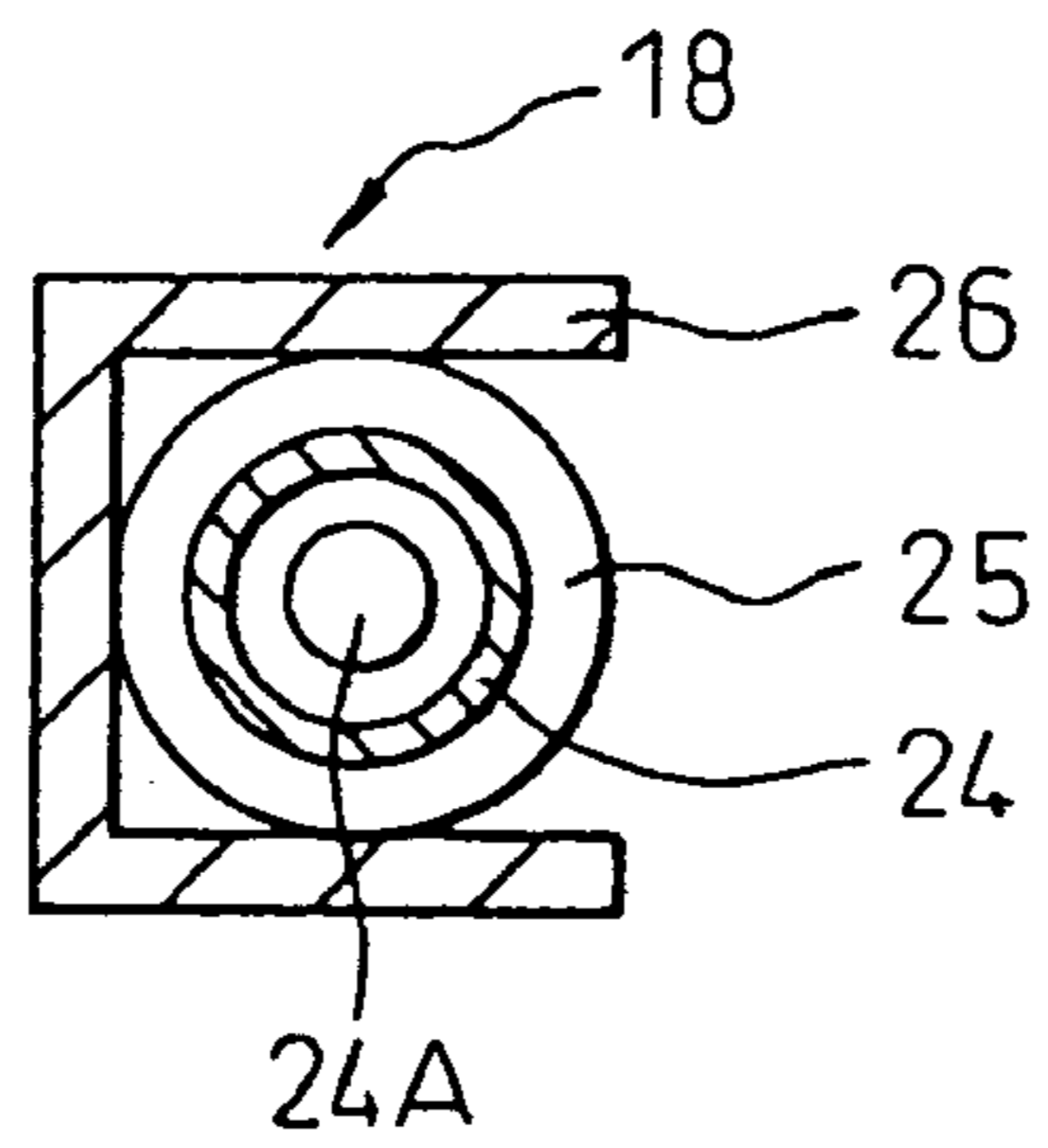

Fig. 8

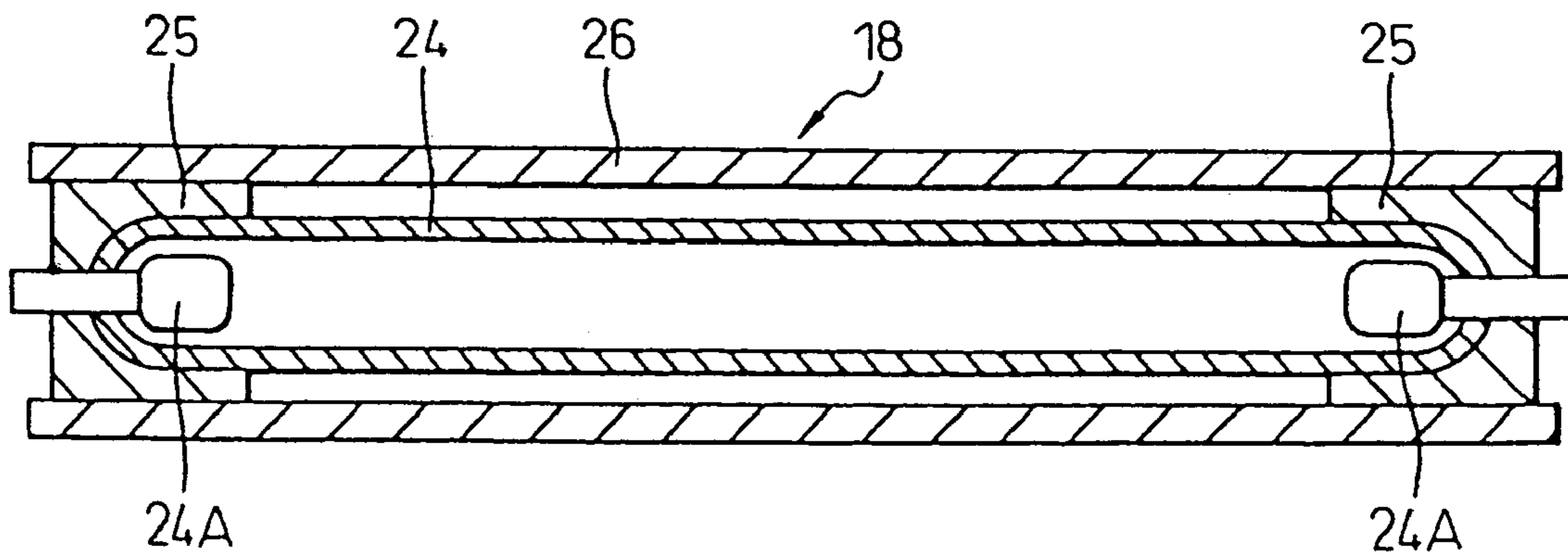

Fig. 9

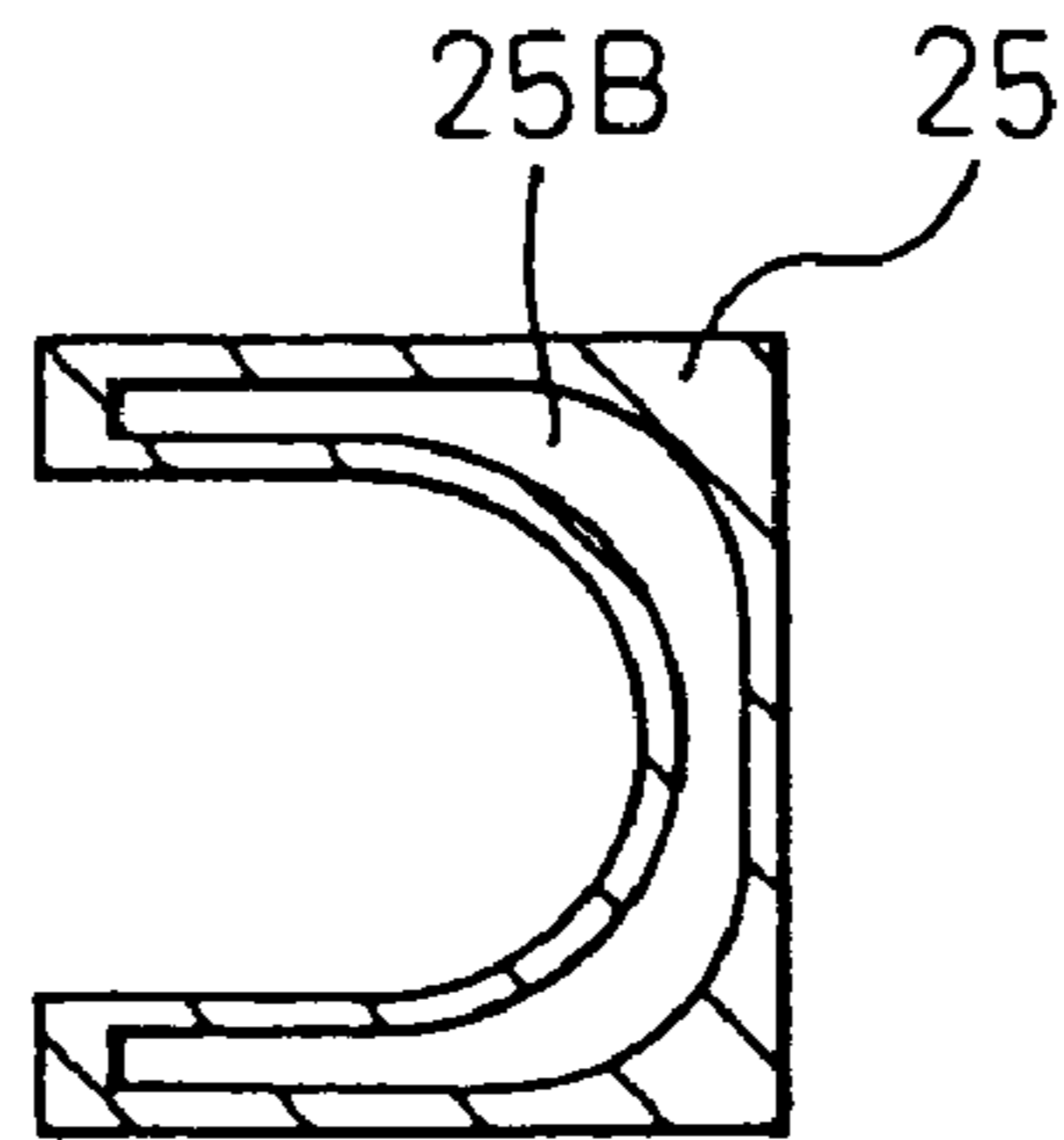

Fig. 10

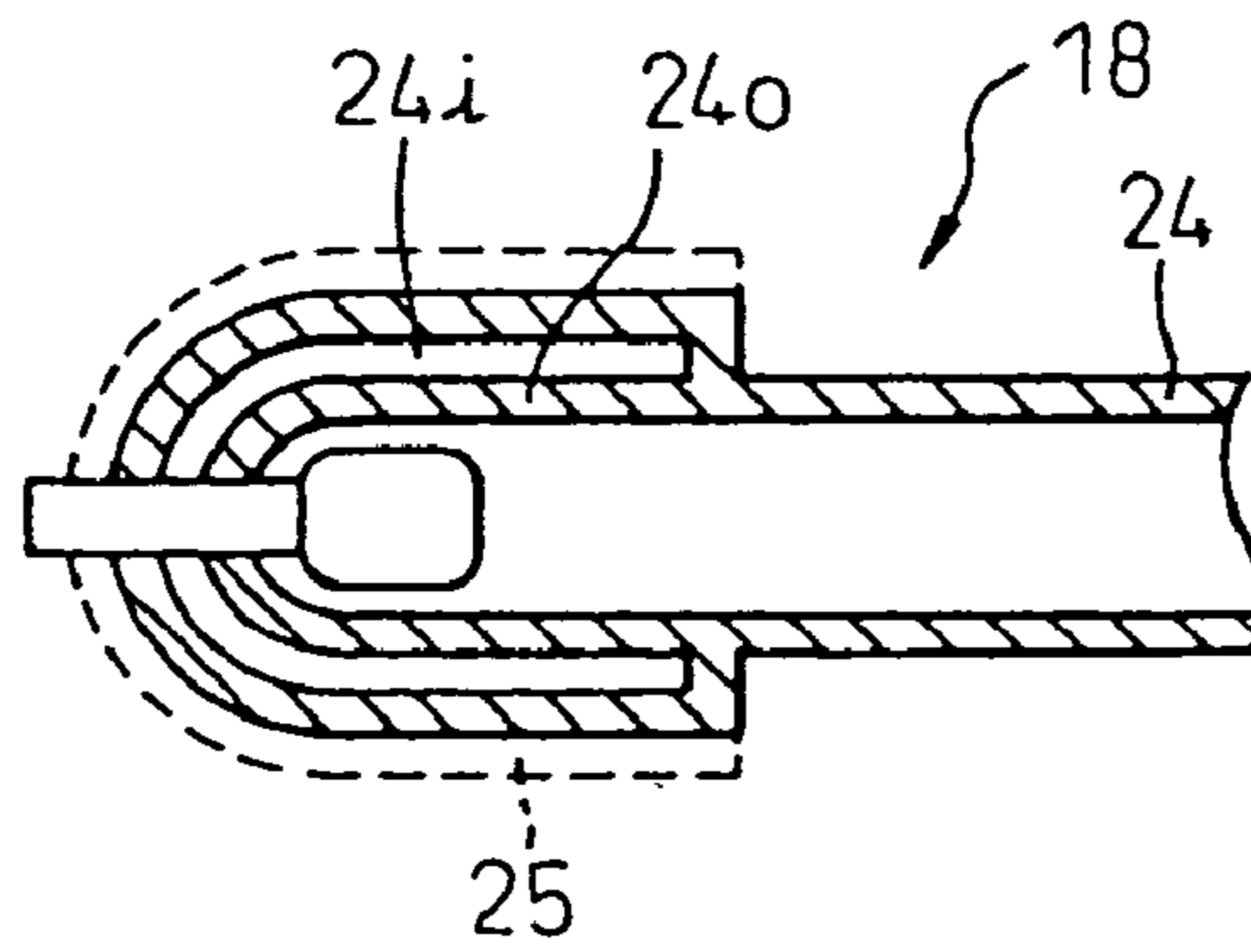

Fig. 11

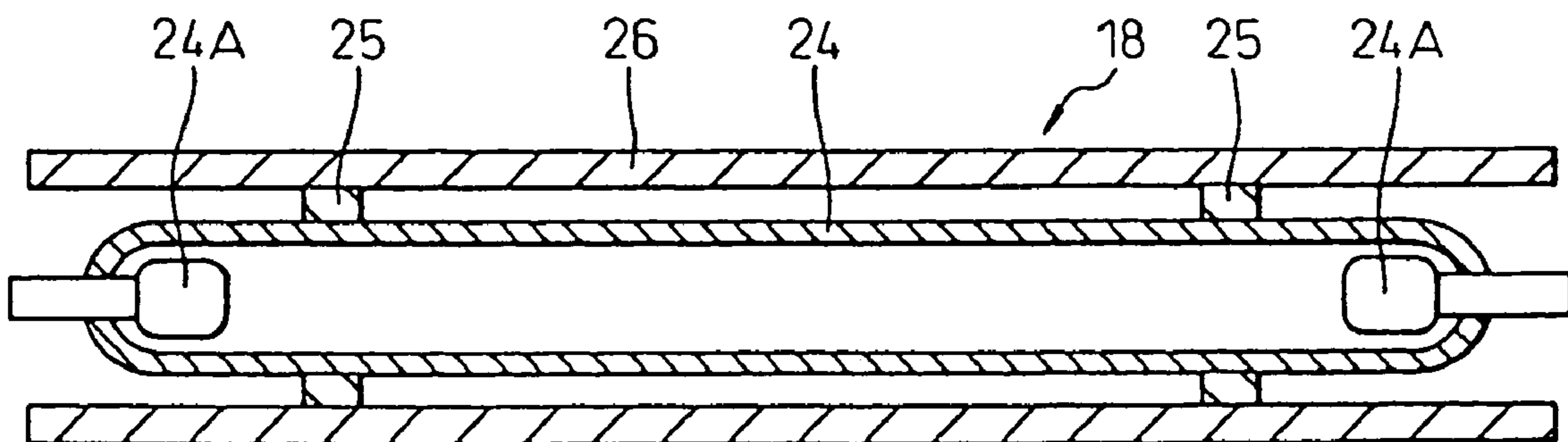

Fig.12

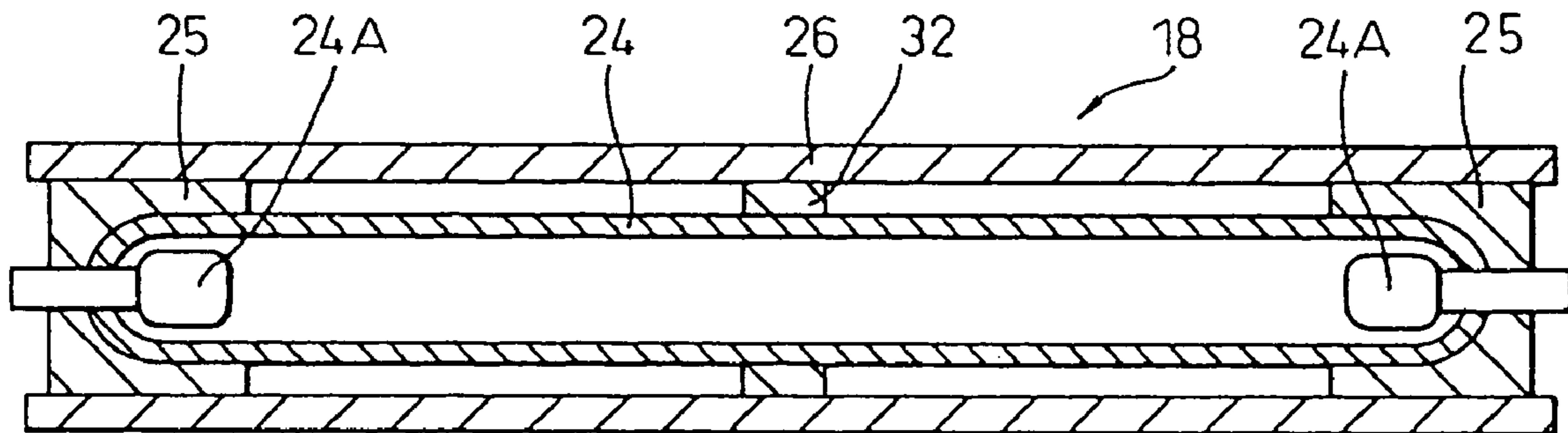

Fig.13

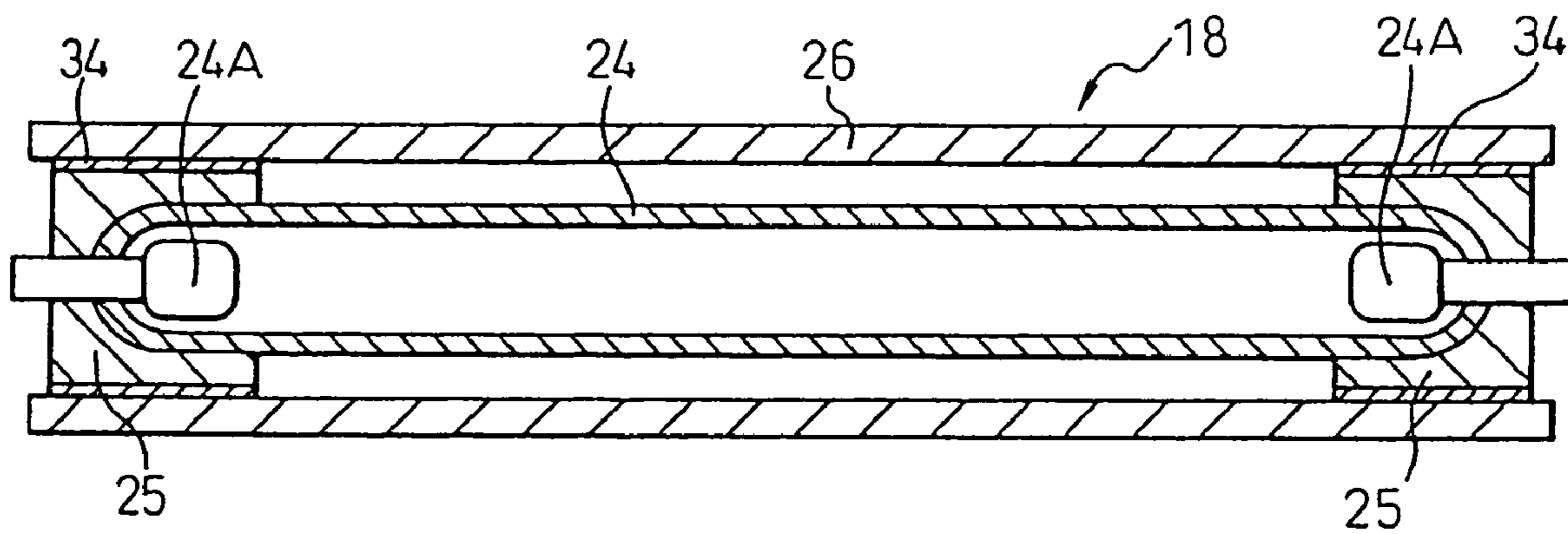

Fig.14

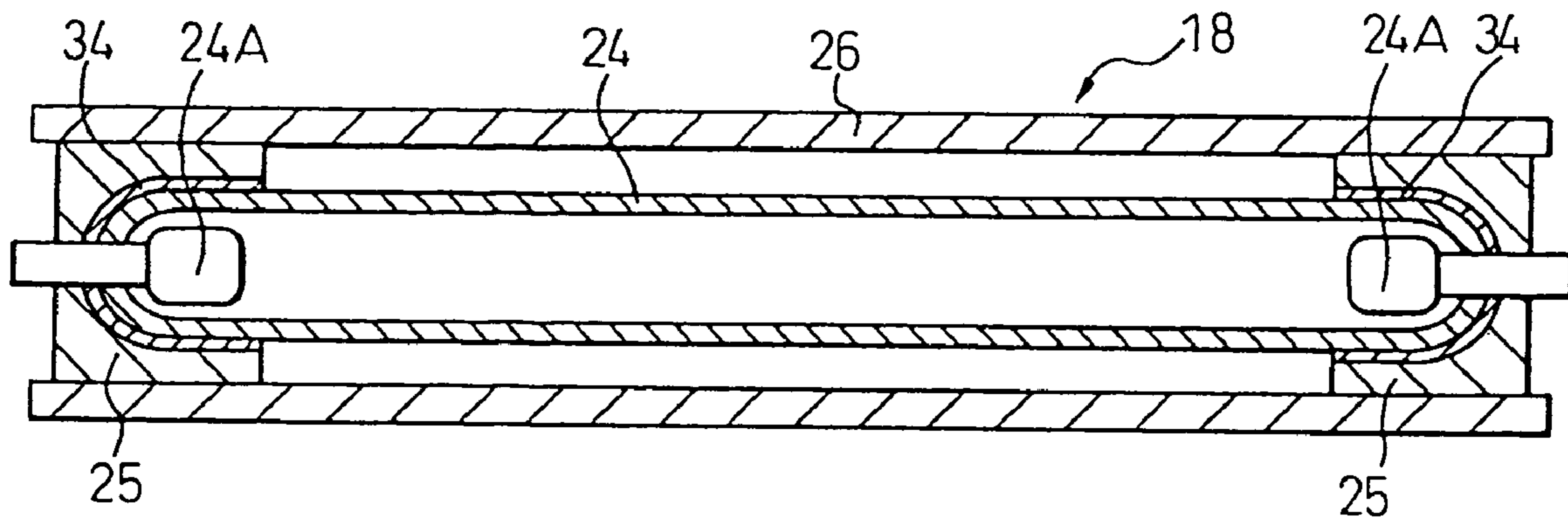
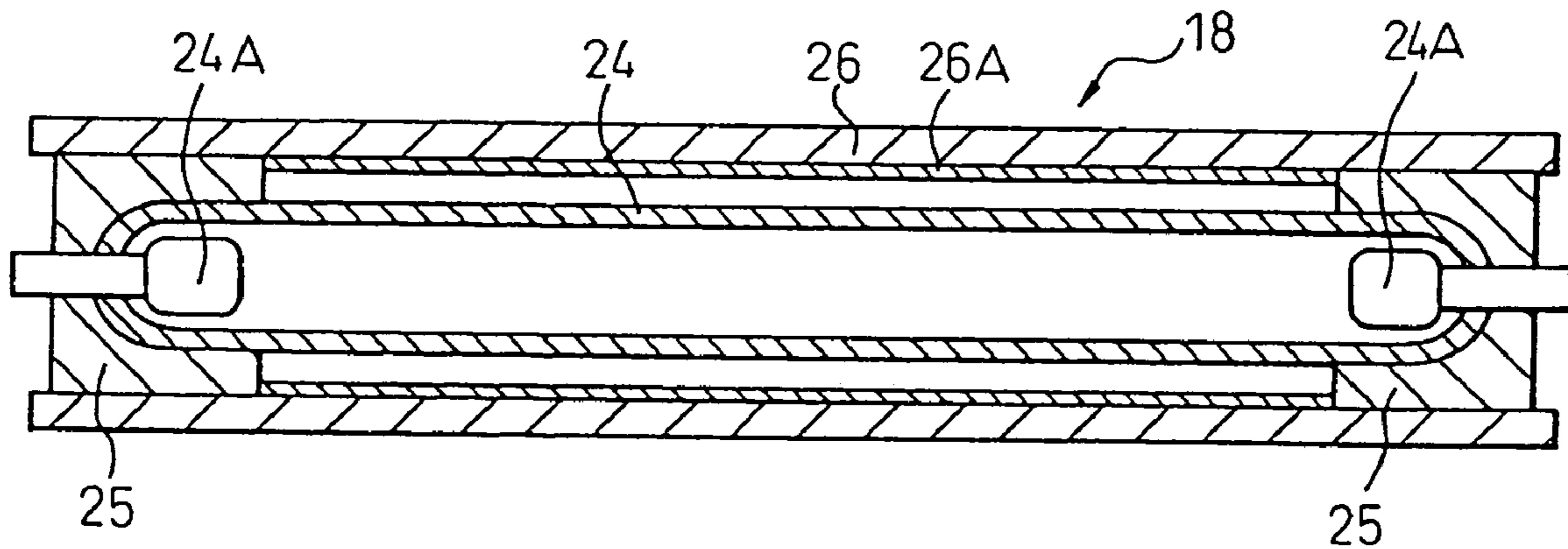

Fig.15



1

**LIGHT SOURCE DEVICE, AND DISPLAY
DEVICE, DISPLAY MODULE,
INFORMATION HANDLING APPARATUS
AND PORTABLE INFORMATION
HANDLING APPARATUS COMPRISING
SAME**

This application is a continuation of application Ser. No. 10/663,708, filed on Sep. 17, 2003 now U.S. Pat. No. 7,070,291, which is a continuation of PCT/JP 02/02622 filed Mar. 19, 2002, which claims the priority of Japanese Application No. 2001-078546 filed Mar. 19, 2001, which is incorporated herein by reference.

TECHNICAL FIELD

The present invention relates to a light source device having a discharge tube emitting light by a discharge in a lean gas.

BACKGROUND ART

A backlight, as a light source device of a display device such as a liquid crystal display device, uses a light source device comprising one or a plurality of discharge tubes and a reflector. The discharge tube is a cold cathode tube, in which mercury is contained in a lean gas (such as Ar and Ne) and a fluorescent material is coated on the tube wall. Electrodes are provided in both ends of the discharge tube. The discharge tube is supported by the reflector with support members which are arranged at positions near the electrodes of the discharge tube. The backlight also has a light guide plate, and the light source device is arranged on the side of the light guide plate.

When the high voltage is applied to the electrodes of the discharge tube, electrons are emitted by the electrodes and impinge against the mercury gas in the discharge tube. The mercury gas produces ultraviolet light, which impinges against the fluorescent material in the discharge tube to emit visible light. As the amount of the mercury gas in the discharge tube is reduced, the amount of emitted light is reduced and an operational life thereof ends. Usually, a sufficient amount of mercury gas is sealed in the discharge tube to enable the discharge tube to have a long life, but there are discharge tubes having extremely short operational lives.

SUMMARY OF THE INVENTION

The object of the present invention is to provide a light source device capable of a long operational life of a discharge tube.

A light source device, according to the first aspect of the present invention, comprises a discharge tube, a reflector for reflecting a light radiated from the discharge tube, and support members for supporting the discharge tube to the reflector, said support members being formed of a heat insulating structure so as to prevent a temperature drop of a portion of the discharge tube near electrodes of the discharge tube.

A light source device, according to the second aspect of the present invention, comprises a discharge tube, a reflector for reflecting a light radiated from the discharge tube, and support members for supporting the discharge tube to the reflector, the discharge tube being formed of a partially heat insulating structure so as to prevent a temperature drop of a portion of the discharge tube near electrodes of the discharge tube.

2

A light source device, according to the third aspect of the present invention, comprises a discharge tube, a reflector for reflecting a light radiated from the discharge tube, and support members for supporting the discharge tube to the reflector, the support members being arranged at positions inward from ends of electrodes of the discharge tube so as to prevent a temperature drop of a portion of the discharge tube near electrodes of the discharge tube.

A light source device, according to the fourth aspect of the present invention, comprises a discharge tube, a reflector for reflecting a light radiated from the discharge tube, support members for supporting the discharge tube to the reflector, and a heat conduction member contacting a central portion of the discharge tube.

In these arrangements, generally, the operating life of the discharge tube will end if the mercury contained in the discharge tube is consumed. Consumption of mercury occurs in such a manner that gaseous mercury in the discharge tube reacts with particles of metal of the electrodes (for example, Ni) caused by sputtering with electrons and is adhered to and captured by the inner surface of the discharge tube. A sufficiently large amount of mercury is usually inserted in the discharge tube, it takes much time for mercury to be consumed and, therefore, the operating life of the discharge tube is guaranteed to some extent.

However, there are several discharge tubes among many discharge tubes which have extremely short operating life. According to the inventor's study, the extremely short operating life is caused by the following reason. That is, a portion of the discharge tube near the electrodes is primarily a portion at which the largest amount of heat is generated and the temperature is higher, but in the structure in which the discharge tube is supported to the reflector by the support members, heat of the discharge tube is thermally conducted to the reflector through the support members and further from the reflector to the housing of the display device, so that the temperature of the portion of the discharge tube near the electrodes becomes the lowest within the discharge tube. Also, the support members are arranged at positions near the electrodes of the discharge tube, the reflector is generally made of metal, and the support members are made of silicone so as to withstand the high voltage applied to the electrodes. Therefore, heat of the discharge tube is liable to be conducted to the reflector through the support members.

Mercury exists in the discharge tube in a gaseous state as well as in a non-gaseous state (liquid or solid). The liquid mercury is collected at the lowest temperature point in the discharge tube (because a concentration gradient is produced because of a difference in a saturated vapor pressure due to a temperature difference, mercury is conveyed by diffusion). Particles of metal of the electrodes caused by sputtering with electrons are deposited on the thus collected liquid mercury, and produces a thin membrane on the liquid mercury. This membrane prevents the mercury from evaporating, and the amount of the gaseous mercury in the discharge tube is reduced. If the amount of the gaseous mercury is reduced, the discharge tube becomes dark and the operating life thereof is short.

Accordingly, in the present invention, a shortened operational life of the discharge tube is prevented by adopting the above-described arrangements so that the portion of the discharge tube near the electrodes of the discharge tube does not become the lowest temperature point and so that the liquid mercury is not captured and enclosed by the particles of metal of the sputtered electrodes, whereby the amount of the gaseous mercury is not reduced.

The above-described light source device can be used as a light source device of an information processing apparatus and a display device.

Further, the present invention provides an information processing apparatus comprising a light source device and a light valve receiving a light emitted by the light source device, the light source device including a discharge tube, a reflector for reflecting a light radiated from the discharge tube, support members for supporting the discharge tube to the reflector, and a layer of heat insulating material arranged between the discharge tube and the support member or between the support member and the reflector.

Further, the present invention provides a display device comprising a light source device and a light valve receiving a light illuminated by the light source device, the light source device including a discharge tube, a reflector for reflecting a light radiated from the discharge tube, support members for supporting the discharge tube to the reflector, and a layer of heat insulating material arranged between the discharge tube and the support member or between the support member and the reflector.

Further, the present invention provides a light source device comprising a discharge tube, a reflector for reflecting a light radiated from the discharge tube, and support members for supporting the discharge tube to the reflector, the reflector being made of a resin.

BRIEF DESCRIPTION OF THE DRAWINGS

In the drawings:

FIG. 1 is a view showing the notebook type personal computer including the light source device according to the present invention;

FIG. 2 is a view showing the display device including the light source device of the present invention;

FIG. 3 is a plan view of the light guide plate and the light source device of the display device of FIG. 1;

FIG. 4 is a sectional view of the light guide plate and the light source device of FIG. 3;

FIG. 5 is a sectional view showing the discharge tube;

FIG. 6 is a sectional view of the light source device including the discharge tube and the reflector;

FIG. 7 is a sectional view of the light source device, taken along the line VII-VII in FIG. 6;

FIG. 8 is a sectional view of the light source device including the discharge tube and the reflector according to another example;

FIG. 9 is a sectional view of the support member of FIG. 8;

FIG. 10 is a sectional view of the light source device including the discharge tube and the reflector according to a further example;

FIG. 11 is a sectional view of the light source device including the discharge tube and the reflector according to a further example;

FIG. 12 is a sectional view of the light source device including the discharge tube and the reflector according to a further example;

FIG. 13 is a sectional view of the light source device including the discharge tube and the reflector according to a further example;

FIG. 14 is a sectional view of the light source device including the discharge tube and the reflector according to a further example; and

FIG. 15 is a sectional view of the light source device including the discharge tube and the reflector according to a further example.

BEST MODE FOR CARRYING OUT THE INVENTION

Embodiments of the present invention will be explained hereinafter with reference to the accompanying drawings. FIG. 1 is a view showing the notebook type personal computer including the light source device according to the embodiment of the present invention, and FIG. 2 is a view showing the display device including the light source device according to the present invention.

In FIG. 1, the notebook type personal computer 1 comprises a body 3 having a keyboard 2 and electronic circuits, and a display part 5 having a display 4 such as a liquid crystal display device. The display part 5 has a light source device 18. The notebook type personal computer 1 of FIG. 1 includes one light source device 18, but it is possible to arrange two light source devices 18, as in the case of the display device 6 of FIG. 2.

In FIG. 2, the display device 6 comprises a body 8 having a display 7 such as a liquid crystal display device and electronic circuits. The body 8 has light source devices 18. The display device 6 of FIG. 2 includes two light source devices 18, but it is possible to arrange one light source device 18, as in the case of the notebook type personal computer 1 of FIG. 1.

FIG. 3 is a plan view of the light guide plate and the light source device of the display 4 of FIG. 1, and FIG. 4 is a sectional view of the light guide plate and the light source device of FIG. 3. In FIGS. 3 and 4, the display 4 includes a liquid crystal display panel 12 and a backlight 14. The backlight 14 includes a light guide plate 16, the light source devices 18 arranged at the side of the light guide plate 16, a scattering reflection plate 20 arranged below the light guide plate 16, and a scattering plate 22 arranged above the light guide plate 16.

The light source device 18 comprises a discharge tube 24 and a reflector 26. A part of the light emitted by the discharge tube 24 is made directly incident to the light guide plate 16, and another part of the light outgoing from the discharge tube 24 is reflected by the reflector 26 to be made incident to the light guide plate 16. The light travels within the light guide plate 16, is reflected by the scattering reflection plate 20 to leave the light guide plate 16 toward the liquid crystal display panel 12, and is made incident to the liquid crystal display panel 12 after being scattered by the scattering plate 22. The liquid crystal display panel 12 forms an image, and the light supplied from the light source device 14 illuminates the image formed by the liquid crystal display panel 12, so that a viewer can see a bright image.

FIG. 5 is a sectional view showing the discharge tube 24, and FIG. 6 is a sectional view showing the light source device 18 including the discharge tube 24 and the reflector 26. FIG. 7 is a sectional view of the light source device 18, taken along the line VII-VII in FIG. 6. The discharge tube 24 comprises a cold-cathode tube called a fluorescent lamp. Electrodes 24A made of metal such as Ni or W are arranged in the ends of the discharge tube 24. Lean gas (such as Ar or Ne) and mercury 28 are inserted and sealed in the discharge tube 24, and a fluorescent material is coated on the inner surface of the discharge tube 24. The reflector 26 comprises an aluminum mirror, for example, and has a cross-sectional shape such a U-shape to cover the discharge tube 24.

Support members 25 are arranged on the discharge tube 24 near the electrodes 24A for supporting the discharge tube 24 to the reflector 26. The inner surface of the support member 25 is in close contact with the discharge tube 24, and the outer surface of the support member 25 is in close

5

contact with the reflector 26. A portion of the electrode 24A is within the discharge tube 24, and another portion of the electrode 24A extends to the exterior of the discharge tube 24 through the end of the discharge tube 24 and the end of the support member 25.

The support member 25 is formed of a heat insulating structure so as to prevent a temperature drop of a portion of the discharge tube 24 near the electrode 24A. In this embodiment, the support member 25 is made of a material having high heat insulating property and high voltage withstanding property. For example, the support member 25 is made of Aramid fiber. The support member 25 can be made of glass wool.

In the structure in which the discharge tube 24 is supported by the reflector 26 with the support members 25, there is a tendency that heat of the discharge tube 24 is thermally conducted to the reflector 26 through the support members 25, and further from the reflector 26 to the housing of the display device, so that the temperature of a portion of the discharge tube 24 near the electrodes 24A may be reduced.

Conventional support members are made of silicone so as to withstand the high voltage applied to the electrodes, and the heat of the discharge tube 24 is thermally conducted to the reflector 26 through the support members 25, because silicone has a good heat conductivity, so that the temperature of the portion of the discharge tube 24 near the electrodes 24A may be possibly reduced to the lowest value. Therefore, liquid mercury is collected at the portion of the discharge tube 24 near the electrodes 24A where the temperature is lowest, resulting in the reduction of the amount of gaseous mercury and a short life of the discharge tube 24.

In the present invention, the support member 25 is formed of a highly heat insulating material, so the heat of the discharge tube 24 is not so much thermally-conducted to the reflector 26 through the support members 25, and the temperature of the portion of the discharge tube 24 near the electrodes 24A is not reduced to the lowest value. The portion of the discharge tube 24 near the electrodes 24A is a portion at which the amount of the generated heat is primarily maximum and the temperature is higher, and the position at which the temperature becomes lowest in the discharge tube 24 is shifted toward the center from the region in which the support member 25 extends. Therefore, liquid mercury is not collected at the portion of the discharge tube 24 near the electrodes 24A.

On the other hand, metal of the electrodes 24A of the discharge tube 24 is sputtered with electrons during discharge and particles of metal of the electrodes 24A are deposited on the inner surface of the discharge tube 24. The region in which particles of metal of the electrodes 24A are deposited on the inner surface of the discharge tube 24 is limited to the region within a restricted distance from the end of the electrode 24A. For example, in the case of the discharge tube 24 having the diameter of 5 mm, the region in which particles of metal of the electrodes 24A are deposited on the inner surface of the discharge tube 24 is within approximately 10 mm from the end of the discharge tube 24 or within 5 mm from the end of the electrode 24A.

Liquid mercury is not collected in the region in which particles of metal of the electrodes 24A are deposited, so liquid mercury is not captured by particles of metal. Therefore, according to the present invention, most liquid mercury can continue to evaporate and the amount of gaseous mercury is not reduced, so the operating life of the discharge tube 24 is not shortened.

6

FIG. 8 is a sectional view of the light source device 18 including the discharge tube 24 and the reflector 26 according to a modified embodiment, and FIG. 9 is a sectional view of the support member of FIG. 8. Support members 25 are arranged on the discharge tube 24 near the electrodes 24A for supporting the discharge tube 24 to the reflector 26. The support member 25 is formed of a heat insulating structure so as to prevent a temperature drop of a portion of the discharge tube 24 near the electrode 24A. In this embodiment, the support member 25 is made of silicone, similar to a conventional support member, but the support member 25 has a hollow portion 25B to realize a heat insulating structure. The operation of this embodiment is similar to that of the previous embodiment.

FIG. 10 is a sectional view of the light source device 18 including the discharge tube 24 and the reflector 26 (reflector 26 is omitted in FIG. 10) according to a modified embodiment. In this embodiment, the discharge tube 24 is partially formed of a heat insulating structure so as to prevent a temperature drop of a portion of the discharge tube 24 near the electrode 24A of the discharge tube 24. In other words, the end portion of the discharge tube 24 is formed in a double-tube structure having an outer tube portion 24o and an inner tube portion 24i, so that a heat insulation part comprising an air layer or a vacuum layer is provided between the outer tube portion 24o and the inner tube portion 24i. The support member 25 is arranged around the outer tube portion 24o and supports the discharge tube 24 to the reflector 26. The operation of this embodiment is similar to that of the previous embodiment.

FIG. 11 is a sectional view of the light source device 18 including the discharge tube 24 and the reflector 26 according to a modified embodiment. In this embodiment, the support members 25 are arranged at positions inward from the ends of electrodes 24A of the discharge tube 24 so as to prevent a temperature drop of a portion of the discharge tube 24 near the electrode 24A of the discharge tube 24. As described above, the region in which particles of metal of the electrodes 24A are deposited on the inner surface of the discharge tube 24 is limited to the region within a restricted distance from the end of the electrode 24A. The support members 25 are arranged on the outside of the regions in which particles of metal of the electrodes 24A are deposited (i.e., inward positions).

In this case, the support members 25 are not necessarily made of a heat insulating material, and are made of silicone, for example. Therefore, the temperature is lowest at the portion of the discharge tube 24 where the support members 25 are located due to the thermal conduction through the support members 25, as described above. However, as the lowest temperature portion of the discharge tube 24 is out of the region in which particles of metal of the electrodes 24A are deposited on the inner surface of the discharge tube 24, so liquid mercury is not captured by particles of metal. Therefore, according to the present invention, most liquid mercury can continue to evaporate and the amount of gaseous mercury is not reduced, so the operating life of the discharge tube 24 is not shortened.

FIG. 12 is a sectional view of the light source device 18 including the discharge tube 24 and the reflector 26 according to a modified embodiment. In this embodiment, the light source device 18 comprises support members 25 arranged at positions near electrodes 24A of the discharge tube 24 for supporting the discharge tube 24 to the reflector 26, and a heat conduction member 32 contacting a central portion of the discharge tube 24. The support members 25 are made of silicone. The heat conduction member 32 is made of silicone

having higher heat radiating property. Alternatively, it is possible to arrange fins on the heat conduction member **32** or to deliver cooling air from a fan.

The heat conduction member **32** also contacts the reflector **26** and releases the heat of the central portion of the discharge tube **24** to the reflector **26** to move the lowest temperature portion to the central portion of the discharge tube **24**. Therefore, liquid mercury is not collected to a portion of the discharge tube **24** near the electrodes **24A**, and liquid mercury is not captured by particles of metal. Therefore, according to the present invention, most liquid mercury can continue to evaporate and the amount of gaseous mercury is not reduced, so the operating life of the discharge tube **24** is not shortened.

Also, by moving the lowest temperature point to the center of the discharge tube **24**, mercury **28** evaporates mainly at the lower temperature portion and resultant gaseous mercury diffuses in the whole discharge tube **24**. The diffused gaseous mercury also returns to the lower temperature portion. In this way, gaseous mercury is uniformly distributed in the whole discharge tube **24**, and the temperature and the pressure of gaseous mercury are substantially uniform in the whole discharge tube **24**. That is, it is possible to control the temperature of gaseous mercury, by making the lower temperature point. The brightness of light emitted by the discharge tube **24** becomes maximum at the optimum concentration of gaseous mercury, and the corresponding temperature, in the discharge tube **24**, and the brightness of the light emitted by the discharge tube **24** is lower than the maximum value if the concentration of gaseous mercury is higher or lower than the optimum concentration or if the temperature in the discharge tube **24** is higher or lower than the optimum value. In this embodiment, it is possible to acquire the maximum brightness of the light emitted by the discharge tube **24**, by moving the lower temperature point in the discharge tube **24** to thereby set the temperature in the discharge tube **24** at or near the optimum value.

FIG. **13** is a sectional view of the light source device **18** including the discharge tube **24** and the reflector **26** according to a modified embodiment. Support members **25** are arranged at positions near the electrodes **24A** of the discharge tube **24** for supporting the discharge tube **24** to the reflector **26**. A layer of heat insulating material (heat insulating sheet) **34** is arranged between the discharge tube **24** and the reflector **26**. The discharge tube **24** is attached to the reflector **26**, with the layer of heat insulating material **34** bonded to the support member **25**. The support member **25** is made of silicone as in the conventional case, and the layer of heat insulating material **34** is made of meta-type Aramid fiber (Cornex from Teijin Corporation, for example). The support member **25** has a good heat conducting property, but the layer of heat insulating material **34** blocks the heat to thereby prevent the heat from escaping from the ends of the discharge tube **24** to the reflector **26**. Therefore, a temperature drop of a portion of the discharge tube **24** near the electrodes **24A** is prevented. The operation of this embodiment is identical to that of the previous embodiments.

FIG. **14** is a sectional view of the light source device **18** including the discharge tube **24** and the reflector **26** according to a modified embodiment. Support members **25** are arranged at positions near the electrodes **24A** of the discharge tube **24** for supporting the discharge tube **24** to the reflector **26**. A layer of heat insulating material (heat insulating sheet) **34** is arranged between the discharge tube **24** and the support member **25**. The support member **25** is made of silicone as in the conventional case, and the layer of heat insulating material **34** is made of meta-type Aramid fiber

(Cornex from Teijin Corporation, for example). The support member **25** has a good heat conducting property, but the layer of heat insulating material **34** blocks the heat to thereby prevent the heat from escaping from the ends of the discharge tube **24** to the reflector **26**. Therefore, a temperature drop of a portion of the discharge tube **24** near the electrodes **24A** is prevented. The operation of this embodiment is identical to that of the previous embodiments.

FIG. **15** is a sectional view of the light source device **18** including the discharge tube **24** and the reflector **26** according to a modified embodiment. In this embodiment, the reflector **26** is made of a heat insulating resin, for example, polycarbonate. Polycarbonate is a polyester resin of carbonic and polyhydric alcohol. Polycarbonate using aromatic alcohol has properties such as a higher melting point (superior to thermal stability), a higher mechanical strength, and a higher electric insulation. A reflection layer **26A** such as aluminum is coated on the inner surface of the reflector **26** so that it does not overlap with the support members **25**. Therefore, the support member **25** has a good heat conducting property, but the reflector **26** blocks the heat to thereby prevent the heat from escaping from the ends of the discharge tube **24** to the reflector **26** through the support members **25**. Therefore, a temperature drop of a portion of the discharge tube **24** near the electrodes **24A** is prevented. The operation of this embodiment is identical to that of the previous embodiments.

INDUSTRIAL APPLICABILITY

As explained above, according to the present invention, it is possible to provide a light source device having a discharge tube having a long operating life.

What is claimed is:

1. A light source device comprising:

- a discharge tube,
- a reflector to reflect a light radiated from said discharge tube,
- a support member arranged at inward from an end of said discharge tube to support said discharge tube at a prescribed position with respect to said reflector to support said discharge tube to said reflector, and
- a heat conduction member contacting a center portion of said discharge tube in a longitudinal direction.

2. A light source device as set forth in claim 1, wherein said support member contacts said discharge tube at position inward from an end of said discharge tube, said position except for a region to which metal particles from an electrode of said discharge tube are attached.

3. A light source device as set forth in claim 1, wherein said heat conduction member contacts a center portion of said discharge tube in a longitudinal direction thereof so that a portion of said discharge tube near an electrode of said discharge tube is prevented from being the lowest point in temperature.

4. A light source device as set forth in claim 1, wherein said heat conduction member contacts a center portion of said discharge tube in a longitudinal direction thereof, so that the center portion of said discharge tube being the lowest point in temperature.

5. A light source device as set forth in claim 1, wherein said heat conduction member is positioned at the center portion of said discharge tube in a longitudinal direction thereof and is in contact with to fasten said discharge tube at least two positions thereof.

9

6. A light source device as set forth in claim 1, wherein said heat conduction member is in contact with said reflector.

7. A light source device as set forth in claim 1, wherein said support member is made of heat conductive material.

8. A light source device as set forth in claim 1, wherein said light source device further comprises a heat radiating unit for cooling said heat conduction member.

9. A light source device as set forth in claim 8, wherein said light source device further comprises a heat irradiating fan for cooling said heat conduction member.

10. A light source device as set forth in claim 1, wherein said discharge tube is sealed with mercury.

11. A light source device as set forth in claim 1, wherein said metal particles is sputtered within said discharge tube.

12. A light source device as set forth in claim 1, wherein said discharge tube is covered with said reflector.

10

13. A light source device as set forth in claim 1, wherein an inner surface of said support member contacts with said discharge tube.

14. A light source device as set forth in claim 1, wherein an outer surface of said support member contacts with said reflector.

15. A display module including a light source device, said display unit comprising the light source device as set forth in claim 1.

16. A display device mounting a light source for displaying, said display device comprising the light source device as set forth in claim 1.

17. An information handling apparatus comprising a display module including the light source device as set forth in claim 1.

18. A portable information handling apparatus comprising a display module including the light source device as set forth in claim 1.

* * * * *