



US007278696B2

(12) **United States Patent**
Matsuzaki et al.

(10) **Patent No.:** **US 7,278,696 B2**
(45) **Date of Patent:** ***Oct. 9, 2007**

(54) **INKJET RECORDING APPARATUS**

(75) Inventors: **Tetsuya Matsuzaki**, Fukuoka (JP);
Shinichi Kitamura, Fukuoka (JP);
Hiroyuki Matsuba, Fukuoka (JP);
Kensei Otsubo, Fukuoka (JP)

(73) Assignee: **Matsushita Electric Industrial Co., Ltd.**, Osaka (JP)

(*) Notice: Subject to any disclaimer, the term of this patent is extended or adjusted under 35 U.S.C. 154(b) by 0 days.

This patent is subject to a terminal disclaimer.

(21) Appl. No.: **11/368,485**

(22) Filed: **Mar. 7, 2006**

(65) **Prior Publication Data**

US 2006/0146104 A1 Jul. 6, 2006

Related U.S. Application Data

(62) Division of application No. 11/087,751, filed on Mar. 24, 2005, now Pat. No. 7,059,712, which is a division of application No. 10/387,558, filed on Mar. 14, 2003, now Pat. No. 6,929,358, which is a division of application No. 09/811,631, filed on Mar. 20, 2001, now Pat. No. 6,582,067.

(30) **Foreign Application Priority Data**

Mar. 21, 2000 (JP) 2000-77434
Mar. 22, 2000 (JP) 2000-80461
Mar. 24, 2000 (JP) 2000-84867

(51) **Int. Cl.**

B41J 3/00 (2006.01)
B41J 2/01 (2006.01)

(52) **U.S. Cl.** 347/4; 347/104

(58) **Field of Classification Search** 347/3, 347/4, 5, 85, 104, 153, 215, 217, 218
See application file for complete search history.

(56) **References Cited**

U.S. PATENT DOCUMENTS

4,412,225 A * 10/1983 Yoshida et al. 347/43
4,506,277 A 3/1985 Terasawa
4,528,576 A 7/1985 Koumura et al.
4,533,928 A * 8/1985 Sugiura et al. 347/3
4,860,026 A * 8/1989 Matsumoto et al. 347/15
4,908,638 A 3/1990 Albosta et al.
4,933,727 A * 6/1990 Mizuma et al. 399/298

(Continued)

FOREIGN PATENT DOCUMENTS

JP 57-210879 12/1982

Primary Examiner—Anh T. N. Vo

(74) *Attorney, Agent, or Firm*—Wenderoth, Lind & Ponack, L.P.P.

(57) **ABSTRACT**

An inkjet recording apparatus ejects ink from recording heads to a recording paper, thereby attaching the ink to the medium for recording. The apparatus includes a carriage driving motor, a transfer motor, a scanner which reciprocates a carriage having the recording heads in a scanning direction, and a transfer machine. The transfer machine transfers the recording paper in a transfer direction perpendicular to the scanning direction. Both of the motors are located at approximately the same place in an ejecting direction of ink from the heads to the paper, and at the same height of a transfer path of the paper or on the carriage side with respect to the transfer path.

9 Claims, 17 Drawing Sheets

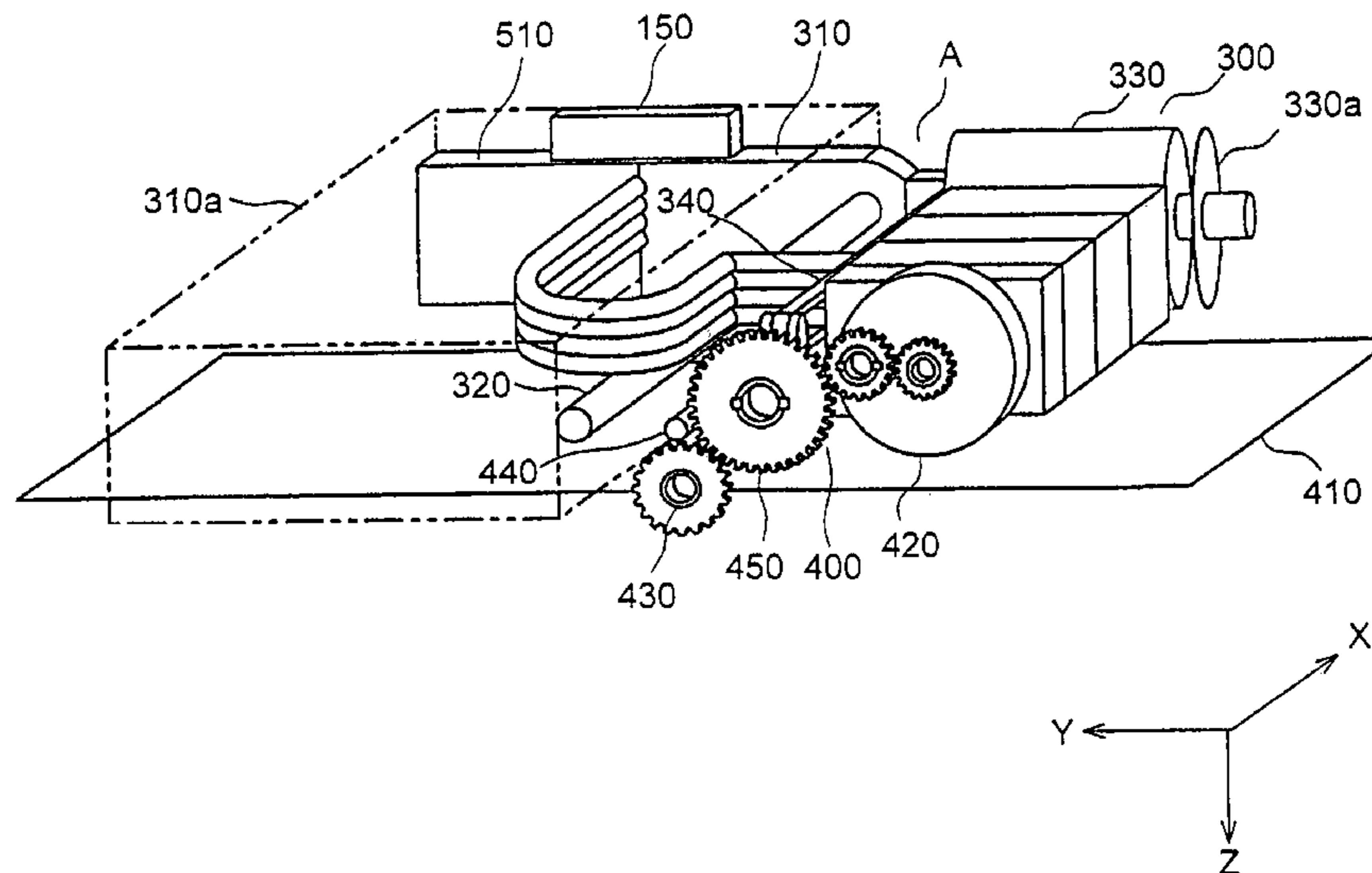

US 7,278,696 B2

Page 2

U.S. PATENT DOCUMENTS

| | | | | | | | |
|---------------|---------|----------------------|------------|----------------|---------|-----------------------|--------|
| 4,999,651 A * | 3/1991 | Duffield et al. | 347/3 | 6,142,597 A | 11/2000 | Kogami | |
| 5,619,237 A | 4/1997 | Inoue et al. | | 6,158,841 A * | 12/2000 | Kakutani | 347/40 |
| 5,971,392 A * | 10/1999 | Lee | 271/265.02 | 6,582,067 B2 * | 6/2003 | Matsuzaki et al. | 347/85 |
| 6,033,064 A | 3/2000 | Pawlowski et al. | | 6,929,358 B2 * | 8/2005 | Matsuzaki et al. | 347/85 |
| 6,091,514 A * | 7/2000 | Hasegawa et al. | 358/296 | | | | |

* cited by examiner

FIG. 1

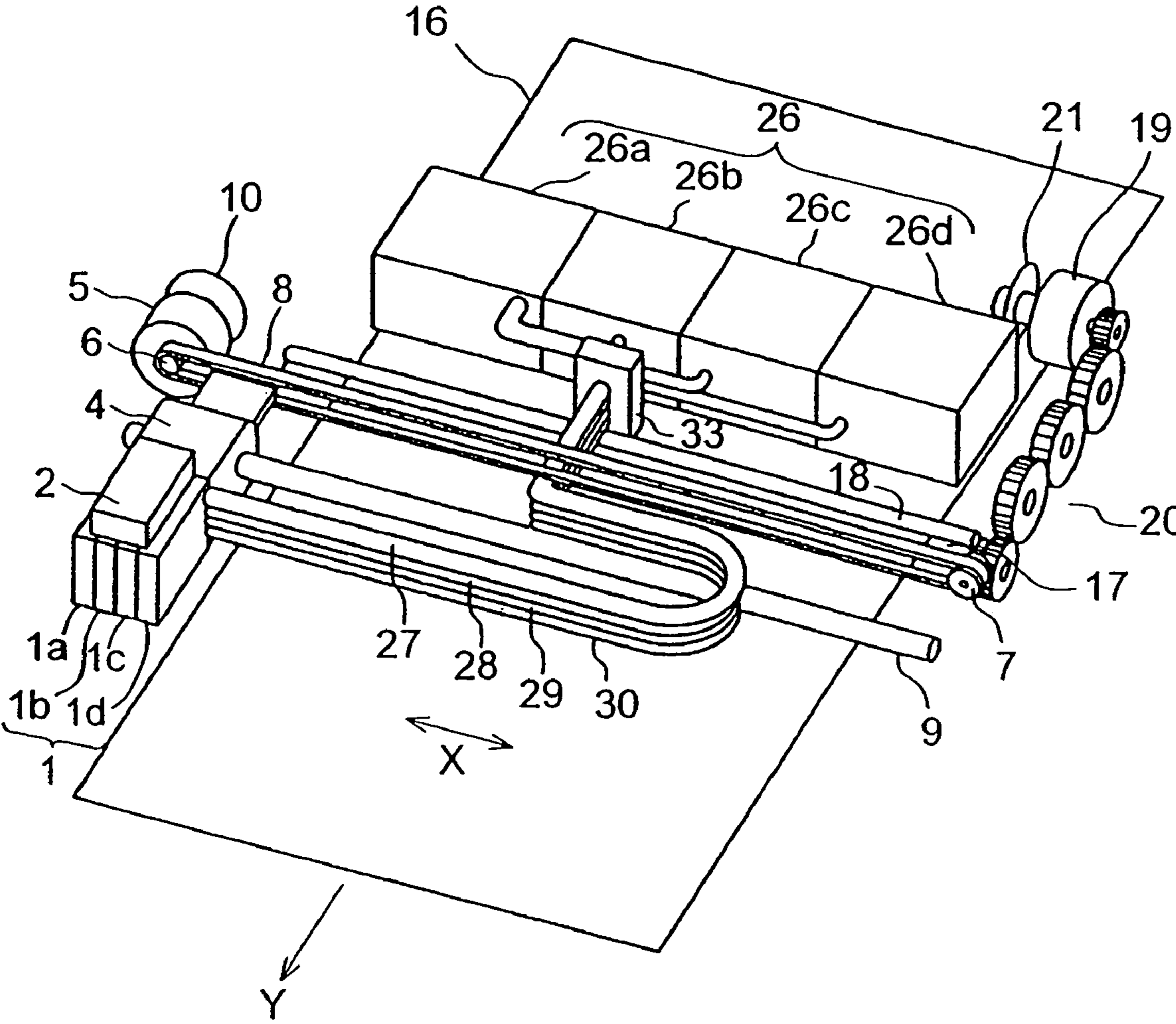

FIG. 2

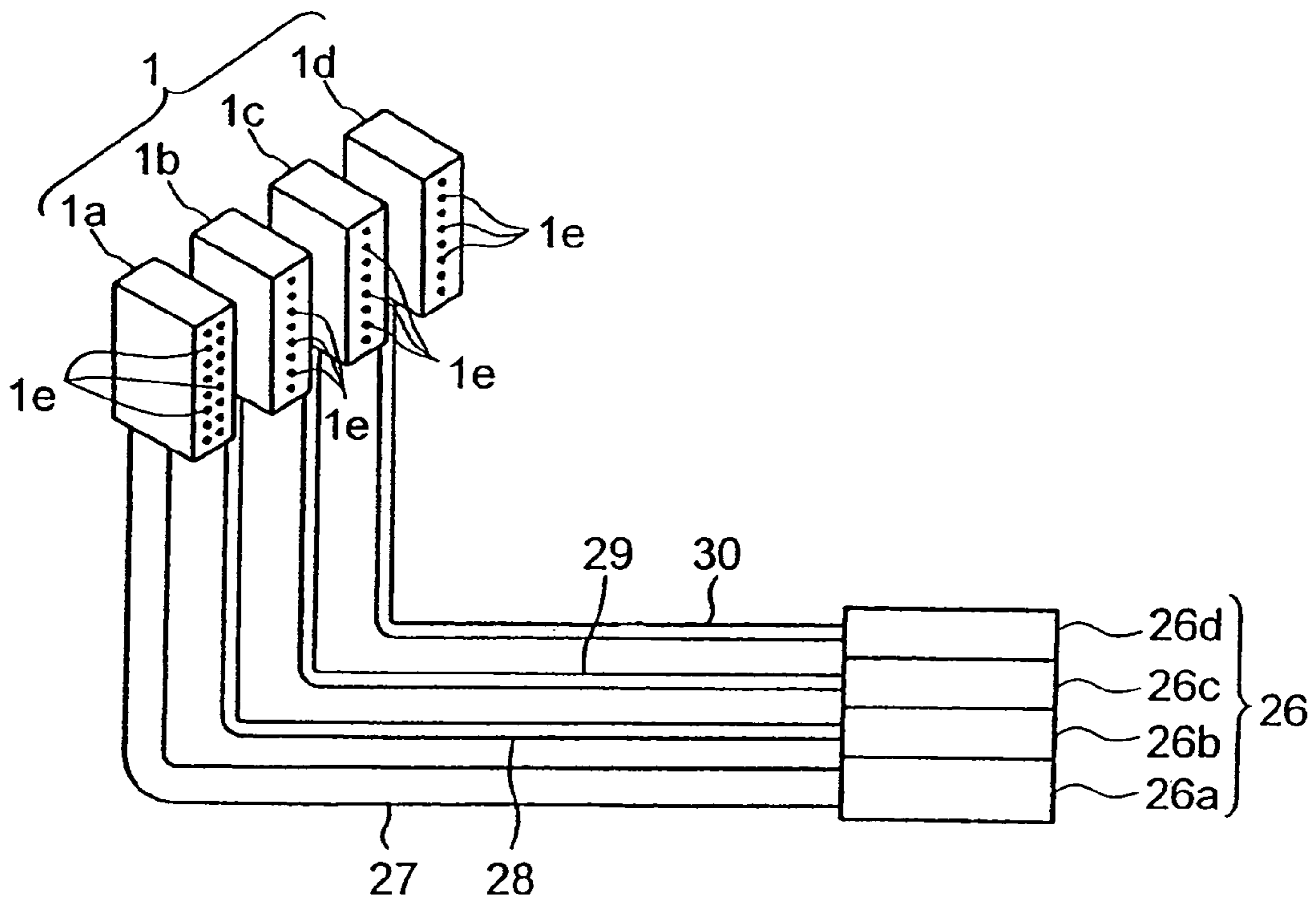

FIG. 3

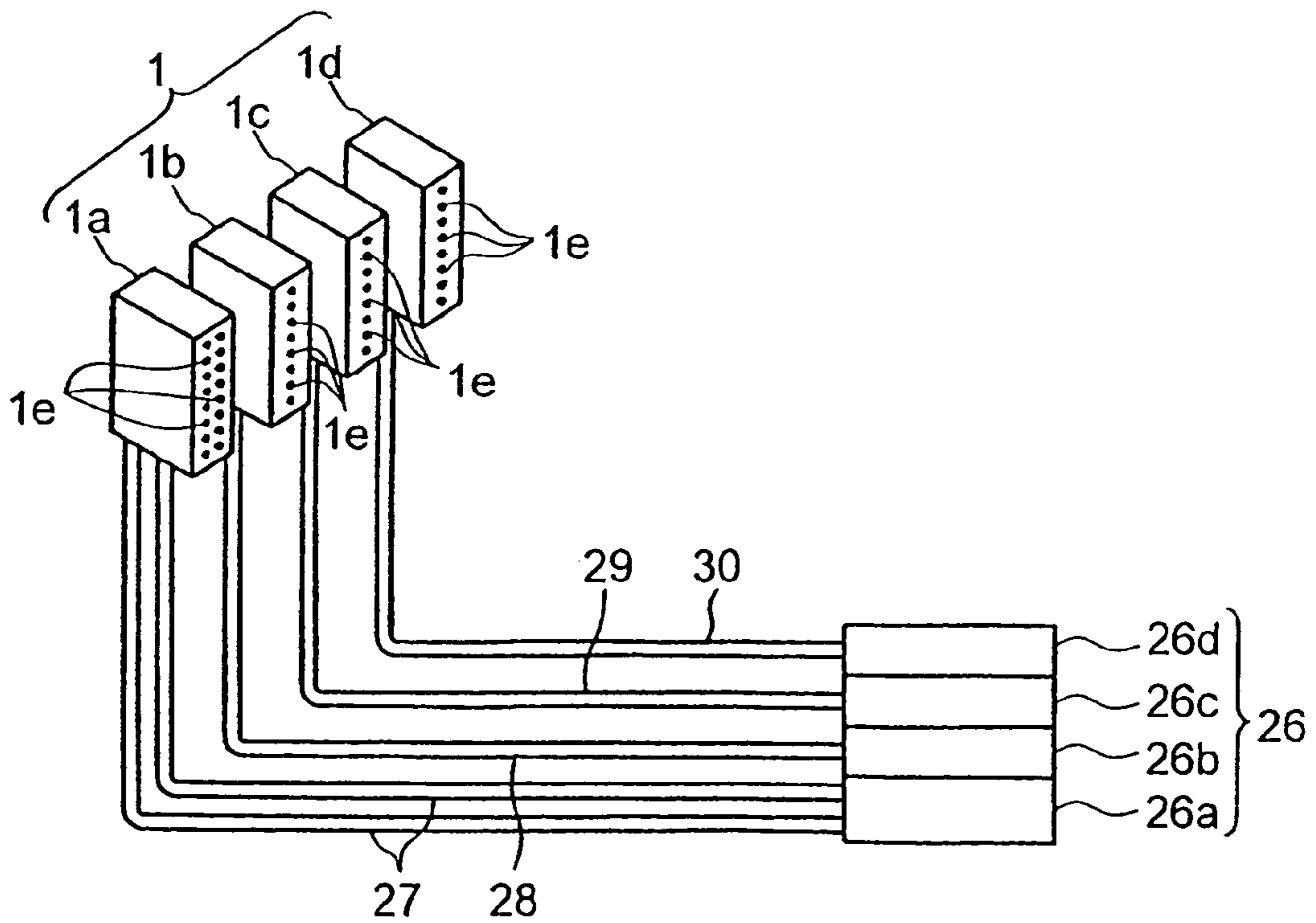

FIG. 4

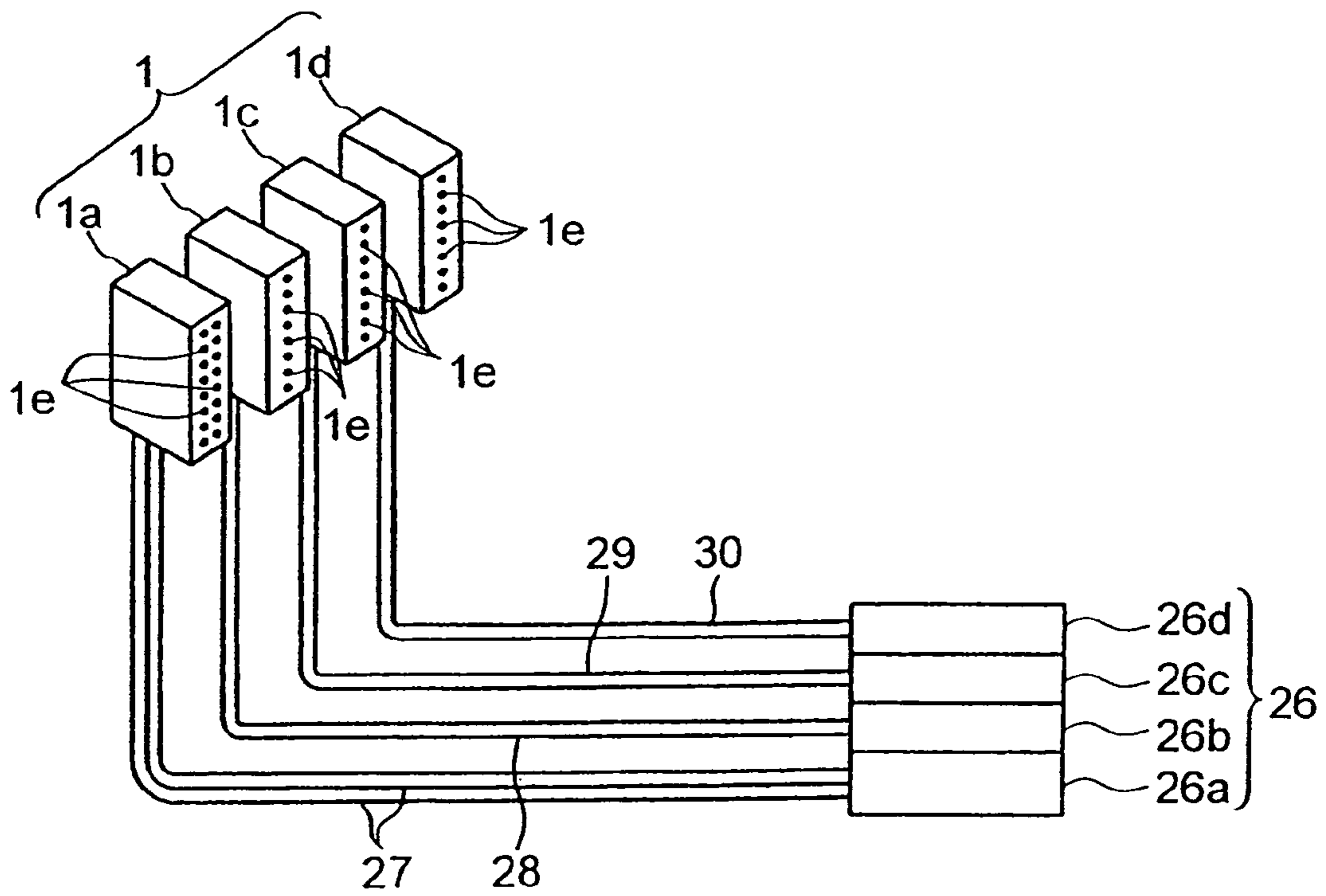

FIG. 5

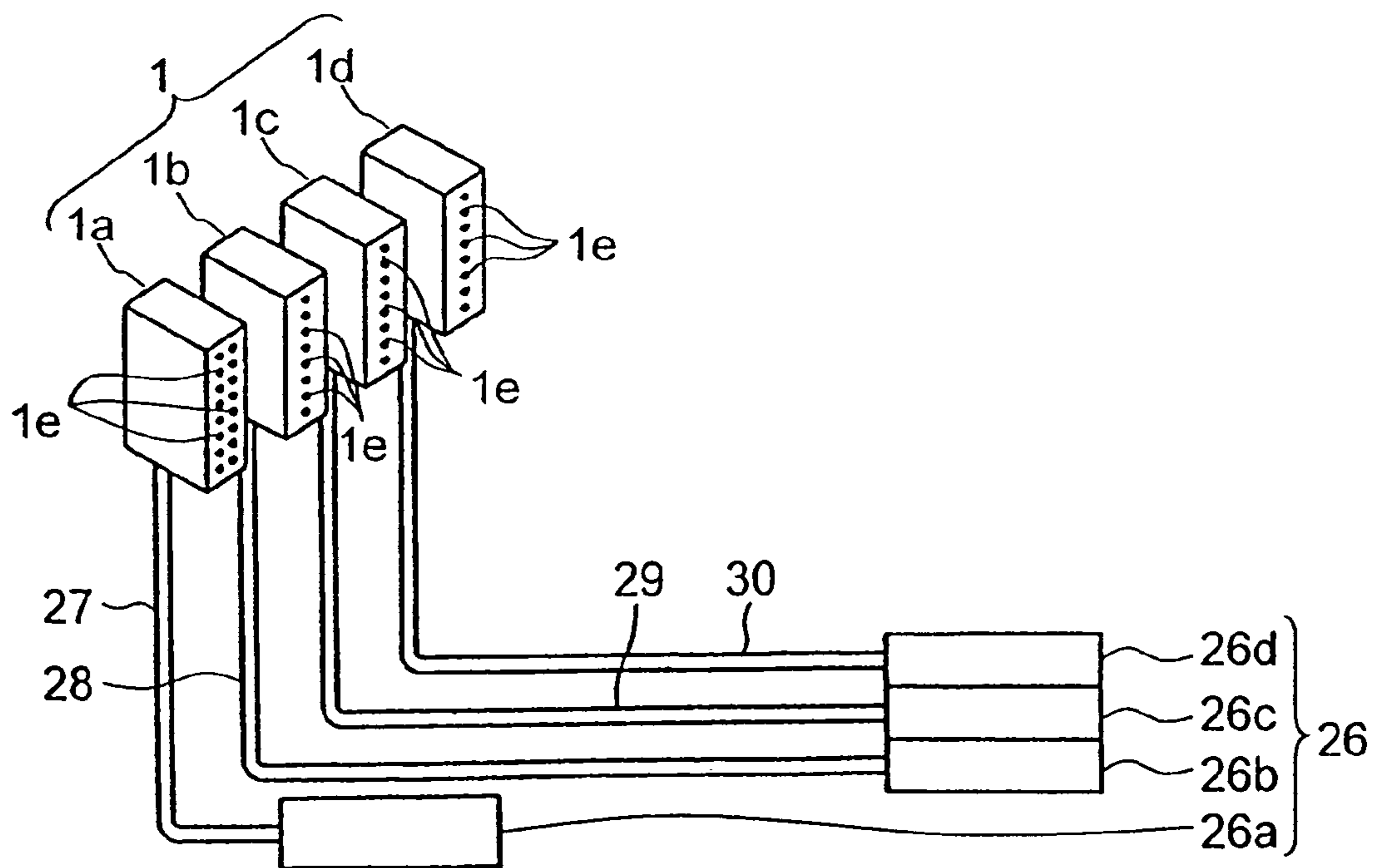

FIG. 6

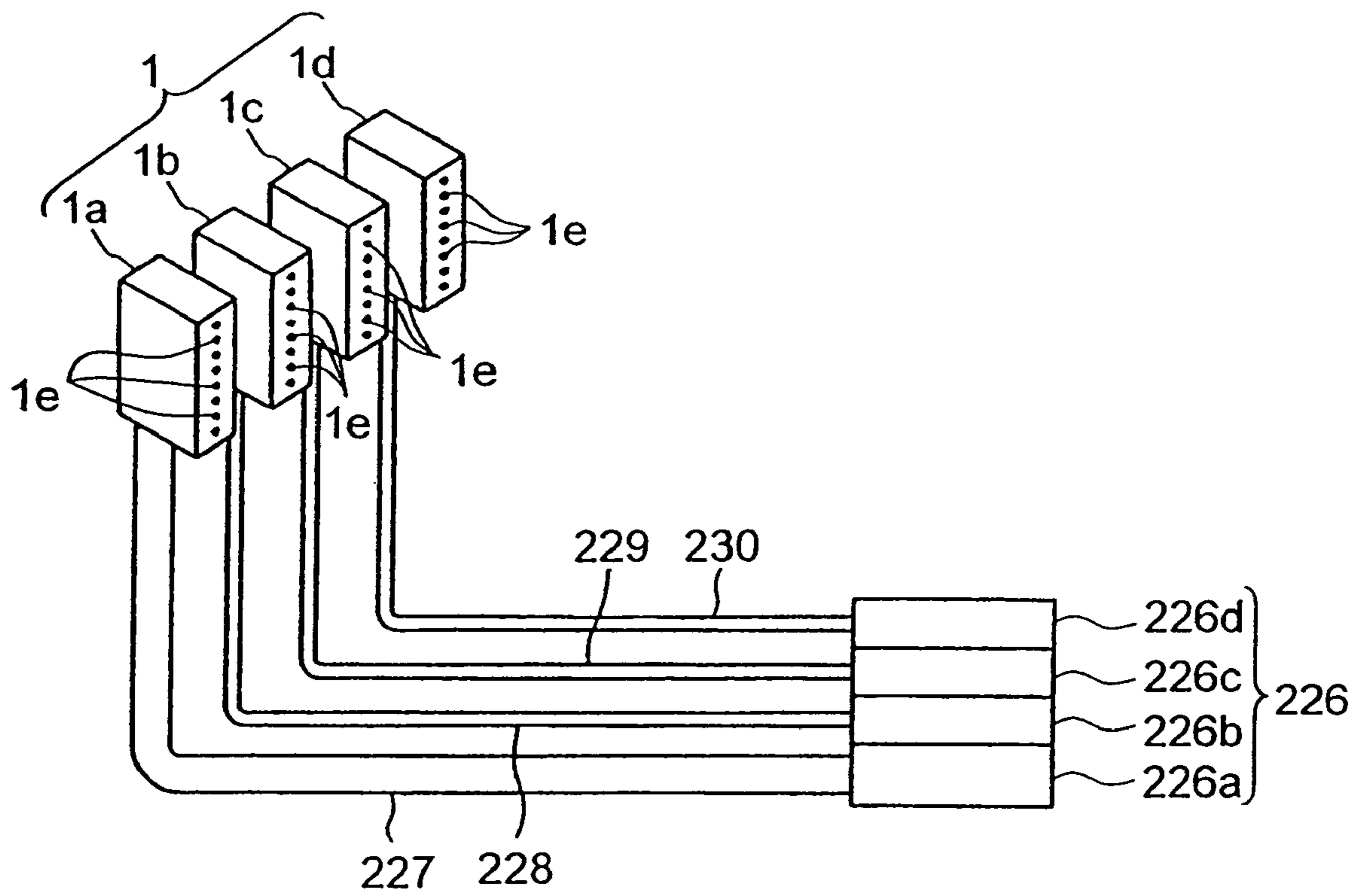

FIG. 7

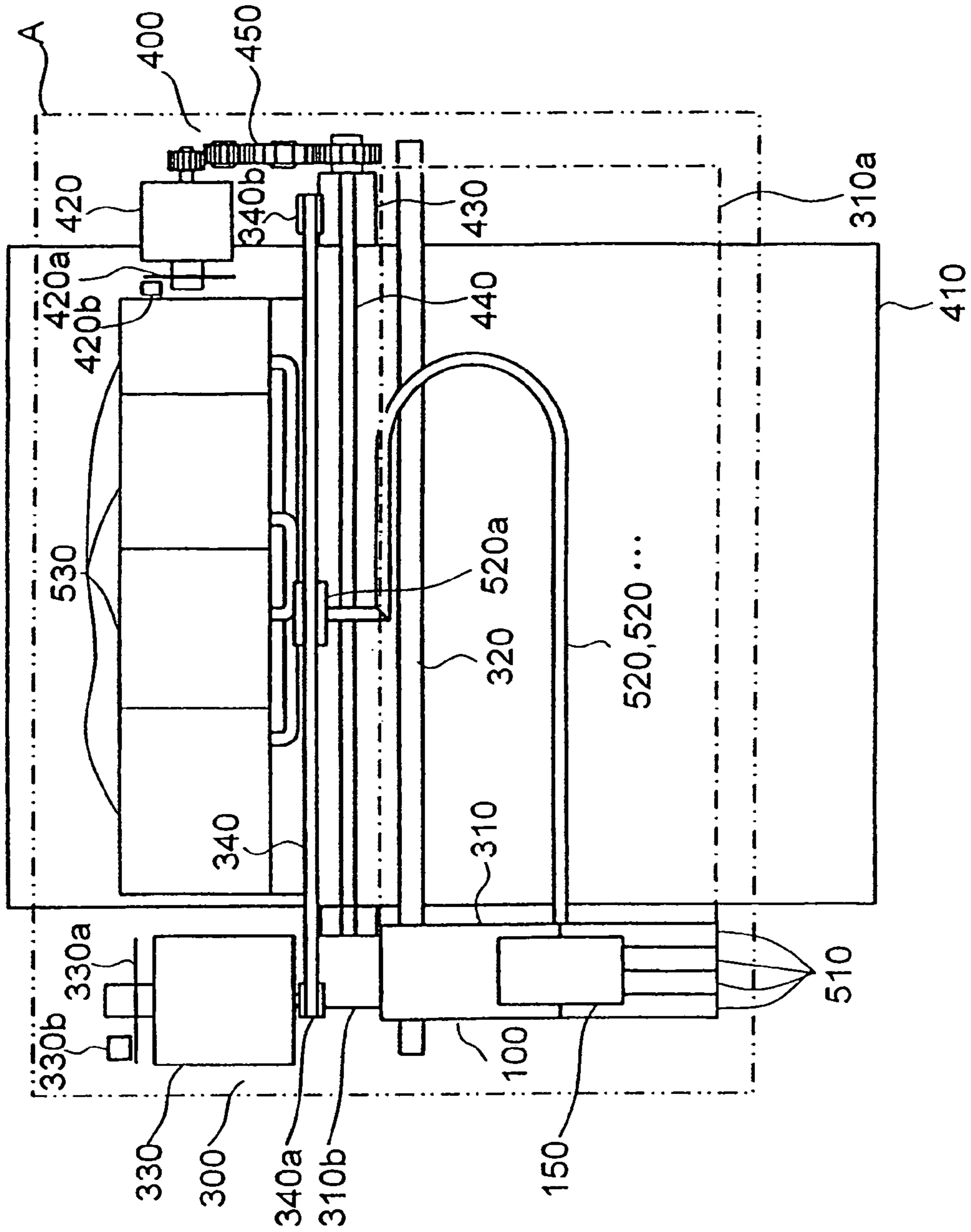

FIG. 8

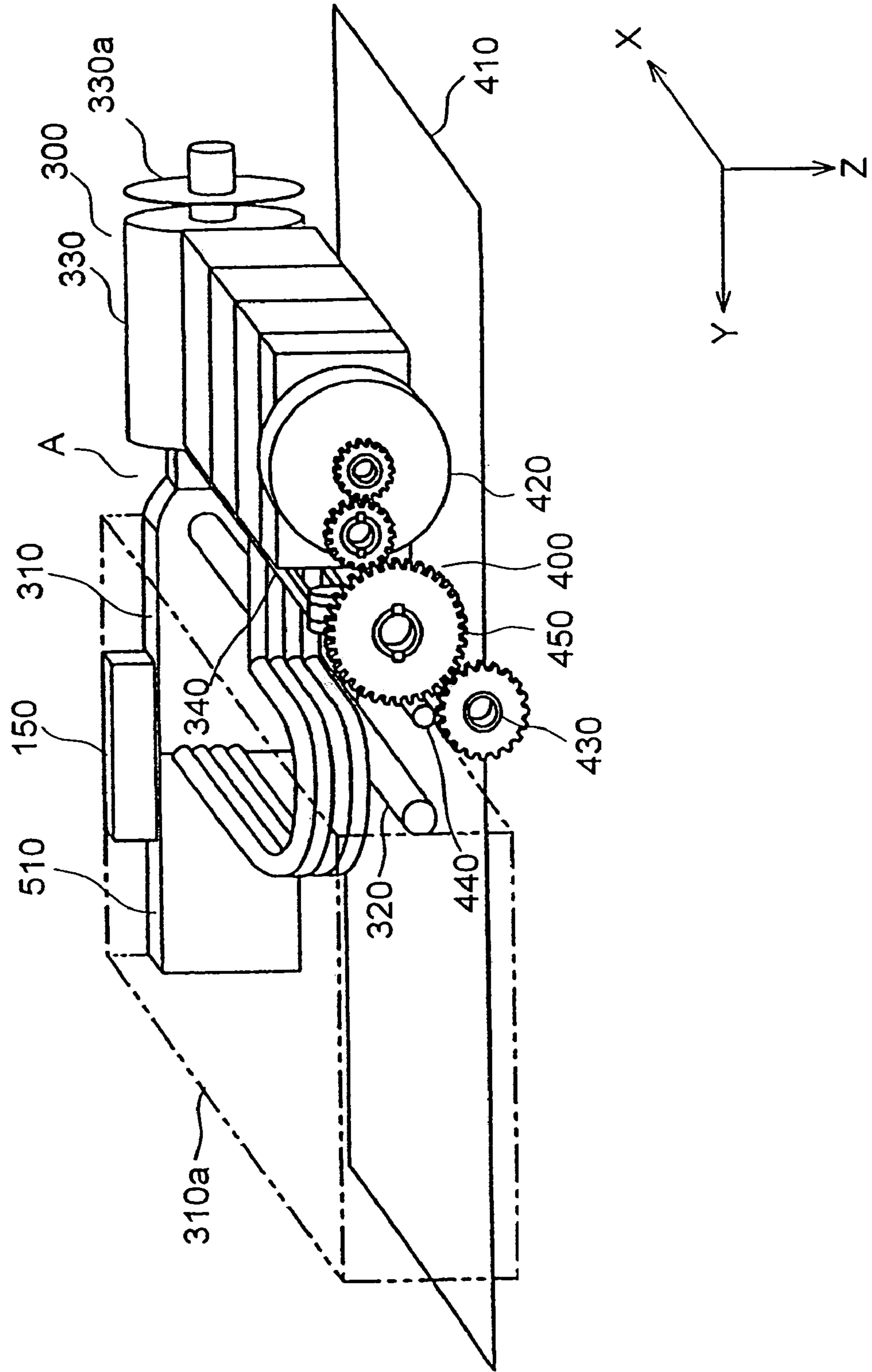

FIG. 9

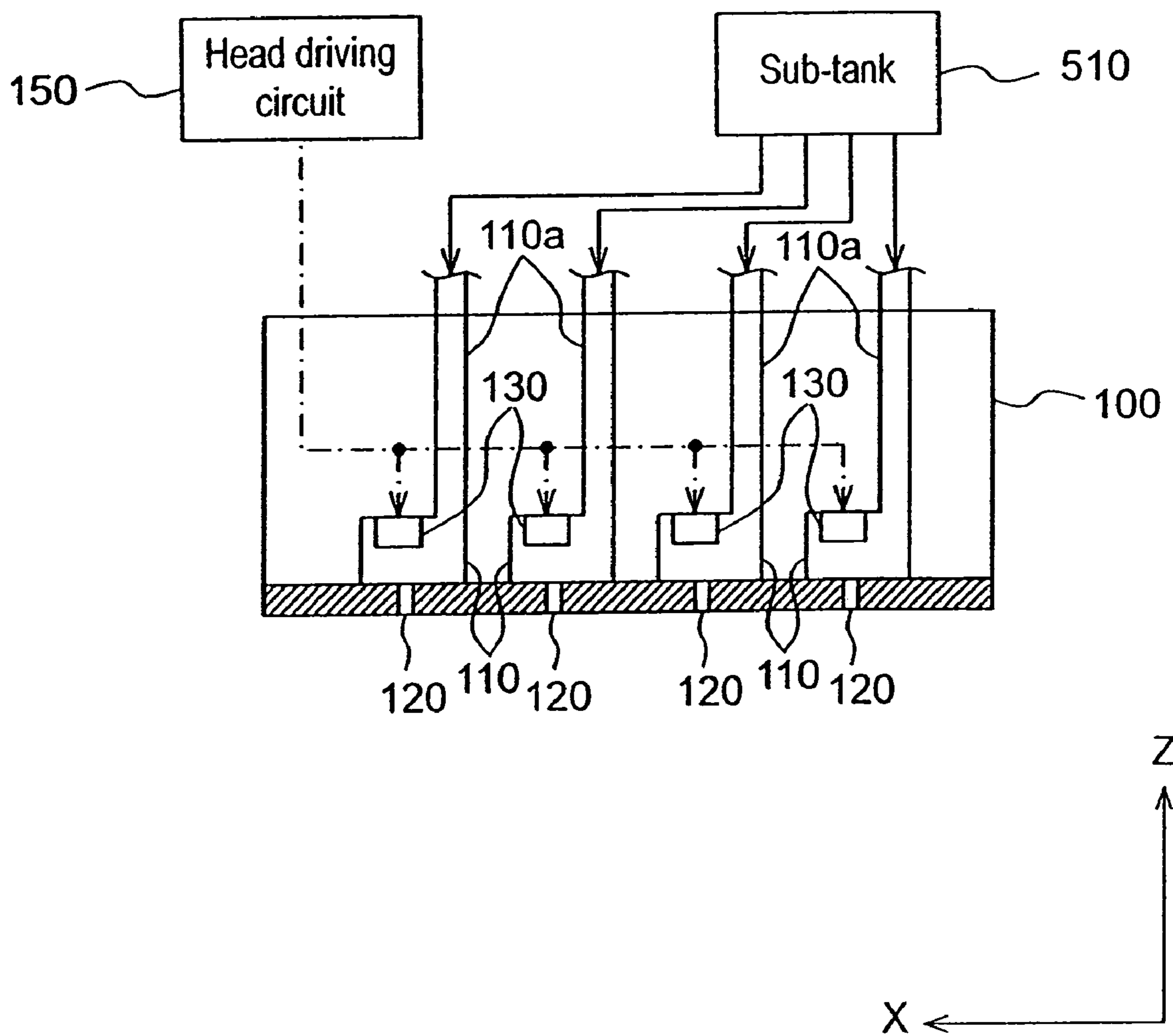

FIG. 10

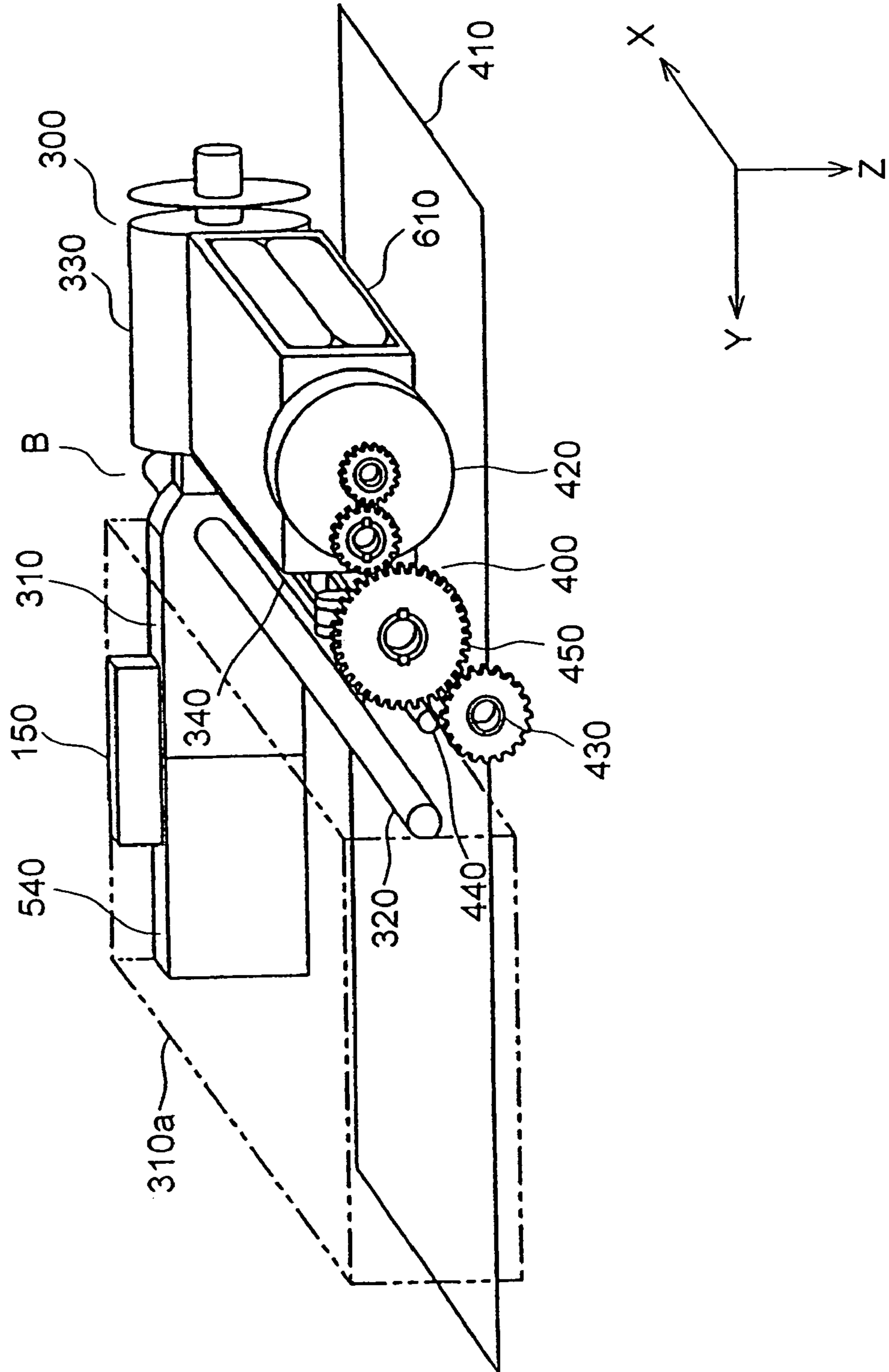

FIG. 11

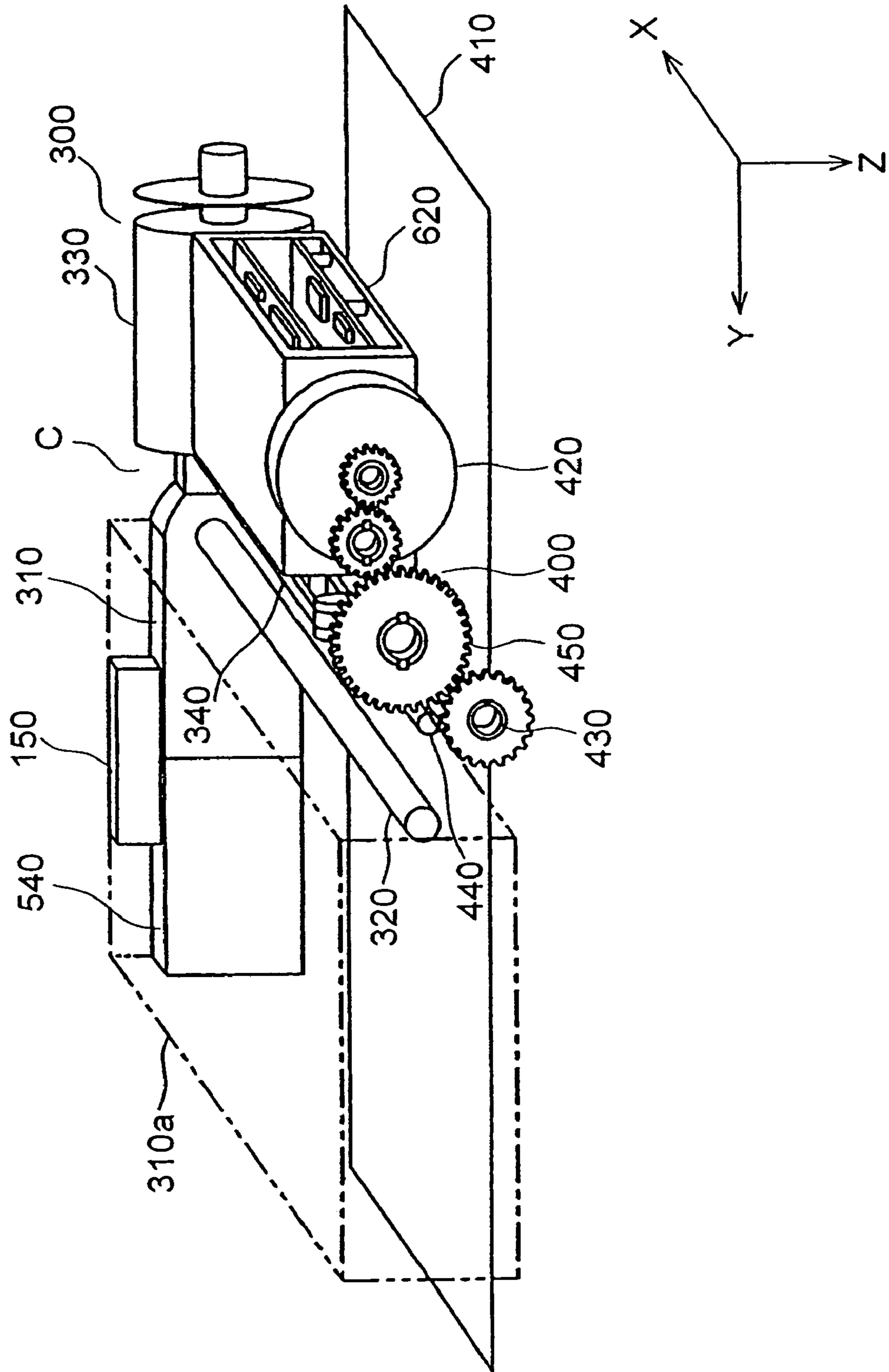

FIG. 12

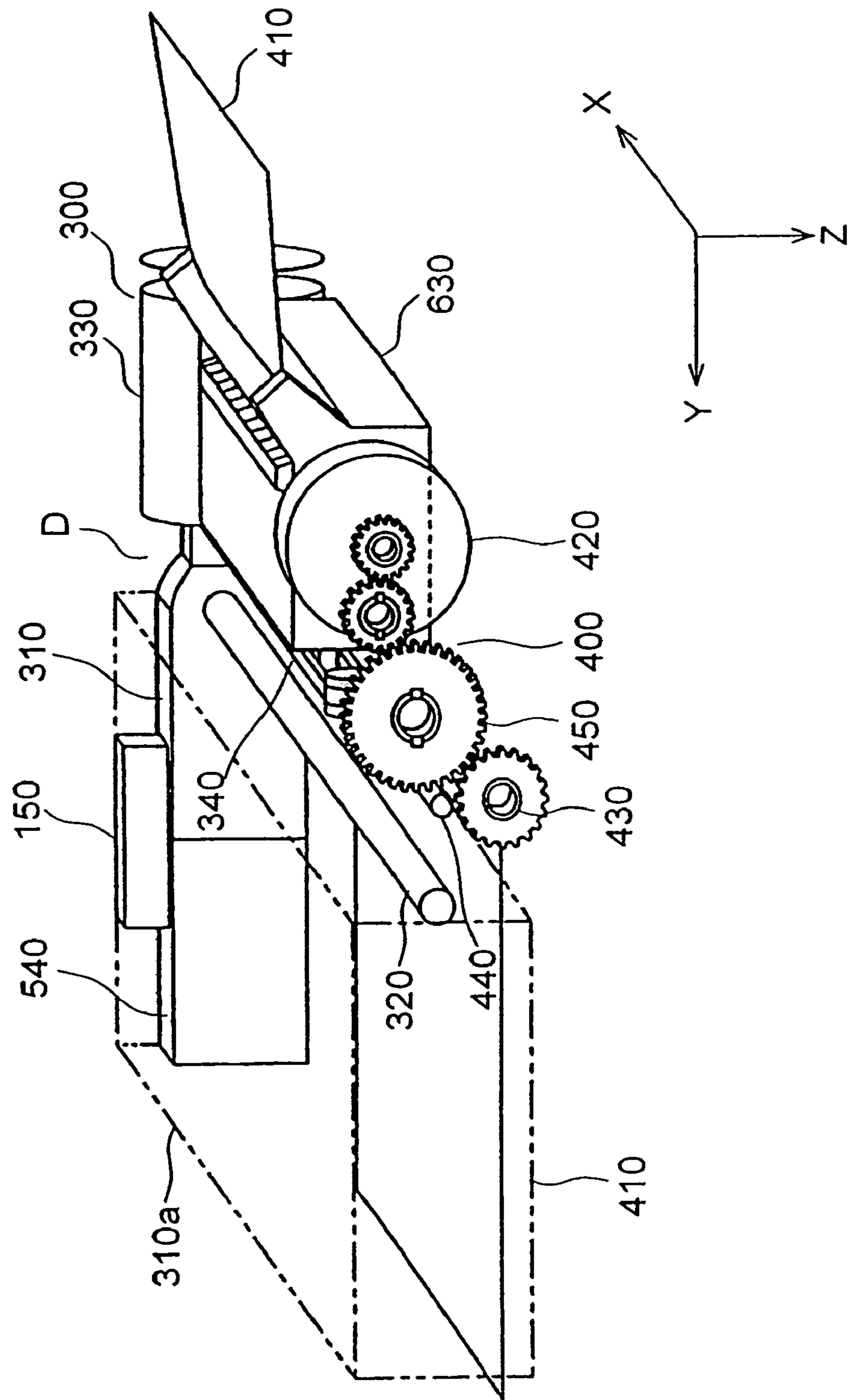

FIG. 13

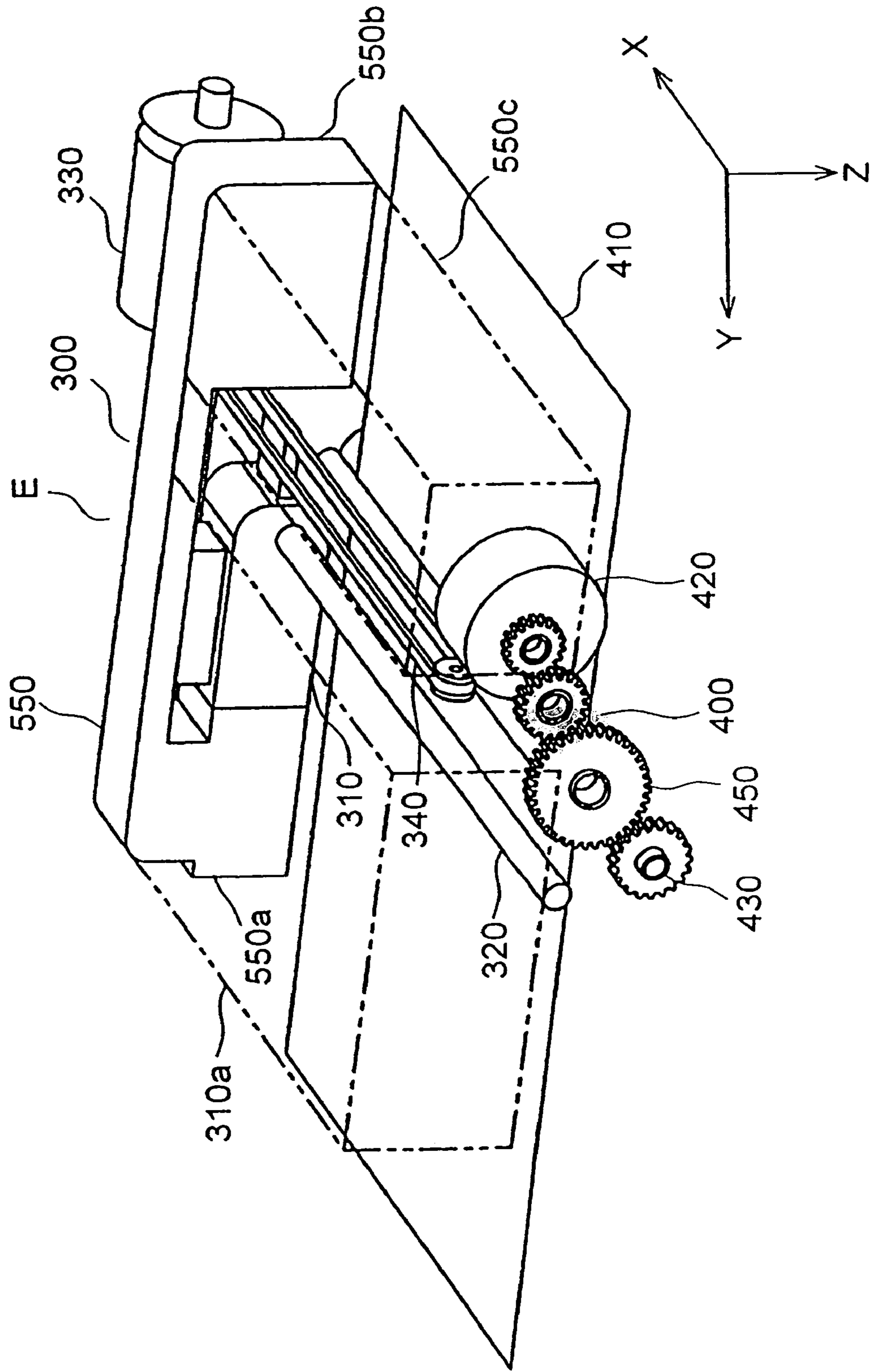

FIG. 14

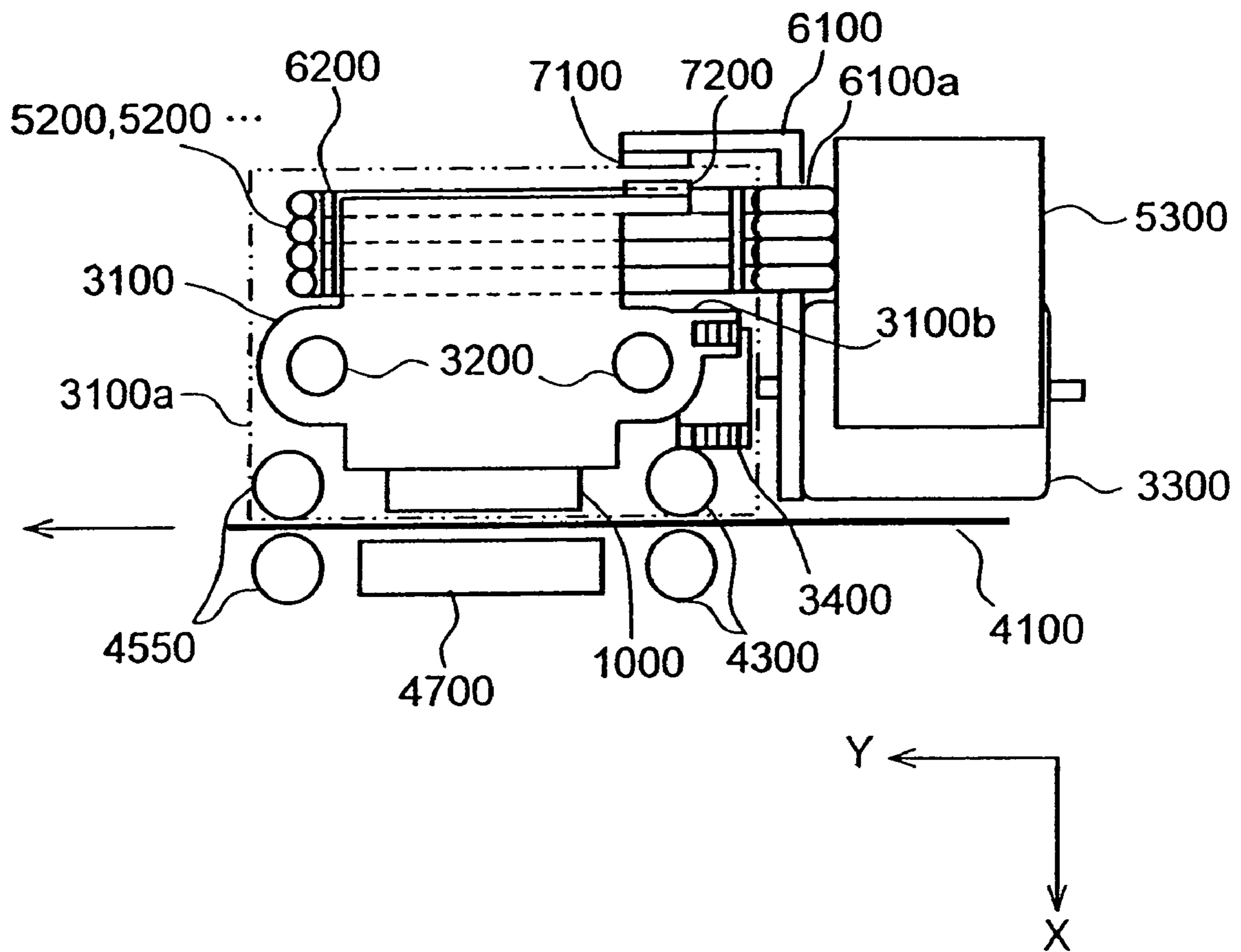

FIG. 15

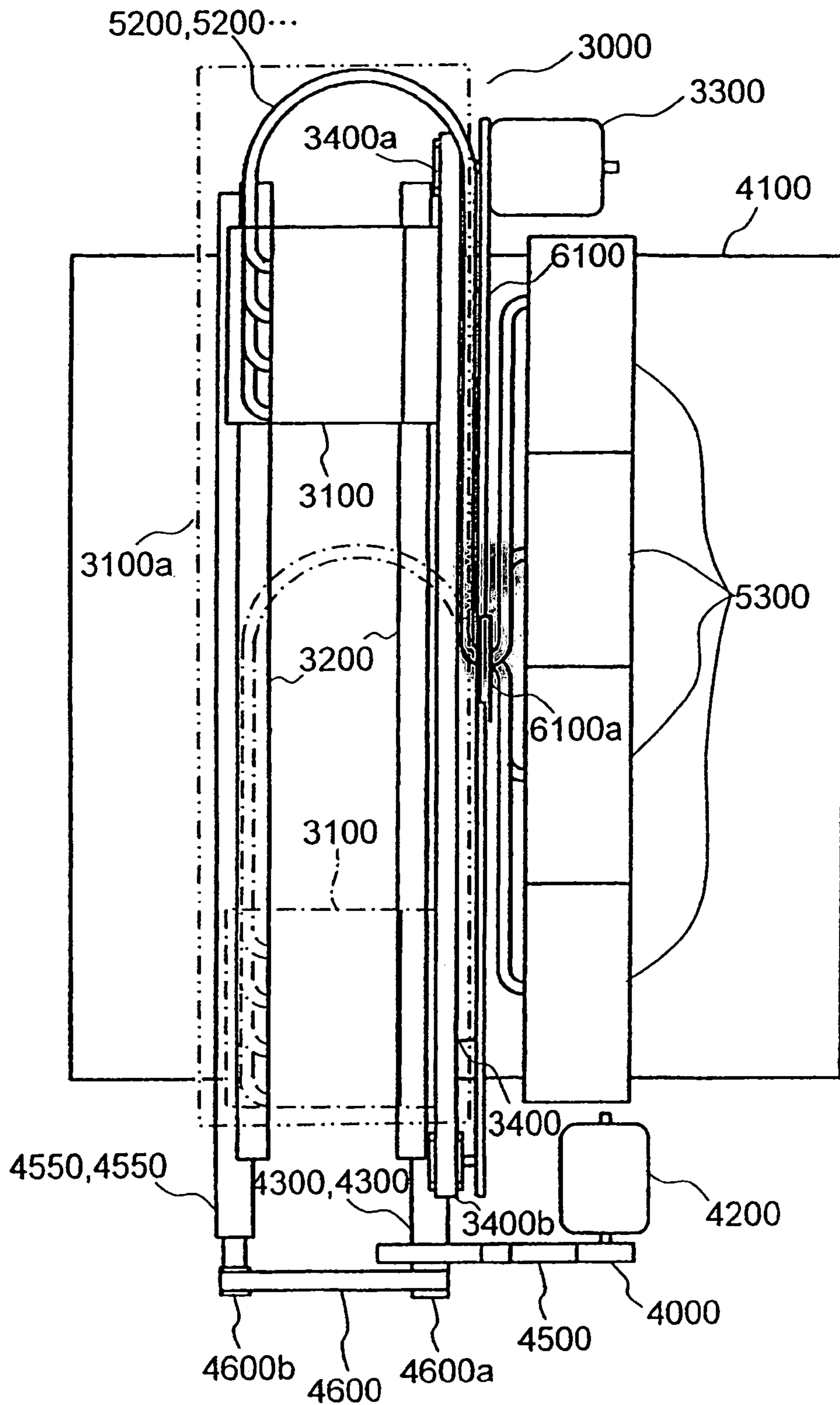

FIG. 16

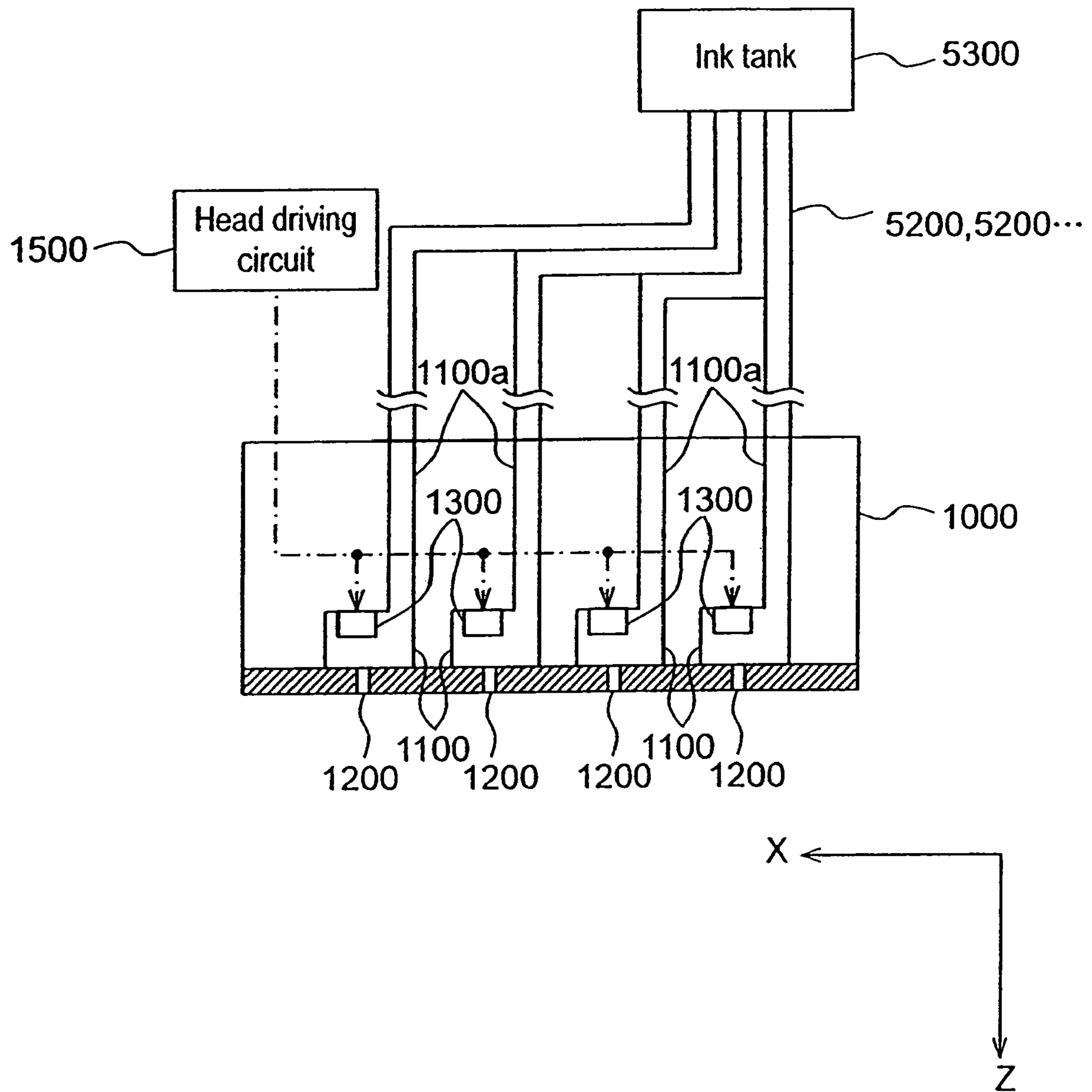

FIG. 17

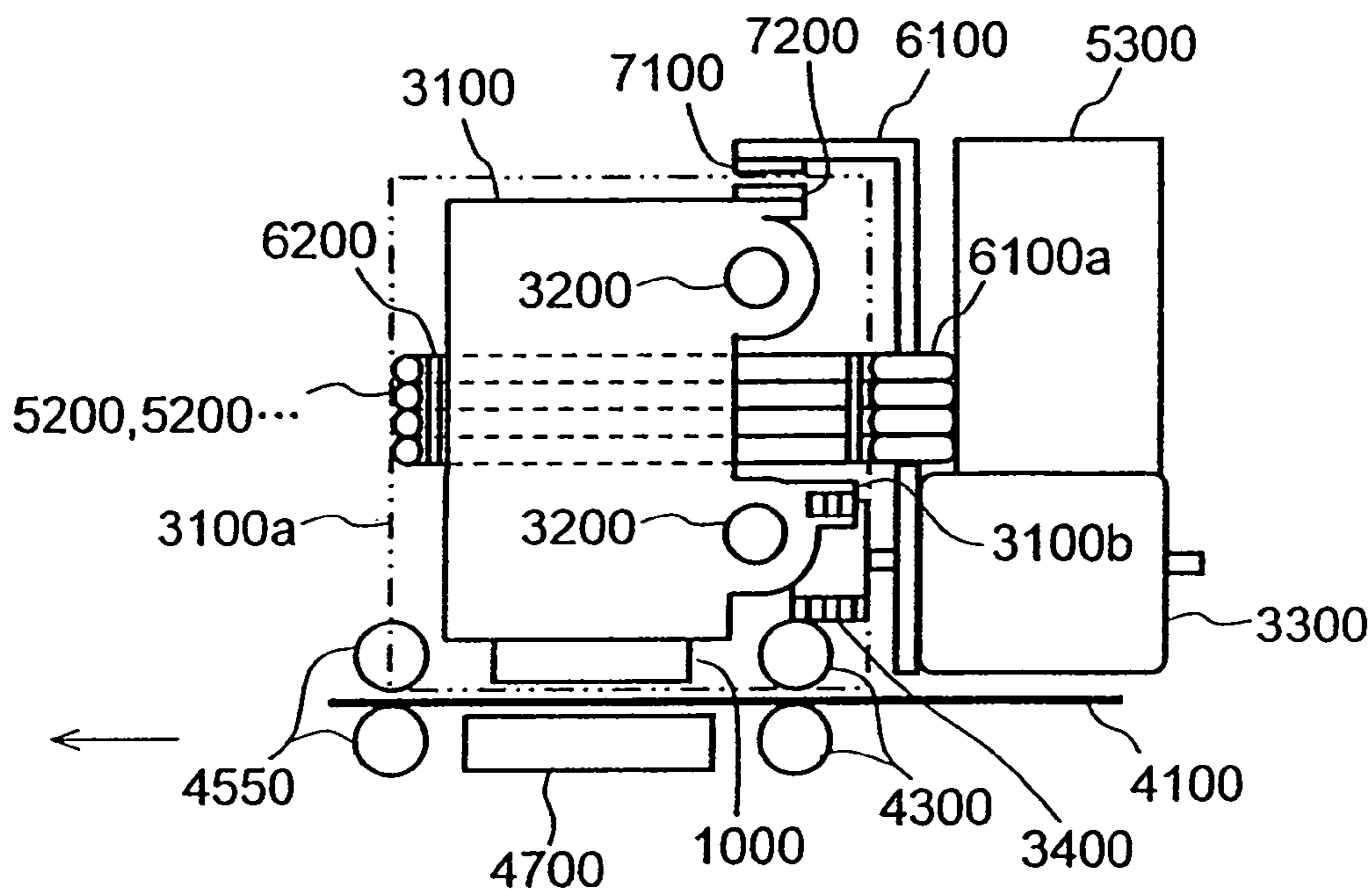

FIG. 18

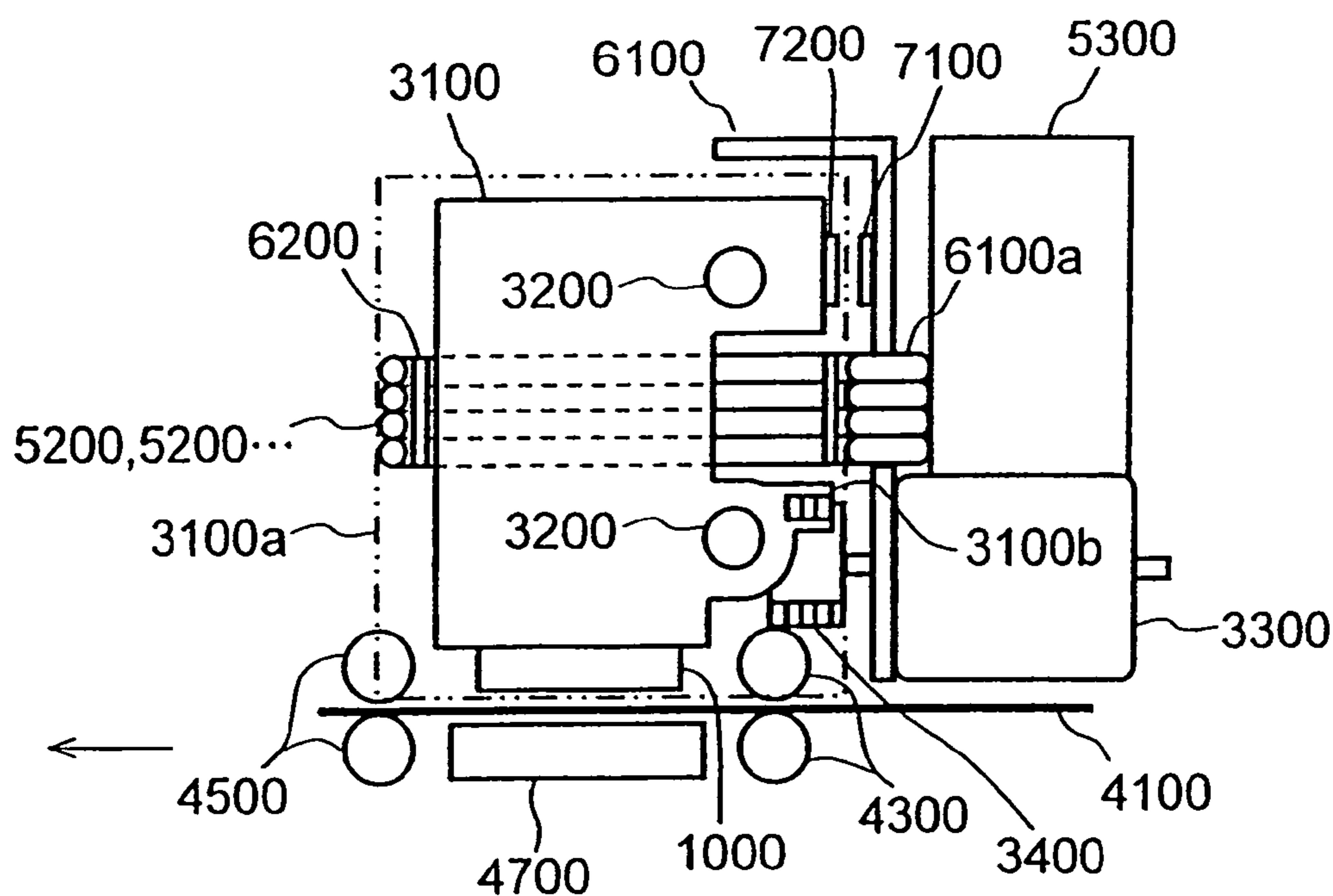

FIG. 19

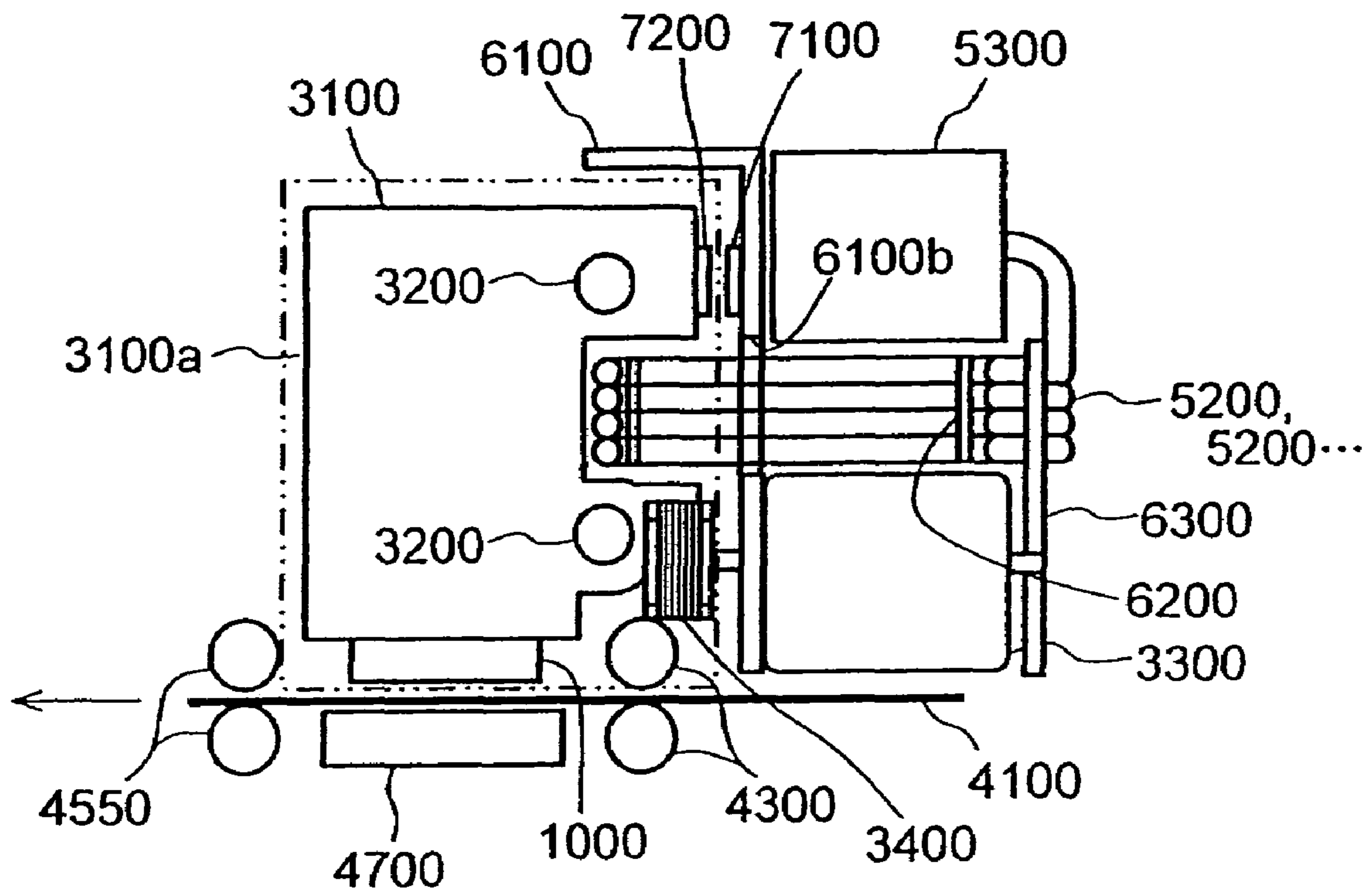
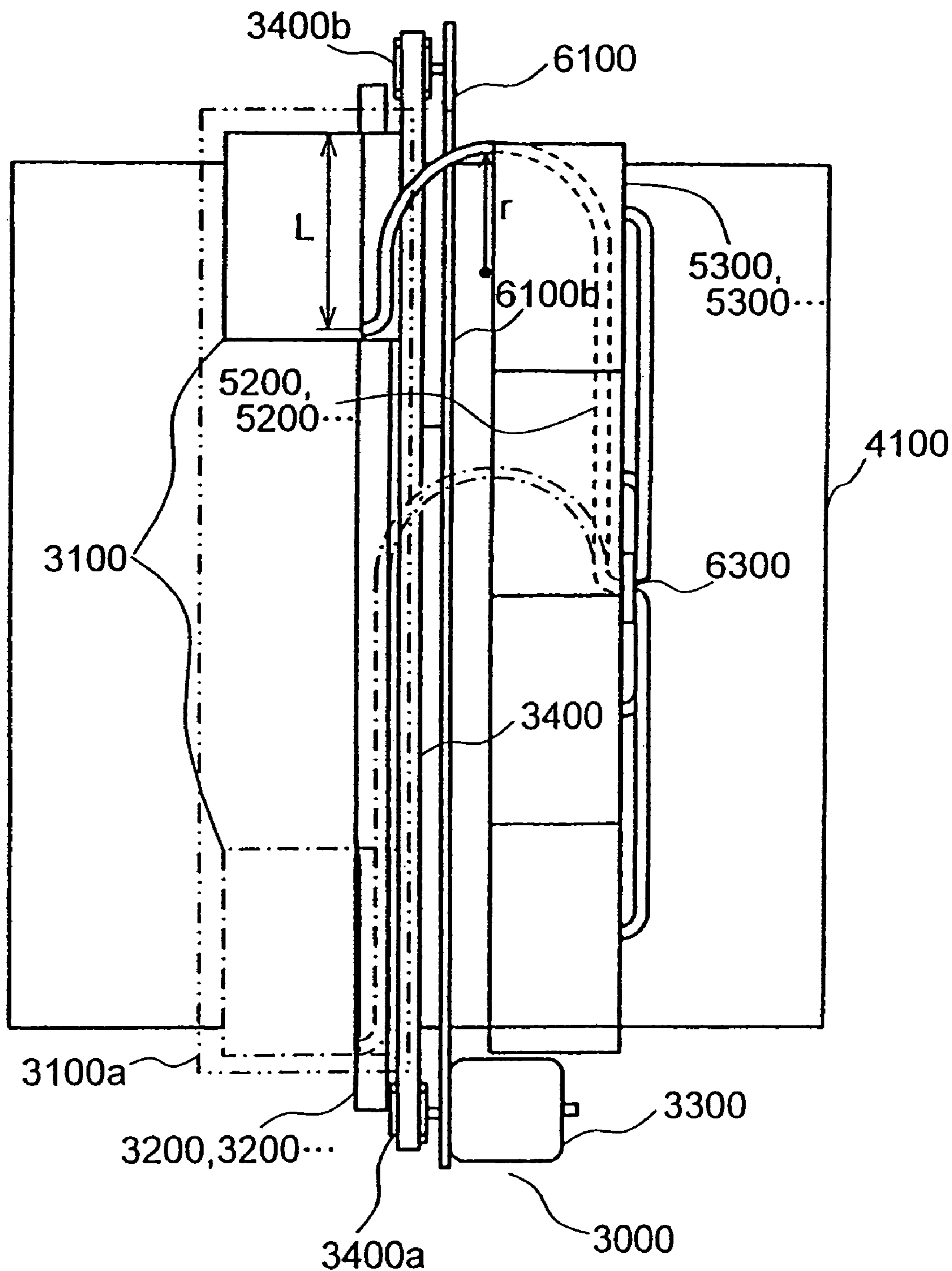

FIG. 20



INKJET RECORDING APPARATUS

This application is a divisional application of application Ser. No. 11/087,751, filed Mar. 24, 2005, now U.S. Pat. No. 7,059,712 which is a divisional application of application Ser. No. 10/387,558, filed Mar. 14, 2003, now U.S. Pat. No. 6,929,358, which is a divisional application of application Ser. No. 09/811,631, filed Mar. 20, 2001, now U.S. Pat. No. 6,582,067.

FIELD OF THE INVENTION

The present invention relates to an inkjet recording apparatus which ejects ink from a recording head to a recording medium and attaches the ink onto the medium, thereby performing the recording.

BACKGROUND OF THE INVENTION

Conventionally, an inkjet recording apparatus, which ejects ink from a recording head to a recording medium and attaches the ink onto the medium, thereby performing the recording, has been known in the market.

In this conventional apparatus, a carriage to which the recording head is mounted reciprocates in a scanning direction, while the recording medium, such as a sheet of paper, is transferred in a direction perpendicular to the scanning direction. Positions of the recording head and the recording paper, as well as the ejection of the ink from the head, are controlled, so that the ink is attached to a specified position on the recording paper for recording. In this apparatus, a carriage driving motor, as a driver, reciprocates the carriage in the scanning direction, while a transfer motor, as a driver, transfers the recording paper in a transfer direction.

High speed recording is demanded for the inkjet recording apparatus, while downsizing the apparatus is also required. For realizing the high speed recording, the carriage and the recording paper must move at high speed. For instance, it is desirable to employ a high-power carriage driving motor and a high-power transferring motor. However, the high-power motor needs a larger outer diameter or a longer length along a rotating axis, so that a size of the motor is necessarily be bulky.

On the other hand, on a transfer path of the recording paper or in a travel space where the carriage reciprocates, no components should be placed. Thus, these motors must be placed outside of the transfer path and travel space, and a large additional space must be provided for disposing these motors. As a result, high-speed recording is achieved at the cost of increasing the size of the apparatus.

As such, the inkjet recording apparatus has encountered contradictory requirements, i.e., high-speed recording and downsizing.

In order to solve the problem of these contradictory requirements, the following structure is designed. The carriage and an ink-tank are coupled to each other with ink supplying tubes, and the ink-tank is disposed outside of the carriage. Ink in the ink-tank is supplied to recording heads of the carriage via the tubes. However, even for an apparatus with this structure, it is very difficult to dispose the tubes so that the ink can be supplied in a stable manner for recording at high-speed, e.g., ink ejecting frequency is not less than 18 kHz.

When these tubes are bent with a curvature as small as an electric wiring can be bent, the flowing path is bent and damaged. The smaller the diameter of the tube, the smaller the curvature that the tube can be bent. However, the

resistance in the flowing path against the ink increases due to narrowing the diameter of the tube.

Therefore, these tubes are desirably disposed with rather larger curvatures, which, however, requires a larger space and results in a bulky apparatus.

Even if the tubes are disposed with rather larger curvatures, the carriage is placed at a distance from the ink-tank, so that the tubes must be long. This results in greater resistance from the flow-path against the flowing ink, so that the ink cannot be supplied in a stable manner. In addition to this, the distant placing of the ink-tank from the carriage invites a bulky apparatus. Further, narrower and longer tubes yield a greater flow path resistance against the flowing ink, which prevents high-speed printing.

SUMMARY OF THE INVENTION

The present invention addresses the problem discussed above, and aims to provide an inkjet recording apparatus in which the two contradictory requirements, i.e., high-speed recording and downsizing, are compatible.

The inkjet recording apparatus of the present invention comprises recording heads mounted to a carriage and ejecting plurality of colored inks, ink tanks for pooling ink of respective colors, and a plurality of ink supplying tubes for coupling the recording heads to ink tanks so that the ink of each color in the ink tanks is supplied to the recording heads, respectively. A specific color ink is ejected in a greater amount per unit time than other colored inks, and an ink supplying tube for the specific color supplies a greater amount than other tubes assigned to other colors.

Another inkjet recording apparatus of the present invention comprises, recording heads mounted to a carriage and ejecting a plurality of colored inks, ink tanks for pooling ink of respective colors; and a plurality of ink supplying tubes for coupling the recording heads to ink tanks so that the ink of each color in the ink tanks is the recording heads, respectively. A viscosity of a specific color of ink is greater than those of other colors of ink, and the ink supplying tube for the specific color supplies equal to or greater amount than the tubes assigned to other colors.

Still another inkjet recording apparatus of the present invention comprises a scanner having a carriage-driving-motor for reciprocating a carriage having recording heads in a scanning direction (X axis direction), and a transfer machine having a transfer motor for transferring a recording paper in a transfer direction (Y axis direction) perpendicular to the scanning direction. Both of the motors are at approximately the same place regarding an ink-ejecting-direction (Z axis direction). Actually, the motors are disposed at a height of the transfer-path of the recording paper, or the motors are disposed on the carriage side with respect to the transfer path.

Still further, another inkjet recording apparatus of the present invention comprises a carriage having recording heads and reciprocating in a scanning direction, ink tanks containing ink to be supplied to the recording heads, and ink supplying tubes routed from the carriage to the ink tanks via travel space for the carriage reciprocating, thereby coupling the carriage to the ink tanks. The inks ejected from the recording heads are attached to a recording paper transferred in a transfer direction perpendicular to a scanning line, thereby performing the recording.

Still another inkjet recording apparatus of the present invention comprises recording heads for ejecting different colored ink independently, a carriage having the recording heads and reciprocating in a scanning direction (X axis

3

direction), a plurality of ink tanks aligned in the scanning direction and containing respective colors of ink to be supplied to the recording heads, ink supplying tubes routed from the carriage to the ink tanks via travel space for the carriage reciprocating, thereby coupling the carriage to the ink tanks, and a coupling section disposed on the ink tank side of the carriage travel space and bundling the ink supplying tubes. Among the plurality of ink tanks, the ink tank containing the ink of the highest viscosity is placed closest to the coupling section. The ink ejected from the recording heads is attached to a recording paper transferred in a transfer direction (Y axis direction) perpendicular to the scanning direction thereby performing the recording.

Still another inkjet recording apparatus of the present invention comprises recording heads for ejecting different colored inks independently, a carriage having the recording heads and reciprocating in a scanning direction (X axis direction), a plurality of ink tanks aligned in the scanning direction and containing respective colors of ink to be supplied to the recording heads, ink supplying tubes routed from the carriage to the ink tanks via travel space for the carriage reciprocating, thereby coupling the carriage to the ink tanks, and a coupling section disposed on the ink tank side of the carriage travel space and bundling the ink supplying tubes. Among the plurality of ink tanks, the tank containing the most consumed ink is placed closest to the coupling section. The ink ejected from the recording heads is attached to a recording paper transferred in a transfer direction (Y axis direction) perpendicular to the scanning direction, thereby performing the recording.

Still another inkjet recording apparatus of the present invention comprises recording heads for ejecting ink, a carriage having recording heads and for reciprocating in a scanning direction (X axis direction), ink tanks containing ink to be supplied to the recording heads, and ink supplying tubes for coupling the carriage to the ink tanks. The ink supplying tubes are coupled to a side of the carriage in a transfer direction (Y axis direction) perpendicular to the scanning direction, i.e., a side section of the carriage in Y direction. The ink supplying tube is also bowed toward a first side in the scanning direction (X axis direction) at a space adjacent to the carriage moving space on the side of Y direction. When the carriage is placed at the end of the first side of the scanning direction, an end position of the bowed section is placed at approximately the same position as the end of the first side in the scanning line, or the end position of the bowed section is placed on a second side from the end of the first side in X axis direction.

The present invention can provide inkjet recording apparatuses in which high-speed recording and downsizing of the apparatus are compatible thanks to the structures discussed above.

BRIEF DESCRIPTION OF THE DRAWINGS

FIG. 1 is a schematic perspective view of an inkjet recording apparatus in accordance with a first exemplary embodiment of the present invention.

FIG. 2 is a schematic perspective view of ink supplying tubes of the inkjet recording apparatus shown in FIG. 1.

FIG. 3 is a schematic perspective view of ink supplying tubes of an inkjet recording apparatus in accordance with a second exemplary embodiment of the present invention.

FIG. 4 is a schematic perspective view of a modification of the ink supplying tubes in the same apparatus shown in FIG. 3.

4

FIG. 5 is a schematic perspective view of ink supplying tubes of an inkjet recording apparatus in accordance with a third exemplary embodiment.

FIG. 6 is a schematic perspective view of an ink supplying tubes of an inkjet recording apparatus in accordance with a fourth exemplary embodiment.

FIG. 7 is a plan view of an inkjet recording apparatus in accordance with a fifth exemplary embodiment.

FIG. 8 is a perspective view of the inkjet recording apparatus in accordance with the fifth exemplary embodiment.

FIG. 9 is an enlarged view of recording heads of the apparatus shown in FIG. 8.

FIG. 10 is a perspective view of an inkjet recording apparatus in accordance with a sixth exemplary embodiment.

FIG. 11 is a perspective view of an inkjet recording apparatus in accordance with a seventh exemplary embodiment.

FIG. 12 is a perspective view of an inkjet recording apparatus in accordance with an eighth exemplary embodiment.

FIG. 13 is a perspective view of an inkjet recording apparatus in accordance with a ninth exemplary embodiment.

FIG. 14 is a lateral view of an inkjet recording apparatus in accordance with a tenth exemplary embodiment.

FIG. 15 is a plan view of the inkjet recording apparatus shown in FIG. 14.

FIG. 16 is an enlarged view of recording heads of the apparatus shown in FIG. 14.

FIG. 17 is a lateral view of a first modification of the inkjet recording apparatus in accordance with the tenth embodiment.

FIG. 18 is a lateral view of a second modification of the inkjet recording apparatus in accordance with the tenth embodiment.

FIG. 19 is a lateral view of an inkjet recording apparatus in accordance with a eleventh exemplary embodiment.

FIG. 20 is a plan view of the inkjet recording apparatus in accordance with the eleventh exemplary embodiment.

DETAILED DESCRIPTION OF THE EXEMPLARY EMBODIMENTS

Exemplary embodiments of the present invention are demonstrated hereinafter with reference to the accompanying drawings.

First Exemplary Embodiment

FIG. 1 is a schematic perspective view of an inkjet recording apparatus in accordance with a first exemplary embodiment of the present invention. FIG. 2 is a schematic perspective view of ink supplying tubes of the inkjet recording apparatus shown in FIG. 1.

In the inkjet recording apparatus shown in FIG. 1, recording heads 1 eject inks of a plurality of colors. These heads 1 comprise black-ink-ejecting section 1a, yellow-ink-ejecting section 1b, magenta-ink-ejecting section 1c and cyan-ink-ejecting section 1d. These ejecting sections 1a, 1b, 1c and 1d are aligned in a moving direction of carriage 4 (X direction shown in FIG. 1.)

On the lower faces of each ejecting section, a plurality of nozzles 1e, having the same diameter, are formed as shown in FIG. 2. FIG. 2 illustrates schematically the details of ink-supplying-tubes 27-30, such as a diameter, number of

nozzles, length, and the like. The positional relation between the heads **1** and ink tanks **26** and curvatures the of tubes **27-30** are different from those shown in FIG. **1**.

Pressuring chambers (not shown) in which the ink is filled are provided at places corresponding to each nozzle **1e** in respective ejecting sections. Piezoelectric actuators (not shown) are also provided at the same places, and they have a piezoelectric element to which pulse-shaped voltage is applied, thereby reducing a capacity of the pressuring room, which results in deforming the pressuring room. This piezoelectric actuator is activated by a driving circuit **2**, so that ink in the pressuring chamber is ejected through the nozzle **1e** to recording paper **16** located under the nozzles **1e**. The recording paper **16** is transferred by a transfer motor **19** in Y direction, shown in FIG. **1**.

A number of nozzles **1e** assigned to black ink (a specified color) ejecting section **1a** is greater than those to other ejecting sections **1b**, **1c** and **1d**. Therefore, the amount of black ink per unit time ejected from nozzles **1e** of ejecting section **1a** is greater than those of inks of other colors ejected from nozzles **1e** of other ejecting sections.

The head **1** is rigidly mounted to the carriage **4** which is movable relative with respect to the recording paper **16**. The carriage **4** forms right angles with a transfer direction (Y direction) of the paper **16** and is disposed on a first side of a direction (X direction shown in FIG. **1**) along the paper **16**. The carriage **4** is mounted to a guide shaft **9** such that the shaft **9** extends through the carriage **4**, and is fixed at a span under a carriage driving belt **8**. The belt **8** is wound on a driver pulley **6** driven by carriage driving motor **5** disposed on a first side and a follower pulley **7** disposed on a second side. The shaft **9** is supported by the apparatus itself (not shown) and extends along the X axis. This structure allows the pulley **6** to rotate, thereby driving the belt **8**, and then the carriage **4**, i.e., the recording head **1** reciprocates in X direction being guided by the shaft **9**. The motor **5** includes a rotary detector **10** which is combined with a detecting sensor (not shown) to detect a rotational volume of the motor **5**, i.e., a position of the head **1** in the X direction.

The paper **16** is pinched between a transfer roller **17** and a pressure roller **18**. Both of the rollers extend in the X direction, and the roller **18** is urged to an upper surface of the roller **17** by a given pressure. The transfer motor **19** is disposed at a rear side of the transfer direction of the paper **16** with respect to the roller **18**. The rotation of the motor **19** is transmitted to the roller **17** via a gear row **20**. Rotation of the roller **17** transfers the paper **16** in the Y direction. The motor **19** includes a rotary detector **21** which is combined with a detecting sensor (not shown) to detect a rotational volume of the motor **19**, i.e., the transferred volume of the paper **16** in the Y direction.

Between the roller **18** and the motor **19**, there are ink tanks **26** containing ink of respective colors fixed to the apparatus itself (not shown). In other words, the ink tanks **26** are not disposed on the carriage **4** (recording head **1**), but disposed somewhere to the apparatus itself other than the carriage **4**. The tank **26** comprise four individual tanks the, including a black ink tank **26a**, a yellow ink tank **26b**, a magenta ink tank **26c**, and a cyan ink tank **26d**. These four individual tanks are aligned in the X direction.

The four ink-supplying-tubes **27-30** couple the head **1** to the tanks **26** and the tubes supply the ink of respective colors in the individual tanks to the heads **1**. The tube **27** couples the black ink ejecting section **1a** of the head **1** to the black ink tank **26a**, and the tube **28** couples the yellow ink ejecting section **1b** to the yellow ink tank **26b**. The tube **29** couples the magenta ink ejecting section **1c** to the magenta ink tank

26c, and the tube **30** couples the cyan ink ejecting section **1d** to the cyan ink tank **26d**. A coupling member **33** is disposed near the front side of the tanks **26** with respect to the transfer direction of the paper **16**. These four tubes **27-30** are bundled in the vertical direction by the coupling member **33**. The tubes extend in the Y direction, then extend toward the second side in the X direction, i.e., toward the pulley **7** side, then curve and extend toward the first side in the X direction, i.e., toward the pulley **6** side, and finally arrive at the head **1**. Thus, when the head **1** moves in the X direction together with the carriage **4**, curved sections of the tubes **27-30** move so that the tubes **27-30** do not prevent the head **1** from moving. The tubes **27-30** between the coupling member **33** and the head **1** are vertically adjacent, and in approximate contact with each other. However, they are not bonded (they can be bonded).

The black ink supplying tube **27** supplies a greater amount of ink than the other tubes **28-30**. To be more specific, the tubes **28-30** for yellow, magenta and cyan inks have the same diameter, while the tube **27** for black ink has a larger diameter along the entire length.

This structure allows the black ink to flow in a greater amount than the other colored inks, and allows the fluid resistance in the tube **27** to lower. Thus, the supplying amount of black ink per unit time can be greater than other colored inks. As a result, black ink can be supplied to the black ink ejecting section **1a** without fail although a number of nozzles **1e** as the ejecting section **1a** is greater than those of the other ejecting sections **1b**, **1c** and **1d**, as well as, the ejected amount of black ink per unit time is greater than other inks. On the other hand, since only tube **27** among others is enlarged in its diameter, the apparatus is restrained from becoming larger. As such, the printing speed with black ink can be faster, while a size of the apparatus is restrained from becoming larger.

In this first embodiment, the diameter of the tube **27** is greater than the other tubes **28-30** along the entire length. However, when only a part of the tube has a greater diameter than the other tubes **28-30**, the fluid resistance the black ink bears decreases accordingly. Thus, the supply amount of black ink per unit time can be greater than the other colored inks.

Second Exemplary Embodiment

FIG. **3** is a schematic perspective view of ink supplying tubes of an inkjet recording apparatus in accordance with the second exemplary embodiment of the present invention.

In FIG. **3**, the same elements shown in FIG. **2** bear the same reference marks, and descriptions thereof are, thus, omitted. In the second embodiment, the black ink supplying tube **27** shown in FIG. **2** of the first embodiment is modified. To be more specific, in the second embodiment, two pieces of the tube **27** are provided, i.e. a greater number of black ink supplying tubes than other tubes for other colored inks are available. The two tubes are independently formed, and their diameters are the same as those of the other tubes **28-30**.

Therefore, in this second embodiment, the flowing amount of the black ink is greater than those of other colored inks, and the supply amount of the black ink per unit time can be greater than those of other colored inks. As a result, the same advantage as the first embodiment is obtainable.

FIG. **4** is a schematic perspective view of a modification of the ink supplying tube in accordance with the second embodiment of the present invention. In the second embodiment, the two tubes **27** are independently formed; however, in the modification shown in FIG. **4**, two tubes **27** are

integrated into one unit. Three or more of the tubes 27 can be provided. In this case, all of the tubes can be integrated into one unit, or at least two of them can be integrated into one unit.

Third Exemplary Embodiment

FIG. 5 is a schematic perspective view of ink supplying tubes of an inkjet recording apparatus in accordance with the third exemplary embodiment.

In FIG. 5, the same elements shown in FIG. 2 bear the same reference marks, and descriptions thereof are thus omitted. In this third embodiment, the respective ink-supplying-tubes 27 30 have the same diameter and the same number of tubes are assigned to respective colors. However, the tube 27 for black ink has a shorter length than the other tubes 28-30.

To be more specific, the black ink tank 26a is disposed away from the other tanks 26b, 26c and 26d. The black ink supplying tube 27 is routed in a different way from other tubes, such as not via the coupling member 33, and arrives at the black ink ejecting section 1a of the head 1.

The shorter length of the tube 27 allows the black ink to bear a large fluid resistance within a shorter length than other colored inks which travel in the longer length of the tubes 28-30. Therefore, the supply amount of black ink per unit time can be greater than other colored inks. As a result, the same advantage as the first and second embodiments can be obtained.

In the first through the third embodiments, a number of the nozzles 1e of black ink ejecting section 1a is greater than those of the other ejecting sections 1b, 1c and 1d. However, if the number of nozzles is the same as the others, a diameter of the nozzle 1e can be greater than those of the others, or a waveform of a voltage applied to the piezoelectric element corresponding to the nozzle 1e can be changed from those of other nozzles. Thus, a supply amount of the black ink per unit time can be greater than those of other colored inks.

A supply amount of any specific color per unit time can be increased, and it is not limited to the black color. The specific color is not always one color, and two or more colors can be assigned to the specific colors. A supply amount from any specific colored ink supplying tube per unit time can be greater than those of other supplying tubes.

Fourth Exemplary Embodiment

FIG. 6 is a schematic perspective view of an ink supplying tubes of an inkjet recording apparatus in accordance with the fourth exemplary embodiment.

In FIG. 6, the same elements shown in FIG. 2 bear the same reference marks, and descriptions thereof are, thus, omitted. In this fourth embodiment, viscosity of black ink is greater than those of other colored inks. To be more specific, the colored inks other than, the black ink employ dye type inks, while the black ink employs a pigment type ink of which the viscosity is greater than that of the dye type.

A supply amount from black ink supplying tube 227 per unit time is not less than those of other tubes 228-230. In other words, the diameter of the tube 227 is larger than those of the other tubes 228-230 along the entire length. Also, only a part of the tube 227 can have a greater diameter than others.

This structure allows the supply amount of the black ink to be not less than those of the other colored inks, although the viscosity of the black ink is greater than those of the other colored inks. As a result, the black ink can be posi-

tively supplied to its ejecting section 1a without lowering printing speed, so that clear and crisp printing in black ink can be achieved.

In this fourth embodiment, the diameter of the tube 227 is greater than those of tubes 228-230. However, as demonstrated in the second embodiment, the number of the tubes 227 can be greater than numbers of the other tubes 228-230, or as demonstrated in the third embodiment, the length of the tube 227 can be shorter than those of the other tubes 228-230. In this fourth embodiment, a pigment type ink is used as the black ink; however, it is not limited to the pigment type, but the viscosity of the black ink can be greater than the other inks in any way. A specific color having a greater viscosity is not limited to the black ink, and other inks can have a greater viscosity. The specific color is not always limited to one color, and two or more colors can be available to the specific color, and the supply amount from the specific colored ink supplying tube can be not less than those from other colored ink supplying tubes.

As discussed above, in the inkjet recording apparatus in accordance with the first through the fourth embodiment, an ejected amount of a specific colored ink from the nozzles per unit time is set greater than those of other colored inks. The ink-supplying-tube for the specific colored ink is designed to supply a greater amount of ink per unit time than other ink-supplying-tubes. In another inkjet recording apparatus, a viscosity of a specific colored ink is set greater than those of other colored inks, and the ink-supplying-tube for the specific colored ink is designed to supply a greater amount of ink per unit time than other ink-supplying-tubes. According to the first through the fourth embodiments, the apparatus is restrained from being greater size, while a specific colored ink is positively supplied to a recording head. As a result, printing speed with the specific colored ink can be increased, or a clear printing in the specific colored ink is obtainable.

Fifth Exemplary Embodiment

FIG. 7 is a plan view of an inkjet recording apparatus in accordance with the fifth exemplary embodiment. FIG. 8 is a perspective view of the same apparatus. FIG. 9 is an enlarged view of recording heads of the apparatus shown in FIG. 8.

As shown in FIGS. 7 and 8, inkjet recording apparatus A ejects the inks of yellow, magenta, cyan and black, respectively, from recording heads 100 to recording paper 410, thereby performing color recording on the paper 410.

Heads 100 are provided to a carriage 310, and a scanner 300 reciprocates the carriage 310 in a scanning direction (X direction shown in FIG. 8). A transfer machine 400 transfers recording paper 410 in a transfer direction (Y direction shown in FIG. 8) perpendicular to the scanning direction.

A carriage moving space 310a the space where the carriage 310 reciprocates in the scanning direction extends in the scanning direction. The carriage 310 reciprocates within the space 310a in the scanning direction, so that the heads 100 also reciprocate in the scanning direction. The scanner 300 comprises a carriage shaft 320 for guiding the carriage 310, a carriage driving motor 330 as a driving source for reciprocating the carriage 310, and a carriage driving belt 340 for transferring the carriage 310.

The shaft 320 is disposed extending in the scanning direction. The carriage 310 is mounted to the shaft 320 so that the carriage 310 moves along the shaft 320 being guided by the shaft 320. The belt 340 winds on a driver pulley 340a and a follower pulley 340b spaced from each other in the scanning direction.

The motor 330 is adjacent to the space 310a with respect to the transfer direction and disposed on a first side of the scanning direction. As shown in FIG. 8, the motor 330 is disposed on the side of the carriage 310 with respect to the transfer path, i.e., an upstream side in the ink ejecting direction with respect to the transfer path (Z direction shown in FIG. 8). The pulley 340a is mounted to a rotary shaft of the motor 330, and spinning of the motor 330 causes the pulley 340a to spin. The spin of the pulley 340a is transferred to the pulley 340b via the belt 340.

On the carriage 310, an engaging section 310b for engaging with the belt 340 is formed. When the belt 340 is driven, the engaging section 310b is transferred by the belt 340, therefore, the rotary shaft of the motor 330 is normally driven or reversedly driven, so that the carriage 310 reciprocates in the scanning direction. The transfer machine 400 comprises a transfer motor 420 as a driving source for transferring the medium 410 a transfer rotor 430 and a pressing rotor 440 both for pinching and transferring the paper 410. The motor 420 is adjacent to the space 310a in the transfer direction and disposed on a second side of the scanning direction. In other words, the motor 420 is disposed away from the motor 330 in the scanning direction. Therefore, the motor 330 and the motor 420 are disposed at respective corners of apparatus A. (Refer to two-dot chain lines in FIG. 7.)

The motor 420 is disposed on upstream side in the ink ejecting direction (Z direction shown in FIG. 8) with respect to the transfer path. In other words, as shown in FIG. 8, the motor 420 and the motor 330 are disposed at approximately the same place on the Z axis. The roller 430 is disposed extending in the scanning direction, and has a gear on its tip. The gear engages with a plurality of gears 450 in series and finally engages with the rotary shaft of the motor 420. This structure allows the roller 430 to rotate around the rotary shaft of the motor 420 when the rotary shaft of the motor 420 spins. The roller 440 faces the roller 430, and urges the paper 410 against the roller 430. Thus, when the motor 420 spins, the paper 410 pinched between the roller 430 and the roller 440 is transferred in the transfer direction.

On each shaft of the motor 330 and the motor 420, rotary detectors 330a and 420a are mounted. In order to detect a rotating angle of the rotary detectors 330a and 420a, rotating angle detecting sensors 330b and 420b are disposed and face the rotary detectors. The motor 330 and the motor 420 are controlled based on rotating angles of respective rotary shafts thereof. The rotating angles are detected by the sensors 330b and 420b. Controlling of both the motors also controls the position of the carriage 310 and the position of the paper 410. These two motors are rather high power motors and have rather large shapes.

The recording head 100 disposed to the carriage 310 is now described. FIG. 9 is an enlarged view of the recording head of the apparatus. The head 100 comprises a plurality of pressuring chambers 110 in which colored inks such as yellow, magenta, cyan and black are filled, a plurality of nozzle-holes 120 disposed on walls defining the respective chambers 110, and for ejecting the inks from the chambers 110, and actuators 130 actuating and deforming so that capacities of the respective chambers 110 decrease.

Ink flow-paths 110a, through which the ink is supplied, communicate with the chambers 110. These paths 110a are coupled to a sub-tank 510 mounted to the carriage 310.

The actuators 130 are disposed on the walls of the chambers 110 facing the walls on which the nozzle-holes 120 are formed. The actuators 130 are formed by piezoelectric film pinched by a pair of electrodes. A pulse is applied

over the pair of electrodes, and a rise of pulse voltage makes the actuator 130 bow downward (protrudes inside of the chamber 110) due to a bimetal effect. This deflection ejects the ink in the chamber 110 through the nozzle-hole 120 toward the paper 410. On the other hand, a fall of pulse voltage restores the actuator 130, then ink is filled in the chamber 110 through the flow path 110a. The voltage applied to the actuator 130 is controlled by a head driving circuit 150 disposed on the carriage 310. The driving circuit 150 controls the deforming of the actuator 130, so that ejection of the ink is controlled.

Sub-tanks 510 are provided for respective colored inks. As shown in FIGS. 7 and 8, the sub-tanks 510 are mounted to the carriage 310 and reciprocate together with the carriage 310 in the space 310a in the scanning direction. Ink supplying tubes 520 (four tubes in total) of respective colors are coupled to each of the sub-tanks 510. These tubes 520 are aligned in an ejecting direction (Z axis direction) and integrated into one unit. The tubes 520 run through the space 310a and arrive at a coupling member 520a disposed at approximately the center in the scanning direction (X axis direction.) At the coupling member 520a, the tubes 520 are separated into respective colors, and coupled to respective main tanks 530 containing respective colored inks. The respective main tanks 530 are divided into four respective colors and aligned in the scanning direction (X axis direction), and placed between the motor 330 and the motor 420. In the Z axis direction, the tanks 530 are disposed on the same side as the carriage 310 is disposed with respect to the transfer path.

Regarding the four supplying tubes 520 extending between the coupling member 520a and the carriage 310, power lines for the driving circuit 150 and other wires for signals (not shown) are integrally routed in parallel with the tubes 520.

An operation and advantages of the fifth embodiment are demonstrated hereinafter. As shown in FIG. 8, the carriage driving motor 330 and the transfer motor 420 do not interfere with each other on the transfer path of the paper 410, because both of the motors are disposed on the same side that the carriage 310 is disposed with respect to the transfer path in the ejecting direction (Z axis direction) viewed from the scanning direction (X axis direction).

Further, since both of the motors are disposed at approximately the same place regarding the Z axis direction, a space for one motor can accommodate the two motors in the Z axis direction. Therefore, the apparatus A can be downsized substantially in the Z axis direction.

As discussed above, since both of the motors are disposed on the same side that the carriage 310 is disposed with respect to the transfer path, both of the motors can be placed in a space adjacent to the carriage-moving-space 310a. Therefore, no additional space is required only for accommodating both of the motors. As a result, even if both of the motors are rather large in size, the apparatus A can be downsized.

Still further, both of the motors generate heat due to operation; however since they are disposed away from each other in the scanning direction (X axis direction), the apparatus A does not encounter a local high temperature. Thus, troubles due to heat can be avoided.

Both of the motors are away from each other in the scanning direction, thus, the main tanks 530 can be disposed in a space extending between both of the motors. Therefore, no additional space is required only for accommodating the tanks 530. As a result, the apparatus A can be downsized in both the ejecting direction and transfer direction.

11

The space between both of the motors is rather large, thus, the capacities of the tanks **530** can be increased. This is convenient for a certain type of tanks **530**, which ejects a greater amount of ink per unit time at higher recording speed. Further, the tanks **530** are disposed at a place adjacent to the carriage moving space **310a** in the transfer direction. Thus, the length of the ink-supplying-tubes **520** becomes short, and flow path resistance in the tubes **520** against the ink becomes less, so that the ink can be supplied in a stable manner to the recording head **100**. As a result, stable recording is achievable, and a high-speed of the apparatus A is obtainable.

The fifth embodiment proves that even if the carriage driving motor **330** and the transfer motor **420** are large in size, the apparatus A can be downsized in both the ejecting direction (Z axis direction) and the transfer direction (Y axis direction). Thus, higher recording speed and downsizing of the apparatus are compatible.

Sixth Exemplary Embodiment

FIG. **10** is a perspective view of an inkjet recording apparatus in accordance with the sixth exemplary embodiment. The sixth embodiment differs from the fifth embodiment in the following point.

In apparatus A shown in FIG. **8** used in the fifth embodiment, the main tanks are placed between the carriage driving motor and the transfer motor. However, in ink-jet-recording apparatus B used in the sixth embodiment, shown in FIG. **10**, a battery pack **610**, as a power source, is placed between the carriage driving motor **330** and the transfer motor **420**. In other words, the main tanks are omitted in this sixth embodiment, and the apparatus B has only the ink tanks **540** mounted to the carriage **310**. The battery pack **610**, instead, is placed between both the motors and on the same side that the carriage **310** is disposed. The battery pack **610** powers the scanner **300**, the transfer machine **400** and the like.

Other structures of the apparatus B remain the same as that used in the fifth embodiment, and the same elements bear the same reference marks and the descriptions thereof are thus omitted here. The apparatus B in accordance with the sixth embodiment is good as a portable ink-jet-recording apparatus. The space between both of the motors is used for accommodating the battery pack **610**, thus a high-speed ink-jet-recording apparatus of a compact size is obtainable.

Seventh Exemplary Embodiment

FIG. **11** is a perspective view of an inkjet recording apparatus in accordance with the seventh exemplary embodiment. The seventh embodiment differs from the fifth embodiment in the following point.

In the apparatus A, shown in FIG. **8**, used in the fifth embodiment, the main tanks are placed between the carriage driving motor and the transfer motor. However, in ink-jet-recording apparatus C used in the seventh embodiment, shown in FIG. **11**, an electric circuit **620**, as a controller, is placed between carriage driving motor **330** and the transfer motor **420**.

The apparatus C used in the seventh embodiment omits the main tanks and has only the ink tanks **540** mounted to the carriage **310**, and the circuit **620** controlling scanner **300**, the transfer machine **400** and the like is placed between both of the motors. The circuit **620** is placed on the same side that the carriage **310** is placed with respect to the transfer path.

The other structure of the apparatus C remains the same as that used in the fifth embodiment, and the same elements

12

bear the same reference marks and the descriptions thereof are, thus, omitted here. The space between both of the motors is used for accommodating the circuit **620**, thus a high-speed ink-jet-recording apparatus with a compact size is obtainable.

Eighth Exemplary Embodiment

FIG. **12** is a perspective view of an inkjet recording apparatus in accordance with the eighth exemplary embodiment. The eighth embodiment differs from the fifth embodiment in the following point.

In the apparatus A, shown in FIG. **8**, used in the fifth embodiment, the main tanks are placed between the carriage driving motor and the transfer motor. However, in ink-jet-recording apparatus D used in the eighth embodiment shown in FIG. **12**, a feeder **630** for feeding the paper **410** to the transfer machine **400** is placed between the carriage driving motor **330** and the transfer motor **420**.

The apparatus D used in the eighth embodiment omits the main tanks and has only the ink tanks **540** mounted to the carriage **310**, and the feeder **630** is instead placed between both of the motors. The feeder **630** is placed on the same side that the carriage **310** is placed with respect to the transfer path. The feeder **630** holds a plurality of the paper **410** and supplies the paper **410** one by one to the transfer machine **400**.

Other structures of the apparatus D remain the same as that used in the fifth embodiment, and the same elements bear the same reference marks and the descriptions thereof are, thus, omitted here. The space between both of the motors is used for accommodating the feeder **630**, thus a high-speed ink-jet-recording apparatus with a compact size is obtainable.

Ninth Exemplary Embodiment

FIG. **13** is a perspective view of an inkjet recording apparatus in accordance with the ninth exemplary embodiment. The ninth embodiment differs from the fifth embodiment in the following point.

In the apparatus A, shown in FIG. **8**, used in the fifth embodiment, the main tanks are placed between the carriage driving motor and the transfer motor. However, in ink-jet-recording apparatus E used in the ninth embodiment, shown in FIG. **13**, the space between carriage the driving motor **330** and the transfer motor **420** is used as a tank moving space **550c**. The ink tank **550** used in the ninth embodiment comprises the first tank **550a** mounted to the carriage **310** and the second tank **550b** provided in a transfer direction with respect to the first tank **550a**. The second tank **550b** is integrated into the first tank so that it communicates with the first tank **550a**. The second tank **550b** is disposed between both of the motors and on the same side that the carriage **310** is placed with respect to a transfer path. This structure allows the second tank **550b** to reciprocate in the space **550c**, while the first tank **550a** reciprocates within the carriage-moving-space **310a** following the reciprocation of the carriage **310**.

The other structures of the apparatus E remain the same as that used in the fifth embodiment, and the same elements bear the same reference marks and the descriptions thereof are thus omitted here. In this ninth embodiment, since the ink-tank **550** has the first tank **550a** and the second tank **550b**, the total capacity is greater than those of previous embodiments. Further, the second tank **550b** is placed between both of the motors, thus the capacity thereof can be large. Therefore, the apparatus E can be downsized in an

ejection direction (Z axis direction) and the transfer direction (Y axis direction.) As a result, a high-speed recording apparatus can be downsized.

In the fifth through the ninth embodiments, the carriage driving motor **330** and the transfer motor **420** are disposed on the same side that the carriage **310** is placed with respect to the transfer path. However, it is not limited to this structure, and both of the motors can be placed above the transfer path in the Z axis direction viewed from a scanning direction (X axis direction.) In this case, the apparatus E can be downsized in the ejecting direction (Z axis direction.)

In the fifth through ninth embodiments, the carriage driving motor **330** is placed so that its rotary shaft faces toward the transfer direction. However, it is not limited to this structure, and the motor **330** can be placed so that the rotary shaft faces toward the scanning direction. In the same manner, the transfer motor **420** is placed so that its rotary shaft faces toward the scanning direction. However, the motor **420** can be placed so that the rotary shaft faces toward the transfer direction. Further, the locations of both of the motors can be exchanged with respect to the scanning direction.

As discussed above, the inkjet recording apparatuses in accordance with the fifth through the ninth embodiments prove that when the carriage driving motor and the transfer motor are disposed at approx. the same place in the ejecting direction (Z axis direction) and above the transfer path, or disposed on the same side as the carriage is placed in Z axis direction, the apparatuses can be downsized even if both the motors are in large shapes. Therefore, a high-speed and compact recording apparatus is obtainable. Further, when both the motors are away from each other in the scanning direction, and various elements forming the apparatus are disposed in the space between both the motors, the apparatus can be downsized in both the ejecting direction (Z axis direction) and the transfer direction (Y axis direction.)

High-speed recording and a compact size can be thus compatible in an inkjet recording apparatus.

Tenth Exemplary Embodiment

FIG. **14** is a lateral view of an inkjet recording apparatus in accordance with the tenth exemplary embodiment. FIG. **15** is a plan view of the inkjet recording apparatus shown in FIG. **14**. FIG. **16** is an enlarged view of recording heads of the apparatus shown in FIG. **14**. FIG. **17** is a lateral view of a first modification of the inkjet recording apparatus in accordance with the tenth embodiment. FIG. **18** is a lateral view of a second modification of the inkjet recording apparatus.

In the apparatus used in the tenth embodiment shown in FIGS. **14** and **15**, colored inks such as yellow, magenta, cyan and black are ejected from recording heads **1000** to a recording medium such as a sheet of paper **4100**, so that color recording is carried out on the paper **4100**.

The heads **1000** are disposed at a carriage **3100**. A scanner **3000** reciprocates the carriage **3100** in a scanning direction (X direction.) A transfer machine **4000** transfers the paper **4100** in a transfer direction (Y direction) perpendicular to the scanning direction.

A carriage-moving-space **3100a**, for the carriage **3100** to reciprocate in the scanning direction, extends in the scanning direction. The carriage **3100** reciprocates within the space **3100a** in the scanning direction, so that the head **1000** also reciprocates in the scanning direction. The scanner **3000** comprises a pair of carriage shafts **3200** for guiding the carriage **3100**, a carriage driving motor **3300**, and a carriage

driving belt **3400** for transferring the carriage **3100**. This pair of carriage shafts **3200** extend in the scanning direction and are disposed in parallel with the transfer direction. The pair of shafts **3200** extend through and guide the carriage **3100**, so that the carriage **3100** moves along the pair shafts **3200**.

The belt **3400** winds on a driver pulley **3400a** and a follower pulley **3400b** spaced from each other in the scanning direction. The motor **3300** is adjacent to the space **3100a** with respect to the transfer direction and disposed on a first side of the scanning direction. As shown in FIG. **14**, the motor **3300** is disposed on the side of the carriage **3100** with respect to the transfer path, i.e., upstream side in the ink ejecting direction with respect to the transfer path (Z direction shown in FIG. **14**). The pulley **3400a** is mounted to a rotary shaft of the motor **3300**, and spinning of the motor **3300** causes the pulley **3400a** to spin. The spin of the pulley **3400a** is transferred to the pulley **3400b** via the belt **3400**.

On the carriage **3100**, engaging section **3100b** for engaging with belt **3400** is formed. When belt **3400** is driven, an engaging section **3100b** is moved by the belt **3400**. Therefore, the rotary shaft of the motor **3300** is normally driven or reversedly driven, so that the carriage **3100** reciprocates in the scanning direction.

A frame **6100**, of which cross sectional view shapes in a reversed letter "L", is placed such that it extends in the scanning direction between the space **3100a** and the motor **3300**, and defines the space **3100a**. At the bent section on the upper end of the frame **6100**, a linear scale **7100** is disposed for detecting a position of the carriage **3100** with respect to the scanning direction. In other words, the scale **7100** is located above the carriage **3100** and extends in the scanning direction.

On the other hand, on the upper face of the carriage **3100**, a detecting sensor **7200** is disposed. The sensor **7200** faces the linear scale **7100** to detect it. The sensor **7200** detects a position of the carriage **3100** in the scanning direction, and based on this detected position, rotational control of the motor **3300** is performed.

The transfer machine **4000** comprises a transfer motor **4200**, which is a driving source for transferring the recording paper **4100**, a pair of transfer rollers **4300** for pinching the paper **4100** for transfer, and a pair of discharging rollers **4550** for pinching and discharging the paper **4100**. The motor **4200** is disposed at a place adjacent to the space **3100a** and on a second side of the scanning direction. In other words, as shown in FIG. **15**, the motor **4200** is away from the motor **3300** in the scanning direction (X direction.) The pair of rollers **4300** facing each other extend, respectively, in the scanning direction. One of the rollers **4300** is coupled to a rotating shaft of the motor **4200** via a plurality of gears **4500**. Thus, this roller **4300** rotates around the motor shaft following the rotation of the shaft of the motor **4200**.

The pair of discharging rollers **4550**, facing each other, extend respectively, in the scanning direction, and are disposed in parallel with the pair of rollers **4300** in the transfer direction. Pulleys **4600a** and **4600b** are disposed, respectively, at the end of one of the pair of rollers **4300** and pair-rollers **4550**. This pair of pulleys have the same diameter, and a transmission belt **4600** winds on these pulleys. This structure allows the roller **4550** to rotate by the belt **4600** at the same rotating speed and in the same direction as the roller **4300**, simultaneously.

Accordingly, when the motor **4200** spins, the paper **4100** pinched by the pair of rollers **4300** is transferred to just under the heads **1000**, while another piece of the paper **4100**

pinched by the pair-rollers **4550** is discharged from just under the heads **1000** in the transfer direction.

Between the rollers **4300** and the rollers **4550**, a platen **4700** is disposed on the reverse side of the head **1000** with respect to the paper **4100**, so that wrinkles or looseness of the paper **4100** can be prevented. Thus, a quality picture can be recorded.

Recording heads **1000** disposed to the carriage **3100**, as shown in FIG. **16**, comprise a plurality of pressuring chambers **1100** in which colored inks such as yellow, magenta, cyan and black are filled, a plurality of nozzle-holes **1200** disposed on walls defining the respective chambers **1100**, and for ejecting the inks from the chambers **1100**, and actuators **1300** actuating and deforming so that capacities of the respective chambers **1100** decrease.

Ink flow-paths **1100a**, through which the ink is supplied, communicate with the chambers **1100**. These paths **1100a** are coupled to a ink-tank **5300** via ink-supplying-tubes **5200**.

The actuators **1300** is disposed on the walls of the chambers **1100** facing the walls on which the nozzle-holes **1200** are formed. The actuators **1300** are formed by piezo-electric film pinched by a pair of electrodes. A pulse is applied over the pair of electrodes, and a rise of pulse voltage makes the actuator **1300** bow downward (protrudes inside of the chamber **1100**) due to the bimetal effect. This deflection ejects the ink in the chamber **1100** through the nozzle-hole **1200** to the paper **4100**. On the other hand, a fall of pulse voltage restores the actuator **1300**, then ink is filled in the chamber **1100** through the flow path **1100a**.

The voltage applied to the actuator **1300** is controlled by a head driving circuit **1500**. The driving circuit **1500** controls the deforming of the actuator **1300**, so that ejection of the ink is controlled. The ink tanks **5300** accommodate respective colored ink independently, and are aligned in the scanning direction at a place adjacent to the space **3100a** in the transfer direction, as shown in FIGS. **14** and **15**. Thus, the tanks **5300** are located on the same side as the motor **3300** with respect to the space **3100a**. As such, the four tanks **5300** are aligned in the scanning direction, thereby increasing respective capacities of the tanks **5300**.

The tubes **5200** are provided to respective colored inks, and the four tubes **5200** are aligned in the ejecting direction (Z axis direction) and integrated into one unit. The tubes **5200** are coupled to the carriage **3100** on the other side of the tanks **5300** with respect to the transfer direction, and bowed upward in the space **3100a** and arrive at the tanks **5300** on their sides closer to the space **3100a**. The tubes **5200** are routed outside of the space **3100a** via a coupling section **6100a** which is disposed at approximately the center of a frame **6100** in the scanning direction and above the carriage shaft **3200** as well as carriage the driving belt **3400** in the ejecting direction (Z axis direction). Thus, the tubes **5200** run above the carriage shaft **3200** and the belt **3400**. Outside of the space **3100a**, the tubes **5200** are separated to respective colors and coupled to the four tanks **5300**, independently.

Among a plurality of ink tanks **5300**, an ink tank, which contains the ink of the highest viscosity, is placed closest to the coupling section **6100a**, i.e., at the middle in the scanning direction (X axis direction.) The highest viscosity ink is, for instance, an ink of pigment system.

A tank containing the most consumable ink may be disposed closest to the coupling section **6100a**. The most consumable ink is usually black ink. From the coupling section **6100a** to the carriage **3100**, electric wiring **6200**, including power lines and others, is integrally routed along

the tubes **5200**. The wiring **6200** is coupled to the driving circuit **1500** of the carriage **3100**.

An operation and advantages of the tenth embodiment are demonstrated hereinafter.

Since the ink-supplying-tubes **5200** are routed through the carriage moving space **3100a**, no additional space for the tubes **5200** is specifically required. As a result, the apparatus can be downsized.

The tubes **5200** reciprocate within the space **3100a** following the reciprocation of the carriage **3100**. At this time, the tubes **5200** do not interfere with the reciprocation of the carriage **3100** and vice versa. (Refer to chain lines in FIG. **15**.) As a result, the ink is supplied to the recording heads **1000** supplied in a stable manner.

Further, the ink tanks **5300** and the carriage driving motor **3300** are placed on the same side as the space **3100a** with respect to the transfer direction (Y axis direction), thus the apparatus can be downsized in the transfer direction.

Still further, the tanks **5300** are disposed close to the carriage **3100**, therefore, the length of the tubes **5200** becomes short. As a result, flow-path resistance against the ink becomes less, thus the ink can be supplied to the recording heads **1000** in a stable manner.

The ink tank **5300**, containing the ink of the highest viscosity or the most consumable ink, is disposed at the middle of the tanks **5300** in the scanning direction (X axis direction), thus the ink can be supplied with the shorter tube length to the head **1000**. As a result, flow path resistance against the ink becomes less, and the apparatus achievable of stable recording can be obtained.

Further, the coupling section **6100a** is placed approximately at the center of the frame **6100** in the scanning direction (X axis direction), so that a flowing length of the tube **5200** disposed in the space **3100a** can be minimized. The flowing lengths of the tubes **5200** between the coupling section **6100a** and respective tanks can be approximately equal to each other. As a result, inks contained in any tanks can be supplied to the heads **1000** in a stable manner. In addition, the tubes **5200** are coupled to the carriage **3100** at a distant side in the transfer direction with respect to the tanks **5300**, which gives the tubes **5200** greater curvatures, and flow-path resistance against the ink decreases. As a result, the inks can be supplied to the heads **1000** in a stable manner.

The electric wiring **6200** is routed integrally with the tubes **5200**, so that no additional space is required for the wiring **6200**. As a result, the apparatus can be further downsized, and the electric wiring **6200** does not interfere with the moving of the carriage **3100** and the tubes **5200**.

First Modification

FIG. **17** illustrates an inkjet recording apparatus in accordance with the first modification. In this modification, the carriage shaft **3200** is disposed at a different place from the tenth embodiment. To be more specific, in this modification, a pair of carriage shafts **3200** are disposed in the ejecting direction (Z axis direction), and a pair of the ink-supplying-tubes **5200** are routed between the pair of carriage shafts **3200**.

The other elements and structures are the same as those in the tenth embodiment, and the same elements are denoted with the same reference marks. The descriptions thereof are, thus, omitted here. In this modification, no additional space is required for the routing tubes **5200**, which are routed in an optimum manner, so that the inks can be supplied to the heads **1000** in a stable manner.

FIG. 18 illustrates an inkjet recording apparatus in accordance with the second modification. In the second modification, a linear scale 7100 is disposed at a different place from the first modification. To be more specific, the scale 7100 is disposed on the depending wall of the frame 6100, i.e., disposed at the carriage 3100 on the side of the transfer direction, and a detecting sensor 7200, which detects the scale 7100, is disposed on the side of the carriage 3100 closer to the tanks 5300.

The other elements and structure are the same as those in the tenth embodiment, and the same elements are denoted with the same reference marks. The descriptions thereof are, thus, omitted here. The carriage shafts 3200, the linear scale 7100 and the carriage driving belt 3400 are, thus, placed so as not to interfere with the tubes 5200.

11th Exemplary Embodiment

FIG. 19 is a lateral view of an inkjet recording apparatus in accordance with the 11th exemplary embodiment. FIG. 20 is a plan view of the same inkjet recording apparatus.

This 11th embodiment tries downsizing the apparatus in a scanning direction. In FIG. 20, a plus side in the X direction is referred to as a first side of the scanning direction, and a minus side thereof is a second side of the scanning direction. The minus side in the Y direction is referred to as a first side of the transfer direction, and a plus side thereof is a second side of the transfer direction.

In the 11th embodiment, the ink-supplying-tubes 5200 are coupled to the carriage 3100 on its first side of the transfer direction (Y axis direction.) The tubes 5200 are routed through a slit 6100b formed on the frame 6100 and extending in the scanning direction (X axis direction), and adjacent to the carriage moving space 3100a on the first side of the transfer direction (Y axis direction.) Thus, the tubes 5200 bow upward (protrude) to the first side of the scanning direction.

The tubes 5200 are coupled to the carriage 3100 in parallel with an ejecting direction (Z axis direction.) The coupling section of the tubes 5200 to the carriage 3100 is set on the second side of the scanning direction on the carriage 3100, as shown in FIG. 20. The distance "L" between an end of the first side of the scanning direction on the carriage 3100 and the coupling section is longer than a curvature diameter "r" of the bowed section of the tubes 5200.

The tanks 5300 are placed adjacent to the space 3100a on the first side of the transfer direction (Y axis direction), and are disposed on the upstream side with respect to the tubes 5200 in the ejecting direction (Z axis direction.) The tubes 5200 are routed under the tanks 5300 in the ejecting direction, and coupled to the side of the respective tanks 5300 on the first side of the transfer direction via coupling sections 6300 apart from each other on the first side of the frame 6100 in the transfer direction. The coupling sections are located approximately at the center in the scanning direction (X axis direction.)

The carriage driving motor 3300 of the scanner 3000 is placed on the second side of the scanning direction (X axis direction), which differs from the tenth embodiment. In FIG. 20, the transfer machine 4000 is omitted; however, other structures, including the transfer machine 4000, are the same as that in the tenth embodiment. Thus, the same elements are denoted with the same reference marks and the descriptions thereof are, thus, omitted here.

In this 11th embodiment, the tubes 5200 are bowed at the place adjacent to the space 3100a on the first side of the transfer direction (Y axis direction), therefore, the tubes 5200 can have a rather large curvature diameter "r". As a result, flow path resistance against the ink is lowered and the ink can be supplied in a stable manner.

The coupling section of the tubes 5200 to the carriage 3100 is set on the second side of the scanning direction with reference to an end of the first side of the scanning direction on the carriage 3100 exceeding the curvature radius "r" (refer to distance "L" in FIG. 20.) Thus, when the carriage 3100 is moved to the end of the first side of the scanning direction in the space 3100a, the tubes 5200 bow at the place adjacent to the carriage 3100 on the first side of the transfer direction. The top of the bowed section will not extend in the scanning direction (X axis direction) from the first side of the scanning direction on the carriage 3100 (refer to solid lines in FIG. 20.) In other words, the tubes 5200 are placed on the second side of the scanning direction from the end of the first side of the scanning direction on the carriage 3100. As a result, the inkjet recording apparatus can be downsized in the scanning direction (X axis direction.)

The ink tanks 5300 are placed at the place adjacent to the space 3100a on the first side of the transfer direction, and placed on the upstream side of the ejecting direction (Z axis direction) with respect to the tubes 5200. Thus, the tanks 5300 are layed over the tubes 5200 viewed from the ejecting direction (Z axis direction.) As a result, the apparatus can be downsized both in the scanning direction (X axis direction) and in the transfer direction (Y axis direction.)

The tanks 5300 are disposed in the vicinity of the carriage 3100, therefore, the length of the flow path of the tube 5200 can be shorter, and the ink can be supplied in a stable manner.

The present invention is not limited to the 10th and 11th embodiments, and various modifications are available. To be more specific, in the 10th embodiment, the ink-supplying-tubes 5200 are coupled to the carriage 3100 at the side distant from the tanks 5300 in the transfer direction. However, the coupling section is not limited to this.

In the 11th embodiment, the tanks 5300 are placed on the upstream side of the tubes 5200 in the ejecting direction. However, the tanks 5300 can be placed on the downstream side of the tubes 5200.

Further in the 11th embodiment, the tubes 5200 are placed on the second side of the scanning direction from the first side thereof on the carriage 3100. However, the tubes 5200 can be placed a little bit outside from the end of the first side of the scanning direction on the carriage 3100.

Still further, in the 10th and 11th embodiments, sub-tanks can be provided to the carriage 3100 for temporary pooling of the inks supplied from the tanks 5300, the sub-tanks may be placed between the tanks 5300 and the heads 1000.

As discussed above, according to the apparatuses described in the 10th and 11th embodiments, the ink-supplying-tubes are routed through the carriage moving space, therefore, no additional space is specifically required for the tubes. As a result, the apparatus can be downsized.

The tubes are routed so that the flow-path length can be shorter and flow-path resistance against the ink can be lowered. As a result, the ink can be supplied to the heads in a stable manner.

Further, the ink-supplying-tubes are bowed and placed at the place adjacent to the carriage moving space on the first side of the transfer direction. This structure allows the tubes to have a larger curvature diameter, which realizes stable ink supply to the heads. At the same time, the coupling section

of the tubes to the carriage is located on the carriage on the second side of the scanning direction from the first side thereof, so that the apparatus can be downsized particularly in the scanning direction.

What is claimed is:

1. An inkjet recording apparatus comprising:
a scanner including a carriage driving motor for reciprocating a carriage having a recording head in a scanning direction (X axis direction); and
a transfer machine including a transfer motor operable to generate a driving force, a driving force transfer member, and a transfer roller for transferring a recording medium in a transfer direction (Y axis direction) perpendicular to the scanning direction, the driving force transfer member transferring the driving force generated by the transfer motor to the transfer roller,
wherein the carriage driving motor and the transfer motor are located approximately at a same level in an ejecting direction (Z axis direction) perpendicular to the scanning and transfer directions, and the level is above a transfer path of the recording medium and the transfer roller.
2. The inkjet recording apparatus as defined in claim 1, wherein the carriage driving motor is located on a first side of the inkjet recording apparatus with respect to the scanning direction and adjacent to a carriage moving space where the carriage reciprocates, and the transfer motor is located on a second side of the inkjet recording apparatus with respect to the scanning direction opposite to the first side, and
wherein the inkjet recording apparatus further comprises at least one element located between the carriage driving motor and the transfer motor and on a same side of the carriage with respect to the transfer direction as the carriage driving motor and the transfer motor.
3. The inkjet recording apparatus as defined in claim 2, wherein the at least one element is an ink tank for holding ink to be supplied to the recording head.

4. The inkjet recording apparatus as defined in claim 2, wherein the at least one element is a power supply for powering at least one of the scanner and the transfer machine.

5. The inkjet recording apparatus as defined in claim 2, wherein the at least one element is a controller for controlling at least one of the scanner and the transfer machine.

6. The inkjet recording apparatus as defined in claim 2, wherein the at least one element is a feeder for feeding the recording medium to the transfer machine.

7. The inkjet recording apparatus as defined in claim 1, further comprising:

a first ink-tank located on the carriage and for holding ink to be supplied to the recording head; and

a second ink-tank communicating with the first ink-tank, wherein said first ink-tank reciprocates with the carriage in a carriage moving space, and

wherein the carriage driving motor is located on a first side of the inkjet recording apparatus in the scanning direction and adjacent to the carriage moving space, and the transfer motor is located on a second side of the inkjet recording apparatus in the scanning direction opposite to the first side and adjacent to the carriage moving space.

8. The inkjet recording apparatus as defined in claim 1, wherein the driving force transfer member comprises at least one gear for transferring the driving force from the transfer motor to the transfer roller.

9. The inkjet recording apparatus as defined in claim 1, wherein the driving force transfer member transfers the driving force generated by the transfer motor to the transfer roller in a direction along the transfer path of the recording medium.

* * * * *