



US007272620B1

(12) **United States Patent**
Molnar et al.

(10) **Patent No.:** **US 7,272,620 B1**
(45) **Date of Patent:** **Sep. 18, 2007**

(54) **FREQUENCY DIVIDER WITH LOW HARMONICS**

(75) Inventors: **Alyosha C. Molnar**, Costa Mesa, CA (US); **Rahul Magoon**, Irvine, CA (US)

(73) Assignee: **Skyworks Solutions, Inc.**, Irvine, CA (US)

(*) Notice: Subject to any disclaimer, the term of this patent is extended or adjusted under 35 U.S.C. 154(b) by 573 days.

| | | | |
|-----------------|---------|-----------------|---------|
| 5,206,539 A | 4/1993 | Kammeter | |
| 5,343,080 A | 8/1994 | Kammeter | |
| 5,425,074 A * | 6/1995 | Wong | 377/47 |
| 5,434,455 A | 7/1995 | Kammeter | |
| 5,557,649 A | 9/1996 | Scheckel et al. | |
| 5,594,735 A | 1/1997 | Jokura | |
| 5,614,869 A * | 3/1997 | Bland | 331/1 A |
| 5,841,302 A | 11/1998 | Ishii et al. | |
| 5,859,890 A | 1/1999 | Shurboff et al. | |
| 5,867,068 A * | 2/1999 | Keating | 331/1 A |
| 6,163,181 A * | 12/2000 | Nishiyama | 327/115 |
| 6,356,123 B1 * | 3/2002 | Lee et al. | 708/103 |
| 2004/0160247 A1 | 8/2004 | Magoon et al. | |

(21) Appl. No.: **09/821,833**

(22) Filed: **Mar. 30, 2001**

Related U.S. Application Data

(63) Continuation-in-part of application No. 09/370,099, filed on Aug. 6, 1999, now Pat. No. 6,707,326.

(51) **Int. Cl.**
G06F 7/52 (2006.01)

(52) **U.S. Cl.** **708/103**

(58) **Field of Classification Search** 708/103,
708/270-277; 327/115, 113, 114, 117; 377/47,
377/48

See application file for complete search history.

(56) **References Cited**

U.S. PATENT DOCUMENTS

| | | | |
|---------------|---------|-------------|---------|
| 4,204,264 A | 5/1980 | Lipman | |
| 4,531,098 A | 7/1985 | Reed | |
| 4,560,945 A | 12/1985 | Olver | |
| 4,606,059 A | 8/1986 | Oida | |
| 5,077,764 A | 12/1991 | Yamashita | |
| 5,144,254 A * | 9/1992 | Wilke | 327/107 |

* cited by examiner

Primary Examiner—Meng-Ai T. An

Assistant Examiner—Chat C. Do

(74) *Attorney, Agent, or Firm*—Thomas, Kayden, Horstemeyer & Risley, LLP

(57) **ABSTRACT**

A frequency divider has two or more storage elements connected in a loop. One of the outputs of each storage element is connected to one of the inputs of another storage element. Each storage element provides at least one output signal having a period equal to the period of a reference input signal multiplied by the number of interconnected storage elements. The reference input signal may be, for example, a local oscillator (“LO”) signal. In the case where the reference input signal has a 50% duty cycle, the output signals will also have a 50% duty cycle. Furthermore, in the case where a total of three storage elements are connected in a loop, the outputs of two of the three storage elements can be combined to provide a signal having substantially no third order harmonics.

31 Claims, 12 Drawing Sheets

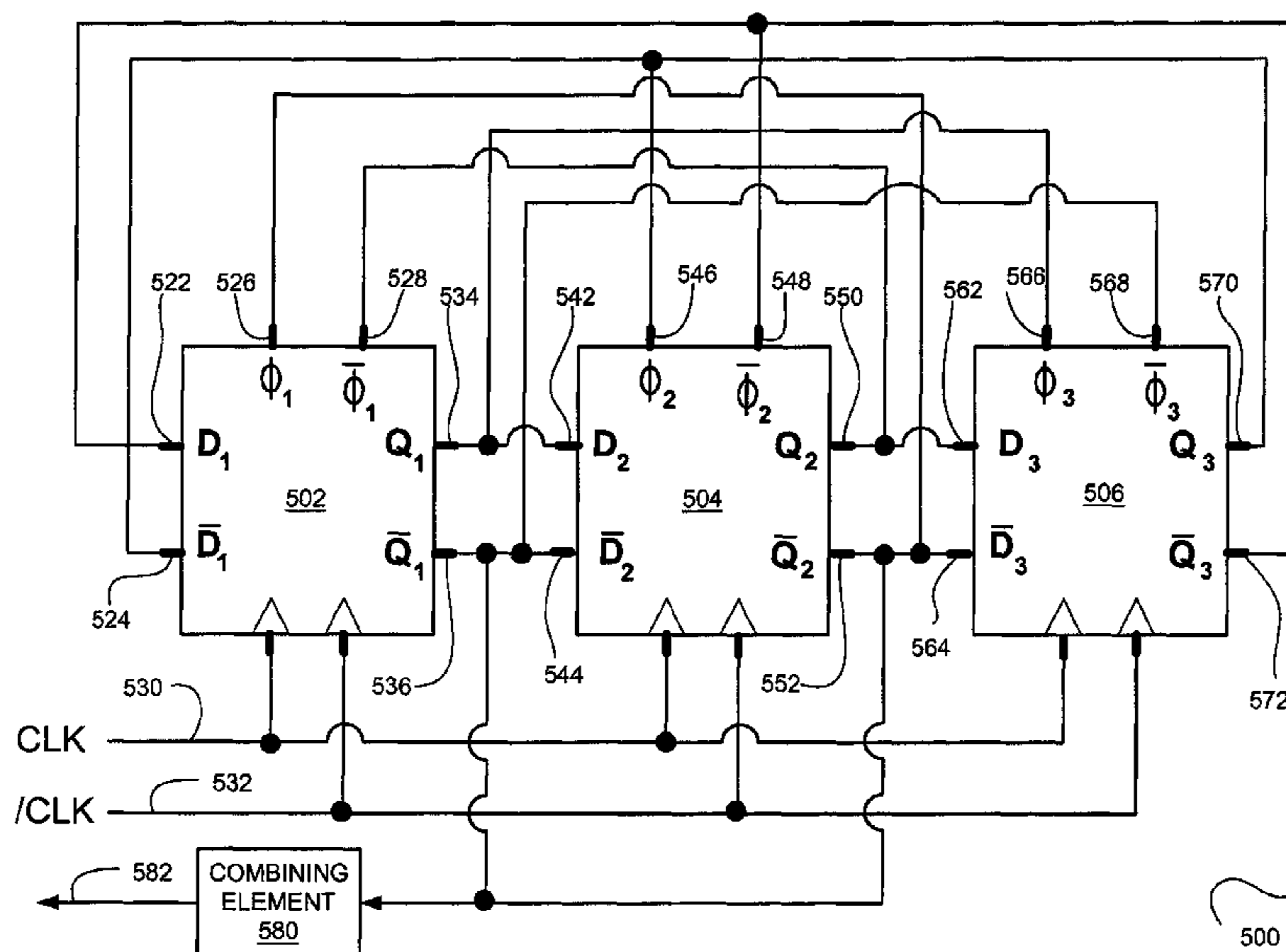

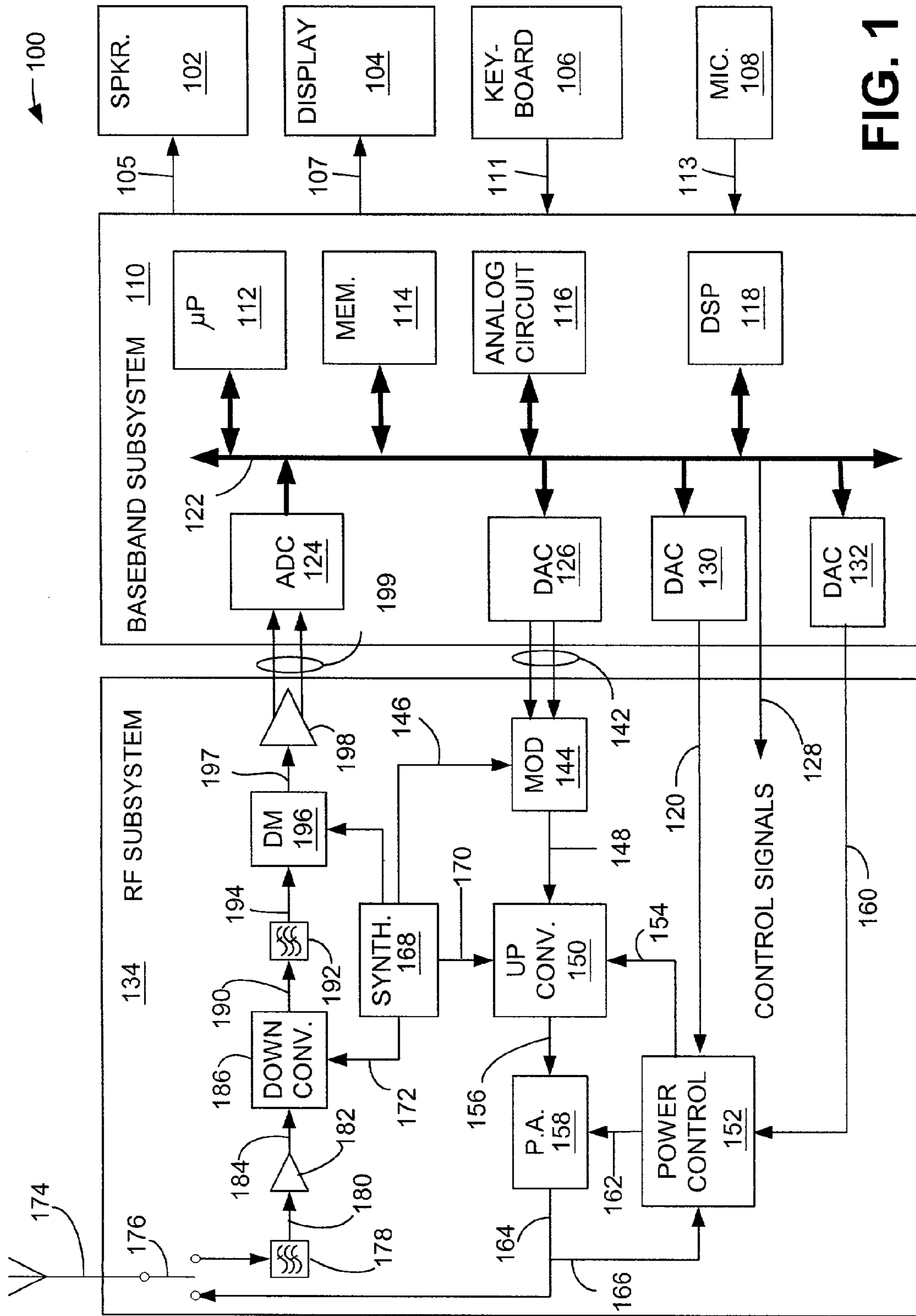

FIG. 1

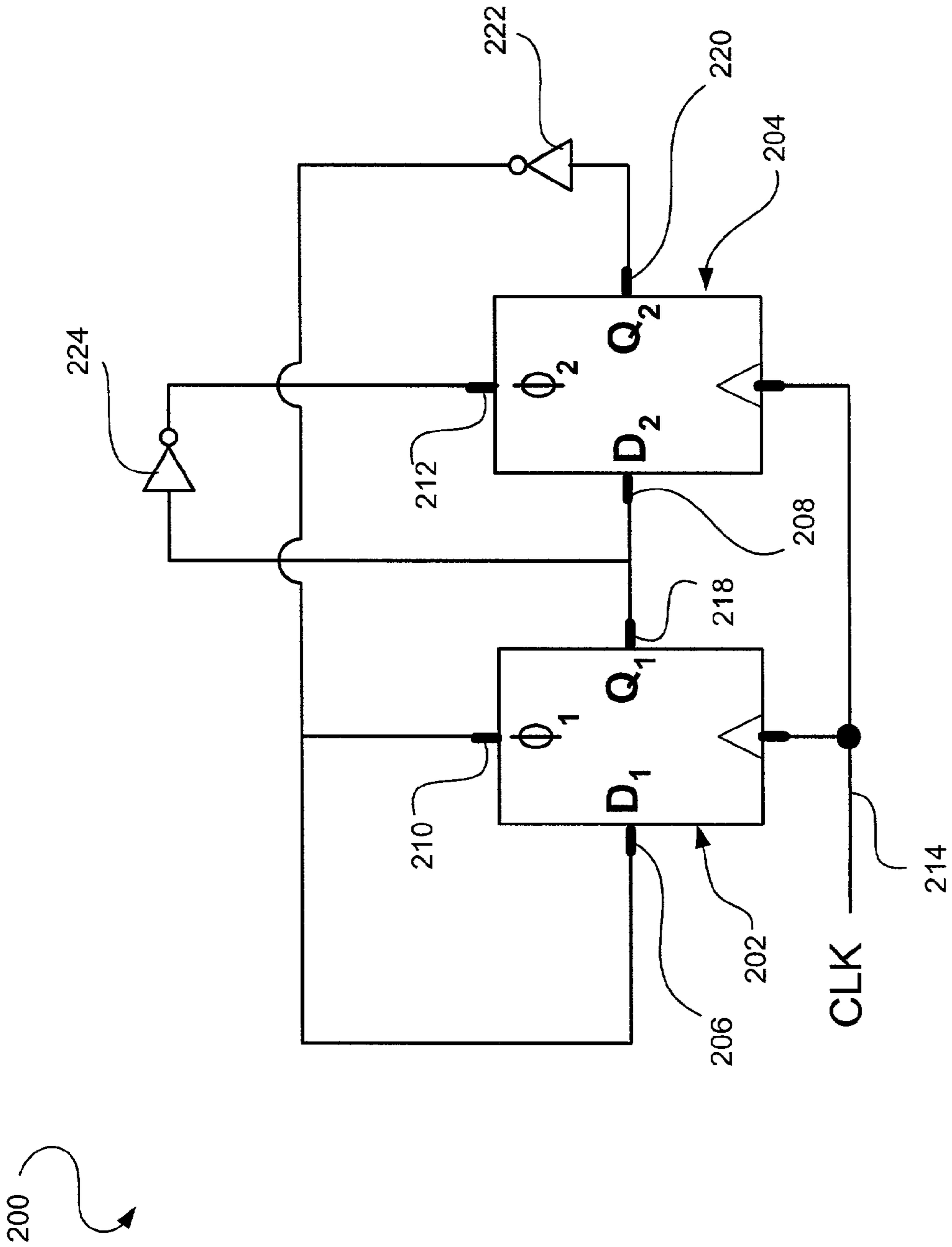

FIG. 2

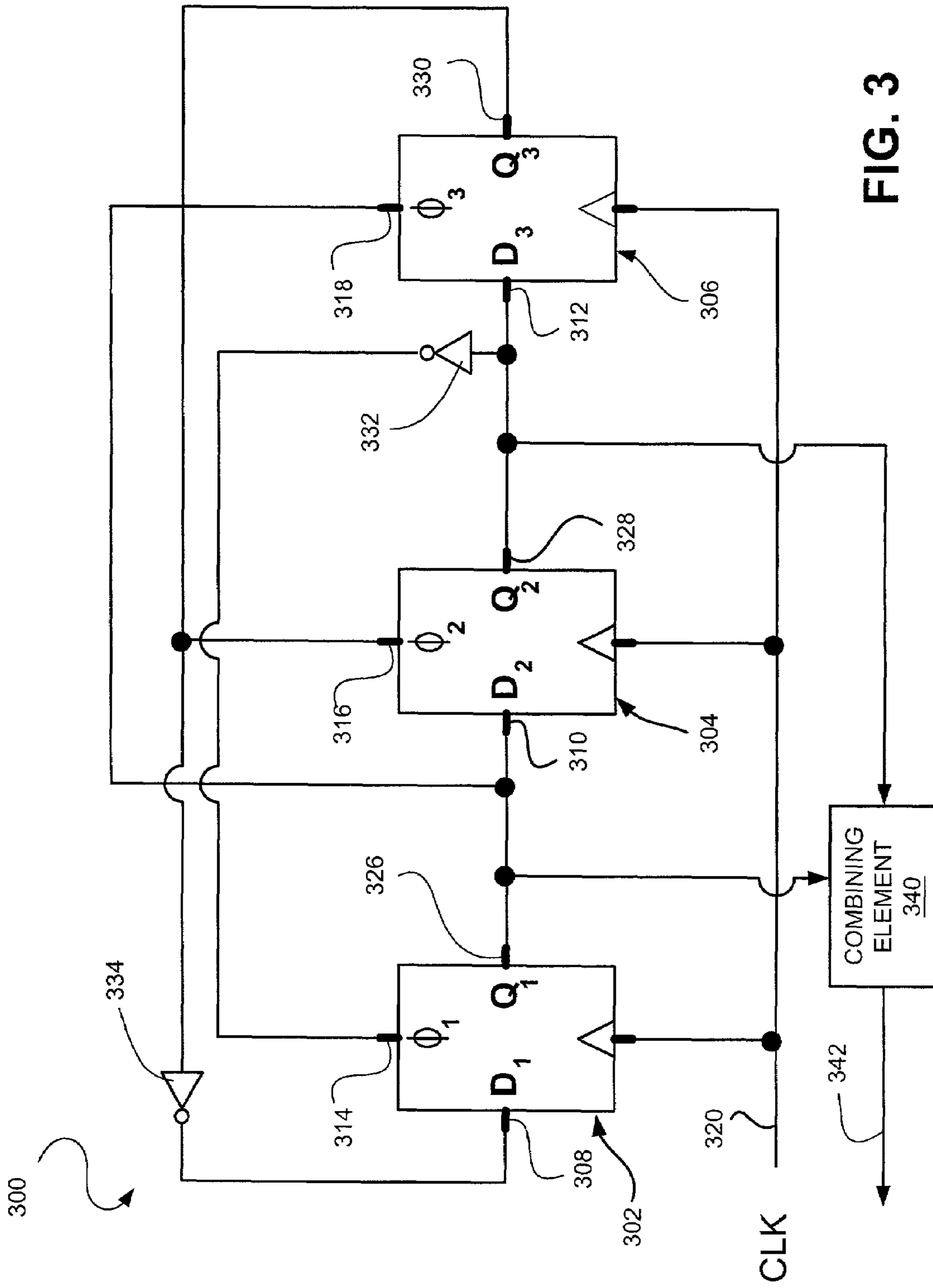

FIG. 3

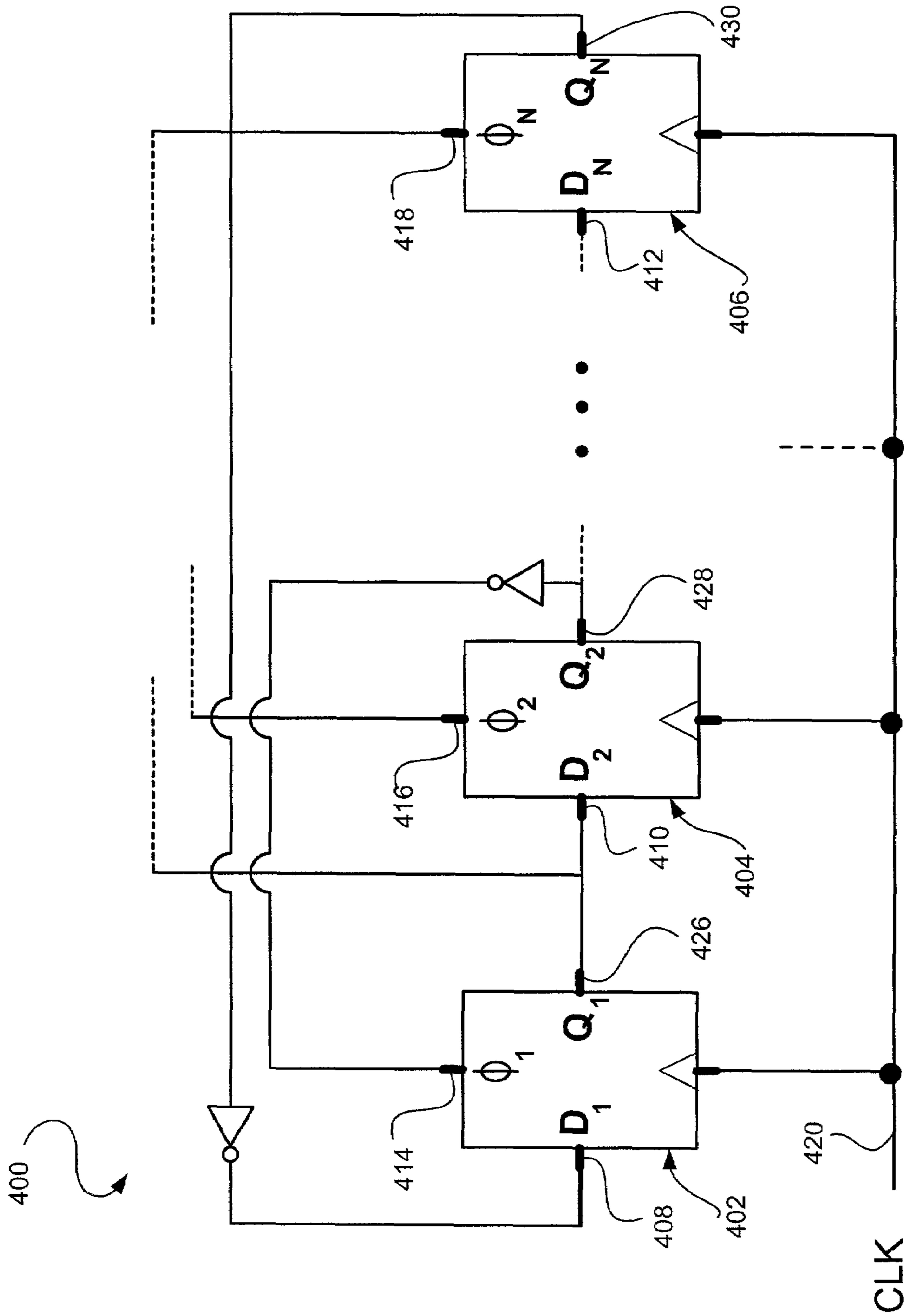

FIG. 4

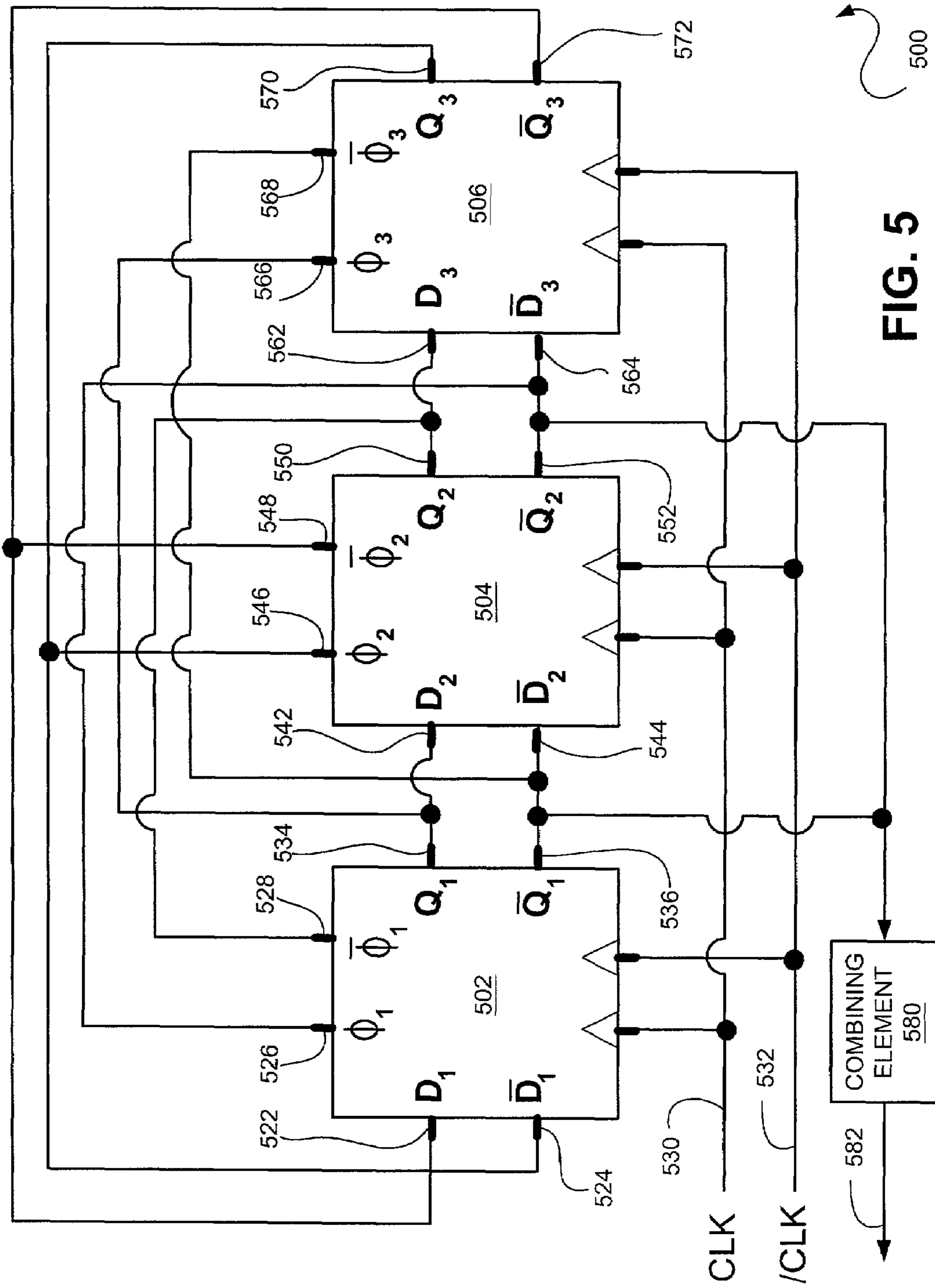

FIG. 5

600

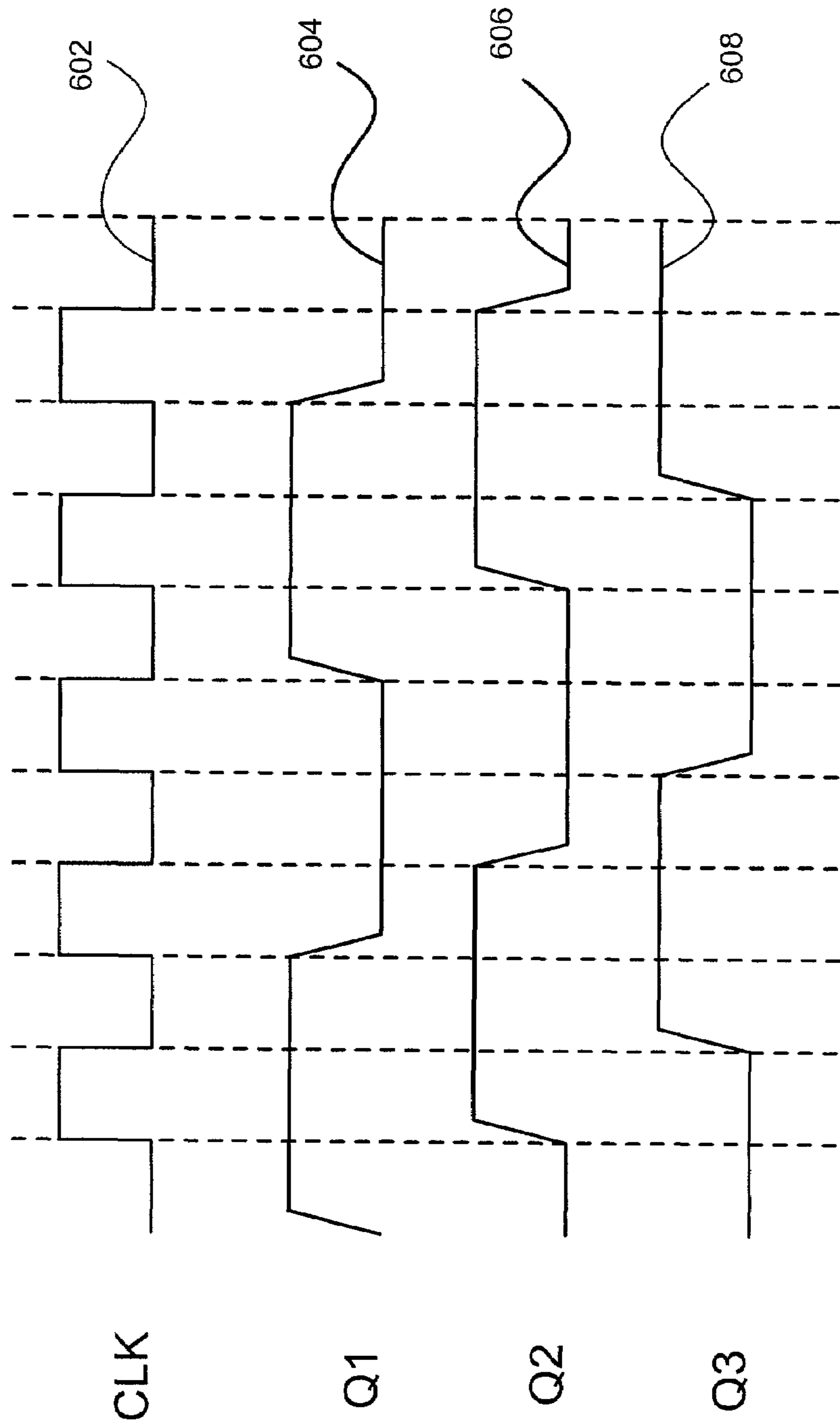

FIG. 6

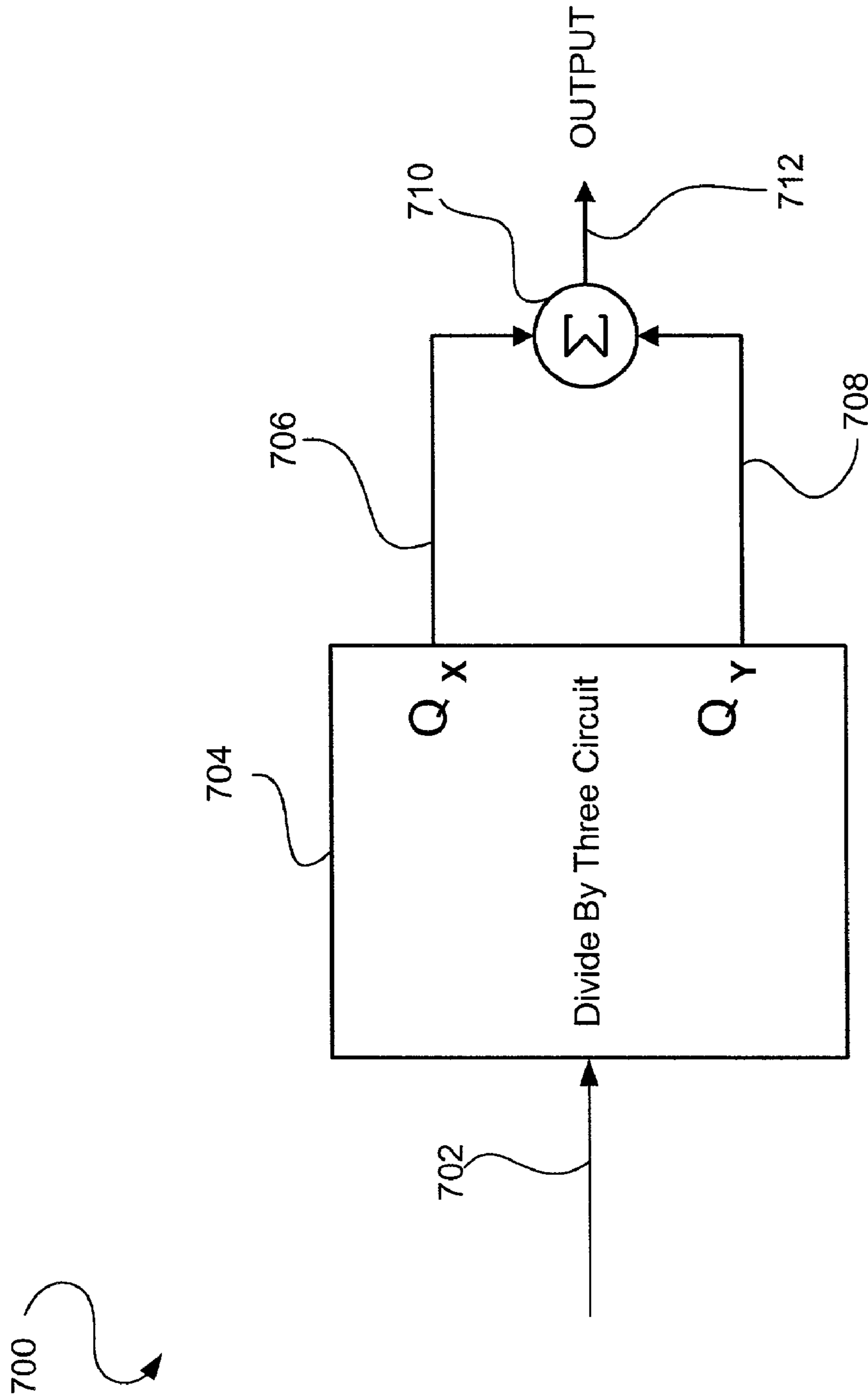

FIG. 7

800

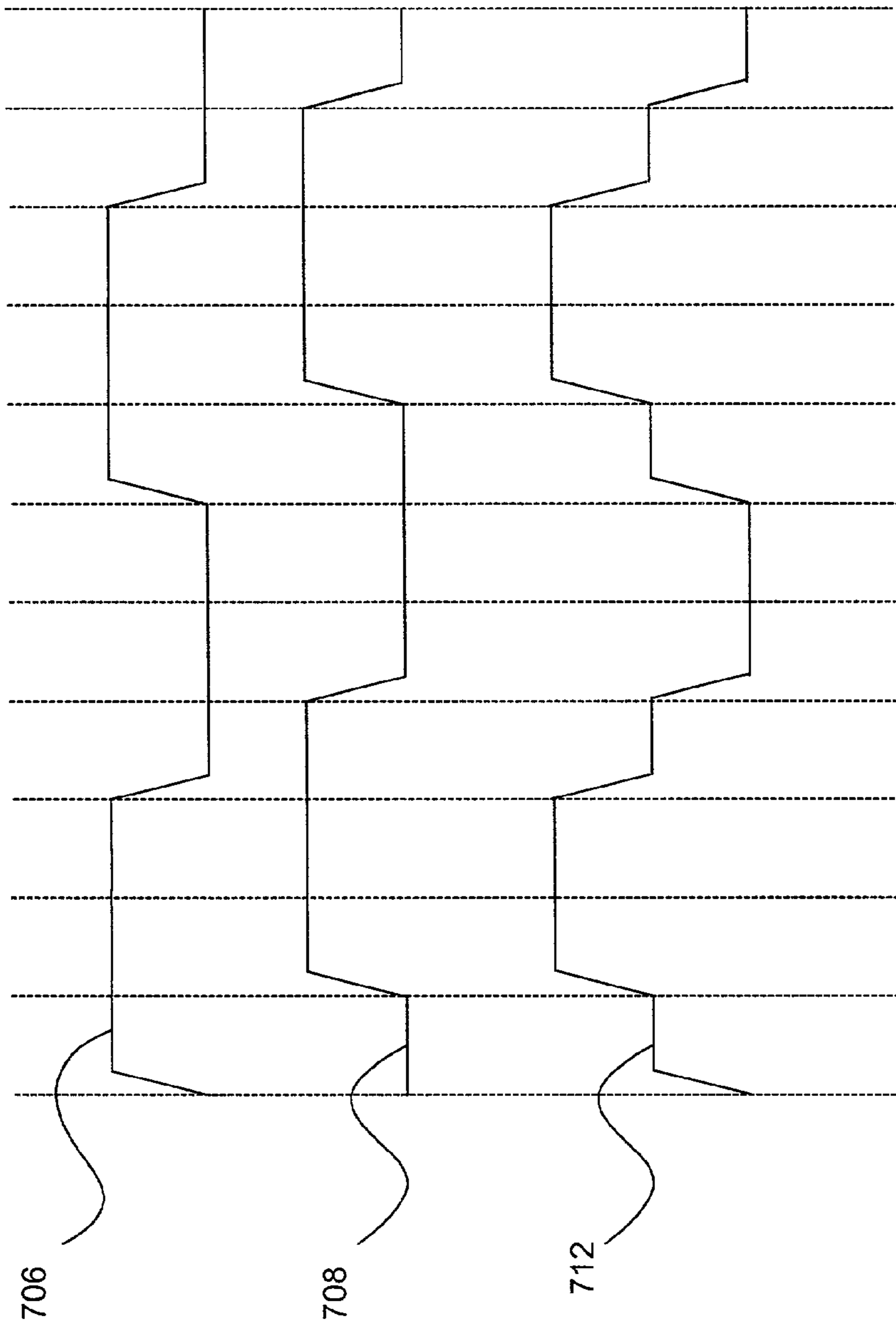

FIG. 8

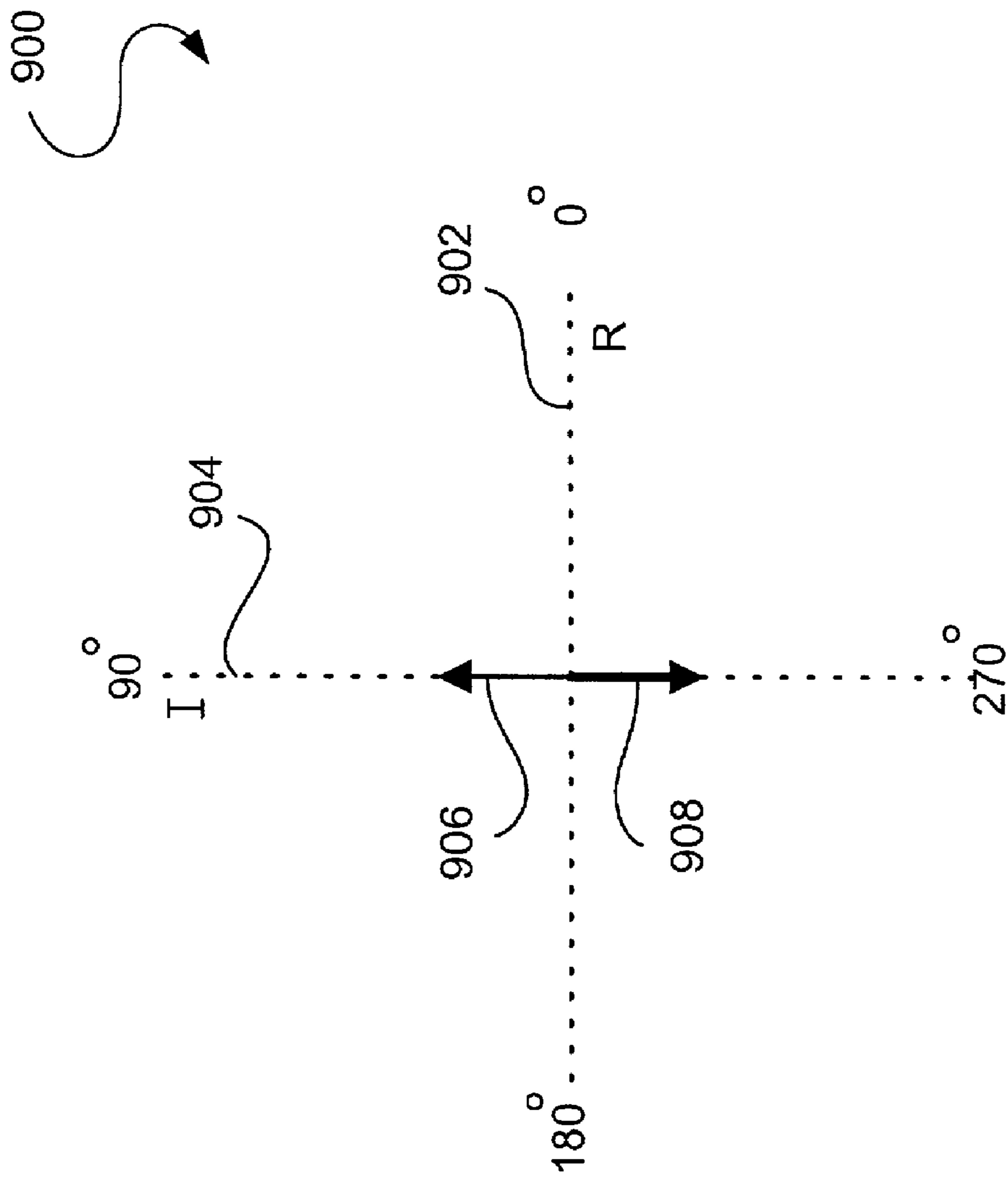

FIG. 9

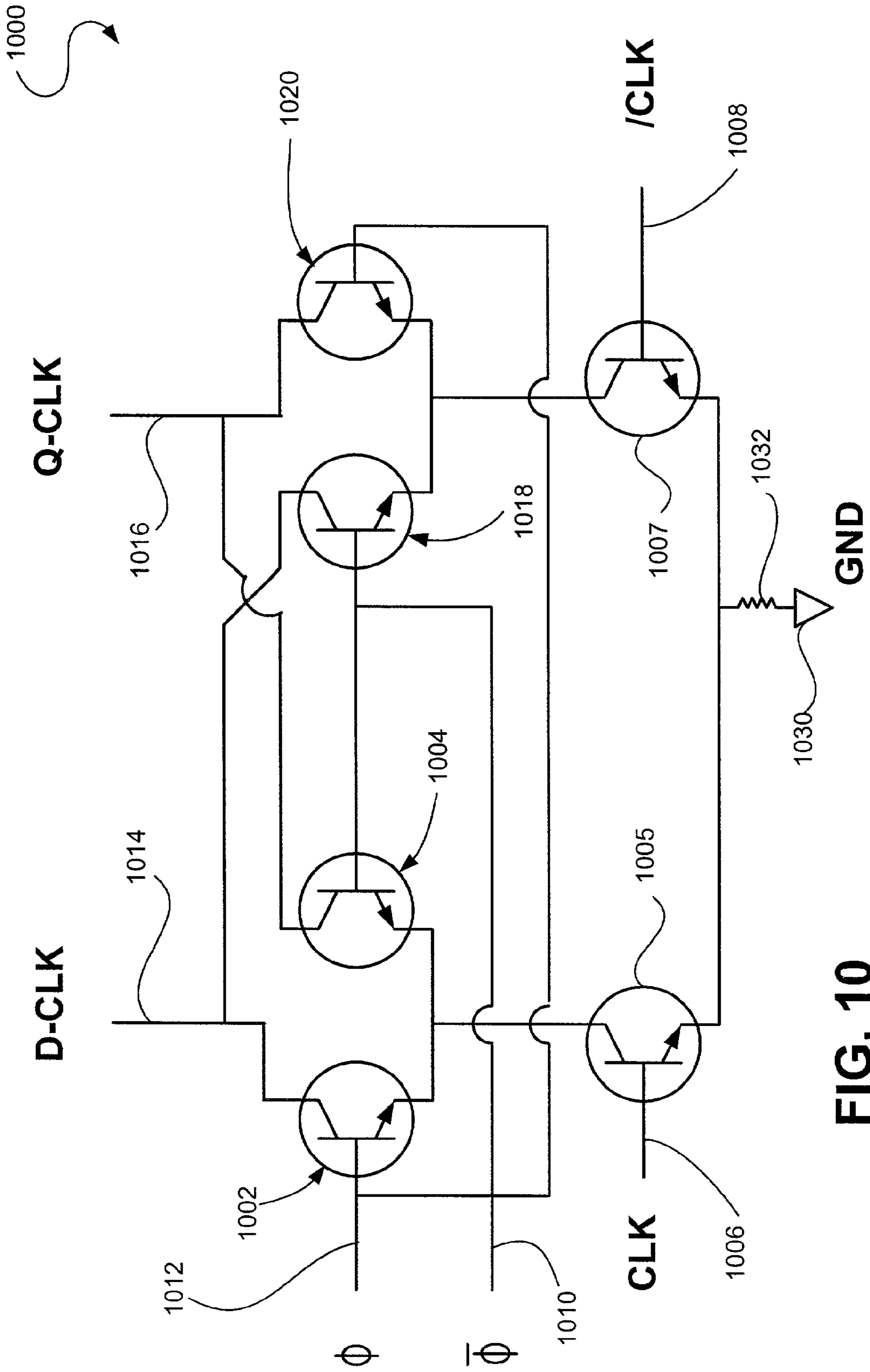

FIG. 10

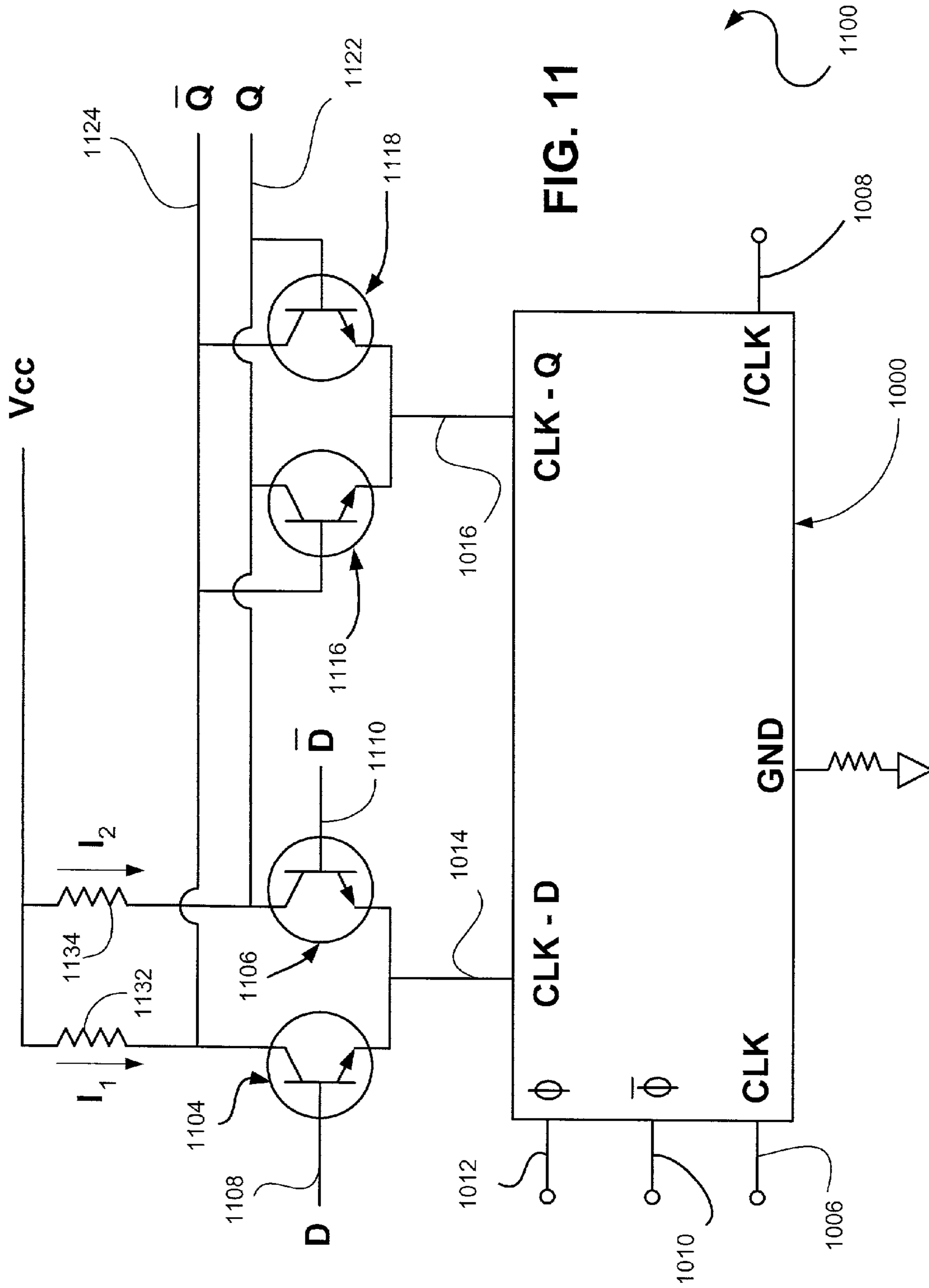

FIG. 11

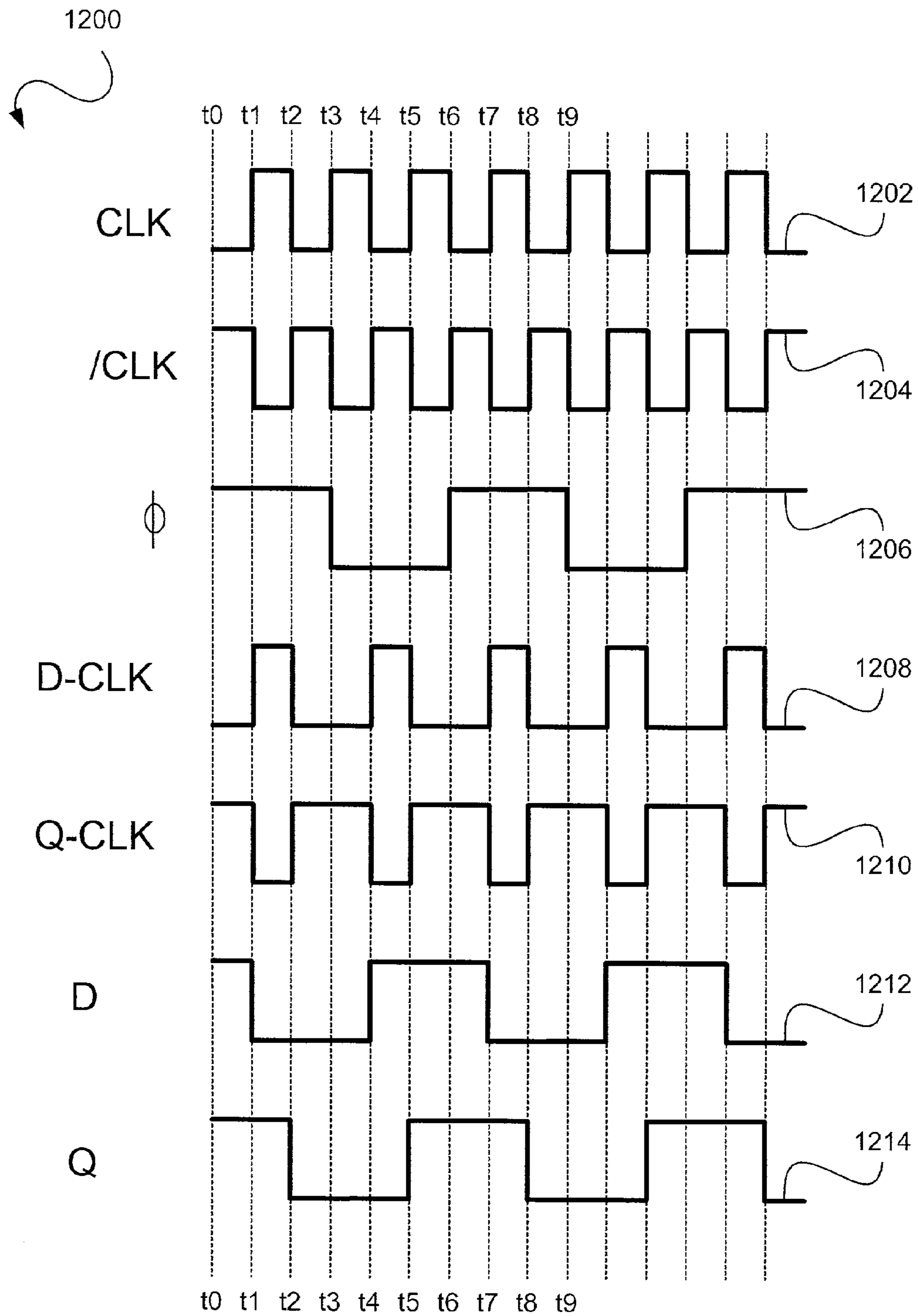

FIG. 12

FREQUENCY DIVIDER WITH LOW HARMONICS

BACKGROUND OF THE INVENTION

1. Claim of Priority

This application is a continuation-in-part of copending U.S. utility application entitled "Programmable Frequency Divider," Ser. No. 09/370,099, filed on Aug. 6, 1999, now U.S. Pat. No. 6,707,326 and is incorporated by reference in its entirety.

2. Field of the Invention

This invention relates to wireless transmitters and receivers and, more particularly, to frequency dividers.

3. Related Art

Harmonics contained in signal processing devices are a major cause of signal distortions. One case where harmonics can be especially problematic is in a limiter that is driven by a poly-phase filter. For example, standard 90° poly-phase outputs take the form of:

$$0^\circ \text{ output} = \text{input} / (1 + j\omega RC)$$

$$90^\circ \text{ output} = \text{input} * (j\omega RC) / (1 + j\omega RC)$$

Based on this property, harmonic components in the output will be amplitude mismatched and will be phase shifted from the fundamental frequency. Therefore, the presence of harmonics at the input of a poly-phase filter can cause a shift in the zero-crossings at the output of the poly-phase filter. This shift can, in turn, cause an effective phase error when the output of the poly-phase filter is passed through a limiter that reacts primarily to zero crossings.

A second case where harmonics can cause signal distortions is in mixers. The presence of harmonics in a mixer input signal can result in odd-order mixing products ("OMPs") in the mixer's output. An OMP, which is defined as the product of one input and an odd harmonic of another input, can cause signal distortions when its frequency is too close to the frequency of a desired mixer output signal. Other cases where harmonics can cause signal distortions include, for example, where unwanted harmonics couple across a circuit.

Therefore, there exists a need for signal processing systems that have reduced harmonic content.

SUMMARY

In one embodiment of the invention, a frequency divider has two or more storage elements connected in a loop. One of the outputs of each storage element is connected to one of the inputs of another storage element. Each storage element provides at least one output signal having a period equal to the period of a reference input signal multiplied by the number of interconnected storage elements. The reference input signal may be, for example, a local oscillator ("LO") signal. In the case where the reference input signal has a 50% duty cycle, the output signals will also have a 50% duty cycle.

In another embodiment of the invention, a signal processing system includes three storage elements connected in a loop. One of the outputs of each of the three storage elements is connected to one of the inputs of another one of the three storage elements. Each storage element provides at least one output signal having a frequency equal to a third of the frequency of the reference input signal. The outputs of two of the three storage elements are combined to provide a signal having substantially no third order harmonics.

Other systems, methods, features and advantages of the invention will be or will become apparent to one with skill in the art upon examination of the following figures and detailed description. It is intended that all such additional systems, methods, features and advantages be included within this description, be within the scope of the invention, and be protected by the accompanying claims.

BRIEF DESCRIPTION OF THE DRAWINGS

The components in the figures are not necessarily to scale, emphasis instead being placed upon illustrating the principles of the invention. In the figures, like reference numerals designate corresponding parts throughout the different views.

FIG. 1 is a block diagram illustrating a non-limiting example of a simplified portable transceiver.

FIG. 2 is a block diagram illustrating an embodiment of a "divide by two" frequency divider.

FIG. 3 is a block diagram illustrating an embodiment of a "divide by three" frequency divider.

FIG. 4 is a block diagram illustrating an embodiment of a "divide by N" frequency divider.

FIG. 5 is a block diagram illustrating an alternative embodiment of a "divide by three" frequency divider.

FIG. 6 is a timing diagram illustrating frequency.

FIG. 7 is a block diagram of a low harmonics frequency division system.

FIG. 8 is an example timing diagram illustrating the addition of frequency divider outputs.

FIG. 9 is a phase diagram illustrating a non-limiting example of third-order harmonics cancellation by the low harmonics frequency division system of FIG. 7.

FIG. 10 is a block diagram illustrating one possible configuration of a clock phase module that can be used in a storage element of the invention.

FIG. 11 is a block diagram illustrating one possible configuration of a storage element of the invention.

FIG. 12 is a simplified timing diagram illustrating the operation of storage element as part of a "divide by three" frequency divider.

DETAILED DESCRIPTION

FIG. 1 is a block diagram illustrating a non-limiting example of a simplified portable transceiver 100 in which an embodiment of the invention may be implemented. Portable transceiver 100 includes speaker 102, display 104, keyboard 106, and microphone 108, all connected to baseband subsystem 110. In a particular embodiment, portable transceiver 100 can be, for example, but not limited to, a portable telecommunication handset such as a mobile cellular-type telephone. Speaker 102 and display 104 receive signals from baseband subsystem 110 via connections 105 and 107, respectively. Similarly, keyboard 106 and microphone 108 supply signals to baseband subsystem 110 via connections 111 and 113, respectively. Baseband subsystem 110 includes microprocessor (μP) 112, memory 114, analog circuitry 116, and digital signal processor (DSP) 118, each coupled to a data bus 122. Examples of commercially available processors include, but are not limited to, an ARM processor such as an ARM 7 or ARM 9 processor, a ZSP Core supplied by LSI Logic or a Teak processor supplied by DSP Group. Data bus 122, although shown as a single bus, may be implemented using multiple busses connected as necessary among the subsystems within baseband subsystem 110. Microprocessor 112 and memory 114 provide signal timing, process-

ing and storage functions for portable transceiver 100. Analog circuitry 116 provides the analog processing functions for the signals within baseband subsystem 110. Baseband subsystem 110 provides control signals to radio frequency (RF) subsystem 134 via connection 128. Although shown as a single connection 128, the control signals may originate from DSP 118 or from microprocessor 112, and may be supplied to a variety of points within RF subsystem 134. It should be noted that, for simplicity, only selected components of a portable transceiver 100 are illustrated in FIG. 1.

Baseband subsystem 110 also includes analog-to-digital converter (ADC) 124 and digital-to-analog converters (DACs) 126, 130 and 132. ADC 124, DAC 126, DAC 130 and DAC 132 communicate with microprocessor 112, memory 114, analog circuitry 116 and DSP 118 via data bus 122. DAC 126 converts digital communication information within baseband subsystem 110 into an analog signal for transmission to RF subsystem 134 via connection 142. In accordance with an aspect of the invention, DAC 130 provides a reference voltage power level signal to power control element 152 via connection 120 and DAC 132 provides an amplitude modulated (AM) signal to power control element 152 via connection 160. Alternatively, circuitry (not shown) could be placed in power control element 152 to derive the AM signal based on the output of DAC 126 received via connection 142. Connection 142, while shown as two directed arrows, includes the information that is to be transmitted by RF subsystem 134 after conversion from the digital domain to the analog domain.

RF subsystem 134 includes modulator 144, which, after receiving an LO signal from synthesizer 168 via connection 146, modulates the received analog information and provides a modulated signal via connection 148 to upconverter 150. Upconverter 150 also receives a frequency reference signal from synthesizer 168 via connection 170. Synthesizer 168 determines the appropriate frequency to which upconverter 150 will upconvert the modulated signal on connection 148.

Upconverter 150 supplies a phase-modulated signal via connection 156 to power amplifier 158. Power amplifier 158 amplifies the modulated signal on connection 156 to the appropriate power level for transmission via connection 164 to antenna 174. Illustratively, switch 176 controls whether the amplified signal on connection 164 is transferred to antenna 174 or whether a received signal from antenna 174 is supplied to filter 178. The operation of switch 176 is controlled by a control signal from baseband subsystem 110 via connection 128. Alternatively, the switch 176 may be replaced with circuitry to enable the simultaneous transmission and reception of signals to and from antenna 174.

A portion of the amplified transmit signal energy on connection 164 is supplied via connection 166 to power control element 152. Power control element 152 forms a closed power control feedback loop and supplies an AM component of the transmit signal via connection 162 to power amplifier 158 and also supplies a power control feedback signal via connection 154 to upconverter 150.

A signal received by antenna 174 will, at the appropriate time determined by baseband system 110, be directed via switch 176 to a receive filter 178. Receive filter 178 filters the received signal and supplies the filtered signal on connection 180 to low noise amplifier (LNA) 182. Receive filter 178 is a bandpass filter, which passes all channels of the particular cellular system in which the portable transceiver 100 is operating. As an example, for a Global System For Mobile Communications (GSM) 900 MHz system, receive

filter 178 would pass all frequencies from 935.1 MHz to 959.9 MHz, covering all 124 contiguous channels of 200 kHz each. The purpose of this filter is to reject all frequencies outside the desired region. LNA 182 amplifies the weak signal on connection 180 to a level at which downconverter 186 can translate the signal from the transmitted frequency back to a baseband frequency. Alternatively, the functionality of LNA 182 and downconverter 186 can be accomplished using other elements, such as for example but not limited to, a low noise block downconverter (LNB).

Downconverter 186 receives an LO signal from synthesizer 168, via connection 172. The LO signal is used in the downconverter 186 to downconvert the signal received from LNA 182 via connection 184. The downconverted frequency is called the intermediate frequency ("IF"). Downconverter 186 sends the downconverted signal via connection 190 to channel filter 192, also called the "IF filter." Channel filter 192 filters the downconverted signal and supplies it via connection 194 to demodulator 196. The channel filter 192 selects one desired channel and rejects all others. Using the GSM system as an example, only one of the 124 contiguous channels would be selected by channel filter 192. The synthesizer 168, by controlling the local oscillator frequency supplied on connection 172 to downconverter 186, determines the selected channel. Demodulator 196 recovers the transmitted analog information and supplies a signal representing this information via connection 197 to amplifier 198. Amplifier 198 amplifies the signal received via connection 197 and supplies an amplified signal via connection 199 to ADC 124. ADC 124 converts these analog signals to a digital signal at baseband frequency and transfers it via data bus 122 to DSP 118 for further processing. Although, for illustration purposes, the invention is described below with respect to portable transceiver 100, it should be noted that the invention may also be implemented in any wireless communication system that uses one or more mixers.

FIG. 2 is a block diagram illustrating an embodiment of a "divide by two" frequency divider 200 of the invention. The frequency divider 200 includes two storage elements 202 and 204. Storage elements 202 and 204 are configured to receive inputs D_1 206 and D_2 208 respectively, inputs ϕ_1 210 and ϕ_2 212 respectively, and a reference signal input ("CLK") 214. In one embodiment, CLK 214 is an LO signal. The storage elements 202 and 204 also provide outputs Q_1 218 and Q_2 220 and respectively. The frequency of each of the outputs Q_1 218 and Q_2 220 is equal to half of the frequency of CLK 214.

The storage elements 202 and 204 are interconnected as follows: Q_1 218 is connected to D_2 208, Q_2 220 is connected through inverter 222 to D_1 206 and ϕ_1 210, and Q_1 218 is connected through inverter 224 to ϕ_2 212. Furthermore, in some embodiments, the relationships between the inputs and outputs of each of the storage elements 202 and 204 are defined in Table 1.

TABLE 1

| Truth Table For A Frequency Divider Storage Element | | | | |
|---|------|------|--------|----------|
| CLK(t) | D(t) | Q(t) | Phi(t) | Q(t + 1) |
| 0 | 0 | 0 | 0 | 0 |
| 0 | 0 | 0 | 1 | 0 |
| 0 | 0 | 1 | 0 | 0 |
| 0 | 0 | 1 | 1 | 1 |
| 0 | 1 | 0 | 0 | 1 |
| 0 | 1 | 0 | 1 | 0 |
| 0 | 1 | 1 | 0 | 1 |

TABLE 1-continued

| Truth Table For A Frequency Divider Storage Element | | | | |
|---|------|------|--------|----------|
| CLK(t) | D(t) | Q(t) | Phi(t) | Q(t + 1) |
| 0 | 1 | 1 | 1 | 1 |
| 1 | 0 | 0 | 0 | 0 |
| 1 | 0 | 0 | 1 | 0 |
| 1 | 0 | 1 | 0 | 1 |
| 1 | 0 | 1 | 1 | 0 |
| 1 | 1 | 0 | 0 | 0 |
| 1 | 1 | 0 | 1 | 1 |
| 1 | 1 | 1 | 0 | 1 |
| 1 | 1 | 1 | 1 | 1 |

The states “1” and “0” in Table 1 are commonly referred to as “high” and “low” states, respectively, and are typically represented by distinguishable voltage levels such as, for example, “positive” and “negative” voltages, or “higher” and “lower” voltages. The relationships between the inputs and outputs of each of the storage elements **202** and **204** may also be described by the following logic equation:

$$Q_{N+1} = D / (\phi / \text{CLK} + \phi \text{CLK}) + Q_N / (\phi / \text{CLK} + \phi \text{CLK})$$

(where a slash (“/”) means “inverse of” such that $1/\phi$, for example, is the inverse of ϕ , and where the subscript “ N ” refers to a current state and the subscript “ $N+1$ ” refers to the state that is immediately following the current state).

FIG. 3 is a block diagram illustrating an embodiment of a “divide by three” frequency divider **300** of the invention. The frequency divider **300** includes three storage elements **302**, **304** and **306**. Storage element **302** is configured to receive inputs D_1 **308**, ϕ_1 **314**, and CLK **320** and to provide output Q_1 **326**. Storage element **304** is configured to receive inputs D_2 **310**, ϕ_2 **316**, and CLK **320**, and to provide output Q_2 **328**. Storage element **306** is configured to receive inputs D_3 **312**, ϕ_3 **318**, and CLK **320**, and to provide output Q_3 **330**. Storage elements **302**, **304**, and **306** are interconnected as follows: Q_1 **326** is connected to D_2 **310** and ϕ_3 **318**, Q_3 **330** is connected via inverter **334** to D_1 **308**, Q_2 **328** is connected to D_3 **312**, and Q_2 **328** is connected via inverter **332** to ϕ_1 **314**. Furthermore, in one implementation, storage elements **302**, **304**, and **306** are configured to behave in accordance with the logic relationships shown in Table 1 above.

The frequency of each of the outputs Q_1 **326**, Q_2 **328**, and Q_3 **330**, has a frequency equal to one third of the frequency of the clock signal input. Two of the outputs Q_1 **326**, Q_2 **328**, and Q_3 **330** may be combined to produce a system output having substantially no third-order harmonics, as will be explained further below. In the example shown in FIG. 3, Q_1 **326** and Q_2 **328** are combined via combining element **340** to produce low harmonics output **342**. Combining element **340** may be, for example, a combiner, an adder, or merely a node that sums currents.

FIG. 4 is a block diagram illustrating an embodiment of a “divide by N” frequency divider **400** of the invention. The frequency divider **400** includes N storage elements including a first storage element **402**, a second storage element **404**, an N^{th} storage element **406**, and one or more additional storage elements (not shown). Storage element **402** is configured to receive inputs D_1 **408**, ϕ_1 **414**, and CLK **420** and to provide output Q_1 **426**. Storage element **404** is configured to receive inputs D_2 **410**, ϕ_2 **416**, and CLK **420**, and to provide output Q_2 **428**. Storage element **406** is configured to receive inputs D_N **412**, ϕ_N **418**, and CLK **420**, and to provide output Q_N **430**. Each of the output signals Q_1 **426**, Q_2 **428**, and Q_N **430**, has a frequency equal to the frequency of the clock signal

input divided by the number of interconnected storage elements N. Storage elements **402**, **404**, and **406** are interconnected as follows:

- Q_k is connected to D_{k-1}
- Q_1 is connected to D_N
- D_k is connected to Q_{k-1} for $k=2$ to N
- ϕ_k is connected to $1/Q_{k-1}$ for odd k less than N
- ϕ_k is connected to Q_{k+1} for even k less than N
- ϕ_N is connected to Q_1 for N=odd integer
- ϕ_N is connected to $1/Q_1$ for N=even integer

(where k is an integer assigned to a storage element based on its location in the sequence of N storage elements). In one implementation, storage elements **402**, **404**, and **406** are configured to behave in accordance with the logic relationships shown in Table 1. Note that since the storage elements are effectively connected in a loop, all connection specifications for even numbered elements and odd numbered elements can be interchanged without a loss in functionality.

FIG. 5 is a block diagram illustrating an alternative embodiment of a “divide by three” frequency divider of the invention. Frequency divider **500** includes three storage elements **502**, **504** and **506** that are configured as follows: storage element **502** is configured to receive inputs D_1 **522**, $1/D_1$ **524**, ϕ_1 **526**, $1/\phi_1$ **528**, CLK **530**, and $1/\text{CLK}$ **532**, and to provide outputs Q_1 **534** and $1/Q_1$ **536**; storage element **504** is configured to receive inputs D_2 **542**, $1/D_2$ **544**, ϕ_2 **546**, $1/\phi_2$ **548**, CLK **530**, and $1/\text{CLK}$ **532**, and to provide outputs Q_2 **550** and $1/Q_2$ **552**; and storage element **506** is configured to receive inputs D_3 **562**, $1/D_3$ **564**, ϕ_3 **566**, $1/\phi_3$ **568**, CLK **530**, and $1/\text{CLK}$ **532**, and to provide outputs Q_3 **570** and $1/Q_3$ **572**.

Storage elements **502**, **504**, and **506** are interconnected as follows: Q_1 **534** is connected to D_2 **542** and ϕ_3 **566**, $1/Q_3$ **572** is connected to D_1 **522** and to $1/\phi_2$ **548**, Q_2 **550** is connected to D_3 **562** and $1/\phi_1$ **528**, $1/Q_1$ **536** is connected to $1/D_2$ **544** and $1/\phi_3$ **568**, Q_3 **570** is connected to $1/D_1$ **524** and ϕ_2 **546**, and $1/Q_2$ **552** is connected to $1/D_3$ **564** and ϕ_1 **526**. In one implementation, storage elements **502**, **504**, and **506** are configured to behave in accordance with the logic properties shown in Table 1.

The frequency of each of the outputs signals Q_1 **534**, Q_2 **550**, Q_3 **570**, $1/Q_1$ **536**, $1/Q_2$ **552**, and $1/Q_3$ **572**, has a frequency equal to one third of the frequency of CLK **530**. In one implementation, two of the outputs Q_1 **534**, Q_2 **550**, Q_3 **570**, $1/Q_1$ **536**, $1/Q_2$ **552**, and $1/Q_3$ **572** may be combined to produce a system output having substantially no third-order harmonics, as will be explained further below. In the example shown in FIG. 5, $1/Q_1$ **536** and $1/Q_2$ **552** are combined via combining element **580** to produce low harmonics output **582**. Combining element **580** may be, for example, a combiner, an adder, or merely a node that sums currents.

Each of the frequency dividers described above may be implemented in any radio frequency (RF) transmitter or receiver that uses frequency division. As a non-limiting example, a frequency divider of the invention may be used in synthesizer **168**, modulator **144**, demodulator **196**, upconverter **150**, and/or downconverter **186** (FIG. 1).

FIG. 6 is a timing diagram **600** illustrating frequency division of an embodiment of the invention, such as, for example, frequency divider **500** (FIG. 5), or frequency divider **300** (FIG. 3). The timing diagram illustrates four signals: an input reference signal **602**, a first storage element output (Q_1) **604**, a second storage element output (Q_2) **606**, and a third storage element output (Q_3) **608**. Outputs Q_1 **604**, Q_2 **606**, and Q_3 **608** may correspond, for example, to storage element outputs Q_1 **326**, Q_2 **328** and Q_3 **330**, respectively (FIG. 3) while the input reference signal **602** may corre-

spend, for example, to CLK 320 (FIG. 3). Each of the outputs (Q_1 604, Q_2 606, and Q_3 608) has a frequency equal to one third of the frequency of the input reference signal 602. As shown in the timing diagram 600, Q_2 606 lags Q_1 604 by $\frac{1}{6}$ of a cycle and Q_3 608 lags Q_2 606 by $\frac{1}{6}$ of a cycle. It should be noted that, in this example, each of the outputs has a 50% duty cycle. In general, however, the duty cycle of an output signal will be equal to about 33% plus $\frac{1}{3}$ of the duty cycle of an input signal.

FIG. 7 is a block diagram of a low harmonics frequency division system 700. The low harmonics frequency division system 700 includes a "divide by three" circuit 704. The "divide by three" circuit 704 may correspond, for example, to frequency divider 500 (FIG. 5), or frequency divider 300 (FIG. 3). The divide by three circuit 704 receives an input 702 and produces signals Q_x 706, Q_y 708, and Q_z (not shown). Q_x 706 and Q_y 708 are then combined at combining element 710 to provide a system output 712 having substantially no third-order harmonics. Combining element 710 may be a combiner, an adder, or merely a node that sums Q_x 706 and Q_y 708.

If, for example, the divide by three circuit used is frequency divider 500 (FIG. 5), then Q_x 706 and Q_y 708 may correspond, for example, to one of the following pairs of storage element outputs: Q_1 534 & Q_2 550, $/Q_1$ 536 & $/Q_2$ 552, Q_2 550 & Q_3 570, or $/Q_2$ 552 & $/Q_3$ 572. If, on the other hand, the divide by three circuit used is frequency divider 300 (FIG. 3), then Q_x 706 and Q_y 708 may correspond, for example, to storage element output pairs Q_1 326 & Q_2 328, or Q_2 328 & Q_3 330.

FIG. 8 is an example timing diagram 800 illustrating the addition of Q_x 706 and Q_y 708 shown in FIG. 7 to produce system output 712. In this example, Q_y 708 lags Q_x 706 by $\frac{1}{6}$ of a cycle. As shown in timing diagram 800, system output 712 is a step-shaped signal that has the same frequency as Q_x 706 and Q_y 708. Furthermore, although not readily apparent from diagram 800, system output 712 contains substantially no third-order harmonics.

Since Q_y 708 lags Q_x 706 by $\frac{1}{6}$ of a cycle (or 60°), each of the odd harmonics of output 708 will lag a corresponding odd harmonic of output 706 by "n" times 60° , where "n" is the harmonic number; for example, the third harmonic of Q_y 708 will lag the third harmonic of Q_x 706 by 180° . Therefore, by adding Q_x 706 and Q_y 708, the resulting system output 712 may have substantially no third-order harmonics.

FIG. 9 is a phase diagrams 900 illustrating a non-limiting example of third-order harmonics cancellation by low harmonics frequency division system 700. Phase diagram 900 includes a "real" axis 902 and an "imaginary" axis 904. Third harmonic components 906 and 908 are contained in signals 706 and 708, respectively (FIG. 7). Components 906 and 908 have the same magnitude but are 180° out of phase. Therefore, by combining signals 706 and 708, third harmonic components 906 and 908, respectively, can effectively cancel each other. Although, for illustration purposes, harmonic components 906 and 908 are shown to have phase angles of 90° and 270° , respectively, the phase angles may in fact have any respective values that are substantially 180° apart.

FIG. 10 is a block diagram illustrating one possible configuration of a clock phase module 1000. Two differential pairs of NPN bipolar transistors are provided. The first pair includes transistors 1002 and 1004, and the second pair includes transistors 1018 and 1020. The emitter of transistor 1002 is coupled to the emitter of transistor 1004, and the emitter of transistor 1018 is coupled to the emitter of transistor 1020. The emitters of transistors 1002 and 1004

are coupled to the collector of transistor 1005, and the emitters of transistors 1018 and 1020 are coupled to the collector of transistor 1007. A connection 1006 containing a first clock signal ("CLK") is connected to the base of transistor 1005, and a connection 1008 containing a second clock signal ("CLK") is connected to the base of transistor 1007 (where $/CLK$ is the inverse of CLK).

The bases of transistors 1002 and 1020 are coupled together and to a connection 1012 that contains an incoming signal ϕ . In addition, the bases of transistors 1004 and 1018 are coupled together and to a connection 1010 containing an incoming signal $/\phi$ (where $/\phi$ is the inverse of ϕ). The collectors of transistors 1002 and 1018 are coupled together, and to an output connection 1014 containing an output signal D-CLK. The collectors of transistors 1004 and 1020 are also coupled together, and to an output connection 1016 containing an output signal Q-CLK (where Q-CLK is the inverse D-CLK).

CLK and $/CLK$ represent a differential pair of input clock signals, ϕ and $/\phi$ represent a differential pair of phase control signals, and Q-CLK and D-CLK represent a differential pair of output clock signals. When ϕ is high and $/\phi$ is low, transistors 1002 and 1020 are active and transistors 1004 and 1018 are inactive. As a result, CLK is passed through transistors 1005 and 1002 to connection 1014 to form output clock signal D-CLK, and $/CLK$ is passed through transistors 1007 and 1020 to connection 1016 to form output Q-CLK. Conversely, when ϕ is low and $/\phi$ is high, transistors 1004 and 1018 are active and transistors 1002 and 1020 are inactive. As a result, CLK is passed through transistors 1005 and 1004 to connection 1016 to form output signal Q-CLK, and input $/CLK$ is passed through transistors 1007 and 1018 to connection 1014 to form output D-CLK.

FIG. 11 is a block diagram illustrating one possible configuration of a storage element 1100 of the invention. Storage element 1100 may correspond, for example, to each of the storage elements 502, 504, and 506 shown in FIG. 5. Storage element 1100 includes a first differential pair of NPN bipolar transistors 1104 and 1106, a second differential pair of NPN bipolar transistors 1116 and 1118, and a clock phase module 1000.

The emitters of transistors 1104 and 1106 are coupled together and to connection 1014 containing the clock phase module output D-CLK. The collector of transistor 1104 is connected to V_{cc} through resistor 1132, and the collector of transistor 1106 is connected to V_{cc} through resistor 1134. An input signal D, is provided to the base of transistor 1104 via connection 1108, and the an input signal $/D$ is provided to the base of transistor 1106 via connection 1110.

The emitters of transistors 1116 and 1118 are coupled together and to connection 1016 containing the clock phase module output Q-CLK. The collector of transistor 1116 is coupled to the collector of transistor 1106 and to the base of transistor 1118. The collector of transistor 1118 is coupled to the collector of transistor 1104, and to the base of transistor 1116.

When D-CLK goes high and Q-CLK goes low, transistors 1104 and 1106 become active, and transistors 1116 and 1118 become inactive. Under this condition, transistors 1104 and 1106 will "read" the states of D and $/D$ from connections 1108 and 1110 respectively. Conversely, when Q-CLK goes high, and D-CLK goes low, transistors 1104 and 1106 become inactive, and transistors 1116 and 1118 become active. Under this condition, transistors 1116 and 1118 will "write" the states of D and $/D$ (that were read immediately prior to the change in Q-CLK and D-CLK) onto connections 1122 and 1124 as outputs Q and $/Q$ respectively.

With continued reference to FIG. 11, FIG. 12 is a simplified timing diagram 1200 illustrating the operation of storage element 1100 as part of a “divide by three” frequency divider, such as, for example, frequency divider 500 (FIG. 5). For illustration purposes, timing diagram 1200 does not show gradual transitions between states and does not show all possible inputs and outputs. The timing diagram 1200 shows the following signals: CLK 1202, /CLK 1204, ϕ 1206, D-CLK 1208, Q-CLK 1210, D 1212, and Q 1214. These signals (1202, 1204, 1206, 1208, 1210, 1212, and 1214) may correspond, for example, to the signals carried by connections 1006, 1008, 1012, 1014, 1016, 1108, and 1122, respectively.

CLK 1202, /CLK 1204, ϕ 1206, and D 1212 are input signals; D-CLK 1208 and Q-CLK 1210 are internal storage element signals that are based on input signals 1202, 1204, and 1206; and Q 1214 is an output signal that is based on the input D 1212 and the internal signals D-CLK 1208 and Q-CLK 1210. The state of D-CLK 1208 is substantially equivalent to the state of CLK 1202 when ϕ 1206 is high (for example, between t_0 and t_3), and is substantially equivalent to the state of /CLK 1204 when ϕ 1206 is low (for example, between t_3 and t_6). Q-CLK 1210 is effectively the inverse of D-CLK. Therefore, the state of D-CLK 1208 is substantially equivalent to the state of /CLK 1204 when ϕ 1206 is high (for example, between t_0 and t_3), and is substantially equivalent to the state of CLK 1202 when ϕ 1206 is low (for example, between t_3 and t_6).

During a time interval when the state of D-CLK 1208 is high (for example, between t_1 and t_2), the value of D 1212 is “read” by storage element 1100. Subsequently, when the value of Q-CLK 1210 goes high (for example, at time t_2), the value of D 1212 that was read when the state of D-CLK 1208 was high is written as the output Q 1214. The value of Q then remains unchanged until Q-CLK 1210 goes high again (for example, at time t_5). As a result, the frequency of the output Q 1214 will be equal to one third of the frequency of the input CLK 1202.

While various embodiments of the invention have been described, it will be apparent to those of ordinary skill in the art that many more embodiments and implementations are possible that are within the scope of this invention.

What is claimed is:

1. A signal processing system configured to produce a divider output signal, the system comprising:

a plurality of storage elements;

where each of the plurality of storage elements is configured to receive a first input, a second input, and a reference input signal, and is configured to provide a storage element output;

where the divider output signal is obtained from at least one storage element output;

where a storage element output from each of the plurality of storage elements is used to provide at least one input to another one of the plurality of storage elements; and

where the storage element output from each of the plurality of storage elements is responsive to the storage element output from at least another one of the plurality of storage elements,

where the divider output signal has a period substantially equal to a period of the reference input signal multiplied by a frequency division ratio, where the frequency division ratio is equal to a total number of the plurality of storage elements,

where a phase difference between a first storage element output and a second storage element output is equal to 360° divided by twice the total number of the plurality of storage elements, and

where the signal processing system is implemented in a mobile communications device.

2. The signal processing system of claim 1, where with respect to each of the plurality of storage elements, a state of the first input is stored in the storage element at a first point in time.

3. The signal processing system of claim 2, where a state of the storage element output at a second point in time subsequent to the first point in time is equal to the state of the first input stored in the storage element at the first point in time.

4. The signal processing system of claim 1, where the divider output signal is obtained by combining two storage element outputs.

5. The signal processing system of claim 4, where a phase difference between a third harmonic component contained in a first storage element and a third harmonic component contained in a second storage element is substantially 180° .

6. The signal processing system of claim 5, where the third harmonic component contained in the first storage element output cancels out the third harmonic component contained in the second storage element output after the first storage element output and the second storage element output are combined.

7. The signal processing system of claim 6, where the divider output signal has a duty cycle substantially equal to 50%.

8. The signal processing system of claim 1, where the reference input signal is a local oscillator signal.

9. The signal processing system of claim 1, where the signal processing system is a frequency divider.

10. A method for producing a frequency divider output signal, comprising:

configuring each of a plurality of storage elements to receive a first input, a second input, and a reference input signal, and to provide a storage element output; obtaining a divider output signal from at least one of the storage element outputs, the divider output signal having a period substantially equal to a period of the reference input signal multiplied by a frequency division ratio, the frequency division ratio being equal to a total number of the plurality of storage elements; and using the storage element output from each of the plurality of storage elements as an input to another one of the plurality of storage elements,

where a phase difference between a first storage element output and a second storage element output is equal to 360° divided by twice the total number of the plurality of storage elements, and

where the method is implemented in a mobile communications device.

11. The method of claim 10, where with respect to each of the plurality of storage elements, a state of the first input is stored in the storage element at a first point in time.

12. The method of claim 11, where a state of the storage element output at a second point in time subsequent to the first point in time is equal to the state of the first input stored in the storage element at the first point in time.

13. The method of claim 10, where the divider output signal is obtained by combining two storage element outputs.

14. The method of claim 13, where a phase difference between a third harmonic component contained in a first

11

storage element and a third harmonic contained in a second storage element is substantially 180° .

15 **15.** The method of claim **14**, where the third harmonic component contained in the first storage element output cancels out the third harmonic component contained in the second storage element output.

16. The method of claim **10**, where the divider output signal has a duty cycle substantially equal to 50%.

17. The method of claim **10**, where the reference input signal is a local oscillator signal.

10 **18.** The method of claim **10**, where the method is implemented by a frequency divider.

19. A signal processing system configured to produce a divider output signal having a period substantially equal to three times a period of a reference input signal, the signal processing system comprising:

a first storage element;

a second storage element; and

a third storage element;

where each of the three storage elements is configured to receive a first input, a second input, and a reference input signal, and is configured to provide a storage element output;

where the divider output signal is obtained from at least one storage element output, where the divider output signal is obtained by combining two of the three storage element outputs; and

where the storage element output from each of the three storage elements is used to provide at least one input to another one of the three storage elements, where a phase difference between the output of the first storage element and the output of the second storage element is substantially equal to 60° , where a phase difference between a third harmonic component contained in the first storage element output and a third harmonic contained in the second storage element output is substantially 180° , where the third harmonic component contained in the first storage element output cancels out the third harmonic component contained in the second storage element output and where the signal processing system is implemented in mobile communications device.

15 **20.** The signal processing system of claim **19**, where each of the three storage elements comprises a plurality of transistors.

21. The signal processing system of claim **20**, where with respect to each of the three storage elements, a state of the first input is stored in the storage element at a first point in time.

20 **22.** The signal processing system of claim **21**, where a state of the storage element output at a second point in time

12

subsequent to the first point in time is equal to the state of the first input stored in the storage element at the first point in time.

23. The signal processing system of claim **19**, where the divider output signal has a duty cycle substantially equal to 50%.

24. The signal processing system of claim **19**, where the reference input signal is a local oscillator signal.

10 **25.** The signal processing system of claim **19**, where the signal processing system is a frequency divider.

26. A method for producing a frequency divider output signal having a period substantially equal to three times a period of a reference input signal, comprising:

15 configuring each of three storage elements to receive a first input, a second input, and a reference input signal, and to provide a storage element output;

obtaining a frequency divider output signal from at least one storage element output, where the frequency divider output signal is obtained by combining two of the three storage element outputs; and

using the storage element output from each of the three storage elements as an input to another one of the three storage elements, where a phase difference between the output of the first storage element and the output of the second storage element is substantially equal to 60° , where a phase difference between a third harmonic component contained in the first storage element output and a third harmonic component contained in the second storage element output is substantially 180° , where the third harmonic component contained in the first storage element output cancels out the third harmonic component contained in the second storage element output, and where the method is implemented in a mobile communication device.

27. The method of claim **26**, where each of the three storage elements comprises a plurality of transistors.

28. The method of claim **27**, where with respect to each of the three storage elements, a state of the first input is stored in the storage element at a first point in time.

20 **29.** The method of claim **28**, where a state of the storage element output at a second point in time subsequent to the first point in time is equal to the state of the first input stored in the storage element at the first point in time.

25 **30.** The method of claim **26**, where the frequency divider output signal has a duty cycle substantially equal to 50%.

31. The method of claim **26**, where the reference input signal is a local oscillator signal.

* * * * *

UNITED STATES PATENT AND TRADEMARK OFFICE
CERTIFICATE OF CORRECTION

PATENT NO. : 7,272,620 B1
APPLICATION NO. : 09/821833
DATED : September 18, 2007
INVENTOR(S) : Molnar et al.

Page 1 of 1

It is certified that error appears in the above-identified patent and that said Letters Patent is hereby corrected as shown below:

Column 10, line 58, delete "In" and replace with --in--.

Column 11, line 40, after "output" add --,--.

Column 12, line 35, delete "communication" and replace with --communications--.

Signed and Sealed this

Fifteenth Day of April, 2008

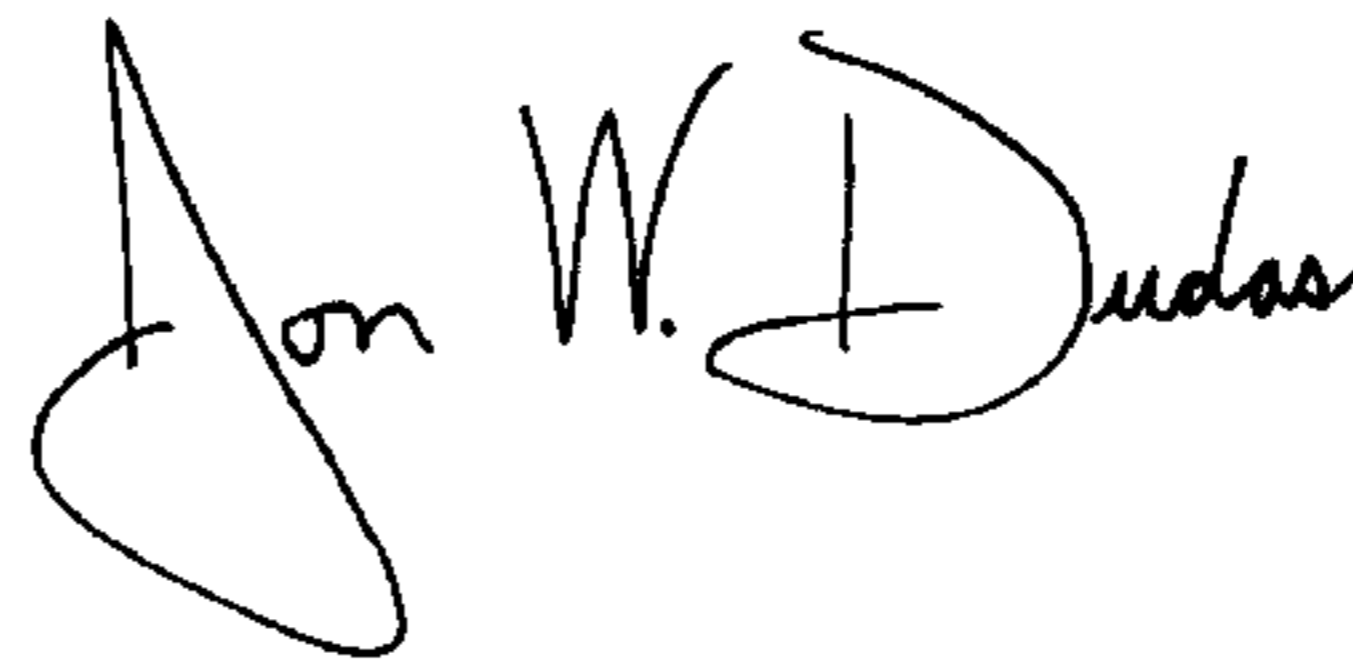
A handwritten signature in black ink that reads "Jon W. Dudas". The signature is written in a cursive style with a large initial "J" and "D".

JON W. DUDAS

Director of the United States Patent and Trademark Office