

US007261312B1

(12) **United States Patent**
Joplin

(10) **Patent No.:** **US 7,261,312 B1**
(45) **Date of Patent:** **Aug. 28, 2007**

(54) **TRAILER STABILIZATION AND WEIGHT DISTRIBUTION DEVICE**

(76) Inventor: **Benjamin P. Joplin**, 4430 Leasure Dr., Mt. Hood / Parkdale, OR (US) 97041

(*) Notice: Subject to any disclaimer, the term of this patent is extended or adjusted under 35 U.S.C. 154(b) by 0 days.

(21) Appl. No.: **10/817,022**

(22) Filed: **Apr. 2, 2004**

Related U.S. Application Data

(60) Provisional application No. 60/462,381, filed on Apr. 11, 2003.

(51) **Int. Cl.**
B60D 1/30 (2006.01)

(52) **U.S. Cl.** **280/455.1; 280/466.1**

(58) **Field of Classification Search** 280/432, 280/433, 441.2, 446.1, 455.1, 456.1, 457, 280/461.1, 474

See application file for complete search history.

(56) **References Cited**

U.S. PATENT DOCUMENTS

- 2,091,668 A * 8/1937 Bradford 280/455.1
- 2,768,837 A * 10/1956 Prater 280/455.1
- 3,955,831 A * 5/1976 Whitchurch 280/446.1
- 4,025,085 A 5/1977 Jacobs
- 4,040,507 A * 8/1977 Reise 280/455.1

- 4,133,552 A * 1/1979 Sheine 280/455.1
- 4,306,734 A 12/1981 Swanson et al.
- 4,313,616 A * 2/1982 Howard 280/455.1
- 4,662,647 A 5/1987 Calvert
- 4,756,543 A * 7/1988 Cromnow et al. 280/432
- 5,184,839 A 2/1993 Guedry
- 5,224,727 A * 7/1993 Ramskugler 280/432
- 5,785,341 A * 7/1998 Fenton 280/441
- 5,947,503 A * 9/1999 Tompkins 280/455.1
- 6,422,584 B1 * 7/2002 Bittroff et al. 280/432
- 6,688,631 B1 * 2/2004 Andre 280/455.1
- 2004/0021291 A1 * 2/2004 Haug et al. 280/455.1
- 2004/0232652 A1 * 11/2004 Namuduri et al. 280/455.1

* cited by examiner

Primary Examiner—Kevin Hurley

(74) *Attorney, Agent, or Firm*—Ipsolon llp

(57) **ABSTRACT**

A trailer-stabilizing device that stabilizes movement between a fifth-wheel trailer and the towing vehicle during normal trailering operations and that more effectively distributes the weight of the trailer to the towing vehicle is disclosed. The trailer-stabilizing device extends between the trailer and towing vehicle and is preferably positioned spaced apart from a traditional hitch and tongue connection pivotally securing the towing vehicle to the trailer. Preferably, the fifth-wheel trailer is pivotally secured to a conventional hitch within the bed of the pickup truck, and the stabilizing device is detachably secured to a conventional receiver on the back of the pickup truck.

25 Claims, 6 Drawing Sheets

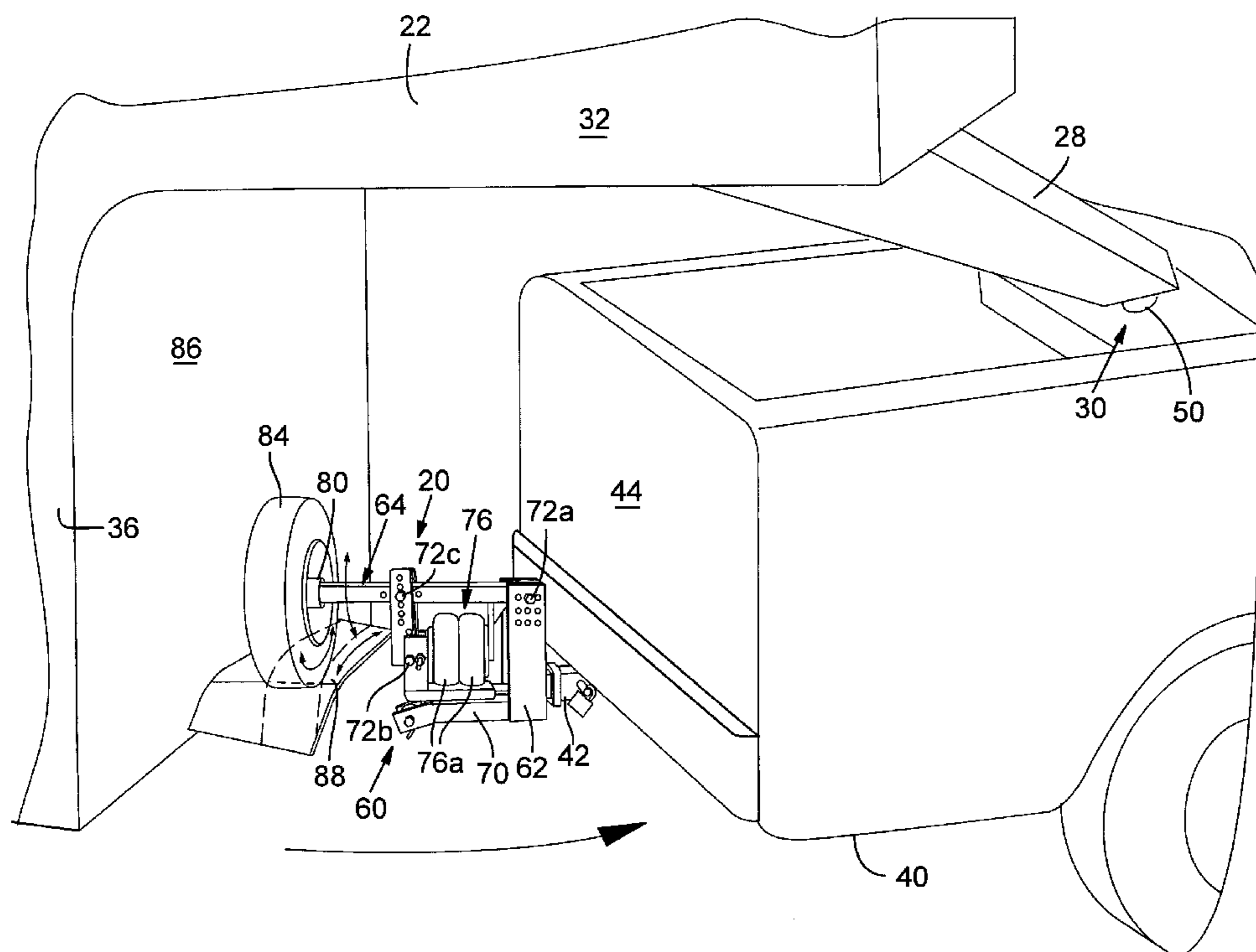

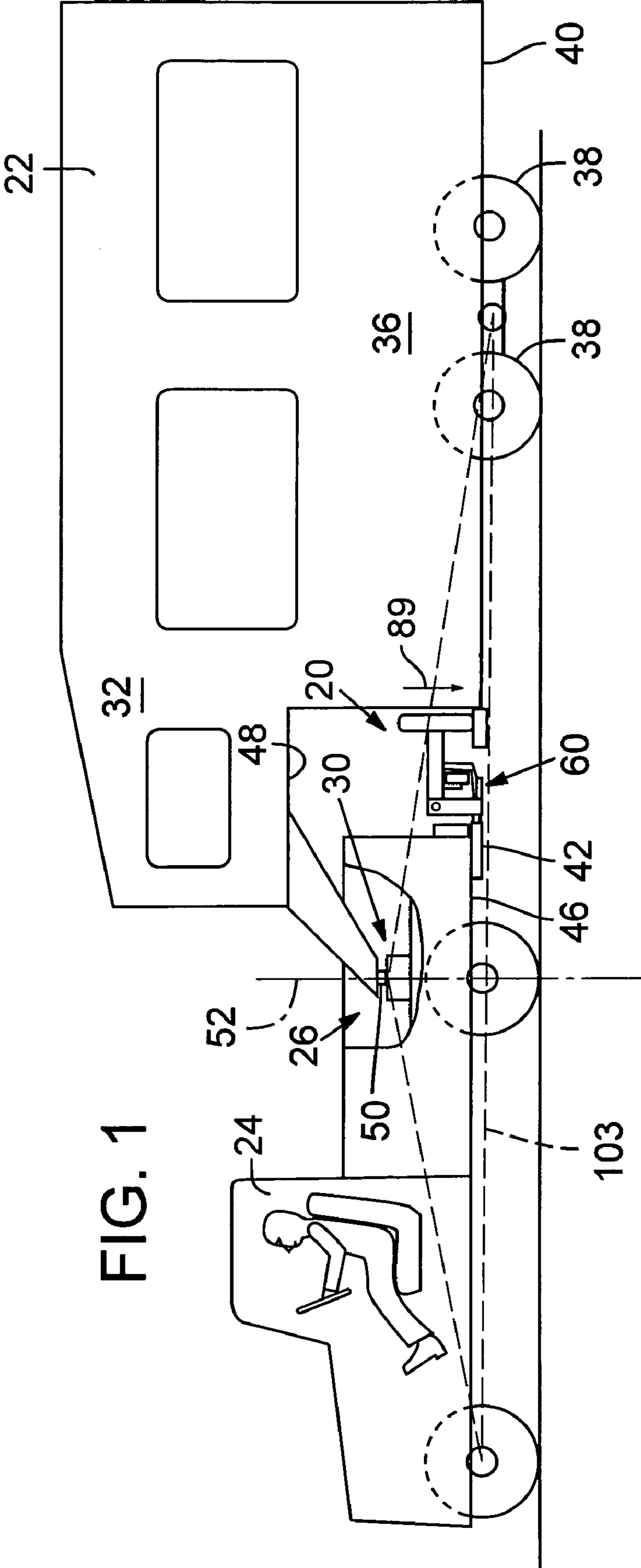
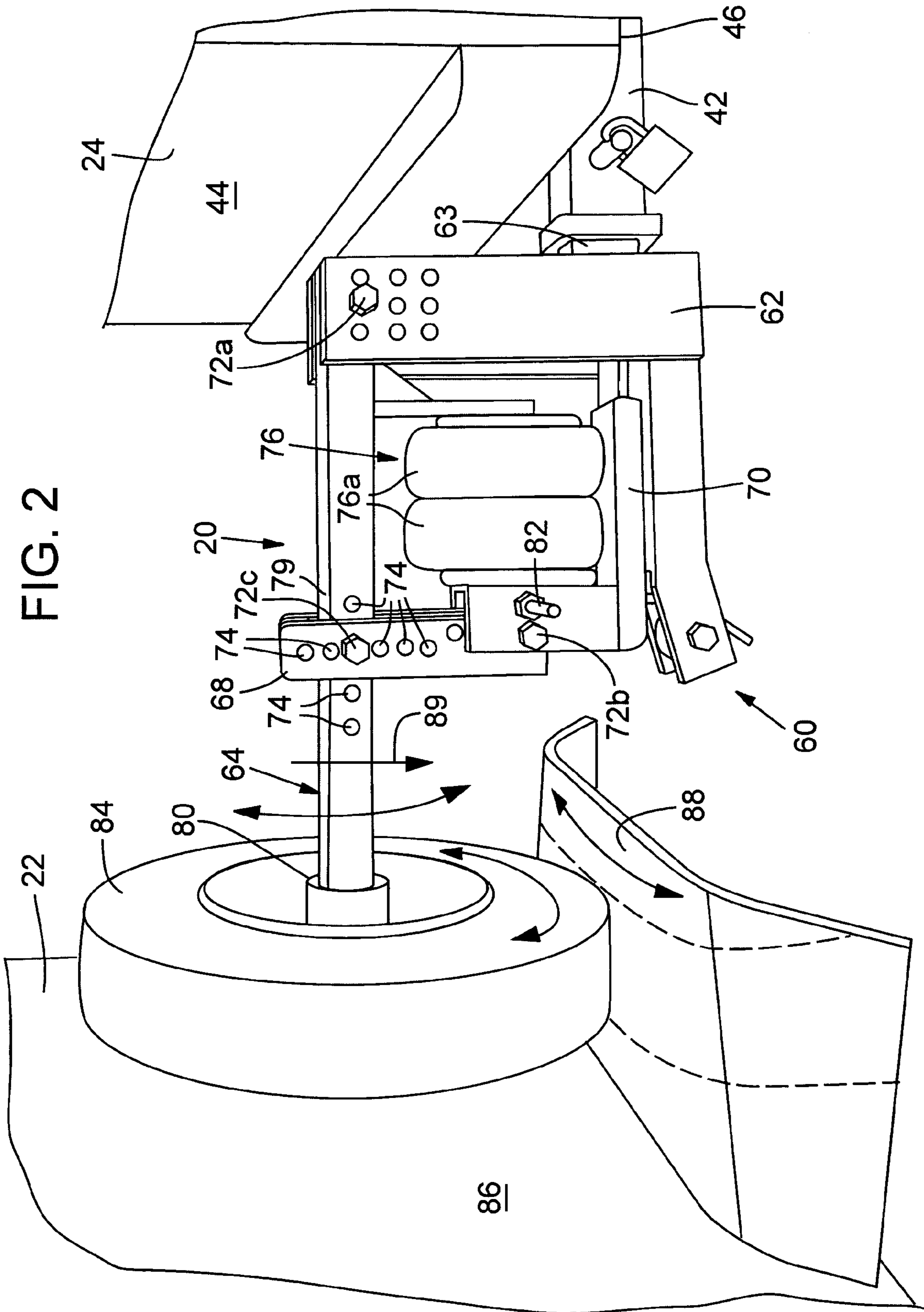
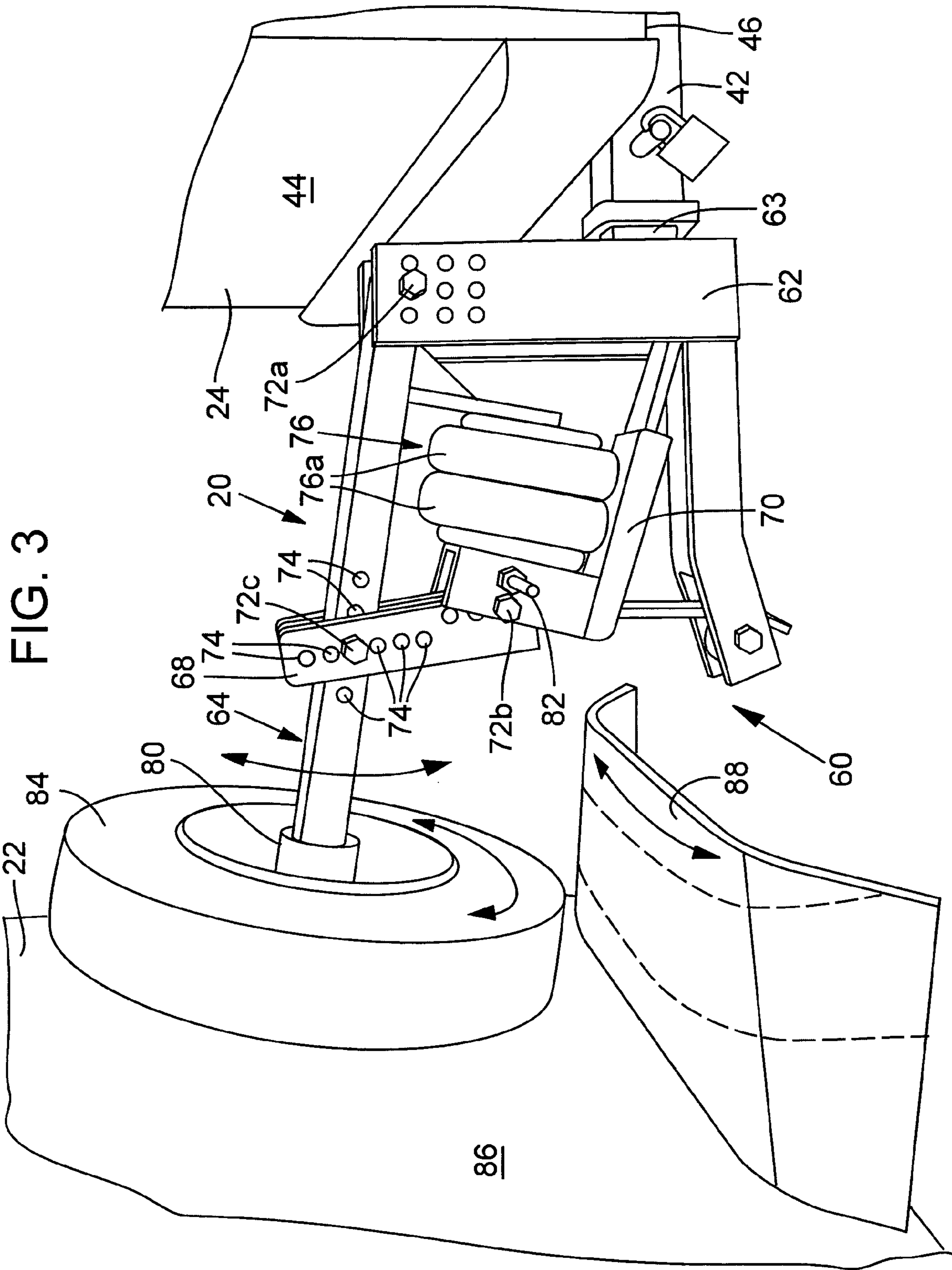
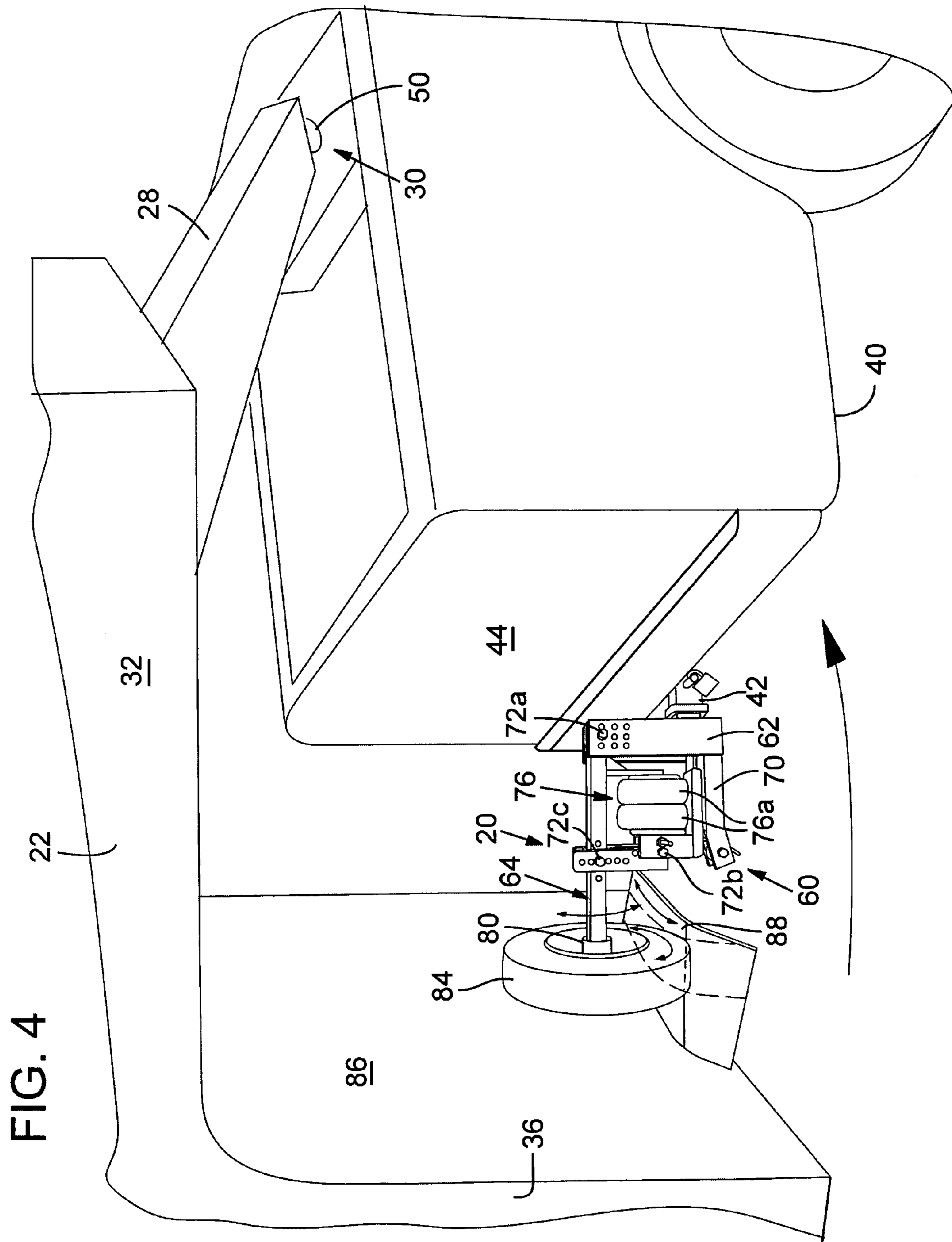
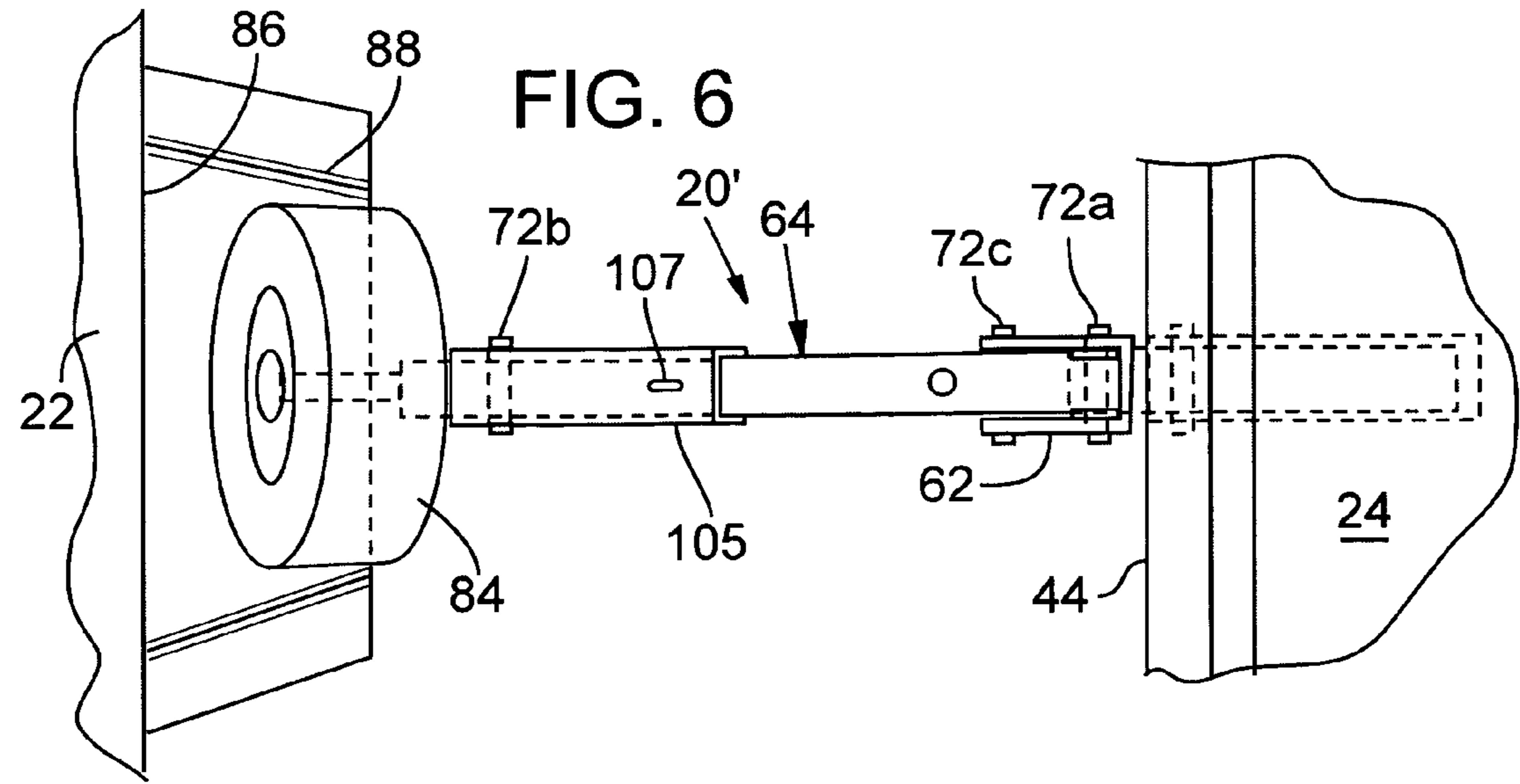
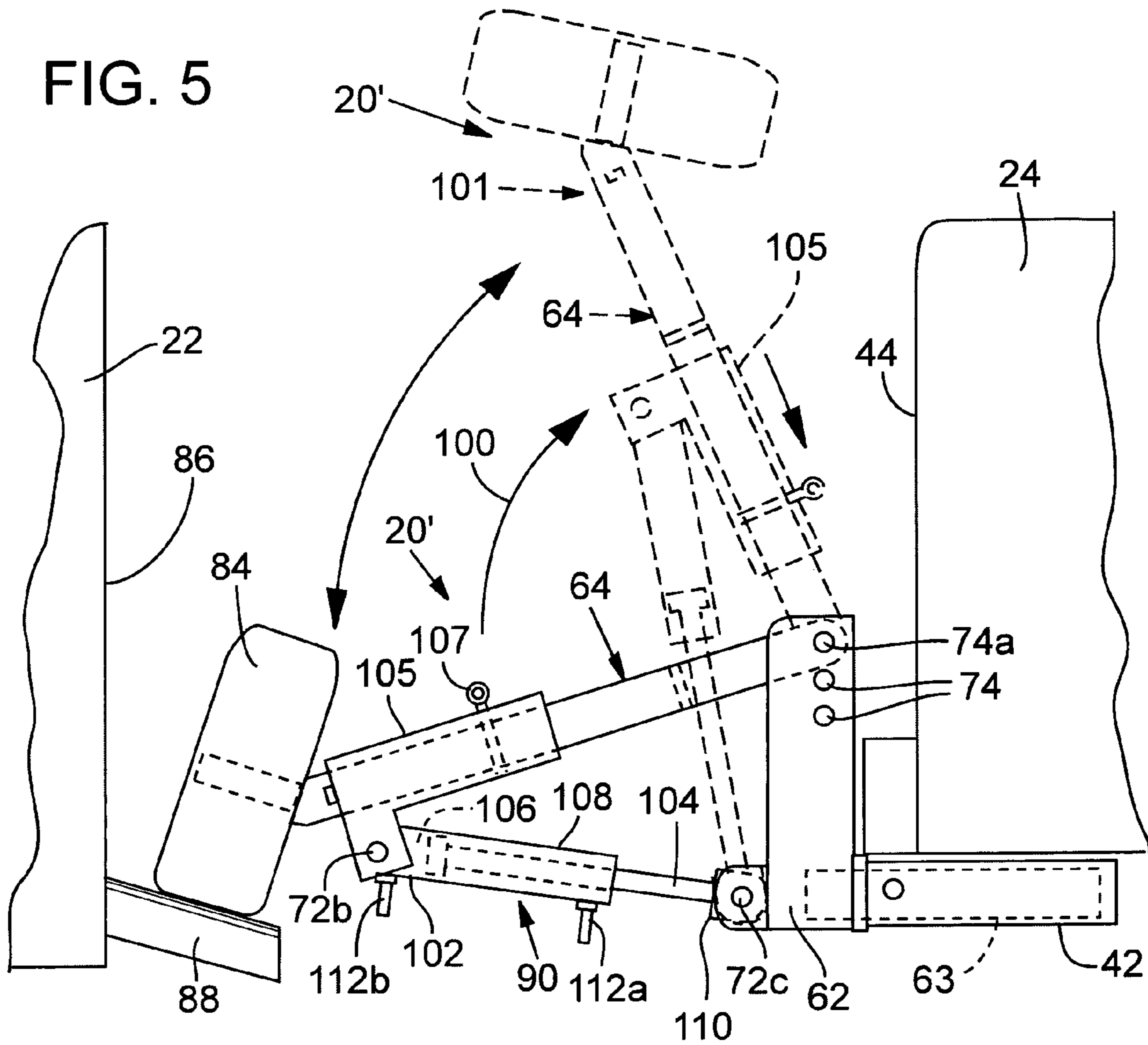

FIG. 2









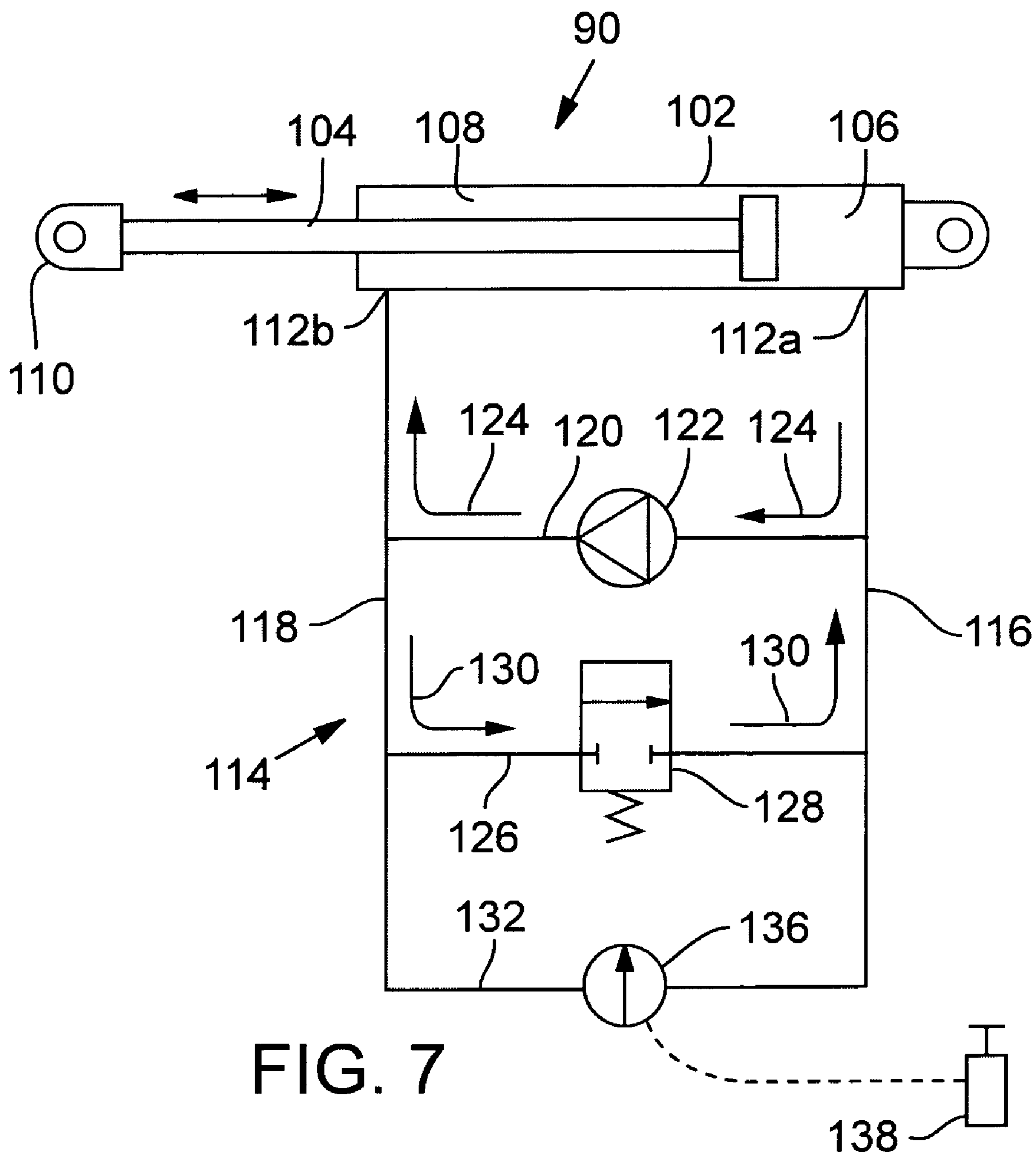

TRAILER STABILIZATION AND WEIGHT DISTRIBUTION DEVICE

CROSS REFERENCE TO RELATED APPLICATION

This application claims priority to U.S. provisional patent application No. 60/462,381 filed on Apr. 11, 2003.

TECHNICAL FIELD OF THE INVENTION

This invention relates to a device for stabilizing and improving the weight distribution of a trailer being towed by a vehicle.

BACKGROUND OF THE INVENTION

Trailers are towed vehicles that are operably secured to a towing vehicle, usually at a hitch or the like. One type of trailer in common use is known as a travel trailer, which is a towed vehicle usually having many of the conveniences of a home. A particularly popular travel trailer is known as a "fifth-wheel" trailer, which is adapted to be towed by a traditional pick-up truck. Namely, the forward portion of the fifth-wheel trailer is elevated above the bed of the pick-up truck and includes a mounting portion, or tongue, extending from the bottom of the elevated forward portion to a trailer mount, or hitch, secured to the bed of the pick-up truck.

Usually, the distal end of the tongue is usually pivotally secured to the hitch so that the towing vehicle and trailer can pivot with respect to each other about a defined pivot axis. This arrangement allows the towing vehicle and trailer to each have a turn radius that is sufficiently small so that both the towing vehicle and trailer can complete most turns found on conventional roads and the like. Preferably, the tongue is also detachably secured to the hitch so that the trailer may be easily attached and detached from the hitch.

Despite the benefits offered by conventional trailer tongues and hitches, they have several drawbacks. For example, the sole connection between the towing vehicle and trailer is at the pivot. Accordingly, all the pulling and braking forces offered by the towing vehicle are transferred to the trailer at this one location. Similarly, all forces generated by the trailer are transferred to the towing vehicle at this one location. This single point of connection at the pivot places enormous stress on the hitch and tongue, and can cause uneven weight and force distribution between the trailer and towed vehicle during some transient conditions, such as during acceleration and braking of the towing vehicle.

Efforts to improve the weight distribution and stabilization between a tongue & ball-type trailer and its towing vehicle have had limited success. For example, some trailer hitch manufacturers sell a product known as "sway control bars" that extend between the tongue of the trailer and ball on the towing vehicle to dampen side-to-side movement about the pivot. However, these structures also tend to limit the range of motion of the trailer about the pivot, thereby compromising the turn radius of the trailer and towing vehicle. Moreover, such structures are not adaptable for use with fifth-wheel trailers, where the tongue of the trailer connects to a trailer hitch resting in the bed of a pick-up truck-style towing vehicle.

SUMMARY OF THE INVENTION

Accordingly, despite the available structures for stabilizing and distributing the weight between a tongue & ball-type trailer and a towing vehicle, there remains a need for an economical device that stabilizes movement between a fifth-wheel trailer and the towing vehicle during normal trailering operations and that more effectively distributes the weight of the trailer to the towing vehicle. In addition to other benefits that will become apparent in the following disclosure, the present invention fulfills these needs.

The present invention is a trailer-stabilizing device that extends between the fifth-wheel trailer and towing vehicle at a position separate from the connection between the trailer's tongue and towing vehicle's hitch.

In a preferred embodiment, the towing vehicle is a pick-up truck with the tongue of the fifth-wheel trailer engaging the pick-up truck's hitch mounted within the bed of the pick-up truck. The trailer-stabilizing device is detachably secured to a conventional receiver mounted on the rear end of the pick-up truck, and extends from the back of the pick-up truck to operably engage the fifth wheel trailer.

Preferably, the trailer-stabilizing device engages the trailer to apply a downward biasing force during normal, substantially straight, trailering operations, such as found when driving substantially straight along a highway, switching lanes on a highway, accelerating or slowing the trailer and towing vehicle along a substantially flat surface, or the like. This downward biasing force coupled with the tongue of the trailer operably engaging the mount on the pick-up truck allows the stabilizing device to dampen transient movement between the trailer and pick-up truck and more evenly distribute the weight of the trailer to the pick-up truck, thereby preventing lurching and unstable movement of the trailer relative to the pick-up truck. Moreover, the biasing force essentially pretensions the connection between the tongue and hitch, thereby preventing movement between these structures during transient operations contribute to their premature wear and the like.

More preferably, the trailer-stabilizing device also decouples this biasing force from the trailer when maneuverability of the trailer relative to the vehicle must be maximized, such as while turning the pick-up truck and trailer at a street corner, backing up the trailer while turning, and transitioning from a substantially flat surface to a ramp or the like.

BRIEF DESCRIPTION OF THE DRAWINGS

FIG. 1 is a side view of a towing vehicle operably secured to a fifth-wheel trailer at a first hitch and also having a trailer-stabilizing device extending between the towing vehicle and trailer in accordance with an embodiment of the present invention.

FIG. 2 is a side, isometric view of a possible trailer-stabilizing device in an engaged position and in accordance with an embodiment of the present invention.

FIG. 3 is a side, isometric view of the trailer-stabilizing device of FIG. 2 showing a possible disengaged position in accordance with an embodiment of the present invention.

FIG. 4 is a side, isometric view of the trailer-stabilizing device of FIG. 2 showing a possible orientation between a towing vehicle and trailer during a turn.

FIG. 5 is a side view of an alternative trailer-stabilizing device in an engaged position in solid lines and a possible stored position in broken lines.

3

FIG. 6 is a top view of the alternative trailer-stabilizing device of FIG. 5.

FIG. 7 is an exemplar, schematic diagram of a possible pneumatic system in accordance with an embodiment of the present invention.

DETAILED DESCRIPTION

A trailer-stabilizing device 20 that extends between a fifth-wheel trailer 22 and towing vehicle 24 preferably at a position spaced apart and separate from the connection 26 between the trailer's tongue 28 and towing vehicle's hitch 30 is shown in FIGS. 1-7.

Preferably, the trailer 22 has a forward, elevated portion 32 and a main cabin 36 as best shown in FIGS. 1 and 4. At least one set of wheels 38 is operably secured to the lower side 40 of the main cabin 36. More preferably, the fifth-wheel trailer includes many of the conveniences of a home therein, such as a bathroom with plumbing, kitchen with working appliances and water, bedroom, living room, heating and electrical systems and the like. Another type of preferable trailer having a front elevated portion and main cabin is commonly used to transport animals therein.

The towing vehicle 24 is preferably a conventional pick-up truck of the like having a trailer hitch 30 operably secured within the bed of the pick-up truck. The towing vehicle includes an engine or the like and related structures for self-propelling and allowing operator steering and control of the towing vehicle. Preferably, a conventional receiver 42 is secured to the rear end 44 of the towing vehicle and positioned toward the lower end 46 of the towing vehicle 24.

The tongue 28 preferably extends from a lower side 48 of the forward, elevated portion 32 of the trailer 22. The distal end 50 of the tongue 28 is detachably and pivotally secured to the hitch 30 so that the towing vehicle 24 and trailer 22 can pivot with respect to each other about a defined pivot axis 52, thereby allowing the towing vehicle 24 to tow the trailer 22. Such tongues 28 and hitches 30 are well known in the art.

As best shown in FIGS. 1-4, the trailer-stabilizing device 20 is operably secured to the towing vehicle 24 and extends to operably engage the trailer 22 to apply a preferably downward biasing force on the main cabin 36 of the trailer. Preferably and as shown in FIGS. 1 and 2, the trailer-stabilizing device 20 engages the trailer 22 to apply the biasing force during normal, substantially straight, trailering operations, such as found when driving substantially straight along a highway, switching lanes on a highway, accelerating or slowing the trailer and towing the trailer 22 along a substantially flat surface, or the like.

This downward biasing force coupled with the tongue 28 of the trailer 22 operably engaging the hitch 30 on the pick-up truck allows the trailer-stabilizing device 20 to dampen transient movement between the trailer 22 and towing vehicle 24 and more evenly distribute the weight between them, thereby preventing lurching and unstable movement of the trailer 22 relative to the towing vehicle 24. Moreover, the biasing force essentially pretensions the connection between the tongue 28 and hitch 30, thereby preventing movement between these structures during transient operations that would otherwise contribute to premature wear or these components and the like.

More preferably and as shown in FIG. 4, the trailer-stabilizing device 20 also decouples this biasing force from the trailer 22 when maneuverability of the trailer 22 relative to the towing vehicle 24 must be maximized, such as while turning the towing vehicle 24 and trailer 22 at a street corner,

4

backing up the trailer 22 while turning, and transitioning from a substantially flat surface to a ramp or the like.

One known structure for providing this type of connection between the towing vehicle 24 and trailer 22 is shown in FIGS. 1-4. The trailer-stabilizing device 20 of this embodiment preferably includes a linkage 60 having a base portion 62 that operably engages the towing vehicle 24, and a trailer-engaging portion 64 that operably engages the trailer 22 and is pivotally secured to the base portion 62. More preferably, the linkage 60 is a four-bar linkage with the base portion 62 forming one link, the trailer-engaging portion 64 forming a second link, a stabilizing link 68 extending therebetween, and a biasing link 70. The base portion 62 is pivotally secured to the trailer-engaging portion 64 at a first pivot 72a. The trailer-engaging portion 64 is also pivotally secured to the stabilizing link 68 at a second pivot 72b, and the biasing link 70 is operably secured to the biasing link 70 as shown.

The base portion 62 preferably has a protrusion 63 that is sized to operably engage a traditional receiver 42 mounted to the rear end 44 of the towing vehicle 24 as shown. Also, the stabilizing link 68 and/or trailer-engaging portion each preferably include a plurality of adjustment holes 74, wherein the height of the distal end of the second link may be adjusted.

A biasing member 76, such as a resilient pneumatic chamber 76a, extends between the trailer-engaging portion 64 and the stabilizing link 68 to urge the distal end 80 of the trailer-engaging portion 64 in a downward direction. However, should an unusually large force be applied to the distal end 80 of the trailer-engaging portion 64, the trailer engaging portion pivots upward about the first pivot 72a as shown in FIG. 3, thereby minimizing the downward force on applied on the distal end 80.

The resilient pneumatic chamber 76a may be filled through a traditional pneumatic valve 82 in fluid communication with the pneumatic chamber 76a. Alternatively, the pneumatic chamber 76a may be operably secured to a remotely-actuated auxiliary pressurization system (not shown). In such case, the actuation control is preferably mounted within the driver compartment of the towing vehicle and within easy reach of the driver. Accordingly, the driver can pressurize the chamber on demand, thereby activating, deactivating, and adjusting the pressure applied by the trailer-stabilizing device 20 as needed.

Preferably, the distal end 80 of the trailer-engaging portion 64 includes a wheel 84 rotatably secured thereto. The front end 86 of the main cabin 36 of the trailer 22 includes a ramp 88 for operably engaging the wheel 84 when the trailer 22 and towing vehicle 24 are substantially longitudinally aligned. Accordingly, the wheel 84 applies a downward biasing force in the direction of arrow 89 (FIG. 2) to the ramp 88, thereby dampening movement of the trailer 22 with respect to the trailering vehicle 24 and effectively distributing the weight of the trailer 22. The ramp 88 is preferably rigidly secured directly to the chassis of the trailer.

Another exemplar structure for the trailer-stabilizing device 20' is shown in FIGS. 5-6. In order to reduce undue repetition, like elements with the previously described embodiment have like element numbers. The trailer-stabilizing device 20' of this embodiment preferably includes a linkage 60' having a base portion 62 that operably engages the towing vehicle 24, and a trailer-engaging portion 64 that operably engages the trailer 22 and is pivotally secured to the base portion 62 at first pivot 72a. Preferably, the base portion including a plurality of vertically aligned and

5

spaced-apart mounting openings for allowing the position of the first pivot **72a** to be selected and adjusted by the user simply by mounting the trailer-engaging portion **64** to a different mounting opening on the base portion.

Preferably, a pneumatic dampener **90** is pivotally secured 5 to the base position **62** and trailer-engaging portion **64** at pivots **92b**, **92c**, respectively. Accordingly, when the pneumatic dampener **90** is deactivated, the wheel **84** mounted to the distal end **80** of the trailer-engaging portion **64** can be pivoted away from the trailer about pivot **72a** and in the 10 direction of arrow **100**. More preferably, the trailer-engaging portion **64** can be stored in a stored position **101** (shown in broken lines in FIG. **5**) adjacent to the towing vehicle **24** when not in use. Preferably, a sliding sleeve **105** is pivotally 15 secured to the pneumatic dampener **90** and slidably received on the trailer-engaging portion **64**. Accordingly, the sleeve may be adjustably positioned along the trailer engaging portion, for example, by removing and replacing pin **107** along the trailer-engaging portion **64** as shown in FIG. **5**.

The pneumatic dampener **90** includes a base chamber **102** 20 and a piston-type structure **104** slidably secured therein defining a first pneumatic chamber **106** and a second pneumatic chamber **108**. The distal end **110** of the piston-type structure **104** is operably secured to the trailer-engaging 25 portion **64** at pivot **72c** and the base chamber **102** is operably secured the base portion **62** at pivot **72b**. Each pneumatic chamber **106**, **108** has a pneumatic port **112a**, **112b**, respectively, for adding and removing pneumatic load from the respective chambers.

Preferably, each pneumatic port **112a**, **112b** is in fluid 30 communication with a pneumatic regulator **114** that regulates pneumatic pressure in each chamber **106**, **108** based on predefined criteria. More preferably, pneumatic port **112a** is in fluid communication with a first manifold **116** and pneumatic port **112b** is in fluid communication with a second 35 manifold **118**. The first and second manifolds **116**, **118**, are preferably in fluid communication with each other though the following pneumatic links which are shown schematically in FIG. **7**.

- 1) A first pneumatic link **120** includes a one-way check 40 valve **122** that allows fluid from the first chamber **106** to travel to the second chamber **108** in the direction of arrows **124** until pressure between the two chambers **106**, **108** is equalized. Preferably, the wheel **84** operably engages the ramp **88**, which is rigidly secured to the trailer **22**. 45
- 2) A second pneumatic link **126** includes a pressure relief valve **128** that allows fluid from the second chamber **108** to travel to the first chamber **106** in the direction of 50 arrows **130** when pressure in either the first or second chambers **106**, **108** exceeds a predetermined limit. This allows the downward force provided by the trailer-stabilizing device **20** to the trailer **22** to be reduced or eliminated, essentially decoupling the trailer-stabilizing device **20** from the trailer **22** when excessive 55 pressure is achieved in the pneumatic chambers **106**, **108**, for example when the towing vehicle **24** starts up a steep hill while the trailer **22** initially remains essentially flat or the like.
- 3) A third pneumatic link **132** includes a manually actuated 60 valve **136** that allows the pressures between the first and second chambers **106**, **108** to be equalized. This valve **136** is preferably closed during normal operation of the trailer-stabilizing device **20**. However, this valve **136** can be opened manually to allow for manual deactivation of the trailer-stabilizing device **20**, 65 or to allow an operator to place the trailer-stabilizing

6

device **20** into the previously described stored position. Preferably, the manually-actuated valve **136** includes a remote actuator **138**, which is placed within reach of the driver of the towing vehicle when driving the towing vehicle.

The downward force applied in the direction of arrow **89** (FIGS. **1** & **2**) by the trailer-stabilizing device to the trailer during steady-state, non-extreme, towing of the trailer by the vehicle serves as a quasi and substantially rigid coupling between the towing vehicle and the trailer. As a result, the rear end of the towing vehicle and the adjacent trailer-stabilizing device engaging portion of the trailer are prevented from moving downward relative to each other. This coupling allows the towing vehicle and trailer to have a combined operating characteristic similar to having a common, substantially rigid truss extending along the entire longitudinal length **103** (FIG. **3**) of the combined towing vehicle and trailer. Accordingly, during normal, steady-state operations, the weight of the towing vehicle is more evenly distributed throughout the combined towing vehicle and trailer. Moreover, undesirable tilting and shifting between the towing vehicle and trailer is minimized.

However, and unlike actually having a substantially rigid truss extending between the towing vehicle and trailer, should the need arise to decouple the substantially rigid connection provided by the trailer-stabilizing device, such as excessive downward pressure being applied by the trailer-stabilizing device or the need to pivot the trailer relative to the towing vehicle during a turn or the like, the trailer-stabilizing device includes structures for decoupling the linkage between the towing vehicle and trailer. Accordingly, the towing vehicle and trailer have traditional operating characteristics during these extreme or dynamic operations.

In view of the wide variety of embodiments to which the principles of the invention can be applied, it should be apparent that the detailed embodiments are illustrative only and should not be taken as limiting the scope of the invention. Rather, the claimed invention includes all such modifications as may come within the scope of the following claims and equivalents thereto.

I claim:

1. A trailer-stabilizing device operably extending between a towing vehicle and a fifth-wheel trailer, said trailer-stabilizing device having:
 - a linkage extendable between said towing vehicle and said trailer;
 - an engaged position in which said linkage extends between said fifth-wheel trailer and said towing vehicle to apply a dampening force to the fifth-wheel trailer,
 - a disengaged position in which the linkage is disconnected between said towing vehicle and said fifth-wheel trailer;
 - a regulator for commanding the trailer-stabilizing device between said engaged position and said disengaged position; and,
 - wherein said linkage includes,
 - an arm pivotally secured to a base;
 - a wheel rotatably secured toward a distal end of said arm;
 - and,
 - said wheel operably engages a ramp extending from said trailer when said trailer-stabilizing device is in said engaged position.
2. The trailer-stabilizing device of claim **1**, wherein said trailer-stabilizing device is in said engaged position when said towing vehicle and said trailer are traveling substantially straight.

7

3. The trailer-stabilizing device of claim 1, wherein said wheel disengages said ramp when said trailer is in said disengaged position.

4. The trailer-stabilizing device of claim 3, wherein said trailer-stabilizing device is in said disengaged position when said towing vehicle and said trailer are turning.

5. The trailer-stabilizing device of claim 1, wherein said dampening force is provided by a pneumatic chamber operably secured to said trailer-stabilizing device.

6. The trailer-stabilizing device of claim 5, wherein said pneumatic chamber is substantially flexible.

7. The trailer-stabilizing device of claim 5, wherein said pneumatic chamber is a pneumatic cylinder.

8. The trailer-stabilizing device of claim 3, wherein said regulator includes a pressure relief valve that activates when a predefined upper pressure is achieved in the pneumatic chamber.

9. The trailer-stabilizing device of claim 8, wherein said regulator includes a manually actuated pressure relief valve.

10. The trailer-stabilizing device of claim 9, wherein: said manually actuated pressure relief valve has a control handle;

and said towing vehicle has a driver's compartment;

and said control handle is positioned within said driver's compartment so that a driver of the vehicle may activate the control handle from within said driver's compartment.

11. A trailer-stabilizing device operably extending between a pick-up truck and a fifth-wheel trailer, said trailer-stabilizing device having:

a linkage extendable between said pick-up truck and said trailer;

an engaged position in which said linkage extends between said fifth-wheel trailer and said pick-up truck to apply a dampening force to the fifth-wheel trailer;

a disengaged position in which the linkage is disconnected between said pickup-up truck and said fifth-wheel trailer;

a regulator for commanding the trailer-stabilizing device between said engaged position and said disengaged position; and,

wherein said linkage has a stored position wherein said trailer-stabilizing device does not extend between said towing vehicle and said trailer; and,

said linkage is pivotally secured to said towing vehicle and pivoted upward away from said trailer in said stored position.

12. The trailer-stabilizing device of claim 11, wherein said linkage may be secured in said stored position.

13. A trailer-stabilizing device extending between a pick-up truck and a fifth-wheel trailer, said pick-up truck having a rear end with a receiver secured thereto, said trailer-stabilizing device detachably secured to said receiver and having:

a dampener operably connected to said pick-up truck and said fifth-wheel trailer, said dampener having an engaged position in which said dampener applies a dampening force to the fifth wheel trailer,

said dampener having a disengaged position in which the dampening force is not substantially applied to the fifth-wheel trailer; and,

a regulator for commanding the dampener between said engaged position and said disengaged position.

14. The trailer-stabilizing device of claim 13, wherein said trailer-stabilizing device includes a linkage extending between said pick-up truck and said fifth-wheel trailer.

8

15. The trailer-stabilizing device of claim 14, wherein said linkage is substantially a four bar linkage.

16. A trailer-stabilizing device extending between a pick-up truck and a fifth-wheel trailer, said trailer-stabilizing device having:

an engaged position in which said trailer-stabilizing device operably engages said fifth-wheel trailer and said pick-up truck to apply a dampening force to the trailer,

a disengaged position in which the dampening force is not substantially applied to the fifth-wheel trailer;

a regulator for commanding the trailer-stabilizing device between said engaged position and said disengaged position;

said trailer-stabilizing device secured between the pick-up truck and the fifth-wheel trailer at a position spaced apart from a hitch connecting the towing vehicle to the trailer; and,

wherein said pick-up truck has a rear end with a receiver secured thereto, and said trailer-stabilizing device is detachably secured to said receiver.

17. The trailer-stabilizing device of claim 16, wherein said trailer-stabilizing device includes a linkage extending between said pick-up truck and said trailer.

18. The trailer-stabilizing device of claim 17, wherein said linkage is substantially a four bar linkage.

19. A trailer-stabilizing device extending between a pick-up truck and a fifth-wheel trailer, said trailer-stabilizing device having:

an engaged position in which said trailer-stabilizing device operably engages said fifth-wheel trailer and said pick-up truck to apply a dampening force to the trailer,

a disengaged position in which the dampening force is not substantially applied to the fifth-wheel trailer; and,

a regulator for commanding the trailer-stabilizing device between said engaged position and said disengaged position;

wherein the trailer has a main cabin, and said dampening force is a substantially downward force applied by the trailer-stabilizing device to the main cabin; and,

wherein said pick-up truck has a rear end with a receiver secured thereto, and said trailer-stabilizing device is detachably secured to said receiver.

20. The trailer-stabilizing device of claim 19, wherein said trailer-stabilizing device includes a linkage extending between said pick-up truck and said trailer.

21. A trailer-stabilizing device extending between a pick-up truck and a fifth-wheel trailer, said trailer-stabilizing device having:

an engaged position in which said trailer-stabilizing device operably engages said fifth-wheel trailer and said pick-up truck to apply a dampening force to the trailer,

a disengaged position in which the dampening force is not substantially applied to the fifth-wheel trailer; and,

a regulator for commanding the trailer-stabilizing device between said engaged position and said disengaged position;

wherein the trailer has a main cabin, and said dampening force is a substantially downward force applied by the trailer-stabilizing device to the main cabin; and,

wherein said linkage is substantially a four bar linkage.

9

22. The trailer-stabilizing device of claim **21**, wherein said trailer-stabilizing device is in said engaged position when said towing vehicle and said trailer are traveling substantially straight.

23. The trailer-stabilizing device of claim **21**, wherein said trailer-stabilizing stabilizing device is in said disengaged position when said towing vehicle and said trailer are turning.

10

24. The trailer-stabilizing device of claim **21**, wherein said trailer-stabilizing device is in said engaged position when said towing vehicle and said trailer are traveling substantially straight.

25. The trailer-stabilizing device of claim **21**, wherein said trailer-stabilizing device is in said disengaged position when said towing vehicle and said trailer are turning.

* * * * *