



US007255028B1

(12) **United States Patent**
Di Bitonto et al.

(10) **Patent No.:** **US 7,255,028 B1**
(45) **Date of Patent:** **Aug. 14, 2007**

(54) **MULTI-BIT PRECISION SCREWDRIVER**

(75) Inventors: **Anthony Di Bitonto**, Brooklyn, NY (US); **Anton Ljunggren**, New York, NY (US); **Paul Katz**, New York, NY (US); **Michael Circosta**, New York, NY (US); **Boris Kontorovich**, Brooklyn, NY (US)

(73) Assignee: **Helen of Troy Limited**, St. Michael (BB)

(*) Notice: Subject to any disclaimer, the term of this patent is extended or adjusted under 35 U.S.C. 154(b) by 0 days.

5,228,363 A	7/1993	Corona et al.	
5,337,637 A	8/1994	Bih-Lien	
5,442,982 A	8/1995	Bell	
5,526,724 A *	6/1996	Bruggeman	81/492
5,566,596 A	10/1996	Lin	
5,613,413 A	3/1997	Huang	
5,673,600 A	10/1997	Yanagi et al.	
5,823,078 A	10/1998	Liu	
5,868,048 A	2/1999	Cassutti et al.	
5,904,080 A *	5/1999	Anderson et al.	81/439
5,924,339 A *	7/1999	Huang	81/57.31
6,050,158 A	4/2000	Cassutti et al.	

(Continued)

(21) Appl. No.: **11/436,105**

FOREIGN PATENT DOCUMENTS

(22) Filed: **May 17, 2006**

WO WO89/03282 4/1989

(51) **Int. Cl.**

B25B 23/00 (2006.01)
B25G 1/08 (2006.01)
B25B 23/16 (2006.01)

Primary Examiner—David B. Thomas
(74) *Attorney, Agent, or Firm*—O’Keefe, Egan, Peterman & Enders, LLP

(52) **U.S. Cl.** **81/439; 81/492**

(58) **Field of Classification Search** 81/439, 81/492; 7/165

See application file for complete search history.

(57) **ABSTRACT**

In one embodiment, a screwdriver having interchangeable bit bodies with permanently affixed bit heads is provided. In another embodiment, at least one transparent end cap is provided to display a bit head in an engaged position ready for use. In another alternative embodiment, transparent end caps are provided at two ends of the screwdriver. In still another embodiment, two end caps are provided that may nest with each other. In yet another embodiment a rotatable end cap is provided. The various embodiments of the precision screwdriver may be utilized independently or in combination. One combination provides a screwdriver comprising two transparent, nesting, and rotating caps. A user can apply pressure to an end cap top (whether nested or not) to stabilize the screwdriver for a particular job while rotating the screwdriver independent of the nesting cap top.

(56) **References Cited**

U.S. PATENT DOCUMENTS

686,424 A *	11/1901	Smith	81/438
1,250,328 A *	12/1917	Langford	81/436
2,022,775 A *	12/1935	Holland-Letz	81/439
2,196,849 A *	4/1940	Beeg	81/439
3,114,401 A *	12/1963	Johnson	81/438
3,753,455 A	8/1973	Butler	
4,300,607 A *	11/1981	Mellinger	81/490
4,372,362 A	2/1983	Ahn	
4,463,788 A	8/1984	Corona et al.	
4,572,038 A	2/1986	Graham	
4,846,042 A *	7/1989	Wetty	81/490
4,867,326 A *	9/1989	O’Meara	215/250
4,924,733 A *	5/1990	McKenzie	81/438
4,969,231 A *	11/1990	Mader et al.	16/421

26 Claims, 5 Drawing Sheets

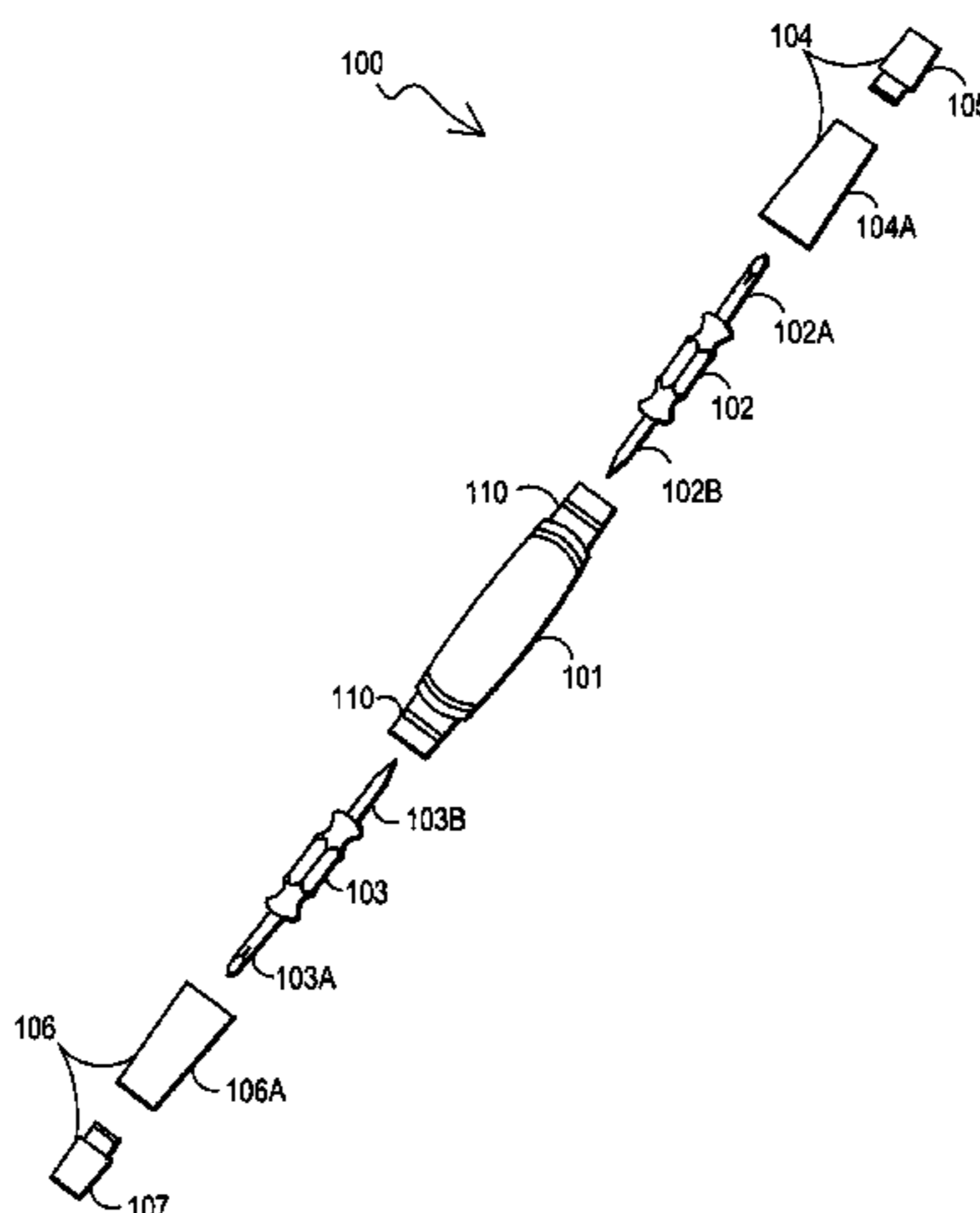

US 7,255,028 B1

Page 2

U.S. PATENT DOCUMENTS							
			6,923,099	B2	8/2005	Rugg et al.	
			7,052,128	B1 *	5/2006	Kung-Ping 351/42	
6,186,036	B1	2/2001	Huang				
6,237,451	B1	5/2001	Wei	2003/0029283	A1	2/2003	Yaar
6,332,384	B1	12/2001	Cluthe	2003/0084758	A1	5/2003	Chiang
6,354,177	B2	3/2002	Peters	2004/0065178	A1	4/2004	Anderson et al.
6,374,711	B2	4/2002	Anderson et al.	2004/0123705	A1 *	7/2004	Howard 81/492
6,502,484	B2	1/2003	Pao-His	2004/0129119	A1	7/2004	Clarke et al.
6,508,156	B1	1/2003	Wei	2004/0139832	A1	7/2004	Hu
6,601,483	B2	8/2003	Wannop	2005/0204878	A1	9/2005	Hu
6,629,478	B2	10/2003	Kozak				
6,655,243	B2 *	12/2003	Anderson et al.	81/490			* cited by examiner

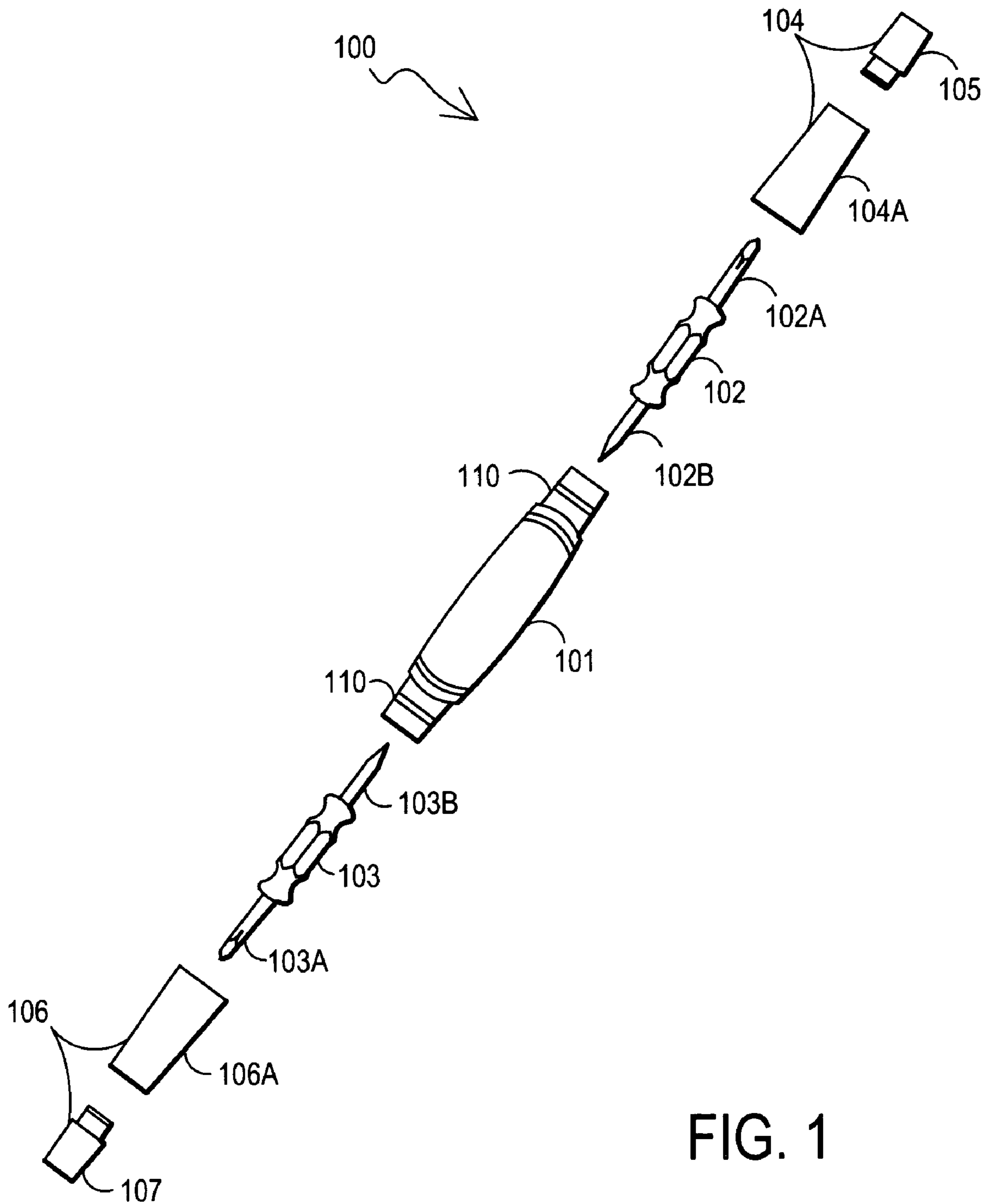

FIG. 1

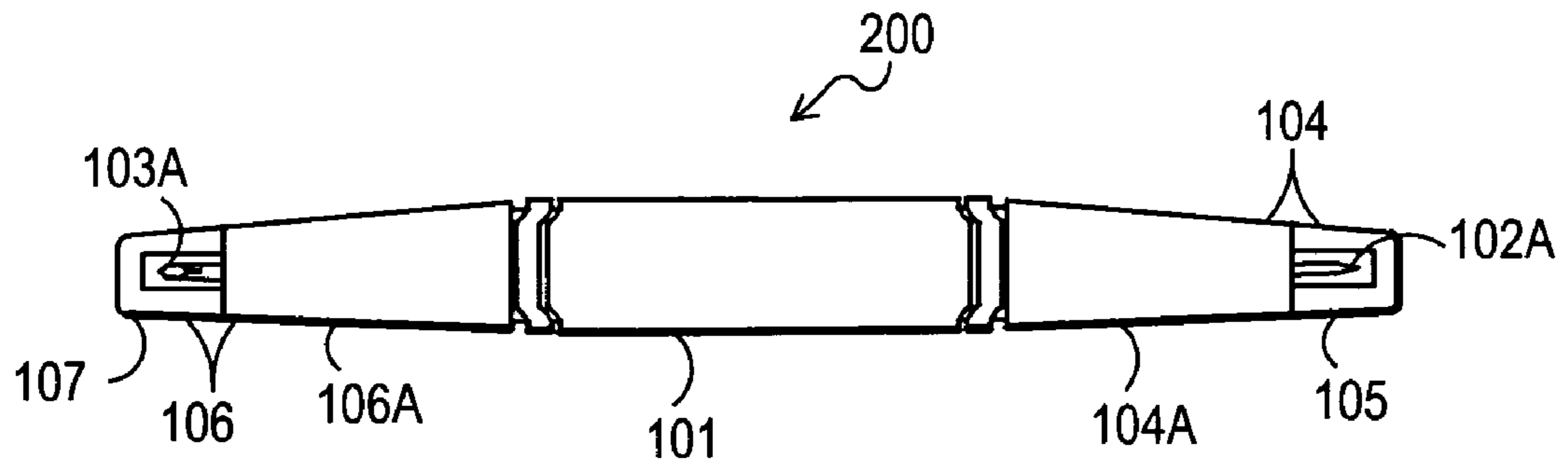

FIG. 2

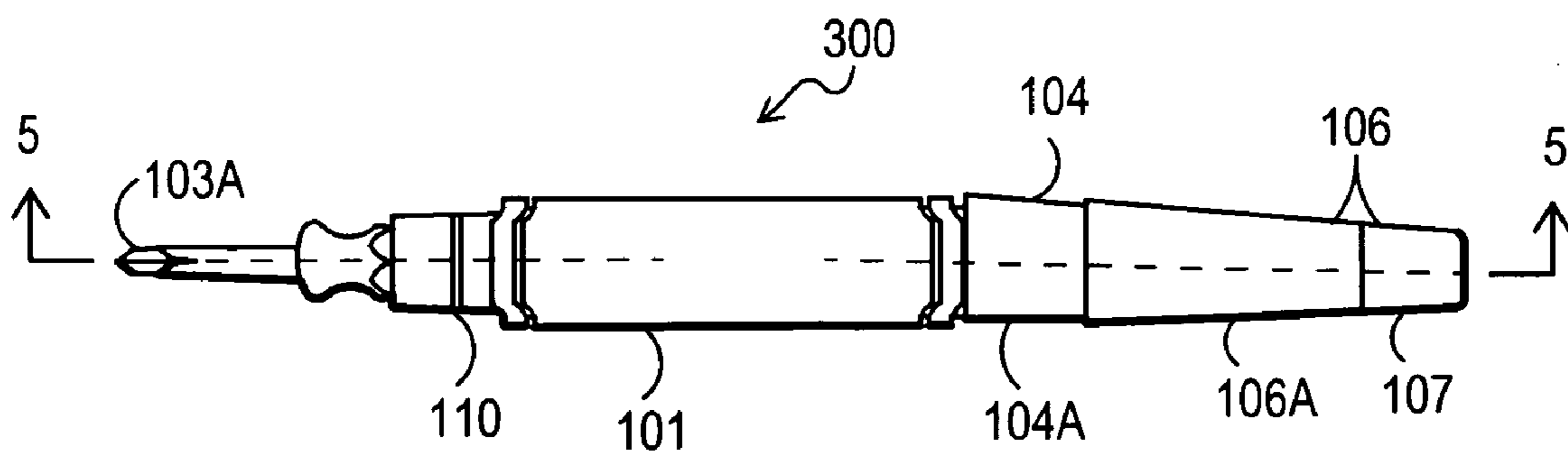
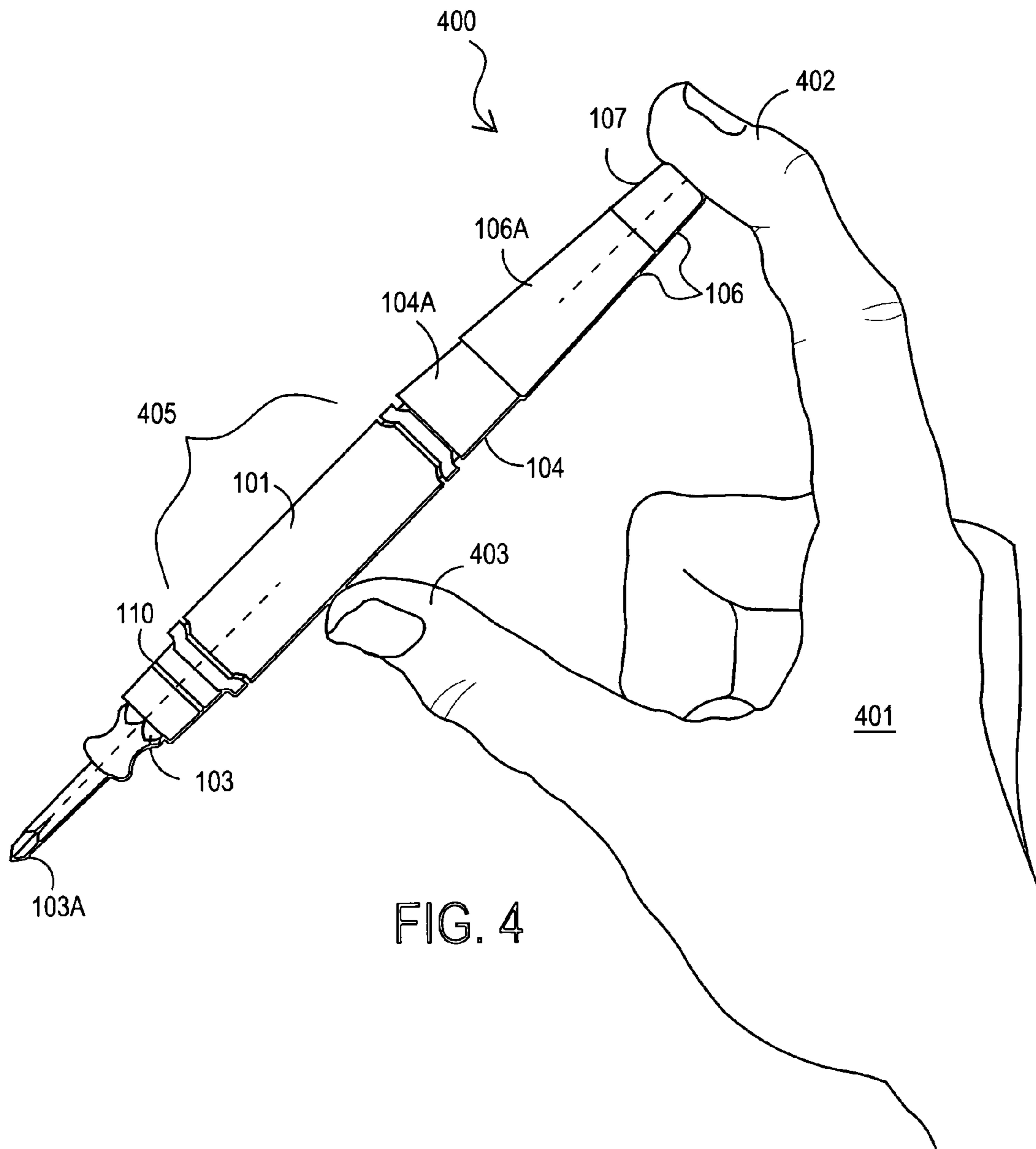

FIG. 3



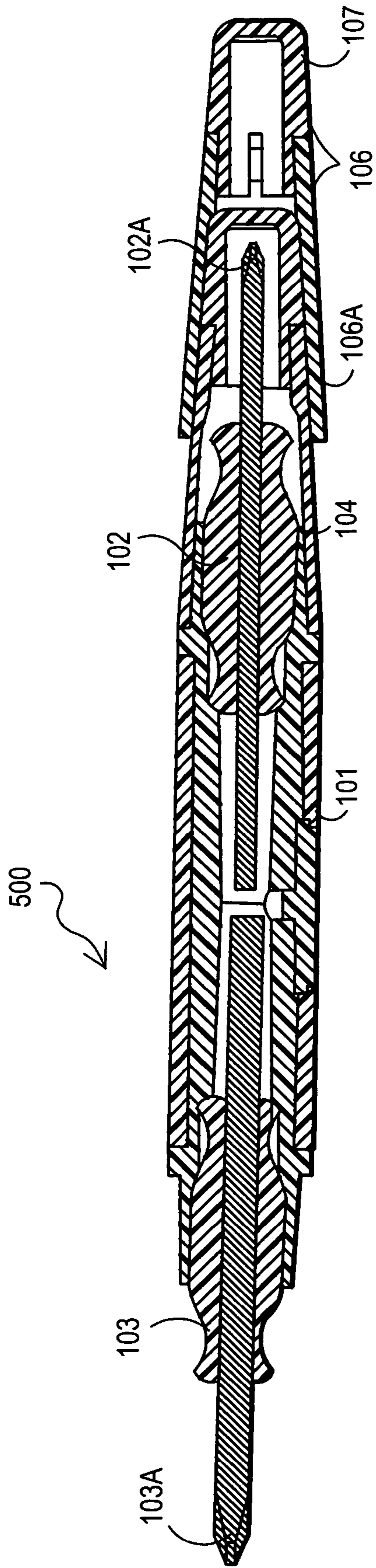

FIG. 5

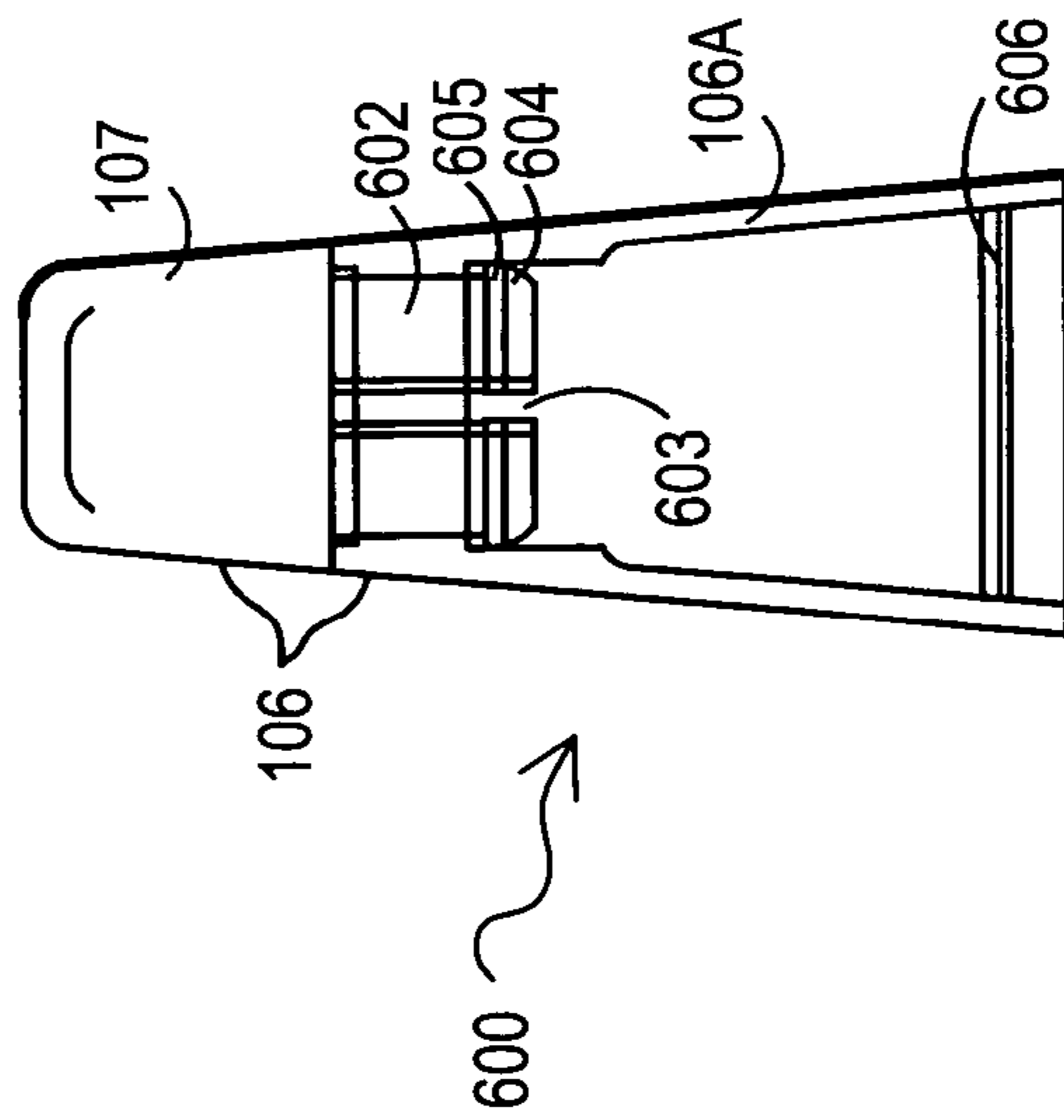

FIG. 6

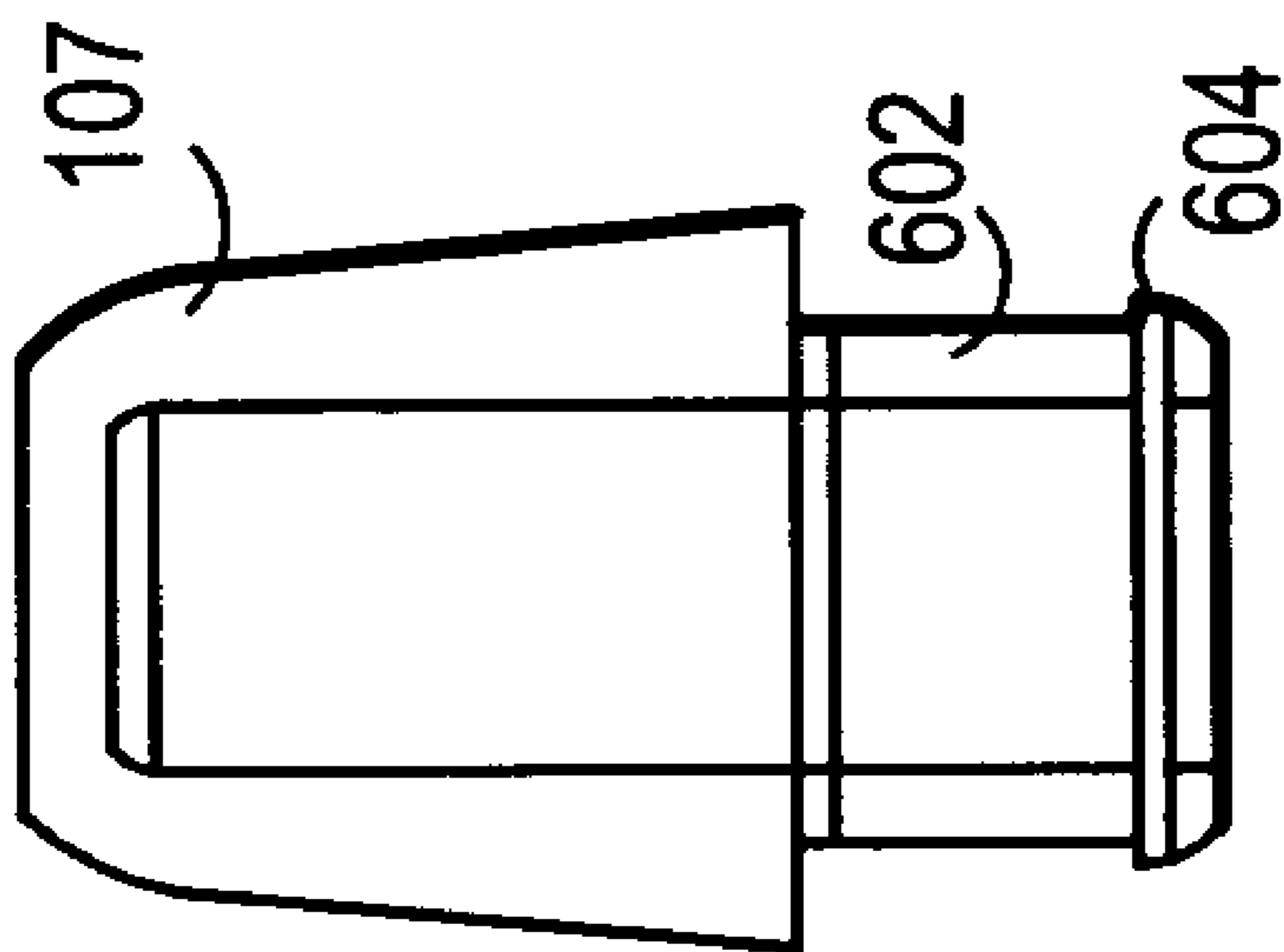

FIG. 8

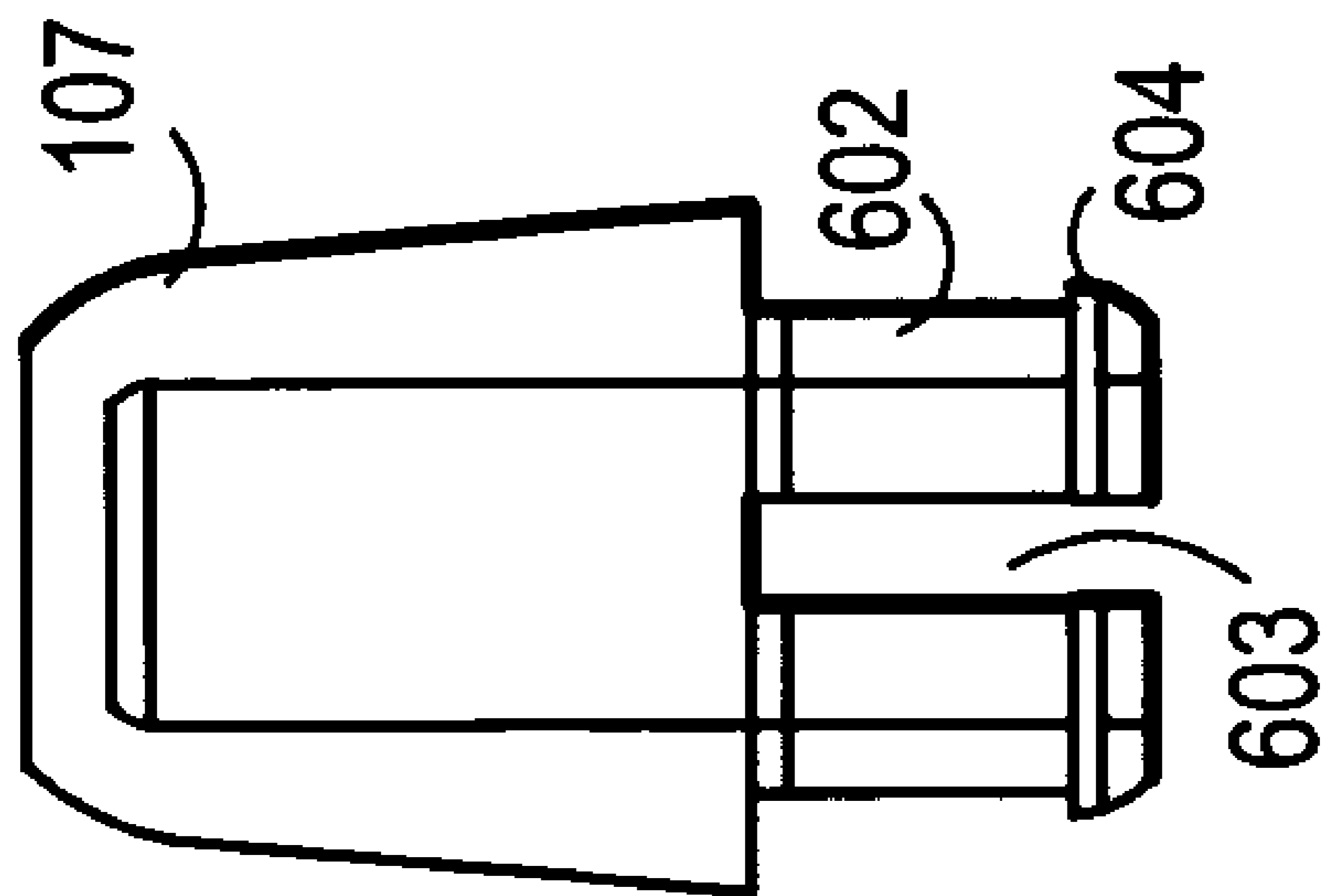

FIG. 7

MULTI-BIT PRECISION SCREWDRIVER

TECHNICAL FIELD OF THE INVENTION

This present disclosure relates to precision screwdrivers, and more particularly, to screwdrivers having multiple bits.

BACKGROUND

A variety of types of precision screwdrivers are known in the art. Generally, such screwdrivers provide a small handy screwdriver that may be used for a variety of applications. The portability and functionality of such screwdrivers is often assisted by the provision of multiple screwdriver bits that may be utilized with a single screwdriver. Some of such screwdrivers are formed in a "pen-like" shape having an end cap such that the screwdriver may be easily carried in a shirt pocket or the like. Often, the storage of additional bits, the ease of use of such screwdrivers, the end caps of such screwdrivers have characteristics that result in an inefficient use, a clumsy retention of the various components and a general lack of "user friendliness."

SUMMARY OF THE INVENTION

A precision screwdriver is disclosed having a variety of embodiments for improving efficiency and use. In one embodiment, a screwdriver having interchangeable bit bodies with permanently affixed bit heads is provided. In another embodiment, at least one transparent end cap is provided to display a bit head in an engaged position ready for use. In another alternative, transparent end caps are provided at two ends of the screwdriver. In still another embodiment, two end caps are provided that may nest with each other. In yet another embodiment, a rotatable end cap is provided. The various embodiments of the precision screwdriver may be utilized independently or in combination with one or more of the other embodiments. In one combinational embodiment, a screwdriver comprising two transparent, nesting, and rotating caps is provided. In this embodiment multiple bit heads are displayed in an engaged position ready for use. Nesting end caps at each end of the screwdriver have rotatable tops. Nesting caps can be removed and temporarily affixed to each other, while still allowing for rotation whether stacked or not. A user can apply pressure to an end cap top (whether nested or not) to stabilize the screwdriver as necessary for a particular job while rotating the screwdriver independent of the nesting cap top.

In one embodiment, a screwdriver is provided. The screwdriver may comprise a main body configured to hold a bit body in place. The screwdriver may further include a first end of the screwdriver having a first end cap, the first end cap having a first end cap first portion and a first end cap second portion. The screwdriver may also have a second end of the screwdriver being located at an end opposite of the first end, the second end having a second end cap the second end cap having a second end cap first portion and a second end cap second portion. The screwdriver may be configured such that when each of the end caps is configured to allow rotation between the first portion of the end cap and the second portion of the end cap.

In another embodiment, a screwdriver is provided that comprises a first removable nesting end cap and a second removable nesting end cap, the first and second removable nesting end caps configured to nest with each other. Further, when the first removable nesting end cap and the second

removable nesting end cap are nested, a portion of the outer of the two end caps rotates freely with respect to the inner of the two end caps.

In still another embodiment, a screwdriver may comprise a main body configured to hold at least two bit heads, a first bit head at a first end of the screwdriver and second bit head at a second end of the screwdriver. The screwdriver may also include a first end cap covering the first bit head and a second end cap covering the second bit head. Further, the first and second end caps are each configured to allow rotation between first portion of the end cap and a second portion of the end cap

In another embodiment, a screwdriver may comprise a main body configured to hold a first bit head and a second bit head, the first and second bit heads being in an engaged position ready for use, the first bit head being at a first end of the screwdriver and the second bit head being at a second end of the screwdriver. The screwdriver may further include a first transparent cap for exposing at least a portion of the first bit head while covering the first bit head while the first bit head is in the engaged position ready for use and a second transparent cap for exposing at least a portion of the second bit head covering the second bit head while the second bit head is in the engaged position ready for use.

DESCRIPTION OF THE DRAWINGS

It is noted that the appended drawings illustrate only exemplary embodiments of the invention and are, therefore, not to be considered limiting of its scope, for the invention may admit to other equally effective embodiments.

FIG. 1 is an exploded view of a screwdriver.

FIG. 2 is a side view of a screwdriver with end caps on both ends.

FIG. 3 is a side view of a screwdriver with a first nesting end cap attached to a second nesting end cap.

FIG. 4 is a side view of a screwdriver in use.

FIG. 5 is a cross section side view of a screwdriver.

FIG. 6 is a side view of a rotating end cap.

FIG. 7 is a side view of a rotating cap top showing apertures therein.

FIG. 8 is another side view of the cap top of FIG. 7.

DETAILED DESCRIPTION OF THE INVENTION

As described herein, multiple embodiments of a screwdriver are provided. In one embodiment, a screwdriver having interchangeable bit bodies with permanently affixed bit heads is provided. In another embodiment, at least one transparent end cap is provided that displays a bit head in an engaged position ready for use. In another alternative, transparent end caps are provided at two ends of the screwdriver. In still another embodiment, two end caps are provided that may nest with each other. In yet another embodiment, a rotatable end cap is provided. It will be recognized that these various embodiments of a precision screwdriver may be utilized independently or in combination with one or more of the other embodiments. For ease of description, a screwdriver utilizing each of these embodiments in one combination is shown herein with regard to the figures presented. However, this combination is shown for illustrative purposes and a user's preferred embodiment may comprise only one or some subset of a combination of the embodiments and concepts described herein.

FIG. 1 shows an exploded side view of one embodiment of a screwdriver **100** having a main body **101** that holds at

3

least two bit bodies **102** and **103**, each having at least two bit heads **102A**, **102B**, **103A** and **103B**. As shown, the main body **101** may be cylindrically shaped, however, other shapes may be utilized while still advantageously utilizing the various embodiments of the concepts provided herein. It is understood that the main body may hold only one bit body or a main body may hold two or more bit bodies. Bit heads **102A**, **102B**, **103A** and **103B** are permanently affixed to the bit bodies **102** and **103** and can be a large Phillips head **103A**, a large flat head **103B**, a small Phillips head **102A**, and a small flat head **102B**. Other bits however, may be utilized and alternatively the bits may be detachably affixed to the bit bodies. In FIG. 1, large bit heads **103A** and **103B** are shown on opposite ends of one bit body **103**, while small bit heads **102A** and **102B** are shown at opposite ends of another bit body **102**. It is understood that one bit body could alternatively comprise a small head on one end and a large head at the other end, for example.

The bit bodies **102** and **103** shown in FIG. 1 are configured to be quickly and easily removed and inserted into the main body **101** for exposing a desired bit head size and shape for a particular purpose without having to fumble with removing and inserting individual bit heads into apparatus. Permanently affixed bit heads **102A**, **102B**, **103A** and **103B** also alleviate risk of losing individual bit heads **102A**, **102B**, **103A** and **103B**. The main body can comprise internal grooves, channels or other similar mechanisms for holding a bit body **102** and **103** into place so that rotation of the main body **101** also results in rotation of the bit body and the exposed bit head.

FIG. 1 shows rotatable nesting end caps **104** and **106** that provide caps to cover the bit heads while also allowing rotation between the main body **101** and at least a portion of the end caps **104** and **106** during use. Each end cap **104** and **106** may nest with the opposing end cap as shown in described in more detail with regard to FIGS. 3-5. Each end cap **104** and **106** has a rotational cap top **105** and **107** and a cap body **104A** and **106A**. The cap body **104A** or **106A** rotates about the cap top **105** or **107** during use, which allows a user to apply pressure and stabilize the screwdriver **100** at the cap top **105** or **107** respectively while rotating the main body **101**. Further, a first end cap **104** can attach to a second end cap **106** allowing the same rotation of the screwdriver **100** while the cap top **105** remains stationary during use (or vice-versa), as shown in more detail in FIG. 4. While FIG. 1 shows the cap tops **105** and **107** separated from the cap bodies **104A** and **106A** (respectively) in the exploded view of the screwdriver **100**, it is understood that in an exemplary embodiment, the nesting cap top may be permanently rotatably affixed to the cap body. Detents **110** provide a mechanism to allow the end caps **104** and **106** to be snapped in place so that the end caps are prevented from easily falling off the screwdriver. As shown in FIG. 6, each end cap may have a corresponding structure **606** that engages the detent **110** when the cap is placed on the main body of the screwdriver.

FIG. 2 shows an exemplary embodiment of a screwdriver **200** with transparent cap tops **105** and **107** displaying bit heads **102A** and **103A**, thus allowing a user to determine which end of the screwdriver **200** is appropriate for a particular use without having to remove end caps **104** and **106**. The bit heads **102A** and **103A** displayed through the transparent cap tops **105** and **107** are in an engaged position and ready to use. In FIG. 2, exposed bit heads **102A** and **103A** are a small Phillips head **102A** and a large Phillips head **103A**. A user familiar with the bit bodies would know from looking through the transparent cap tops **105** and **107**

4

which end of the screwdriver contained large bit heads **103A** and **103B** and which end housed a bit body having small bit heads **102A** and **102B**, so that if the user needed a small flat head, for example, the user would remove the end cap **104** covering the small Phillips bit head **102A**, remove the bit body from the main body **101**, rotate the bit body and insert it into the main body **101** so that the small flat head would be the exposed bit head. In this manner, a user may more directly and easily locate the bit desirable for a particular use.

FIG. 3 shows an embodiment of a screwdriver **300** with a removable nesting end cap **106** temporarily attached to another nesting end cap **104**. As shown, the end caps are formed so that one end cap may slide over or nest with the other end cap. In an exemplary embodiment shown, the cap bodies are tapered in a manner that allows nesting. In a nesting use, a first end cap is slide over the second end cap until the cap body of the first end cap firmly engages the cap body of the second end cap. Thus an end cap **104** or **106** can be removed and attached to the other end of the screwdriver **300** in a similar fashion to a ball point pen cap attaching to the end of a ball point pen. Further in the example of FIG. 3, the nesting end caps **104** and **106** are each interchangeable and each may be removed from one end of the screwdriver and attached to an opposite end of the screwdriver. As is described below in more detail, the cap tops of the end caps are rotatable. In the example shown in FIG. 3, the cap bodies of two nested end caps engage each other in a manner that still allows for rotation of the screwdriver with respect to the "top" end cap. Thus, as shown in FIG. 3 the main body **101**, cap body **104A** and cap body **106A** may each be relatively unitarily connected and move together with relation to cap top **107** of end cap **106**. In this embodiment, of the nesting caps **104** and **106** engage sufficiently into place when attached to one another so that rotation only occurs at the point between the fully exposed cap top **107** and cap body **106A**. As shown in FIG. 3, the main body **101** holds a bit body with permanently affixed bit head **103A** now exposed and ready for use while conveniently holding the end cap **106** in a nested arrangement. A large Phillips head is shown in FIG. 3, however the bit body can be removed from the main body **101** and inserted in an opposite direction exposing an alternate bit head, i.e. a large flat bit head, while the end cap **106** remains secured in the nested position.

FIG. 4 shows a screwdriver in use **400**, where a hand **401** holds and rotates the screwdriver. For illustrative purposes FIG. 4 shows the rotation of a screwdriver while end caps are nested, however, as will be recognized the rotational movement described below is also provided when end caps are not nested and the rotational concepts described herein may be utilized independently of the nesting of two end caps. As shown, the cap top **107** is configured to allow rotation of the screwdriver **400** while the cap top **107** is stationary. Rotation occurs at a connection of the cap top **107** and cap body **106A** (a similar rotation point between cap top **105** and cap body **104A** is provided for use when the end caps are nested in an opposite manner or when the caps are not nested).

An index finger **402** applies pressure to a cap top **107** and stabilizes the screwdriver while a thumb **403** or thumb and middle finger (not shown) rotates the screwdriver at the main body **101**. It is understood that a user can alternatively apply pressure to the cap top **107** with a palm of a second hand while rotating the main body with the thumb **403** and index finger **402** of the first hand **401**, or any other similar technique that is most comfortable and effective for the user. The end cap **106** in FIG. 4 was removed from its previous

5

position over the bit body **103** and bit head **103A** and attached to the opposite end of the screwdriver in engagement with the cap body **104A**. While attaching the end cap **106** to another end cap **104** is an anticipated technique, it is understood that a removed end cap **106** need not be attached to the screwdriver for it to function as intended while providing rotation. The removed end cap **106** can simply be placed to the side and the rotational aspect of end cap **104** may be utilized while the screwdriver **400** is in use.

FIG. **5** shows a cross section of a screwdriver **500** as shown in FIG. **3**, with a first nesting cap **106** attached to a second nesting cap **104**. Bit bodies **102** and **103** are shown housed in a main body **101**. The bit bodies **102** and **103** have permanently affixed exposed bit heads **102A** and **103A**, as well as permanently affixed bit heads on opposite ends of the bit bodies **102** and **103** contained within the main body **101**. While only two bit bodies **102** and **103** are shown, it is understood that the main body **101** could be configured to hold more or less than two bit bodies. The ends of the main body **101** are configured to securely engage bit bodies **102** and **103** as shown. It is desirable that the bit bodies be engaged sufficiently tight such that rotation of the main body **101** also rotates the bit bodies **102** and **103** yet still allowing for the bit bodies to be slide out to switch which bit is being utilized. In one embodiment, the bit bodies and the main body may be shaped to securely engage each other, such as for example through the use of hexagon shaped bit bodies and a hexagon shaped cavity within the main body.

FIG. **6** shows a cross section **600** of a screwdriver end cap **106** having a cap top **107** rotatably connected to a cap body **106A**. The rotatable connection of cap top **107** may further be understood with regard to FIGS. **7-8** which illustrate a side view of a cap top.

The cap top **107** comprises apertures **603** in a connecting portion **602** that allows for compression such that the cap top may be inserted into the cap body **106A**. The cap top **107** further comprises extension members **604** which extend outward from the connecting portion **602**. The cap body **106A** comprises a top edge **605** configured to engage to the extension members **604** of cap top **107**. Thus, the connecting portion **602** may be compressed during insertion into the cap body **106A**. Then when the extension members have been slide past the top edge, the connecting portion may then spring or snap back so that the cap top **107** will now be held in a manner such that the cap top will be engaged with the cap body while still allowing rotation between the cap body and cap top. In this manner the cap top is held in place while still being allowed to freely rotate.

FIG. **7** shows a side view of a cap top **107** illustrating the apertures **603** (on opposing sides of the cap), the connecting portions **602**, and the extension members **604**. FIG. **8** is a side view of the cap top **107** rotated ninety degrees with respect to the cross section of FIG. **7** illustrating the connecting portion **602** and the extension members **604**. Moreover, it will be recognized that the concepts described herein with regard to a cap top that freely rotates with respect to the cap body may be achieved through any number of structural arrangements and that the structures shown herein are merely exemplary. Thus, with respect to the rotating cap body it is merely desirable that rotation between the cap top and cap body be provided while the particular mechanism utilized to achieve such rotation is merely a design choice. It is noted that in nested arrangements such as shown in FIGS. **3** and **4**, the outer cap top (such as cap top **107** of FIGS. **3** and **4**) may still freely rotate with respect to its corresponding cap body **106A**. Because of the tapered profile of the caps **104** and **106**, when in the nested arrange-

6

ment the outer cap body (cap body **106A** in the example shown) securely engages the inner cap body (cap body **104A**). Advantageously, when nested the outer cap to **107** is allowed to rotate with respect to the inner cap body **104A**. Though achieved through the use of tapered bodies, the concept of utilizing nesting caps with rotation between the outer cap top and the inner cap may be achieved through other structures.

The various screwdriver components described above may be formed of a wide variety of material types, and the concepts described herein may be utilized independent of the materials utilized. In one embodiment, the main body **101** may have an outer exterior of a central region of the main body (such as region **405** shown in FIG. **4**) that is utilized as a gripping region made of relatively soft high grip material. For example, the material may be a rubber, elastomeric material, or the like. The bit heads may be formed of a metal and the other components may be injection molded plastic. As mentioned, however, other materials may also be utilized.

Further modifications and alternative embodiments of this invention will be apparent to those skilled in the art in view of this description. It will be recognized, therefore, that the present invention is not limited by these example arrangements. Accordingly, this description is to be construed as illustrative only and is for the purpose of teaching those skilled in the art the manner of carrying out the invention. It is to be understood that the forms of the invention herein shown and described are to be taken as the presently preferred embodiments. Various changes may be made in the implementations and architectures. For example, equivalent elements may be substituted for those illustrated and described herein, and certain features of the invention may be utilized independently of the use of other features, all as would be apparent to one skilled in the art after having the benefit of this description of the invention.

What is claimed is:

1. A screwdriver, comprising:

- a main body configured to hold a bit body in place;
- a first end of the screwdriver having a first end cap, the first end cap having a first end cap first portion and a first end cap second portion;
- a second end of the screwdriver being located at an end opposite of the first end, the second end having a second end cap, the second end cap having a second end cap first portion and a second end cap second portion; and

wherein each of the end caps is configured to allow rotation between the first portion of the end cap and the second portion of the end cap wherein one of the first portion of the first end cap and the first portion of the second end cap extend beyond an end of the bit body when the bit body is held in place by the main body.

2. The screwdriver of claim 1, wherein the bit body is removable from the main body.

3. The screwdriver of claim 2, wherein the bit body has a first bit head and a second bit head.

4. The screwdriver of claim 3, wherein at least one of the first and second end caps comprises:

- a cap top that forms the first portion; and
- a cap body that forms the second portion, wherein rotation between the cap top and cap body is provided.

5. The screwdriver of claim 1, wherein at least some of at least one of the first and second end caps is transparent such that a bit head in an engaged ready to use position is displayed.

7

6. The screwdriver of claim 1, wherein the first and second end caps may nest.

7. The screwdriver of claim 1, wherein the main body includes at least one region formed of a gripping material.

8. A screwdriver, comprising:
a first removable nesting end cap; and
a second removable nesting end cap, the first and second removable nesting end caps configured to nest with each other;

wherein when the first removable nesting end cap and the second removable nesting end cap are nested, a portion of the outer of the two end caps rotates freely with respect to the inner of the two end caps.

9. The screwdriver of claim 8, wherein both of the nesting caps comprises a nesting cap body and a nesting cap top.

10. The screwdriver of claim 9, wherein at least one of the nesting end caps allows rotation with respect to the main body while the one nesting end cap is nested with the other nesting cap.

11. The screwdriver of claim 10, wherein at least some of at least one of the nesting end caps is transparent.

12. The screwdriver of claim 11, wherein the nesting cap top of both the first and second nesting caps is transparent.

13. A screwdriver, comprising:
a main body configured to hold at least two bit heads, a first bit head at a first end of the screwdriver and second bit head at a second end of the screwdriver;
a first end cap covering the first bit head; and
a second end cap covering the second bit head,
wherein the first and second end caps are each configured to allow rotation between a first portion of the end cap and a second portion of the end cap.

14. The screwdriver of claim 13, wherein first and second end caps are nesting end caps.

15. The screwdriver of claim 14, wherein the first portion of the end caps is a cap body, the cap body of the first end cap and the cap body of the second end cap each being configured to engage each other when in a nested position.

16. The screwdriver of claim 15, wherein at least one of the first and second end caps allows rotation even while attached in a nesting manner to the other end cap.

17. The screwdriver of claim 13, wherein at least a portion of at least one of the first and second end caps has is transparent.

18. The screwdriver of claim 17, wherein the second portion of first end cap is a transparent first cap top and the second portion of the second end cap is a transparent second cap top.

19. The screwdriver of claim 18, wherein the main body includes at least one region formed of a gripping material.

20. A screwdriver, comprising:
a main body configured to hold a first bit head and a second bit head, the first and second bit heads being in an engaged position ready for use, the first bit head being at a first end of the screwdriver and the second bit head being at a second end of the screwdriver;
a first transparent cap for exposing at least a portion of the first bit head while covering the first bit head while the first bit head is in the engaged position ready for use; and
a second transparent cap for exposing at least a portion of the second bit head covering the second bit head while the second bit head is in the engaged position ready for use,

wherein the first transparent cap has a first transparent cap top and the second transparent cap has a second transparent cap top, and

8

wherein the first transparent cap further comprises a non-transparent first cap body and the second transparent cap further comprises a non-transparent second cap body.

21. A screwdriver, comprising:
a main body configured to hold a first bit head and a second bit head, the first and second bit heads being in an engaged position ready for use, the first bit head being at a first end of the screwdriver and the second bit head being at a second end of the screwdriver;

a first transparent cap for exposing at least a portion of the first bit head while covering the first bit head while the first bit head is in the engaged position ready for use; and

a second transparent cap for exposing at least a portion of the second bit head covering the second bit head while the second bit head is in the engaged position ready for use,

wherein the first transparent cap has a first transparent cap top and the second transparent cap has a second transparent cap top, and

wherein the first transparent cap top is rotatable with respect to another portion of the first transparent cap and the second transparent cap top is rotatable with respect to another portion of the second transparent cap.

22. A screwdriver, comprising:
a main body configured to hold a first bit head and a second bit head, the first and second bit heads being in an engaged position ready for use, the first bit head being at a first end of the screwdriver and the second bit head being at a second end of the screwdriver;

a first transparent cap for exposing at least a portion of the first bit head while covering the first bit head while the first bit head is in the engaged position ready for use; and

a second transparent cap for exposing at least a portion of the second bit head covering the second bit head while the second bit head is in the engaged position ready for use,

wherein at least a portion of at least one of the first transparent cap and the second transparent cap is non-transparent.

23. A screwdriver, comprising:
a main body configured to hold a first bit head and a second bit head, the first and second bit heads being in an engaged position ready for use, the first bit head being at a first end of the screwdriver and the second bit head being at a second end of the screwdriver;

a first transparent cap for exposing at least a portion of the first bit head while covering the first bit head while the first bit head is in the engaged position ready for use; and

a second transparent cap for exposing at least a portion of the second bit head covering the second bit head while the second bit head is in the engaged position ready for use,

wherein the first and second transparent caps may nest.

24. A screwdriver, comprising:
a main body configured to hold a first bit head and a second bit head, the first and second bit heads being in an engaged position ready for use, the first bit head being at a first end of the screwdriver and the second bit head being at a second end of the screwdriver;

a first transparent cap for exposing at least a portion of the first bit head while covering the first bit head while the first bit head is in the engaged position ready for use;

9

a second transparent cap for exposing at least a portion of the second bit head covering the second bit head while the second bit head is in the engaged position ready for use; and

a first bit body and a second bit body, the first bit head 5 being attached to the first bit body and the second bit head being attached to the second bit body.

25. The screwdriver of claim **24**, further comprising a third bit head attached to the first bit body and a fourth bit head attached to the second bit body. 10

26. A screwdriver, comprising:

a main body configured to hold a first bit head and a second bit head, the first and second bit heads being in an engaged position ready for use, the first bit head

10

being at a first end of the screwdriver and the second bit head being at a second end of the screwdriver;

a first transparent cap for exposing at least a portion of the first bit head while covering the first bit head while the first bit head is in the engaged position ready for use; and

a second transparent cap for exposing at least a portion of the second bit head covering the second bit head while the second bit head is in the engaged position ready for use,

wherein the main body includes at least one region formed of a gripping material.

* * * * *