



US007254118B1

(12) **United States Patent**
Terasawa et al.

(10) **Patent No.:** **US 7,254,118 B1**
(45) **Date of Patent:** **Aug. 7, 2007**

(54) **METHOD AND APPARATUS IN A CDMA COMMUNICATION SYSTEM**

6,363,060 B1 3/2002 Sarkar
6,477,183 B1 * 11/2002 Yamamoto 370/508

(75) Inventors: **Daisuke Terasawa**, San Diego, CA (US); **Francesco Grilli**, Irvine, CA (US); **Serge Willenegger**, Onnens (CH)

FOREIGN PATENT DOCUMENTS
EP 0845877 6/1998
WO WO 98/44669 10/1998
WO 9857450 12/1998

(73) Assignee: **QUALCOMM Incorporated**, San Diego, CA (US)

OTHER PUBLICATIONS

(*) Notice: Subject to any disclaimer, the term of this patent is extended or adjusted under 35 U.S.C. 154(b) by 0 days.

European Search Report, Mailed Nov. 28, 2006, Application No. 06022087.8-2411, pp. 1-3.
3GPP, "Universal Mobile Telecommunications System (UMTS)", ETIS Standards, European Telecommunications Standards Institute, Sophia-Antipo, FR, vol. 3-R2, No. V320, Mar. 2000, pp. 1-507, XP 014008794.

(21) Appl. No.: **09/576,063**

* cited by examiner

(22) Filed: **May 22, 2000**

(51) **Int. Cl.**
H04Q 7/00 (2006.01)

Primary Examiner—John Feild
Assistant Examiner—Inder Pal Mehra
(74) *Attorney, Agent, or Firm*—S. Hossain Beladi; Thien Nguyen; Thomas Rouse

(52) **U.S. Cl.** **370/328**; 342/350; 342/441; 342/503; 342/519; 455/502; 455/524

(58) **Field of Classification Search** 370/320, 370/328, 331, 335, 342, 350, 441, 508–512, 370/514, 518–520, 442, 503; 455/436, 442, 455/502, 524, 525, 517, 522
See application file for complete search history.

(57) **ABSTRACT**

A novel and improved method and apparatus, in a WCDMA communication system (100), for informing a mobile station (101) of a downlink data frame time offset by determining the downlink data frame time offset, and transmitting the downlink data frame time offset via an Active Set Update message transmitted from a cell (102 or 103) to mobile station (101). Once an Active Set Update message is received, the data frame time offset information is provided to a timing block (201) which may determine data frame boundary of each downlink signal. Timing block (201) may then adjust the PN sequence timing corresponding to the downlink signal associated with the data frame time offset such that corresponding data symbols in each data frame are correctly soft combined in a combiner (210).

(56) **References Cited**

U.S. PATENT DOCUMENTS

5,101,501	A	3/1992	Gilhousen et al.	455/442
5,201,066	A *	4/1993	Kim	455/411
5,640,414	A	6/1997	Blakeney, II et al.	375/130
5,828,659	A *	10/1998	Teder et al.	370/328
5,893,036	A *	4/1999	Trandai et al.	455/522
6,005,852	A *	12/1999	Kokko et al.	370/329
6,011,974	A	1/2000	Cedervall et al.	455/456.4
6,018,667	A	1/2000	Ghosh et al.	455/502
6,061,337	A	5/2000	Light et al.	370/331
6,239,719	B1 *	5/2001	Hopkins	340/7.51

19 Claims, 2 Drawing Sheets

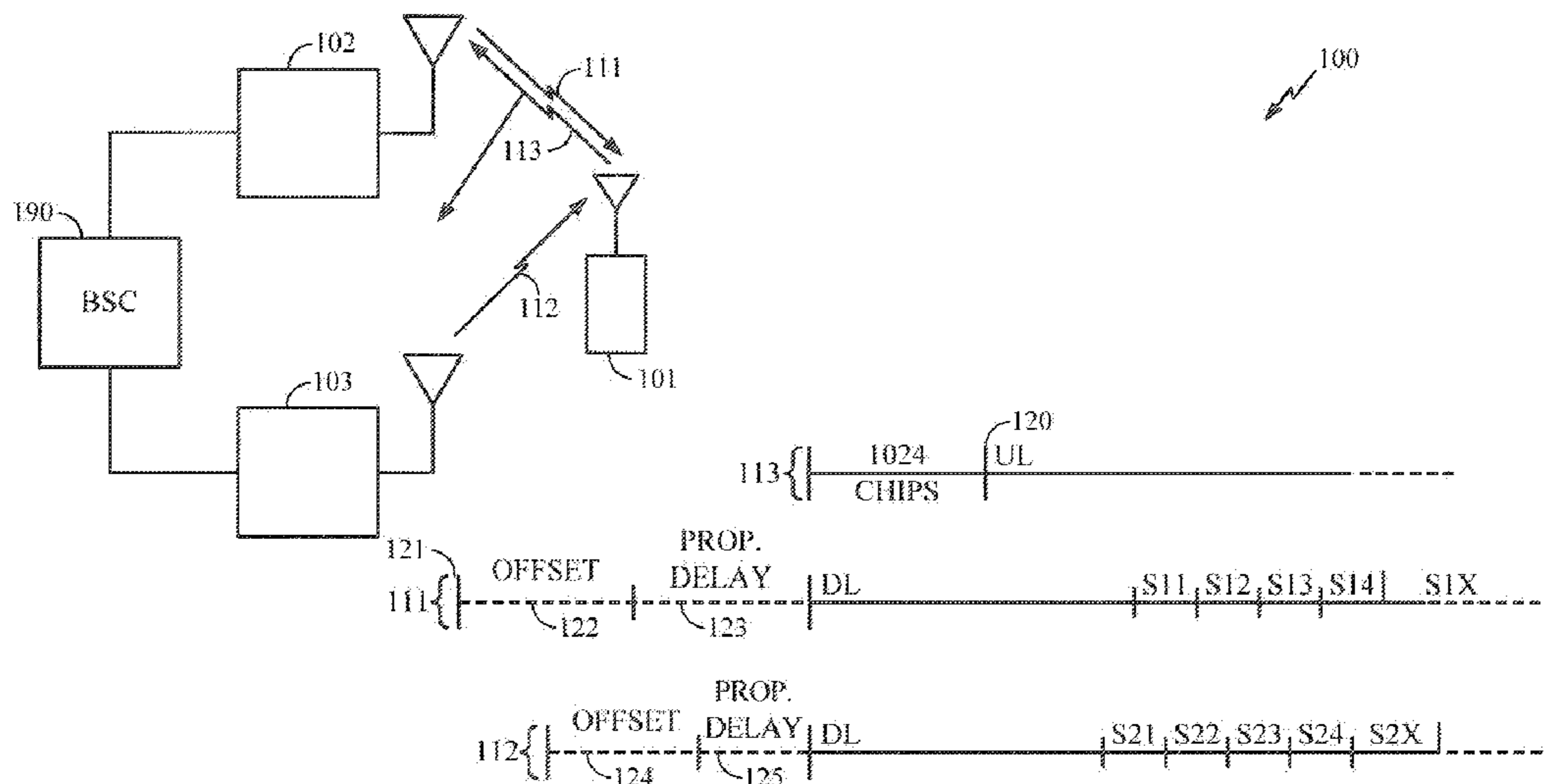

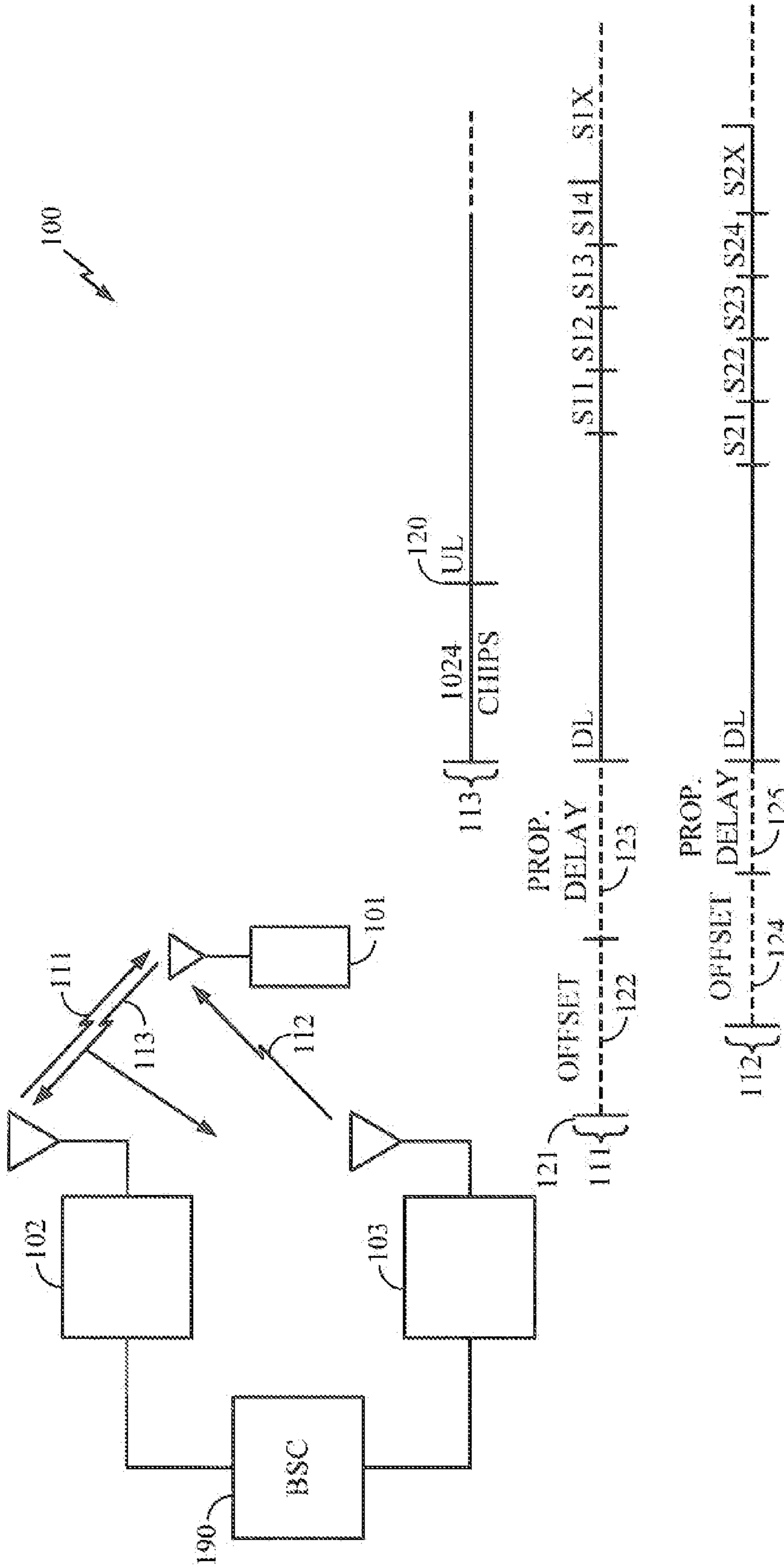

FIG. 1

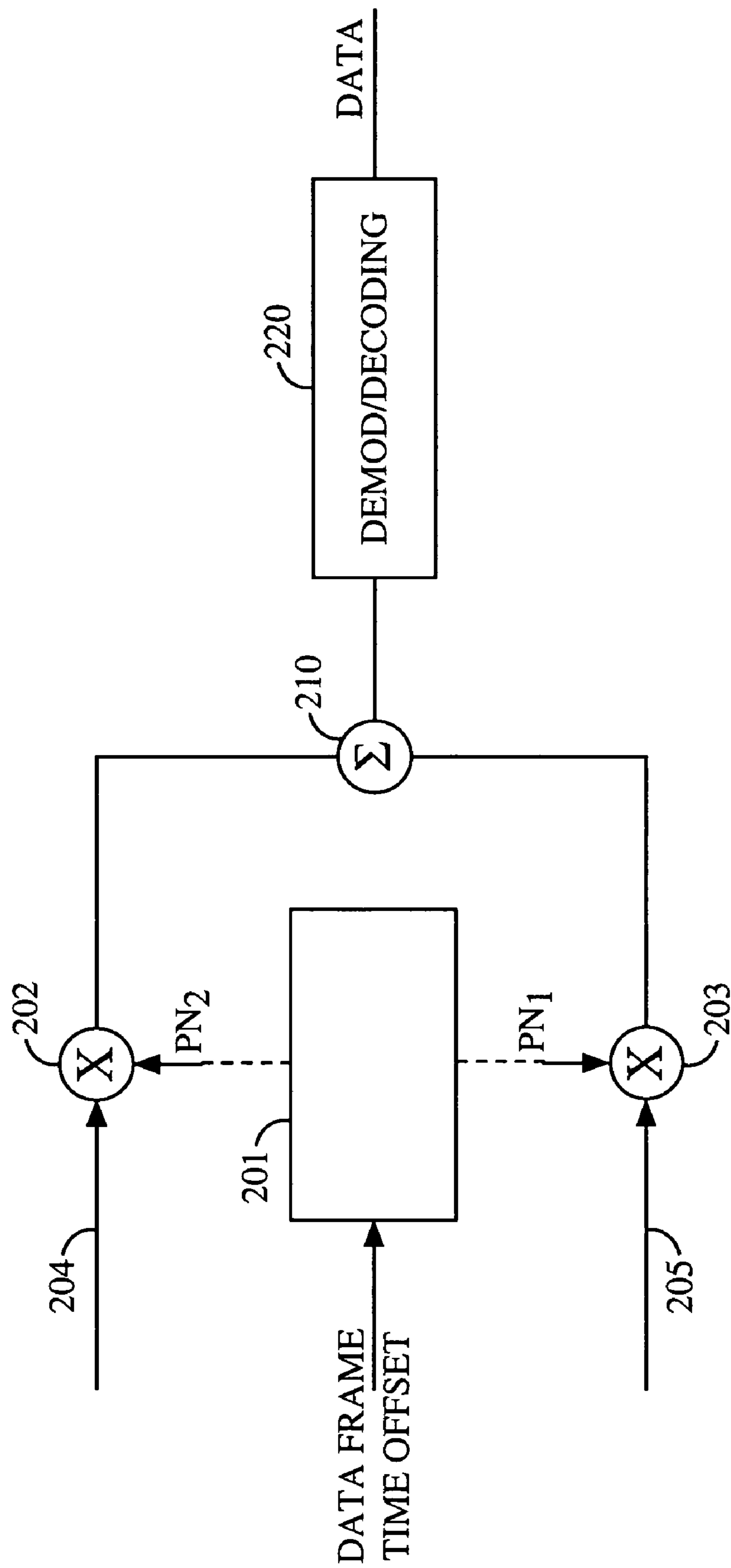

FIG. 2

METHOD AND APPARATUS IN A CDMA COMMUNICATION SYSTEM

BACKGROUND OF THE INVENTION

I. Field of the Invention

The present invention relates to communication systems. More particularly, the present invention relates to a novel and improved method and apparatus for soft handoff operations in a communication system operating according to Wideband Code Division Multiple Access (WCDMA) principles.

II. Description of the Related Art

The 3rd Generation Partnership Project (3GPP) recently issued a version of its technical specifications commonly referred to as the WCDMA standard. The publication is well known in the art, and describes the operational standard in a WCDMA system. The standard is still evolving at the time of this application for a patent. A copy of the standard may be obtained by contacting 3GPP, 650 Route des Lucioles—Sophia Antipolis, Valbonne—France, or by accessing the World Wide Web at the internet address www.3gpp.org. The latest version of the standard at the time of this application for a patent, and all previously revised publications of the same, are incorporated by reference herein.

Soft handoff operation is well known. A patent issued to Blakeney, II et al, with U.S. Pat. No. 5,640,414, and a patent issued to Gilhousen et al, with U.S. Pat. No. 5,101,501, both assigned to the assignee of the present application for a patent, both incorporated by reference herein, provide methods and systems for providing soft handoff in communications in a CDMA communication system. Generally, a mobile station in soft handoff operation receives and combines multiple signals transmitted from different cells in order to improve the overall decoding and demodulation of the information. The signals transmitted from the cells involved in the soft handoff operation carry the same information. The mobile station after decoding and demodulating the signals combines the data metrics in a soft summing operation to add the data energy. As a result, the information data is received with less error.

In CDMA systems, including WCDMA systems, each cell may have a unique pseudo random noise (PN) sequence. Downlink signals transmitted from each cell are multiplied with the PN sequence as a part of the signal spreading function. The downlink signal received by a mobile station is subjected to a de-spreading operation in accordance with the PN sequence used by the transmitter. The result of the de-spreading operations at the data symbol level is combined with the result of de-spreading operation of other signals transmitted by other cells involved in the soft handoff operation. Signals originating from the same cell but arriving at the mobile with different delays due to multipath can be combined in the same manner. A commonly known Rake receiver may be used for the combining operation.

When performing the soft-combining operation, it is important that the mobile combines the matching symbols received from the cells involved in soft handoff. For example, the first symbol of a particular frame from a first cell needs to be combined with the first symbol of the matching frame from a second cell, and so on. The mobile station needs to know the frame timing of the data signals from each cell. Due to factors including the possibility of cell timing being asynchronous with each other, the possible timing offset between the PN spreading code frame timing and the data frame timing, and the uncertainties in the propagation delay, the mobile cannot necessarily rely on the

arrival timing of the symbols from each cell to determine which symbols should be combined.

Therefore, there is a need for a method and apparatus for ensuring that a mobile station is aware of the data frame time offset of each downlink signal transmitted by each cell involved in a soft handoff operation at the mobile station.

SUMMARY OF THE INVENTION

The present invention is directed to a novel and improved method and apparatus, in a communication system, for informing a mobile station of a downlink data frame time offset by determining the downlink data frame time offset, and transmitting the downlink data frame time offset from a cell to the mobile station. The method and the accompanying apparatus further advantageously include receiving time offset information measured by the mobile station. Determining the downlink data frame time offset is based on the time offset measured by the mobile station. The mobile can determine the timing of the frame boundaries based on the offset information in the message. The timing offset measurement report sent by the mobile and received by the network is used by a new cell to come up with the frame offset. Once it comes up with the offset, it signals the chosen offset to the mobile. The method and the accompanying apparatus further advantageously include receiving the time offset via a measurement report message. The time offset is measured by the mobile station. The measurement report message is transmitted by the mobile station to at least a base station controller controlling the cell. Once the mobile station receives an Active Set Update message, the data frame time offset information is provided to a timing block. Upon knowing data frame time offsets associated with each downlink signal, the timing block may determine data frame boundaries of each downlink signal. The timing block may then adjust the PN sequence timing corresponding to the downlink signal associated with the data frame time offset such that corresponding data symbols in each data frame are correctly soft combined in a combiner. The result of the soft combining operation is subjected advantageously to a demodulator/decoder for retrieving the information.

BRIEF DESCRIPTION OF THE DRAWINGS

The features, objects, and advantages of the present invention will become more apparent from the detailed description set forth below when taken in conjunction with the drawings in which like reference characters identify correspondingly throughout and wherein:

FIG. 1 is a block diagram of downlink signal timing with respect to each other and an uplink signal communicated between a mobile station and two cells in a soft handoff condition in a communication system; and

FIG. 2 is a block diagram of a portion of a receiver in a mobile station for determining time boundaries of data symbols based on data frame time offsets communicated to the mobile station via an Active Set Update message in accordance with various embodiments of the invention.

DETAILED DESCRIPTION OF THE PREFERRED EMBODIMENTS

A method and apparatus has been described in a patent application titled: "Method and Apparatus for Fast WCDMA Acquisition", with Ser. No. 09/345,283, now U.S. Pat. No. 6,363,060, commonly assigned to the assignee of the present application, and incorporated by reference herein. U.S. Pat.

No. 6,363,060 application provides a description for a method and apparatus for synchronization of a mobile station with a cell. Based on the synchronization data, the mobile station is able to determine a data frame time offset referenced to the mobile station uplink data frame timing. The uplink signal according to the standard is transmitted within a fixed time offset after reception of a downlink signal from a cell. The uplink signal time offset may be fixed to 1024 chips. The mobile station, after determining the observed time difference, transmits the information to the cell via a message commonly known as an SFN—SFN message. The 3G TS 25.331 v3.2.0 (2000-03) document, section 10.3.7.90, provides the description and the requirements for the observed time difference message. The observed time difference information is included in a cell measurement results message 10.3.7.3. The mobile station may periodically report to the cell. The mobile station measures and reports the time difference in a unit of a chip time.

The cell in connection with its base station controller sets data frame time offset for a downlink physical channel intended for the mobile station that reported the SFN number on a measurement report message. The 3G TS 25.221 v3.2.0 (2000-03) document, section 7 and its subsections, provides the description for the timing difference between different physical channels. For example, the primary common control physical channel is used as a timing difference for all physical channels, directly for the downlink and indirectly for the uplink. The dedicated physical channels intended for communication of data and voice information are set in a data frame time offset from common control and pilot physical channels. The data frame time offset is set in a multiple of 256 chips from the common control and pilot physical channels.

The mobile station transmits a report message based on the measurement of the signals, such as the sync and the common pilot signals, for each cell within a range. Each report message contains the time delay difference measurement between the uplink timing and the downlink PN sequence frame timing from each cell (i.e. common and pilot channel frame timing) and an SFN number. The propagation distance from each base station to the mobile station may be different. The observed time difference measured by the mobile station for each cell may be different. The downlink data frame time offset is set by each cell based on its corresponding measurement report. Each cell may be operating on its own timing synchronously or asynchronously.

Referring to FIG. 1, in an exemplary situation, a mobile station **101** in a soft handoff situation with cells **102** and **103** receives two downlink signals **111** and **112**. A mobile station may be in soft handoff with more than two cells; however, for simplicity of explanation, only a two-way handoff situation is described. Mobile station **101** transmits uplink signal **113** to be received by cells **102** and **103**. Each cell uses the time offset value reported in the measurement report message to set the data frame time offset such that the downlink signal received by the mobile station is approximately 1024 chips away in time from the uplink signal transmitted from the mobile station. For illustrative purposes, for example, uplink signal **113** is transmitted at time **120**. Cell **102** communicates to mobile station **101** via downlink **111**. If the common control channel time reference of cell **102** is at time **121**, cell **102** sets a data frame time offset **122** from time **121** such that after taking into account the propagation delay **123**, downlink signal **111** arrives approximately 1024 chips time away from uplink transmit time **120**.

Mobile station **101** transmits a measurement report message to the network including a base station controller **190** which informs cell **103** the timing information necessary for determining a time frame offset **124** associated with downlink **112**. Cell **103** sets data frame time offset **124** such that after including a propagation delay **125** associated with propagation delay of downlink signal **112**, downlink signal **112** arrives at mobile station **101** approximately 1024 chips time away from uplink transmit time **120**. The downlink signals **111** and **112**, thus, arrive within approximately 1024 chips time of the uplink signal **113** at mobile station **101**. When mobile station **101** is in soft handoff with base stations **102** and **103** via downlink signals **111** and **112**, respectively, the soft combining operation may be performed.

In one embodiment of the invention, the data frame time offset **122** and **124** are in increments of 256 chips time. The beginning of the PN sequence is set to coincide at the beginning of the cell common control and pilot channel time frame. Each downlink physical channel is spread with a PN sequence. As such, each downlink signal is at least 256 chips in time offset from the other. Downlink signals to different mobiles can have the same timing offset.

In one embodiment of the invention, when the mobile station **101** is performing soft combining at the data symbol level, the data symbols extracted from each downlink signal may be identified in terms of location in the data frame for an effective soft combining operation with another data symbol in the same location of another data frame. Each data symbol may be between 4 and 512 chips in duration. The data frame time offset is in increments of 256 chips. Data symbols transmitted via the downlink signals then need to be identified at the mobile station for the soft combining operation. Data frame time offset **122** is set by cell **102** and data frame time offset **124** is set by cell **103**, depending on the measurements reported by the mobile station. The data symbols **S1X** received via downlink signal **111** needs to be combined with data symbols **S2X** received via downlink signal **112**. If mobile station **101** is not aware of the data symbol boundaries, data symbols of different downlink signals may not correspondingly be combined. Since the cells attempt to adjust the transmit timing of the data channel so that signals from different cells arrive at the mobile station at roughly the same time, one thing the mobile may do is combine symbols that are “closest” together in time. However, the possibility of propagation time relationships changing between the time of measurement report and the start of the soft combining operation leaves ambiguities for the mobile station for soft combining operation.

According to various embodiments of the invention, in a communication system **100**, a method and accompanying apparatus provide for informing mobile station **101** of a downlink data frame time offset by determining the downlink data frame time offset, and transmitting the downlink data frame time offset via an Active Set Update message transmitted from a cell to mobile station **101**. The method and the accompanying apparatus further include receiving time offset information measured by mobile station **101**. Determining the downlink data frame time offset is then based on the time offset measured by mobile station **101**. The method and the accompanying apparatus further include receiving the time offset via a measurement report message. The time offset is measured by mobile station **101**. The measurement report message is transmitted by mobile station **101** to at least base station controller **190**.

In one embodiment of the invention, mobile station **101** may adjust its internal timing after identifying the boundaries of data symbols for the combining operation. An

effective combining operation is possible since according to an embodiment of the invention, mobile station **101** is aware of the data frame time offset used by the cells. Mobile station **101** is able to determine data symbol boundaries since the downlink signal is spread by a PN sequence whose beginning coincides with the beginning of the common control channel and the pilot channel. Mobile station **101** while in communication with a cell knows the timing boundary of the common control channel and the pilot channel, as deduced from timing associated with the beginning of the PN sequence through an ongoing synchronization process. The mobile station **101** measures the PN sequence timing. Knowing the relationship between the PN sequence timing and the control/pilot channel frame timing allows mobile station **101** to deduce the frame timing. Mobile station **101** de-spreads the downlink signal by removing the PN sequence from the signal. The boundary of the first data symbol is in time offset in increments of the data frame time offset from the beginning of the PN sequence. Therefore, once the mobile station knows the data frame time offset, it can determine the location of the data frame boundary with respect to the PN sequence timing. Since data symbols are fixed in duration, boundaries of subsequent data symbols after the first data symbol can easily be determined. The data symbol combining operation takes place after the despreading operation. The mobile station can adjust the data symbol boundaries of a Rake receiver finger to coincide to the data symbol boundaries outputting from other fingers assigned to other downlink signals.

The 3G TS 25.331 v3.2.0 (2000-03) document, section 8.3.4, provides a procedure for generating Active Set Update message in a soft handover operation, otherwise known as a soft handoff operation. The purpose of the Active Set Update is to update the active set of the connections between the mobile station and various cells involved in the soft handoff operation. The base station controller (BSC) **190** initiates the procedure to modify the downlink connections. For all the signaling activities including—ACTIVE SET UPDATE, MEASUREMENT REPORT, etc, the mobile station is in communication with the BSC **190** (or radio network controller (RNC) in WCDMA terminology). Each cell includes a transceiver that does some physical layer processing (such as coding/decoding, interleaving/deinterleaving, and spreading/despreading.) The 3G TS 25.331 v3.2.0 (2000-03) document, section 8.5.7, provides the description for generic actions for receipt of the information. A new Section 8.5.7.6.13 may be added that may describe according to various embodiments of the invention what mobile station **101** is expected to do when it receives data frame time offset. Pursuant to the section 10.3.6.15, Downlink DPCH information for radio link may be modified to include the data frame time offset associated with the downlink. The data frame time offset may be communicated in increments of a chip time or 256 chip times.

Referring to FIG. 2, a simplified block diagram of a receiver in a mobile station is shown for soft combining operation according to various embodiments of the invention. Downlink signals **204** and **205**, after proper down conversion and signal processing (not shown), are input to de-spreaders **202** and **203**. Each downlink signal may be associated with a cell. Once an Active Set Update message is received, the data frame time offset information is provided to a timing block **201**. Upon knowing the data frame time offset associated with each downlink signal, timing block **201** may determine the data frame boundaries of each downlink signal. Timing block **201** may then adjust the PN sequence timing corresponding to the downlink signal asso-

ciated with the data frame time offset such that corresponding data symbols in each data frame are correctly soft combined in a combiner **210**. The result of the soft combined operation is provided to the demodulator/decoder **220** for retrieving the information.

Accordingly, a soft combining operation at the data symbol level is performed with high efficiency and accurate results.

The previous description of the preferred embodiments is provided to enable any person skilled in the art to make or use the present invention. The various modifications to these embodiments will be readily apparent to those skilled in the art, and the generic principles defined herein may be applied to other embodiments without the use of the inventive faculty. Thus, the present invention is not intended to be limited to the embodiments shown herein but is to be accorded the widest scope consistent with the principles and novel features disclosed herein.

We claim:

1. A method for a soft handoff operation in a CDMA communication system, comprising:
 - transmitting data frames from a first base station to a mobile station in accordance with a first downlink data frame time offset, wherein said first downlink data frame time offset is measured from a channel frame timing associated with the first base station;
 - measuring a reception downlink time offset experienced at said mobile station between a first downlink transmission received from said first base station and a second downlink transmission from a second base station;
 - communicating said measured reception downlink time offset from said mobile station to at least one of said first and second base stations;
 - determining a second downlink data frame time offset based on said measured reception downlink time offset, wherein said second downlink data frame time offset is measured from a channel frame timing associated with the second base station, wherein said first and second downlink data frame time offsets are in increments of a predetermined number of chips;
 - communicating said second downlink data frame time offset to said mobile station for said soft handoff operation; and
 - transmitting data frames from said second base station to said mobile station in accordance with said second downlink data frame time offset, wherein data frames transmitted from said first and second base station carry the same data for said soft handoff operation.
2. The method as recited in claim 1 wherein said communicating said second downlink data frame time offset is by way of communicating an Active Set Update message in said CDMA communication system.
3. The method as recited in claim 1 wherein said communicating said measured reception down time offset is by way of communicating a measurement report message from said mobile station.
4. The method as recited in claim 1 further comprising: adjusting timing of a time offset adjuster in said mobile station for adjusting data symbols timing according to said first and second downlink data frame time offsets for identifying corresponding data symbols in transmitted data frames from said first and second base stations for said soft handoff operation.
5. The method as recited in claim 4 wherein said soft handoff operation includes soft combining said corresponding data symbols.

7

6. A method for a soft handoff operation in a CDMA communication system, comprising:

- measuring a reception downlink time offset experienced at a mobile station between a first downlink transmission received from a first base station and a second downlink transmission from a second base station;
- communicating said measured reception downlink time offset from said mobile station to at least one of said first and second base stations;
- receiving data frames from said first base station at said mobile station in accordance with a first downlink data frame time offset, wherein said first downlink data frame time offset is measured from a channel frame timing associated with the first base station;
- receiving a second downlink data frame time offset at said mobile station for said soft handoff operation, wherein said second downlink data frame time offset is determined based on said measured reception downlink time offset, and wherein said second downlink data frame time offset is measured from a channel frame timing associated with the second base station, and wherein said first and second downlink data frame time offsets are in increments of a predetermined number of chips; and
- receiving data frames from said second base station at said mobile station in accordance with said second downlink data frame time offset, wherein data frames received from said first and second base stations carry the same data for said soft handoff operation.

7. The method as recited in claim 6 wherein said receiving said second downlink data frame time offset at said mobile station for said soft handoff operation is by way of receiving an Active Set Update message.

8. The method as recited in claim 6 wherein said communicating said measured reception time offset is by way of communicating a measurement report message from said mobile station.

9. The method as recited in claim 6 further comprising: adjusting timing of a time offset adjuster in said mobile station for adjusting reception data symbols timing according to said first and second downlink data frame time offsets for identifying corresponding data symbols in received data frames from said first and second base stations for said soft combining operation.

10. The method as recited in claim 9 wherein said soft handoff operation includes soft combining said corresponding data symbols.

11. An apparatus for a soft handoff operation in a CDMA communication system, comprising:

- a transmitter and a receiver, wherein said receiver includes a timing block, a de-spreader, a demodulator and a decoder, configured for performing a set of operations including:
 - measuring a reception downlink time offset experienced at said receiver between a first downlink transmission received from a first base station and a second downlink transmission from a second base station;
 - communicating said measured reception downlink time offset from said transmitter to at least one of said first and second base stations;
 - receiving data frames from said first base station at said receiver in accordance with a first downlink data frame time offset, wherein said first downlink data frame time offset is measured from a channel frame timing associated with the first base station;
 - receiving a second downlink data frame time offset at said receiver for said soft handoff operation, wherein said

8

- second downlink data frame time offset is determined based on said measured reception downlink time offset, and wherein said second downlink data frame time offset is measured from a channel frame timing associated with the second base station, and wherein said first and second downlink data frame time offsets are in increments of a predetermined number of chips; and
- receiving data frames from said second base station at said mobile station in accordance with said second downlink data frame time offset, wherein data frames transmitted from said first and second base stations carry the same data for said soft handoff operation.

12. The apparatus as recited in claim 11, wherein said set of operations further comprising:

- adjusting timing of a time offset adjuster in said mobile station for adjusting reception data symbols timing according to said first and second downlink data frame time offsets for identifying corresponding data symbols in received data frames from said first and second base stations for said soft combining operation.

13. The apparatus as recited in claim 12, wherein said set of operations further comprising:

- soft combining said corresponding data symbols.

14. A method for a soft handoff operation in a CDMA communication system, comprising:

- transmitting data frames from a first base station to a mobile station in accordance with a first downlink data frame time offset, wherein said first downlink data frame time offset is measured from a channel frame timing associated with the first base station;
- receiving a measured reception downlink time offset from said mobile station at one of said first and second base stations, wherein said measured reception downlink time offset is the reception time offset experienced at said mobile station between a first downlink transmission from said first base station and a second downlink transmission from a second base station;
- determining a second downlink time offset based on said measured reception downlink time offset, wherein said second downlink data frame time offset is measured from a channel frame timing associated with the second base station wherein said first and second downlink data frame time offsets are in increments of a predetermined number of chips;
- communicating said second downlink data frame time offset to said mobile station for said soft handoff operation; and
- transmitting data frames from said second base station to said mobile station in accordance with said second downlink data frame time offset, wherein data frames transmitted from said first and second base station carry the same data for said soft handoff operation.

15. The method as recited in claim 14 wherein said communicating said second downlink data frame time offset is by way of communicating an Active Set Update message in said CDMA communication system.

16. The method as recited in claim 14 wherein said receiving said measured reception downlink time offset is by way of receiving a measurement report message from said mobile station.

17. An apparatus for a soft handoff operation in a CDMA communication system, comprising:

- a transmitter, a receiver and associated control apparatus configured for performing a set of operations for said handoff operation, wherein said set of operations includes:

9

transmitting data frames from a first base station to a mobile station in accordance with a first downlink data frame time offset, wherein said first downlink data frame time offset is measured from a channel frame timing associated with the first base station; 5
 receiving a measured reception downlink time offset from said mobile station at one of said first and second base stations, wherein said measured reception downlink time offset is the reception time offset experienced at said mobile station between a first 10
 downlink transmission from said first base station and a second downlink transmission from a second base station;
 determining a second downlink time offset based on said measured reception downlink time offset, 15
 wherein said second downlink data frame time offset is measured from a channel frame timing associated with the second base station, wherein said first and second downlink data frame time offsets are in increments of a predetermined number of chips;

10

communicating said second downlink data frame time offset to said mobile station for said soft handoff operation; and

transmitting data frames from said second base station to said mobile station in accordance with said second downlink data frame time offset, wherein data frames transmitted from said first and second base station carry the same data for said soft handoff operation.

18. The apparatus as recited in claim **17** wherein said communicating said second down data frame time offset in said set of operations is by way of communicating an Active Set Update message in said CDMA communication system.

19. The method as recited in claim **17** wherein said receiving said measured reception downlink time offset in said set of operations is by way of receiving a measurement report message from said mobile station.

* * * * *